

EUROPEAN ORGANIZATION FOR NUCLEAR RESEARCH  
European Laboratory for Particle Physics



*Large Hadron Collider Project*

**LHC Project Report 145**

**Helium Recovery in the LHC Cryogenic System  
following Magnet Resistive Transitions**

M.Chorowski, B.Hilbert, L.Serio, L.Tavian, U.Wagner, R. van Weelden

**Abstract**

A resistive transition (quench) of the Large Hadron Collider magnets provokes the expulsion of helium from the magnet cryostats to the helium recovery system. A high-volume, vacuum-insulated recovery line connected to several uninsulated medium-pressure gas storage tanks, forms the main constituents of the system. Besides a dedicated hardware configuration, helium recovery also implies specific procedures that should follow a quench, in order to conserve the discharged helium and possibly make use of its refrigeration capability. The amount of energy transferred after a quench from the magnets to the helium leaving the cold mass has been estimated on the basis of experimental data. Based on these data, the helium thermodynamic state in the recovery system is calculated using a lumped parameter approach. The LHC magnet quenches are classified in a parametric way from their cryogenic consequences and procedures that should follow the quench are proposed.

CERN - LHC-ACR Division

*Presented at CEC-ICMC'1997 - Portland - OR - USA  
July 29 to August 1st, 1997*

Administrative Secretariat  
LHC Division  
CERN  
CH - 1211 Geneva 23  
Switzerland

Geneva, 30 September 1997

## **HELIUM RECOVERY IN THE LHC CRYOGENIC SYSTEM FOLLOWING MAGNET RESISTIVE TRANSITIONS**

M.Chorowski, B.Hilbert, L.Serio, L.Tavian, U.Wagner, R. van Weelden  
LHC Division, CERN  
CH-1211 Geneva 23, Switzerland

### **ABSTRACT**

A resistive transition (quench) of the Large Hadron Collider magnets provokes the expulsion of helium from the magnet cryostats to the helium recovery system. A high-volume, vacuum-insulated recovery line connected to several uninsulated medium-pressure gas storage tanks, forms the main constituents of the system. Besides a dedicated hardware configuration, helium recovery also implies specific procedures that should follow a quench, in order to conserve the discharged helium and possibly make use of its refrigeration capability. The amount of energy transferred after a quench from the magnets to the helium leaving the cold mass has been estimated on the basis of experimental data. Based on these data, the helium thermodynamic state in the recovery system is calculated using a lumped parameter approach. The LHC magnet quenches are classified in a parametric way from their cryogenic consequences and procedures that should follow the quench are proposed.

### **THE LHC HELIUM RECOVERY SYSTEM**

A LHC sector (1/8 of the machine circumference) consists of 46 half-cells in the arc plus a number of special cryomagnets. In the following for this analysis the whole sector will be taken as composed of 54 half-cells. The magnetic energy stored in the magnets that form a LHC half-cell will be released during a quench and may be as high as 23 MJ<sup>1</sup>. This stored magnetic energy is dissipated in the cold mass within a few tenths of a second following a quench. A fraction of this energy is subsequently transferred to the helium, causing a fast pressure increase and heating of the helium bath. Helium is finally discharged to the helium recovery system through a quench relief valve. The purpose of the recovery system is the preservation of the helium inventory and if possible, the recovery of its refrigeration capacity after a quench. As shown conceptually in Figure 1, the system for one LHC sector will consist of the following nodes:

1. 54 half -cells, each containing 850 litres of helium,
2. quench relief valves,
3. a vacuum-insulated line D having a length of about 3400 m and volume of 60 m<sup>3</sup> per sector, connected via quench relief valves (2) to the LHC half-cells (1),
4. an uninsulated vertical line having a length ranging from 42 to 145 m, depending on the sector, connecting line D (3) via valve (4a) with medium-pressure gas storage tanks (5),
5. medium-pressure (2 MPa) gas storage tanks with a volume of 250 m<sup>3</sup> each, forming a quench buffer volume of 2000 m<sup>3</sup>,
6. piping and auxiliaries interconnecting the system with the sector refrigerator.

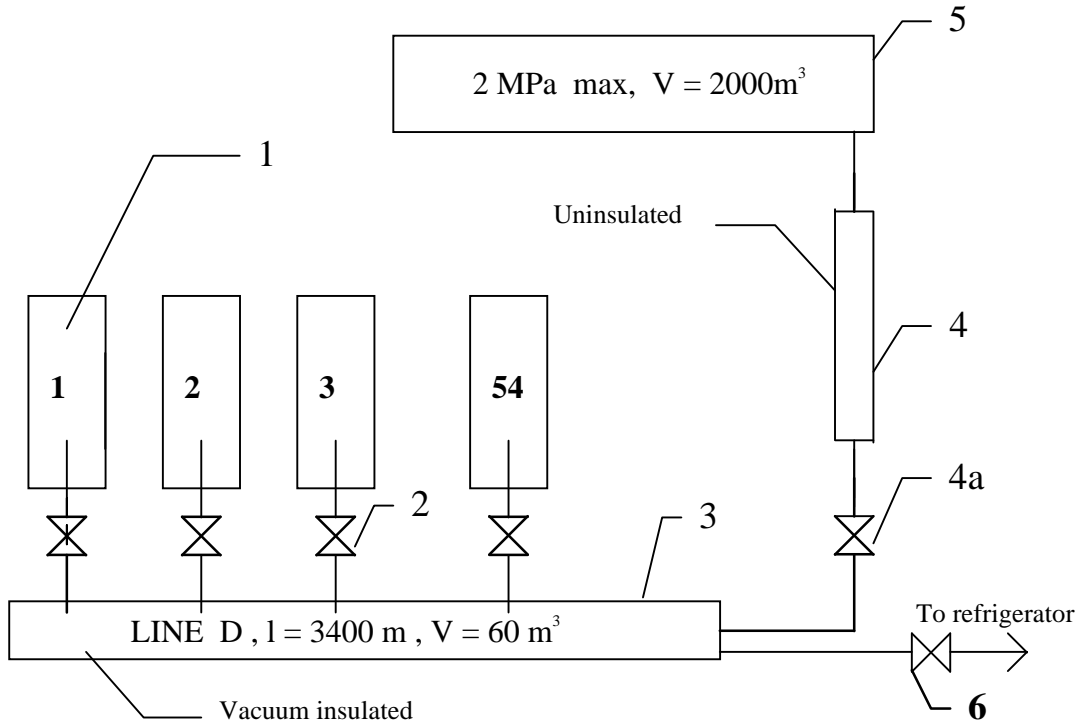

**Figure 1.** Helium recovery system, scheme for one sector; 1 - cryogenic half-cells ; 2 - quench relief valves; 3 - vacuum insulated line D; 4 - uninsulated vertical line; 5 - medium-pressure gas tanks; 6 - auxiliaries

## LUMPED PARAMETER APPROACH TO THE RECOVERY SYSTEM.

We assume that for the purpose of configuring and sizing of the quench recovery system a lumped-parameter approach is adequate. Therefore spatial variations of density, temperature and pressure can be neglected within a system node. For each node of the system, the following energy balance equation can be written:

$$dU = dQ + \sum_i h_i dM_i \quad (1)$$

where  $dU$  is the energy change of a node,  $dQ$  is the heat transferred to a node,  $h_i$  is the enthalpy of the  $i$ -th stream of helium leaving or entering a node,  $dM_i$  is the change of the mass of helium in a node due to the  $i$ -th flow.

### Estimation of Enthalpy and Mass Input Data.

The enthalpy and mass of helium leaving the cold mass after a quench are basic inputs for any further calculations. Experimental data from the prototype magnet string<sup>2</sup>, thermo-hydraulically equivalent to the LHC half-cell, were used to estimate:

- the final distribution of the magnetic energy released after a quench, between cold mass, helium left in the cold mass and helium expelled; this enables the calculation of the average enthalpy  $\bar{h}_{He}$  of the expelled helium,
- the enthalpy,  $h(t)$ , and mass,  $\dot{m}(t)$ , flows of helium leaving the cold mass.

Table 1 gives the final magnetic energy distribution averaged over eleven quenches of the prototype string. The initial conditions of helium temperature, pressure and enthalpy were 1.9 K, 100 kPa and 1864 J/kg respectively. The stored magnetic energy was 15.3 MJ and an estimated amount of helium expelled from the cold mass was 120 kg. The cold mass temperature was measured 30 minutes after each quench. An average helium enthalpy of 33 J/g can be calculated from Eq. (2) on the assumption that the process of heat transfer to helium expelled from the cold mass is isobaric.

$$\bar{h}_{He} = (h_{He-ini}\Delta M_{He-ex} + \Delta E_{He-ex}) / \Delta M_{He-ex} \quad (2)$$

Where  $h_{He-ini}$  is the initial enthalpy of helium,  $\Delta M_{He-ex}$  is the mass of helium expelled from the cold mass and  $\Delta E_{He-ex}$  is the energy transferred to helium expelled from the cold mass.

**Table 1.** Measured energy balance following a full current quench of the prototype string.

	Energy , MJ	Energy , %
Energy transferred to the helium expelled from the cold mass	3.8	25
Energy transferred to the cold mass	10.0	65
Energy transferred to the helium left in the cold mass	1.5	10
Coil magnetic energy	15.3	100

Figures 2 and 3 show helium enthalpy and mass flow measured during discharge from the cold mass. Helium temperature, pressure and pressure drop at the quench relief valve were measured. An average helium enthalpy of 32 J/g can be calculated from Eq. (3), which is in good agreement to the value of 33 J/g obtained from Eq. (2). It confirms the validity of the helium mass flow  $\dot{m}(t)$  estimation.

$$\bar{h}_{He} = \int_0^{\infty} h(t)\dot{m}(t)dt / \int_0^{\infty} \dot{m}(t)dt \quad (3)$$

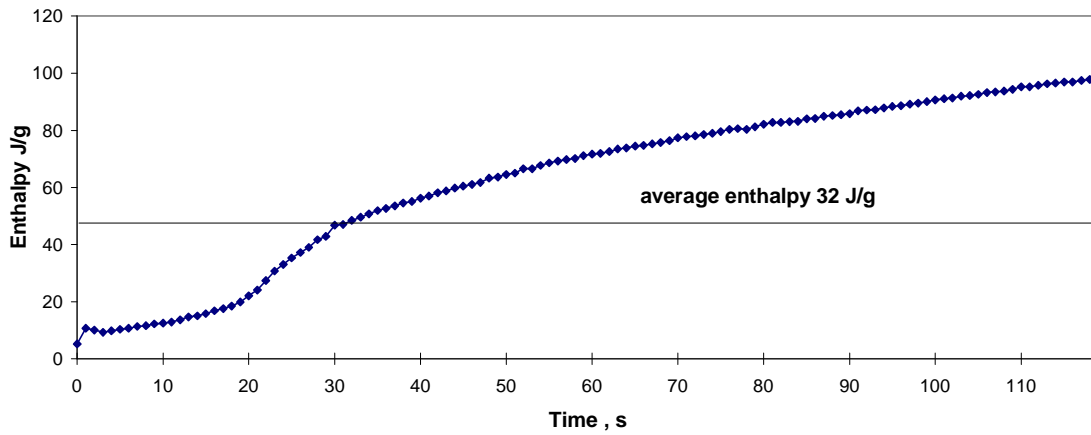

**Figure 2.** Enthalpy of helium leaving the cold mass after a full-current quench of the prototype string (measured).

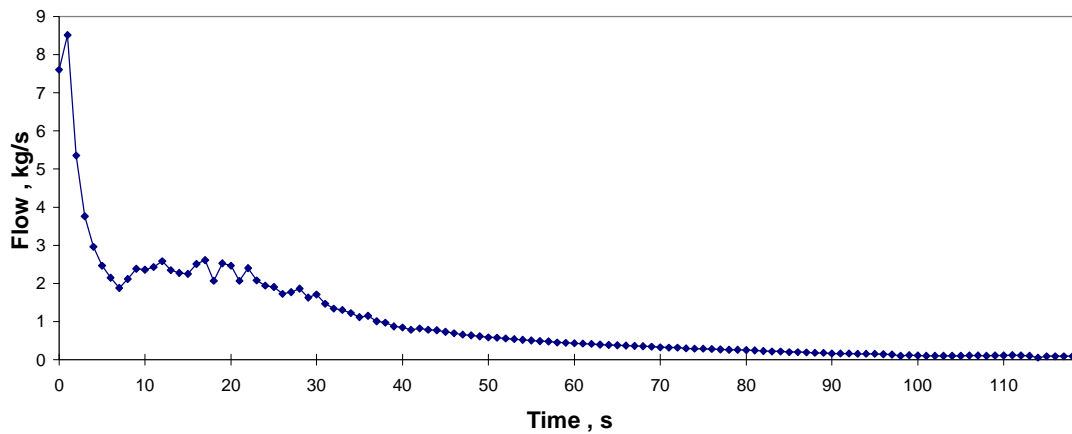

**Figure 3.** Helium mass flow out of the cold mass after a full-current quench of the prototype string (measured).

### CALCULATION OF HELIUM STATE IN LINE D AFTER A QUENCH

We use the measured helium enthalpy  $h(t)$  and flow  $\dot{m}(t)$ , shown in Figures 2 and 3, as an input to calculate the helium thermodynamic state in line D after a quench. The heat capacity of line D is negligible in comparison to that of the helium. Therefore for a given number  $n$  of half-cells quenched, Eq. (1) takes the form:

$$dU = n \cdot h(t) \cdot \dot{m}(t) dt \quad (4)$$

The calculated time evolution of helium temperature, pressure and vapour quality in line D after a whole sector (54 half-cells) quench is shown in Figures 4 - 6.

### Steady-state Thermodynamic Parameters of Helium in Line D

The thermodynamic parameters of helium in line D will reach steady state several minutes after a quench. The temperature and pressure will then depend on the number of

half-cells quenched, with the enthalpy  $\bar{h}_{He}$  and mass of the discharged helium from one half-cell  $\Delta M_{He-ex}$  as parameters - see Figure 7. The pressure in line D is limited to 2 MPa as it was designed for<sup>1</sup> and established by previous work<sup>3</sup>. Line D forms a buffer which can accumulate expelled helium if the number of half-cells involved does not exceed 44. For a higher number of half-cells quenched some helium must be discharged from line D.

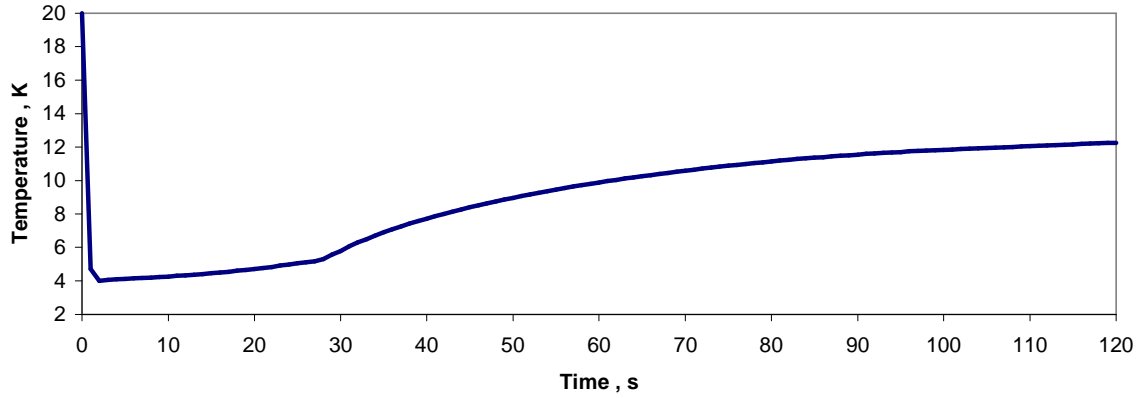

Figure 4. Temperature in line D after a whole sector (54 half-cells) quench (calculated).

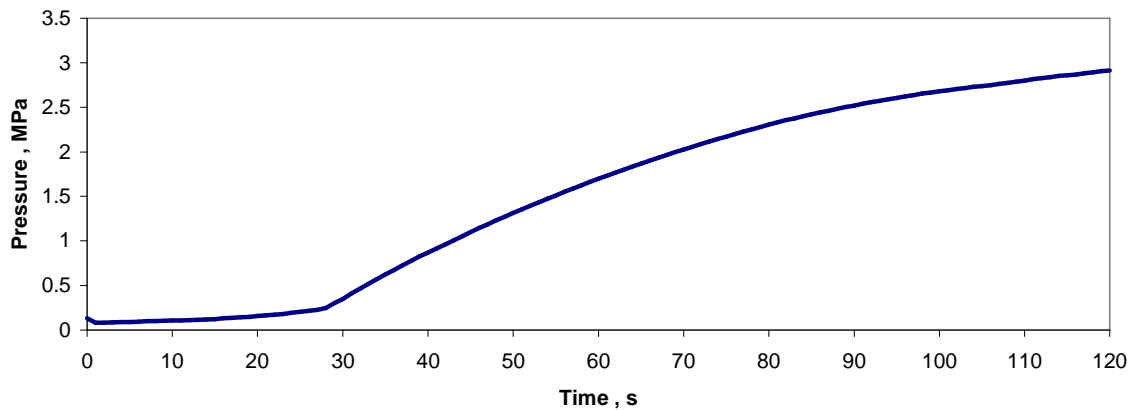

Figure 5. Pressure in line D after a whole sector (54 half-cells) quench (calculated).

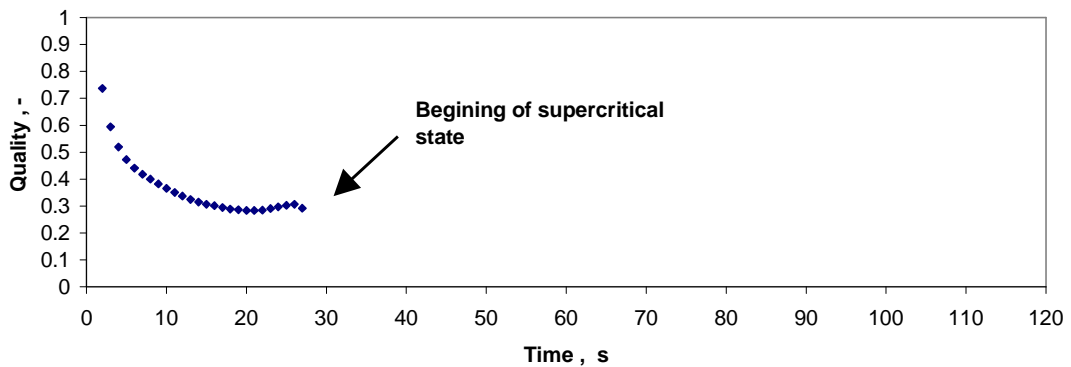
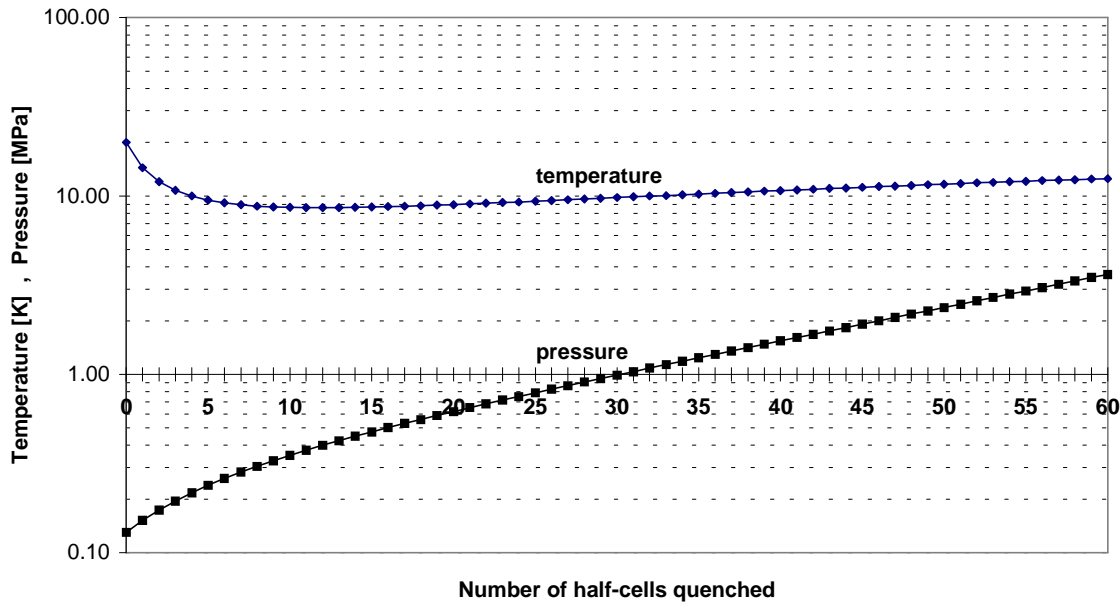

Figure 6. Vapour quality in line D after a quench of 54 half-cells (calculated).



**Figure 7.** Calculated temperature and pressure in line D as a function of the number of half-cells quenched, average enthalpy of the discharged helium is 33 J/g, mass of helium discharged from one half-cell is 120 kg.

### LHC Quench Classification.

According to the number of half-cells involved, LHC quenches can be classified from their cryogenic consequences as:

- Limited quench (2-12 half-cells quenched). After a limited quench no liquid helium is present in line D during the cold mass discharge, maximal pressure in line D is equal to 0.42 MPa after a quench of 12 half-cells. A limited quench can be fully buffered by the capacity of line D.
- Medium quench (13-44 half-cells quenched). A medium quench is characterised by liquid helium present during discharge in line D for some time and maximal pressure 2 MPa (for 44 half-cells quenched). Due to the quench propagation considerations a medium quench is assumed to be a highly improbable event.
- Whole sector quench (45-54 half-cells quenched). A sector quench cannot be fully buffered by the capacity of line D and a fraction of helium must be discharged to medium-pressure gas tanks (Fig.1.5).

### HELIUM RECOVERY IN MEDIUM-PRESSURE GAS TANKS.

As follows from the calculation of the helium parameters in line D following a quench, only in the case of a whole sector quench is the capacity of line D too small to contain (even for a short time) all the helium expelled from the cold mass and a fraction of helium must be buffered in the medium-pressure tanks. The medium-pressure tanks are made of carbon steel, which constrains the temperature of the wall to be higher than -40 °C. This means that the in-flowing helium stream should be warmed up. We have considered two convenient passive sources of heat:

- Convective heating on the line connecting line D to the MP gas tanks (Fig.1.4),

- Heat capacity of the medium-pressure gas tanks (Fig.1.5).

Figure 8 shows the temperature of the helium inside the tank and the tank wall calculated for the following conditions:

1. Total quench buffer volume is  $2000\text{m}^3$  and its heat capacity is 203 MJ/K.
2. Initial helium temperature in is 253 K and initial pressure is 100 kPa.
3. Line D is discharged through a valve opening on pressure and set at 1 MPa, integrated helium flow to medium-pressure tank after a whole sector quench is 2340 kg, maximal instantaneous flow is 20 kg/s, time evolution of helium temperature and pressure in line D is given in reference<sup>4</sup>.
4. Convective heating power on the vertical uninsulated line is estimated at 17 kW.
5. Heat transfer coefficient between tank wall and helium is estimated at  $58\text{ Wm}^{-2}\text{K}^{-1}$ .
6. Heat transfer coefficient between the tank wall and ambient air is estimated at  $10\text{ Wm}^{-2}\text{K}^{-1}$ .
7. Ideal mixing of helium occurs inside the tanks and no temperature gradient is developed across the tank wall.

The temperature of the tank wall decreases by 8 K only, reaching 245 K, and remains well above its lower limit (233 K). This means that the tank heat capacity is high enough to warm up the in-flowing helium and to prevent the tank wall against dangerous temperature drop with a 150 % safety margin. Nevertheless it must be stressed that the heat capacity of the tanks can be fully used only if a good mixing of helium inside the tanks is achieved e.g. by use of an appropriate tank inlet pipe-work, preventing jet formation and spot cooling of the tank wall.

## HELIUM INVENTORY AND EXERGY RECOVERY AFTER A QUENCH

From the LHC operation point of view, there are two probable sizes of quenches to be considered:

- Limited quench - it starts in one magnet and propagates to the adjacent magnets due to the inter-magnet quench propagation (up to 8 half-cells involved). A limited quench is considered as a part of the collider operation.
- Whole sector quench - all sector magnets quench simultaneously (46 - 54 half cells involved). A whole sector quench is considered as an accidental mishap.

In case of a limited quench, line D can fully buffer helium expelled from the LHC cold mass. Both helium inventory and its refrigeration capacity are then recovered.

In case of a sector quench a fraction of the expelled helium (up to 30%) must leave line D, be warmed up and stored in medium-pressure gas tanks. The temperature of helium leaving line D is below 12 K and the fluid is characterised by high exergy which is lost during warm up. As the sector refrigerator will be ready to start blowing down vacuum insulated line D about 10 minutes after the quench, the line will store the remaining helium for that period of time. The maximum flow capacity to blow down line D to the refrigerator may vary from 780 g/s to 260 g/s. If we assume that about 5000 kg of helium should be recovered from line D, it would be necessary to run the refrigerator compressors for 2 to 6 hours. After a sector quench it is then possible to recover all the helium inventory and about 70% of its exergy.



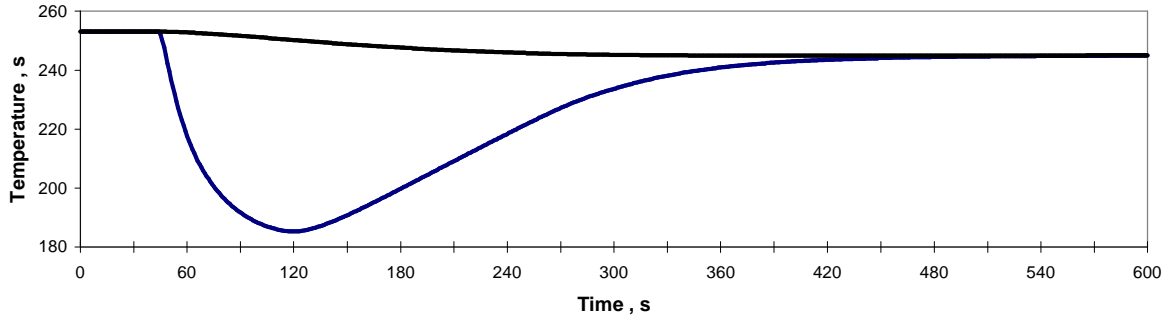

**Figure 8.** Calculated wall and helium temperature in medium-pressure tank during discharge of line D, initial temperature and pressure 253 K and 1 bar respectively.

## CONCLUSIONS

1. For the purpose of configuring and sizing the LHC helium recovery system a lumped-parameter model based on energy balance is applicable.
2. The probable LHC quenches can be classified from their cryogenic consequences as:
  - limited quenches, up to 12 half-cells involved, no liquid helium present in line D during discharge, can be buffered by the capacity of line D, will be part of the machine operation,
  - sector quenches, 45-54 half-cells involved, considered as accidental mishap.
3. In case of a sector quench line D is not able to accommodate all the helium expelled, and a fraction of the helium (up to 30%) will have to be warmed up and stored in the medium-pressure gas tanks. The exergy of this helium is lost.
4. The heat capacity of the medium-pressure tanks is high enough to warm up the in-flowing helium and to prevent the tank wall temperature from dropping below the design value.
5. To avoid local temperature drop of the tank wall below a design limit ( $-40\text{ }^{\circ}\text{C}$ ), a good mixing of helium must be achieved by use of a appropriate pipe-work inside the tanks.

## ACKNOWLEDGEMENTS

The authors would like to thank Philippe Lebrun for many helpful suggestions and his thorough proof-reading.

## REFERENCES

1. The LHC Study Group, The Large Hadron Collider Conceptual Design, CERN/AC/95-05(LHC).
2. A. Bézaguet et. al., Cryogenic Operation and Testing of the Extended LHC Prototype Magnet String, Proc. ICEC 16/ICMC, Kitakyushu, Japan, May 1996.
3. L. Brue, Modélisation Thermohydraulique des Ecoulements Transitoires d'Hélium Cryogénique induits dans la Ligne de Récupération du Demi-Octant par les Transitions Résistives des Aimants du LHC, LHC Note 262, CERN AT/94-03 (CR).
4. M.Chorowski, Transient behaviour and helium recovery in the LHC cryogenic system following magnet resistive transitions, LHC Project note 77, CERN/LHC (1997).