

EUROPEAN ORGANIZATION FOR NUCLEAR RESEARCH
European Laboratory for Particle Physics

Large Hadron Collider Project

LHC Project Report 108

STATE OF THE LHC MAIN MAGNETS

R. Perin for the LHC Magnet Team

Abstract

The main features of the dipole magnet design have been frozen in 1996 and important steps for the preparation of their series production are being taken in the current year. To finalize the technical specifications of the superconducting cables and other components, a number of detail variants are being validated with the construction and test of short and long magnets. Thus, beside a number of 1 m long models, four 10 m long models of the main dipoles and two 14.2 m prototypes are being assembled in industry and at CERN. The fabrication of a further set of 3 full length dipoles is also starting in industry to verify the reproducibility of production and performance.

The lifetime and fatigue test of the String Test Facility, consisting of three dipoles and one quadrupole and simulating the basic periodic cell of the LHC, has been successfully concluded. The String was repetitively cycled between the injection field of 0.6 T and the operational field of 8.4 T, 24 hours per day, and has accumulated more than 2100 cycles, corresponding to about ten years of machine operation.

The final design of the main quadrupoles, based on the use of the dipole coil outer layer cable, is being worked out by CEA, Saclay and the construction of two new prototypes has been launched.

PAC'97, Vancouver

Administrative Secretariat
LHC Division
CERN
CH - 1211 Geneva 23
Switzerland

Geneva, 30 May 1997

STATE OF THE LHC MAIN MAGNETS

R. Perin for the LHC Magnet Team

Abstract

The main features of the dipole magnet design have been frozen in 1996 and important steps for the preparation of their series production are being taken in the current year.

To finalize the technical specifications of the superconducting cables and other components, a number of detail variants are being validated with the construction and test of short and long magnets. Thus, beside a number of 1 m long models, four 10 m long models of the main dipoles and two 14.2 m prototypes are being assembled in industry and at CERN. The fabrication of a further set of 3 full length dipoles is also starting in industry to verify the reproducibility of production and performance.

The lifetime and fatigue test of the String Test Facility, consisting of three dipoles and one quadrupole and simulating the basic periodic cell of the LHC, has been successfully concluded. The String was repetitively cycled between the injection field of 0.6 T and the operational field of 8.4 T, 24 hours per day, and has accumulated more than 2100 cycles, corresponding to about ten years of machine operation.

The final design of the main quadrupoles, based on the use of the dipole coil outer layer cable, is being worked out by CEA, Saclay and the construction of two new prototypes has been launched.

1 INTRODUCTION

The main magnetic components of the LHC i.e. the 1232 dipoles and the 386 quadrupoles of the lattice have already been described in several publications [e.g. 1,2], so that only the recent evolution in their design and the present state of advancement towards their procurement are reported here.

2 DIPOLES

2.1 Design evolution

Since 1995 the design of the magnets, though maintaining the main features, evolved partly to adapt to changes in the design of the machine and partly as a result of the R&D programme on short and long magnets.

Inter-beam distance

The distance between the centres of the two apertures has been increased from 180 mm to 194 mm. This change was motivated by space considerations in the RF sections and by the desire to diminish both the spring back of the collars when releasing the press after collaring and the tensile stress concentration around the central dowel rod hole. In fact the collar central "leg" appeared to be rather weak as compared to the side "legs". With this modification the final pre-stress in the central and in the lateral parts of the coils is better balanced and the spring back after collaring has been reduced by 20 %. This

allows to apply a lower compression under the press with less danger of damaging the coils and easier production. This increase of the inter-beam distance did not require an increase of the overall cold mass diameter which remains unchanged (ϕ 570 mm) (fig. 1).

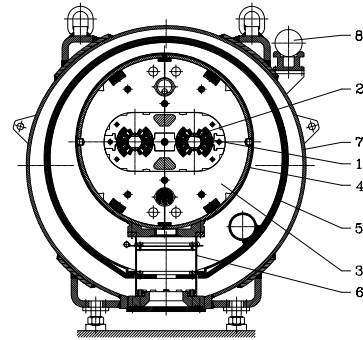

1. Beam Screen, 2. Cold bore, 3. Cold mass at 1.9 K, 4. Radiative insulation, 5. Thermal shield (55 to 75 K), 6. Support post, 7. Vacuum vessel, 8. Alignment target

Figure 1: Cross-section of LHC dipole

Dimensions of the superconducting cables

The compaction of the previous cables was found to be too high especially at the thin edge where it was difficult to avoid sharp edges that could damage the insulation. A slight reduction in compaction was also found to be favourable to penetration of liquid helium and better wetting of the strands, thus improving heat transfer to helium and heat capacity and consequently increasing the amount of energy needed to provoke a quench [3]. The compaction was, therefore, reduced by about 2 % and at the same time the keystone angles were also slightly diminished, resulting at present 1.25° in the inner shell cable and 0.90° in the outer shell cable. The new parameters of the cables are listed in table 1.

	Inner layer	Outer layer
Strand		
Diameter (mm)	1.065	0.825
Cu/Sc ratio	1.6	1.9
Filament size (μ m)	7	6
Twist pitch (mm)	25	25
Critical current (A)		
at 10 T, 1.9 K	≥ 515	-
at 9 T, 1.9 K	-	≥ 380
Cable		
Number of strands	28	36
Cable dimension		
width (mm)	15.1	15.1
thin/thick edge (mm)	1.736/2.064	1.362/1.598
Transposition pitch (mm)	110	100
Critical current (A)		
at 10 T, 1.9 K	≥ 13750	-
at 9 T, 1.9 K	-	≥ 12950

Table 1: Dipole strand and cable characteristics

Field quality

The problems related to field quality are continuously studied from the points of view of beam optics and dynamics and magnet construction. Understanding is improving with the growing information from tests and measurements of short and long model magnets. Data are accumulating and being analysed on the effects of persistent currents, eddy currents, time dependence and influences of previous history and excitation cycle. It has been decided to compensate the b_5 (decapole), b_7 (14-pole) and b_9 (18-pole) field multipoles produced by persistent currents at injection by modifying the conductor distribution in the cross-section which was then re-optimised for this purpose. It is recalled that small sextupole and decapole magnets located at each dipole end can compensate systematic errors of those two components.

2.2 State of R&D programme

The R&D programme, which has validated the main design features, will continue until the start of the series production of the final dipoles with the aims to improve quench behaviour, field quality and economy of construction. It will terminate with the final trimming, in particular of the coil geometry to obtain the wanted field quality, during the production and measurement of the pre-series magnets.

Superconducting cables

About 10 t of superconducting cable of the new design have been produced by industry, thoroughly measured and qualified. They meet the specifications in all respects, current carrying capacity, dimensional tolerance and mechanical characteristics, and have also been tested in short dipole models. This has permitted to order a quantity sufficient to start the pre-series production of the final magnets. Investigations are still intensively carried out on different coatings of the strands, so as to obtain a uniform and reproducible interstrand resistance in the range 10 to 20 $\mu\Omega$ per crossing contact, necessary to limit field errors and heat generation by eddy currents at ramp. The interstrand resistance is difficult to control as it depends not only on the coating material, but also on storage conditions, temperatures and pressures in the curing cycle and pre-stress in the coils [4]. At present the best results are obtained with staybrite (Ag 3.5 %, Sn 96.5 %) coating and a special heat treatment in argon atmosphere.

Conductor insulation

Several conductor insulation systems have been investigated from the points of view of heat transfer and porosity to helium to take advantage of its excellent cooling properties [5], while ensuring a good dielectric barrier between turns. An all polyimide system has been chosen, but different tapes and layouts (thickness, width, overlap, spacing) are still being tested in short model magnets with the aim to further improve permeability to superfluid helium.

Models and prototype magnets

The programme of magnet construction proceeds in parallel on three lines: short (1.3 m long) models, 10 m long models and prototypes of the final length (magnetic length 14.2 m). At CERN a dedicated workshop manufactures single and twin aperture short models [6]. The so called Coil Test Facility, in fact a single aperture magnet structure conceived for easy assembly and disassembly, is a time-and-cost-effective means of studying different versions of coil construction as e.g. different types of end spacers, layer jumps, conductor insulation systems, strand coating and assembly methods. One important observation, which confirms earlier finding in the SSC magnet development program [7], is that in some of the best behaving magnets the azimuthal compression in the coil at the coil collar pole interface had completely disappeared at fields well below the field finally reached by the magnet. An investigation has, therefore, been started to determine the optimum pre-stress to be applied since there is no point to collar coils at pre-stress values above what is needed, as this can only make the fabrication more difficult and increase the risk of damaging the insulation.

As previously reported [8, 9, 10], other successful dipole development was carried-out by collaborating laboratories, as the CERN-Finnish-Swedish version 1 m model, the models built by KEK and Japanese industry and the Nb_3Sn high field model of Twente University.

Last year an assembly facility for full length dipoles has been put into operation at CERN. This is now used to assemble 10 m long models starting from coils wound and collared in industry and will be soon employed to assemble final length magnets. The main purpose of this work at CERN is to study and finalize important details of the assembly procedures, such as e.g. economical and efficient welding methods for the shrinking cylinder, the way to obtain the wanted curvature of the magnets, the optimization of the electrical connections.

Four 10 m long magnets of the second generation (aperture 56 mm) are at present being completed, the first one, mounted in a cryostat of the first generation dipoles, is already being tested. A second one will follow at a month interval and the other two will be tested in the second half of the year.

The first full length (~ 15 m, magnetic length 14.2 m) prototype, funded and built in the framework of a collaboration with Istituto Nazionale di Fisica Nucleare (INFN), is in advanced state of construction (fig. 2) and is expected to be delivered to CERN in October 1997. It will be followed by four collared coil assembly manufactured in industry, which will be finally assembled into finished magnets partly at CERN and partly in industry.



Figure 2: Collared coils of the first 15 m long magnet (courtesy of Ansaldo Energia S.p.a.)

LHC prototype half-cell

A major milestone in the project has been the assembly of a magnet string facility, consisting of one short straight section and three 10 m dipole magnets connected electrically and cryogenically together on a slope of 1.4 %, in simulation of the LHC conditions. The string has undergone already several thousand hours of operation with more than 80 provoked quenches and several thermal cycles with full success. It has been powered with LHC like ramping cycles between injection and 8.4 T field for more than 2'000 cycles simulating about 10 years of the collider operation [11].

2.3 Towards the series production

Final drawings and detailed technical specifications are being prepared for the main magnet cables and for the manufacturing of the magnets. An important order for the supply of 50'000 tonnes of low-carbon steel sheet for all main dipoles and quadrupoles has already been placed. It is hoped to order the superconducting cables before the end of this year. Market surveys for several other materials and components as well as for the supply of the main dipole cold masses have already been carried out and calls for tenders are expected to be issued in the course of this and next year.

The LHC planning, largely dominated by the main dipole magnets, foresees to place the main orders for their supply in 1998. They will include the manufacturing of a number of pre-series magnets (at least 10 per manufacturer) whose delivery to CERN will start in 1999 and terminate in the year 2000. After their thorough test, measurement and evaluation, the green light for mass production could be given by mid 2001.

3 QUADRUPOLES

The main parameters of the quadrupoles are gradient 223 T/m, coil aperture 56 mm and magnetic length 3.1 m. Their cross-section is shown in fig. 3.

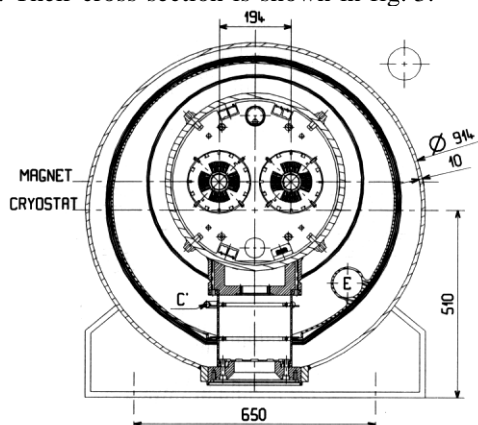

Figure 3: Cross-section of the LHC main quadrupole

The design [12] is based on the use of the same cable as for the dipole outer layer. This should result in some saving because possible broken length of dipole cables could be used for the quadrupoles which require much shorter stretches of conductor.

Their main constructional features are: two layer coils made from a single stretch of cable, austenitic steel collars supporting the full electromagnetic forces and a "two-in-one" yoke structure held by an outside stiffening cylinder, which also serves as helium vessel and support for the correction magnets and other components of the short straight sections. The 12-pole field error component produced by persistent currents at injection is for a large part (> 80 %) compensated by a special layout of the conductors in the cross-section.

The development of the quadrupoles has been from the beginning entrusted to CEA, Saclay in France. This has resulted in the construction of two 3.06 m (magnetic length) real size quadrupoles which have been successfully tested at Saclay and delivered to CERN. In the frame of a special contribution of France to LHC, CEA will ensure the development and test of two further prototype of the new design. CEA will then be responsible for the technical specification and the follow up of fabrication in industry of the series quadrupoles. The remaining R&D programme foresees delivery to CERN of the two new prototypes, already tested, in autumn 1998.

4 REFERENCES

- [1] The LHC Study Group, The Large Hadron Collider, Conceptual Design, CERN/AC/95-05 (LHC).
- [2] R. Perin, Superconducting Magnets for the Large Hadron Collider, CERN LHC Project Report 52, 8 October 1996.
- [3] M.N. Wilson, W.B. Sampson and A.K. Ghosh, Experimentally measured Minimum Quench Energies of LHC cables, CERN LHC Project Report 86, 15 January 1997.
- [4] D. Richter et al., DC Measurement of Electrical Contacts between Strands in Superconducting Cables for the LHC Main Magnets, Proc. 1996 Applied Superconductivity Conference, Pittsburg, 25-30 August 1996.
- [5] L. Burnod et al., Thermal Modelling of LHC Dipoles functioning in Superfluid Helium. Proc. EPAC'94 Conference, London and CERN AT/94-21.
- [6] N. Andreev et al., The 1 m long Single Aperture Dipole Coil Test Program for LHC, Proc. EPAC'96, Sitges, (Barcelona), June 1996.
- [7] P. Wanderer et al., Effect of Prestress on Performance of a 1.8 m SSC R&D Dipole, presented at ISSC Atlanta, March 13-15, 1991.
- [8] J. Ahlbäck et al., Construction of a 56 mm Aperture High-Field Twin-Aperture Superconducting Dipole Model Magnet, Proc. MT14, IEEE Trans. on Magnetics, Vol. 30, July 1994.
- [9] T. Shintomi et al., Development of a 56 mm aperture Superconducting Dipole Model Magnet for LHC, Proc. 1996 Applied Superconductivity Conference, Pittsburg 25-30 August 1996.
- [10] A. den Ouden et al., An Experimental 11.5 T NB_3Sn LHC Type of Dipole Magnet, Proc. MT13, IEEE Trans. on Magnetics, Vol. 30 No. 4, July 1994.
- [11] R. Saban et al., Experiments and cycling at the LHC Prototype Half-Cell, PAC'97, Vancouver, 12-16 May 1997.
- [12] T. Tortschanoff et al., The Short Straight Sections for the LHC, PAC'97, Vancouver, 12-16 May 1997.