

EUROPEAN ORGANIZATION FOR NUCLEAR RESEARCH

CERN/DRDC/91-41
DRDC/P31
October 9, 1991

Optoelectronic Analogue Signal Transfer for LHC Detectors

J.D. Dowell, P.M.Hattersley, R.J. Homer, P. Jovanovic, I. Kenyon, R. Staley, K.Webster
School of Physics and Space Research, University of Birmingham, UK

C. Da Via, J. Feyt, P. Nappey, G. Stefanini
CERN, Geneva, Switzerland

B. Dwir, F. K. Reinhart
Ecole Polytechnique Fédérale de Lausanne, Switzerland

J.Davies, N.Green, W. Stewart, T.Young
Marconi Defence Systems, A Management Company for GEC-Marconi Ltd., Stanmore, UK

G. Hall
Imperial College, London, UK

T. Akesson, G. Jarlskog, S. Kröll
University of Lund, Sweden

R. Nickerson
Department of Nuclear Physics, Oxford University, Oxford, UK

S. Jaroslowski
Rutherford Appleton Laboratory, Didcot, UK

Spokesman: G. Stefanini

Abstract

We propose to study and develop opto-electronic analogue front-ends based on *electro-optic intensity modulators*. These devices translate the detector electrical analogue signals into optical signals which are then transferred via *optical fibres* to photodetector receivers at the remote readout. In comparison with conventional solutions based on copper cables, this technique offers the advantages of high speed, very low power dissipation and transmission losses, compactness and immunity to electromagnetic interference. The linearity and dynamic range that can be obtained are more than adequate for central tracking detectors, and the proposed devices have considerable radiation-hardness capabilities. The large bandwidth and short transit times offer possibilities for improved triggering schemes.

The proposed R&D programme is aimed at producing multi-channel “demonstrator” units for evaluation both in laboratory and beam tests. This will allow the choice of the most effective technology. A detailed study will also be carried out on packaging and interconnection to large arrays of fibres, as well as on the optimization of the processes for the production of large quantities.

Contents

1. Introduction

2. General System Considerations

- 2.1 Radiation hardness
- 2.2 Power dissipation and cabling
- 2.3 Trigger capabilities
- 2.4 Reliability and cost

3. Electro-Optic Modulators: An Overview

- 3.1 LiNbO₃ Modulator: The Mach-Zehnder Interferometer
- 3.2 Semiconductor Modulator: Multiple Quantum Well (MQW) Structures

4. The Optoelectronics R&D Program

- 4.1 Objectives - Connections with Industry
- 4.2 Evaluation of Standard Devices
- 4.3 Design and Development of Modulator Arrays
 - 4.3.1 Lithium Niobate Technology
 - 4.3.2 III-V Semiconductor Technology
 - 4.3.3 General Comments
- 4.4 Laboratory and Beam Tests
- 4.5 Study of Production Processes

5. Timescale

6. Sharing of Responsibilities

7. Budget Considerations

- 7.1 Overall Budget
- 7.2 Proposed Cost Sharing

APPENDIX A: Detector Signal Considerations

References

Figure captions

1. Introduction

The detector configurations presently envisaged for LHC will require the readout of up to 10^7 channels, with the front-ends subject to high radiation levels in a practically hermetic enclosure. This raises a major challenge, in particular for the architecture of the front-ends and for the actual implementation, cooling and cabling.

A high degree of parallelism in signal transmission and processing will be required in general for the first level trigger, as well as whenever a particle identification signal is to be made available in the trigger architecture. This is the case for the TRD detector (electron identification), which prompted our investigations.

The central tracking detectors will probably use multiplexed analogue pipelines before readout. However, in this case too a number of channels will have to be processed at very high speed, in order to retain some first level trigger capability.

Common requirements for the front-ends in these detectors are a modest dynamic range ($< 500:1$) with deviations from linearity contained within $\lesssim 1\%$.

These requirements, together with the overall constraints, suggest that it would be of considerable interest to develop a technique by which the bulk and complexity of signal handling devices and cables on the detector would be minimized, and by which the analogue signals could be transferred to the remote readout electronics over fast links.

We propose to address this challenging issue by using *electro-optic intensity modulators* - devices that use the detector electrical signals to modulate the intensity of CW laser beams originating outside the detector volume. The analogue electrical signals are linearly translated into optical signals which are then transferred to the remote readout via *optical fibres*.

This technique is applicable to all LHC detectors generating electrical signals, with the exception of calorimeters, where the dynamic range required is much larger. In comparison with conventional solutions based on copper cables and driving circuits, this technique offers a number of advantages:

- a) the integrated-optics devices and silica fibres are expected to have suitable radiation hardness capabilities;
- b) both the uninstrumented detector volume and the power dissipation at the detector are minimized, and the transmission losses are negligible;
- c) “lightwave” links are considerably less bulky than copper cables, offer immunity to electromagnetic interference, and avoid ground loops;
- d) the fibres can be used as part of the analogue pipelines;
- e) the devices can have a very large bandwidth (up to several GHz), which offers the possibility of efficient signal multiplexing.

Electro-optic intensity modulators are commercially available in single-channel form, and multi-channel prototypes are in the advanced development stage. We intend to investigate the feasibility of compact and reliable multi-channel integrated-optics devices that would be needed to match the high density of channels in a LHC detector.

The aim of the proposed R&D programme is to design and produce “demonstrator” units, in two alternative technologies, for evaluation both in laboratory and in beam tests. This will eventually lead to the choice of the most effective technology. A detailed study will also be carried out on packaging and interconnection to large arrays of fibres, as well as on the optimization of the production processes for the large quantities required for LHC detectors.

The Transition Radiation Detector collaboration [1], the Tracking/Preshower collaboration [2], and the Silicon [3] and Gallium Arsenide [4] Tracking collaborations have all expressed an interest in the development and are prepared to participate in the tests.

Planning of the programme indicates that it would be completed in approximately two years from the date that funding was assured.

2. General System Considerations

The motivation for investigating the use of lightwave components (electro-optic modulators and optical fibres) in the front-end is based on the following considerations.

2.1 Radiation hardness.

The electro-optic modulator technologies that we take into consideration are based on lithium niobate crystals (LiNbO_3) or III-V semiconductors (GaAs, InP-based). Available data [5] give supporting evidence that both materials and technologies should operate without significant degradation through the lifetime of an LHC experiment, where the integrated dose and neutron fluence in the inner cavity are estimated to be $\dot{\text{A}} 100 \text{ KGy}$ and $\dot{\text{A}} 10^{14} \text{ neutrons/cm}^2$, respectively (over 10 years, at a luminosity of 10^{34} cm^{-2} , pseudorapidity $\eta \approx 2.5$, radius of 1 metre). Radiation-hard silica fibres for digital signal transmission are commercially available [6].

2.2 Power dissipation and cabling.

The large number of channels ($\dot{\text{A}}10^7$) and the desired hermeticity of the detector imply that the power dissipation per channel should be kept as low as possible, to avoid major cooling problems. Furthermore, in a conventional copper cable approach, the bulk volume of the cables limit the volume of the detector that is active.

In contrast, E-O modulators are relatively passive devices presenting a capacitive load of \AA 1pF to 10pF to the driver. They can be driven directly by the detector signal, if this is sufficiently large (see sect. 3.1), or by a suitable preamplifier with very small power requirements. The laser beam, which acts as a carrier of the modulated signal, is located outside the detector in the readout electronics area. We presently estimate that, for each channel, the electrical driver power can be as low as \AA 0.2 mW (average), while the cw laser optical power can be limited to \AA 0.50 mW (generated outside the detector).

These low power levels make the devices suitable for the application in cryogenic detectors. In particular, the III-V devices have shown quite large improvements in performance at low temperatures, both in sensitivity and power consumption, and optimized devices will show much greater gains.

Optical fibres links require considerably less volume than the copper equivalents. In addition, they are insensitive to electro-magnetic interference and avoid cross-talk and ground-loop problems.

2.3 Trigger capabilities.

As outlined in the introduction, first level triggers and particle identification processors require a high degree of parallelism in signal transmission and processing. Fast analogue optical fibre links are well suited to this purpose. In the case of central detectors, the fibres can be part of the analogue pipeline. This technique may allow the removal of power-hungry fast digitizers from the detector front-end to remote electronics. More generally, electro-optical modulators are capable of very large bandwidth (several GHz); different multiplexing schemes can be envisaged.

2.4 Reliability and cost.

These are clearly key issues for large quantity application at LHC. A close collaboration with Industry is necessary to assess the most effective solutions. The use of components developed for the Telecom market, such as lasers and silica fibres for $\lambda = 1.3 \mu\text{m}$, should allow us to profit from the low component cost. In the development programme, these aspects will be thoroughly investigated in connection with production processes.

In the following section, the characteristics of the E-O modulators are described for two available technologies, and relevant system aspects are discussed.

3. Electro-Optic Intensity Modulators: An Overview

The general characteristics of electro-optic intensity modulators that are particularly relevant for our proposal will be reviewed in this section. Several specific aspects will be analysed in

greater detail in a later section. Two alternative technologies ([7],[8]) are being considered for investigation:

a) Lithium Niobate (LiNbO₃) Mach-Zehnder interferometer. This technology is well established; the design and development of a device in array form with 16 (possibly up to 64) channels can be completed in less than a year.

b) III-V semiconductors (GaAs, InP-based) multiple quantum well (MQW) devices. This technology is somewhat less mature but offers the possibility for signal processing to be built on the same substrate as the modulator, and is also well suited for producing high density array devices.

3.1 LiNbO₃ Modulator: the Mach-Zehnder Interferometer

In its present form, commercially available and principally used in Telecom and instrumentation applications, this is an integrated optics one-channel device, which consists of a Lithium Niobate substrate into which Ti waveguides have been diffused. Optical fibre pigtailed provide input and output. The structure of device is shown in fig. 1.

The operation of the intensity modulator can be outlined as follows. Light from a CW laser, launched into the single-mode input fibre, is split equally into the two waveguides that form the interferometer arms and recombined at the output. (The plane of polarisation of the input lightwave is defined by a laminated polariser or by using a polarisation-preserving fibre). The lengths of the two arms are identical, within fabrication tolerances, and are typically $\dot{\text{A}}$ 15 mm. A voltage - in this case, the detector signal - applied to the central electrode creates electric fields of opposite sign across the two waveguides, with changes in opposite senses of the local refractive index. The induced difference ϕ in the relative phase of the two beams leads to interference, i.e. to amplitude modulation in the outgoing lightwave.

The ratio of the output to the input optical power is given by:

$$P_0/P_i = 1/2(1 + \cos \phi) = 1/2[1 + \cos(\phi_i + \pi V/V_\pi)]$$

where

ϕ_i intrinsic residual phase difference ($\dot{\text{A}}$ $\pi/2$, within fabrication tolerances)

V input voltage

V_π voltage change corresponding to $\Delta\phi = \pi$ ($V_\pi \dot{\text{A}}$ 1 to 6 V, depending on design)

For linear response, the device is used at the quadrature point, i.e. at $\phi_i = \pi/2$, by applying a small dc voltage bias via a bias-tee ($V_b \dot{\text{A}}$ 0.5 V, typically). Then, using $\delta V = (V - V_b)$, we get:

$$P_0/P_i = 1/2(1 - \sin \pi\delta V/V_\pi) \dot{\text{A}} 1/2(1 - \pi\delta V/V_\pi) \text{ for } \delta V \ll V_\pi.$$

Therefore, the electrical input signal is converted into an optical output signal, which can be transmitted with low loss on optical fibres and recovered at the receiving end by a photodetector. An integral non-linearity of $\lesssim 1\%$ can be obtained by restricting the electrical modulation amplitude to $\delta V < (0.25/\pi)V_\pi$.

Figures. 2 (a) and 2 (b) show, respectively, the transfer characteristics and the linearity response of a non-optimized ($V_\pi = 6V$) commercial single channel Mach-Zehnder intensity modulator, measured at CERN [9] with the experimental setup shown in fig. 3. A dynamic range of 500:1 was obtained with an integral non-linearity limited to $\lesssim 1\%$. The results are similar to those obtained by Radeka et al. [10]. Their detailed noise analysis shows that, with a suitable pulse shaping (time constants $\lesssim 20$ ns) and an average photodetector current $I \lesssim 1$ mA, the dominating noise source is the photon statistics, and that the linearity requirements can be met over a dynamic range larger than 60 dB (10 bits equivalent).

The non-linear region of the transfer characteristics might also be used for signal compression, in order to increase the effective dynamic range.

When used with detectors signals, the modulator would be driven not by the voltage on a terminating resistor but rather by the detector signal charge. For a detector/modulator capacitance $C_d \lesssim C_m \lesssim 10$ pF, we find an equivalent input noise charge $Q_n \lesssim 3$ fC. By comparison with the data in Appendix A, it appears that some amplification of the input signal is needed for reliable detection. This amplification can be conveniently combined with pulse shaping to optimize the signal to noise ratio.

3.2 Semiconductor Modulator: Multiple Quantum Well (MQW) Structures

A Mach-Zehnder interferometer, similar to the one described in the previous section, can be implemented on bulk III-V semiconductors (GaAs, InP-based), with significant reduction in size and increase in sensitivity. Other semiconductor devices offer however attractive alternatives. The advances in crystal growth technology, particularly in molecular beam epitaxy, have resulted in the design and implementation of complex multi-layer heterostructures in which the electron states are confined in “quantum wells”. In the 1980’s it was discovered that strong electro-optic effects are generated in such heterostructures near the electronic band edge. Electro-optic multiple quantum well (MQW) structures based on these effects are now the subject of intense research. The major thrust for the development of these devices is for high speed optical interconnections.

The functionality of MQW intensity modulators can be implemented in several configurations. The reflective modulator is outlined below, but we are considering also other structures, such as Mach-Zehnder types based on BRAQWETS, that might offer a better performance/cost ratio.

The basic structure of MQW devices in III-V semiconductors, as shown in fig. 4, usually consists of a series of $\lesssim 50$ alternating matched layers of GaAs and $\text{Ga}_{1-x}\text{Al}_x\text{As}$ (where $x \lesssim 0.7$,

typically). The layer thicknesses are in the range 30 to 90 Å. The optical transmission spectrum of such a structure shows sharp excitonic absorption peaks near the band edge. The peaks are sensitive to an applied electric field. This effect, known as Quantum Confined Stark Effect (QCSE), can be used for electro-optic modulation.

The structure itself can be part of a modified integrated-optics Fabry-Perot cavity for optimum efficiency. The modulator is in this case a reflective vertical cavity device, i.e. the optical axis is perpendicular to the substrate. In our application, the fibre that conveys input light to the device is also used to return the modulated signal, which is detected via an optical splitter. The splitter and the laser source can be located remotely.

The MQW reflective modulator has the advantage of being insensitive to light polarisation, and the requirements on fibre alignments are less severe than in lithium niobate modulators. MQW waveguide devices have smaller size, lower capacitance and higher sensitivity than LiNbO₃ equivalents. They can be implemented in monolithic array form, and can be integrated with other semiconductor devices. The radiation hardness of these structures must be assessed carefully; preliminary tests show that it should be quite satisfactory for use at LHC.

The MQW technology is still “young” in comparison with that of lithium niobate. Devices have been designed, implemented and measured in the lab, but they are not yet available as standard commercial units. However, the likely and potential advantages of this technology are such that a well targeted feasibility investigation is justified.

4. The Optoelectronics R&D Program

4.1 Objectives - Connections with Industry

The capabilities of electro-optic modulators have been outlined in the previous sections; we have pointed out the advantages which can be derived from their application at LHC . We propose therefore to establish an R&D programme with the following objectives:

- a) to carry out an extensive laboratory evaluation of single-channel LiNbO₃ intensity modulators (standard devices, commercially available) and existing MQW modulator arrays;
- b) to design, develop and build prototype multi-channel devices, including optical fibre links and receivers, which would demonstrate the technologies and allow the choice of the most effective solution;
- c) to evaluate these demonstrators in laboratory and beam tests;
- d) to perform a detailed study of the engineering, packaging and production processes that are best suited to obtain large quantities of these devices at an affordable cost.

In view of the advanced technology involved and of the specific expertise required in the study of production processes, the project is configured as an HEP-Industry collaboration.

The HEP component of the collaboration will identify the parameters of the demonstrators which are specifically relevant for the application at LHC, assure the liaison with detector groups, and will be responsible for laboratory and beam tests.

The Optoelectronics Institute of the Ecole Polytechnique Fédérale (EPFL-Lausanne) has considerable expertise in III-V semiconductor MQW devices and has MBE processing capabilities. They will contribute in modulator structure design and in the investigation of material properties.

The industrial activity will be led by Marconi Defence Systems (Stanmore), with specific experience in wideband optoelectronic systems and general expertise in radiation hardness, environmental requirements, and reliability in complex systems. This will be complemented by lithium niobate integrated optic technology from the GEC-Marconi Research Centre (Great Baddow), and by III-V MQW technology from GEC-Marconi Materials Technology, formerly Plessey Research (Caswell).

The understanding with our Industry partner is that the usual copyright protections will apply to documents concerning certain aspects of these developments, as well as to the GEC-Marconi proprietary technologies.

The programme of work is described in the following sections.

4.2 Evaluation of Standard Devices

A preliminary phase of the programme consists in getting hands-on experience by the laboratory evaluation of existing, state-of-the-art devices, as they can be obtained on loan from the manufacturer. As already mentioned in sect. 3.1, some work on a GEC-Marconi lithium niobate modulator has recently been done at CERN, following previous similar investigations at BNL. A corresponding activity is being set up at Birmingham, where a parallel reference study of the direct modulation of laser diodes/LEDs by detector signals is also being carried out. GEC-Marconi will soon make available prototypes of MQW arrays which, as results of in-house developments for other purposes, are not optimized for our application but allow us to obtain hands-on experience with these devices. The following parameters will be measured:

- a) dynamic range, linearity and noise, at various light levels and for different shaping constants;
- b) short- and long-term stability of working point and modulation gain;
- c) sensitivity to magnetic fields and environmental factors;
- d) radiation hardness of materials, technologies and devices. For silica fibres, the effect of radiation-induced attenuation on analogue signal transmission will be carefully assessed.

Devices will be characterized before and after integrated dose of 300 KGy and neutron fluence of 3×10^{14} neutrons/cm². Irradiation can be carried out at Birmingham, CERN or RAL. The device recently tested at CERN has been irradiated at the Birmingham facility with a dose equivalent to \sim 2 weeks of LHC running at full luminosity. No measurable changes have been observed.

This evaluation procedure will constitute the benchmark for the specification and evaluation of the multi-channel devices, and will be under the responsibility of the HEP part of the collaboration.

4.3 Design and Development of Modulator Arrays

In this section we outline the basic design considerations and system aspects. This material is only preliminary as a detailed study has to be carried out, as part of the proposed programme. The treatment of the subject should be sufficiently informative to allow a sound evaluation of the interest of this work.

4.3.1 Lithium Niobate Technology

This technology is mature enough to allow the design and construction of a multi-channel array without major difficulties. The device is outlined in fig.5, while fig. 6 illustrates the system envisaged to transfer the signals generated by the detector elements to the remote electronics.

In the simplest configuration, the (AC-coupled) output of each detector element would be directly connected to the electrodes of a modulator channel, N of which are integrated onto a single chip together with a 1:N passive splitter and polariser. Each such multimodulator chip plus its laser source, remote receiver and the fibre interconnects is called an IOC (Integrated Optical Circuit) for convenience. The number of channels served by each IOC is determined primarily by the power budget and the signal to noise ratio desired; and also to an extent by considerations of reliability and yield in manufacture. A target value for N in a final system is between 32 and 64. As already stated, it will probably be necessary to include some preamplification and shaping either between the detector element and IOC, or as part of the IOC.

Separate connections are provided for the bias control point, determined by a laser-trimmed hybrid resistor network. This gives excellent bias point stability after an initial short settling period, during which the variations in the bias point are typically less than 5% of the applied voltage.

The main trade-off in the design for a given material is between the Mach-Zehnder arm length (and hence drive voltage and capacitance) and splitter excess loss. Typical values for the

voltage-length product needed for a phase difference of π at a wavelength of 1.3 μm are around 4 V-cm for standard x-cut devices in lithium niobate and an electrode capacitance of about 10 pF/cm. As an example, a 16 channel device can be expected to have a total (fibre in to fibre out) excess loss of < 4 dB, maximum drive voltage in the range 1-2V, and capacitance 10-40 pF.

The interconnect between the modulator and the remote receiver is via a 100-metre ribbon cable of standard monomode optical fibre. Correct polarisation is maintained at the modulator input by a simple feedback control of an electro-optic polarisation controller at the output from the CW laser source; this would be part of the IOC. This method is chosen in preference to using polarisation-preserving fibre between the laser and the modulator because of the improved reliability, reproducibility, and the availability of standard monomode fibre and connectors - which are also appearing in radiation-hard form [11]. This also confines the interconnect problem to providing one multiway array connector per modulator. The Telecom wavelength of 1.3 μm is preferred on the grounds of minimising component cost.

4.3.2 III-V Semiconductor Technology

Single crystals of III-V semiconductors can be grown in complex layer structures using technology well established for making both optoelectronic and electronic devices (and, of course, combinations of these). This enables the properties of the crystals to be optimized both electrically and optically for any particular application. In the case of electro-optic modulators the layer structure is used to confine/reflect the light and to deliver the electric field only where it is required, and can also be used in various ways to enhance the electro-optic effect. The full range of possibilities has yet to be explored, but the use of multiple quantum wells, either in direct Stark effect devices or in BRAQWETS form seems most appropriate.

The device structure which is at present being closely investigated is an MQW reflective asymmetric Fabry-Perot modulator (ASFP). This exists already and is very compact ($< 50 \mu\text{m}$ square). However, as already pointed out in sect. 3.2., other structures may be considered; a careful study of possible alternatives in the light of the system requirements will be the subject of the initial phase of this project. It is clear from the above that there is considerable freedom to optimize the devices.

The III-V reflective ASFP intensity modulator [12] is a vertical cavity device; it can be mounted directly at the end of the optical fibre which brings light to the detector from the laser source located at the remote electronics. The compact size, and the compatibility of the technology with large scale semiconductor device fabrication, make it a particularly attractive option, because large numbers of devices can be fabricated in a monolithic array. Furthermore the fibre alignment tolerances are less severe than for lithium niobate modulators.

Operation of the MQW intensity modulator relies on the electric field dependence of the optical absorption edge of a multiple heterostructure. To maximise the modulation effect, the heterostructure is placed in a Fabry-Perot cavity, where the mirrors of the cavity are formed by a

combination of grown quarter wavelength semiconductor layers and a deposited dielectric or metal mirror. In general, an asymmetric cavity is used with a very high reflectivity back mirror, and a lower reflectivity front mirror with reflection coefficient typically in the range 35-50% (see fig. 4).

Optimized cavity design should achieve a high modulation depth (>50% of the input signal) with reasonable linearity. However, present devices are optimized for maximum contrast (in effect for high extinction) and have lower modulation depths of $\sim 25\%$. A full multi-layer model has been established at GEC-Marconi Materials Technology, Caswell, so that the trade-offs can be evaluated in detail. For devices fabricated to date, values of reflectance change $\Delta R \sim 6\%/V$ have been demonstrated, and these values are likely to increase to $\Delta R \sim 10-15\%/V$ for small signal operation in an optimised device. The device can therefore be designed to give a high value of $\Delta R/V$; however, inclusion of drive electronics may be required to meet the system requirements.

The flip-chip modulator technology (see fig. 7) is ideally suited to hybrid integration with drive electronics - possibly III-V Heterojunction Bipolar Transistor (HBT) circuits for radiation hardness - and with semiconductor detectors. GEC-Marconi have also used this approach for automatic fibre alignment using Si V-grooves. Alternatively the drive electronics may be integrated directly with the modulator, as already demonstrated by GEC-Marconi.

The uniformity across an array is directly linked to the uniformity of thickness of the epitaxial structure as this determines the cavity resonance wavelength, the exciton wavelength and the mirror peak wavelength; all of which need to be aligned accurately for optimum performance. 8x8 arrays have demonstrated uniformity of contrast of $3.3 \pm 0.25\text{dB}$, and a standard demonstrator has shown uniformity of 4nm in operating wavelength. These properties are directly related to material thicknesses. Control of layer structures at the 1% level will enable highly uniform devices to be fabricated and so reduce the number of calibration channels to a minimum.

Existing modulator device responses with bias are somewhat non-linear at higher signal levels, but modelling on optimized devices shows much improved linearity. The device will respond to arbitrarily small signals, so the dynamic range becomes more of a system than a device issue.

To obtain stable performance over long periods of time will require temperature control or compensation, because the modulator performance is temperature dependent through the temperature dependence of the position of the absorption edge of the MQW structure. As the temperature is varied this edge shifts relative to the array minimum at a rate of $\sim 0.5-0.6 \text{ nm}/^\circ\text{C}$, and so diverges from the optimum value for the design. The 3dB operating temperature range of the modulator is expected to be $\Delta T \sim 20-30 ^\circ\text{C}$ for a fixed system wavelength. Further studies of the temperature dependence, departures from linearity and configuring effects need to be carried out.

The system configuration which is presently envisaged, shown in fig. 8, shares several common features with the lithium niobate approach. The same general design of remote laser

light source and receiver with ribbon cable optic fibre interconnect is used. However, operation with the MQW reflective modulator uses the same fibre for the input to, and output from, the modulator. The optical splitter can now be located in the electronic barrack. There, each fibre connected to a modulator channel terminates in a two-way splitter; beyond this splitter one fibre path goes to the laser source, and the other to the photodiode receiver. Unlike the lithium niobate modulator, the reflective MQW modulator is insensitive to polarisation, and hence no polarisation controller is required. The choice of the number of channels in each array served by a single laser, and the decision on preamplification between the detector element and the modulator, will again be governed primarily by the power budget and the signal/noise level desired.

4.3.3 General Comments

A number of options exist for the return path to the remote readout electronics, the simplest being direct fibre connections between the modulator output and the photoreceiver. Fibres provide a nearly ideal analogue pipeline. Inherent low loss and low dispersion mean that microsecond delays can be readily implemented with no associated processing and at low cost.

Two further applications of fibre links are worth mentioning here. Firstly, if the (shaped) signal pulse length is significantly less than the beam crossing interval of 15 ns, then a set of fibre delay lines can be used together with a 'lossless' optical combiner to time-multiplex the output signals and so reduce the receiver electronics necessary. Secondly, if the modulators are implemented as dual output interferometers, one set of outputs could be used as inputs to the first level trigger while the second set of outputs could be optically delayed as described above.

The bandwidth of the optical modulators being investigated can be tens of GHz, so that the schemes outlined here for using them do not by any means exhaust their full potential, multiplexing (e.g. subcarrier frequency-division multiplexing) being clearly a very relevant issue.

Altogether, the introduction of electro-optic technology into the readout chain offers prospects not previously accessible, including possibly optical signal processing and analysis. Part of our aim would be to explore any promising features that could be of use elsewhere in the DAQ chain.

Electro-optic modulators may find useful applications in the development of a timing distribution network for LHC detectors, such as level-1 trigger acceptance and bunch crossing signals. This is presently being investigated at CERN.

4.4 Laboratory and Beam Tests

The demonstrators will be subjected to the same detailed laboratory evaluation as for the single channel devices, as described in section 4.2. In particular, any self-test implemented features and the complete calibration procedure will be thoroughly checked.

In addition, following agreements with detector groups, measurements will be performed with real detector signals injected into the modulator arrays. Beam tests can also be envisaged, with the optoelectronic devices being included in the standard detector readout.

4.5 Study of Production Processes

The proposed development programme will lead to a sound evaluation of the IOCs and to a choice of the more appropriate technology. However, the key issue of cost must be addressed in order to make this solution applicable in large quantities at LHC. Therefore, one of the objectives of our programme is a detailed study of the engineering, packaging, interconnections and production processes - that is, “productionisation” in technical jargon - that should allow these IOCs to be obtained at affordable cost. This study will be under the responsibility of Industry, with appropriate feedback on possible performance/cost trade off being provided by the HEP part of the collaboration.

5. Timescale

The timescale of the project is shown in Table 1. The activities involving industrial developments should be considered relative to the time at which funding will be assured. Interconnection, reliability and productionisation studies will proceed in parallel with the other activities.

The most significant milestones are identified as follows:

Milestone	month
Evaluation of irradiation tests on existing devices	8
Delivery of LiNbO ₃ demonstrator IOC	9
Delivery of MQW demonstrator IOC	10
Delivery of advanced system demonstrator	22
Production costing estimate	23
Concluding report with productionisation study results	24

However, it should be noted that the funding of the developments by the industrial partner (Marconi Defence Systems) in the second year of this programme is not included in the present budget request (see sect. 6.).

6. Sharing of Responsibilities

The sharing of responsibilities is shown here below:

Activity	B'ham	CERN	RAL	Marconi	EPFL	Others
Evaluation of standard devices and of IOCs		x	x			
Irradiation tests		x	x	x	x	

Tests with detectors	x	x	x	x		x
Liaison with detector groups for beam tests	x	x				
Study of preamplifier/shaper			x	x		
Integration of active functions in the IOC			x	x		
IOC design and development				x		x
Productionisation studies				x		

ACTIVITY	MONTH											
	01/02	03/04	05/06	07/08	09/10	11/12	13/14	15/16	17/18	19/20	21/22	23/24
Evaluation of standard units		█										
Specification and design of Lithium Niobate and MQW IOCs		█										
Irradiation tests		█	█									
Development of Lithium Niobate IOC		█	█									
Lab evaluation/Beam tests of Lithium Niobate IOC				█	█							
Development of MQW IOC			█	█	█							
Laboratory evaluation of MQW IOC							█	█				
Study of interconnections and reliability		█	█	█	█							
Preliminary report					█							
Productionisation studies							█	█	█	█	█	█
Development of advanced system demonstrator							█	█	█	█		
Evaluation of advanced system demonstrator											█	█
Concluding report/Production costing estimate												█

Table 1. - Timescale of the project

7. Budget Considerations

7.1 Overall Budget

The proposed programme will span over two years. The estimated budget *for the first year*, covering the developments for demonstrating the feasibility of the devices, is given below.

	KSF
LiNbO ₃ demonstrator IOC	215
MQW demonstrator IOC	215
Preamplifier/Shaper	30
Beam test equipment	40
Travel money	30
TOTAL	530

It should be noted that the cost of development by industry an advanced semiconductor subsystem demonstrator, as well as the final productionisation study, are not included in the indicated budget; a separate request for the funding of these activities will be presented at the completion of the first year of the proposed programme.

7.2 Proposed Cost Sharing

The development costs of the LiNbO₃ and MQW demonstrators given above correspond to 50% of the actual full cost, the other half being contributed by GEC-Marconi.

The UK University groups and RAL expect to contribute a total of 150 KSF to the project. The university of Lund can presently commit for 30 KSF (their contribution may be increased in the near future, subject to approval by their funding agencies). *The remaining 350 KSF would have to be provided by CERN.*

CERN has already funded the instrumentation setup that has been used for the preliminary measurements reported in this document. Birmingham is in the process of funding a similar activity.

APPENDIX A: Detector Signal Considerations

We consider here the two cases of the Transition Radiation Detector (TRD) and of the silicon preshower/tracking detector, to which the proposed technique would be applicable. Only the general features of the signals are taken into account.

a) TRD Straw tubes

In the case of the TRD straw tubes (4 mm diameter), the average energy loss of a minimum ionising particle (m.i.p.) in the standard Xe/CO₂ gas mixture is $\Delta E \approx 2$ keV. With a gas gain $G \approx 10^4$ and an effective integration time $t \approx 30$ ns, the collected charge is $Q_{\text{mip}} \approx 10$ fC.

The lowest threshold, used for tracking, would be set at $\delta E \approx 0.2$ keV. Therefore, the smallest charge to be detected would be $q \approx 1$ fC. The largest signal, corresponding the energy deposition by TR X-rays, would be $Q \approx 50$ fC. Terminating the straw tube in its characteristic impedance of approximately 270 Ohm may further reduce the signal amplitude.

For the TRD, an 8-bit equivalent dynamic range is adequate. The overall integral linearity is required to be within $\approx 1\%$ in this range.

b) Silicon detectors

The thickness of the depletion layer in Si detectors is usually ≈ 300 microns. A m.i.p. at normal incidence has a skewed energy-deposit distribution with most probable energy deposit of ≈ 78 keV corresponding to $\approx 25,000$ electron-hole pairs. The charge collection time is ≈ 20 -30 ns. This results in a minimum detectable charge $q \approx 2$ fC.

Similar considerations apply to gas avalanche chambers and GaAs detectors. In general, a low-noise ($q_n < 1,000$ electrons or 0.16 fC) preamplifier, directly connected to the detector, is required to achieve a good signal/noise ratio. This would further be improved by a suitable pulse shaping.

References

- [1] "Integrated High-Rate Transition Radiation Detector and Tracking Chamber for the LHC", *CERN/DRDC/90-38, DRDC/P8*, August 1990.
- [2] "A Proposal to Study a Tracking/Preshower Detector for the LHC", *CERN/DRDC/90-27, DRDC/P3*, August 1990.
- [3] "Development of High Resolution Si Strip Detectors for Experiments at High Luminosity at the LHC", *CERN/DRDC/91-10, DRDC/P26*, March 1991.
- [4] "Proposal to Develop GaAs Detectors for Physics at the LHC", *CERN/DRDC/90-58, DRDC/P13*, October 1990.

Other tracking detectors such as Gas Avalanche Microstrip Detectors and the Gaseous Pixel Chamber are described in *Proceedings of the LHC Workshop (Aachen), CERN 90-10*, October 1990

- [5] B.E. Kincaid, "Transmission Measurements on GaAlAs Integrated Optic Waveguides Exposed to Ionising Radiation", *Appl. Opt.* 25,1736-1737, 1986.
- [6] B. Leskovar, "Radiation Effects on Optical Data Transmission Systems", *IEEE Trans. Nucl. Sci.* 36, 543-551, 1989.
- [7] A. Donaldson, "Candidate Materials and Technologies for Integrated Optics: Fast and Efficient Electro-Optic Modulation", *J. Phys. D: Appl. Phys.* 24, 785-802, 1991
- [8] A.Y. Cho and A.M. Glass, "Photonic Materials and Processing", *AT&T Techn. Journal*, 77-91, Nov./Dec 1990
- [9] C. Da Via, I. Kenyon and G. Stefanini, "Measurements on a GEC-Marconi Electro-Optic Modulator", *CERN-ECP*, in preparation
- [10] T. Tsang, V. Radeka, T. Srinivasan-Rao and W.J. Willis, "A Study of Electro-Optical Modulators for Transfer of Detector Signals by Optical Fibers", *BNL-45393*, Oct. 1990
- [11] A. C. O'Donnell, "1x16 Lithium Niobate Optical Switch Matrix with Integral TTL-compatible Drive Electronics", *Proceedings of the Topical Meeting on Integrated Photonic Research, Monterey, OSA Tech. Digest Series 8*, 77-78, 1990.

[12] A.J. Moseley et al., "Low Voltage InGaAs/InP Multiple Quantum Well Reflective Fabry-Perot Modulator", *Electronics Letters* 26(13), 913-915, 1990.

Figure captions

- Fig. 1 Structure of a single channel LiNbO₃ Mach-Zehnder intensity modulator.
- Fig. 2 (a) Transfer characteristics of a LiNbO₃ intensity modulator.
Measurements done at receiver photocurrent $I_{\max} \hat{=} 0.5$ mA.
Extinction ratio = $10 \text{ Log } (I_{\max}/I_{\min}) \hat{=} 18$ dB
- Fig. 2 (b) Linearity of LiNbO₃ intensity modulator.
Modulator biased at quadrature point ($V_b = 0.7$ V), $I_{\max} \hat{=} 0.5$ mA
Input : rectangular voltage pulse.
Photodetector output: charge sensitive preamp, amplifier shaping time constants 20 ns.
Overall equivalent input noise $\hat{=} 1$ mV (baseline fluctuations from laser excess noise).
Dynamic range $\hat{=} 500:1$ for integral non-linearity ² 1%.
- Fig. 3 Optical test bench for LiNbO₃ intensity modulator.
Input fibre pigtail: monomode, polarisation-preserving.
- Fig. 4 Structure of MQW reflective intensity modulator.
- Fig. 5 Schematic of LiNbO₃ modulator array.
For clarity only 8 channels are shown.
- Fig. 6 Schematic of Integrated Optical Circuit (IOC) in LiNbO₃ technology.
For clarity only 4 channels are shown.
- Fig. 7 Structure of MQW reflective modulator with flip-chip technology.
- Fig. 8 Schematic of Integrated Optical Circuit (IOC) in MQW semiconductor technology.
For clarity only 4 channels are shown.

Modulator Transfer Characteristics

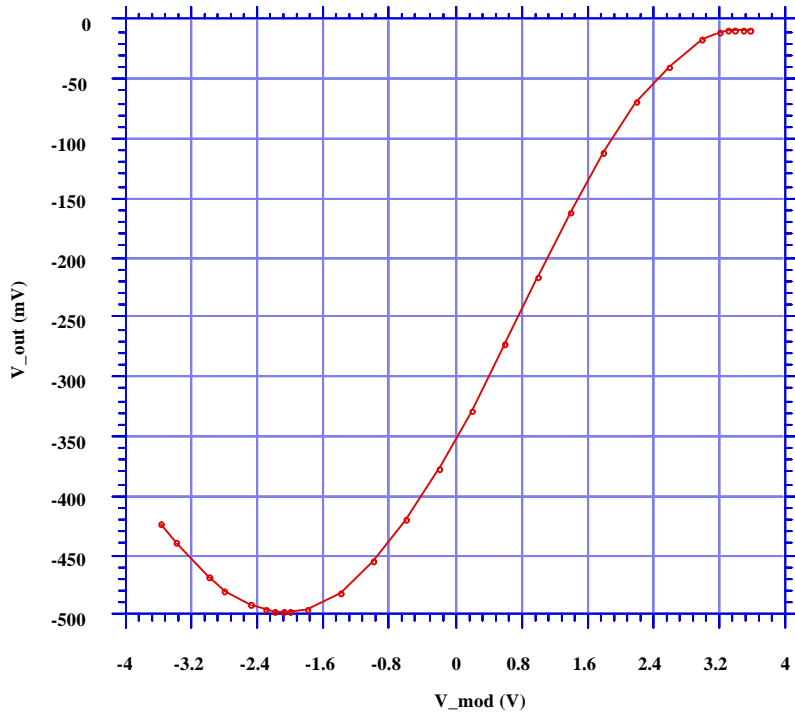

Fig. 2 (a)

Modulator Linearity Curve

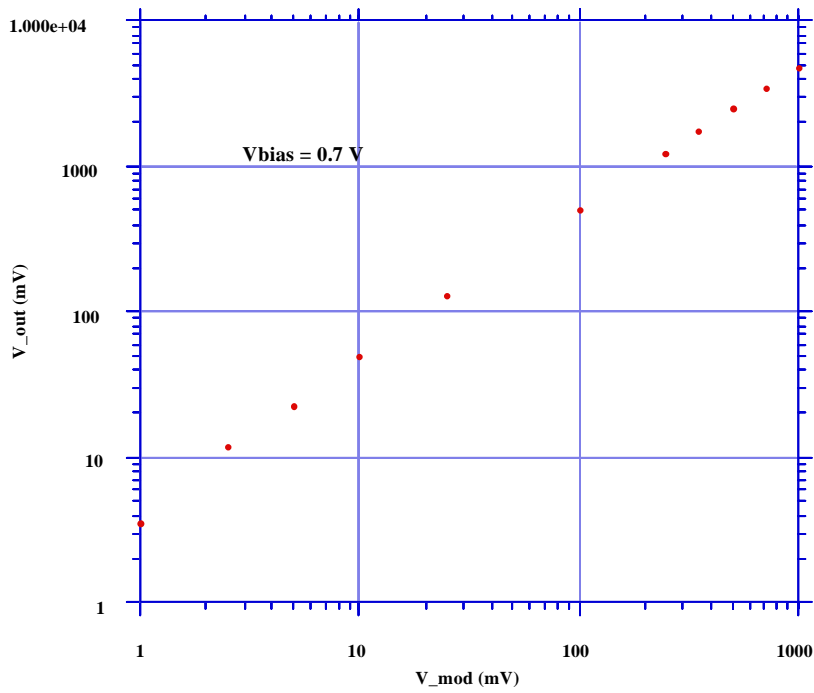
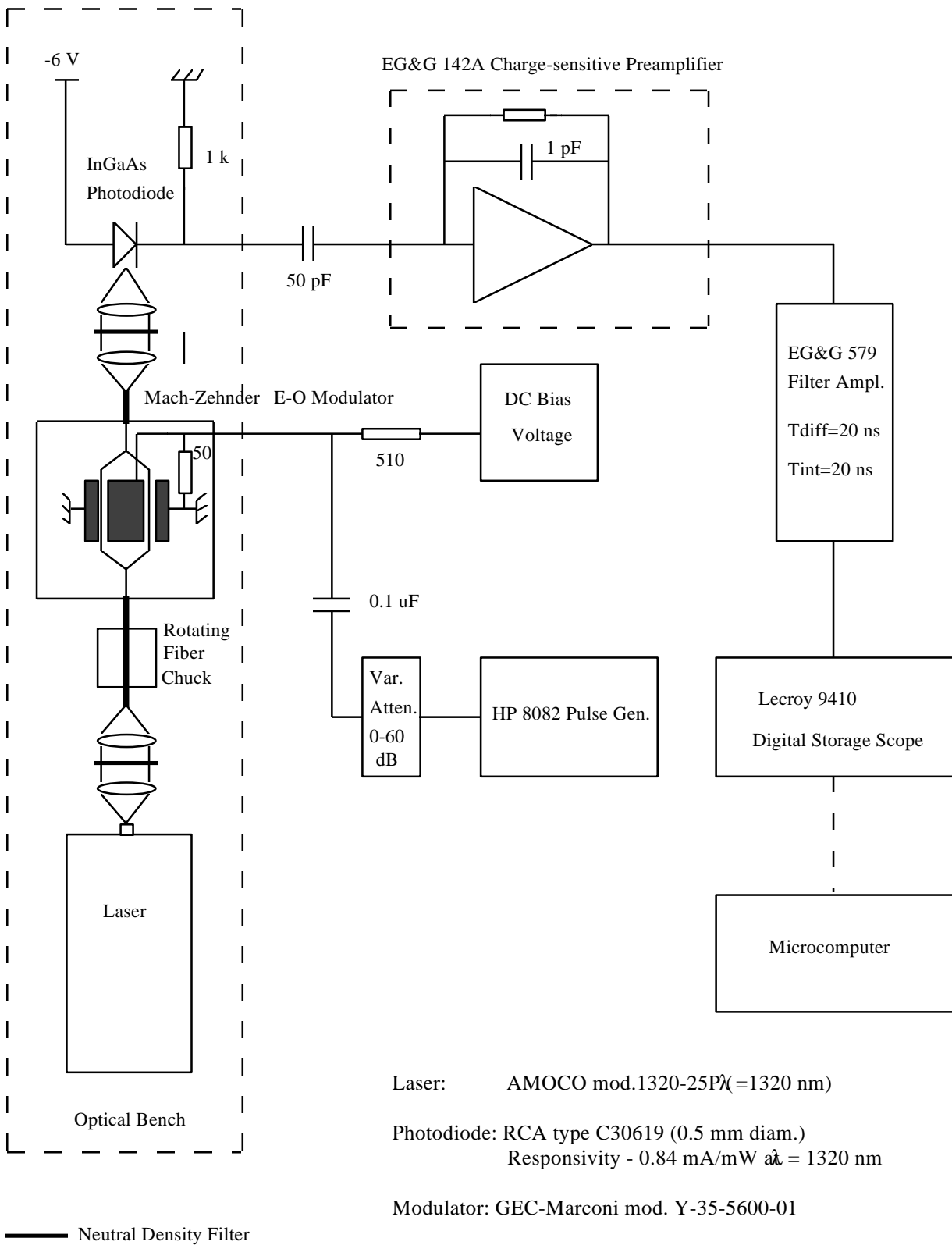

Fig. 2 (b)



Experimental Setup for Linearity and Noise Measurements

Fig. 3