

Large Hadron Collider Project

LHC Project Report 35

EVALUATION OF IMPACT FROM RIPPLE AND TRANSIENT PHENOMENA IN THE LHC DIPOLE STRINGS

K. Dahlerup-Petersen and F. Schmidt

Abstract

Based on measurements of the A.C. electrical characteristics of prototype magnets, synthesised computer models of the principal, individual, superconducting magnetic elements of the Large Hadron Collider have been elaborated. The models constitute the basic elements for the determination of the transfer functions of the magnet chains. This tool provides the possibility to evaluate the resonance spectrum of the chains and to determine the needs for additional damping. Results of the analysis of transmission line effects in the LHC main dipole chains are presented. In particular, data from ripple calculations and ramping studies are discussed. Computer simulations of the quench protection circuit provide information about the transient phenomena occurring in the dipole chains during normal operation of the fast de-excitation switches and under abnormal conditions.

Administrative Secretariat
LHC Division
CERN
CH-1211 Geneva 23
Switzerland

Geneva, June 1996

1 Introduction

At this early stage of the LHC project, simulation appears as the only possible method to obtain vital information about the dynamic performance of long chains of magnets. For operational purposes it is mandatory to determine the resonance frequencies of the transmission lines. More subtle problems, related to low frequency tune modulation due to power supply ripple, reducing the dynamic aperture in presence of strong nonlinear fields, must be studied. The possible need for and consequences of individual damping, choice of ramping procedure, location of the earthing point and the location, performance and operation of the fast energy extraction systems are other important issues, for which solutions cannot wait for the availability of a complete octant of magnets. Fortunately, today's powerful simulators allow handling of electrical equivalent circuits containing thousands of components. For the present study the SABER simulator was used. All presented data are related to the dipole chain of one LHC octant, containing 212 first-generation dipoles.

2 Electrical dipole model

For the measurements of the frequency dependence down to the mHz range of the electrical characteristics of the dipoles, a transfer function analyser was combined with a frequency generator. Both Closed- and Open-ended A.C. characteristics measurements were made on a prototype dipole.

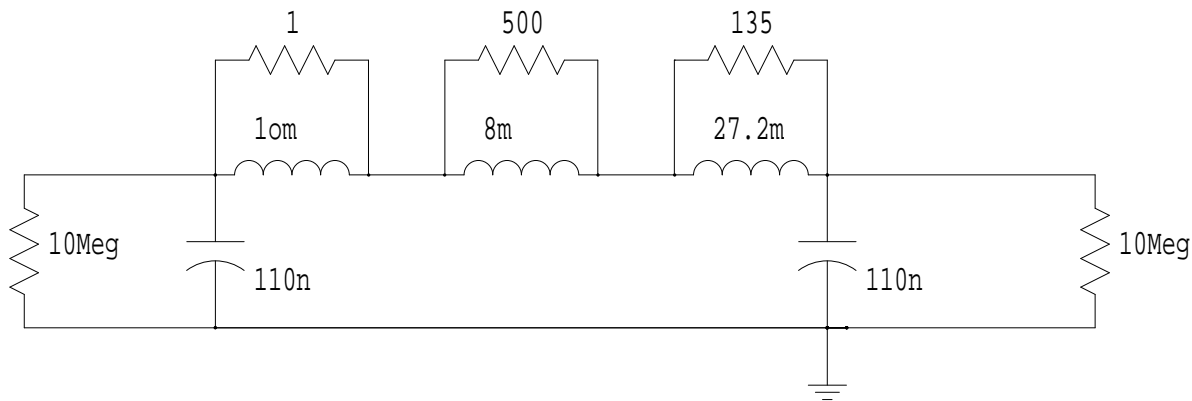

Figure 1: Best First Order Fit for an A.C. electrical Model

Following the theoretical derivations in Ref. [1, 2, 3] a synthesised electrical model was concocted and fitted to the measured data. The total dipole inductance, taken as the figure obtained from a very low frequency spot measurement, was divided into three parts in order to take into account the effect of the inter-strand and the inter-filament eddy currents. The total capacitance to ground was divided into two identical lumped components and placed in either end of the model circuit. The measurements are compared with the first order modelling in Fig. 1. The measurements were done with *closed* and *open* circuitry (earthed measurement) as described in Ref.[4]. To achieve a satisfactory agreement the simple first order model of Fig. 1 had to be extended to second order. This becomes apparent when the detail of the resonance zone at about 5 kHz and above were studied: the curves of the first order model start to deviate above 10 kHz and the measurements indicate that there is a secondary maximum (the data points cross over) which requires at least a second order system.

Measurement and Model of the Amplitude of Impedance of the Ansaldo III LHC Dipole Magnet

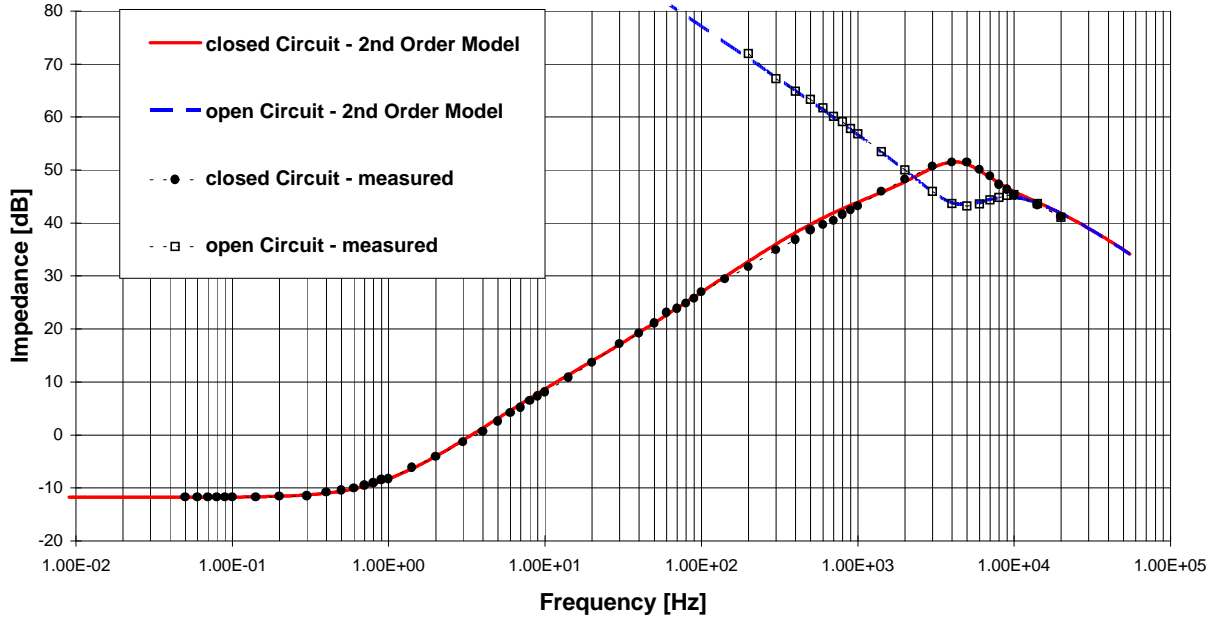

Figure 2: Amplitude of Impedance

However, for a modelling of a full octant of the LHC comprised of 212 dipoles the first order model is fully sufficient as the frequency of the first resonance is reduced to roughly 12 Hz. The full octant had a spectrum of unacceptably large resonances. An additional damping with a resistor in parallel with the inductance of some 20 Ω reduced these resonances appreciably without causing too much trouble with respect to tracking precision or overheating of the resistor.

3 Ripple analysis

The basic power circuit for the ripple, ramping and transient studies is shown in Fig. 3, each dipole being represented by its synthesised model.

The closed-circuit, total chain, impedance spectrum of a complete octant (Fig. 4) is the starting point for any current ripple calculation. The shift towards higher frequencies for the mid-point earthed system will double the resonance frequencies for this configuration, compared to the end-point earthed circuit. The attenuating effect of the additional damping resistance is more important with mid-point earthing. The frequency dependent total ripple current through the converter as function of the output voltage ripple (Fig. 5) strongly depends on the earthing and damping. The significant reduction of the total current ripple in the resonance region and above in the case of mid-point earthing is a first result. The observed attenuation in the resonance region with increased damping is expected. For frequencies above 200 Hz, however, the total ripple current will rise with increased damping. This rise does not lead to higher ripple in the dipoles, but is entirely caused by an increase in the current through the damping resistors.

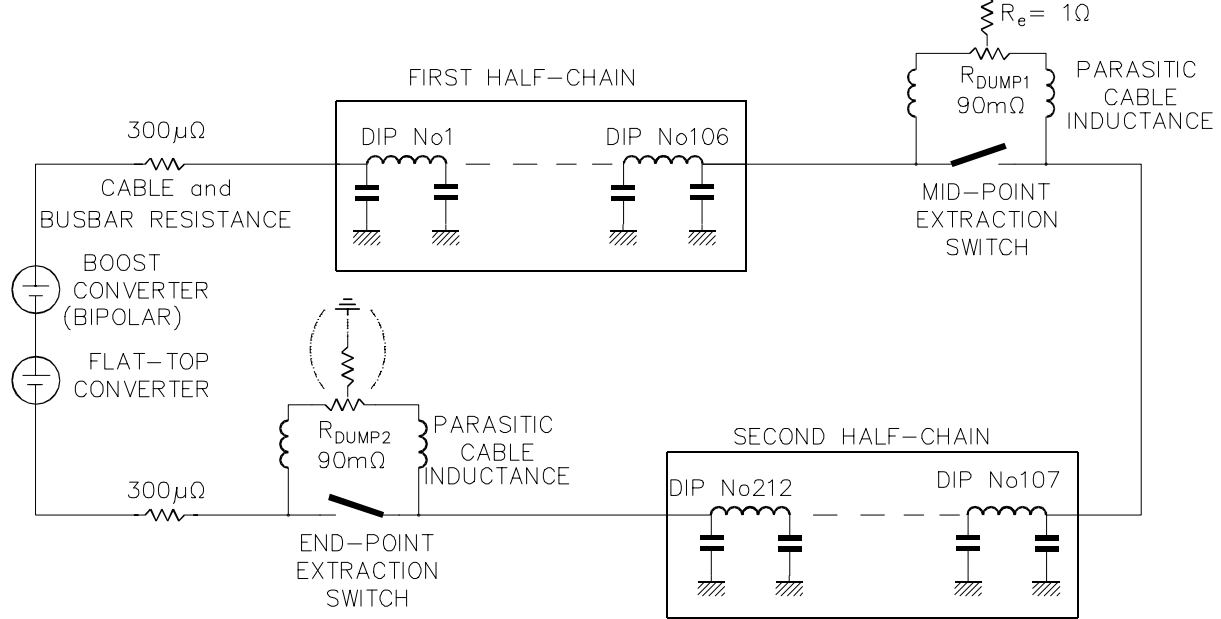

Figure 3: Template form of the power circuit.

Four principal configurations were systematically considered in each study: earthing at the centre of the mid-point or the centre of the end-point dump resistor, natural damping or additional damping with 20 Ω/dipole.

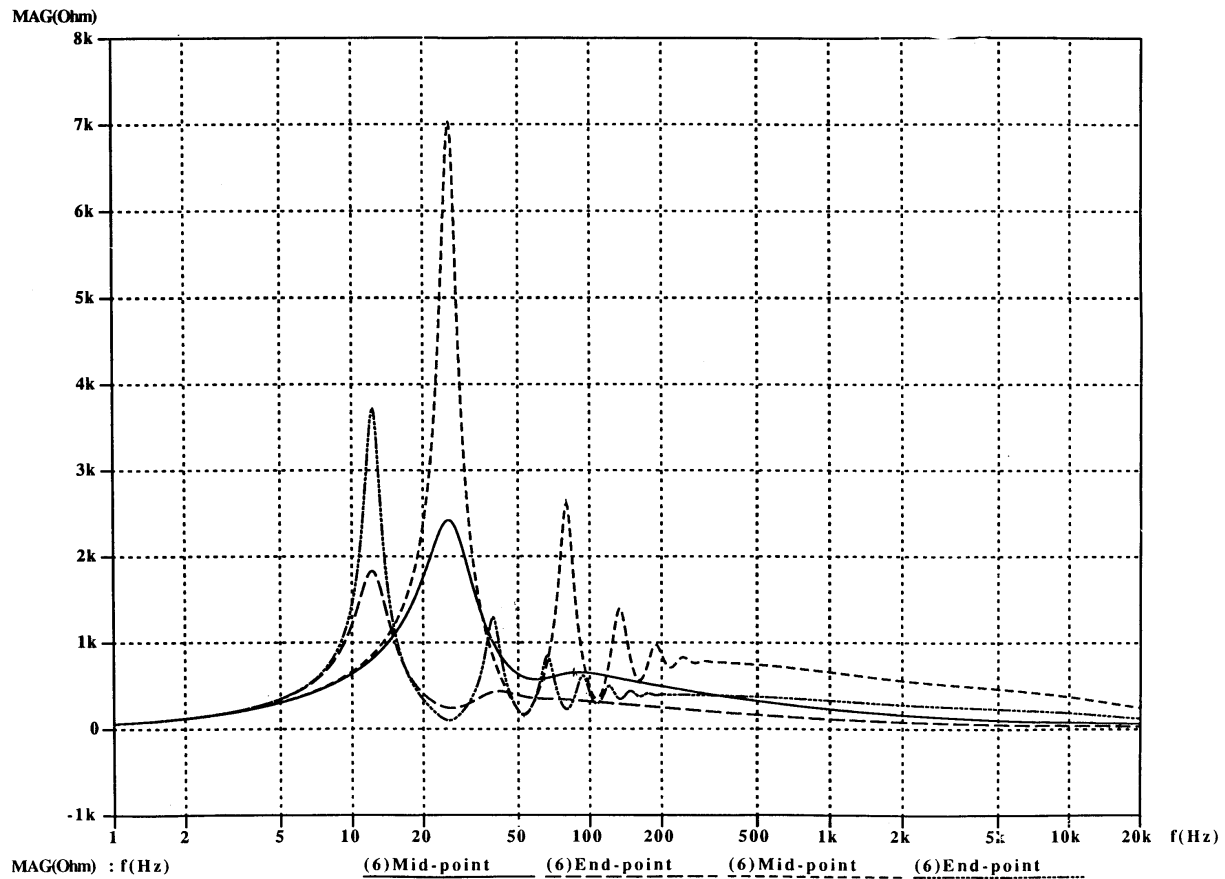

Figure 4: Total load impedance w.r.t. frequency.

The current ripple in the coils of the individual dipoles along the string give a precise picture of the local perturbations. For very low frequencies all the dipoles feature the same ripple. Differences begin to appear around 2-5 Hz and the current amplitudes follow a typical pattern, in which odd numbered resonances provide ripple suppression in the middle of the chain, whereas even numbered resonances give ripple suppression at the quarter and three-quarters points. This pattern is true for both mid- and end-point earthing with the difference, that in the former case the picture is valid for one half-octant. For frequencies above 1 kHz the ripple currents drop to zero after just a few magnets from the beginning of the chain. As the higher-frequency current ripple of the first dipoles in the string is practically independent of the damping, the significant increase in the total ripple with increased damping can only be attributed to a rise in the damping resistor currents. Calculations show that it is the damping resistors of the first few magnets which accounts for this increase. For frequencies below 10 Hz the damping resistor currents are identical throughout the chain. The most favourable ripple conditions are obtained with the mid-earthed configuration. For a typical 500 mV converter voltage ripple, the corresponding current ripple is here 0.06 ppm at 600 Hz (12-pulse, thyristor converter).

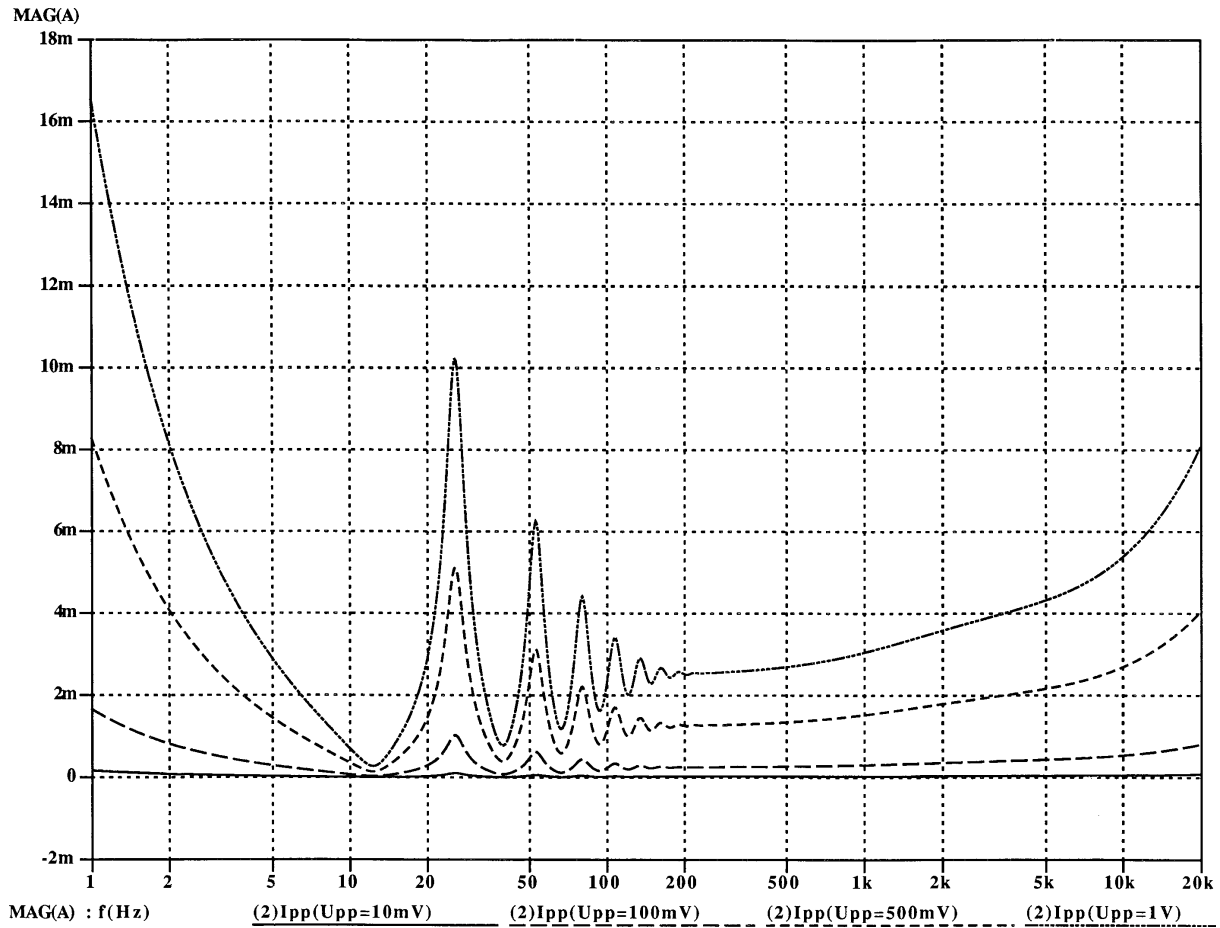

Figure 5: Total current ripple as function of frequency.

4 Ramping studies

The transmission line effects related to various application profiles of the ramping voltage were analysed in order to determine the instantaneous differences in the currents between the individual dipoles. In case of a simple step function the delay for the voltage

wave to reach a given dipole in the chain is independent of the amplitude of the step and of the damping, but doubles in case of end-point earthing. The oscillating behaviour of the current rise is presented in Fig. 6. The dipoles, for which the current is in the lead change with those, for which the current is lagging behind, until full attenuation of the oscillation. The periodicity is 9.5 ms.

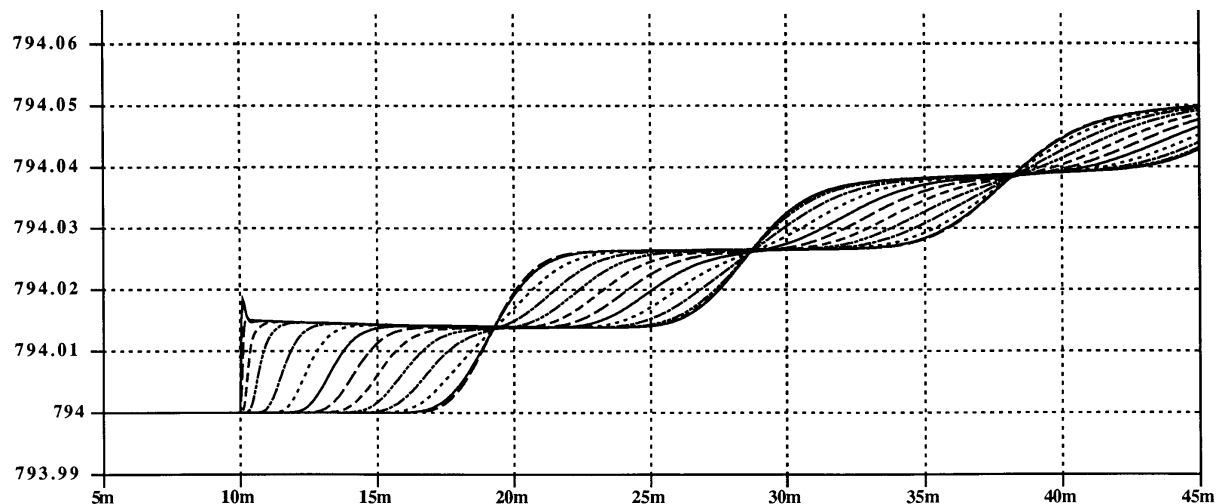

Figure 6: Dipole currents during start of a current ramp.

Defining the current error as the difference between the current in a given magnet and the current in the first dipole of the chain, the relationship between the error and the amplitude of the voltage step is linear. However, the error depends on the damping and the location of the earthing point. The attenuation of the voltage oscillations by additional damping will cause smoother transitions of the current oscillation, resulting in reduced errors. Typical error values are: End-point earthing: 37 ppm (no damping), 23 ppm (20 Ω /dipole), Mid-point earthing: 18 ppm (no damping), 11 ppm (20 Ω /dipole). Such figures are unacceptably high. However, considerable improvements can be achieved by replacing the voltage step by a voltage ramp, providing a parabolic current rise. In this case the current errors are only determined by the capacitive and resistive conduction to ground. After a short oscillation the capacitive current is constant during the voltage ramp, proportional to dU/dt , and will disappear at the end of this. The resistive part, proportional to the applied voltage, is predominant. The total maximum errors are now reduced to 0.45 ppm for end-earthing and 0.1 ppm for mid-earthing. The current errors are in this case independent of the damping. More complex voltage profiles (e.g. including parabolic beginning and end of the ramp) will only give a very marginal improvement of the error.

5 Transient effects

This part of the analysis is devoted to the dynamic phenomena occurring during the fast extraction of the stored magnetic energy. By simultaneous opening of the two switches, voltage waves of opposite polarity to ground will penetrate into each half-chain from either end, with amplitudes corresponding to half the voltage rise over the dump resistors. The transmission line induced voltage oscillations (104 Hz) are particularly violent in the region between magnet no. 20 and 40 from either end of each half-chain, as the potential here varies from zero to almost full amplitude, but at no point the oscillations

result in voltage overshoots. Because of the intrinsic damping the oscillations die out in less than ten periods of 9.5 ms. For the dipoles adjacent to the centre the voltage rise is small and occurs with a delay of 2.5 ms. By additional damping with 50-20 Ω /magnet the oscillation is efficiently and rapidly attenuated. This constitutes the most important argument in favour of applying additional damping. As long as the earthing point is placed at the centre of one of the dump resistors, there is no difference between mid- and end-earthing. However, traditional earthing of one of the converter terminals results in catastrophic voltage levels to ground as the voltage waves in the two half-chains will superimpose, giving amplitudes as high as 1620 V at the centre of the octant. Additional damping will only slightly improve this situation. Because of the symmetry, both the resistive and the capacitive currents to ground due to switch opening will cancel inside each half-chain, this being true for both mid- and end-earthing (but not for terminal earthing). Consequently, the resulting earth current flowing back into the power circuit through the earthing resistor of the converter is zero. The earth currents, caused by a sudden fall-out of the converter, will cancel only in the case of mid-point earthing. Abnormal cases, where one of the extraction switches are stuck in its closed position, were simulated. Although the oscillations change form (double wavelength and delay), the maximum voltage to ground remains unchanged. Further consequences are a slower attenuation of the oscillations and the risk of overheating of the dump resistor, which must absorb almost the double energy.

6 Conclusion

For the elaboration of the LHC dipole model, information from both open- and closed circuit TFA measurements are required. A circuit of at least second order is needed to obtain a precise description of an individual magnet, whereas a first order circuit is sufficient as basic element for the study of the static and dynamic effects in the chains. The transmission line analysis resulted in an abundant harvest of useful information and recommendations, of which the principal are: 1) current ripple values are well within acceptable limits even at the resonance points, 2) linear ramping voltages are necessary, but also sufficient for reducing instantaneous current errors between dipoles, 3) earthing at the mid-point of the central dump resistor provides significant advantages in all aspects, 4) damping with at least 50 Ω /dipole is recommended, 5) accidental blockage of one extraction switch does not cause any risk of damage by over-voltage.

7 Acknowledgements

The authors wish to express their appreciation of the assistance of J-M. Asanza, CEDEX, Madrid during the simulation work.

References

- [1] R. Shafer, Fermilab, TM-991, 1620.000, (1980).
- [2] R. Bacher et al., DESY HERA 90-16, (1990).
- [3] P. Burla et al., AIP Conference Proceedings **326**, (1994).
- [4] K. Dahlerup-Petersen and F. Schmidt, LHC Project Note 11.