

EUROPEAN ORGANIZATION FOR NUCLEAR RESEARCH  
European Laboratory for Particle Physics*Large Hadron Collider Project***LHC Project Report 27****SUPERCONDUCTING SEXTUPOLE CORRECTOR MAGNET FOR THE LHC MAIN DIPOLES**J. Salminen, A. Ijspeert\*  
A. Puntambekar\*\***Abstract**

Each LHC main dipole will be equipped with small sextupole corrector magnets with a field strength of  $1970 \text{ x}^2 \text{ T/m}^2$  and a magnetic length of 100 mm designed to correct the sextupole field errors. The paper presents a cosine- $\theta$  type of design where much emphasis has been put on the cost reduction because these magnets have to be made in large series of some 2500 pieces. We describe the design of a two-layer coil which can be wound automatically. The winding starts in the middle of the wire with the only joggle, the layer jump, which is housed in a corresponding groove in the end of the central island. The two layers are wound simultaneously turning in opposite directions to find their position without the need of local tooling. The coil ends are closely packed and need no end spacers. The 18 pole perturbation introduced by the ends is corrected by the position of the coil block in the straight part. The yoke is made of iron laminations of the "scissors type" which transmit the pre-stress from the outer aluminium shrink ring to the coil. This allows the iron to be close to the coil for field enhancement and also boosts the pre-stress in the coil due to the cool down contractions. The paper describes the experience with the magnet construction and gives the first test results.

\*LHC Division, ICP Group

\*\*CAT, Indore, India

EPAC 96, Sitges, Spain, June 1996

CERN  
CH - 1211 Geneva 23  
Switzerland

Geneva, 15/07/96

# SUPERCONDUCTING SEXTUPOLE CORRECTOR MAGNET FOR THE LHC MAIN DIPOLES

Jukka Salminen, Albert Ijspeert, LHC Division, CERN, Geneva, Switzerland  
Avinash Puntambekar, CAT, Indore, India

## Abstract

Each LHC main dipole will be equipped with small sextupole corrector magnets with a field strength of  $1970 \text{ x}^2 \text{ T/m}^2$  and a magnetic length of 100 mm designed to correct the sextupole field errors. The paper presents a cosine- $\theta$  type of design where much emphasis has been put on the cost reduction because these magnets have to be made in a large series of some 2500 pieces. We describe the design of a two layer coil which can be wound automatically. The winding starts in the middle of the wire with the only joggle, the layer jump, which is housed in a corresponding groove in the end of the central island. The two layers are wound simultaneously turning in opposite directions to find their position without the need of local tooling. The coil ends are closely packed and need no end spacers. The 18 pole perturbation introduced by the ends is corrected by the position of the coil block in the straight part. The yoke is made of iron laminations of the "Scissors type" which transmit the pre-stress from the outer aluminium shrink ring to the coil. This allows the iron to be close to the coil for field enhancement and also boosts the pre-stress in the coil due to the cool down contractions. The paper describes the experience with the magnet construction and gives the first test results.

## 1 INTRODUCTION

### 1.1 General

In the LHC ring each bore of the main bending dipole is equipped with a superconducting sextupole (MCS) and decapole (MCD) corrector magnet to correct systematic sextupole and decapole field errors in the dipole field. Sextupole correctors are placed at one end of the dipoles and decapoles at the opposite end. In the first generation sextupole corrector design, coils were wound around a copper central island in eight layers each consisting of fourteen turns [1]. This coil design proved to be laborious and expensive to manufacture, since after each turn the cable must be twisted to be able to jump to the next turn, and after each layer to do a layer jump. During the winding each turn must be clamped by special tooling to prevent unwinding of the coil. The new design drastically reduces the time to

make a magnet. In this paper will be described only the design and the manufacturing of the sextupole magnet however similar design principles will be used for the decapole and octupole magnets. Six of this type of sextupole and decapole and four octupole magnets will be built at CERN by beginning of April 1997.

### 1.2 Design Criteria

The design criteria of the magnets are given by the beam dynamics and the available space in the dipole ends. The main parameters are given in the Table 1. In the LHC ring the corrector power supplies will be of 600A type.

Nominal strength	1970 $\text{x}^2 \text{ T/m}^2$
Magnetic / Overall length	104 / 150 mm
Nominal current	625 A
Peak field in the coil 3D	2.12 T
Self inductance	0.672 mH
Inner / Outer diameter of the coil	58 / 61 mm
Inner / Outer diameter of the yoke	66 / 90 mm
Inner / Outer diameter of shrink ring	89.88 / 100 mm
Cable dimensions bare	1.13x0.606 $\text{mm}^2$
Cu/Sc ratio	1.6
Insulation thickness (PVA)	0.06 mm
Turns per coil	2x13
Working temperature	1.9 K
% on the load line 1.9 / 4.2 K	62.9 / 47.5

Table 1. Magnet parameters

## 2 MAGNETIC DESIGN

### 2.1 General

The magnetic design aimed for an economic two layer coil. In the design a combination of 2D and 3D modelling has been used. 3D models have been created using the ROXIE program, which uses Biot-Savart on the line currents [2]. The surrounding iron yoke can only be modelled with linear or infinite permeability. The induction of the iron remains well below the saturation level up to nominal operation level, which was checked with the POISSON program in 2D. ROXIE is not able to calculate 3D peak fields in a coil surrounded by iron, the 2D peak field in the coil is calculated with and without iron and the same ratio is assumed to be valid in 3D.

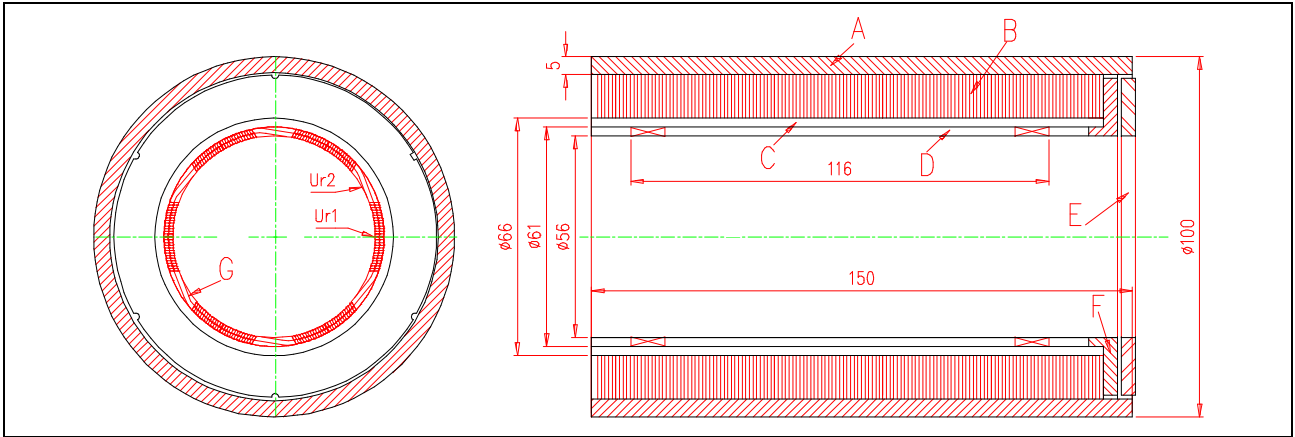

Figure 1. MCS magnet A: Shrinking ring B: Scissor laminations C: Glass fibre bandage D: Coils E: End cover F: End flange for the connections G: Layer jump in one end of the central island

## 2.2 Coil optimisation

By bringing the surrounding yoke close to the coils for field enhancement, it was possible to reach the required field strength by using a two layer coil. The iron boosts the field by 48.5 %. The coil ends are designed without end spacers to allow for automatic winding. The eighteen pole perturbation induced by the coil ends was compensated by the position of the coil block in the straight part (Table 2). An existing wire was chosen because it's availability. In the LHC ring 154 of these magnets are connected in series and in case of a quench, most of the energy of the 153 other magnets is absorbed in the quenching magnet. In order to survive a quench, for the final design the amount of the copper in the wire will be increased by 40 %, i.e. the Cu/Sc ratio increases from 1.6 to 2.25 [3].

B3 [Tm]	B9/ B3 [ $\times 10^{-4}$ ]	B15/ B3 [ $\times 10^{-4}$ ]
-0.0206249	0.01978	0.000417

Table 2. Integrated harmonics at radius of 10 mm

## 3 MECHANICAL DESIGN

### 3.1 Central island material

Glass fibre reinforced epoxy (G11) was chosen for central islands and end spacers material, since it is integrated contraction factor  $260 \times 10^{-5}$ , in the longitudinal direction between 293 and 4.2 K, is close to that of the cables  $295 \times 10^{-5}$ . In addition to which no ground insulation is needed. The end filling pieces and central islands were machined from tubes of this material.

### 3.2 Scissor laminations

The iron yoke is composed of so called scissor laminations, which transmit the pre-stress from the outer aluminium shrink ring into the coils [4]. Two slightly eccentric laminations, which press from opposite directions on the glass fibre bandage around the coils, form a pair

of “scissors”. Over the length of the magnet, successive pairs of laminations are rotated by  $60^\circ$ . As the lamination thickness is 1 mm, every 6 mm pressure is applied in the same angular position.

### 3.3 FEM-model

A 2D FEM-model has been created, to define stresses in the structure. A  $30^\circ$  sector of the magnet has been modelled using the ANSYS code. The eccentric contact of the scissor laminations to the aluminium shrink ring and the fibre glass bandage has been simulated by using contact elements. Table 5 presents the calculated azimuthal stresses in the coil and in the aluminium cylinder during different load steps.

	293 K	4.2 K	4.2 K (1000A)
$\sigma$ coil max.	-21	-27	-22
$\sigma$ coil min.	-49	-68	-74
$\sigma$ cyl max.	56	107	108
$\sigma$ cyl min.	-7	21	28
Rad disp Ur1	-0.020	-0.139	-0.133
Rad disp Ur2	-0.0334	-0.168	-0.166

Table 3. Azim. stresses in coil and shrink ring [MPa] and radial displacements of the coil [mm] (Fig 1). Radial interference between yoke and shrink ring is 0.06 mm

## 4 FABRICATION

### 4.1 Coil winding

The two layer coil (double pancake) design allows to start winding in the middle of the coil with the only joggle, the layer jump, which has been housed in a groove in the end of the central island. The two layers are wound simultaneously in opposite directions to find their position automatically not needing the clamps normally used to keep the wire in it's plane. The wire is continuously wetted during the winding process by epoxy (Fig. 2). To produce compact coils a constant winding tension of 35 MPa was maintained in the metal

cross section of the cable. Although the wire is thin, when bent over the end of the central post, it has a tendency to bend away from the central post in the straight part, due to its bending stiffness. If the wires are then pushed towards the central island after the whole coil is wound, most of the winding tension will be lost. The situation can be improved, by counter bending the wire around a small pulley, which deforms the wire so that it naturally pushes itself towards the central post. In addition to counter bending, before winding the central island is pre-compressed in the longitudinal direction by 0.1 mm. This is done by applying a load of 350 N the ends, and then locking the central island in place by screws. After the winding the locking screws are loosened so that the pre-stressed central island and the surrounding coil find an equilibrium. After the winding the end fillers are positioned and the coil is clamped in the curing mould, which is doweled through the central island on the winding mandrel. Finally the coil is heated in the oven in order to cure the epoxy. Winding and impregnation take approximately two hours per coil using a simple hand driven machine.

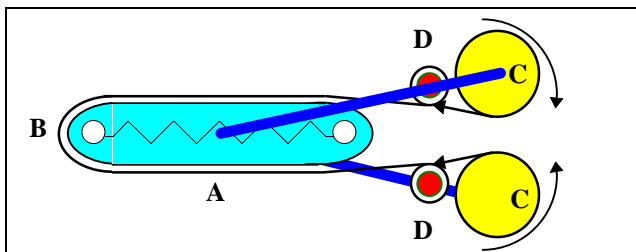

Figure 2. Winding A: Pre-compressed central island B: Layer jump C: Wire reels D: Counter bending pulleys

#### 4.2 Assembly of the magnet

The impregnated coils are positioned by dowel pins around an assembly mandrel and a glass fibre-epoxy end flange is placed at one end of the coils for the series connections. A prepreg glass fibre cloth is wrapped around the coils whereupon it is clamped and cured in an oven. After turning the bandage, holes are drilled in the positions of the dowel pins, and these pins are pushed into the hollow mandrel which is then pulled out. The series connections are made by soldering the wires side by side in grooves on the end flange over a length of 35 mm. The connections are kept in place by a glass fibre cover plate which is screwed on the end flange. The yoke laminations are assembled around the glass fibre bandage as described in the section 3. To facilitate the slipping on of the heated aluminium shrink ring over the laminations, a slightly conical Teflon hat is mounted at the end of the magnet.

### 5 TEST RESULTS

The training test of the magnet was done at 4.2 K in Madrid, by CEDEX. The first quench of the magnet was

at 734 A which is well above the nominal operation level (Fig. 3). After a heat cycle to room temperature the magnet showed very little re-training i.e. the first quench occurred at 934 A. The current was measured by clamp meters around the bus bars with an accuracy of  $\pm 20$  A. Voltage taps were installed over the poles in order to record the quench voltages. Also the current decay was measured in order to calculate the MIIT's and hence define the hot spot temperatures which proved to be at maximum around 130 K.

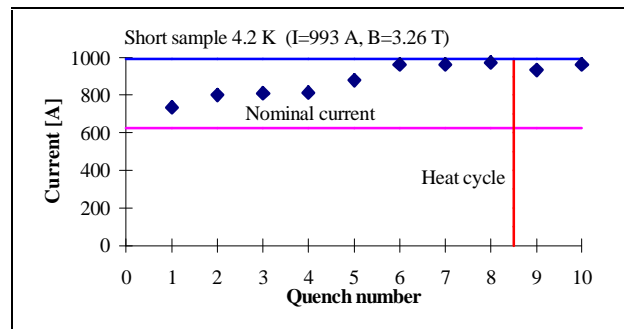

Figure 3. Training of the magnet at 4.2 K.

### 6 CONCLUSIONS

A second generation cosine- $\theta$  type of superconducting sextupole corrector magnet (MCS) has been designed and built at CERN. A training test has been done at 4.2 K by CEDEX. By using scissor laminations, it has been possible to bring the iron close to the coils for maximum field enhancement. Since the iron boosts the field by 49%, the required field strength of 0.197 T at 10 mm radius, is obtained by two layer coil. The aim of the two layer coil design has been to allow for an easy automatization of the winding process.

### ACKNOWLEDGEMENT

The authors acknowledge J. Perez and J. Mazet who carried out numerous winding tests and built the magnet as well as D. Regin who shared his experience. We also acknowledge the help of our colleagues in CAT, especially M. Karmakar and R. Adbol. Finally we would like to thank L. García-Tabarés and his team in CEDEX for testing the magnet.

### REFERENCES

- [1] D. Bayham, R. Coombs, A. Ijspeert, R. Perin, "Design of Superconducting Corrector Magnets for LHC", IEEE Trans. on Magnetics pp. 1823-1826, Vol 30, No 4, July 1994
- [2] S. Russenschuck, "A computer program for the Design of the Superconducting Accelerator Magnet", Proc. of ACES'95, Monterey, CA, USA
- [3] D. Hagedorn, F. Rodrigues-Mateos, R. Schmidt, "Protection of LHC Superconducting Corrector and Insertion Magnets", In this conference
- [4] A. Ijspeert, J. Salminen, "Superconducting Coil Compression by Scissors Laminations", In this conference