



CERN LIBRARIES, GENEVA



B00005434

CERN/ISC 93-27
ISC/P 54
July 27th, 1993,

Proposal to the ISOLDE Experiment Committee

Mass measurement of very short half-lived nuclei

Collaboration :

G. Audi⁸, G. Bollen⁶, C. Borcea², H. Doubre⁸, D. Guillemaud-Mueller⁹, P. G. Hansen¹, B. Jonson⁵, H.-J. Kluge⁶, G. Lebé³, R. B. Moore⁷, A. C. Mueller⁹, G. Nyman⁵, M. de Saint Simon⁸, C. Thibault⁸, H. Wollnik⁴

1. Aarhus University, Institute of Physics and Astronomy
2. Bucharest, Institute for Atomic Physics
3. CERN, PPE division, Geneva
- 4 Giessen University, Physikalisches Institut
- 5 Göteborg, Chalmers University of Technology, Department of Physics
- 6 Mainz University, Institut für Physik
- 7 McGill University, Montreal, Foster radiation Laboratory
- 8 Orsay, Centre de Spectrométrie Nucléaire et de Spectrométrie de Masse (CNRS-IN2P3)
- 9 Orsay, Institut de Physique Nucléaire (CNRS-IN2P3)

Spokesman : M. de Saint Simon
Contactman : M. de Saint Simon

SUMMARY

We propose to take benefit of the fast and accurate measurement process obtained from a Smith type mass-spectrometer to undertake a program on the direct mass determination of nuclei with half-lives shorter than 1 second. These nuclei are located at the borderline of the ISOLDE production capability ; their mass values should allow for a stringent test of nuclear models and mass formulas far from stability. The resolving power of the radio-frequency mass spectrometer ($m/\Delta m = 10^5$) is high enough to rule out any isobaric contamination and to allow for an accuracy of $5 \cdot 10^{-7}$, (50 keV at $A = 100$).

Keyword : RFMASS

I. PHYSICS MOTIVATION

1. Far from stability mass determination

The aim of the experiment is to perform accurate direct mass measurements of nuclei located far from the nuclear stability, with half-lives shorter than 1 second, a domain very difficult to reach with the Penning trap technique already in use at ISOLDE (ISOLTRAP IS302). We propose to use a Smith type mass spectrometer [1], the so-called Radio-Frequency Mass-Spectrometer (RFMS) which has been built by the CSNSM (Orsay) [2] and which represents a decade of experimental development. The set-up had the double purpose of nuclear mass determination without the chemical selectivity observed in our previous mass spectrometer used at ISOLDE [3], and of a very precise mass comparison of proton and antiproton masses aiming at an experimental test of the CPT theorem. Priority had first been given to the second topic, leading to a resolving power $R = m/\Delta m \approx 10^6$ and a transmission of 10^{-4} . With some adjustments, this equipment can also provide good characteristics in the field of mass determination with a more suitable compromise, for technical reasons, between a reduced resolving power still as high as 10^5 and a higher transmission of 10^{-2} . In the next discussion, we will focus on the nuclei with half-lives in-between 1 ms and 1 s, and fulfilling the 2 following conditions : firstly, to be produced at ISOLDE with a minimal yield of 10 atoms/ μC taking as reference the yields obtained at ISOLDE II/III with the SC beams and secondly, the expected accuracy (from $5 \cdot 10^{-7}$ to $1 \cdot 10^{-6}$ according to statistics) should be better than the presently known by a factor 2 at least. More than 100 nuclei fulfil these criteria (Figure 1).

The ground-state mass of a nucleus, as compared to the sum of the masses of its constituents gives its total binding energy, a global quantity which embodies all the effects of the interacting forces in the nucleus. Therefore, accurate experimental mass values and the observation of their trends over the whole atomic mass table [4] is a good opportunity to scrutinize modifications of the structure, revealing changes as shell effects, pairing effects or nuclear deformation for instance in domains of N or Z where the nuclear structure is still not well established. This exploration has to be performed as far as possible from the stability line to exhibit the behaviour of the structure for extreme isospin values. It could be undertaken with alkaline and noble gas isotopes for which the ISOLDE yields are particularly high. Experimental mass values, far from stability, provide a stringent test of nuclear models and help to upgrade them in order to make improved predictions further away from stability up to regions of astrophysical interest. The present accuracy of nuclear models in predicting binding energy is around 0.5 MeV to be compared with nuclear structure effects ranging from 5 MeV for shell structures to less than 1 MeV for subshells, deformations or pairing energies. Thus, in the general case, an accuracy better than 100 keV or $\Delta m/m$ of 10^{-6} for $A = 100$ is highly desirable. In some particular cases, higher accuracies may be required. Now, we will focus on specific cases of interest.

2. "Halo" nuclei

The observation [5] of a spatially extended neutron halo in ^{11}Li and few other nuclei at the neutron drip line ($^8\text{He}, ^{11}\text{Be}, ^{14}\text{Be}$) has found a large interest in the last years. Although our knowledge of ^{11}Li has considerably increased, one still misses a model that would give a coherent description of all the parameters implied in the observations: matter distribution, halo size, halo separation energy, two-neutron removal cross-section, momentum distributions and possible n-n momentum correlations, potential geometry and depth... These parameters are strongly dependant on the binding energy. For example, in the quasi-molecular model [6], the key to the size of the halo is its separation energy S , since the halo size scales directly with $1/\sqrt{S}$ and the differential Coulomb cross-section near 0° with $1/S^2$. Hence the most interesting cases are characterized by low values of S , and by the necessity of a small error on this quantity for the theoretical predictions. Thus, a low value of S appears to be the key parameter for the existence and the extension of the halo.

The mass of ^{11}Li is now well known, since a recent determination [7] through a transfer reaction Q-value at Michigan State University leads to a weighted average of 324 (18) keV. Waiting for the next publication of the MSU result, we still feel that a verification is necessary, but no longer a priority as it was in our letter of intent (ISC/I5). We could improve the accuracy at the level of 5 keV for ^{11}Li (2n halo) and, in addition, to obtain an accurate mass determination of other candidates for the particular structure of neutron or proton "halo" such as : ^{33}Na (n), ^{31}Ar (p, 2p), ^{35}K (p), ^{61}Ga (p), ^{114}Cs (p), ^{149}Tm (p), ^{189}Bi (p), $^{195-197}\text{At}$ (p).

3. Nuclear deformation

Considering the onset of deformation, a case of interest is $^{31,32,33}\text{Na}$ [8] for $N = 20-22$ where a sharply localized deformation occurs. This deformation has been related to a deformed intruder state which has dropped below the energy of the normal spherical state ($0f_{7/2}$ $0d_{3/2}$ inversion). In addition, the increasing value of S_{2n} with N should be cleared up. The mass accuracy could be improved for the isotopes $^{27-33}\text{Na}$, and for the neighbouring $^{24,25}\text{F}$, $^{26-30}\text{Ne}$, ^{30}Mg , ^{32}Al . In a similar way, binding energies could be determined more accurately for the neutron rich isotopes around $N = 60$: $^{99-102}\text{Rb}$, $^{99-101}\text{Sr}$, ^{101}Y .

4. Wigner effect

This effect is related to a cusp occurring at the $N = Z$ line in the nuclear mass surface. In most of the models, it appears to be related to a term in the binding energy which is proportional to isospin and hence for the ground states proportional to $|N - Z|$. Since terms linear in N and Z are present in every expression for the binding energy, the Wigner term can easily be absorbed into those and is poorly known for N and Z above 30. It can be revealed by mass measurements near and across the $N = Z$ line : ^{66}As and ^{74}Rb (self-conjugate nuclei), and ^{61}Ga , ^{63}Ge , ^{67}Se , ^{71}Kr ($N = Z - 1$ nuclei) which are respectively mirror nuclei of ^{61}Zn , ^{63}Ga , ^{67}As , ^{71}Br .

5. Models and mass formulas

As an example, experimental masses of far from stability nuclei are useful for testing the charge symmetry which is assumed in various mass formulas such as the isobaric mass multiplet equation (IMME) [9] and the Garvey-Kelson relationship [10]. Moreover, halo nuclei could be revealed by deviations from IMME. A precise mass measurement of the members of the multiplet is required to provide a meaningful test of the quadratic relationship of the IMME and to determine possible higher-order terms. For the isobaric quartet $T = 3/2$, ^{33}Ar , ^{35}K , for the $T = 2$ quintet : ^{20}Mg could be improved, and for $T = 5/2$, ^{31}Ar could be the first member to be measured. Models could be tested with $^{150-152}\text{Cs}$, which are particularly far from stability in this domain of mass number.

6. Improvement of current data

We can underline some specific cases where disagreements between experimental data, related to different measurement techniques, might be cleared up (the discrepancy is indicated in keV) : ^{50}K (1200 keV), ^{62}Mn (500 keV), ^{63}Mn (900 keV), ^{80}Zn (400 keV), ^{99}Rb (120 keV), ^{99}Sr (330 keV), ^{100}Sr (450 keV) . In addition, it should be useful to clarify some discrepancies between experimental data and "regularities of the mass surface", for the following nuclei: $^{29,30}\text{Ne}$, ^{44}Cl , ^{66}As , ^{99}Sr , ^{101}Rb , ^{114}Cs , ^{116}Cs , ^{147}Ba . A particular interest in the regions of shell closure far from stability : ^{23}O , ^{24}F , ^{25}F , $^{31,32,33}\text{Na}$, ^{53}Ca , ^{134}Sn should be given. Long chains of α emitters are known from Q_α measurements. They have to be connected to the rest of the mass table through the mass determination of one member of the chain: ^{189}Bi , $^{192-194}\text{Po}$, $^{196-197}\text{At}$, for instance. In some cases mass triplets measurements could benefit from an independent measurement of some extreme nuclei, achieving a calibration of the systematic effects : ^{147}Cs , ^{148}Cs .

7. Half-life determination

The half-life of more than 20 nuclei (^{29}Ne , ^{30}Ne , ^{44}Cl , ^{47}Ar , ^{88}As , 93 , ^{94}Br , $^{96,97}\text{Kr}$, $^{101,102}\text{Rb}, \dots$) among the hundred of them for which mass values could be determined, is poorly known or unknown. That determination requires a high resolving power since the most interesting beams usually have important isobaric contaminations. Such a beam purification could be obtained from our set-up.

To summarize, more than 60 nuclear masses of specific interest could be determined using the yields from the SC beam. At the PS-Booster, we can hope that higher yields would allow for an even larger number of nuclear masses, further from stability, to be measured. At the first stage, we will concentrate our physics program on light nuclei : halo nuclei, deformation in the Na isotope region.

II. STATUS OF ATOMIC MASS MEASUREMENT

Mass-spectrometry has had a very long history in Nuclear Physics. Since the pioneering work, in the 70's, of Klapisch and Thibault on direct mass-measurements of radioactive species, several projects have reached maturity and in the last 7 years they have given a big amount of results for exotic species, extending significantly our knowledge of the mass surface. Techniques to perform nuclei identification and mass determination have led to a variety of methods, most notable among them are the use of on-line isotope separators or mass spectrometers and the development of recoil spectrometers or separators.

1. β and reaction Q-values

Many nuclear masses were determined from Q-values of nuclear decays or reactions. However, mass determination using Q_β requires a precise knowledge of the decay scheme, which becomes more complex further from stability. The use of transfer reactions becomes more and more difficult going further from stability because of smaller cross-sections, unknown reaction mechanism and contamination of the target material. As a consequence, these indirect mass determinations have been responsible for several discrepancies and inconsistencies. Direct mass measurements are more reliable. Also, we will concentrate now upon direct mass measurement techniques.

2. Time of flight

With the time-of-flight mass spectrometers SPEG [11] at GANIL, and TOFI [12] at LAMPF, the ions of the "secondary" produced radioactive beam are identified and their mass measured from their time-of-flight. These techniques are characterized by far exploration for extended isospin regions and even for very short lived species ($\approx 1 \mu\text{s}$). The resolving power $m/\Delta m$ is around 10^4 and isobaric cross-contamination can introduce significant errors. The final precision of such measurements is limited by the length of the time of flight base and the statistics, practically it stands at the level of 3. to 5. 10^{-5} . Systematic errors are corrected with an empirically determined function which is extrapolated to unknown masses. One advantage of the recoil spectrometers is that the measurement is performed directly at the fragment velocity of several nuclei simultaneously. This technique is well suited to mass measurements of light nuclei ; they have made a good harvest of data in that domain.

3. Accelerator as mass spectrometer

The basic idea is to use the isochronism of trajectories in a cyclotron (CSS2 at GANIL [13]) and in a storage ring (ESR at GSI with cooled beams [14] and in isochronous mode [15]) to get a very long base of time of flight. The resolving power should be at the level of $2 \cdot 10^3$ per turn. These attempts should be considered as projects. The limiting factors are the quality of the isochronism of the machine and the possibility to keep a good control of the trajectory in order to take care of systematic errors. The GSI method aims at an accuracy of $3 \cdot 10^{-7}$ and $5 \cdot 10^{-6}$ is expected at GANIL.

4. Cyclotron frequency

The methods which are relying upon the cyclotron frequency determination have 2 advantages : only one parameter has to be measured and it is a frequency, the physical quantity which is determined with the best accuracy.

The advent of Penning trap mass measurements has brought to nuclear masses a drastic improvement in accuracy. The ISOLTRAP experiment [16] is based upon the Penning trap technique which has been used with bright success for mass determinations of light particles (e^- , p , \bar{p}). The technique had to be adapted to heavy ions. The resolving power is at the level of $10^8/A$ providing an accuracy around 10^{-7} . The masses of isotopes with half-lives from 100 ms to 1 s can be measured with some sacrifice on accuracy. For shorter half-lives, mass determination of isotopes is very difficult due to the time taken by the collection and the cooling process, followed by the measurement procedure in the precision trap. An other disadvantage of the current technique is the chemical selectivity due to the surface ionization, restricting the method at alkaline and alkaline-earth elements. In a next stage, this situation should be improved by using laser desorption and getting better bunching efficiency. In a further improvement, a Paul trap installed downstream the collection trap, will avoid the collection in a filament and thus, the chemical selectivity.

The Radio-Frequency-Mass-Spectrometer (RFMS) we propose to use rely on the principle used by Lincoln Smith in the 60's to make very accurate mass measurements (10^{-10}) for stable species [17]. It allows for the direct determination of the cyclotron frequency at the ISOLDE beam velocity ; since the beam is injected directly in the magnetic field of the spectrometer, the method is no longer restricted by chemical selectivity or duration of the measurement process. The resolving power of 10^5 allows for getting rid of isobaric cross-contamination and the final accuracy should be from $5 \cdot 10^{-7}$ to $1 \cdot 10^{-6}$ according to statistics. Thus, taking into account the diffusion time in the ISOLDE ion source, this type of transmission spectrometer ideally complements the ISOLTRAP device in the half-life range from 1 ms to 1 s.

III. EXPERIMENTAL METHOD

1. Principle of the Smith spectrometer

The cyclotronic motion of a charged particle inside a static and homogeneous magnetic field provides the connection between mass and frequency. The cyclotron frequency is given classically by $f_c = qB_0/m$. If the magnetic field is stable enough, the frequencies and masses of two ions A and B, rotating alternatively along the same trajectory, are linked by the relationship $m_A f_A = m_B f_B$ similar to the one relating mass and voltage in a classical mass spectrometer. The main parts of the set-up (Figure 2) consist of a magnet with a highly homogeneous field, a fourfold radio-frequency modulator, and 2 symmetrical lines for injection and ejection of the beam ; the ejection line ends up with a detector chamber in order to count the transmitted ions. The ISOLDE beam is directly injected into

the homogeneous area of the magnetic field by an electrostatic cylindrical deflector (± 5 kV) which is the last element of the injection line. A vertical pitch is given by an electrostatic dipole. After 2 turns inside the magnet, it is ejected by a second deflector. Inside the magnet, the ions follow an helicoidal trajectory with a mean radius $R_0 = \sqrt{2mT_0}/qB_0$ where T_0 is the kinetic energy. The diameter of the trajectory is 1 m. At the end of the first and third half-turn, it crosses the RF modulator. The modulation frequency f is adjusted so that the accelerating RF field has opposite phase for the 2 crossings. In these conditions, the final acceleration (after 2 turns) is null, and the transmission through the system is maximum. When the frequency is scanned, sharp peaks are obtained. They are centred on the resonance frequency which is related to the cyclotron frequency by the relationship : $f = (n + 1/2) \times f_c$ where n is an integer : the harmonic number [18]. The resolving power R is given theoretically as $R = 2\pi n \times (D_m/w)$ where D_m is the modulation amplitude of the diameter and w the common width of the inlet, modulator, and exit slits. We have to notice that the resolving power is proportional to the harmonic number and independent of the mass number A of the nuclei, encouraging to run with high frequency with constant resolution over the full mass range. A phase defining slit is located at the opposite side of the RF modulator with the purpose to suppress tails around the peak, but lowering the transmission. Resolving power limitations result from departure from isochronism related to the inhomogeneity of the field. With the same magnet, but a different set of parameters, a resolving power of 10^6 has been reached.

Multiparticle simulations with the specific parameters for the ISOLDE situation, specially beam emittance in the **slit source mode**, which allows for good beam matching with our slits, exhibit a resolving power of 10^5 with slit width of 0.4 mm corresponding to a transmission better than 1% (Figure 3). The transmission has been calculated from the acceptance of the RFMS determined by geometrical factors and from the ISOLDE beam emittance in slit mode ion source [19]. The reduction of the resolving power from 10^6 to 10^5 that is leading to a similar value of the $R \times T^2$ product where T is the transmission, has been chosen for 2 reasons. Firstly, a better signal to noise ratio for low yield nuclei is obtained and secondly, the floor space required for extra energy filters is reduced.

2. Data taking process

The comparison of the unknown mass A and the known mass B is based on the recording of the shape of the resonance peaks : the spectrometer transmission is recorded in a multichannel analyzer versus the frequency applied to the modulator. In order to get rid of long term magnetic field fluctuations the recording of the mass A peak is done in-between 2 recordings of the mass B peak. Of course the delay which separates the RF scans should be as short as possible (≈ 200 ms). The 2 recordings of the mass B is equivalent to the determination of a mean value of the magnetic field at the moment of the peak A recording. The selection of the harmonic number has to be done so that the frequencies for peak A and B are as close together as possible in order to stay in the bandwidth of the RF system. As we are running at **constant magnetic field**, the kinetic energies of the ions A and B , thus the ISOLDE acceleration voltage and the voltage of all the electrostatic components of the system including ISOLDE beam transport lines have to be modified in order to cope with the

relationship : $m_A V_A = m_B V_B$. Such voltage jumps should not last longer than 200 ms in order to maintain magnetic field fluctuations below the expected accuracy of $5 \cdot 10^{-7}$. For a duration larger than 300 ms, the total duration of the measurement process will exceed 1.2 s, the repetition time of the PS-Booster, leading to a loss of statistics. It has to be noticed that no jump of the magnetic field is required.

Unfortunately, as the PS Booster-ISOLDE is providing a pulsed structure to the radioactive beam, specially for the very short half-lived nuclei under consideration, the peak of the mass A should be reconstructed from several measurements at selected frequencies, because the duration of the production profile is too short to make a frequency scanning lasting around 300 ms. As in the continuous beam case, the fixed frequency measurement is made in-between 2 frequency scanings of the peak of the known mass B which should be a stable or a long-lived nuclei. In this mode the determination of the spectrometer transmission requires the beam current monitoring, which is obtained by measuring the beam current with the RF power off during a part of the production profile. Using a similar procedure in the much more difficult environment of LEAR with the cycling PS magnetic field, an accuracy of $5 \cdot 10^{-8}$ has been measured for the determination of the center of the peak.

3. Accuracy and systematic errors

In order to discuss the accuracy of the method, we can make use of the following relationship :

$$\frac{\sigma_m}{m} = \left[\frac{1}{N} \left(\frac{1}{2.45 R} \right)^2 + \left(\frac{\Delta B}{B} \right)_{\text{stab.}}^2 + \left(\frac{\Delta m}{m} \right)_{\text{syst.}}^2 \right]^{1/2}$$

where σ_m/m stands for the mass measurement accuracy, the first term corresponds to the accuracy of the determination of the center of the peak in the data analysis process, related to the resolving power R and to the statistics N , the second term refers to the stability of the magnetic field in the time range required to alternate mass A and B and the third term embodies the systematic errors. The first term can be evaluated to $5 \cdot 10^{-8}$ with $N = 10^4$ events in the peak corresponding to the accumulation $2 \cdot 10^6$ ions from the Isolde beam, taking into account the transmission of the set-up and the triangular shape of the peak. The second term has already been measured to $5 \cdot 10^{-8}$. The systematic errors will be evaluated from mass measurements of very well known masses in the first stage of our experimental program at ISOLDE. Because of the cyclotron frequency technique, we can reasonably expect small systematic errors and an accuracy at the level of $5 \cdot 10^{-7}$ (50 keV for $A = 100$).

4. Sensitivity and data taking time

The limit of sensitivity is related to the background of the detector, a secondary electron multiplier used to detect the secondary electrons produced by the impact of the ions against an aluminum tape which is moving away in order to get out the radioactive nuclei and to get rid of background from their decay. According to previous experiments in a similar environment (PS - East Hall and ISOLDE) the resulting background should be below 0.1 count/s. Taking into account the pulsed structure of the beam and the RFMS transmission, our limit is an ISOLDE beam yield of 10 atoms/ μ C.

A mass measurement with an accuracy of $5 \cdot 10^{-7}$ requires $2 \cdot 10^6$ ions from ISOLDE. It can be obtained within 2 hours for a yield of 10^3 atoms/ μC . To get a similar accuracy with a yield of 10^2 atoms/ μC , it requires 1 day of beam time. With a yield of only 10 atoms/ μC and 2 days of data taking, a reduced accuracy of 10^{-6} could be obtained.

IV. TECHNICAL CONSIDERATIONS

1. Technical data

- **Magnetic field** : the maximum value of the magnetic field in the gap is 0.8 T, the stray field has been measured to $4 \cdot 10^{-2}$ T at 1 m and $1.5 \cdot 10^{-2}$ T at 2 m from the center of the magnet.
- **Electrostatic field** : as in the ISOLDE beam lines, electrostatic devices (deflectors, dipoles, quadrupoles and hexapoles) are in use. The maximum value of the voltage is ± 5 kV when ISOLDE is running at 60 kV. For $A > 100$, we have to operate at a lower kinetic energy : 30 keV for $A = 250$.
- **RF field** : the output power of the RF transmitter is 1 kW (cw) in the frequency range from 200 to 500 MHz, the power is transported from the electronics area of the experiment to the RF modulator through a low loss coaxial line.
- **Vacuum** : the chamber and all the equipments of the RFMS have been built with UHV standard (metallic gaskets, bakable device). The regular pressure is 10^{-8} mb. The pumping system is consisting of mechanical fore-pumps, turbo-molecular and ionic pumps.
- **Beam diagnostics** : the spectrometer is equipped with 4 permanent diagnostic detectors (in-out systems): beam spot observation (MCP, phosphor screen), beam current monitoring (Faraday cup, channeltron, MCP).

2. Safety

Except high voltage of 5 kV, no harmful elements are in use : no ionizing radiation except radioactivity brought by the ISOLDE beam, no laser, no gas except compressed air. No shielding is required to protect the environment from the spectrometer.

3. RFMS operation

- **Running period** : before the beginning of a run period, the RFMS has to be operated during 4 days to make adjustments and to reach stabilization of the parameters. At the cold start of the RFMS (and after each of the power cuts) a cycle for demagnetization of the magnet is performed. It is made of many polarity reversals of the field and it is lasting 30 minutes. This operation could produce some perturbations on a nearby beam. As in several other experiments with delicate beam handling, the trajectory in the RFMS is sensitive to the crane movement. The spectrometer is also sensitive to temperature fluctuations and opening the gate of the loading area of the experimental hall has to be avoided during operation. Such crane or gate movements needed by other users have to be scheduled carefully during RFMS running time.

- Idle period : generally, the spectrometer is switched off just at the end of the running period. All magnetic, electrostatic and RF fields are switched off. Only the pumping system remains running.

4. RFMS layout

The RFMS is shown in figure 4. THE ISOLDE beam line should end up with a beam scanner. This one will be connected to a valve and to the first beam diagnostic chamber of the RFMS. The focus of the ISOLDE beam line could be located in this chamber, but we can also accept a roughly parallel beam in this section. Any beam line is suitable to install the RFMS, as long as the floor space available is large enough : 3.5 x 4.0 m². Probably, a small sized shielding is required around the detection chamber to lower the background level at the detector location. About electronics, only 2 racks are required to stand close to the spectrometer for the pumping control. All other electronic crates (12 racks) can be gathered in a small control room : 3 x 5 m² (figure 5). The more convenient location for this control room is beside the spectrometer. If a further location of the electronics is mandatory, the distance between the RFMS and the control room should be preferably less than 15 m ; otherwise, any location is possible inside the experimental hall, but, 2 more racks have to be set close to the spectrometer, and all the existing cables have to be made again. 5 BNC cables are needed between the RMS control room and the ISOLDE control room for trigger signals, a link with the ISOLDE control system is also required.

It would be very convenient to use a small counting room : 4 x 4 m², in the building 507 to install our computer (Sun workstation) and some TV monitors used for the control of the experiment during the running time. This counting room should be equipped with an Ethernet link towards the CERN computer network and, towards the RFMS, 10 BNC cables and a private Ethernet link to the VME crate for the control and data acquisition systems. Obviously, a link with the ISOLDE control system is also required. In the case where such a counting room could not be used, the electronics area should be larger than foreseen (4 x 5 m²) in order to control the experiment from that location. In addition, as the experiment involves a lot of equipments, we are particularly interested in getting space in the nearby building 507 to store them.

The RFMS should be fed with electric power : 75 kW, demineralized water for the cooling of the magnet (10 bars, 40 liters/minute, $\Delta t \approx 3$ °C), regular water for cooling of the magnet power supply and RF transmitter (low flow) and compressed air for detector movement.

V. TIME-TABLE AND BEAM TIME REQUEST

In the case of approval of the experiment, the installation which should last 2 full months, has to be scheduled during the PS shut-down, in order to not affect the users taking data. Then, we will have to face the delicate first setting-up of the trajectory inside the spectrometer, using stable beams from ISOLDE. Probably, the starting-up of the spectrometer and the initial setting-up will take also 2 full months. At that time, we will be able to start the first mass measurements which will be devoted to

systematic error evaluation and correction. This stage requires radioactive beams and could be considered as a data taking situation.

Looking at the beam time for, approximately, the first year of running, a stable beam for the initial setting-up of the RFMS is the first priority. We need a stable isotope such as ^{87}Rb during 4 times 1 week (4 x 15 shifts of 8 hours of beam time) over a period of approximately 2 months. Then, a survey of systematic effects has to be carried out with stable and radioactive beams : 3 runs of 12 shifts of beam time are required for that purpose over a period of 4 months. At that time, the data taking for physics should start up with the onset of deformation occurring in the neighbouring of neutron rich Na isotopes : $^{24,25}\text{F}$, $^{26-30}\text{Ne}$, $^{27-33}\text{Na}$, ^{30}Mg , ^{32}Al . The first run will be devoted to the mass measurement of $^{27-33}\text{Na}$ during 16 shifts of 8 hours. This program could be carried out using an uranium carbide target and a tungsten surface ionization source.

<u>Beam</u>	<u>Min. intensity</u>	<u>Target material</u>	<u>Ion Source</u>	<u>Shifts</u>	<u>Exp.</u>
^{87}Rb	$6 \cdot 10^9/\text{s}$	Thorium carbide	W surf. ion.	4x15	Initial setting-up
^{88}Rb - ^{99}Rb	$\geq 4 \cdot 10^5/\text{s}$	Thorium carbide	W surf. ion.	12	Systematic effects
^{45}Ca - ^{51}Ca	$\geq 1 \cdot 10^4/\text{s}$	Tantalum powder	W surf. ion.	12	Systematic effects
^{24}Na - ^{27}Na	$\geq 4 \cdot 10^5/\text{s}$	Uranium carbide	W surf. ion.	12	Systematic effects
^{27}Na - ^{33}Na	$\geq 1 \cdot 10^5/\text{s}$	Uranium carbide	W surf. ion.	16	Mass measurement

The ion source has to be in slit mode. Of course, new beam requests with more details will be done in order to continue the physics program.

REFERENCES

- [1] L. G. Smith, Proc. Int. Conf. on Nuclidic Masses, ed. H. E. Duckworth (Univer. of Toronto Press, Toronto, Canada, 1960) p. 418.
- [2] A. Coc, R. Fergeau, C. Thibault, M. de Saint Simon, F. Touchard, E. Haebel, H. Herr, R. Klapisch, G. Lebée, G. Petrucci, and G. Stefanini, Int. Rep., Rep LRB 85-01, CSNSM, Orsay (1985).
- [3] G. Audi, A. Coc, M. Epherre-Rey-Campagnolle, G. Le Scornet, C. Thibault, F. Touchard, Nucl. Phys. A449 (1986) 491.
- [4] A. H. Wapstra, G. Audi, Nucl. Phys. A432 (1985) 1.
- [5] I. Tanihata et al., Phys. Rev. Lett. 55 (1985) 2676;
- [6] P. G. Hansen and B. Jonson, Europhys. Lett. 4(1987)409.
- [7] W. Benenson, private communication.
- [8] C. Thibault, R. Klapisch, C. Rigaud, A. M. Poskanzer, R. Prieels, L. Lessard, and W. Reisdorf, Phys. Rev. C12 (1975) 644.
- [9] Wigner E. P., in Proc. Robert A. Welch, Conf. on Chemical Research, Houston: Welch Foundation (1957) 67.
- [10] G. T. Garvey and I. Kelson, Phys. Rev. Lett. 16 (1966) 197.
- [11] A. Gillibert, W. Mittig, L. Bianchi, A. Cunsolo, B. Fernandez, A. Foti, J. Gastebois, C. Grégoire, Y. Schutz and C. Stephan, Phys. Lett. 192 (1987)39.
- [12] J. M. Wouters, D. J. Vieira, H. Wollnik, H. A. Enge, S. Kowalski, K. L. Brown, Nucl. Instr. and Meth. A240 (1985) 77.
- [13] P. Bricault, G. Auger, M. Bajard, D. Bibet, A. Chabert, J. Fermé, L. Gaudart, J. Joubert, M. Lewitowicz, W. Mittig, E. Plagnol, C. Ricaud, Y. Schutz, Int. Conf. on Cyclotron and their application, Vancouver, 6-10 july 92.
- [14] B. Franzke, H. Geissel and G. Müzenberg, GSI-proposal, 1986, unpublished.
- [15] J. Trötscher, K. Balog, H. Eickhoff, B. Franczak, B. Franzke, Y. Fujita, H. Geissel, Ch. Klein, J. Knollmann, A. Kraft, K. E. G. Löbner, A. Magel, G. Münzenberg. Nucl. Instr. and Meth. B70 (1992) 455.
- [16] G. Bollen, H.-J. Kluge, Th. Otto, G. Savard, L. Schweikhard, H. Stolzenberg, G. Audi, R. B. Moore, G. Rouleau and the ISOLDE Collaboration, Jour, of Mod Optics, 39 (1992) 257.
- [17] L. G. Smith, Phys. Rev. C4 (1971) 22.
- [18] A. Coc, et al., Nucl. Instr. and Meth. A271 (1988) 512.
- [19] E. Kugler, D. Fiander, B. Jonson, H. Haas, A. Przewloka, H. L. Ravn, D. J. Simon, K. Zimmer and the ISOLDE Collaboration, Nucl. Instr. and Meth. B70 (1992) 41.

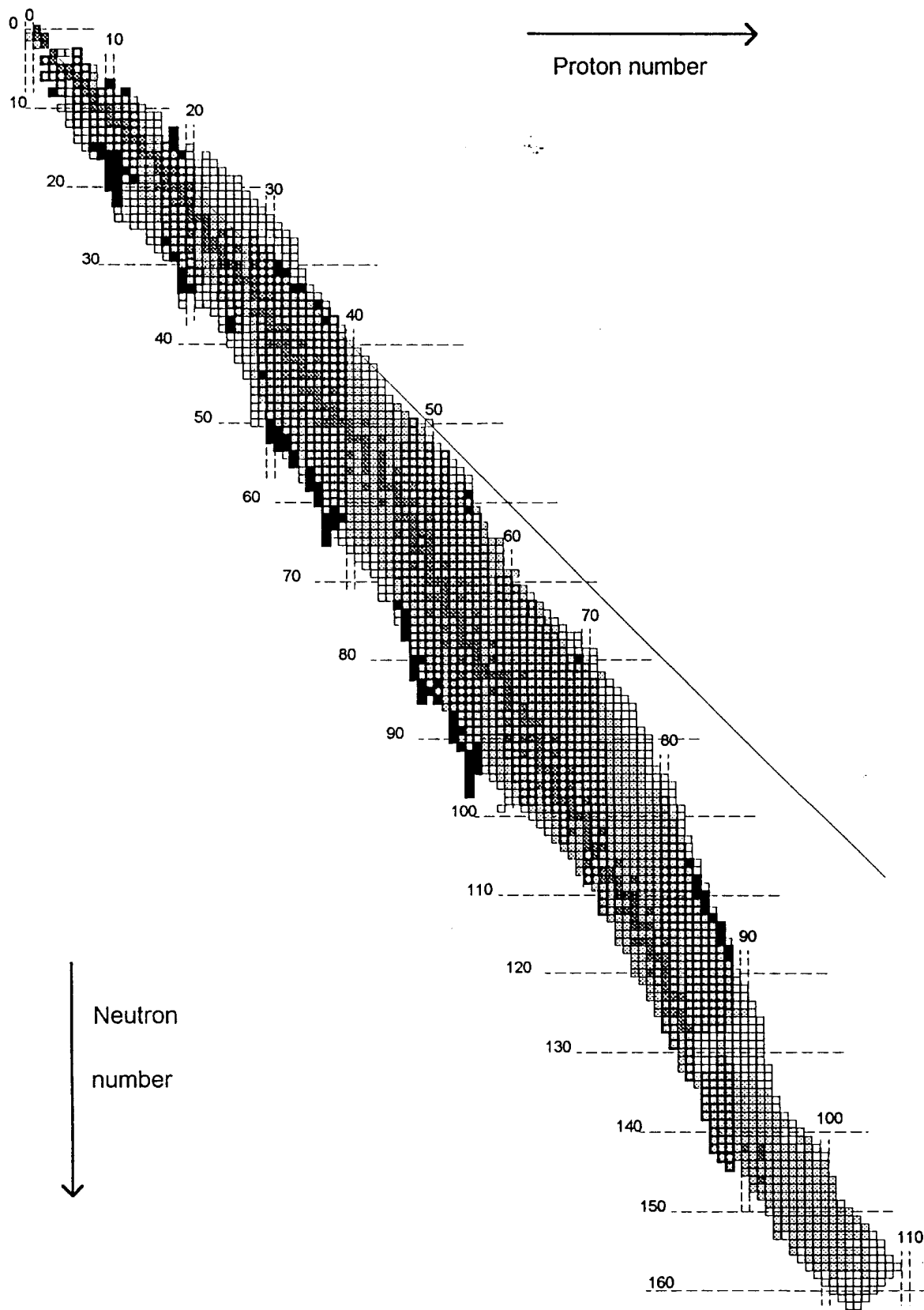

Figure 1. Chart of the nuclides displaying:

▣ nuclei with half-life $> 1s$

□ nuclei with half-life $\leq 1s$

▣ nuclei with a yield ≥ 10 atoms / μC

■ nuclei, with half-life $\leq 1s$ and a yield ≥ 10 atoms / μC : a new mass measurement or an improvement of the present accuracy by a factor > 2 can be obtained.

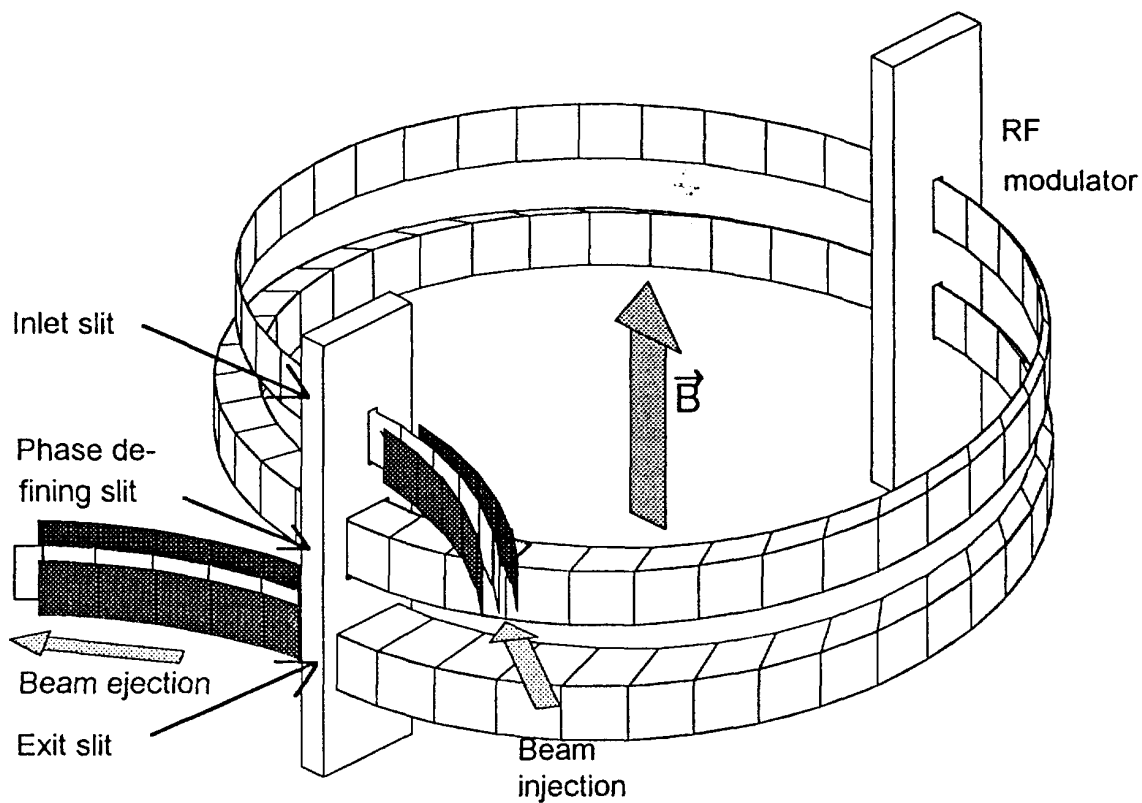

Figure 2. Principle of the RFMS. \vec{B} indicates the very homogeneous magnetic field.

RFMS SIMULATION

Particle/chan.

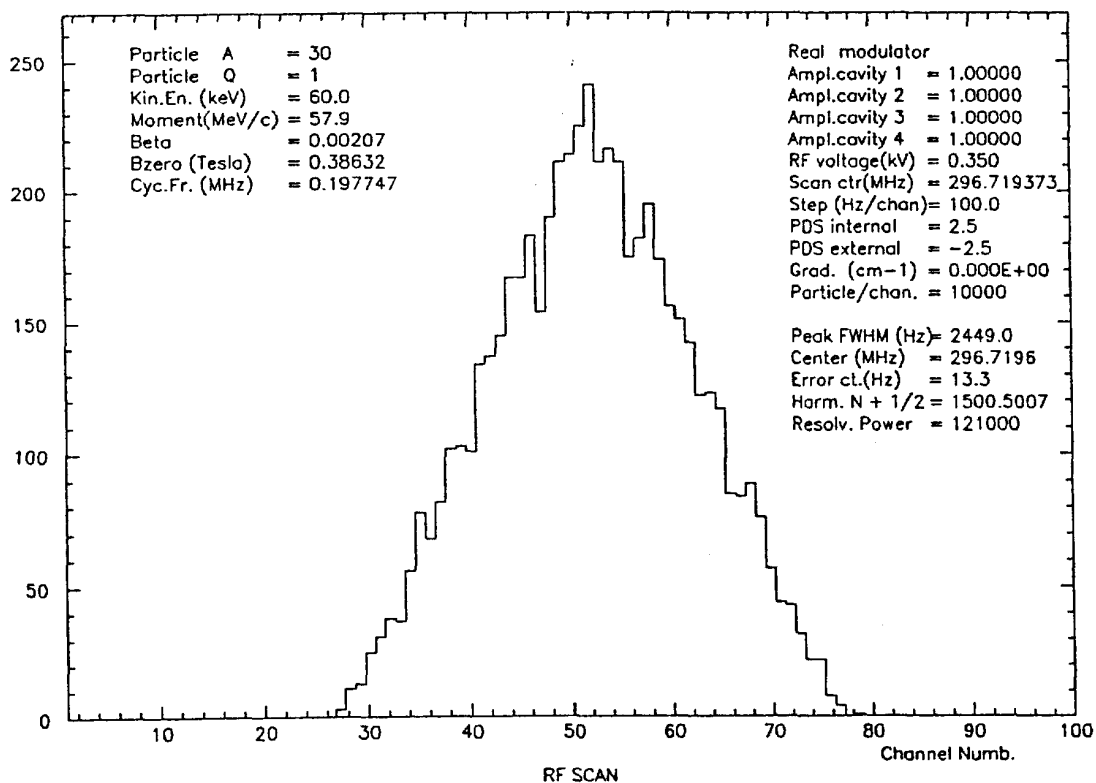

Figure 3. Multi-particle simulation for $A = 30$: the resonance peak exhibits a resolving power of $1.2 \cdot 10^5$ and a transmission for the central frequency of $2 \cdot 10^{-2}$, in the discussion, in order to be conservative, a resolving power of 10^5 and a transmission of 10^{-2} have been considered.

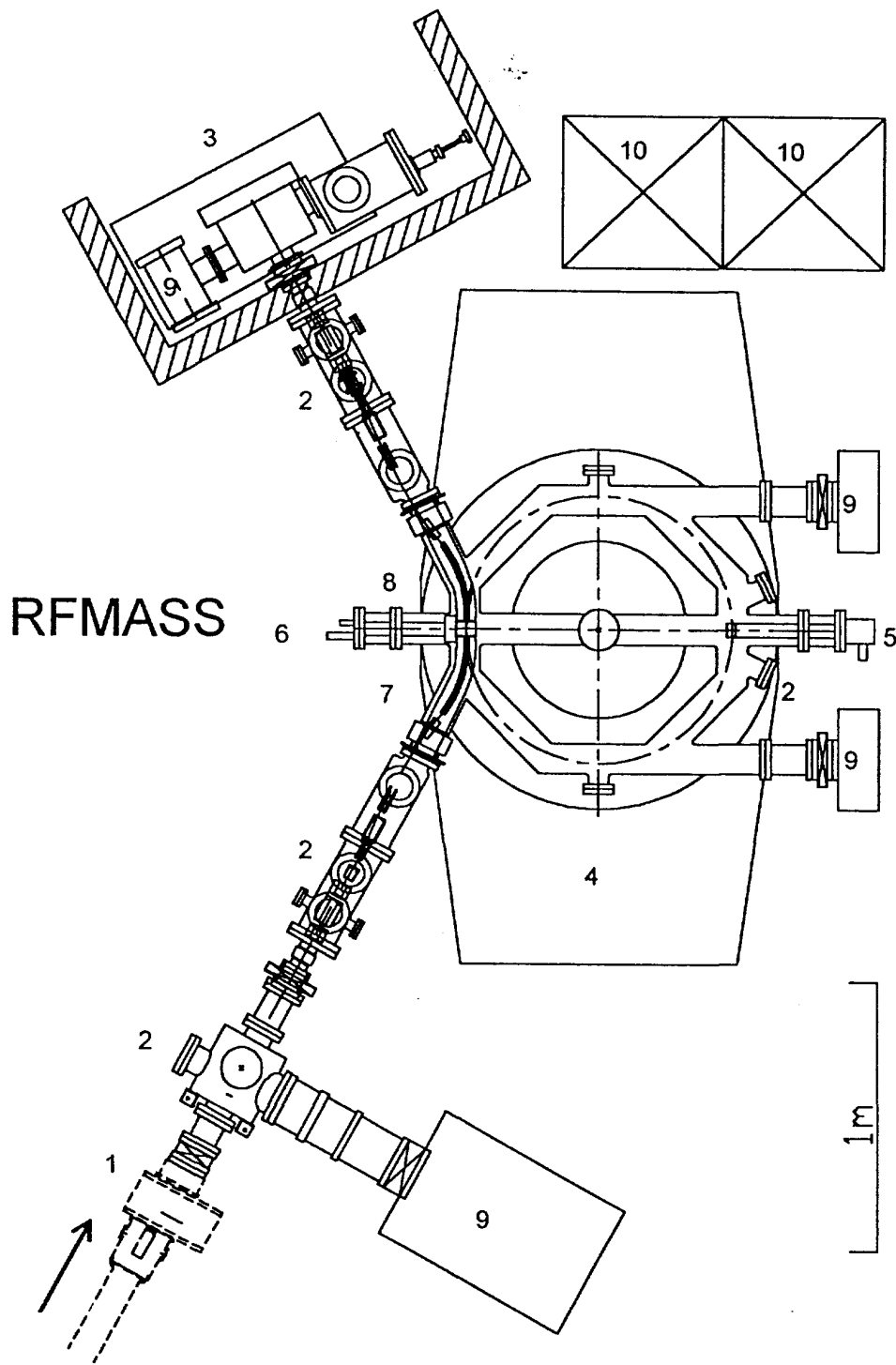

Figure 4. Layout of the RFMS:

- | | |
|------------------------------------|--------------------------------|
| 1. ISOLDE beam line / beam scanner | 6. Phase defining slit |
| 2. Beam diagnostic stations | 7. Beam injection |
| 3. Detector chamber and shielding | 8. Beam ejection |
| 4. RFMS magnet (25 tons) | 9. Pumping units |
| 5. RF modulator | 10. Pumping system electronics |

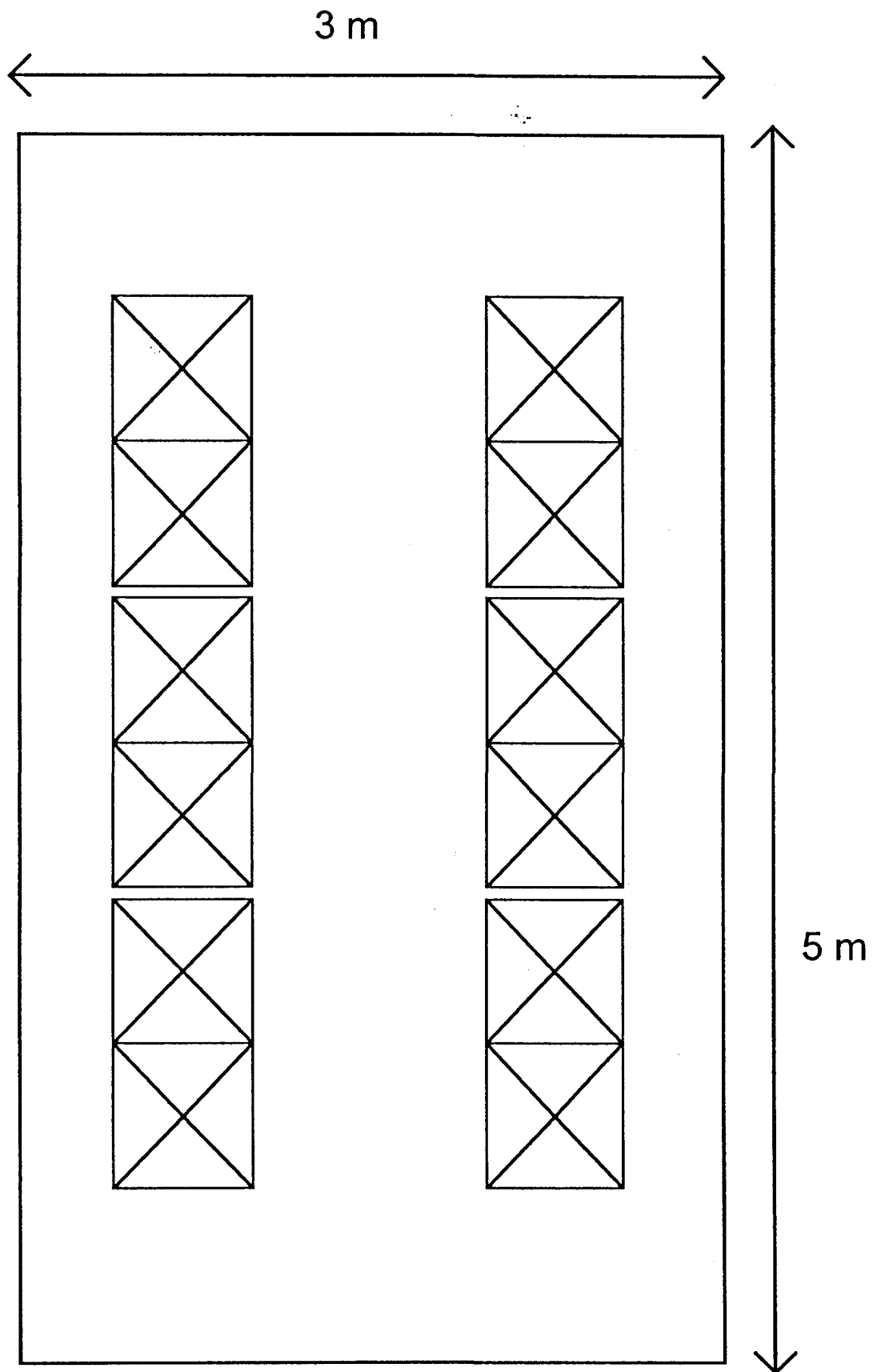

Figure 5. Electronics area. It could be located preferably beside the spectrometer or at less than 15 m.