

**THE HEXAGONAL TOROIDAL AIR-CORE MAGNET
OF THE CHORUS DETECTOR**

F. Bergsma, F. Cataneo, W. Flegel, H. Gerwig, P.-A. Giudici, J. Panman,
G. Petrucci and C. Rosset
CERN, Geneva, Switzerland

Abstract

We report on the hexagonally shaped toroidal air-core magnet used in the magnetic spectrometer of the CHORUS experiment at CERN. The novel and unique features of this magnet are the radially-constant field over its entire volume, with field lines straight and parallel to the hexagonal sides, and the negligibly small field-free region along its central axis. A detailed description of its construction and performance is given.

(Submitted to Nuclear Instruments and Methods)

1 INTRODUCTION

The CHORUS Collaboration has constructed a new detector for the study of neutrino oscillations [1]. Part of this detector is a magnetic spectrometer for the charge determination of low-energy particles of neutrino-induced events.

The magnetic spectrometer consists of a hexagonal toroidal air-core magnet, developed, designed, and constructed at CERN. It is preceded and followed by scintillating fibre tracker planes adapted to the special geometry of the magnetic field. The following gives a detailed description of this hexagonal magnet.

2 GENERAL DESCRIPTION OF THE MAGNET

The magnetic spectrometer of the CHORUS detector needed to have the following features:

- a toroidal magnet of large area, determined by the dimensions of the neutrino target
- a negligibly small field-free region along the central axis
- a minimal amount of material in the passage of traversing particles
- easy particle tracking with tracker planes close to the magnetic volume.

The above requirements were met by a hexagonal air-core magnet, composed of regular triangular sectors. The windings in each of these sectors are equidistant and orthogonal to the polygon side for the front and back faces, and parallel to the axis for the other planes. Figure 1 shows schematically the winding arrangement.

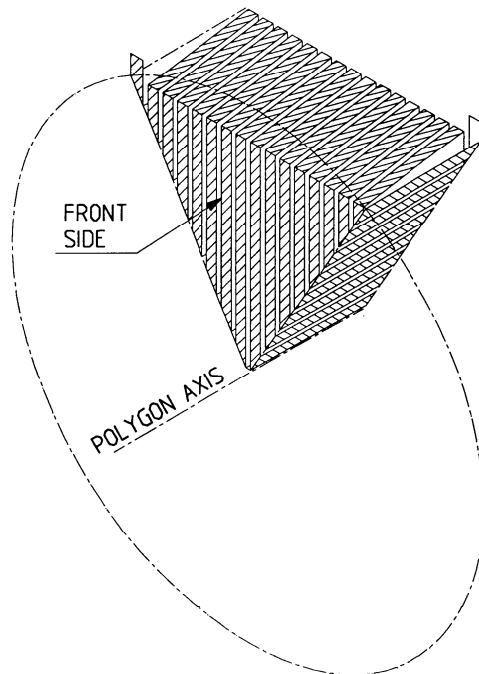

Fig. 1 Scheme of a toroidal sector

A toroidal magnet arranged in such sectors has novel and unique features:

- its field is constant over the entire volume (no radial dependence)
- the field lines in each sector are straight and parallel to the outer side of the polygon
- along the axis it has nearly no region with zero magnetic field
- only small regions along the diagonals are filled with material.

These specific properties hold for any polygonal toroidal magnet with the same-type winding arrangement. Its field can easily be calculated*.

Figure 2 shows an overall view of the CHORUS hexagonal magnet.

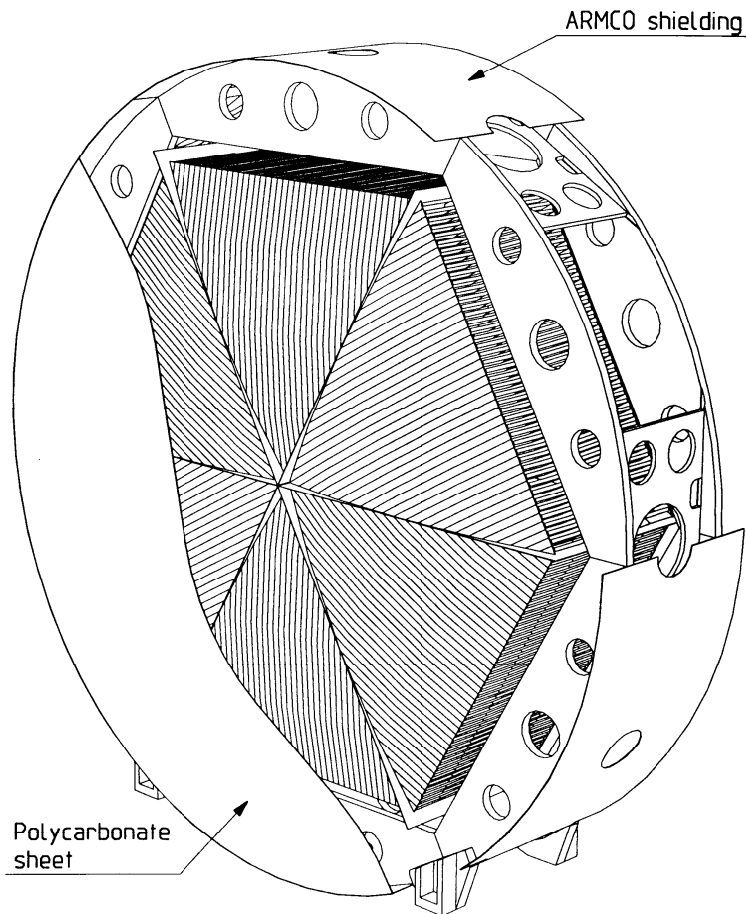

Fig. 2 The hexagonal magnet

The magnet is of a compact design. The conductors are made of Al-alloy 2.5 mm thick, representing just a few per cent radiation length for particles traversing the magnetized volume. Only the diagonal planes, where the conductors between the front and back faces are fixed to the support sheets, are of material all along the axial depth of the magnet. Its azimuthal thickness is about 11 mm.

The tracking in the target region of the CHORUS detector and at the magnetic spectrometer is performed by planes with straight scintillating fibres of 500 μm diameter, viewed at one end by chains of image intensifiers. The compact arrangement of the magnet conductors prevents any field leakage to the outside of the front and back faces of the magnet that could influence the nearby image intensifiers. A small leakage of 2 to 4 G at the hexagon sides arising from the cross conductors between the front and back faces is stopped by a 3 mm-thick ARMCO sheet around the outer diameter of the support frame.

* Any sector-shaped winding of this type creates a uniform field if the radial planes limiting the sector are kept at the same magnetic potential, for instance by means of flat iron polar faces connected by a return yoke. It is trivial in this case to verify that the acting ampere turns are increasing linearly from the sector vertex towards the outer edge, corresponding to the equal increase of the air-path length between the polar faces.

The neutrino beam is pulsed with two pulses of 6 ms length every 14.4 s. Operating the magnet in a pulsed mode, greatly reduces the average power dissipated in the windings and permits simple air flow cooling instead of the more risky and complicated water cooling (see Section 4).

The main parameters of the magnet are summarized in Table 1.

Table 1

Hexagon side length	1.5 m
Axial length	0.75 m
Conductor material	E – Al Mg Si 0.5 (DIN)
Conductor thickness at front & back face	2.5 mm (total: 5.6 % rad. length)
Conductor width at front & back face	32 mm
Radius of front & back face curvature	3550 mm
Magnetic inductance	1180 G
Total number of turns	264
Maximum current	3200 A
Voltage at maximum current	720 V
Effective pulse length	~ 55 ms
Flat top length	~ 12 ms
Effective power (2 pulses / 14.4 s)	~ 17 kW
Ohmic resistance	215 mΩ
Inductance	4.5 mH
Stored energy	25 kJ
Cooling	Forced air circulation inside magnet
Conductor mass	~ 450 kg
Total mass (including support frame, shielding, cooling ducts, etc.)	2300 kg

3 CONSTRUCTION DETAILS

The magnet is mounted in two large discs of Al-alloy of 3.6 m diameter with a hexagonal cut-out that act as a general support frame. Stainless steel sheets 2 mm thick and of 890 mm axial width are fixed along the diagonals of the hexagon, and pre-stressed by means of calibrated spring washers to 7 t a sheet. They are constructed in three V-shaped sheets and welded at the centre onto a small star-shaped rod, forming six identical triangular sectors. Detail A of Fig. 3 shows an enlargement of this region.

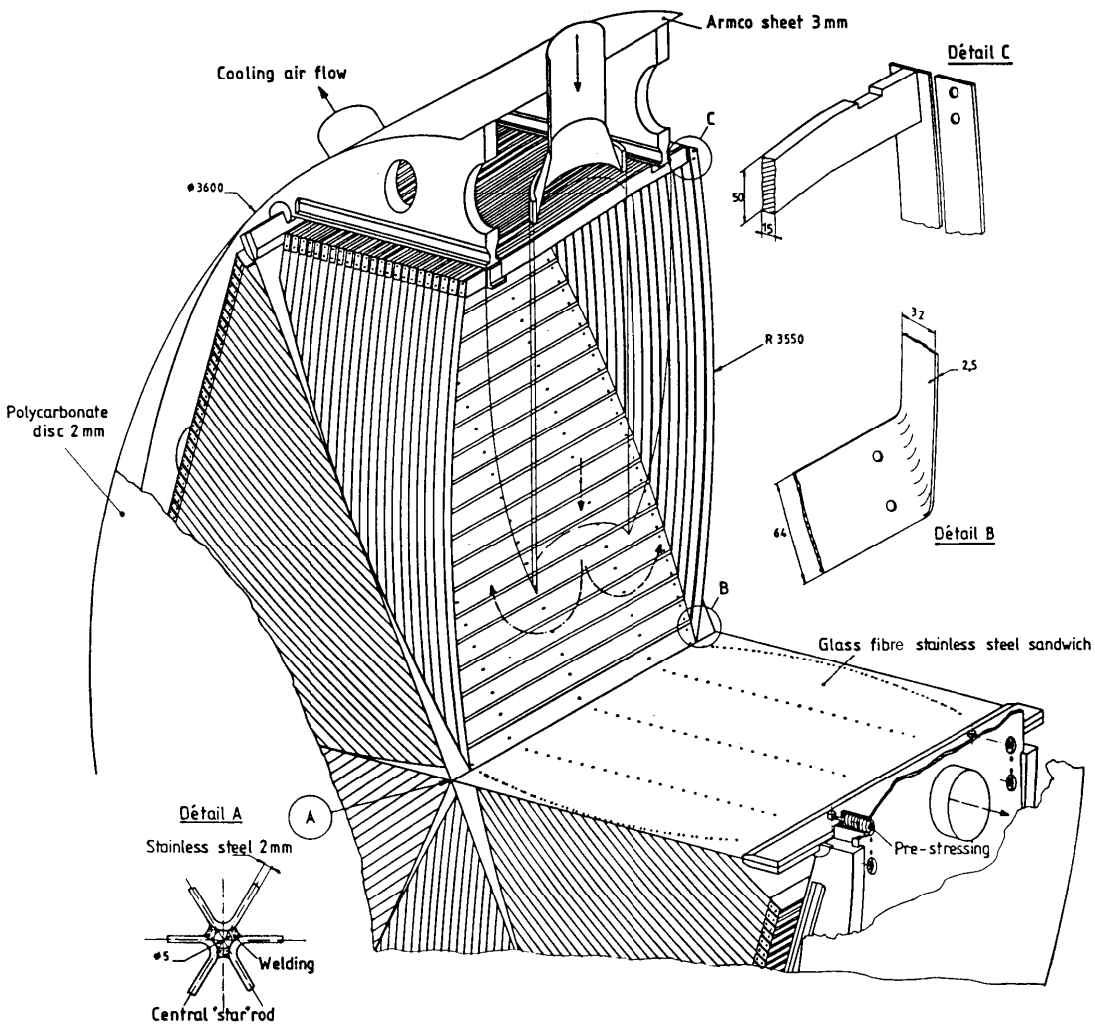

Fig. 3 Details of the conductor and winding arrangement

Both sides of the stainless steel sheets are covered with a 2 mm-thick glass-fibre epoxy plate to build up an insulating sandwich. The conductors of neighbouring triangles are symmetric to the diagonal plane and fixed together onto this insulating sandwich with glass-fibre M8 screws. The conductors and winding arrangement of the magnet are enlarged in Fig. 3.

A conductor is made of a 2.5 mm-thick band of E-Al Mg Si 0.5 (DIN) alloy (trade name: Anticorodal 041), which combines high electric conductivity with good mechanical properties. It is bent in a symmetric U-shape and the two vertical arms of the U form the 32 mm-wide conductor at the front and back face, while the base of the U is given by the 64 mm-wide and tilted part of the conductor, fixed to the insulating sandwich sheet at the diagonal plane (detail B of Fig. 3). Neighbouring U-shaped conductors of one triangular sector of the hexagon are separated by a gap of 2 mm and connected in a series by a solid cross conductor of $50 \times 15 \text{ mm}^2$ at the side of the triangle (detail C of Fig. 3). In this way, all conductors in a triangle form together a solenoid of varying cross section. Neighbouring triangle solenoids are in turn connected in a series to form the total toroid. At the front and back faces an H-shaped rubber profile was inserted into the 2 mm gap between neighbouring conductors in order to

avoid any electrical contact between them during pulsing, and to seal the front and back faces towards the air cooling flow (see Section 4).

The electromagnetic forces which stress and deform the winding when it is pulsed have three contributions. The largest contribution is from the action of the magnetic field on the conductors situated at the front and back faces. At the maximum current of 3200 A the magnetic forces act with a pressure of 0.58 N/cm^2 and bend these conductors towards the outside. The conductors hoop stresses are proportional to the radius of their curvature and lead to a resultant radial force directed outwards, which is supported by the stainless-steel sheet placed in the diagonal planes. The axial part of the U-shaped conductors is pushed by the field with a force having a radial inward component plus a component perpendicular to, and towards, the radial support plane. The total force resulting from these three contributions is up to about 4 t for each radial plane and is directed outwards. The forces acting on the solid cross conductors at the hexagon sides are also directed outwards and absorbed by the supporting structure. Whereas these last forces are easily absorbed without any periodical deformation, the previous forces, due to the thinness of the conductors, produce small elastic deformations during the pulses (see Section 5).

To keep these movements reasonably small and to avoid any asymmetry, the diagonal stainless-steel sheets were spring loaded and pre-stressed with 7 t after compensation of the weight of the inner part of the magnet. For this purpose, the two upper hexagon corners are provided with adjustment devices which permit the magnet geometry to be corrected prior to the pre-stressing by compensating the gravity forces acting on it.

4 PULSING, COOLING AND MONITORING

The requirement of minimal material thickness for traversing particles at a relatively high field with periodically acting forces led to the choice of E–Al Mg Si 0.5 as the conductor material; it has good mechanical properties and its specific resistivity is $30 \text{ m}\Omega \text{ mm}^2/\text{m}$. To assure the quality of the numerous contacts (two for each turn), as is usual for Al conductors all contact surfaces between the U-shaped conductors and the solid cross-bars were gold plated. The resulting total ohmic resistance of the winding is $215 \text{ m}\Omega$.

As stated earlier, the magnet is pulsed in accordance with the neutrino beam, with two pulses spaced by 2.8 s within 14.4 s. The maximum magnetic field has to be stable during the 6-ms period of the neutrino ejection. This was achieved by choosing a flat top of 12 ms for the magnet. Furthermore, to keep the ohmic heat losses as small as possible, the rectifier is pulsed with an over-voltage in order to quickly reach the flat top of the pulse. Thus the pulse overall rise time could be reduced to 50 ms. The fall time is given by the discharge time with a time constant of 30 ms. The effective duty cycle of the magnet is therefore $\sim 0.8\%$ and the corresponding ohmic heat losses are $\sim 17 \text{ kW}$.

Owing to the symmetry the magnetic field is equal in all magnet sectors. It is monitored in three of the sectors by Hall probes read out together with the neutrino data. Figure 4 shows the pulsed magnetic field as seen by one of the probes.

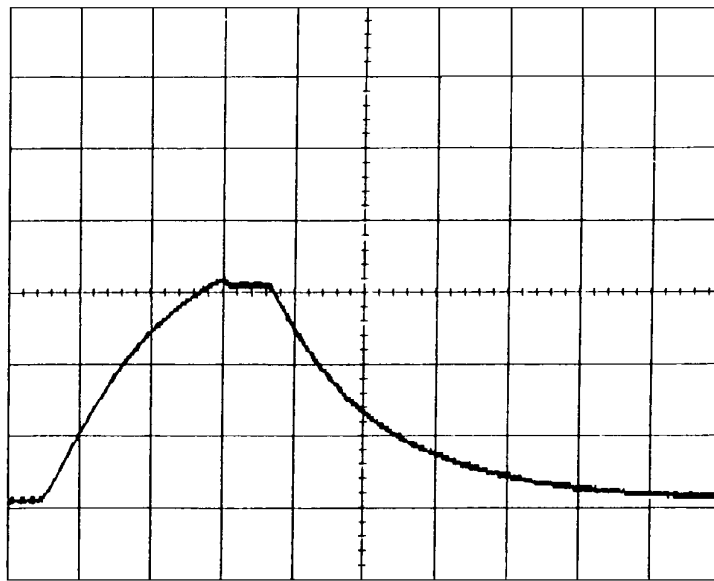

Fig. 4 Hall probe signal of magnetic field pulse,
horizontal scale: 20 ms/div.,
vertical scale: 400 Gauss/div.

The ohmic losses are mainly produced in the thin U-shaped conductors, i.e. in the front and back faces of the magnet and in its radial planes. Owing to the immediate proximity of the fibre tracker planes at both sides of the magnet the cooling by air of the front and back faces can be done only from inside the magnet. Outside these faces, 2 mm-thick polycarbonate discs are fixed to the diagonals and sealed at the ARMCO shielding in order to fully separate thermally the magnet from the detector planes, as indicated in Fig. 3.

The cooling is achieved by a dedicated cooling unit, equipped with a pulsion and extraction fan. It creates a total air flow of $\sim 2 \text{ m}^3/\text{s}$. This air flow is divided into six equal streams, one for each triangular sector. As can be seen from Fig. 3, for each sector the flow of cold air passes the cross conductors with the help of a thin walled polycarbonate tube, is led to its centre and guided with deflector sheets along the inside surfaces. The warm air leaves a sector by passing between the cross conductors in the area not occupied by the inlet tube. It is extracted above each of the six diagonal planes, re-collected, and fed back into the cooling unit without heating up any other part of the detector. To allow for the easy passage of air, the solid cross conductors connecting the thin U-shaped conductors are only 15 mm wide for a centre-to-centre spacing of 34 mm.

When the magnet is pulsed the thin front and back face conductors move under the action of the electromagnetic forces. At a maximum current of 3200 A the centre of the longest conductors will swing outwards by 2 to 2.5 mm. The swing of the shorter conductors is accordingly smaller. The magnet thereby acts as a sound generator, similar to a big drum. For normal operation the measured sound level is 75 dB(A) at a distance of 30 cm from the magnets front face. Its frequency spectrum ranges from about 30 to 250 Hz with a maximum at around 80 Hz. The noise level of the cooling system itself is about 73 dB(A).

To reduce the ageing of nearby CHORUS detector elements (nuclear emulsions and scintillating fibres) and to run the image intensifiers at a lower noise level, the hexagonal magnet is placed together with these elements in a cool box and kept permanently at 5°C . The temperature of the air blown onto the hexagonal magnet is 4°C . Under pulsing conditions the outlet air has a maximum temperature of 10°C .

The maximum instantaneous ohmic loss at full magnet current amounts to ~ 2.2 MW. It is therefore necessary to carefully control the value of the magnet duty cycle and to monitor the magnet temperature. Consequently, thermo-switches and thermistors are fixed onto some of the conductors at the front and back faces of each magnet sector and interlocked with the power supply. The temperature of the longest of these conductors rises under normal pulsing conditions to $\sim 25^\circ\text{C}$. Two series of thermo-switches are provided that open respectively at 60°C and 80°C . On reaching the limiting temperature, the 60°C switches stop the rectifier from pulsing, and the 80°C ones switch off the rectifier supply voltage. Finally, the pulse frequency and the pulse lengths of the rectifier are limited electronically.

5 MATERIAL FATIGUE

The CHORUS experiment will take data during two years of 200 running days each. The magnet pulsed with the neutrino beam will therefore ideally undergo approximately 5×10^6 cycles.

The pulsed magnetic field inside the toroid will periodically deform the thin conductors at the front and back faces. This can lead to rupture of the conductors due to material fatigue. The problem of conductor fatigue has been studied and optimized by finite element analysis and verified experimentally on a number of conductors of shape similar to that in the magnet. The test conductors have been pulsed with current in an external constant magnetic field in order to produce approximately the same stress conditions as in the real pulsed magnet*. The highest risk for material fatigue is in the bent corners of the U-shaped conductors. To reduce this risk, the corners are bent with a inner radius of $R = 6$ mm, and the front and back part of the conductors are pre-formed with a radius of $R = 3550$ mm, as indicated in Fig. 3. This value was chosen as a compromise between the need to limit the stress and the wish to maximize the B·l value in the restricted space. With the above chosen parameters the maximum effective stress at the critical corners can be reduced to ~ 32 N/mm², which is about half the value of 70 N/mm² for 10^7 alternating traction cycles given for this Al-alloy in the material properties table under the ideal conditions of a test specimen.

The hoop stress created by the electromagnetic forces is the same for all front and back face conductors. But in the critical region it produces an elastic deformation proportional to the conductor length — mainly at the bend and its fixation to the diagonal sheet. As a result, the conductors will swing outwards under the magnetic pressure with an amplitude proportional to their length. This swing is 2 to 2.5 mm for the longest conductors. In addition, micro cracks due to the bending, with $R = 6$ mm and opening up under the periodic action of the magnetic pressure cycle, could reduce the theoretical maximum stress value considerably. It is therefore impossible to give a confident number for the probable lifetime under running conditions due to several uncertainties that include: precise fatigue fracture values for this Al-alloy, residual stresses after the bending process, and the elastic behaviour of the entire magnet. One can only say that its lifetime is limited.

* In the real case the stresses are proportional to I^2 , where I is the current in the conductor; in the fatigue tests they were only proportional to I. The maximum stress in the tests was however higher than in the real case.

In order to keep the magnet cycles to a strict minimum the magnet is pulsed only when data are recorded in the CHORUS detector. The magnet has undergone about 1.2×10^6 cycles in the first year of the CHORUS experiment running.

Acknowledgements

The hexagonal magnet is an integral part of the CHORUS detector. We gratefully acknowledge the support of, and the many discussions we had with, our colleagues of the CHORUS Collaboration, and especially with its spokesman K. Winter and its technical coordinator J.P. Fabre.

The realization of the magnet was possible thanks to the skill and dedication of the many people who contributed to its various aspects. In particular we wish to thank K. Mühlemann for help in performing the fatigue test and S. Fahnauer, M. Löbe (both from Humboldt University Berlin) and D. Rotil for their care in preparing the mechanical pieces and in the magnet assembly. B. Danner and his collaborators H. Graskamp, C. Valentini and O. Bohner adapted the magnet current supply for these special pulsing conditions and took care of its functioning. P. Pepinster and P.A. Rochat designed and prepared the magnet's cooling system, and G. Frémont and R. Rey-Mermier supplied the Hall probes for the field measurements and electronics for reading the magnet currents. R. Ferreira, M. de Jong and K. van der Poel incorporated the magnet into the CHORUS trigger and general data acquisition system.

REFERENCES

- [1] Proposal of the CHORUS Collaboration for a new search for neutrino oscillations: CERN-SPSC/90-42 (1990).