

Results on Proton Extraction from the CERN-SPS with a bent Crystal

H. Akbari et al. (RD22 collaboration) ^[1]

presented by K. Elsener
CERN SL-Division, CH-1211 Geneva 23, Switzerland

Abstract

Extraction of protons from a high energy accelerator by means of a bent crystal could be an attractive tool to provide an external beam at hadron colliders. A test experiment at the CERN-SPS, using a 120 GeV coasting proton beam and a 3 cm long bent silicon crystal, has been performed. Diffusion of protons onto the crystal has been created by exciting an electrostatic device with bandlimited white noise. First results showed an extraction efficiency of about 10%. Recent developments using a new crystal with improved geometrical properties are discussed, and future experiments outlined.

1. INTRODUCTION

The possible extraction of high energy proton beams from the future TeV hadron colliders by means of channeling in a bent crystal has been discussed for several years [2,3]. The crystals would be placed in the halo of a circulating beam, and the extraction process be entirely parasitic to collider operation. The space needed for such an extraction is minimal, and the strong fields in the crystal allow deflection angles of the order 1 mrad even at multi-TeV proton energies.

Channeling of high energy protons and beam deflection in bent silicon crystals have been studied in detail at high energy beams, and deflection efficiencies of up to 50% have been found for a parallel beam of 450 GeV protons [4,5]. Extraction experiments using crystals have been successfully performed at lower energies [6,7]. Here, we report on an experiment with a 120 GeV coasting proton beam and a bent silicon crystal at the CERN-SPS. The aim of this experiment is an understanding of the extraction process, its dependence on machine parameters and crystal properties and the measurement of the properties of the extracted beam as well as the extraction efficiency.

2. EXPERIMENT

A schematic view of the experimental arrangement is shown in Fig. 1. Two bent silicon crystals, which can be used alternatively, are installed in a vacuum tank on goniometers allowing the adjustment of the angle of the crystal with the beam. For a first series of measurements, the crystals (shown in Fig. 2) were 18 mm high, 1.5 mm thick and 30 mm long in beam direction, bent on a "Serpukhov-type" bending device [6]. The bend angles are adjusted with a differential screw and are set to be 8.5 mrad. The crystals are cut parallel to the (110) planes with an accuracy better than 200 μ rad, then polished and chemically etched to remove the damage

from the cutting. Finally, the crystals were mechano-chemically polished (Syton technique) to obtain an optically flat surface.

The protons are extracted horizontally towards the center of the SPS and detected 20 m downstream of the crystal (cf. Fig. 1). A scintillating screen (CsI) equipped with a CCD camera is used to get a two dimensional view of the extracted beam on a video screen in the SPS control room. A scintillator hodoscope with 32 horizontal and 32 vertical strips (1 mm wide) is used for monitoring of the beam profiles, while two sets of microstrip gas chambers (MSGC) with a pitch of 200 μ m, placed 1 m apart, are used to measure the divergence and the profiles of the extracted beam. Three scintillation counters are used in coincidence as a trigger for these detectors.

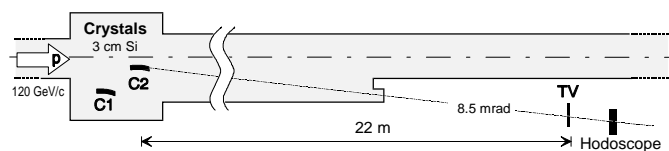

FIGURE 1 : Schematic view of the experimental apparatus used in the SPS extraction experiment with a bent crystal. C1 and C2 are two crystals mounted on goniometers. The detectors for the extracted beam are located 22 meters downstream of the crystals. For details, see text.

For the measurements, a 120 GeV coasting beam with an intensity of about 5.10^{11} protons was used. The SPS shows hardly any non-linear effects at this energy and little natural diffusion, resulting in a beam lifetime of more than hundred hours. The normalized beam emittances (2σ values) are 6-8 mm.mrad horizontally and vertically for an unperturbed beam. The crystal was placed at 10 mm from the closed orbit, corresponding to 6 - 10 times the RMS transverse beam size, where only a few halo particles are found when no noise is applied. The beam is excited horizontally with band limited white noise induced on a pair of condenser plates. Random kicks producing a typical deflection of about 0.001 μ rad (RMS) are applied. The horizontal beam size slowly increases and protons diffuse towards the crystal. The horizontal emittance is typically 60 mm.mrad when the crystal is reached by the particles with large amplitudes, while the vertical emittance remains unchanged (<10 mm.mrad). The statistical nature of this process allows reliable calculations and a simulation of the diffusion process. Mean impact parameters of the protons on the crystal are estimated to be in the micrometer range

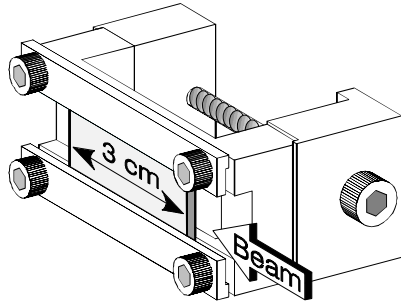

FIGURE 2: The silicon crystal bent on the "Serpukhov type" bending device. The bending is adjusted with a differential screw before mounting in the vacuum tank

3. INITIAL RESULTS

First measurements were performed with bent crystals of the type shown in Fig. 2. The results are reported in detail in ref. [8]. For protons to be channeled and extracted, the crystal has to be aligned with the beam axis to within $\pm 14 \mu\text{rad}$ [4]. It was therefore a surprise to find some extracted beam over an angular range of about $200 \mu\text{rad}$ (FWHM). Moreover, as shown in Fig. 3, the profiles of the extracted beam showed double peaks, when the crystal angle was set to be away from the maximum of extracted beam intensity. Both effects can be qualitatively explained: The mounting of the crystals, as shown in Fig. 2, produces an unwanted curvature in the vertical plane, i.e. transverse to the plane of beam extraction. Moreover, the direction of the (110) planes at both ends of the crystal varies as a function of the vertical position (anticlastic bending). The observed profiles can also be reproduced by simulations [8,9].

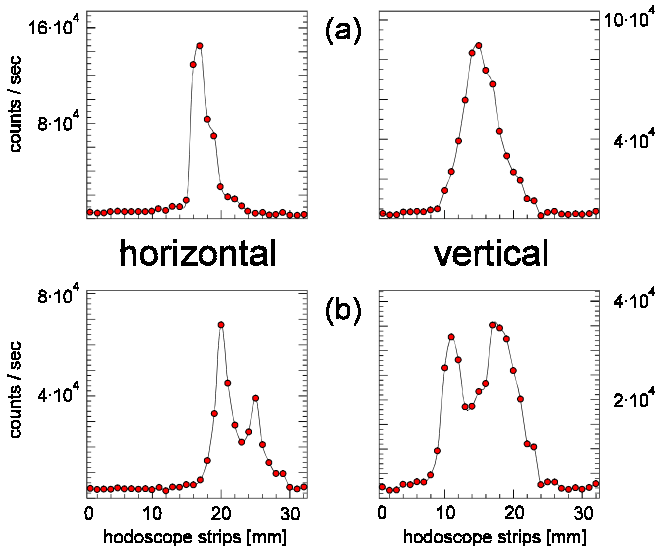

FIGURE 3: Beam profiles of the extracted beam as measured with the hodoscope of scintillation counters, (a) at the maximum extraction efficiency and (b) off-maximum.

In order to measure the extraction efficiency for the optimum crystal alignment, the beam has to reach a "steady state" diffusion mode, i.e. when the extracted beam intensity does not vary with time. The efficiency is determined as the ratio of

protons lost from the SPS for a given time interval. The number of protons in the circulating beam and the proton flux onto the crystal is obtained from intensity monitors and beam lifetime measurements. The rate of protons extracted is determined by integrating the beam profiles measured by the hodoscope after subtracting the background. The combined efficiency of hodoscope and trigger is found to be about 80%.

Typically, for three different crystals of the type shown in Fig. 2, about $6 \cdot 10^5$ protons have been extracted per second, corresponding to an extraction efficiency of about 10%. Further details are given in ref. [8].

4. RECENT RESULTS

Following the measurements with the silicon crystals in the "Serpukhov type" bending devices (Fig. 2), a new crystal was produced and installed in the SPS vacuum. This so called "U-shaped" crystal is shown in Fig. 4. It is cut out of a block of silicon, with "feet" at both ends, allowing to bend the silicon crystal with two differential screws. The stiff ends avoid the unwanted curvature at the entrance and exit faces of the crystal, and careful adjustment of the two screws allows bending to 8.5 mrad without any longitudinal twist. The crystal surface used for extraction is cut parallel to the (110) plane within less than $25 \mu\text{rad}$.

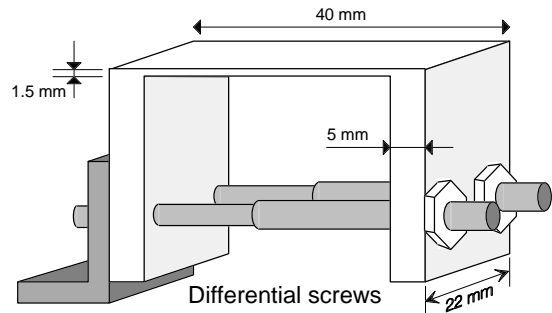

FIGURE 4: Schematic drawing of the new "U-shaped" silicon crystal, cut out of a block of silicon, including the "feet" needed to bend it. Bending is achieved with two differential screws.

First results with this new crystal are encouraging: the angular scans have become considerably narrower (FWHM of $70 \mu\text{rad}$) and the double peaks in the beam profiles have completely disappeared (Fig. 5). The extraction efficiency found is again about 10%. Further experiments will be performed in order to fully explore the properties of this new crystal, and to understand the spurious instabilities in the behavior of the extracted beam profiles and intensities.

5. FUTURE PLANS

The extraction of a 120 GeV proton beam being achieved with a good efficiency, and the initial problems of crystal geometry being solved, it is now essential to address the basic question of the extraction mechanism leading to the observed beam profiles and the 10% extraction efficiency. Basically, two mechanisms are being discussed: first-pass extraction and multi-pass extraction.

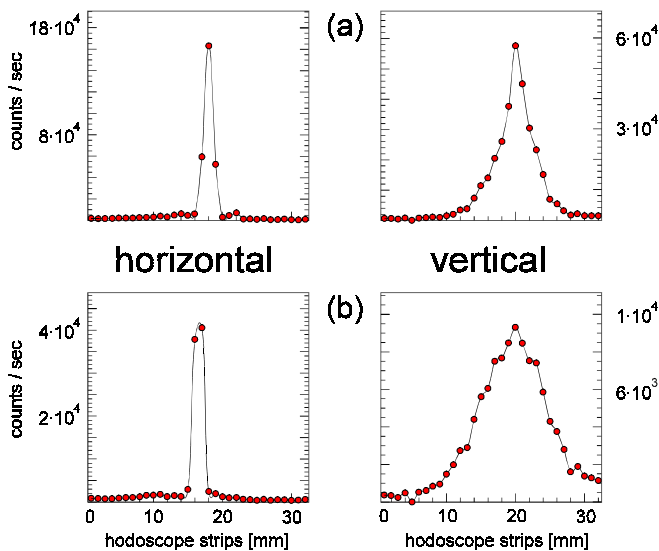

FIGURE 5 : Horizontal and vertical beam profiles measured with the hodoscope for the "U-shaped" crystal, cf. Fig. 3.

First-pass extraction would correspond to the experimental situation in an external beam [4], the only difference being the small impact parameters of the protons onto the crystal, thus the importance of the surface quality (see Fig. 6). Note that an efficiency of about 40% would be expected for pure first-pass extraction and a perfect crystal surface.

Multi-pass extraction is inherent to the situation in a circular accelerator: protons which are not channeled during the first passage of the crystal will undergo multiple scattering, usually with small angles, and will thus have "further chances" at later turns to be channeled and extracted when passing the crystal inside the critical angle for channeling. This extraction mechanism has been predicted and may be inferred from some of the observations in the present experiment – no direct experimental proof for the existence of multi-pass extraction has yet been found.

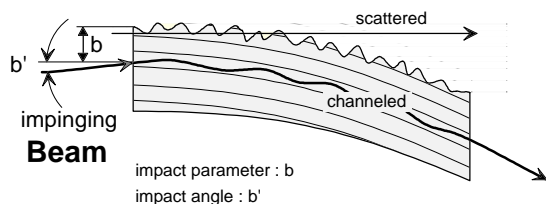

FIGURE 6 : Importance of the surface quality for first-pass channeling and extraction.

Very recently, another crystal has been installed in the SPS vacuum tank. It is a crystal bent as shown in Fig. 2, which had already been successfully used in this experiment to extract protons. Now, an amorphous silicon oxide layer of about 30 μm thickness has been evaporated onto the crystal surface used for extraction. Therefore, given the small impact parameters of typically 1 μm in our experiment, this crystal would not be useful for first-pass extraction. Hopefully in the

near future, an experiment with this crystal should show whether multi-pass extraction exists and what is its relative contribution to the extraction efficiency of 10% observed earlier.

Apart from the possibly larger extraction efficiency [10,11], the importance of multi-pass extraction would be two-fold. First, the size of the impact parameters of the protons becomes irrelevant: multiple scattering will occur whenever the protons reach the crystal. Therefore, for a prediction of the extraction probability with a bent crystal at future accelerators, a detailed knowledge of the diffusion mechanism would no longer be important, and no artificial control of the diffusion would be needed. Second, the requirements on the crystal surface quality become less stringent – the surface is used as a scatterer rather than for channeling and extraction.

Finally, simulations have shown that the machine optics can be adapted in order to optimize the multi-pass extraction efficiency: for a given tune value Q , an optimal β can be found [11]. Clearly, once multi-pass extraction is established, this would be the next step to pursue experimentally.

6. CONCLUSIONS

The first experiments on proton extraction from the CERN-SPS with a bent crystal have been successful. An efficiency of about 10% has been regularly achieved. For a more detailed understanding and further optimization of the extraction process, the first hardware changes have been made: a crystal with an amorphous layer should allow a measurement of the contributions from multi-pass extraction. More experiments and simulations will be needed in order to study the feasibility of extracting beam with a crystal from LHC or other high energy accelerators.

7. REFERENCES

- [1] H. Akbari, X. Altuna, S. Bardin, V. Biryukov, B. Dehning, K. Elsener, G.F. Ferioli, A. Ferrari, G.P. Ferri, G. Fidecaro, R. Guinand, M. Gyr, W. Herr, A. Hilaire, J. Klem, V. Mertens, S. Péraire, M. Placidi, W. Scandale, R. Schmidt, B. Vettermann, E. Weisse, S. Weisz, S.P. Møller, E. Uggerhøj, A. Freund, R. Hustache, A. Calcaterra, R de Sangro, O. Palamara, R. Bellazzini, A. Brez, G. Carboni, F. Costantini, M.M. Massai, P.F. Vita, F. Ferroni, S. Morganti, R. Santacesaria, M.P. Bussa, L. Busso, F. Tosello, L. Lanceri, G. Vuagnin and K. Maier.
- [2] R.A. Carrigan et al., *Nucl Instr Meth* **B48** (1990) 167.
- [3] W. Scandale, Experimental insertion for the LHC, in: Large Hadron Collider Workshop (Aachen, 1990), CERN 90-10, ECFA 90-133, Vol. III, p. 760.
- [4] S.P. Møller et al., *Nucl. Instr. Meth.* **B84** (1994) 434, and references therein.
- [5] K. Elsener et al., *these proceedings*.
- [6] A.A. Asseev et al., *Nucl. Instr. Meth.* **A330** (1993), 39.
- [7] A.A. Asseev and E.A. Myae, *these proceedings*.
- [8] H. Akbari et al., *Phys. Lett.* **B313** (1993) 491.
- [9] V. Biryukov, *these proceedings*.
- [10] A.M. Taratin et al., *Nucl. Instr. Meth.* **B58** (1991) 103.
- [11] W. Herr, CERN SL/92-53 and S. Bardin, SL/Note 92-52 (AP).