

CRITICAL ISSUES IN MUON COLLIDERS - A SUMMARY

S. Chattopadhyay, W. Barletta, S. Maury,** D. Neuffer,***
A. Ruggiero,**** A. Sessler*

Lawrence Berkeley Laboratory, University of California,
Berkeley, CA 94720, USA

ABSTRACT

We present a brief summary of the current state of conception and understanding of high-energy muon colliders, associated technological challenges and future research directions on this topic.

1. MOTIVATION AND CHALLENGES

It is well known that multi-TeV e^+e^- colliders are constrained in energy, luminosity and resolution, being limited by "radiative effects" which scale inversely as the fourth power of the lepton mass $[(E/m_e)^4]$. Thus collisions using heavier leptons such as muons offer a potentially easier extension to higher energies [1]. It is also believed that the muons have a much greater direct coupling into the mass-generating "Higgs-sector", which is the acknowledged next frontier to be explored in particle physics. This leads us to the consideration of TeV-scale $\mu^+\mu^-$ colliders. However, with the experimental determination of the top quark being heavier than the Z boson, there is increasing possibility of the existence of a "light" Higgs particle with a mass value bracketed by the Z-boson mass and twice that value. This makes a 100 GeV $\mu^+ \otimes 100$ GeV μ^- collider as "Higgs Factory" an attractive option. The required luminosity is determined to be $10^{30} \text{ cm}^{-2}\text{s}^{-1}$. We note that the required luminosity for the same "physics reach" scales inversely as the square of the lepton mass and implies a significantly higher luminosity required of a similar energy e^+e^- collider, in order to reach the same physics goals.

The challenges associated with developing a muon collider were discussed at the Port Jefferson workshop [1, 2], subsequent mini-workshops at Napa [3], Los Alamos [4] and at the present workshop [5, 6]. Basically, the two inter-related fundamental aspects about muons that critically determine and limit the design and development of a muon collider are that muons are secondary particles and that they have a rather short lifetime in the rest frame. The muon lifetime is about 2.2 μsec at rest and is dilated to about 2.2 msec at 100 GeV in the laboratory frame by the relativistic effect. The dilated lifetime is short enough to pose significant challenges to fast beam manipulation and control. Being secondary particles with short lifetime, muons are not to be found in abundance in nature, but rather have to be created in collisions with heavy nuclear targets. Muon beams produced from such heavy targets have spot size and divergence-limited intrinsic phase-space density which is rather low. To achieve the required luminosity, one needs to cool the beams in phase space by several orders of magnitude. And all these processes - production, cooling, other bunch manipulations, acceleration and eventual transport to collision point - will have to be completed fast in 1-2 ms and there lies the challenge. Bunch manipulation and cooling of phase space are some of the primary concerns. In the following section, we describe the two scenarios, and associated parameters being considered at present for muon colliders.

2. SCENARIOS, PARAMETERS AND COMMENTS

Basically, there are two scenarios that have been considered to date for muon colliders. These two scenarios start with very different approaches to the production of the secondary muon beam from a primary beam hitting a heavy target. The subsequent acceleration, cooling, stacking, bunching and colliding gymnastics are all dictated and differentiated by these production schemes, which are very different. We consider them in sequence in the following.

* Reporting author.

** CERN, CH-1211 Geneva 23, Switzerland.

*** CEBAF, 12000 Jefferson Ave., Newport News, VA 23606, USA.

**** BNL, Upton New York 11973, USA.

The first approach considers production of the muons starting from a primary "proton" beam hitting a heavy target according to the following reaction:

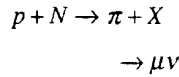

Since proton bunches are typically long (few ns), one basically obtains long bunches of low phase-space density, unless further phase-space manipulations are done to bunch and cool the beams. The situation is similar to the use of the Proton Ring as a pion source in the Los Alamos Meson Physics Facility (LAMPF-II) or conventionally considered kaon factory sources, for example. In order to reduce the length of the produced muon beam bunches, considerable gymnastics is required of the proton ring rf system. Ultimately, of course, a bunch rotation in the longitudinal phase space to reduce bunch length comes at the expense of the relative momentum spread, $(\Delta p/p)$, which could be as high as 5%. The produced muon bunches will need to be cooled longitudinally from $(\Delta p/p)$ of 5% to about 0.1% in order to have acceptable spectral purity at the collision point. In addition, the muon bunches will have to be cooled in the transverse phase space by a significant amount in order to meet the luminosity demand at the collision point. The cooled muons are subsequently accelerated and injected into a 100 GeV $\mu^+ \mu^-$ collider where the bunches collide in at most a few hundred to a thousand turns (the number of turns, $n = 300 \bar{B}$ [Tesla]). Clearly the constraint of short muon lifetime puts a premium at every stage on minimizing the time for production, cooling, acceleration and bunch processing, so as to still leave a few hundred turns in the collider to produce luminosity. Thus, it is clear that high field magnets play crucial role in the collider. Details of this scenario have been considered by D. Neuffer [5]. In Fig. 1, we depict schematically the scenario of a muon collider based on production via protons [5].

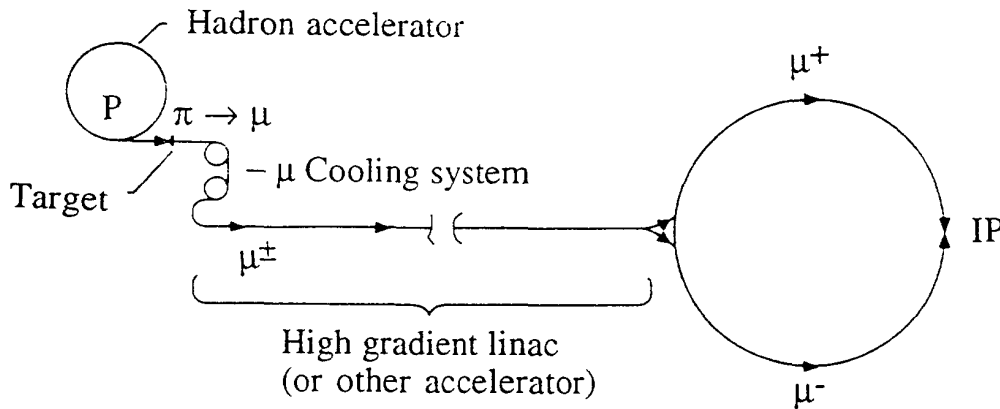
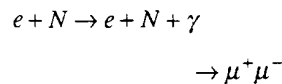

Fig. 1 - Overview of a $\mu^+ \mu^-$ collider, showing a hadronic accelerator, which produces π 's on a target, followed by a μ -decay channel ($\pi \rightarrow \mu \nu$) and μ -cooling system, followed by a μ -accelerating linac (or recirculating linac or rapid-cycling synchrotron), feeding into a high-energy storage ring for $\mu^+ \mu^-$ collisions. (from Ref. [5])

A second approach considers production of the muons starting from a primary "electron" beam hitting a heavy target according to the following reaction:



In this electro-production scenario, one obtains short bunches most naturally, since it is compatible with the normal mode of operation of high energy linacs. Although one obtains the "optimum bunch format" naturally, one has to consider unprecedentedly high power and high repetition rate electron linacs, not explored before in order to meet the required collision luminosity. This is so because of the rather low yield of muons per electron, even at the optimum energy of incident electrons of 60 GeV, and the difficulty of packing more electrons per bunch in the linac. The low transverse phase-space density of the muons will require significant improvement via cooling, similar to the proton production scenario, and, in addition, calls for a non-trivial beam stacking scheme before collision described in Ref. [6]. Details of this scenario have been considered by Barletta and Sessler [6]. In Fig. 2, we depict schematically the scenario of a muon collider based on electro-production [6].

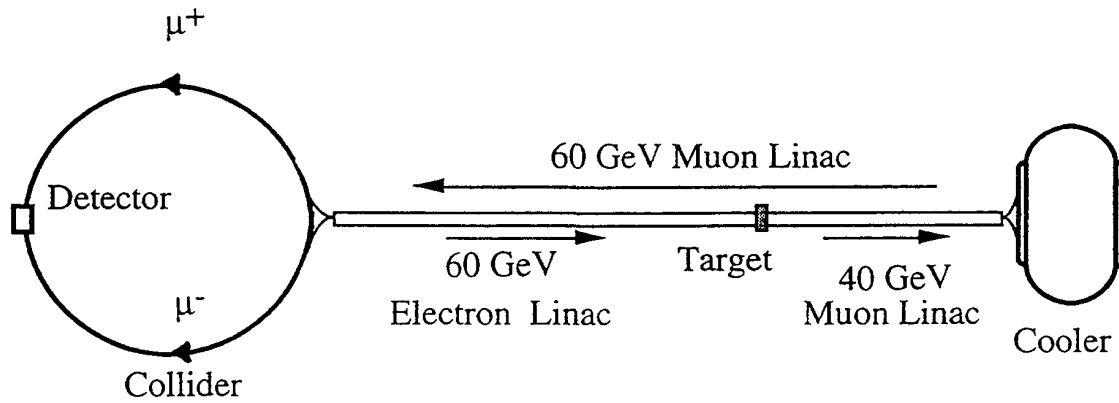

Fig. 2 - A muon collider scenario with electro-production of muons. (from Ref. [6])

Table 1 presents a comparison of parameters for the above two scenarios for a 100 GeV $\mu^+ \otimes 100$ GeV μ^- collider, with an average luminosity of 10^{30} cm $^{-2}$ s $^{-1}$. We assumed a collider scenario with a low beta at the collision point of 1 cm, about 1 000 bunches colliding in the ring and muon production limited by a 5 MW power at the target. It is clear that while powerful pion sources, bunch compression and cooling are essential for the proton-production scenario, high current electron linacs, cooling and stacking are essential for the electro-production scenario. It is fair to say from an inspection of Table 1 that, fundamentally, both scenarios are equally amenable to a muon collider configuration with comparable luminosities, given the fact that in both cases equally difficult and challenging technological problems will have to be addressed and solved.

Table 1 - Parameters for a muon collider

100 GeV \otimes 100 GeV

$$L = M \frac{N_+ N_- f}{4 \pi \epsilon_N \beta^*} \gamma \sim 10^{30} \text{ cm}^{-2} \text{ s}^{-1}$$

$M = 1\ 000$; $\gamma = 1\ 000$; $\beta^* = 1$ cm; $P = 5$ MW @ target

	Production via Electrons	Production via Protons
$E_{e \text{ or } p}$ (GeV)	60	30
Intensity	5×10^{11} /pulse	10^{14} /pulse
# pulses	100 (stacked later)	1
Repetition rate (Hz)	10	10
E_μ (GeV)	40	1.5
ϵ_N (π m-rad)	2×10^{-3}	2×10^{-2}
$\Delta p/p$	$\pm 3\%$	$\pm 3\%$
(μ/e) or (μ/p)	4×10^{-3}	10^{-3}
Ionisation cooling	$\epsilon_n^f = 2 \times 10^{-5} \pi$ m-rad	$\epsilon_n^f = 2 \times 10^{-5} \pi$ m-rad
Bunch Rotation Factor	None	100

The most difficult and challenging of these technological problems is probably that of "ultra-rapid" phase-space cooling of "intense" bunches. One can consider radiation cooling via synchrotron radiation which is independent of the bunch intensity. However, it is too slow for our purposes. Stochastic cooling rate, on the other hand, depends on the number of particles per bunch and, although too slow usually, can be made significantly faster by going to an extreme scenario of a few particles per bunch with ultra-fast phase mixing or

an ultra-high bandwidth ($\sim 10^{14}$ Hz) cooling feedback loop. Both the latter cases will require significant technological inventions. A promising scheme that is both "fast" and "intensity-independent" is that of "Ionization Cooling", which looks feasible in principle. We have assumed ionization cooling in arriving at the parameters of Table 1. We discuss cooling considerations briefly in the next section.

3. COOLING OF MUONS

The cooling of the transverse phase-space assumed in Table 1 is of the kind known as "Ionization Cooling". In this scheme the beam transverse and longitudinal energy losses in passing through a material medium are followed by coherent reacceleration, resulting in beam phase-space cooling [5-7]. The cooling rate achievable is much faster than, although similar conceptually to, radiation damping in a storage ring in which energy losses in synchrotron radiation followed by rf acceleration result in beam phase-space cooling in all dimensions. Ionization cooling is described in great detail in Ref. [5] in these proceedings. It seems that the time is ripe to make a serious design of an ionization cooling channel, including the associated magnetic optics and rf aspects, and put it to real test at some laboratory.

Exploration of the alternate cooling scheme of stochastic cooling takes us to a totally different regime of operation of the collider, determined by the very different nature and mechanism of cooling by an electronic feedback system. Here, the muon lifetime and the required low emittance demanded by the luminosity requirements determine the necessary stochastic cooling rate of the phase space. This rate scales directly as the bandwidth (W) of the feedback system and inversely as the number of particles (N) in the beam (stochastic cooling rate $\propto W/N$). If we limit our consideration to practically achievable conventional feedback electronics, amplifiers, etc. with bandwidth not exceeding 10 GHz, the number of particles per bunch must be less than a thousand (1 000) in order to meet the desired rate. This then would imply a very different pulse format. This alone drives all the parameters back to the source and issues of "targetry" and "muon source", etc. are not critical. The critical issues for stochastic cooling are: (1) large bandwidth, (2) ultra-low noise, as the cooled emittance reaches the thermal limit of the electronics, (3) rapid mixing and (4) bunch recombination techniques.

Critical issues in the stochastic cooling scenario are discussed by Ruggiero [8], where he also explores a conventional cooling scheme with modest bandwidth but with a special non-linear (magnetic) device that stirs up the phase space rapidly and provides "ultra-fast mixing". It is clear that we need new technical inventions in stochastic cooling for application in a muon collider. Another novel scheme [9] being explored currently is that of "optical cooling" where one detects the granularity of phase space down to a micron scale by carefully monitoring the incoherent radiation from the beam, which is a measure of its Schottky noise, then amplifying this radiation via a laser amplifier of high gain and bandwidth (10^7 , 100 THz) and applying it back to the beam. Various issues regarding quantum noise and effective pickup and kicker mechanisms will have to be understood before it can be considered for a serious design.

4. SUMMARY AND OUTLOOK

As we have seen, both scenarios - production of muons from protons and electro-production of muons - are competitive but very ambitious and challenging. Production of muons from protons will clearly require non-trivial and sophisticated target design and configuration. In addition, in order to match the bunch length of the colliding (but secondarily produced) muon beams to the low-beta function at the collision point, the primary proton beams must be bunched by a large factor (~ 100). The complicated bunch rotation and rf manipulations are cumbersome and must be done at the low-energy proton end before the target, which implies an associated increase in the relative momentum spread, ($\Delta p/p$). On a positive note, however, targetry with protons and rf gymnastics with proton beams are relatively familiar affairs at hadron and kaon facilities, albeit at a lower level of power and rf manipulation of the bunches. Electro-production of muons, on the other hand, requires high-peak current, high-repetition rate linacs, so far unexplored, in order to meet the luminosity demand. Besides, "stacking" of many electron bunches from a linac into a single bunch poses a non-trivial problem. The significant and most attractive feature of the electro-production scenario, however, is that the "optimal pulse format" is produced directly at the target by electrons from a linac, without complex bunch compression schemes in a ring.

No matter what the optimal scenario would turn out to be, should the muon collider concept turn into reality, further consideration of such a collider at 200 GeV center-of-mass energy with an average luminosity of $\sim 10^{30}$ cm⁻²s⁻¹ would have to assume major advances in an eventual operation of: (1) megawatt muon targets, (2) multi-kiloampere peak current electron linacs, (3) efficient transfer, compression and stacking schemes for charged particle beams, (4) high-field magnets and (5) most importantly, feasible phase-space cooling technologies with low noise and large bandwidth. While "Ionization Cooling" looks promising, it needs experimental demonstration. A possible feasibility test of muon production and ionization cooling at existing facilities, e.g., CERN, FNAL, etc. would be highly desirable. The "stochastic Cooling" approach, however, would need fundamental invention of a new technique, as elaborated earlier. The emerging new ideas of "Optical Stochastic Cooling", "Ultra-rapid Phase-Mixer", etc. are ambitious, but may hold the key to the success of such

high-frequency stochastic cooling. Finally, the synchrotron radiation and muon decay in the collider ring vacuum chamber and detector area pose issues that cannot be overlooked.

In conclusion, surely a muon collider is exotic! But even as we contemplate the value, utility and eventual realizability of such a collider in future, there is no doubt that the necessary conceptual and technological explorations forced upon us by these considerations are much too valuable to many fields to be simply passed up.

ACKNOWLEDGEMENTS

This work was supported by the Director, Office of Energy Research, Office of High Energy and Nuclear Physics, High Energy Physics Division, of the US Department of Energy under contract No. DE-AC03-76SF00098.

REFERENCES

- [1] M. Tigner, in *Advanced Accelerator Concepts*, Port Jefferson, NY 1992, AIP Conf. Proc. 279, 1 (1993).
- [2] P. Chen and K.T. Mac Donald, in AIP Conf. Proc. 279, 853 (1993).
- [3] Proceedings of the Mini-workshop on $\mu^+ - \mu^-$ Colliders: Particle Physics and Design, Napa, CA, to be published in Nucl. Inst. and Meth. A (1993).
- [4] Proceedings of the Muon Collider Workshop, February 1993, Los Alamos National Laboratory Report LA-UR-93-866 (1993).
- [5] D. Neuffer, *Muon Cooling and Applications*, these Workshop Proceedings.
- [6] W.A. Barletta and A.M. Sessler, *Prospects for High Energy Muon Collider Based On Electro-production*, these Workshop Proceedings.
- [7] D. Neuffer, *Particle Accelerators*, 14, 75 (1983).
- [8] A.G. Ruggiero, *Stochastic Cooling Requirements for a Muon Collider*, these Workshop Proceedings.
- [9] A.A. Mikhailichenko and M.S. Zolotarev, *Optical Stochastic Cooling*, SLAC-PUB-6272, July 1993.