

PAPER • OPEN ACCESS

Life cycle environmental and cost evaluation of heating and hot water supply in social housing nZEBs

To cite this article: P Hernandez *et al* 2019 *IOP Conf. Ser.: Earth Environ. Sci.* **323** 012162

View the [article online](#) for updates and enhancements.

Life cycle environmental and cost evaluation of heating and hot water supply in social housing nZEBs

Hernandez P¹, Hernandez J¹, Urra I¹, Grisaleña D²

¹ TECNALIA Research & Innovation, Astondo Bidea, Edificio 700, Derio, 48160 Spain

² VISESA, Basque Country Public Housing Body, Portal de Gamarra 1A, 01013, Vitoria-Gasteiz, Spain

patxi.hernandez@tecnalia.com

Abstract. This paper presents a comparative analysis of different space heating and hot water systems for a social housing project in Santurtzi, Spain. The building, comprising 32 apartment units and currently under construction, has been designed to minimize thermal energy demand, while ensuring comfort and quality of the internal environment for the social housing occupiers. The selection of the heating and hot water energy systems has been carried considering a life cycle perspective both for environmental and economic impacts. Different alternatives have been analysed which compare conventional gas boiler installation, which has been the norm for this type of social housing for the last decades, with various options based on heat pump technology. Life cycle analysis of the environmental effects of electrification of the thermal energy demand through heat pumps show a potential for reducing life cycle CO₂ emissions. The economic evaluation done through life cycle costing, comparing investment, maintenance, replacement and operational costs of gas boiler with aérothermal and geothermal heat pump solutions, have shown however that gas heating solutions are still the most competitive economically. Increasing the overall efficiency of those heating and hot water systems that include heat pump technology, while reducing their uncertainty in operation is a key element to ensure competitiveness of heat pumps in the current market.

1. Introduction

In the last decades heating and hot water for residential buildings, and in particular for social housing, has been increasingly supplied in the Basque Country by the use of natural gas. Current construction standards, with reduced thermal energy demand, provide the opportunity to explore solutions that move away from natural gas, for example by electrification of thermal supply through the use of heat pumps. With a vision for an electricity mix that will progressively reduce its environmental impacts by utilising a larger share of renewable generation, and the potential for on-site renewable electricity generation which is becoming very affordable (mainly through PV panels), use of heat pumps is expected to grow in the coming years.

This paper studies alternatives for electrification of thermal energy loads through heat pumps in a case study of a nearly-Zero Energy Building, with particular attention to the evaluation of life cycle environmental and economic performance of different design alternatives for the installations.



2. Case Study

Alternative technologies for heating and hot water are studied in a new residential building, for social renting use, being VISESA the building developer (Basque Country Public Housing Body). The building is situated in Santurtzi (Bizkaia, North of Spain), with a temperate climate (Köppen-Geiger climate classification Cfb) and 1,023 Heating Degree Days (15 degree base temperature). It comprises 32 apartments in four floors, with a total of 2885 m² of useful floor area, and a North-South orientation. Construction is expected to be finished within autumn 2019.

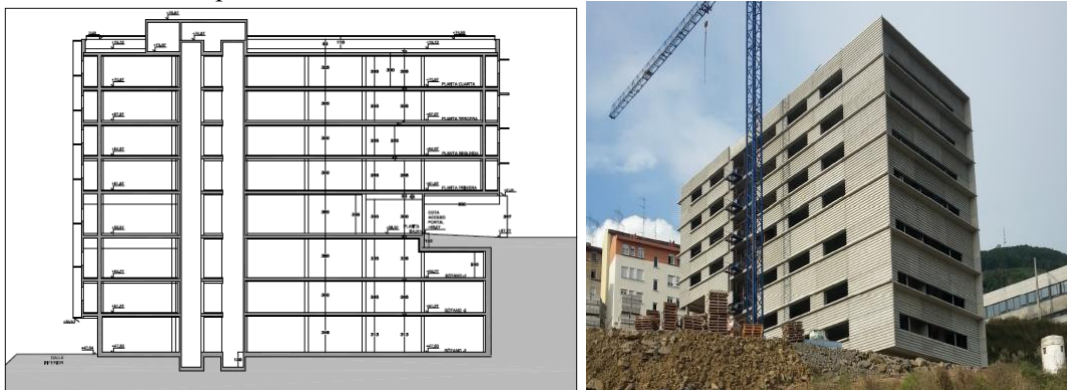

Figure 1. Section of the apartment building and current state of construction (December 2018).

The building has been designed to meet high energy – efficiency standards, beyond current building regulations in Spain, and even beyond future building regulations which are currently published as a draft, which is expected to require non-renewable primary energy use below 32 kWh/ m²·year, for new residential buildings in this location [1]. This is possible with a detailed design to reduce infiltration and thermal bridging, installation of mechanical ventilation with heat recovery, and the following thermal characteristics (transmittance U-values) for the building envelope:

- Windows: 1,20 W/m²·K (Low emissivity, Argon filled, 4/16/3+3)
- Façade: 0,23 W/ m²·K
- Roof: 0,21 W/ m²·K

Calculated heating demand for a building of such characteristics in this climate is consequently very low, just 6 kWh/m²·year, below the expected hot water demand which is 12 kWh/ m²·year. No cooling systems are installed in residential buildings in this climate, as cooling demand is very low and natural ventilation, particularly night ventilation, is used to achieve comfort.

These low energy demands provide the opportunity to reconsider how energy supply is approached in buildings, as one of the main benefits of the gas supply, which is its ability to supply a large and instant power base, might not be longer needed for low energy buildings with correspondingly low peak power demands. Different options for utilization of heat pumps in this building have been therefore studied.

3. Different choices of energy systems for heating and DHW

Table 1 describes the different energy systems that have been considered for the building, which combine the use of the heat pump technology with different heat sources (air, ground, and mixed).

Table 1. Energy systems for heating and DHW considered in this study

	Installed Power	Efficiency
1- GAS + SOLAR (CENTRAL)	2 * 50 kW	102% (condensing boiler)
2- AIR-TO-WATER HEAT PUMP (CENTRAL)	2 * 47 kW	SCOP = 2,5

3- AIR TO WATER + GEOTHERMAL HEAT PUMPS (CENTRAL)	2 * 47 kW	SCOP = 3
4- GEOTHERMAL HEAT PUMPS (CENTRAL)	2 * 47 kW	SCOP = 4
5- AIR-TO-WATER HEAT PUMPS (INDIVIDUAL)	32 * 7 kW	SCOP = 2,5

Detailed design was carried for each of the options, with installation detail and budgeting as shown in Figure 2 as an example. Options 1, 2, 3 and 4 are centralized installations where heat is centrally generated and distributed to the 32 apartments. Option 5 refers to individual installations in each apartment.

The option 1 with gas, includes a solar thermal installation with 14 panels of 2.52 m² each, which covers 32% of the annual hot water demand, as this is requisite from the building regulations to comply with a minimum renewable energy contribution. Option 2 is an air to water heat pump, and option 4 a geothermal heat pump. Option 3 is a mixed solution which can combine both geothermal and air source heat pumps, depending on the temperature of the heat source (external air or ground). For all the heat pump cases, and with the estimated seasonal coefficients of performance (SCOPs) shown in Table 1, the requirements for contribution of renewable energy from current building regulations in Spain are fulfilled, as renewable energy from heat pumps is accounted as set out in the Renewable Energy Directive [2]. However, it is important to note that these SCOP values have a relatively large degree of uncertainty. The performance of the heat pump will depend on the performance of the actual installation, which includes various storage and buffer tanks (see figure 2), numerous pumps and heat exchangers, and a control logic that will be programmed. Real efficiency in operation will depend on the variations of both the heat source temperature (external air or ground) and the heating and hot water demands. Values for the seasonal performance of the heat pumps, which are provided by the manufacturers according to standard testing procedures such as EN 14825 [3], need therefore to be adjusted to real performance within this specific installation and expected demands. The values shown in Table 1 depart from the calculations made with the Spanish HULC energy certification tool [4], further adjusted for particularities which the software is not able to model, for example the losses through the different distribution and storage systems.

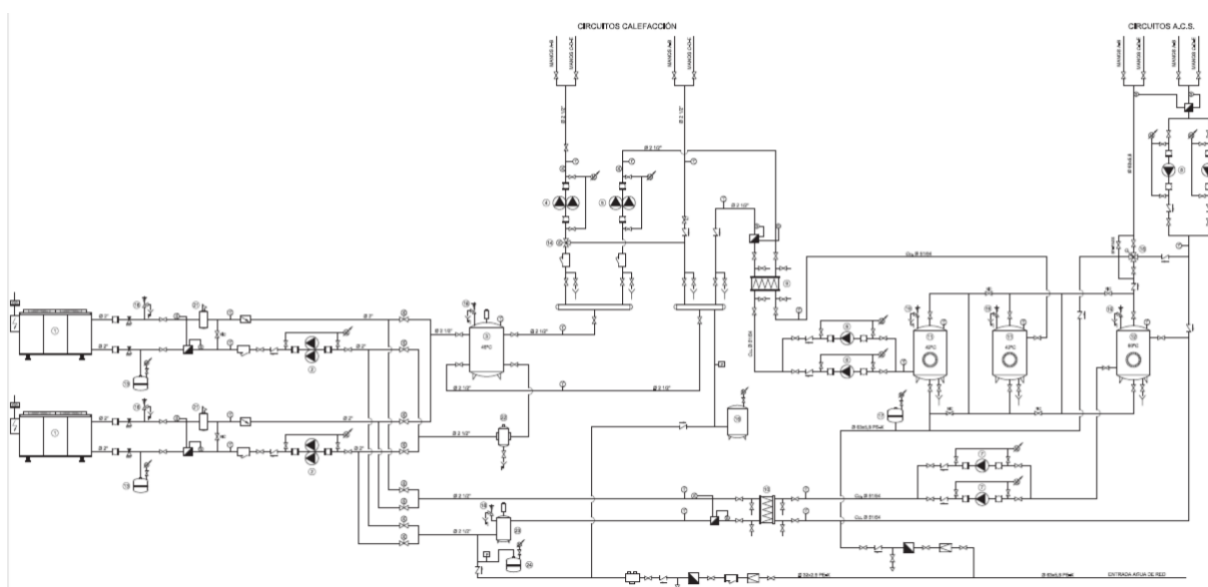

Figure 2. Diagram of the Option 2, air-to-water heat pump centralized installation

From these estimations about the energy performance of the different energy systems, heating and hot water final energy use for the building has been calculated and is presented in Table 2. This table does not add auxiliary energy use, which is very similar as core distribution system, which is quite standard in this type of buildings, has been maintained for all options.

Once the energy use of the different options has been calculated, in order to assess economic and environmental performance of the heating and hot water system from a life cycle perspective, these results should be combined with the data on environmental and cost evaluation of other life cycle phases, such as the product manufacturing and installation, and the maintenance phases.

Table 2. Energy use for space heating and DHW for the different technologies.

	Gas [kWh/year]	Electricity [kWh/year]
1-GAS + SOLAR - CENTRAL	64701	0
2-AIR-TO-WATER HEAT PUMP - CENTRAL	0	36355
3-AIR TO WATER + GEOTHERMAL HEAT PUMPS – CENTRAL	0	30926
4-GEOTHERMAL HEAT PUMPS - CENTRAL	0	22722
5-AIR-TO-WATER HEAT PUMPS - INDIVIDUAL	0	30355

4. Results for life cycle environmental and economic performance evaluation

This study intends to serve as an example on how decisions on energy systems can take into account a life cycle perspective, and facilitate selection of options that have favorable economic performance over a period of study considering the whole life cycle cost, even if they correspond to different actors through that period (i.e.: building developer, building owner, building occupier/user).

Environmental and economic performance of the five technology options for heating and hot water supply have been evaluated from a life cycle perspective, following standard 'EN 15978:2011 – Sustainability of construction works – Assessment of environmental performance of buildings – Calculation methods for environmental evaluation' [5], and standard 'EN 16627:2015 – Sustainability of construction works – Assessment of economic performance of buildings – Calculation methods for the economic evaluation' [6]. Evaluation considers the impacts of the products (manufacturing of the systems), on site installation processes, and the use stage (including operation and maintenance). End on life stage, as its impact is relatively very low for building energy installations, has been disregarded for this study. The study period for the assessment has been selected as 15 years, which is the expected service life for some of the key products in the analysis (such as the heat pumps).

The functional unit for the analysis has been selected as 1 kWh of heat delivered to the dwellings, for heating and domestic hot water. The environmental impacts and economic costs of delivering 1 kWh are quantified in the following sections.

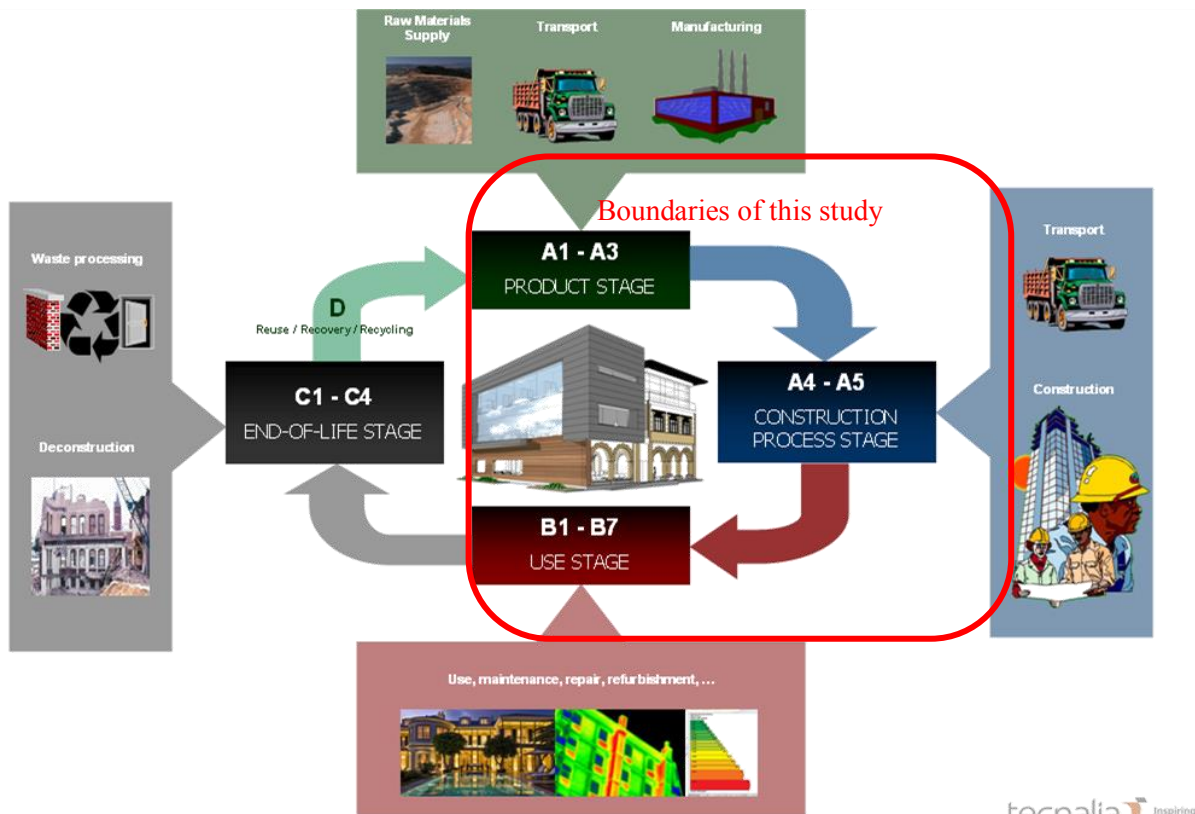

Figure 3. Description of the life cycle stages within EN 15978 and boundaries set for this study

4.1 Environmental performance evaluation

The Ecoinvent LCA database [7] has been used to attribute environmental impacts to the different products that conform the different installations, such as the gas boiler, solar panels, heat pumps, geothermal bore holes, storage tanks, etc.; as well as for the impacts related to electricity and gas usage. Different environmental indicators can be calculated according to EN 15978. Figure 4 shows the results for the global warming potential indicator.

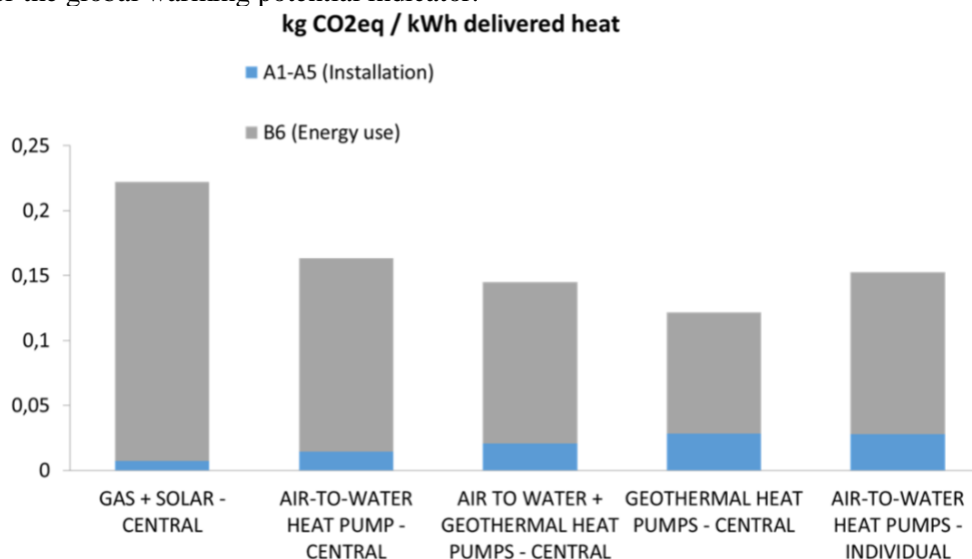

Figure 4. Global warming potential of delivered heat by the different energy systems

It can be observed that the main environmental impact is related, as it could be expected, to the actual energy usage in the operation stage (B6), and that the impact of the product stage (A1-A5) is relatively low. The solutions with heat pumps, even with the current electricity mix (which has been considered constant for the 15 years study period), are favorable to the heat pumps. Results range from 121 to 163 grams of CO₂eq per delivered kWh of heat delivered by the different solutions with heat pumps, compared to 222 grams of the conventional solution of gas boiler with solar water heating support.

4.2 Economic performance evaluation

To quantify the cost indicators over the study period, it is necessary to develop some scenarios and make certain assumptions on a few variables. This study considers a real discount rate of 3%, and conservative annual increases on prices of electricity of 0,5%, and 1% for gas. Costs of the different options are disaggregated and shown in table 3 (production and installations costs), and table 4 (maintenance costs).

Table 3. Cost of product and installation stages (A1-A5) for the different technologies

	1 -GAS + SOLAR	2- AEROT CENTRAL	3- GEOT+AEROT - CENTRAL	4- GEOT CENTRAL	5-AEROT – INDIVIDUAL
Total Generation + Distribución:					
Heating & DHW	72.504,25 €	111.757,47 €	155.190,39 €	165.446,00 €	247.898,59 €
Legal procedures	1.171,88 €	1.115,53 €	1.115,00 €	1.115,00 €	1.143,71 €
Generation and boiler room	27.453,93 €	69.347,62 €	71.866,81 €	70.089,00 €	237.920,00 €
Regulation and control	14.311,96 €	33.175,48 €	25.870,74 €	20.765,00 €	8.834,88 €
General distribution (not including internal for each apartment)	8.832,44 €	8.118,84 €	8.118,84 €	8.118,00 €	
Solar installation	20.734,04 €				
Bore holes			39.533,00 €	56.400,00 €	
Thermal Response Testing (TRT) & commissioning			8.686,00 €	8.959,00 €	

Table 4. Cost of maintenance stage (B2) for the different technologies

	Annual maintenance costs [kWh/year]
1-GAS + SOLAR - CENTRAL	1,700 €/year
2-AIR-TO-WATER HEAT PUMP - CENTRAL	1,700 €/year
3-AIR TO WATER + GEOTHERMAL HEAT PUMPS – CENTRAL	1,500 €/year
4-GEOTHERMAL HEAT PUMPS - CENTRAL	1,000 €/year
5-AIR-TO-WATER HEAT PUMPS - INDIVIDUAL	2,560 €/year

Operational energy costs are more complex to calculate. For centralized heat pump installations, the costs for contracting electricity power capacity for different time periods during the day need to be considered. For geothermal installations, lower contracted power is one of the economic advantages, as due to the more constant temperature of the ground used as heat source, a good coefficient of performance (COP) is maintained even in cold periods. On the contrary, air source heat pumps lower their efficiency during periods with low external temperatures, and therefore need to draw more power from electricity grid to deliver the necessary heat supply. Centralized installation with air to water heat pump need to contract an estimated power of 45kW for the peak power periods, compared to 25kW

contracted power for centralized geothermal heat pump installations. As for individual heat pump installations, each apartment would need to contract additional power capacity, which has been estimated as additional 3kW, which largely increase the fixed costs of the operation for the users. Gas installations do have the advantage of very low fixed costs. Figure 4 shows results of the overall operational costs for the considered options, showing fixed costs and variable (energy) costs, for each delivered kWh of heat.

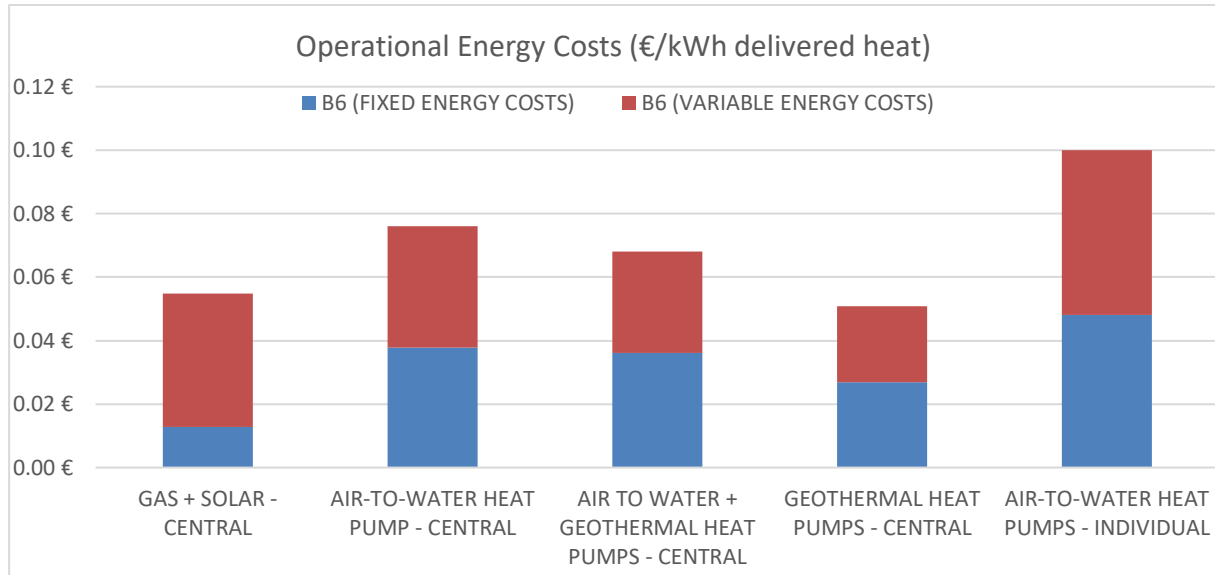

Figure 5. Operational energy costs for the different energy systems.

It can be observed that the low fixed costs of the gas installations make them a very interesting option from an operational energy cost perspective, only after the centralized geothermal installation. Individual heat pumps, due to both variable and fixed costs, are the most expensive solution in this case.

To be able to compare all the technologies for the selected study period of 15 years, costs of the other life cycle stages need to be added to the operational energy costs. Figure 6 shows the results of adding the initial costs for the installation and maintenance costs for the five technological options considered in this study.

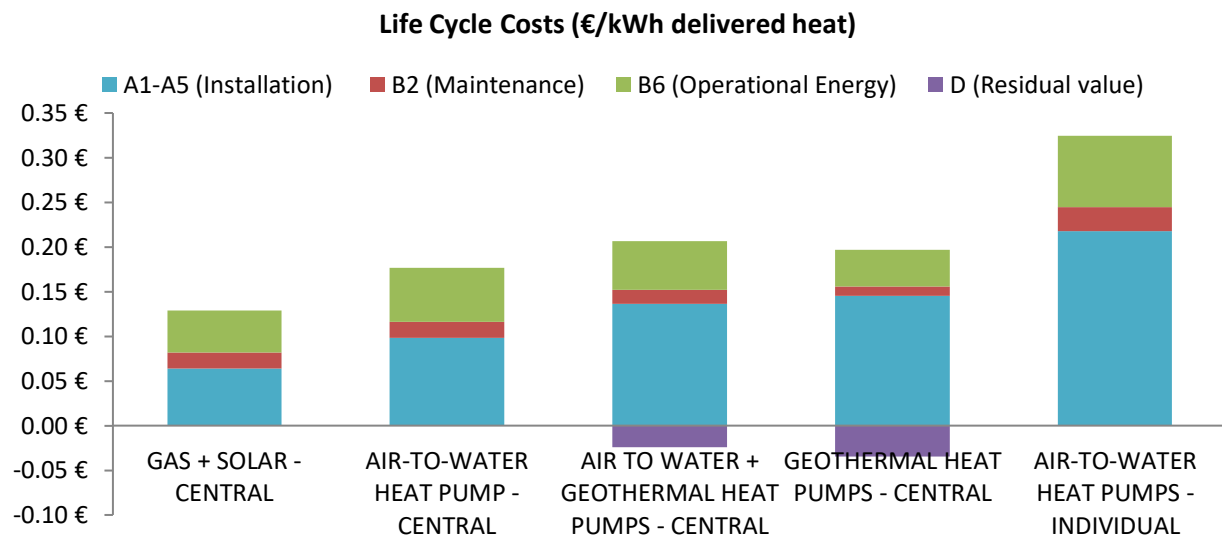

Figure 6. Life cycle costs for the different energy systems considered in the study. Residual value considering value of components (particularly geothermal borehole) after the 15 year study period.

Due to the lower initial investment and a competitive operational cost, gas installations backed with solar water heating systems are currently the most economically favourable solution for this case study building.

Geothermal installations offer the lowest operational costs in energy, and the lowest cost for the users considering also maintenance, but larger initial investment costs mean that overall life cycle costs are higher than both gas and air to water centralized installations. It must be noted that if we would consider the residual value of the borehole in geothermal installation, as will have an estimated service life of 50 years, much larger than the study period of 15 years, life cycle cost results would be similar to air to water centralized heat pump installations.

Air to water individual installations are the most expensive solution for this building within all cost categories (installation, maintenance, and operation).

5. Discussion and conclusions

The building sector is aiming for a progressive reduction of the energy use, and decarbonisation of the energy supply. A first step to achieve this goal is the drastic reduction of the energy needs for buildings, and a second step should be the study of the optimal technologies and energy systems to supply those energy needs.

This study has compared solutions for heat pump installations which could substitute the common gas installation, in a 32-apartment building designed for very low energy use for heating and hot water.

Most of the life cycle impacts of delivering heat to the building occur during the operation phase due to the energy use. Even for a building as the studied with very low energy use in operation, the manufacturing and installation of the actual heating energy systems represents a relatively small percentage of the total life cycle environmental impacts. Only for geothermal installations, where significant environmental impacts occur in the installation mostly due to the borehole drilling, and for the individual heat pump installations, the share of total life cycle CO₂ emissions that can be attributed to the manufacturing and installation of the systems is above 10%.

Total life cycle CO₂ emissions have shown that natural gas, which has been frequently cited as a 'low-carbon' and 'transition' fuel and is still the most common heating fuel in Spain, has larger CO₂ emissions than alternative solutions based on heat pump technology, even with the current electricity mix.

Studying life cycle costs for the presented technology options, for a period of study of 15 years and including costs for investment, operation and maintenance, gives however a very different result. The gas installation, which is backed with a solar water heating system, is still the most cost-efficient option for providing heating and hot water to the case study building. The low initial investment, and operational energy costs only challenged by the most efficient geothermal heat pump solutions, means that solely in cost terms it is still difficult to compete with this standard solution. Comparing within the heat pumps, centralized air to water heat pumps is the most competitive, mainly because lower initial investment. If the period of study will be extended (e.g. 50 years), geothermal solutions could become competitive in cost terms, as their major investment cost (borehole heat exchanger) has a service life of 50 years. Individual heat pumps are the most expensive option, due to higher initial investment and higher operational costs, in part due to higher needs for contracting electricity power for the apartment occupiers.

As a final conclusion, heat pumps can be a good solution to reduce CO₂ emissions, particularly as they offer the possibility of using increasingly renewable electricity, also from on-site renewable energy sources. Although economically they still have strong competition from the gas energy supply, overall life cycle costs are close and could be matched in the near future. Improving the overall performance of heat pump installations in operation will be of key importance to reduce life cycle costs of heat delivered by heat pumps. The large sources of uncertainty that were found when calculating seasonal performance of installations using heat pump technology, also highlighted the need for thorough

commissioning, measurement and verification procedures for buildings including heat pump technology, procedures which have already been implemented in the described case study building.

Acknowledgements

The work presented in this article is part of an analysis carried within AZEB project ‘Affordable Zero Energy Buildings’, which has received funding from the European Union’s Horizon 2020 research and innovation programme under grant agreement No 754174.

References

- [1] Ministry of Development of Spain (2018) , Annex I to Building Regulations CTE Document for energy savings 2018.
- [2] DIRECTIVE (EU) 2018/2001 OF THE EUROPEAN PARLIAMENT AND OF THE COUNCIL of 11 December 2018 , on the promotion of the use of energy from renewable sources (recast)
- [3] EUROPEAN COMMITTEE FOR STANDARDIZATION (2016),EN 14825:2016 Air conditioners, liquid chilling packages and heat pumps, with electrically driven compressors, for space heating and cooling. Testing and rating at part load conditions and calculation of seasonal performance
- [4] HULC (2016). Unified tool LIDER-CALENER, version 1.0.1493.1049 [Herramienta unificada LIDER-CALENER, versión 1.0.1493.1049]. Available at: <http://www.codigotecnico.org/>
- [5] EUROPEAN COMMITTEE FOR STANDARDIZATION (2011), EN 15978:2011 – Sustainability of construction works – Assessment of environmental performance of buildings – Calculation methods for environmental evaluation,
- [6] EUROPEAN COMMITTEE FOR STANDARDIZATION (2015),EN 16627:2015 – Sustainability of construction works – Assessment of economic performance of buildings
- [7] Wernet, G., Bauer, C., Steubing, B., Reinhard, J., Moreno-Ruiz, E., and Weidema, B., 2016. The ecoinvent database version 3 (part I): overview and methodology. *The International Journal of Life Cycle Assessment*21(9), pp.1218–1230.