

## WINDING PROBLEMS WITH ROTOGRAVURE JUMBO-ROLLS

E. G. Welp

Jagenberg AG

Geschäftsbereich Maschinenbau

Düsseldorf, Germany

### ABSTRACT

The production and conversion of jumbo rolls presents a challenge to all involved in the production process. This presentation shows that as reel dimensions continue to increase, limits are being reached with regard to engineering and production. This applies to the paper, the core and particularly to winders and printing machine unwinds. The two problems areas, on the one hand crepe wrinkles and bursts in the reel centre when rewinding and unwinding and on the other hand the danger of the core disintegrating in the winder machine unwind, which can have serious consequences, can only be solved jointly by those involved in the whole process. One effective measure will be to use 150 mm cores instead of the 76 mm core for extremely heavy jumbo reels. This will represent an initial decisive breakthrough to improve the situation. Further optimisation in paper making and converting, in core geometry, strength and stiffness as well as in the design of winders and printing machine unwinds will ensure that the manufacture and conversion of jumbo reels meet the requirements posed.

### THE REQUIREMENTS OF THE PRINTING INDUSTRY

The development of machine winders is considerably influenced by the requirements of the printing and paper industries. Besides improving the printability and runability of the paper, printers are also interested in increasing the productivity of their printing machines. Productivity is measured according to the output of printed paper, whereby the speed of the printing machine, its working width, and the paper length stored on each paper reel are the related parameters.

Higher productivity can thus be achieved by having reels which are bigger in diameter and width, which can be processed at higher speeds.

For rotogravure papers (types SC and LWC), which we are concerned with in this instance, the speed of today's printing machines is 12.5 m/s. The printing industry's declared aim is to attain speeds of 14 m/s. With reference to working

width, machines which are 3.08 m wide are currently in operation in central Europe. Machines of 3.18 m width are being designed, and there are projects underway for machines with a width of 3.60 m.

Reel diameters are increasing both for SC and LWC papers. Printer's statistics indicate that over a period of five years, the average diameter of reels has increased at about 8-10 cm to 120 cm. The aim for reel diameters is 130 cm and over. Reels with these dimensions result in reel weights at about 6-8 tonnes, and for papers with a lower basis weight, in rewound web lengths of over 30,000 m.

## **THE ESSENTIAL TECHNICAL REQUIREMENTS FOR MANUFACTURING JUMBO REELS**

To be able to produce big reels (jumbo reels) with top printability at a high rate of productivity, stringent requirements have to be met with regard to the wind structure of the reels. A good wind structure can be recognised by the following:

- the dimensional stability of the reel
- the stress-strain properties of the wound paper layers

The dimensional stability of a reel can be seen from its cylindrical form, smooth face ends, stability for transport and absence of telescoping and after-shrinkage. The stress-strain properties of the wound layers determines the runability in the printing machine. Stress-strain properties are good when web deformations which occur during unwinding and rewinding do not put excess strain on the elasticity of the paper, which means that there is no stretching or damage to the wound layers.

If during printing a good register in length and cross direction is to be achieved, the elasticity and evenness of the stress-strain properties across the entire reel diameter is vital.

We will now go on to discuss the production of jumbo reels in the light of these essential technical requirements.

## **WINDERS FOR THE PRODUCTION OF JUMBO REELS**

When producing jumbo reels from rotogravure papers on traditional two-drum winders, it was recognised at an early stage that this machine principle was subject to certain physical limitations. The reel weight is distributed onto both winder drums with this winding principle and, as this weight increases, the permissible, specific nip pressure at the contact points (i.e. in the nip) between the reel and the winder drums is exceeded. This leads to overstretching and finally to bursting of the outer paper layers and reduced paper surface quality. This limitation of the two-drum winder principle was the catalyst for the development of winders working according to the centre drum winding principle.

### The Centre Drum Principle and its Winding Parameters

Winding machines which work in accordance with the centre drum principle are characterised by individual winding stations. Each winding station is equipped with individual drive, control and regulating units.

This enables individual influencing of the winding structure of each reel in a set. The result of this is, that it is possible, to process reels with differing diameters, widths and core diameters. Working from the basic principle, several designs were developed by the winder producers, such as those in Figure 1.

The paper industry's requirements of these machines are:

- Maximum productivity due to high machine speeds and short down times.
- Automised handling and operation of the machine with low personnel requirements.
- Controlled fault free winding structure - even with the largest reel dimensions.

Without going into more precise details of machine technology, there are basic differences in the productivity and in the automised handling and operation of the differing machines.

For a controlled fault free winding structure the following technical winding parameters are available in centre drum winders:

- Web tension between unwind and rewind, nip pressures, torque at reel periphery and torque at the core.

These winding parameters can be extremely finely adjusted using computerised control and regulating systems.

With correct selection of winding parameters and through the optimisation of these parameters, it is possible to wind rotogravure paper reels with reel widths at about 2.5 m and reel diameters at about 120 cm (at a reel weight at about 4 tonnes) so that there are no defects in terms of dimension stability of the reels and also in terms of winding structure. In processing reels with dimensions and weights in excess of these limits, winding defects may well occur. These defects occur not only on the winder itself but also on the printing machine unwind. It is apparent that in these instances too, the physical limitations of rewinding and unwinding have been reached.

It is against this backdrop that we must examine the following trial results which can lead to the eradication of winding problems on jumbo reels.

## **PROCESSING PROBLEMS WITH JUMBO REELS AND THEIR IMPACT**

When processing jumbo reels with extreme reel dimensions, various problems can occur during rewinding on centre drum winders and unwinding on printing machine unwinds. These problems are caused by the fact that during both rewinding and unwinding the reels are shaftlessly taken up only with expanding core chucks inserted into the cores on both sides. This means that the whole reel weight is supported on these relatively short expanding core chucks - half on either side (approximately 120 mm on winders and approximately 180 mm on printing machine unwinds). Furthermore, driving torques are induced into the cores during rewinding and breaking torques during unwinding.

This basic situation can lead to overloading of

- the core chucks, the core and the reel centre (paper layers near the core).

Damage to the expanding core chucks can only be prevented by using cores with a larger diameter (e.g. 150 mm as opposed to 76 mm cores) when certain reel weights are exceeded, in order that a larger expanding core chuck cross section is available for the alternating bending load. Overloading of the cores can be seen through scoring of the core caused by the reel weight and the induced torque.

Moreover, when unwinding very wide reels (larger at about 2.5 m) on printing machine unwinds, cores with a small outer diameter (76 mm cores) and the remaining layers of paper can reach critical speeds and this can lead to breakages. This problem can only be solved using cores of a larger diameter (e.g. 150 mm), with a higher stiffness, a smaller mass and a higher tensile strength.

The overloading of the reel centre in the core chuck area usually results in serious damage to the reel.

- Crepe wrinkles and bursts near the core and in the core chuck area occur.

This damage is difficult to recognise. The reason for this is that the damaged layers are not always recognised by visually checking the reels during their formation and once they are finished. Only when the damaged layers project axially out of the face end of the reel can damage be identified. They have serious consequences for subsequent processing, like for example in the printing machine. If the reel were unwound down to the damaged layers, this would inevitably cause a web break in the printing machine. In order to avoid this problem, reels are today spliced above the critical reel core diameter of 135-150 mm. Despite intensive research, it has still not been possible to clearly diagnose the formation process and physical cause for reel defects in the form of crepe wrinkles and bursts in the area of the core.

One thing is certain, however: the reel defects in the winder occur when a large reel weight has been reached, in other words at the end of winding and not at the beginning. The same is true of printing machine unwinds. Defects occur when unwinding begins at large reel weight.

#### Analysis of Reel Defects at the Core

The mere appearance of crepe wrinkles and bursts indicates that they are caused by a complex of stressing factors and layer slippage. One of our aims in this analysis is to explain the occurrence of stressing and layer slippage around the core.

Our analysis starts with the examination of specific core loading during the rewind and unwind process. Figure 2 shows specific core loading as a function of the reel diameter on a printing machine unwind (curve A), and a single-drum winder unwind (curve C), in comparison to the specific core loading of the reel weight (curve B).

Specific core loading is proportional to reel weight, namely quadratic as the reel diameter increases. Specific core loading is considerably higher at the printing machine unwind (about 70 % higher for large reel diameters) than at the rewind of the single-drum winder. This is because, in addition to reel weight, the cores on printing machine unwinds are also subject to load from the brake belts. On single-drum winders, the reel weight is supported by the winder drum, which diminishes

core loading. This comparison enables one result to be established. On account of higher core loading, and consequently increased stressing of the layers around the core, stressing and layer slippage at printing machine unwinds is greater than on winders.

For more precise definition of stressing and layer slippage at the reel core, the characteristics for bending moment, shearing force and core deflection must be identified. In Figure 3, these characteristics are shown as a function of the reel width.

The results show, that the greatest bending moment and shearing force, and thus the greatest deflection of the core, occurs at the area near the core chucks. In the middle of the reel width however, there is only minimal exertion of these forces. On very tightly wound reels, the bending moment in this area is fully compensated by the axial support offered by the reel itself. This means that in this case the core is free of shearing forces and deflection.

Having established correlations, it is possible to draw conclusions regarding the stressing of paper layers near the core. Figure 4 shows stressing in the roll centre. It can be seen that at the end of the core chucks, there is tri-axial stressing at the core which is also exerted on the paper layers immediately around it, i.e. radial, tangential and axial stressing. At the middle of the reel, radial and tangential stressing is exerted. On account of the transverse force characteristic, the maximum stressing of the paper layers takes place at the end of the core chucks.

At the same time, the stressing undergoes changes with each revolution of the reel.

From this explanation, a second analysis result can be deduced. Stress peaks in the paper layers can only occur in the core chuck area and cause paper tear-outs or bursts when borderline stress is exceeded. Furthermore, the bending of the core in the core chuck area can indicate eccentricity of the core vis-a-vis the reel axis. The eccentric position of the core makes the paper layers near to the core subject to layer slippage. This means that the layer slippage occurs when the reel centre circles the reel axis with the dimension of eccentricity  $e$ .

In order to better understand and analyse this cinematic of layer slippage, reel centres were wound and experimentally tested in a specially built trial stand. This trial stand largely permits simulation of the actual process in a large reel. To do this reel centres, which have been cut off down to the length of the core chuck, are put into the testing rig and can be statically and dynamically loaded. The reel centre is taken up in a circular shell, which simulates the radial stress conditions of a large reel. Furthermore the circular shell and the drive shaft from the core chuck are coupled, so that a relatively movement in rotational direction is not possible.

In a first static trial, the reel centre was loaded with a radial force in the centre as per Figure 5, to determine the change in the radial stressing. As a result of this measurement, the change in the winding hardness (determined by the Smith needle test), which characterizes the radial stress, was drawn in a diagram.

The winding hardness at the periphery of the reel centre shows that the winding hardness is strongly increased in the area where the radial force exerts pressure and strongly reduced in the relief area. Another very important result was deduced from these trials. Under radial stress, a reel centre do not distort homogenously like an elastic body, but instead we get slab-shaped rings in the relief area, which are separated from each other by a gap. This means that although the layers in this gap are under tangential stress, but they are completely free of radial

stress. The degree of slab formation depends on the paper parameters compressibility and smoothness. In the borderline, the thickness of the slabs can be reduced to 1 paper layer thickness.

If one subjects the reel centre to a rotational movement whilst keeping the radial force, the slabs or individual layers are twisted against each other. It is very simple to make this layer slippage visible on the face end of the reel centre. Before starting the trial, a radial marking line is applied to the core chuck, to the core, reel centre and shell. When the reel centre and shell are set in rotational motion, with a motor drive on the drive shaft from the core chuck, the marking line on the face end of the reel centre turns in peripheral direction. In Figures 6 & 7 the results of these trials are shown qualitatively.

The illustrations show the layer slippage depending on the winding direction. Figure 6 shows the behaviour in rewind direction, Figure 7 in unwind direction. In both cases it can be seen that individual layers (case 1) or also slabs (case 2) are always shifted in winding direction near to the core. The extent of slippage depends on paper parameters, on the winding hardness in the reel centre, on the radial force and the number of rotations.

These findings allow the mechanics of layer slippage to be understood and appraised. However, it must be added that during the actual winding process of a jumbo reel, layer slippage does not occur in this exaggerated form. The reason for this is that the layers in question in the reel centre area are not shifted, no slab formation, no core eccentricity, see Figure 5 and therefore prevent layer slippage in the core chuck area.

Many important findings result from these investigations although they only simulate the actual winding process.

At this point some results which are of intrinsic importance where the occurrence of crepe wrinkles and bursts in the reel centre is concerned.

- Crepe wrinkles and bursts can only occur in connection with layer slippage.
- Crepe wrinkles or bursts usually involve one or a few layers.
- Crepe wrinkles and bursts only occur when there is sudden layer slippage between individual layers or slabs; if the slippage is minor or continuous, no crepe wrinkles or bursts occur.
- In rewind direction crepe wrinkles usually occur. As a result of the crepe wrinkle formation, occasional bursts can occur.
- In unwind direction the tendency is towards bursts. As a result of the bursts, occasional crepe wrinkles can occur.
- Paper parameters such as: specific density, compressibility, smoothness and cross profile influence the formation of crepe wrinkles and bursts.
- Core parameters such as: geometry, strength, stiffness and surface elasticity also have an influence on the formation of crepe wrinkles and bursts.

The experimental analysis results shown here were confirmed by varying many parameters and by reproduced trials. Representative for these trials are the photographed face ends of reel centres with layer slippage shown in Figure 8 The LWC paper used for the trial shows a tendency towards slab formation. The illustration shows the rewind and unwind cases respectively.

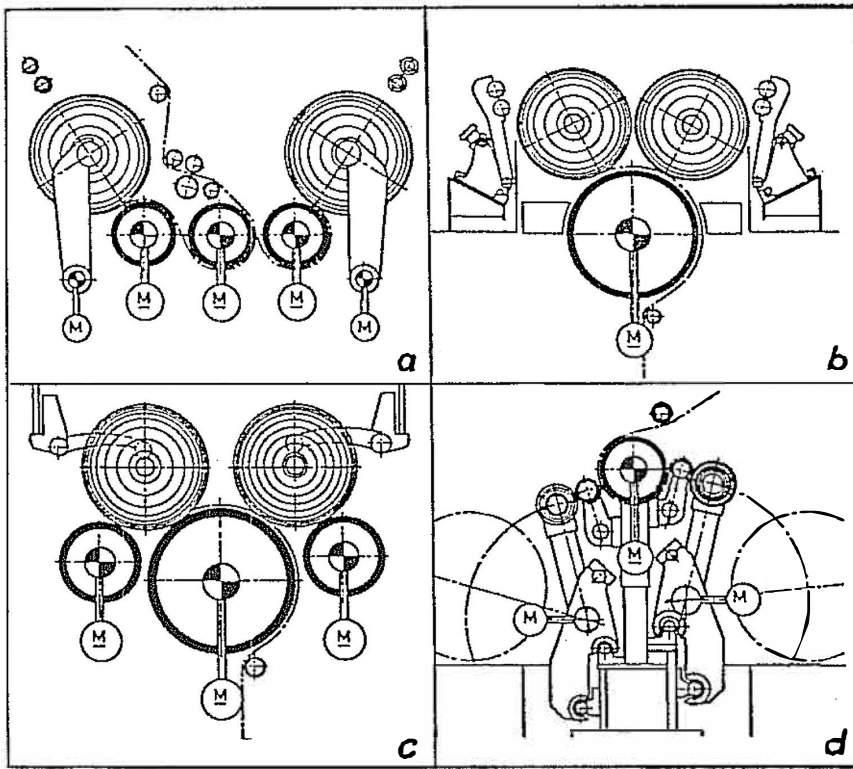
## **APPLYING THE RESULTS OF THE ANALYSIS TO THE MANUFACTURE OF LARGE REELS**

Winders and/or printing machine unwinds both participate in reel defects in the form of crepe wrinkles and bursts in the reel centre, if the defects can not be attributed to paper and core influences. If crepe wrinkles mainly occur in connection with the occasional burst, the likelihood is that the winder is at fault; on the other hand if mainly bursts occur in connection with a small amount of wrinkling, it is likely to be the printing machine unwind or the unwind of a re-reeler in the paper mill. Inadequate rewinding and unwinding is usually the cause of crepe wrinkles and bursts.

As crepe wrinkles and bursts do not occur until the final diameter is reached during rewinding and at the beginning of unwinding (in other words when the maximum reel weight is effective) rather than in the rewinding or unwinding phase of the reel centre, care must be taken that the reel weight is counterloaded. In the case of centre drum winders, this requirement is met by supporting a major portion of the weight on the centre drum and in this way the core and paper layers close to it are less stressed. This is not the case where printing machine unwinds are concerned. On the contrary, core and the paper layers in the reel centre are subject to additional load over and above the reel weight due to the brake belts applied from above. This problem in the unwind can only be eliminated by applying the brake belts underneath the reel so that they have a counterloading effect.

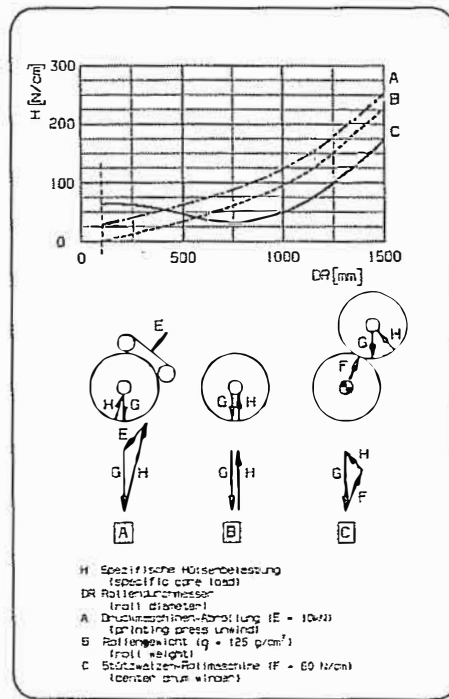
Defect-free manufacture of large reels on centre drum winders depends to a large extent on the control and regulation of the winding parameters. The winding parameters must be set in such a way that optimum winding hardness and layer slippage are achieved depending on the paper grade in question.

This means that the setting of the winding parameters and their joint effect should be adapted individually to each paper grade. Winding strategies must be found which assume a high degree of knowledge and experience in the winding of jumbo reels composed of rotogravure paper. Figure 9 is a general comment on the effect of the winding parameters and the paper parameters on winding hardness and layer slippage. It also indicates the aim for good winding structure.

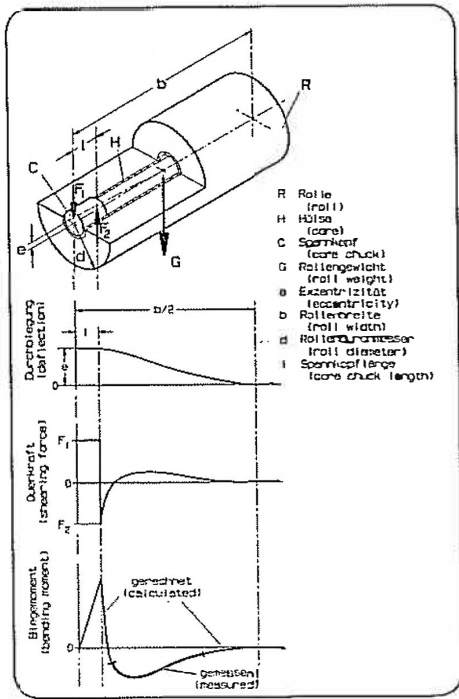


**Figure 1**  
 Machine models in accordance with the centre drum winder principle  
 a) JR 1000, Valmet; b) VARI-TOP, JAGENBERG;  
 c) Duo-roller II, Voith; d) Optislit, Goebel

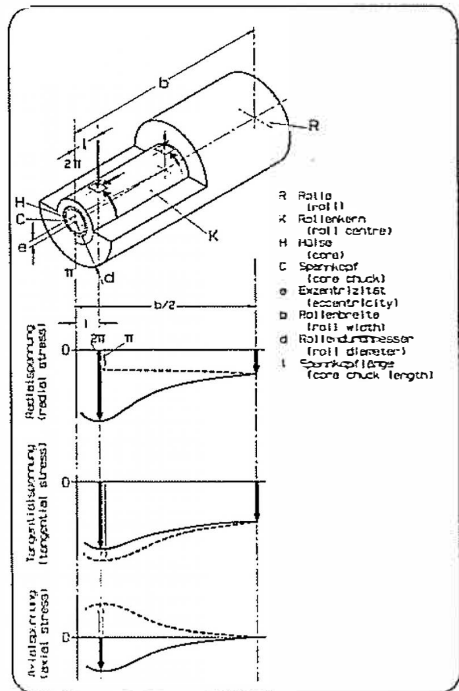




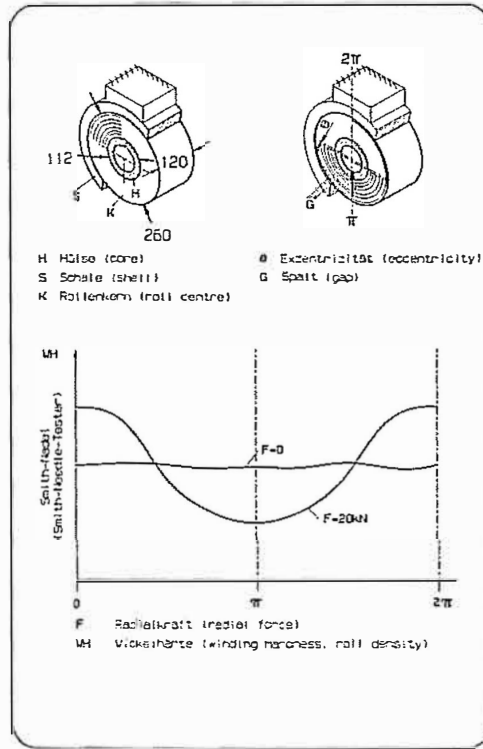
**Figure 2**  
 Comparison of specific core loading on the unwind of a printing machine and that of a single-drum winder.



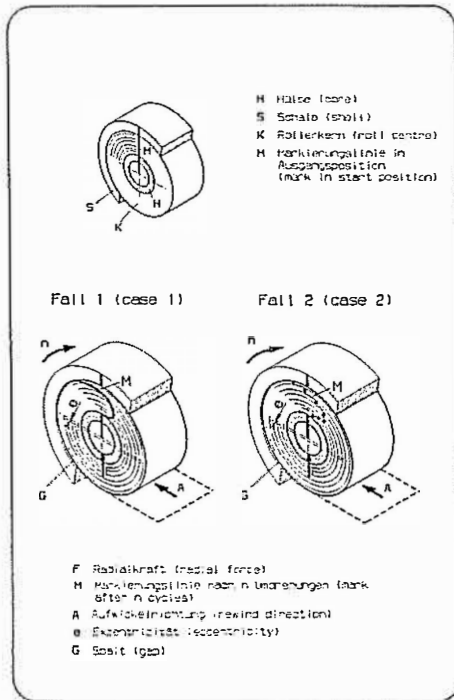
**Figure 3**  
Bending moment, shearing force, and deflection of the core of a jumbo reel during take-up by core-chucks



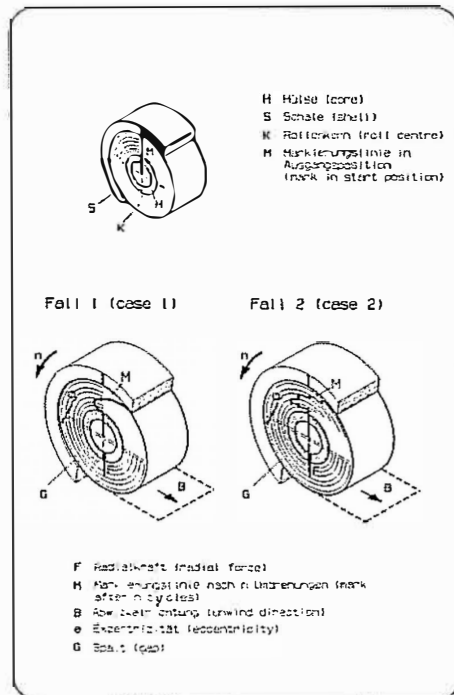
**Figure 4**  
Radial, tangential and axial stressing of the paper layers near the core of jumbo reels during take-up by core chucks



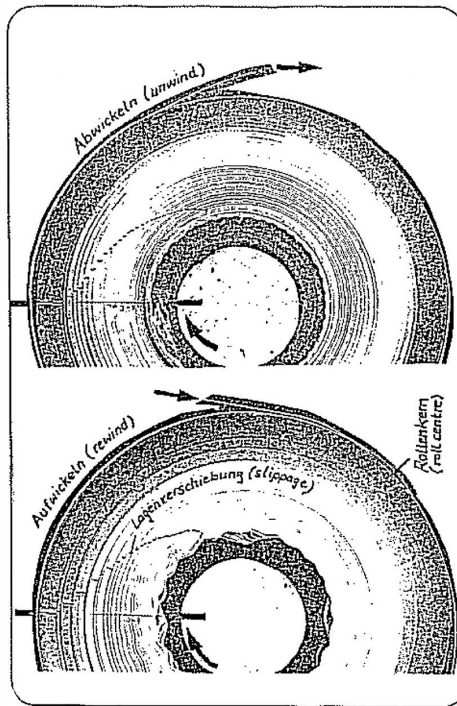
**Figure 5**  
 Change in the winding hardness development in a reel centre due to radial stress.



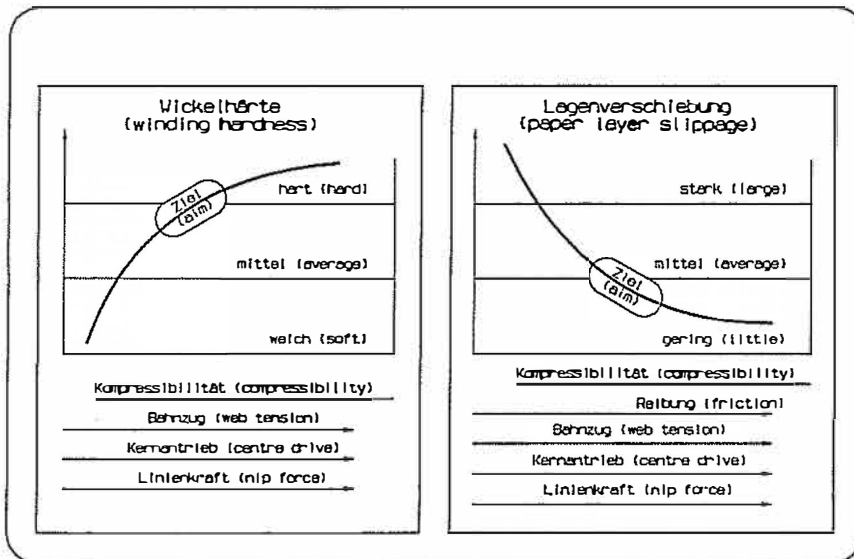
**Figure 6**  
Layer slippage in rewind  
direction;  
Case 1: without slab formation  
Case 2: with slab formation



**Figure 7**  
Layer slippage in unwind  
direction;  
Case 1: without slab formation  
Case 2: with slab formation



**Figure 8**  
Layer slippage in the reel centre (rewinding and unwinding)



**Figure 9**  
Winding hardness and layer slippage in relation to winding and paper parameters.