

UNIVERSITY OF MISSOURI COLLEGE OF AGRICULTURE
AGRICULTURAL EXPERIMENT STATION

E. A. TROWBRIDGE, *Director*

CIRCULAR 232

Columbia, Mo.

MAY, 1942

(Reprinted, October, 1946)

Plow Adjustment and Operation

MACK M. JONES AND LLOYD E. HIGHTOWER

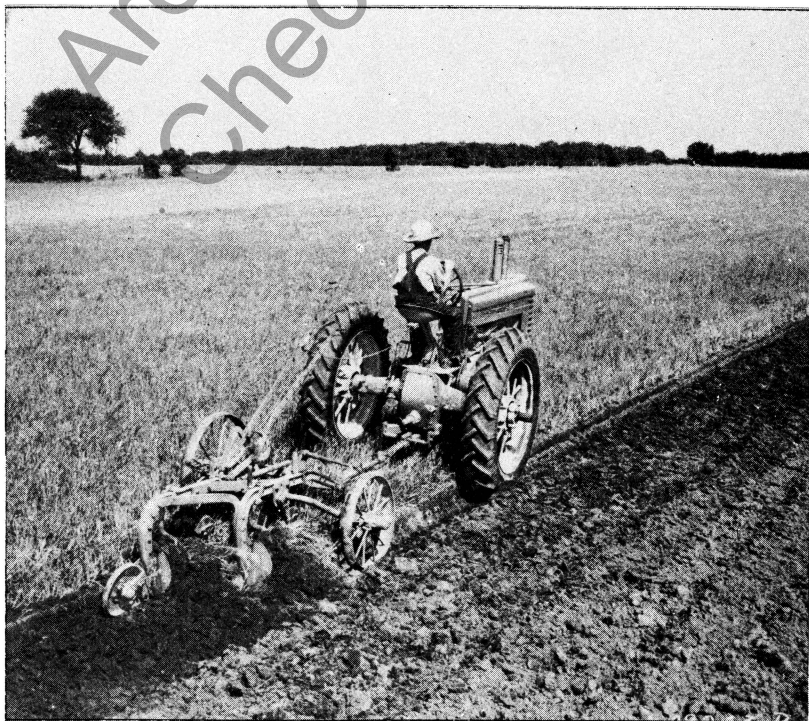

A properly adjusted plow will give real satisfaction to the operator through better work, lighter draft, and less wear on shares and other parts. Different plowing conditions are often encountered even on a single farm. Therefore plows need to be readjusted frequently. It is the purpose of this circular to outline the more important plow adjustments.

PLOWSHARES

The two most common causes of plowing difficulties are (1) dull, worn, or improperly sharpened shares, and (2) improper hitch.

Suction

A plow equipped with a new share has *down suction* and *side suction*; that is, the share is pointed downward, and also sideways toward the unplowed land. See Figs. 1 and 2. Down suction enables the plow to penetrate the soil, and the side suction holds the plow to an even, full-width furrow. It is important that the original down suction and side suction be restored when the plow shares are sharpened. Too much down suction will cause the plow to run on its nose, resulting in rapid wear of the points of the shares and in heavy draft.

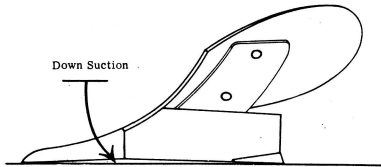

Fig. 1. Plows must have down suction to give penetration. The amount of clearance at the point indicated should be about $\frac{1}{4}$ to $\frac{1}{2}$ inch.

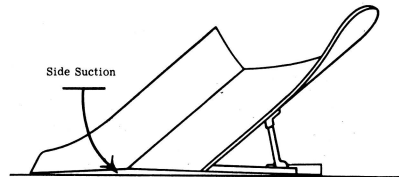

Fig. 2. Side suction enables the plow to cut an even, full-width furrow. The clearance at the point indicated should be about $\frac{1}{4}$ inch.

The proper amount of down suction will depend upon the type of plow and upon the soil conditions, but should usually be about $\frac{1}{4}$ to $\frac{1}{2}$ inch, measured at the point shown in Fig. 1. The side suction should usually be about $\frac{1}{4}$ inch, measured at the point shown in Fig. 2.

Sharpening Shares

Chilled iron shares cannot be heated and hammered. They may be sharpened by grinding on the top side. Chilled shares are moderate in cost and it is generally considered best to discard them when they become badly worn.

Steel shares are sharpened by heating and hammering. The share should be hammered on top, beginning at the point and working back toward the wing, heating and hammering only a small section at a time. The share should not be heated hotter than a cherry red. *It is important that the share be properly shaped to give the plow the desired suction.* On most plows the suction is obtained by bending the point down and sidewise the desired amount. On other plows the shape of the share and the bottom is such that the suction will be correct without bending the point.

Hardening Soft-Center Steel Shares

A soft-center steel share may be hardened by heating a strip about 2 inches wide along the edge to a uniform cherry red and then dipping

it in clean, cold water, cutting edge down. Some smiths heat the whole share to a cherry red before dipping.

Solid or crucible steel shares should be hardened very little if at all. Hardening makes them brittle and therefore subject to breakage.

Hard-surfacing Shares

Different kinds of extremely hard and long-wearing material can be applied to the points and cutting edges of steel shares by means of the welding torch. These materials will greatly increase the life of a share and when carefully applied, their use is generally satisfactory.

CENTER OF RESISTANCE

For a plow to do its best work with least draft, it should be pulled straight ahead from its center of resistance, or center of load. Therefore, in order to properly hitch a plow, the plowman should know how to locate this point.

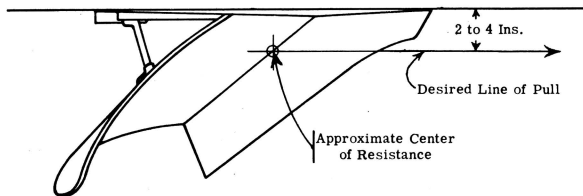

Fig. 3. A plow should be pulled straight ahead from its center of resistance. This point is about 2 to 4 inches to the right of the landside.

For all practical purposes the center of resistance of a one-bottom plow may be considered as a point 2 to 4 inches to the right of the landside, and on the line where the share joins the moldboard. See Fig. 3. For wide bottom plows the center of resistance is farther to the right than for narrow plows. The center of resistance is not a

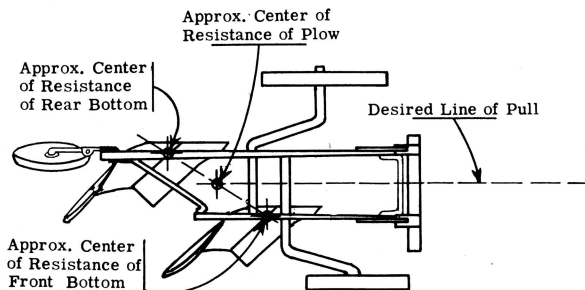

Fig. 4. The center of resistance of a two-bottom plow is about midway between the two beams. On a three-bottom plow it is about in line with the center beam.

definite fixed point, but it shifts considerably with varying soil conditions. For hard dry soil, it is farther forward and farther to the right than it is for moist soil.

The center of resistance of a gang plow is half way between the centers of resistance of the front and rear bottoms. See Fig. 4.

If it is impossible to hitch directly ahead of the center of resistance of a plow, as in the case of a wide-tread tractor or of a large team hitched abreast, then there will be side draft.

HITCH ADJUSTMENTS OF TRACTOR PLOWS

The most important adjustments on a plow are the hitch adjustments. There are two of them: (1) the horizontal or sidewise adjustment, and (2) the vertical or up-and-down adjustment.

Horizontal Adjustment

The first step in making the horizontal adjustment of the hitch is to determine the center of resistance of the plow. See page 3. On most two-bottom plows the center is about midway between the two beams; and on most three-bottom plows, it is about in line with the middle beam.

The second step is to adjust the tractor wheel tread, if possible, so that the middle hole of the tractor drawbar comes directly in front of the center of resistance of the plow. See Fig. 5. Setting the rear

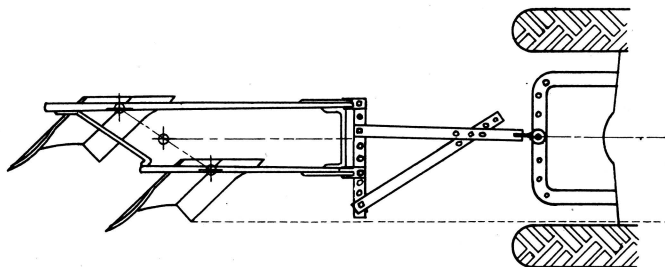

Fig. 5. An ideal hitch. The wheels of the tractor are set in so that the center line of the tractor is straight ahead of the center of resistance of the plow.

wheels in on wide-tread tractors, although quite important, is frequently neglected and results in side draft. In practice this means heavy draft, excessive fuel consumption, poor work, and rapid wear on the machines.

If it is not possible to make the center of pull come directly in front of the center of resistance of the plow, then a trial hitch should be made about midway between the middle hole on the tractor drawbar and the center line of resistance on the plow. See Fig. 6. In

making this trial hitch the right tractor drive wheel should be in the furrow about one inch from the furrow wall, and the plow should be in proper position behind the tractor so that the front bottom cuts the desired width of furrow.

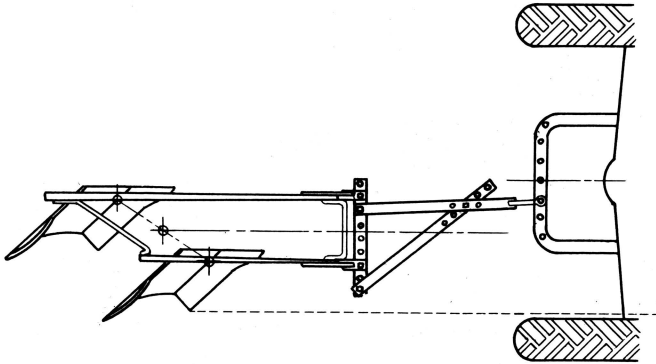

Fig. 6. When a wide tractor is used, it is best to hitch about midway between the center of the tractor and the center of resistance of the plow.

This trial hitch will divide the side draft between the tractor and the plow and will usually prove satisfactory. If it should not, however, then the hitch may be moved nearer the center of the tractor to improve the operation of the tractor, or nearer in line with the center of resistance of the plow to improve the operation of the plow.

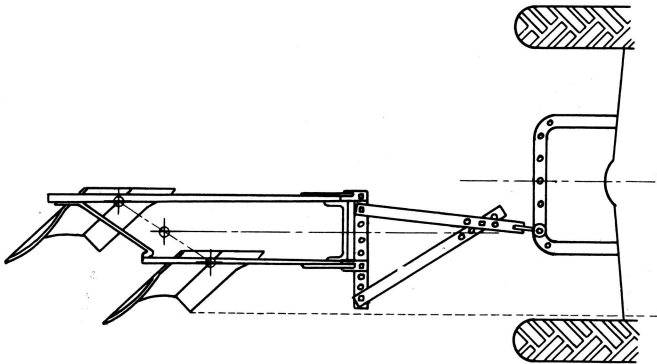

Fig. 7. This hitch places all the side draft on the tractor, making the tractor hard to steer.

If the hitch is too far off center on the tractor, the tractor tends to run sidewise and it will be difficult to steer. See Fig. 7. If the hitch is too far off center on the plow, the plow will tend to run sidewise, causing poor turning of the furrows and undue wear on the wheel bearings and landsides. See Fig. 8. Also, the draft will be considerably more than if pulled straight.

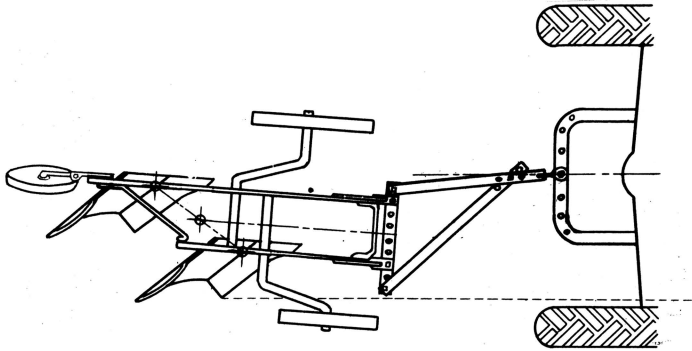

Fig. 8. This hitch places all the side draft on the plow. The plow runs at an angle, resulting in poor work, heavy draft, and rapid wear of the plow wheel bearings and landsides.

Adjusting Width of Front Furrow

The width of the front furrow should be changed by lengthening or shortening the diagonal member of the plow hitch and not by moving the clevis to a different hole in the tractor drawbar. Shortening the diagonal hitch member increases the width of front furrow; lengthening the member decreases the furrow width.

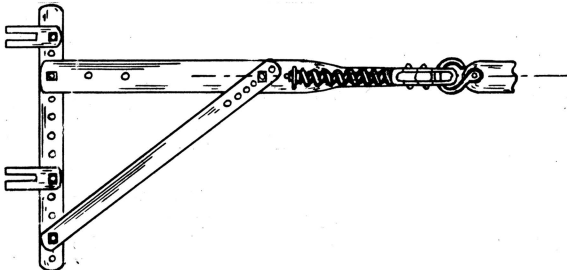

Fig. 9. The diagonal hitch bar should be adjusted to change the width of front furrow. When a spring safety release is used, the main hitch bar should extend about straight back from the tractor drawbar.

If a safety spring release is incorporated in the main draft bar of the plow hitch, then this bar should come straight back or nearly straight back from the tractor, as such safety releases can work best when the pull comes straight on them.

Setting in Only One Tractor Wheel

Sometimes in preparing wide-tread tractors for plowing, only one wheel is set in. While this may be better than not setting in either wheel, it is usually best to set both wheels in. If only one wheel is to be set in, then it is usually better to set the left one in rather than the right. This tends to equalize the weight on the two wheels and to keep the traction the same on both. The right wheel, since it runs

in the furrow, is lower and carries a little more weight than the left. If the right wheel should be set closer to the center of the tractor than the left one, then it would have to carry even more weight.

When the two wheels are not set the same distance from the center of the tractor, then the center of pull will be about midway between the two wheels (assuming equal traction on the two), rather than on the center line of the tractor.

A Long Hitch to Reduce Side Draft

Wherever side draft is troublesome, and cannot be remedied by placing the center line of pull nearer the center line of resistance, then a long hitch should be used. Placing the tractor somewhat farther ahead reduces the sidewise angle of pull, making the pull more nearly straight ahead, and consequently reduces side draft and improves the operation of both plow and tractor. See Fig. 10.

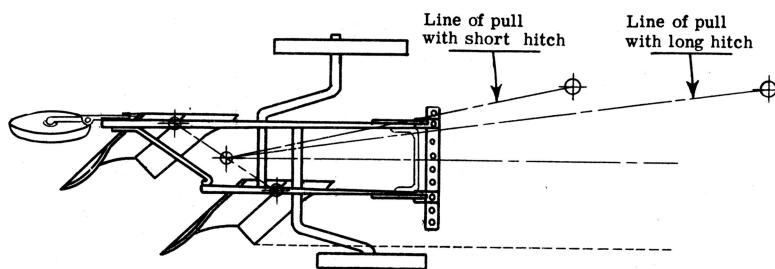

Fig. 10. A long hitch reduces the sidewise angle of pull when the tractor wheels are too wide apart.

Vertical Hitch Adjustment of Tractor Plows

The proper vertical adjustment of the hitch can best be made by keeping in mind the conditions that will result if the hitch is too high or too low.

If the hitch is too high there will be a downward pull on the front of the plow. See Fig. 11. This will cause excessive weight on the front wheels, with excessive wear on the wheel bearings. Also, there will be insufficient weight on the rear of the plow, and the rear wheel may come off the ground at times. The plow will run on its nose, and this will cause rapid wear on the share points. If the depth lever is unlatched the plow will immediately run deeper and the lever may be hard to control. The draft will be considerably heavier, and the plowing will be of a poorer quality. The furrows will be uneven in depth and unevenly turned because of "bobbing" of the rear of the plow. Under some conditions the plow may not scour well if the hitch is too high.

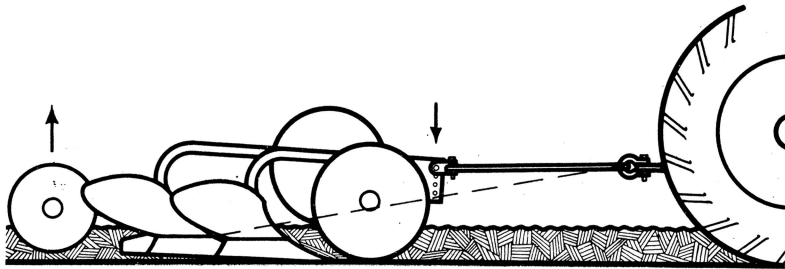

Fig. 11. Hitching too high places excessive weight on the front wheels and causes the rear of the plow to "bob" up, increasing draft and wear on share points.

If the hitch is too low there will be too much upward pull on the front of the plow, leaving insufficient weight on the front wheels. See Fig. 12. The plow will tend to run shallow, particularly in hard ground, and there may not be sufficient traction to operate the power lift wheel.

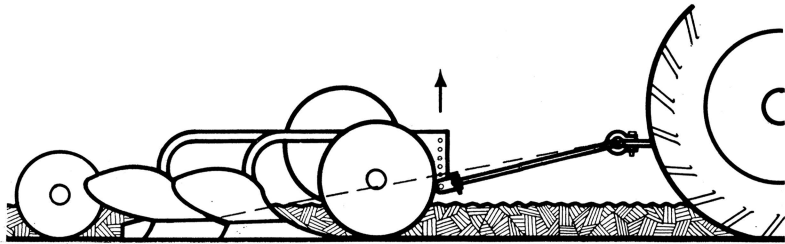

Fig. 12. Hitching too low lifts up the front of the plow. The plow may run shallow and the lift wheel may slip when the lift is tripped.

If the vertical adjustment of the hitch is right there will be a reasonably even distribution of weight on all wheels; the tracks will be about the same depth; and the depth of plowing will be reasonably uniform.

For lightest draft, the hitch should be set as low as possible and yet keep the plow running at the desired depth in all parts of the field. The vertical adjustment of the hitch should be changed with major changes in depth.

Tractor Drawbar Height Adjustment

Raising the tractor drawbar will have the same general effect on the plow as lowering the hitch at the front of the plow beams, and vice versa. *The height of the drawbar will also affect the operation of the tractor.*

If the tractor drawbar is too high, the weight on the front of the tractor may be reduced to such an extent that steering may be difficult. (Fig. 13.)

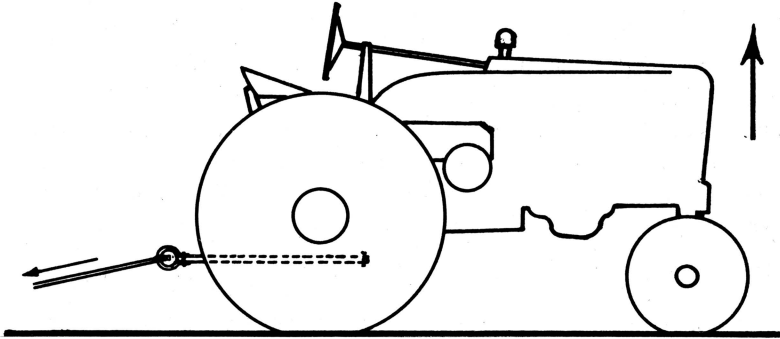

Fig. 13. When the tractor drawbar is too high, the front wheels do not carry enough weight, and the tractor is hard to steer.

If the tractor drawbar is too low, then the backward pull of the implement will tend to reduce the weight on the rear wheels of the tractor and place too much weight on the front wheels. See Fig. 14. If there should be appreciable reduction of weight on the rear wheels of the tractor, then wheel slippage may become troublesome. Slippage is not only a loss of power, but it is a cause of rapid tire wear in case of rubber tires.

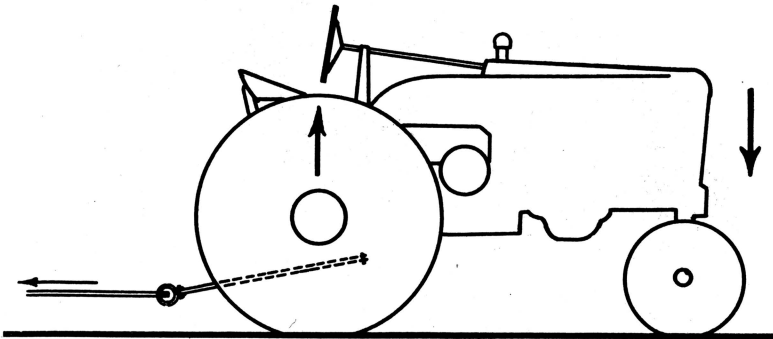

Fig. 14. Tractor drawbar set too low. The pull of the implement tends to reduce the weight on the rear wheels and may cause serious wheel slippage. Also there is likely to be too much downward pull on the front of the implement.

REAR WHEEL ADJUSTMENTS

The rear wheel on some types of tractor plows is not adjustable, but is mounted on a strong bracket in such a position that it carries most or all of the down weight at the rear of the plow and also a large part of the side or cross pressure tending to force the rear of the plow

against the furrow wall. On many plows the rear wheel is adjustable, both up and down and sidewise.

Landside Heel Clearance

The rear wheel, where adjustable, should be set low enough that it will carry the weight of the plow at the rear and not let the heel of the landside drag heavily on the bottom of the furrow. There should usually be at least some clearance under the heel of the landside. Where scouring may be difficult, as in heavy waxy soils, this heel clearance should be kept small. The heel clearance may be increased to $\frac{1}{2}$ inch or even slightly more in hard ground *if necessary* to secure penetration. If the heel clearance is too much, however, the

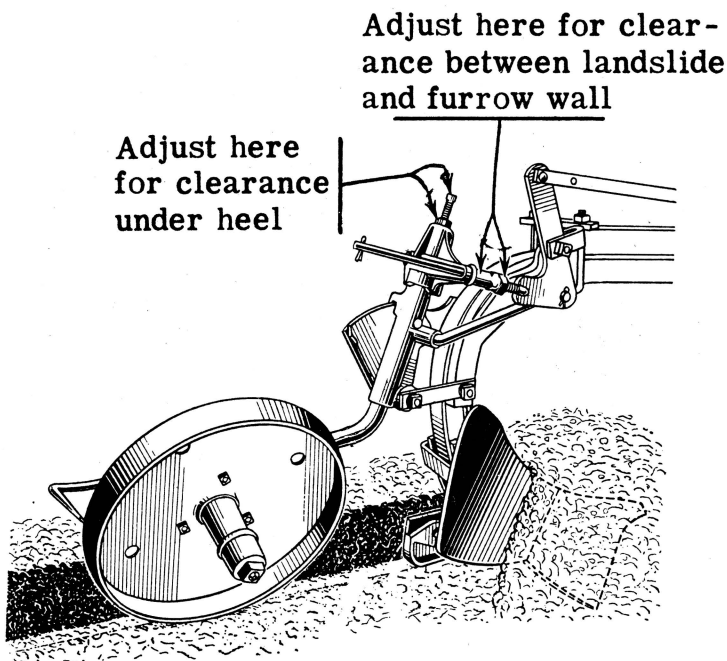

Fig. 15. The rear wheel should be set to carry the weight and the side thrust at the rear of the plow. The clearance between the landside and the furrow wall, and between the heel of the landside and the furrow bottom should usually be between $\frac{1}{4}$ and $\frac{1}{2}$ inch.

plow will tend to run on its nose, increasing the draft and the wear on the share points. The manufacturer's instruction book should be consulted for the recommended amount of heel clearance. In the absence of specific instructions, it will usually be safe to set this clearance at about $\frac{1}{4}$ to $\frac{1}{2}$ inch. See Fig. 15.

Clearance Between Landside and Furrow Wall

When in proper adjustment the rear wheel runs against the furrow wall, relieving the landside of most of the side pressure, and leads straight ahead or slightly away from the furrow wall. The clearance between the landside and the furrow wall should usually be from $\frac{1}{4}$ to $\frac{1}{2}$ inch. See Fig. 15.

Sprung Rear Wheel Brackets

Sometimes the rear wheel bracket or shank may be sprung by backing or by striking some obstruction. Also, brackets may work loose. In such cases, the plow cannot be expected to do good work without undue draft or wear. The remedy, obviously, is to straighten or tighten the parts and place the rear wheel in proper alignment.

COULTERS

A rolling coulters is used to form a clean, smooth furrow wall, and to cut through trash. Rolling coulters also usually reduce the draft of a plow.

A rolling coulters may be adjustable in three ways: (1) Up and down, for depth; (2) sidewise; and (3) forward or backward on the beam. This third adjustment is not provided on all plows.

Coulters Depth Adjustment

The coulters should be set at a depth at which it will best cut the trash and at the same time form a clean, smooth furrow wall. The depth setting will usually be right when the coulters cuts about half

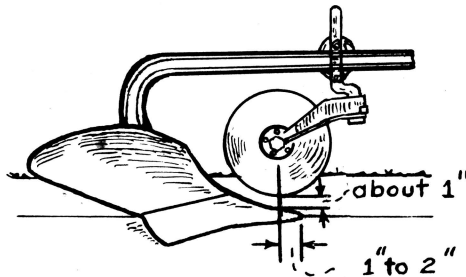

Fig. 16. For average plowing the coulters should be set to cut half the depth of plowing, or to within about 1 inch of the share; and the hub should be 1 to 2 inches back of the point of the share.

the depth of plowing, or to within about 1 inch of the share. See Fig. 16. If set too deep the coulters may tend to push the trash ahead instead of cutting through it; and if set too shallow, it may run over

the trash without cutting it. In general, the setting should be shallower in hard ground than in mellow ground, and deeper in sod than in stubble ground.

Fore and Aft Adjustment of the Coulter

When this adjustment is provided, the coulter usually should be set with the hub over the point of the share or one or two inches back of the point. See Fig. 16. In loose mellow ground, the coulter may be set a little ahead of the point. Also, in trashy ground, or when using a combination coulter and jointer, it may be better to set the coulter somewhat ahead unless the ground is hard. In case of hard ground the coulter should be set well back of the point. Otherwise the coulter may tend to hold the front of the plow up and make it run shallow.

Sidewise Adjustment

The coulter should be set far enough to the left of the landside to cut a clean furrow wall—usually about $\frac{1}{2}$ to $\frac{3}{4}$ inch. See Fig. 17.

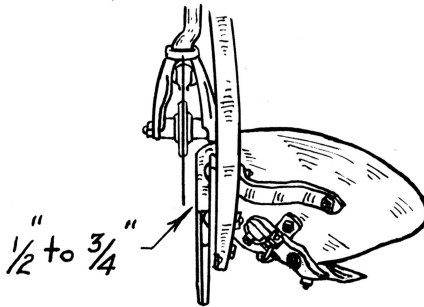

Fig. 17. The coulter should be set far enough to the left of the landside to cut a clean furrow wall—usually about $\frac{1}{2}$ to $\frac{3}{4}$ inch.

A convenient method of making a trial adjustment is to hold a “one-inch” board (which is really about $\frac{3}{4}$ inch thick) against the landside, and then set the coulter with the disk flat against the outside of the board. A crumbled, rough, or broken furrow wall is usually the result of improper sidewise adjustment of the coulter, although setting the coulter too shallow will also contribute to this trouble.

If there is difficulty in scouring, setting the coulter farther to the left will usually help. This makes the plow cut a slightly wider furrow, putting more pressure on the moldboard and polishing it faster.

Adjustment of Coultter Bearings

Many coultters have bearings which can be adjusted by tightening nuts on the spindle bolts. These bearings should be kept tight enough to prevent play or wobbling, yet they should not be tight enough to bind.

Size of Coultter

Large coultters are much better than small ones for cutting trash. See Fig. 18. Small ones tend to push the trash ahead, while the larger ones cut through. Large coultters also last much longer.

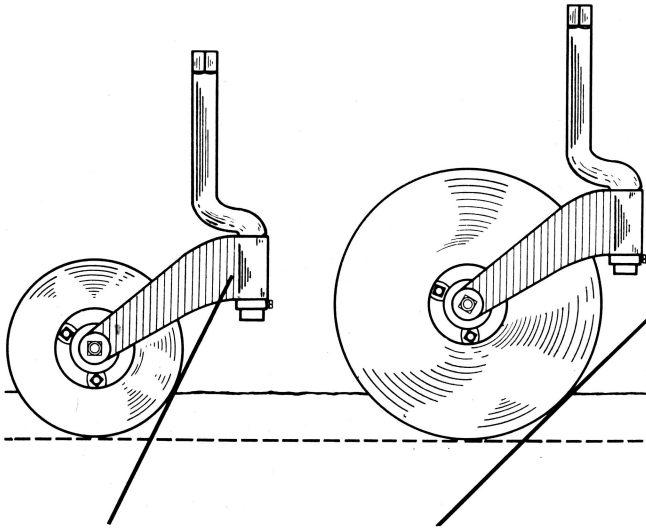

Fig. 18. Large coultters cut trash much better than small ones.

Notched or scalloped coultters are preferred by some for extremely trashy conditions, although large plain coultters are usually satisfactory if they are kept sharp and properly adjusted. They may be sharpened by filing or grinding.

Adjustment of Combination Coulter and Jointer

Jointers, when properly adjusted, are of considerable help in covering trash. They are especially valuable in grassy or soddy ground. A jointer should usually be set to cut about 2 inches deep. The point should be set close to but *should not touch* the coulter disk. The space between the jointer and the coulter should widen toward the rear, and should be about $\frac{1}{2}$ inch at the extreme back. See Fig. 19. This V-shaped clearance prevents trash from lodging between the jointer and the coulter.

Fig. 19. The point of the jointer should almost touch the coulter disk, and the space between the jointer and the disk should widen toward the rear. The jointer should usually cut about 2 inches deep.

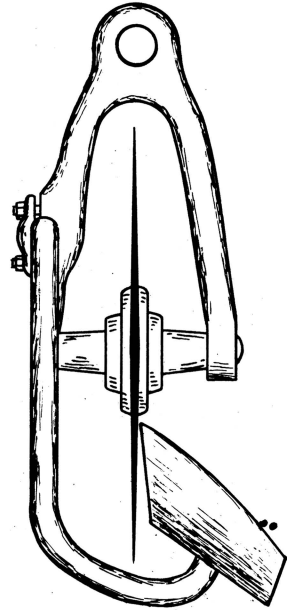

Adjustment of Lifting Springs

There should be some tension on the lifting springs with the plow in the raised position and with the levers set for shallow plowing. If the springs are too loose, the levers will be hard to shift; and the power lift wheel may slip when the trip is pulled to lift the plow. If the springs are too tight, the plow may not enter the ground promptly when tripped. Also, on some plows, the power lift wheel may slip when the plows are entering the ground.

Integrally Mounted Tractor Plows

Plows which are mounted on the tractor are somewhat cheaper than other tractor plows, and can be easily maneuvered close to fences and into corners. The absence of axles and wheels, however, makes these plows light in weight. This means that the bad effects of dull or worn shares will be more pronounced than with pull-behind type plows. In some cases dull shares will cause the plow to come out of the ground.

There is usually more side draft on integrally mounted plows than on the pull-behind type, because they are hitched closer, and because they are usually of narrow cut, thus offsetting the center of resistance

farther from the center line of the tractor. The side draft may not be serious, however, because the plows are small in size and the draft therefore not excessive.

Backing Tractor Plows

Backing some tractor plows in or out of the shed can be done more easily by setting the depth lever in the shallowest notch, and tripping the plow into plowing position. This will lock the rear wheel rigid and yet the plows will clear the ground.

WALKING PLOWS

Wing Bearing

Shares on walking plows should have down suction and side suction about the same as other plows. In addition, they should have wing bearing. That is, the wing or tip of the share nearest the plowed ground should be so shaped that a flat surface—not just an edge—bears against the bottom of the furrow. If the plow is turned upside down and a straight edge placed from the heel of the landside to the wing of the share, the straight edge would touch the bottom of the share for a distance of about $\frac{3}{4}$ inch in the case of 12-inch plow, about $1\frac{1}{4}$ inches for a 14-inch plow, and about $1\frac{1}{2}$ inches for a 16-inch plow. See Fig. 20.

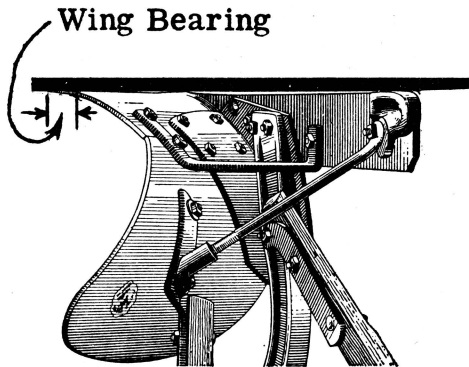

Fig. 20. The share of a walking plow needs wing bearing of from $\frac{3}{4}$ to $1\frac{1}{2}$ inches to help support the outer edge of the plow.

The wing bearing helps support the outside edge of the plow and keep it balanced and running level. Too little wing bearing may cause the plow to lean toward the plowed ground, and too much may cause it to lean toward the unplowed ground. No wing bearing is

required for riding plows or for tractor plows, as the wheels carry the down load due to the weight of the plow and the soil being turned over the moldboard.

The length of evener used on a walking plow, as well as the amount of wing bearing, will affect the tendency of the plow to lean one way or the other instead of running level. See below.

Vertical Adjustment of Hitch

The depth of plowing with a walking plow is regulated by the vertical adjustment of the hitch on the front of the plow. Hitching higher makes the plow run deeper, and hitching lower makes the plow run shallower. See Fig. 21.

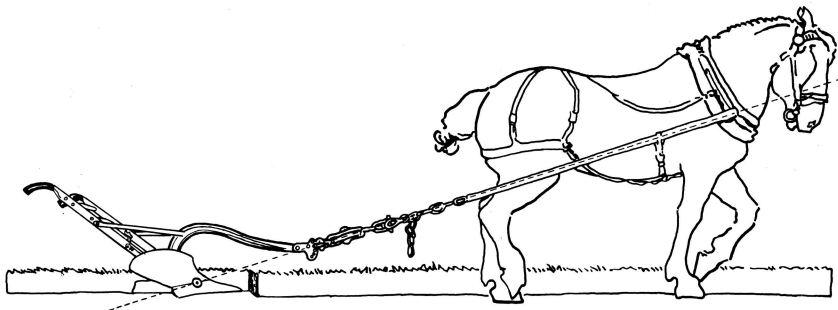

Fig. 21. The depth of plowing is regulated by the height of hitch on a walking plow. The point of hitch is always in line with the center of resistance of the plow and the front end of the traces.

The length of traces also affects the depth of plowing, longer traces making the plow run somewhat deeper. The traces should usually be just long enough to prevent the single trees from bumping the horses' heels while turning.

Horizontal Adjustment of Hitch

The purpose of the horizontal or sidewise adjustment of the hitch, is mainly to regulate the plow balance and offset any tendency of the plow to lean to one side or the other. The width of furrow can be changed by changing the hitch, although the width of furrow is more properly regulated by the length of the evener.

If the evener clevis is hitched to the right of the center of the beam, the plow will tend to lean to the left or toward the unplowed ground. On the other hand, if the hitch is much to left of the center, the plow will tend to lean to the right or toward the plowed ground. It is true that by proper adjustment of the wing bearing, as explained on page 15, this tendency to lean one way or the other may be partly or entirely corrected.

Length of Evener

The length of evener should be such that with one horse walking naturally in the furrow, the center of the evener will be in line with the end of the beam when the plow is cutting the desired width of furrow. See Fig. 22. The evener should be about 38 inches long for a 14-inch plow and about 32 inches long for a 12-inch plow.

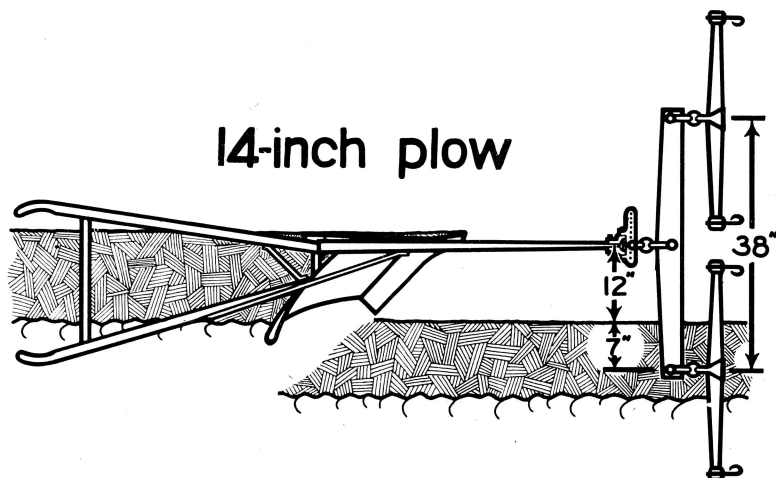

Fig. 22. The length of evener should be about 38 inches for a 14-inch plow, and about 32 inches for a 12-inch plow.

The beam of a three-horse plow is angled somewhat more toward the unplowed ground than the beam of a two-horse plow. This is to make the beam come more nearly in line with the center of pull, and thus avoid the necessity of hitching the clevis too far to the left of the center of the beam.

HORSE-DRAWN RIDING PLOWS

Hitch Adjustments

Exactly the same principles are used in making the hitch adjustments on horse-drawn riding plows as on tractor plows. See pages 4 to 8. See also Fig. 23.

It is probably more important to have the hitch correctly made on horse-drawn plows than on tractor plows. With horses there is usually no excess power available and any increased draft due to improper adjustments seriously decreases the amount of work done.

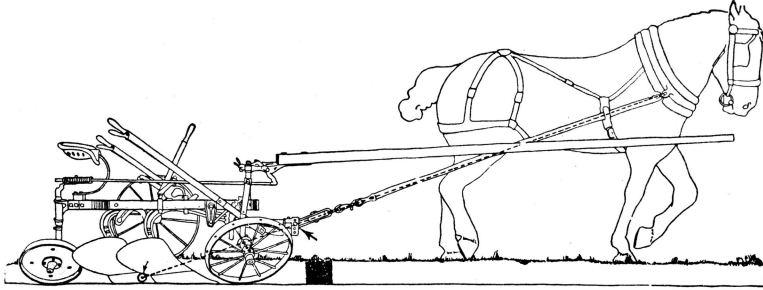

Fig. 23. When the height of hitch on the front of the plow is correct, the clevis pin will be in line with the center of resistance of the plow and the point of pull, and each wheel will carry its proportionate share of the weight.

Tandem Hitches

Tandem hitches are usually better than abreast hitches when four or more horses are to be worked to a plow. With four horses abreast, the

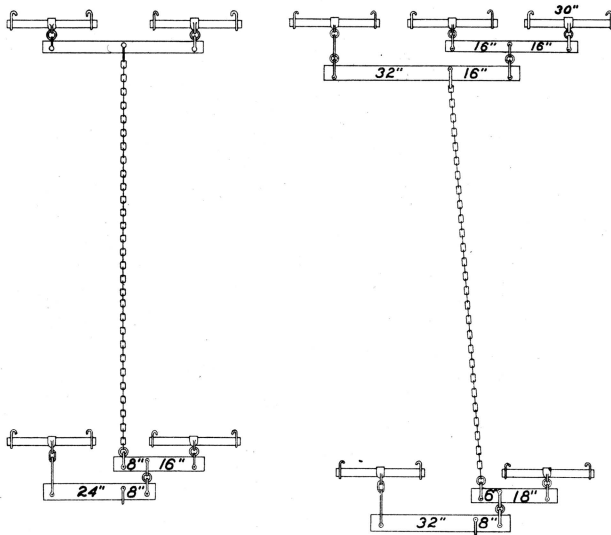

Fig. 24. Tandem hitches for 4- and 5-horse teams. Such hitches reduce or eliminate side draft, and make for lighter draft, better plowing and easier work for the horses.

center of pull is so far to the left of the center of resistance of the plow that there bound to be considerable side draft, resulting in heavy draft, poor operation of the plow, and hard work for the horses. A tandem hitch makes it possible for the center of pull to be placed in line with, or nearly in line with the center of resistance. Side draft is thus avoided or kept at a minimum.

Fig. 24 shows eveners for tandem hitches for four-horse and for five-horse teams.*

Rear Furrow Wheel Adjustments

The rear furrow wheel of horse-drawn plows, where adjustable, should be set to provide clearance between the furrow wall and the landside, and between the furrow bottom and the heel of the landside in the same general way as on tractor plows. See page 10. See also Figs. 25 and 26.

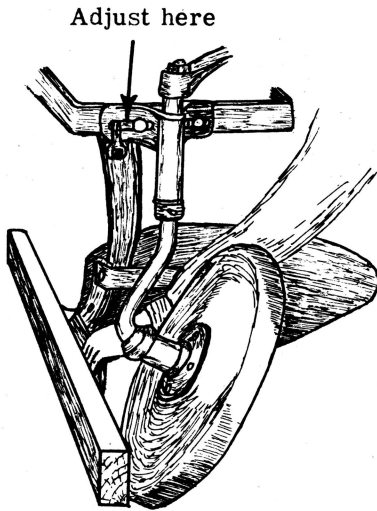

Fig. 25. A typical adjustment to give landside clearance. There should be room for the fingers between the landside and the furrow wall.

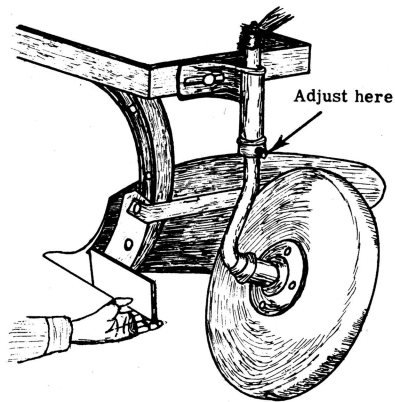

Fig. 26. There should be clearance under the heel of the landside for the fingers. Adjustment is made by raising or lowering the collar on the rear wheel shank.

Lead of Furrow Wheels

The lead or steering of the front furrow wheel on most horsedrawn plows is adjustable; and, in many cases, the lead of the rear furrow wheel is also adjustable.

When the hitch is directly in front of the center of resistance of the plow, then the front wheel should be set to lead straight ahead, and the rear wheel to lead straight ahead or very slightly away from the furrow wall.

When the hitch is to the left of the center of resistance, the rear of the plow tends to swing toward the furrow wall and the front of the plow tends to swing to the right or away from the furrow wall.

*For additional information on tandem hitches see Missouri Agricultural Extension Circular 403 on *Care and Hitches for Work Horses*.

Under such conditions the rear wheel should be set to lead slightly away from the furrow wall and the front wheel slightly toward the wall in order to counteract the tendency of the plow to run sidewise. See Fig. 27. The wheels must not be set at too great an angle, however, or they will drag sidewise, increasing the draft and wear on the wheels and wheel bearings, and still not make the plow run straight.

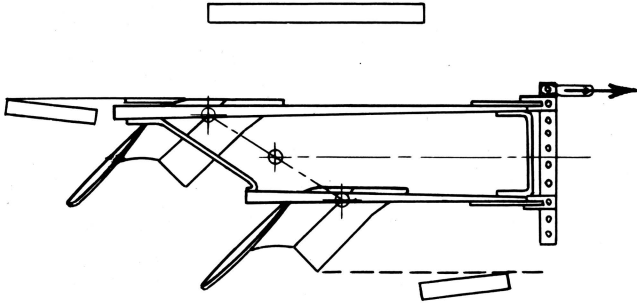

Fig. 27. When the hitch must be to the left of the center of resistance, the rear furrow wheel should be set to lead away from the furrow wall slightly, and the front wheel toward the furrow wall slightly.

GENERAL SUGGESTIONS

Failure to Scour

Sometimes a plow must be used considerably before it acquires sufficient polish to insure good scouring. In cases of difficult scouring, setting the coulter as far to the left as practical, setting the plow shallow, and pulling it at a high speed, will usually help.

Protection of Polished Parts

When plows are not in use the moldboards and other polished parts should be protected against rust by a coat of heavy grease. Rust pits, even though small, seriously interfere with scouring and greatly increase the draft.

Sprung Beams

If one beam of a multiple-bottom plow is sprung or if a bottom is out of line with the others, the plow will not turn uniform furrows. A simple check for sprung beams or misaligned bottoms may be made by letting the plow down on a smooth level place or floor. By adjusting the levers it should be possible to make the points of all shares and the wings of all shares touch the floor. Also, the distance between corresponding points on any two bottoms should be the same. See Fig. 28. Turning a plow upside down or raising it high off the ground and sighting along the points and wings of the shares will help determine if a beam is sprung or a bottom is out of line. Another check is to

measure from the point of the share straight up to the beam on the different bottoms. These measurements should be the same for all bottoms. Sometime the large bolts holding a bottom to a beam will work loose allowing the bottom to get out of line.

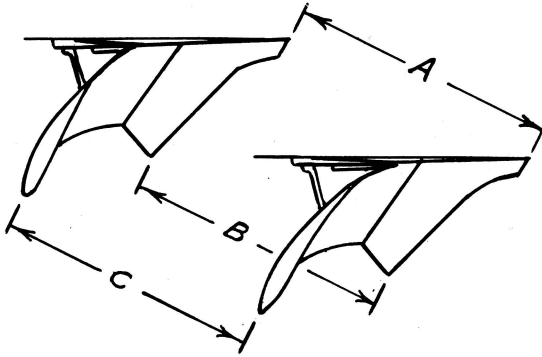

Fig. 28. A good way to check for sprung beams. The measurements A, B, and C should all be the same.

Straightening a sprung beam is a job requiring expert work and one which can rarely be done satisfactorily. Heating a beam would destroy the temper of the metal and then it would not likely retain its proper shape even if it were straightened or properly aligned.

Lubrication of Wheel and Coulter Bearings

It is important for long life and easy running that wheel and coulter bearings be kept well lubricated. Probably the most satisfactory method is to use a pressure grease gun. Most late model plows are equipped with fittings for pressure guns. These fittings can usually be installed easily on old plows, and this would certainly be recommended for plows that are to be used much.

In addition to greasing the wheel and coulter bearings regularly each day with a pressure gun, it is a good plan to take the bearings completely apart once or twice a season, and wash with kerosene, pack with fresh clean grease and reassemble.

Trash-covering Wires

Covering of trash and weeds can frequently be improved by fastening a 10- or 12-foot length of heavy wire to the lower end of each coulter shank, and allowing the wires to drag back under the furrows as they are being turned. An additional wire tied to the front furrow

wheel shank, or to the plow frame near the front wheel, will also help. See Fig. 29.

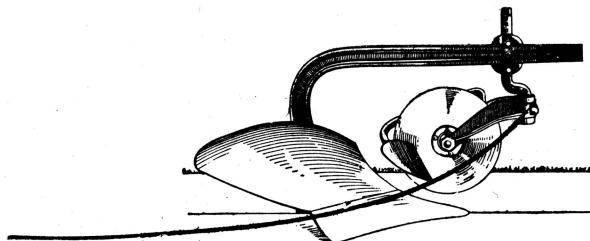

Fig. 29. A 10- or 12-foot length of heavy wire drug from the lower end of each coulter shank, is a great help in covering trash.

Removing Paint or Varnish

Paint or varnish should be removed from new moldboards before attempting to plow with them. This may be done by the use of paint remover or strong lye water. Such materials should be applied immediately before going to the field, and should not be allowed to remain on the moldboards too long because of the danger of damaging the polish.

HINTS ON PLOW ADJUSTMENT AND OPERATION

Don't run one bottom deeper than the other.

Set the coulters to make clean furrows.

Don't hitch so high that the rear wheel jumps, nor so low that the front one runs light.

The share must have suck if the plow is to stay down.

Keep all nuts tight.

Don't forget to lubricate the wheels and coulters.

Be sure to grease the moldboards and other polished parts if the plow is to be out of use more than a few hours.

Keep the bottoms bolted tight to the beams.

Properly adjusted lifting springs help the operator shift the levers.

They also help the plow raise itself.

Accidents can be prevented.

The best safety device is a careful operator.

Never clean, oil, or adjust a machine while it is in motion.

Oil prevents wear, saves repairs, and lightens draft.

An implement incorrectly set up or improperly operated cannot do best work.

Save the manufacturer's instruction book. Study it. It contains many helpful suggestions and a list of repair parts.

When ordering repairs, give the numbers of the parts if possible.

Correct hitching results in light draft, low fuel consumption, and better plowing.

Digitization Information Page

Local identifier C232-1942

Source information

Format Book
Content type Text /Text with images
Source ID Gift copy not added to collection
Notes

Capture information

Date captured October 2019
Scanner manufacturer Fujitsu
Scanner model fi-7460
Scanning system software ScandAll Pro v. 2.1.5 Premium
Optical resolution 600 dpi
Color settings 8 bit grayscale
File types tiff

Derivatives - Access copy

Compression Tiff: LZW compression
Editing software Adobe Photoshop CC
Resolution 600 dpi
Color grayscale
File types pdf created from tiffs
Notes Images cropped, straightened, and brightened
Canvas size: 6 x 9