

© 2018 IEEE. Personal use of this material is permitted. Permission from IEEE must be obtained for all other uses, in any current or future media, including reprinting/republishing this material for advertising or promotional purposes, creating new collective works, for resale or redistribution to servers or lists, or reuse of any copyrighted component of this work in other works.

Digital Object Identifier (DOI): 10.1109/TIE.2017.2714143

IEEE Transaction on Industrial Electronics (Volume: 64, Issue: 9, Sept. 2017)

Damping Methods for Resonances Caused by LCL-Filter-Based Current-Controlled Grid-Tied Power Inverters: An Overview

Weimin Wu

Yuan Liu

Yuanguin He

Henry Shu-Hung Chung

Marco Liserre

Frede Blaabjerg

Suggested Citation

W. Wu, Y. Liu, Y. He, H. S. Chung, M. Liserre and F. Blaabjerg, "Damping Methods for Resonances Caused by LCL-Filter-Based Current-Controlled Grid-Tied Power Inverters: An Overview," in *IEEE Transactions on Industrial Electronics*, vol. 64, no. 9, pp. 7402-7413, Sept. 2017.

Damping Methods for Resonances Caused by LCL-filter-based Current-controlled Grid-tied Power Inverters: an Overview

Weimin Wu, Yuan Liu, Yuanbin He, Student Member, IEEE, Henry Shu-Hung Chung, *Fellow, IEEE*, Marco Liserre, *Fellow, IEEE*, and Frede Blaabjerg, *Fellow, IEEE*

Abstract - Grid-tied voltage source inverters using *LCL*-filter have been widely adopted in distributed power generation systems (DPGSs). As high-order *LCL*-filters contain multiple resonant frequencies, switching harmonics generated by the inverter and current harmonics generated by the active / passive loads would cause the system resonance, and thus the output current distortion and oscillation. Such phenomenon is particularly critical when the power grid is weak with the unknown grid impedance. In order to stabilize the operation of the DPGS and improve the waveform of the injected currents, many innovative damping methods have been proposed. A comprehensive overview on those contributions and their classification on the inverter- and grid-side damping measures are presented. Based on the concept of the impedance-based stability analysis, all damping methods can ensure the system stability by modifying the effective output impedance of the inverter or the effective grid impedance. Classical damping methods for industrial applications will be analyzed and compared. Finally, the future trends of the impedance-based stability analysis, as well as some promising damping methods, will be discussed.

Index terms—*LCL*-filter, current-controlled, grid-tied inverter, distributed power generation system, stability, damping, generalized Nyquist stability criterion, impedance-based stability analysis.

I. INTRODUCTION

THE rapid evolution of society and technology brings a vast increase in energy demand. Fossil fuels will soon be running out. The environmental problems caused by the fossil fuel consumption make the society pay more attentions

Manuscript received Sep. 19, 2016; revised Dec.20, 2016 and Mar.20, 2017; accepted May 10, 2017. This work was supported in part by the Electrical Engineering Department of Shanghai Maritime University and the Electrical Engineering Department of the City University of Hong Kong under Grant of NSFC/RGC Joint Research Scheme (Project No.: 51561165013) and (Project No.: N_CityU128/15).

Weimin Wu and Yuan Liu are with the Electrical Engineering Department, Shanghai Maritime University, Shanghai, China (phone: 8621-38282600; fax: 8621-38284339; e-mail: wmwu@shmtu.edu.cn).

Yuanbin He and Henry Shu-Hung Chung are with the Electrical Engineering Department, CityU, Hongkong, China (phone: 8523442-7807; fax: 8523442-0562; e-mail: eeshc@cityu.edu.hk).

Marco Liserre is with the Chair of Power Electronics, Christian-Albrechts-University of Kiel, 24118 Kiel, Germany (phone: 49 431-8806100; Fax: 49431-8806103; Email: ml@tf.uni-kiel.de).

Frede Blaabjerg is with the Energy Engineering of Aalborg University, Aalborg, Denmark (e-mail: fbj@et.aau.dk).

to shifting to using renewable energy resources, such as sun and wind. Distributed Power Generation Systems (DPGS) develop fast worldwide. Grid-tied inverters are key components in connecting renewable energy sources with the existing power grids [1]-[4]. In order to attenuate the switching frequency harmonics caused by grid-tied inverter and meet statutory requirements [5], [6], a passive power filter should be adopted. Compared with the classical *L*-filter, the *LCL*-filter has received more and more attention due to its small size as well as reduced costs [7]-[10].

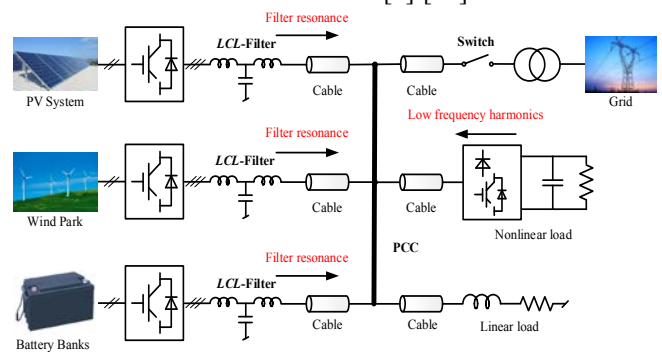

Fig. 1. Power-converter-based DPGS.

Fig. 1 shows a DPGS with different sources and loads. Grid-tied inverters inject power generated by the renewable energy resources into power grid. Both linear and nonlinear loads are connected to the PCC. In such an architecture, a grid-tied inverter with *LCL*-filter will face the following challenges,

- 1) The resonance caused by *LCL*-filter may destabilize the inverter system [7], [8].
- 2) The nonlinear loads in DPGS will cause low-frequency harmonics and distort the PCC voltage, which inevitably disturbs the operation of the grid-tied inverter [2],[11].
- 3) In practice, the equivalent grid impedance for the local grid-tied inverter may vary widely [2], [12]. When the grid impedance increases, the control bandwidth of the local grid-tied power inverter may become narrower, worsening the dynamic performance, or even resulting in system instability [2].
- 4) The interaction among grid-tied inverters may destabilize the entire DPGS [3],[13].

In order to achieve a stable DPGS, the controller design for grid-tied inverters should be fully addressed. There are two basic control modes for grid-tied inverters. They are including current- and voltage-control modes. Although research on the grid-tied inverter with voltage control has

been recently emphasized [14]-[17], this paper will focus on current-controlled inverters.

In order to successfully integrate current-controlled grid-tied inverters into DPGS, an inverter designer or an integrator has to pay special attentions on the following issues,

- 1) In DPGS, interactions among paralleled inverters are induced through the coupled grid impedance [3]. Thus, the power grid is expected to be stiff enough to ensure a very small grid impedance.
- 2) If the power grid is weak, the variation of the equivalent grid impedance should be fully addressed in the controller design for grid-tied inverters [18].
- 3) The impedance-based stability analysis and the generalized Nyquist stability criterion, which originated from the assessment of DC system [19] [20], are still a useful tool to assess the stability of AC DPGS.

Generally, different damping techniques need to be adopted to suppress possible resonances and avoid system instability in designing the controller.

In this paper, methodologies are first introduced to assess the stability of AC DPGS in Section II. Then, based on the concept of impedance-based stability analysis, this paper gives an overview on the damping methods to attenuate possible resonances. All those methods are classified into: inverter- and grid-side damping types, which are introduced in Sections III and IV respectively. Further, Section V summarizes the key points in the parameter design of classical damping methods, evaluates the performance, and discusses the damping robustness. Finally, Section VI concludes this paper and points out the future research trends in this topic.

II. METHODOLOGIES TO ASSESS THE STABILITY OF AC DPGS

The stability of AC DPGS earns more and more attentions. Different methods have been proposed to analyze the system stability.

A. Eigenvalue -Based Analysis

In the AC power system, the eigenvalue-based analysis are widely adopted to assess the small-signal stability of the systems[21], [22]. The eigenvalue-based stability analysis is usually based on studying the eigenvalues of system state space model matrix, which needs all information of elements in the system, including the physical characteristics and the control parameters [23]. However, the control parameters of grid-tied inverters are generally unavailable, especially when analyzing the stability of a large scale power-converters-based AC DPGS.

B. Impedance-Based Stability Analysis

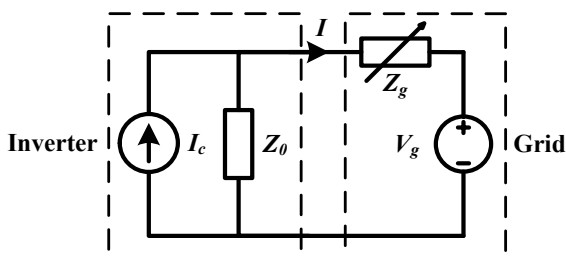

Fig. 2. Equivalent circuit of the current-control-based grid-tied inverter.

In order to handle the stability of the AC DPGS, recently, the impedance-based stability analysis, which originated from the generalized Nyquist stability criterion proposed by R. D. Middlebrook to access the stability of the DC system [19], has been widely investigated [23]-[33].

Ref. [24] gave a more detailed description on the impedance-based stability method for the grid-tied current-controlled inverters, which are widely used in DPGSs. As shown in Fig. 2, a current-controlled inverter is modeled by a current source I_c in parallel with the output admittance Z_o under the condition of zero grid impedance, and the grid is represented by a voltage source V_g in series with the equivalent grid impedance Z_g . The grid impedance mainly consists of the line impedance and the transformer output impedance, but the equivalent grid impedance for a local current-controlled inverter still depends much on the number of grid-tied inverters connected to the PCC [12].

Based on the Thevenin's and Norton's equivalent circuits, if the grid voltage can be assumed to be stable without the inverter and the inverter can be assumed to be stable when the grid impedance is zero, then the injected-current of grid-tied inverter can be described as follows,

$$I(s) = \left[I_c(s) - \frac{V_g(s)}{Z_o(s)} \right] \cdot \frac{1}{1 + Z_g(s)/Z_o(s)} \quad (1)$$

If the minor-loop-gain of $Z_g(s)/Z_o(s)$ can meet the generalized Nyquist stability criterion [19], then the current-controlled grid-tied inverter system can keep stable.

C. Application Issue Related to the Impedance-Based Stability Analysis

The principle of impedance-based stability analysis has been widely accepted by the academia and industrial community. However, views still vary on how to apply the impedance-based stability analysis to guide the design of grid-tied power converters in the AC DPGS.

Since the impedance-based stability analysis is a kind of the small-signal analysis method and the AC DPGS has no time-invariant operating point, some researchers carried out the impedance-based stability analysis in the rotating (dq) reference frame [25]-[32]. Due to the dq transformation, the minor-loop-gain matrix has four items. How to deal with the minor-loop-gain matrix induced different stability criterions [25]-[32], where the more convictive mathematical analysis and derivation on these stability criterions need be further explored. In addition, for a three-phase unbalanced AC DPGS, till now, no effective stability criterion in the dq frame has been deeply investigated [33].

Except that in the dq frame, the impedance-based stability analysis is also studied in the stationary frame[24], [33]. Based on the engineering experience, as long as the switching frequency of the inverters is much higher than the line frequency of 50 / 60 Hz, the small-signal analysis can be simplified. This concept has been widely accepted in the controller design of the inverters [33]-[36].

In fact, in the linear-control-based grid-tied inverter, the system stability assessment effect of the impedance-based stability analysis is almost equal to that of the Bode diagram analysis. The impedance-based stability analysis focuses on the interaction between the grid equivalent impedance and the

output impedance of local grid-tied inverter, while the Bode diagram analysis emphasizes on the stability of whole system with the equivalent grid impedance included [18]. Compared with the Bode diagram analysis, the merit of the impedance-based stability analysis is that the impedance of grid can be tested or estimated online. However, till now, the impedance-based stability analysis has not defined the universal quantitative stability indexes for the AC system, for instance, like the phase margin and the gain margin of Bode diagram analysis.

In theory, the impedance-based stability analysis should sample the information of grid impedance online. However, the measured grid impedance may not be reliable, due to possible harmonics voltages at the PCC. Currently, it is difficult to apply the impedance-based stability for deriving the design guidelines for designing the controller of the converters in a quantitative way. Nevertheless, it is still a useful tool to qualitatively analyze how to enhance the stability of AC DPGS. For example, as shown in Fig. 2, Z_o , Z_g or both Z_o and Z_g can be reshaped to ensure the stability of the local *LCL*-filter-based current-control grid-tied inverter, and thereby to enhance the stability of the AC DPGS.

III. INVERTER-SIDE DAMPING MEASURES

The inverter-side damping measures can reshape the output impedance Z_o to ensure the stability of grid-tied inverters, which mainly include the online grid impedance estimation methods, the inherent-damping methods, the passive damping methods, the active damping methods, and the hybrid damping methods.

A. Online Grid Impedance Estimation

In theory, as long as the grid impedance Z_g can be estimated accurately and timely, the control parameters can be adjusted online to modify Z_o , and thereby to keep system stable under any grid condition [2],[18]. In order to estimate the variation of grid parameters, a large number of online estimation methods have been proposed [37]-[50]. According to the realization mode, these methods can be classified into three groups. They are active, passive, and quasi-passive approaches.

The active estimation methods deliberately disturb the grid and extract the feedback information to estimate the grid impedance, including the non-characteristic harmonic injection [37], the broadband signal injection [38], the *LCL*-resonance excitation [39], the reactive power variation method [40], [41].

The passive estimation methods [42]-[50] are based on the direct measurement and evaluation of the grid information. The least-square estimation algorithm [42], the successive approximation estimation [43], the inherent switching feature application [44], and the plant time constant identification algorithm [45] are often adopted.

The quasi-passive estimation methods [51], [52] are also proposed, being combined with the non-intrusive advantage of passive estimation method and the accuracy of active estimation method. In this method, the passive estimation is first selected to estimate the grid impedance. When a selected evaluation index is exceeded, it will turn to the active estimation online.

Note that the accuracy of grid impedance estimation method is still inevitably influenced by the harmonics generated by other grid-tied inverters at the same PCC. The online grid impedance estimation need be further improved on the accuracy, the detection speed and also the anti-interference ability. Currently, grid impedance estimation method cannot be independently applied to grid-tied inverters, but it can be adopted as an additional method to enhance the stability of grid-tied inverter [53], [54].

B. Inherent-Damping (ID)

The digital time delay induces the inherent-damping effect into the current control loop [55]-[60], while the damping effect depends on where the current is sensed and what the delay time is set as. Ref. [56] studied the damping characteristic of time delay in a grid-current-feedback-based single-loop control system. Ref. [57]-[59] discussed the inherent-damping region of grid-tied inverter. Ref. [60] summarized the previous research and derived the time delay region which can stabilize the single-loop control system using different current feedback methods. As introduced in [60], when inverter-side-inductor current feedback is adopted, the related time delay should satisfy

$$\begin{cases} T_d < \frac{\pi}{2\omega_{\text{res}}}, (k=0) \\ \frac{(4k-1)\pi}{2\omega_{\text{res}}} < T_d < \frac{(4k+1)\pi}{2\omega_{\text{res}}} (k=1,2,\dots) \end{cases} \quad (2)$$

where T_d is the total time delay and $\omega_{\text{res}} = 2\sqrt{(L_1 + L_2 + L_g) / L_1(L_2 + L_g)C}$ is the filter resonance frequency in rad per second, L_1 is the inverter-side inductor, L_2 is the grid-side inductor, L_g is the grid inductor and C is the filter capacitor.

When the grid-side-inductor current feedback is used, the related time delay should satisfy

$$\frac{(4k+1)\pi}{2\omega_{\text{res}}} < T_d < \frac{(4k+3)\pi}{2\omega_{\text{res}}}, (k=0,1,2,\dots) \quad (3)$$

Based on the forgoing research, two key points on adopting the inherent-damping technique should be pointed out as follows,

1. When the equivalent grid impedance changes, the filter resonance frequency cannot shift across the critical frequency, which is defined as

$$f_{\text{crit}} = 1 / (4\tau T_s) \quad (4)$$

where τT_s is the total delay, including the computational delay and the PWM delay.

2. If the cable is long enough, the system may have multi-resonance peaks, where gains are over 0 dB due to the distributed capacitances [61],[62]. In this scenario, equation (2) or (3) should be satisfied at every resonant frequency.

It is also difficult to independently apply the inherent-damping technique in a current-controlled inverter, when the equivalent grid impedance varies and the multi-resonance peaks appear.

C. Passive Damping (PD)

A PD is easy to be implemented and it has been widely used in industrial applications [63]-[67]. The parameter design of the PD is based on the physical characteristics of system, such as the resistive region [65] and the Q-factor [66]. Main kinds of PDs have been illustrated in Fig. 3, where L_f is

the trap inductor for $LLCL$ -filter. As shown in Fig. 3, a resistor or resistors are necessarily inserted to damp the possible resonance, therefore, resulting in extra power losses.

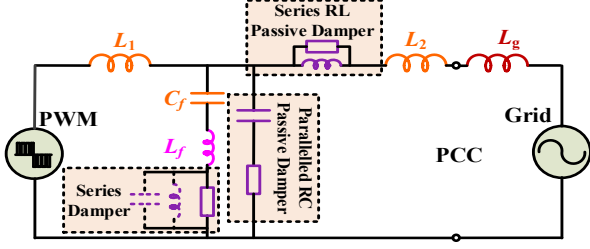

Fig. 3. Possible passive damping methods of grid-tied inverter.

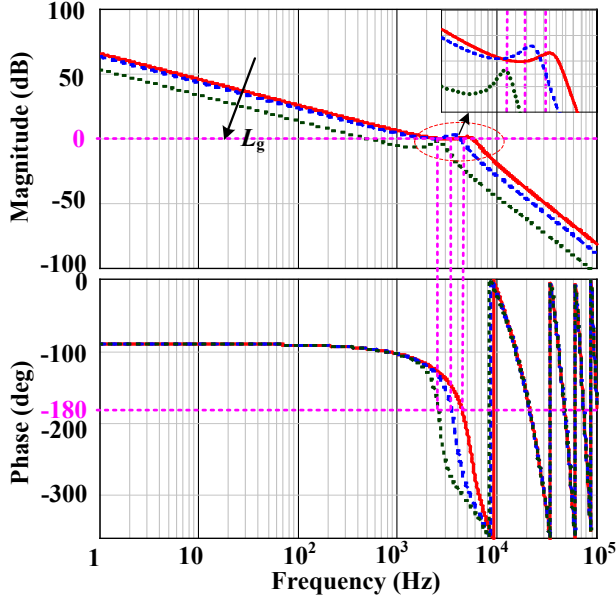

Fig. 4. Open-loop gain $i_g(s)/i_{gref}(s)$ of the LCL -filter based grid-tied inverter with the RC -damper.

Fig. 4 shows the open loop Bode diagram of $i_g(s)/i_{gref}(s)$ for an grid-tied inverters with only RC -passive damping [65],[18]. Based on Fig. 4, it can be deduced that a single PD-based system cannot achieve a high bandwidth in weak grid. A composite PD method can deal well with the difficulty caused by variable equivalent grid impedance, but at the cost of more materials, as well as more damping power losses [66].

D. Active Damping (AD)

Comparing with the PDs, the ADs [57], [68]-[86] earn more and more attentions due to flexibility and no extra damping power losses, although they will increase the control complexity and costs of the sensors [69]. There are two main types of ADs, including the single-loop ADs and the multi-loop ADs. The ADs can be seen as special cases of the state-feedback based control. Fig. 5 shows the control block of the LCL -filter based grid-tied inverter using the digital filter and the active damping with capacitor-current-feedback, where $G_h(s)$ is the zero-order-hold delay and $G_d(s)$ is the computational delay, $1/T_s$ represents the sampler and T_s is the sampling period, G_{inv} is the inverter gain, K_{ic} and K_{ig} are the feedback constants of the capacitor current and the grid current respectively, $G_c(s)$ is the proportional controller, and $H_{dig}(s)$ is the digital filter.

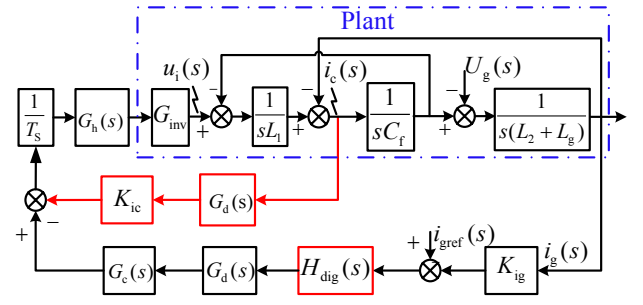

Fig. 5. Control diagram of LCL -filter-based grid-tied inverter using the digital filter and the active damping method with capacitor-current-feedback.

As shown in Fig. 5, when $K_{ic} = 0$, the single-loop control AD is obtained. The digital filter $H_{dig}(s)$ used in single-loop control mainly consists of the notch filter, the lead-lag network, and the bi-quad filter [70]. Ref. [71] proposed a self-commissioning notch filter to deal with the variation of the equivalent grid impedance. However, this method still relies on the accuracy of the real-time resonance frequency estimation, which is also inevitably disturbed by harmonics at the PCC. Ref. [72] suggested a kind of digital notch filter-based active damping technique, where the notch frequency is placed on the purpose away from the nominal resonant frequency of the LCL -filter. Nevertheless, if the multi-resonance peaks appear, this damping method may cease to be in effect.

The multi-loop ADs include the virtual resistor [73]-[75], the capacitor current feedback [76]-[81], the capacitor voltage feedback [82]-[85], and the LC -trap voltage feedback [86].

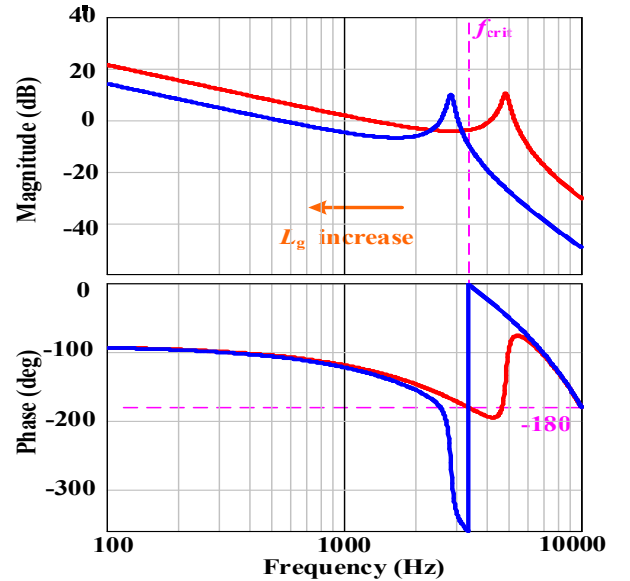

Fig. 6. Open loop gain $i_g(s)/i_{gref}(s)$ of system using the capacitor current feedback damping method.

Fig. 6 depicts the open loop gain $i_g(s)/i_{gref}(s)$ of the current-controlled inverters with capacitor current feedback damping method only. It can be seen that when the characteristic frequency of system is higher than the critical frequency, the non-minimum-phase response of system emerges due to the appearance of right half plane poles, which inevitably complicates the controller design.

Many papers have proposed different kinds of methods to modify the capacitor current feedback AD. Ref. [78]

proposed a real-time computational method to reduce the computational delay, which can simplify the closed loop design and improve the system performance effectively. But when the grid voltage has much harmonics or other reasons to make the duty-cycle of grid-tied inverter vary sharply, this method cannot work well. Refs. [73] and [80] aimed to increase the critical frequency from $1/(6T_s)$ to $1/(4T_s)$ or $1/(3T_s)$ by modifying the feedback loop, where the damping region can be widened. However, the high pass filter inserted in the capacitor current feedback inner loop [73] will easily enlarge the high frequency noise interference and the proposed optimal damping coefficient in [80] cannot be derived precisely.

In order to ensure the stability of system when the filter resonance frequency changes across the critical frequency of f_{crit} , ref. [76] modified the capacitor current feedback AD by inserting a phase-lag component in the control loop. With a 0.75 switching frequency digital delay, this method can keep the system stable, when the equivalent grid impedance varies widely. However, the phase margin of system is not big enough when the characteristic frequency appears around the critical frequency. Ref. [79] proposed the forbidden frequency region of $((1-\xi)f_{crit}, (1+\xi)f_{crit})$ to ensure enough phase margin, where ξ is the coefficient of forbidden region. Nevertheless, when the filter resonance frequency is rigidly less than $(1-\xi)f_{crit}$, the bandwidth of system can hardly keep high in weak grid. When the filter resonance frequency is rigidly limited in the range of $((1+\xi)f_{crit}, 1/(2T_s))$, the parameter design of *LLCL*-filter is difficult to ensure a enough phase margin when the equivalent grid impedance varies widely.

Like the capacitor-current-feedback active damping method, the derivative feedback of the capacitor voltage can also induce an effective active damping [82]-[84]. Based on using an *LLCL*-filter, [86] compared the capacitor current feedback AD with the *LC*-trap voltage AD, and found that the *LC*-trap voltage feedback AD has a wider damping region. However, since the grid-voltage may change suddenly and widely, it is difficult to choose a suitable feedback coefficient to ensure a satisfactory damping effect under the different condition of grid voltage.

Further, similar to the inherent damping method, if the multi-resonance peaks appear due to the distributed capacitance of cable, a single AD (whether for a single-loop AD or a multi-loop AD) may lose effectiveness, especially when the equivalent grid impedance varies in a wide range and the grid background harmonics are abundant.

E. Hybrid Damping (HD)

The Hybrid Damping (HD) techniques were discussed in [18], [87], [88]. They make a trade-off between the power losses and the damping robustness of system. Ref. [87] proposed a hybrid damper using a resistor in series with the filter capacitor together with the capacitor current feedback control, where the extra damping losses may be high. The *RC*-damper is preferred to be implemented in the HD, owing to the small extra power losses [18], [67], [88].

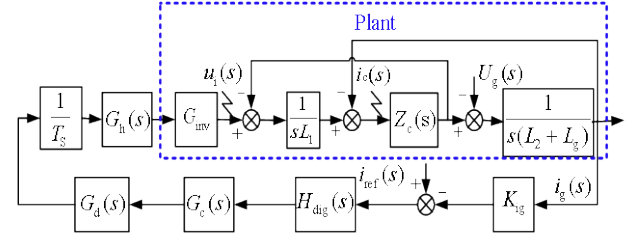

Fig. 7. Control block of the hybrid damper composed of the *RC* PD and the digital filter AD [18].

Ref. [18] combined the *RC*-damper with the digital notch filter to damp the resonance caused by *LLCL*-filter and the control diagram is redrawn in Fig. 7, where

$$Z_c(s) = \frac{(R_d C_d s + 1)(L_f C_f s^2 + 1)}{L_f C_f C_d s^3 + R_d C_d C_f s^2 + (C_d + C_f)s}, \quad (5),$$

and R_d and C_d are the paralleled passive damping resistor and capacitor respectively. A high control bandwidth can be achieved, when the equivalent grid impedance varies widely. Therefore, a proportion plus resonant regulator can easily be adopted to attenuate the low frequency grid background harmonics.

IV. GRID-SIDE DAMPING MEASURES

Based on the impedance-based stability analysis, it can be seen that the local grid-tied inverter can keep stable through reshaping the equivalent grid impedance Z_g , which can be regulated by using the centralized damping approaches as shown in Fig. 8.

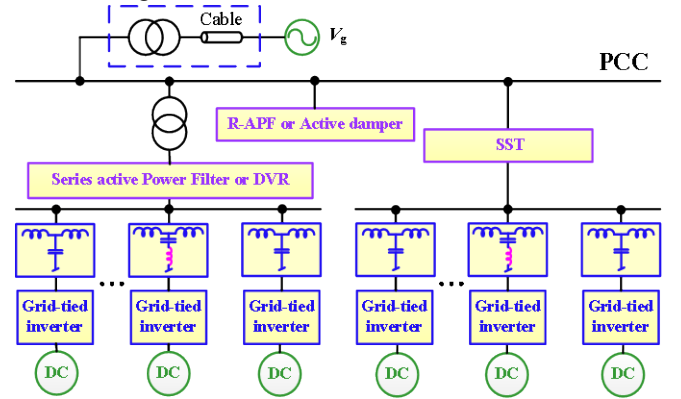

Fig. 8. Centralized damping approaches to reshape Z_g .

The grid-side damping measures can be realized by adopting the resistive active power filter, the solid state transformer, the series active filter, the dynamic voltage restorer, and so on.

A. Resistive Active Power Filter

The Resistive Active Power Filter (*R-APF*) method was proposed to attenuate the harmonic propagation [93]-[95]. Researches on the control or the installation site of the *R-APF* were carried out in the past few years. Ref. [96] developed a discrete tuning method to adjust the equivalent resistor, corresponding to voltage distortion. According to [93], the *R-APF* is preferred to be installed at the end bus of the distribution line, acting as a resistor to mitigate harmonics. For a long distance power distribution feeder, the voltage harmonics are mitigated at the point of installation of the active power filter, whereas harmonics may be magnified in other buses, where no filter is connected [96],[97]. Generally,

the *R-APF* cannot provide direct voltage support during microgrid islanded mode, so [98] proposed a virtual impedance method to mitigate the resonance propagation in both grid-tied and islanded modes, by using a microgrid resonance propagation model.

The resonance propagation through the transmission line will also lead to the instability. Based on the harmonic propagation concept, if the resonance frequency is outside of the control bandwidth of the local power inverter, the resonance propagation attenuation can also be realized by using the *R-APF* or the active damper [99]. The active damper generally operates at high frequency. Therefore, a high control bandwidth can be obtained to suppress the middle or the high frequency resonance. In order to reduce the blocked voltage of the devices, ref. [100] adopted a serial *LC*-based structure, but at the cost of more passive components. Further, Due to the limitation of the power rating and the serial *LC*-filter, this method can only regulate the characteristic of Z_g in a special frequency range. The function of the active damper can also be realized by the local inverter [92].

B. Solid State Transformer

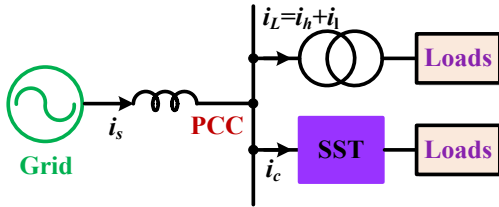

Fig. 9. Solid state transformer utilization in harmonic compensation [103].

Besides the *R-APF* or the active damper, the Solid State Transformer (SST) is becoming attractive in stabilizing the power system and improving the grid power quality [101]-[107]. Compared with the traditional line power transformer, the SST was proposed to achieve the voltage transformation with the medium or the high-frequency isolation, which potentially can reduce the volume and the weight. The SST can possess the active harmonic filtering function [103] as seen in Fig. 9, where i_s is the grid-injected current, i_L is the load current, i_1 is the load fundamental current, i_h is the harmonic component, and i_c is the compensating current. When $i_c = -i_h$, the harmonic can be totally absorbed. However, the switching frequency of SST limits the control bandwidth.

In addition, compared with the traditional transformer, a proper designed SST can improve the stability of subsystem, since it can decrease its absolute output impedance in the branch as shown in Fig. 9.

C. Other Possible Methods

A series active power filter can be connected at the PCC to damp the resonance effectively [108]. Note that, due to the installation limitation and the economy reason, the popularity of series active power filter is not so high, where it may be replaced with SST in some day.

When many constant power loads, like the active rectifier loads with the high control bandwidth, are connected at the PCC, the stability of DPGS will be challenged due to the negative incremental resistor of constant power load [23]. A dynamic voltage restorer can compensate the dynamic voltage changing [109], [110], therefore it can enhance the stability of DPGS. However, similar to the series active power filter, the series structure is not so popular and it can also be replaced with the SST in future.

As previously mentioned, the regulation of Z_g is also an effective and attractive method to stabilize the system. Nevertheless, the economic performance of difference method should be fully evaluated. In present, due to the economic consideration, seldom of grid-side damping methods have been widely applied in industrial applications.

V. KEY DESIGN POINTS, PERFORMANCE EVALUATION, AND DAMPING ROBUSTNESS

A. Design Key Pinots and Performance Evaluation

According to the impedance-based stability analysis, the output impedance of the current-controlled grid-tied inverter is expected to bigger enough. Within the control bandwidth, the output impedance of the grid-tied inverter depends on both the filter parameters and the loop gain [23]. A higher control bandwidth will help to enlarge the output impedance Z_o .

The delay reduction technique is a great method to improve the control bandwidth of the current-controlled grid-tied inverter [18]. This can be realized by using the multi-sample techniques [111]-[113] or the other optimization methods [58], [75], [78].

Besides the delay reduction, there are also some other key points in the parameter design of different inverter-side damping methods, which are summarized in Table I. In order to help researches and engineers to know about these different damping techniques in detail, the performance analysis on classical damping methods is carried out, while several indexes and comparative results are listed in Table II.

B. Discussion on Damping Robustness of Classic Methods in Industrial Applications

Generally, in an AC DPGS, the damping robustness of classic damping methods can be ensured, if the distributed capacitance of cable can be ignored.

Note that in industrial applications, the impedance characteristic of local grid-tied inverter is still influenced by the distributed impedance of the cable [61],[62], especially when the cable is long enough. In this scenario, due to the complicated characteristic of filter, the inherent damping method may be not so reliable. Similarly, for the capacitor current feedback AD, if the cable is long enough, multi-resonance peaks may appear and the stability of system will be challenged. However, for the passive damping or passive damping based hybrid damping method, if the resonance at the domain characteristic frequency of system is

Table I. Key points in the parameter design of inverter-side damping methods

	Inherent Damping (ID)	Passive Damping (PD)	Active Damping (AD)		Hybrid Damping (HD)
			Single loop	Multiloop	

Main Characteristic or Requirement	When the filter resonance frequency f_r satisfies $f_r < f_{crit}$, the inverter side current feedback can stabilize the system with inherent damping method.	Suitable for the single phase low power system. The more power losses, the better damping effect. The RC -damper is preferred, where the damping capacitance of C_d had better be equal to the filter capacitance of C_f .	During application, this method is not very reliable if it is not combined with other methods.	Capacitor current feedback AD is preferred for a three-phase high-power system.	Compared with the PD method, the damping robustness with respect to the wide variation in Z_g is improved with HD.
	When $f_{crit} < f_r < 0.5f_{s,3}$, the grid-side current feedback can stabilize the system with the ID method.			Capacitor voltage feedback AD must deal with the challenge of grid voltage variation.	
Concern of Application	Check whether f_r changes across f_{crit} when Z_g varies.	Parameters of the RC damper can be defined as follows: $\frac{\sqrt{\lambda+1}}{\lambda} \sqrt{\frac{L_p}{C_f}} \leq R_d \leq \frac{\lambda+1}{\lambda} \sqrt{\frac{L_p}{C_f}}$ $\lambda = C_d / C_f$		Reduced delay can help the damping design, while the EMI noise needs to be especially addressed. Check whether f_r changes across f_{crit} .	If the grid impedance Z_g varies widely, the HD method should be the first choice, especially for a single-phase system.
Additional Description	$f_r = \frac{1}{2\pi} \sqrt{\frac{L_1 + L_2 + L_g}{L_1 C (L_2 + L_g)}}$	$L_p = L_1 L_2 / (L_1 + L_2)$ for LCL filter $L_p = L_1 L_2 / (L_1 + L_2) + L_r$ for $LLCL$ filter		When f_r is close to f_{crit} , system performance may not be satisfactory.	

Table II. Performance evaluation of classic inverter-side damping methods

	ID with inverter-side inductor current feedback	ID with grid-side inductor current feedback	PD using R damper	PD using RC damper	Capacitor current feedback AD 1 ($f_r < f_{crit}$)	Capacitor current feedback AD 2 ($f_{crit} < f_r < 0.5f_s$)	HD based on RC damper
Sensitive to Z_g	Middle	High	Low	Low	Middle	High	Low
Control bandwidth	Low	High	High	Middle	Low	High	High
Phase margin	Large	Small	Large	Middle	Large	Small	Middle
Extra initial investment	No	No	Cost of damping resistor	Cost of damping resistor	Cost of capacitor current sensor	Cost of capacitor current sensor	Cost of damping resistor
Extra damping power loss (%)	No	No	Less than 0.15%	Less than 0.05%	Almost no (sensor power loss)	Almost no (sensor power loss)	Less than 0.05%

suppressed enough, the higher frequency resonance is spontaneously attenuated, and thus the stability of local grid-tied inverter can also be ensured.

Based on the analysis above, it can be judged that compared with other damping methods, the robustness of the passive damping or passive damping based hybrid damping is higher, certainly at cost of more power losses.

VI. CONCLUSIONS

LCL -filter-based current-controlled grid-tied inverters are widely used in DPGSSs. These inverters may excite resonances, particularly when the equivalent grid impedance varies in a wide range. The impedance-based stability analysis method for qualitatively analyzing and assessing the stability of AC DPGSSs is widely accepted. However, how to use this method to guide the design of the grid-tied inverter in a quantitative manner needs to be explored further, particularly in an unbalanced three-phase system. Most published damping methods were comprehensively reviewed based on the concept of impedance-based stability and

classified into two main categories: inverter-side and grid-side measures.

The inverter-side damping measures can be seen to ensure the stability of system by reshaping the output impedance of local grid-tied power inverter itself. The grid-side damping measures try to reshape the equivalent grid impedance to stabilize the whole system. Certainly, two kinds of impedance reshaping methods can both be adopted at the same time, to make AC DPGSS more stable.

All the grid-side damping measures belong to the centralized damping method, where the extra equipment should be adopted. Therefore, currently they are not so popular to customers.

The key pinots in the parameter design of classic inverter-side damping methods are summarized in Table I. The performance evaluation results are given in Table II. And the damping robustness analysis and discussion have been performed. Based on these, two application suggestions on inverter-side damping methods can be obtained as following,

1. In a single phase or a low power rating three phase grid-tied inverter application, the RC -damper-based

single-loop hybrid damping method is first suggested to be adopted.

2. For the high power rating three-phase system application, the capacitor current feedback AD is preferred. Further, if the connected cable is long enough (for example, longer than 500m), an additional RC-damper had better be inserted to dampen possible high frequency resonances caused by the cable or capacitive loads at the PCC.

Some of future trends in this topic are,

1. Researches on the impedance-based stability analysis and the stability criterion should be further strengthened. For example, the convective mathematical analysis on the conservatism of criterions, the effect caused by the coupling impedance in an unbalance system, the relationship of tested impedances in different kinds of reference frame, and even the universal quantitative stability indexes should be further explored.
2. The online parameter estimation has not yet been successfully adopted for the resonance attenuation independently. It is with high potentiality for future applications, since the computing capacity of controller processor is becoming more and more powerful and thereby smart complicated algorithms can be realized together with an acceptable cost. Moreover, the explored estimation method can also be used as an additional measure in the control design of grid-tied inverter.
3. The inverter-side damping measures introduced in this paper are mainly based on the linear control strategy. In fact, many nonlinear controls have also been applied in the grid-tied inverters. In these cases, the output impedance Z_o will have a dynamic and changeable value. Due to the length of this paper, the nonlinear control strategy has not been introduced here. However, nonlinear control methods should inevitably earn more concerns, due to more and more powerful controller processors, therefore many nonlinear algorithms can be realized at acceptable costs in some day.
4. More attentions should be paid on the damping technique of the multi-function-based SST, since it can integrate functions of the dynamic voltage regulation, the active filtering, the energy storage conversion, the power density enhancement, and the power flow regulation together. In the future, the SST will be applied in the AC DPGS.

References

- [1] F. Blaabjerg, R. Teodorescu, M. Liserre, and A. V. Timbus, "Overview of control and grid synchronization for distributed power generation systems," *IEEE Trans. Ind. Electron.*, vol. 53, no. 5, pp. 1398–1409, Oct. 2006.
 - [2] M. Liserre, R. Teodorescu, and F. Blaabjerg, "Stability of photovoltaic and wind turbine grid-connected inverters for a large set of grid impedance values," *IEEE Trans. Power Electron.*, vol. 21, no. 1, pp. 263–272, Jan. 2006.
 - [3] X. Wang, F. Blaabjerg, and W. Wu, "Modeling and Analysis of Harmonic Stability in an AC Power-Electronics-Based Power System," *IEEE Trans. Power Electron.*, vol. 29, no. 12, pp. 6421–6432, Dec. 2014.
 - [4] Z. Bai, H. Ma, D. Xu, B. Wu, Y. Fang, and Y. Yao, "Resonance Damping and Harmonic Suppression for Grid-Connected Current-Source Inverter," *IEEE Trans. Ind. Electron.*, vol. 61, no. 7, pp. 3146–3154, Jul. 2014.
 - [5] IEEE Application Guide for IEEE Std. 1547, IEEE Standard for Interconnecting Distributed Resources With Electric Power Systems, *IEEE1547.2-2008*, 2008.
 - [6] IEEE Recommended Practices and Requirements for Harmonic Control in Electrical Power Systems, *IEEE Standard 519-1992*, 1992.
 - [7] M. Liserre, F. Blaabjerg, and S. Hansen, "Design and control of an LCL-filter-based three-phase active rectifier," *IEEE Trans. Ind. Appl.*, vol. 41, no. 5, pp. 1281–1291, Sept./Oct. 2005.
 - [8] W. Wu, Y. He, and F. Blaabjerg, "An LLCL Power Filter for Single-Phase Grid-Tied Inverter," *IEEE Trans. Power Electron.*, vol. 27, no. 2, pp. 782–789, Feb. 2012.
 - [9] W. Wu, Y. J. Sun, Z. Lin, Y. He, X. F. Wang, F. Blaabjerg and H. Chung, "A Modified LLCL Filter With the Reduced Conducted EMI Noise," *IEEE Trans. Power Electron.*, vol. 29, no. 7, pp. 3393–3402, Jul. 2014.
 - [10] P. Alemi, C. Bae and D. Lee, "Resonance Suppression Scheme Based on PR control for Single-Phase Grid-Connected Inverters with LLCL Filters," *IEEE J. Emerging Sel. Topics Power Electron.*, vol. 4, no. 2, pp. 459–467, Jun. 2016.
 - [11] J. Miret, M. Castilla, J. Matas, J. M. Guerrero and J. C. Vasquez, "Selective Harmonic-Compensation Control for Single-Phase Active Power Filter With High Harmonic Rejection," *IEEE Trans. Ind. Electron.*, vol. 56, no. 8, pp. 3117–3127, Aug. 2009.
 - [12] J.L. Agorreta, M. Borrega, J. Lopez, and L. Marroyo, "Modeling and Control of N-Paralleled Grid-Connected Inverters With LCL Filter Coupled Due to Grid Impedance in PV Plants," *IEEE Trans. on Power Electron.*, vol. 26, no. 3, pp. 770–785, Mar. 2011.
 - [13] J. Enslin and P. Heskens, "Harmonic interaction between a large number of distributed power inverters and the distribution network," *IEEE Trans. Power Electron.*, vol. 19, no. 6, pp. 1586–1593, Nov. 2004.
 - [14] J. Rocabert, A. Luna, F. Blaabjerg and P. Rodriguez, "Control of Power Converters in AC Microgrids," *IEEE Trans. Power Electron.*, vol. 27, no. 11, pp. 4734–4749, May. 2012.
 - [15] M. Cespedes and J. Sun, "Impedance Modeling and Analysis of Grid-Connected Voltage-Source Converters," *IEEE Trans. Power Electron.*, vol. 29, no. 3, pp. 1254–1261, Mar. 2014.
 - [16] H. Wu, X. Ruan, D. Yang, X. Chen, W. Zhao, "Small-Signal Modeling and Parameters Design for Virtual Synchronous Generators," *IEEE Trans. Ind. Electron.*, vol. 63, no. 7, pp. 4292–4303, July 2016.
 - [17] J. Liu, Y. Miura and T. Ise, "Comparison of Dynamic Characteristics Between Virtual Synchronous Generator and Droop Control in Inverter-Based Distributed Generators," *IEEE Trans. on Power Electron.* vol. 31, no. 5, pp. 3600–3611, May 2016.
 - [18] Y. Liu, W. Wu, Y. He, Z. Lin, F. Blaabjerg and H. Chung, "An Efficient and Robust Hybrid Damper for LCL- or LLCL-based Grid-Tied Inverter with Strong Grid-side Harmonic Voltage Effect Rejection," *IEEE Trans. Ind. Electron.*, vol. 63, no. 2, pp. 926–936, Feb. 2016.
 - [19] R. D. Middlebrook, "Input filter considerations in design and application of switching regulators," in *Rec. 1976 IEEE Ind. Appl. Soc. Annu. Meeting*, pp. 366–382.
 - [20] X. Feng, J. Liu, and F. C. Lee, "Impedance specifications for stable DC distributed power systems," *IEEE Trans. Power Electron.*, vol. 17, pp. 157–162, 2002.
 - [21] P. Kundur, "Power System Stability and Control", *New York: McGraw-Hill*, 1994.
 - [22] M. Ilic and J. Zaborszky, Dynamics and Control of Large Electric Power Systems. *New York: Wiley*, 2000.
- ### Impedance-based stability criterion
- [23] M. Belkhatay, "Stability criteria for ac power systems with regulated loads," *Ph.D. dissertation, Purdue Univ., West Lafayette, In*, Dec. 1997.
 - [24] J. Sun, "Impedance-Based Stability Criterion for Grid-Connected Inverters," *IEEE Trans. Power Electron.*, vol. 26, no. 11, pp. 3075–3078, Nov. 2011.
 - [25] H. Mao, D. Boroyevich, and F. C. Lee, "Novel reduced-order small signal model of a three-phase PWM rectifier and its application in control design and system analysis," *IEEE Trans. Power Electron.*, vol. 13, no. 3, pp. 511–521, May 1998.
 - [26] B. Wen, D. Boroyevich, R. Burgos, P. Mattavelli and Z. Shen, "Small-Signal Stability Analysis of Three-Phase AC Systems in the Presence of Constant Power Loads Based on Measured d-q Frame Impedances," *IEEE Trans. Power Electron.*, vol. 30, no. 10, pp. 5952–5963, Oct. 2015.
 - [27] B. Wen, D. Boroyevich, R. Burgos, P. Mattavelli and Z. Shen, "Analysis of D-Q Small-Signal Impedance of Grid-Tied Inverters," *IEEE Trans. Power Electron.*, vol. 31, no. 1, pp. 675–687, Jan. 2016.
 - [28] B. Wen, "Stability Analysis of Three-phase AC Power Systems Based on Measured D-Q Frame Impedances," *Ph.D. dissertation, Virginia Polytechnic Inst. and State Univ., Blacksburg, Virginia*, Nov. 2014.
 - [29] B. Wen, D. Boroyevich, R. Burgos, P. Mattavelli and Z. Shen, "Inverse Nyquist Stability Criterion for Grid-Tied Inverters," *IEEE Trans. Power Electron.*, vol. 32, no. 2, pp. 1548–1556, Feb. 2017.
 - [30] F. Liu, J. Liu, H. Zhang and D. Xue, "Stability Issues of Z+Z Type Cascade System in Hybrid Energy Storage System (HESS)," *IEEE Trans. Power Electron.*, vol. 29, no. 11, pp. 5846–5859, Nov. 2014.
 - [31] Z. Liu, J. Liu, W. Bao and Y. Zhao, "Infinity-Norm of

Impedance-Based Stability Criterion for Three-Phase AC Distributed Power Systems With Constant Power Loads," *IEEE Trans. Power Electron.*, vol. 30, no. 6, pp. 3030-3043, Jun. 2015.

[32] M. Schweizer and J. W. Kolar, "Shifting input filter resonances - an intelligent converter behavior for maintaining system stability," *In Proc. Int. Power Electron. Conf. ECCE Asia*, May 2010, pp. 906-913.

[33] J. Sun, Z. Bing and K. J. Karimi, "Input Impedance Modeling of Multipulse Rectifiers by Harmonic Linearization," *IEEE Trans. Power Electron.*, vol. 24, no. 12, pp. 2812-2820, Dec. 2009.

[34] W. Wu, J. Ji and F. Blaabjerg, "Aalborg Inverter - A New Type of "Buck in Buck, Boost in Boost" Grid-Tied Inverter," *IEEE Trans. Power Electron.*, vol. 30, no. 9, pp. 4784-4793, Sept. 2015.

[35] W. Wu, H. Wang, Y. Liu, M. Huang and F. Blaabjerg, "A Dual-Buck-Boost AC/DC Converter for DC Nanogrid With Three Terminal Outputs," *IEEE Transactions on Ind. Electron.*, vol. 64, no. 1, pp. 295-299, Jan. 2017.

[36] Z. Zhao, M. Xu, Q. Chen, J. Lai, and Y. Cho, "Derivation, analysis, and implementation of a boost-buck converter-based high-efficiency PV inverter," *IEEE Trans. Power Electron.*, vol. 27, no. 3, pp. 1304-1313, Mar. 2012.

Online parameter estimation

Active estimation method

[37] A.V. Timbus, R. Teodorescu, F. Blaabjerg, and U. Borup, "Online grid measurement and ENS detection for PV inverter running on highly inductive grid," *IEEE Trans. Power Electron.*, vol. 2, no. 3, pp. 77-82, Sept. 2004.

[38] T. Roinila, M. Vilkkö, and J. Sun, "Online Grid Impedance Measurement Using Discrete-Interval Binary Sequence Injection," *IEEE J. Emerging Sel. Topics Power Electron.*, vol. 2, no. 4, pp. 985-993, Dec. 2014.

[39] M. Liserre, F. Blaabjerg, and R. Teodorescu, "Grid impedance estimation via excitation of LCL-filter resonance," *IEEE Trans. Ind. Appl.*, vol. 43, no. 5, pp. 1401-1407, Sep./Oct. 2007.

[40] A.V. Timbus, P. Rodriguez, R. Teodorescu, and M. Ciobotaru, "Line Impedance Estimation Using Active and Reactive Power Variations," in *Proc. IEEE PES*, Orlando, FL, America, Jun. 17-21, 2007, pp. 1273-1279.

[41] M. Ciobotaru, R. Teodorescu, P. Rodriguez, A. Timbus, and F. Blaabjerg, "Online grid impedance estimation for single-phase grid-connected systems using PQ variations," in *Proc. IEEE PES*, Orlando, FL, America, Jun. 17-21, 2007, pp. 2306-2312.

Passive estimation method

[42] S. Cobrecas, E.J. Bueno, D. Pizarro, F.J. Rodriguez, and F. Huerta, "Grid Impedance Monitoring System for Distributed Power Generation Electronic Interfaces," *IEEE Trans. Instrum. Meas.*, vol. 58, no. 9, pp. 3112-3121, Sep. 2009.

[43] S. Cobrecas, P. Rodriguez, D. Pizarro, F. J. Rodriguez, and E. J. Bueno, "Complex-space recursive least squares power system identification," in *Proc. of PES*, Orlando, FL, America, Jun. 17-21, 2007, pp. 2478-2484.

[44] M. Ciobotaru, V. Agelidis, and R. Teodorescu, "Line impedance estimation using model based identification technique," in *Proc. IEEE EPE2011*, Birmingham, UK, Aug. 30-Sep. 1, 2011, pp. 1-9.

[45] H. Gu, X. Guo, D. Wang, and W. Wu, "Real-time grid impedance estimation technique for grid-connected power inverters," in *Proc. IEEE ISIE2012*, Hangzhou, China, May. 28-31, 2012, pp. 1621-1626.

[46] A. Vidal, A. G. Yepes, F. D. Freijedo, Ó. López, J. Malvar, F. Baneira, and J. Doval-Gandoy, "A Method for Identification of the Equivalent Inductance and Resistance in the Plant Model of Current-Controlled Grid-Tied Inverters," *IEEE Trans. Power Electron.*, vol. 30, no. 12 pp. 7245-7261, Dec. 2015.

[47] K. O. H. Pedersen, A. H. Nielsen, and N. K. Poulsen, "Short-circuit impedance measurement," *IEE Proceedings-Generation, Transmission and Distribution*, vol. 150, pp. 169-174, 2003.

[48] A. Bien, D. Borkowski, and A. Wetula, "Estimation of power system parameters based on load variance observations - laboratory studies," in *Proc. of EPQU*, Barcelona, Spain, Oct. 9-11, 2007, pp. 1-6.

[49] N. Hoffmann and F. Fuchs, "Minimal invasive equivalent grid impedance estimation in inductive-resistive power networks using extended Kalman filter," *IEEE Trans. Power Electron.*, vol. 29, no. 2, pp. 631-641, Feb. 2014.

[50] R. N. Beres, X. Wang, F. Blaabjerg, M. Liserre and C. L. Bak, "Optimal Design of High-Order Passive-Damped Filters for Grid-Connected Applications," *IEEE Trans. Power Electron.*, vol. 31, no. 3, pp. 2083-2098, Mar. 2016.

Quasi-passive estimation method

[51] M.J.-B. Ghorbal, W. Ghzail, I. Slama-Belkhdja, and J.M. Guerrero, "Online detection and estimation of grid impedance variation for Distributed Power Generation," in *Proc. IEEE MELECON*, Yasmine Hammamet, Tunisie, Mar. 25-28, 2012, pp. 555-560.

[52] H. Berriri, M.W. Naouar, and I. Slama-Belkhdja, "Easy and Fast Sensor Fault Detection and Isolation Algorithm for Electrical Drives," *IEEE Trans. Power Electron.*, vol. 27, no. 2, pp. 490-499, Feb. 2012.

[53] Y. He, H. Chung, C. N. M. Ho, W. Wu, "Direct Current Tracking Using Boundary Control with Second-Order Switching Surface for

Three-Phase Three-Wire Grid-Connected Inverter," *IEEE Trans. Power Electron.*, vol. PP, no.99, pp.1-1

[54] Y. He, H. S. H. Chung, C. N. M. Ho, W. Wu, "Modified Cascaded Boundary-Deadbeat Control for a Virtually-Grounded Three-Phase Grid-Connected Inverter with LCL Filter," *IEEE Trans. Power Electron.*, vol. PP, no.99, pp.1-1

Inverter-side-damping measures

Inherent-damping

[55] Y. Tang, P. C. Loh, P. Wang, F. H. Choo, and F. Gao, "Exploring inherent damping characteristic of LCL-filters for three-phase grid-connected voltage source inverters," *IEEE Trans. Power Electron.*, vol. 27, no. 3, pp. 1433-1443, Mar. 2012.

[56] J. Yin, S. Duan, and B. Liu, "Stability Analysis of Grid-Connected Inverter with LCL Filter Adopting A Digital Single-Loop Controller with Inherent Damping Characteristic," *IEEE Trans. Ind. Inf.*, vol. 9, no. 2, pp. 1104-1112, May. 2013.

[57] S. G. Parker, B. P. McGrath, and D. G. Holmes, "Regions of Active Damping Control for LCL Filters," *IEEE Trans. Ind. Appl.*, vol. 50, no. 1, pp. 424-432, Jan./Feb. 2014.

[58] C. Zou, B. Liu, S. Duan, and R. Li, "Influence of Delay on System Stability and Delay Optimization of Grid-Connected Inverters With LCL Filter," *IEEE Trans. Ind. Inf.*, vol. 10, no. 3, pp. 1775-1784, Aug. 2014.

[59] Y. Tang, C. Yoon, R. Zhu, and F. Blaabjerg, "Generalized stability regions of current control for LCL-filtered grid-connected inverters without passive or active damping," in *Proc. of IEEE Energy Conversion Congress and Exposition*, Montreal, Canada, 2015, pp. 2040-2047.

[60] J. Wang, J. Yan, L. Jiang, and J. Zou, "Delay-Dependent Stability of Single-Loop Controlled Grid-Connected Inverters with LCL Filters," *IEEE Trans. Power Electron.*, vol. 31, no. 1, pp. 743-757, Jan. 2016.

[61] S. Zhang, S. Jiang, X. Lu, B. M. Ge, and F. Z. Peng, "Resonance issues and damping techniques for grid-connected inverters with long transmission cable," *IEEE Trans. Power Electron.*, vol. 29, no. 1, pp. 110-120, Jan. 2014

[62] Y. Jiang, W. Wu, Y. He, H. S. h. Chung, F. Blaabjerg, "A New Passive Filter Design Method for Overvoltage Suppression and Bearing Currents Mitigation in a Long Cable Based PWM Inverter-Fed Motor Drive System," *IEEE Trans. Power Electron.*, vol. PP, no.99, pp.1-1.

Passive damping

[63] R. Beres, X. Wang, F. Blaabjerg, M. Liserre and C.L. Bak, "A Review of Passive Power Filters for Three-Phase Grid-Connected Voltage-Source Inverters," *IEEE Trans. Power Electron.*, vol. 4, no. 1, pp. 54-69, Mar. 2016.

[64] A.K. Balasubramanian and V. John "Analysis and design of split-capacitor resistive inductive passive damping for LCL filters in grid-connected inverters," *IET, Power Electron.*, vol. 6, no. 9, pp. 1822-1832, Nov. 2013.

[65] W. Wu, Y. He, T. Tang, F. Blaabjerg, "A New Design Method for the Passive Damped LCL- and LCL-Filter Based Single-Phase Grid-tied Inverter," *IEEE Trans. Ind. Electron.*, vol. 60, no. 10, pp. 4339-4350, Oct. 2013.

[66] W. Wu, Y.J. Sun, M. Huang, X.F. Wang, H. Wang and F. Blaabjerg, "A Robust Passive Damping Method for LLCL-Filter-Based Grid-Tied Inverters to Minimize the Effect of Grid Harmonic Voltages," *IEEE Trans. Power Electron.*, vol. 29, no. 7, pp. 3279-3289, Jul. 2014.

[67] R. P. Alzola, M. Liserre, F. Blaabjerg, R. Sebastián, J. Dannehl, and F.W.Fuchs, "Analysis of the passive damping losses in LCL-filter-based grid inverters," *IEEE Trans. Power Electron.*, vol. 28, no. 6, pp. 2642-2646, Jun. 2013.

Active damping

[68] M. Hanif, V. Khadkikar, W. Xiao, and J. L. Kirtley, "Two degrees of freedom active damping technique for filter-based grid connected PV systems," *IEEE Trans. Ind. Electron.*, vol. 61, no. 6, pp. 2795-2803, Jun. 2014.

[69] B. Bahrani, M. Vasiladiotis and A. Rufer, "High-Order Vector Control of Grid-Connected Voltage-Source Inverters with LCL-Filters," *IEEE Trans. Ind. Electron.*, vol. 61, no. 6, pp. 2767-2775, Jun. 2014.

[70] J. Dannehl, M. Liserre and F. Fuchs, "Filter-based active damping of voltage source inverters with LCL filters," *IEEE Trans. Ind. Electron.*, vol. 58, no. 8, pp. 3623-3633, Oct. 2011.

[71] R. P. Alzola, M. Liserre, F. Blaabjerg, R. Sebastián, T. Kerekes. "Self-commissioning Notch Filter for Active Damping in Three Phase LCL-filter Based Grid Inverters," *IEEE Trans. Power Electron.*, vol.29, no.12, pp. 6754-6761, Dec. 2014.

[72] W. Yao, Y. Yang, X. Zhang, F. Blaabjerg, and P. C. Loh, "Design and Analysis of Robust Active Damping for LCL Filters using Digital Notch Filters," *IEEE Trans. Power Electron.*, vol. 32, no. 3, pp. 2360-2375, March 2017.

[73] X. Wang, F. Blaabjerg, P. C. Loh, "Virtual RC Damping of LCL-Filtered Voltage Source Inverters with Extended Selective Harmonic Compensation," *IEEE Trans. Power Electron.*, vol. 30, no. 9, pp. 4726-4737, Sept. 2010.

- [74] X. Wang, X. F. Blaabjerg, P. C. Loh, "Grid-Current-Feedback Active Damping for LCL Resonance in Grid-Connected Voltage Source Inverters," *IEEE Trans. Power Electron.*, vol.3, no.1, pp. 213-223, Jan. 2016.
- [75] D. Pan, X. Ruan, C. Bao, W. Li and X. Wang, "Capacitor-Current-Feedback Active Damping With Reduced Computation Delay for Improving Robustness of LCL-Type Grid-Connected Inverter," *IEEE Trans. Power Electron.*, vol. 29, no. 7, pp. 3414-3427, Jul. 2014.
- [76] D. Pan, X. Ruan, C. Bao, W. Li, X. Wang, "Optimized Controller Design for LCL-Type Grid-Connected Inverter to Achieve High Robustness against Grid-Impedance Variation," *IEEE Trans. Ind. Electron.*, vol. 62, no.3, pp.1537-1547, Mar. 2015.
- [77] F. Liu, Y. Zhou, S. Duan, J. Yin, B. Liu, and F. Liu, "Parameter design of a two-current-loop controller used in a grid-connected inverter system with LCL filter," *IEEE Trans. Ind. Electron.*, vol. 56, no. 11, pp. 4483-4491, Nov. 2009.
- [78] D. Yang, X. Ruan and H. Wu, "A Real-Time Computation Method with Dual Sampling Modes to Improve the Current Control Performances of the LCL-Type Grid-Connected Inverter," *IEEE Trans. Ind. Electron.*, vol. 62, no. 7, pp. 4563-4572, Jul. 2015.
- [79] C. Bao, X. Ruan, X. Wang, W. Li, D. Pan, and K. Weng, "Step-by-step controller design for LCL-type grid-connected inverter with capacitor-current-feedback active-damping," *IEEE Trans. Power Electron.*, vol. 29, no. 3, pp. 1239-1253, Mar. 2014.
- [80] X. Li, X. Wu, Y. Geng, X. Yuan, C. Xia, and X. Zhang, "Wide Damping Region for LCL-Type Grid-Connected Inverter with an Improved Capacitor-Current-Feedback Method," *IEEE Trans. Power Electron.*, vol. 30, no. 9, pp. 5247-5259, Sept. 2015.
- [81] J. Kukkola and M. Hinkkanen, "State Observer for Grid-Voltage Sensorless Control of a Inverter Equipped With an LCL Filter: Direct Discrete-Time Design," *IEEE Trans. Ind. Appl.*, vol. 52, no. 4, pp. 3133-3145, July-Aug. 2016.
- [82] J. Dannehl, F. W. Fuchs, S. Hansen, and P. B. Thogersen, "Investigation of active damping approaches for PI-based current control of grid-connected pulse width modulation inverters with LCL filters," *IEEE Trans. Ind. Appl.*, vol. 46, no. 4, pp. 1509-1517, Jul.-Aug. 2010.
- [83] R. P. Alzola, M. Liserre, F. Blaabjerg, R. Sebastian, J. Dannehl, and F. W. Fuchs, "Systematic design of the lead-lag network method for active damping in LCL-filter based three-phase inverters," *IEEE Trans. Ind. Inf.*, vol. 10, no. 1, pp. 43-52, Feb. 2014.
- [84] Z. Xin, P. C. Loh, X. Wang, F. Blaabjerg, and Y. Tang, "Highly Accurate Derivatives for LCL-Filtered Grid Inverter with Capacitor Voltage Active Damping," *IEEE Trans. Power Electron.*, vol. 31, no. 5, pp. 3612-3625, May. 2016.
- [85] H. Komurcugil, N. Altin, S. Ozdemir and I. Sefa, "Lyapunov-Function and Proportional-Resonant-Based Control Strategy for Single-Phase Grid-Connected VSI With LCL Filter," *IEEE Trans. Ind. Electron.*, vol. 63, no. 5, pp. 2838-2849, May 2016.
- [86] M. Huang, X. Wang, P. C. Loh, and F. Blaabjerg, "Active Damping of LCL-Filter Resonance Based on LC-Trap Voltage or Current Feedback," *IEEE Trans. Power. Electron.*, vol. 31, no. 3, pp. 2337-2346, Mar. 2016.
- Hybrid damping**
- [87] Y. Lei, W. Xu, C. Mu, Z. Zhao, H. Li, and Z. Li, "New Hybrid Damping Strategy for Grid-Connected Photovoltaic Inverter With LCL Filter," *IEEE Trans. Appl. Superconduct.*, Vol. 24, no. 5, Oct. 2014.
- [88] N. Mukherjee and D. De, "Analysis and improvement of performance in LCL filter-based PWM rectifier/inverter application using hybrid damping approach," *IET, Power Electron.*, vol. 6, no. 2, pp. 309-325, Feb. 2013.
- Grid-side-damping measures**
- [89] J. He, Y. W. Li, and S. Munir, "A flexible harmonic control approach through voltage controlled DG-grid interfacing inverters," *IEEE Trans. Ind. Electron.*, vol. 59, no. 1, pp. 444-455, Jan. 2012.
- [90] Q.-C. Zhong and G. Weiss, "Synchronverters: Inverters that mimic synchronous generators," *IEEE Trans. Ind. Electron.*, vol. 58, no. 4, pp. 1259-1267, Apr. 2011.
- [91] J. He and Y. W. Li, "Hybrid voltage and current control approach for DG-grid interfacing inverters with LCL filters," *IEEE Trans. Ind. Electron.*, vol. 60, no. 5, pp. 1797-1809, May 2013.
- [92] Y. W. Li and J. He, "Distribution System Harmonic Compensation Methods: An Overview of DG-Interfacing Inverters," *IEEE Trans. Ind. Mag.*, vol. 8, no. 4, pp. 18-31, Dec. 2014.
- [93] H. Akagi, "Control strategy and site selection of a shunt active filter for damping of harmonic propagation in power distribution systems," *IEEE Trans. Power Delivery*, vol. 12, no. 1, pp. 354-363, Jan. 1997.
- [94] H. Akagi, H. Fujita, and K. Wada, "A shunt active filter based on voltage detection for harmonic termination of a radial power distribution line," *IEEE Trans. Ind. Appl.*, vol. 35, no. 3, pp. 638-645, May/Jun. 1999.
- [95] K. Wada, H. Fujita, and H. Akagi, "Considerations of a shunt active filter based on voltage detection for installation on a long distribution feeder," *IEEE Trans. Ind. Appl.*, vol. 38, no. 4, pp. 1123-1130, Jul./Aug. 2002.
- [96] T.-L. Lee, J.-C. Li, and P.-T. Cheng, "Discrete frequency-tuning active filter for power system harmonics," *IEEE Trans. Power Electron.*, vol. 24, no. 5, pp. 1209-1217, Apr. 2009.
- [97] X. Sun, J. Zeng, and Z. Chen, "Site Selection Strategy of Single-Frequency Tuned R-APF for Background Harmonic Voltage Damping in Power Systems," *IEEE Trans. Power Electron.*, vol. 28, no. 1, pp. 135-143, Jan. 2013.
- [98] J. He, Y. W. Li, R. Wang, and C. Zhang, "Analysis and Mitigation of Resonance Propagation in Grid-Connected and Islanding Microgrids," *IEEE Trans. Energy Convers.*, vol. 30, no. 1, pp. 70-81, Feb. 2015.
- [99] X. Wang, F. Blaabjerg, M. Liserre, Z. Chen, J. He, and Y. Li, "An active damper for stabilizing power-electronics-based AC systems," *IEEE Trans. on Power Electron.*, vol. 29, no. 7, pp: 3318-3329, Feb. 2014.
- [100] X. Wang, Y. Pang, P.C. Loh, F. Blaabjerg, "A Series-LC-Filtered Active Damper with Grid Disturbance Rejection for AC Power-Electronics-Based Power Systems," *IEEE Trans. Power Electron.*, vol.30, no.8, pp. 4037-4041, Aug. 2015.
- [101] X. She, A. Huang, and R. Burgos, "Review of solid-state transformer technologies and their application in power distribution systems," *IEEE J. Emerging Sel. Topics Power Electron.*, vol. 1, no. 3, pp. 186-198, Sep. 2013.
- [102] X. She, A. Q. Huang, F. Wang, and R. Burgos, "Wind energy system with integrated active power transfer, reactive power compensation, and voltage conversion functions," *IEEE Trans. Ind. Electron.*, vol. 60, no. 10, pp. 4512-4524, Oct. 2013.
- [103] S. Xu and A. Huang, "Solid State Transformer in the Future Smart Electrical System," in *Proc. IEEE PES*, Vancouver, BC, Canada, Jul. 21-25, 2013, pp. 1-5.
- [104] D. G. Shah and M.L. Crow, "Stability Design Criteria for Distribution Systems With Solid-State Transformers," *IEEE Trans. Power Deliv.*, vol. 29, no. 6, pp. 2588-2595, Dec. 2014.
- [105] G. De Carne, M. Liserre, K. Christakou, and M. Paolone, "Integrated voltage control and line congestion management in Active Distribution Networks by means of smart transformers," in *Proc. IEEE ISIE*, Istanbul, Turkey, Jun. 1-4, 2014, pp. 2613-2619.
- [106] C. Kumar and M. Liserre, "Operation and Control of Smart Transformer for Improving Performance of Medium Voltage Power Distribution System," in *Proc. IEEE PEDG*, Aachen German, Jun. 22-25, 2015, pp. 1-6.
- [107] G. De Carne, G. Buticchi, M. Liserre, Yoon Changwoo and F. Blaabjerg, "Voltage and current balancing in Low and Medium Voltage grid by means of Smart Transformer," in *Proc. IEEE PESG*, Denver, CO, America, Jul. 36-30, 2015, pp. 1-5.
- [108] Hirofumi Akagi, Edson Hirokazu Watanabe, Mauricio Aredes, "Hybrid and Series Active Filters," in *Instantaneous Power Theory and Applications to Power Conditioning*, 1, Wiley-IEEE Press, 2007, pp.221-263.
- [109] A. E. Leon, M. F. Farias, P. E. Battaiotto, J. A. Solsona, M. I. Valla, "Control Strategy of a DVR to Improve Stability in Wind Farms Using Squirrel-Cage Induction Generators," *IEEE Trans. Power Systems*, vol.26, no. 3, pp.1609 - 1617, Aug.2011.
- [110] S. Srianthumrong, H. Fujita, H. Akagi, "Stability analysis of a series active filter integrated with a double-series diode rectifier", *IEEE Trans. Power. Electron.*, vol. 17, no. 1, pp. 117-124, Jan.2002.
- Delay reduction**
- [111] L. Corradini, W. Stefanutti, and P. Mattavelli, "Analysis of multi-sampled current control for active filters," *IEEE Trans. Ind. Appl.*, vol. 44, no. 6, pp. 1785-1794, Nov. 2008.
- [112] D. G. Holmes, T. A. Lipo, B. P. McGrath, and W. Y. Kong, "Optimized design of stationary frame three phase AC current regulators," *IEEE Trans. Power Electron.*, vol. 24, no. 11, pp. 2417-2426, Nov. 2009.
- [113] C. Chen, J. Xiong, Z. Wan, J. Lei and Kai Zhang, "A Time Delay Compensation Method Based on Area Equivalence For Active Damping of an LCL-Type Inverter," *IEEE Trans. Power Electron.*, vol. 32, no. 1, pp. 762-772, Jan. 2017.

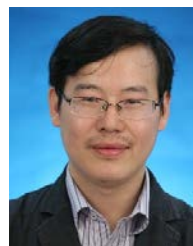

Weimin Wu received Ph.D. degrees from the College of Electrical Engineering, Zhejiang University, Hangzhou, China, in 2005.

He worked as a research engineer in the Delta Power Electronic Center (DPEC), Shanghai, from July, 2005 to June, 2006. Since July, 2006, he has been a Faculty Member at Shanghai Maritime University, where he is currently a Full Professor in Department of Electrical Engineering. He was a Visiting Professor in the Center for Power Electronics Systems (CPES), Virginia Polytechnic Institute and State University, Blacksburg, USA, from Sept. 2008 to March. 2009. From Nov. 2011 to Jan. 2014, he is also a

visiting professor in the Department of Energy Technology, Aalborg University, Denmark, working at the Center of Reliable Power Electronics (CORPE). He has coauthored over 60 papers and holds five patents. His areas of interests include power converters for renewable energy systems, power quality, smart grid, and energy storage technology.

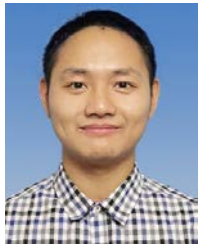

Yuan Liu was born in Jiangsu, China, in 1990. He received the B.S. degree in electrical engineering and automation from Nanjing University of Science and Technology, Nanjing, China, in 2013 and the M.S. degree in power electronics and power drives in the Research Institute of Electronic Automation, Shanghai Maritime University, Shanghai, China.

He was a Research Assistant with the Centre for Smart Energy Conversion and Utilization Research, Department of Electronic Engineering, College of Science and

Engineering, City University of Hong Kong, Kowloon, Hong Kong in 2016. He is currently an electric engineer with Marine Design & Research Institute of China, Shanghai. His current research interests include digital control techniques of power converters, renewable energy generation systems and green ship.



Yuanbin He (S '14) received the B.Eng. and M.Eng. degrees both in electrical engineering from the Shanghai Maritime University, Shanghai, China, in 2009 and 2011, respectively, and the Ph.D. degree in electronic engineering from the City University of Hong Kong, Kowloon, Hong Kong, in 2017. Currently, he is with the City University of Hong Kong as a postdoctoral research fellow with the Centre for Smart Energy Conversion and Utilization Research, City University of Hong Kong, Kowloon, Hong Kong.

From July 2011 to March 2013, he was with Nanjing FSP-Powerland Technology Inc., as an associate researcher. Thereafter, he was a research assistant with the Centre for Smart Energy Conversion and Utilization Research in the City University of Hong Kong until August 2013. From February to June 2016, he was a visiting scholar at the Department of Electrical and Computer Engineering, University of Manitoba, Canada.

His current research interests include control of power converters and renewable energy application.



Henry Shu-hung Chung ('95 M, '03SM, '16F) received his B.Eng. degree in 1991 and PhD degree in 1994 in electrical engineering, both from The Hong Kong Polytechnic University.

Since 1995 he has been with the City University of Hong Kong (CityU). He is currently professor of the Department of Electronic Engineering, and Director of Centre for Smart Energy Conversion and Utilization Research. His research interests include time- and frequency-domain analysis of power electronic circuits, switched-capacitor-based

converters, random-switching techniques, control methods, digital audio amplifiers, soft-switching converters, and electronic ballast design. He has edited one book, and authored eight research book chapters, and over 390 technical papers including 180 refereed journal papers in his research areas, and holds 40 patents. Dr. Chung is currently Editor-in-chief of the IEEE Power Electronics Letters, and Associate Editor of the IEEE Transactions on Power Electronics, and IEEE Journal of Emerging and Selected Topics in Power Electronics.



Marco Liserre (S'00-M'02-SM'07-F'13) received the MSc and PhD degree in Electrical Engineering from the Bari Polytechnic, respectively in 1998 and 2002. He has been Associate Professor at Bari Polytechnic and Professor in reliable power electronics at Aalborg University (Denmark). He is currently Full Professor and he holds the Chair of Power Electronics at Christian-Albrechts-University of Kiel (Germany). He has published over 300 technical papers (more than 86 of them in international peer-reviewed journals) and a

book. These works have received more than 20000 citations. Marco Liserre is listed in ISI Thomson report "The world's most influential scientific minds" from 2014.

He is member of IAS, PELS, PES and IES. He has been serving all these societies in different capacities and he has received several awards.



Frede Blaabjerg (S'86-M'88-SM'97-F'03) was with ABB-Scandia, Randers, Denmark, from 1987 to 1988. From 1988 to 1992, he was a Ph.D. Student with Aalborg University, Aalborg, Denmark. He became an Assistant Professor in 1992, an Associate Professor in 1996, and a Full Professor of power electronics and drives in 1998. From 2017 he became a Villum Investigator.

His current research interests include power electronics and its applications such as in wind turbines, PV systems, reliability, harmonics and adjustable speed drives. He has published more than 450 journal papers in the fields of power electronics and its applications. He is the co-author of two monographs and editor of 6 books in power electronics and its applications. He was the Editor-in-Chief of the IEEE TRANSACTIONS ON POWER ELECTRONICS from 2006 to 2012.