



TAMPEREEN TEKNILLINEN YLIOPISTO
TAMPERE UNIVERSITY OF TECHNOLOGY

Johanna Ruoranen

**Effects of Static Loading and Environmental Conditions
on the Aging Behavior of Aluminum Adhesive Joints**



Julkaisu 1576 • Publication 1576

Tampere 2018

Tampereen teknillinen yliopisto. Julkaisu 1576
Tampere University of Technology. Publication 1576

Johanna Ruoranen

Effects of Static Loading and Environmental Conditions on the Aging Behavior of Aluminum Adhesive Joints

Thesis for the degree of Doctor of Science in Technology to be presented with due permission for public examination and criticism in Konetalo Building, Auditorium K1702, at Tampere University of Technology, on the 19th of October 2018, at 12 noon.

Tampereen teknillinen yliopisto - Tampere University of Technology
Tampere 2018

Doctoral candidate: Johanna Ruoranen
Laboratory of Materials Science
Faculty of Engineering Sciences
Tampere University of Technology
Finland

Supervisor: Professor Veli-Tapani Kuokkala
Laboratory of Materials Science
Faculty of Engineering Sciences
Tampere University of Technology
Finland

Instructor: Professor Emeritus Tuomo Tiainen
Laboratory of Materials Science
Faculty of Engineering Sciences
Tampere University of Technology
Finland

Pre-examiners: Professor Emeritus Veli Kujanpää
VTT Technical Research Centre of Finland Ltd.
Finland

Dr. Pirjo Laurila
AGCO Power Inc.
Finland

Opponents: Professor Emeritus Veli Kujanpää
VTT Technical Research Centre of Finland Ltd.
Finland

Dr. Mikko Viljanmaa
KIILTO Oy
Finland

ABSTRACT

During service, adhesive joints will be exposed to different aging environments, which tends to decrease the durability and the strength of the joint. Humidity and temperature are the most dominant environmental factors causing weakening of the joints. In the presence of static or dynamic loading, the weakening may be accelerated and cause an unexpected failure. Many studies have been carried out to determine the influence of the environmental factors (mainly temperature and humidity) or mechanical loading (cyclic or static) on the durability of the adhesive joints. Theoretical predictions concerning the combined effects of the environmental factors and mechanical loading on the aging behavior of the adhesive joints can be found in the literature, but there are no extensive experimental studies on this subject. Greater understanding of these combined effects is needed, and research work in this area gives better tools for predicting the durability of adhesive joints under different aging conditions.

This thesis studies the combined effects of static loading and environmental aging (temperature and humidity) on the strength and durability of aluminum adhesive joints. The strength behavior and durability of the studied joints aged in different aging environments with different static loading levels are determined. The influence of different pretreatment methods on the strength and durability of the studied joints is also determined. The fracture surfaces of the joints are studied to reveal the fracture type.

This study verifies the existence of a threshold stress for all specimens and all studied aging combinations. If the loading stress exceeds this threshold stress value, the joint strength drops quite rapidly to zero. The knowledge of the existence of such threshold stress is extremely important when designing the adhesively joined structures for conditions leading to aging. The threshold stress level is quite low, depending on the aging conditions and the joint pretreatment method. Typical threshold stress values measured in this study are 5% to 10% of the original unaged strength of the joint. Under milder aging conditions and with efficient pretreatment methods, the threshold stress value can be 10% to 15% of the original joint strength. For more severe aging conditions and less efficient pretreatment methods, the threshold stress level can be from 0% to 5% of the unaged joint strength.

Silane pretreatment of the adherend surfaces before joining enhances the durability of the joints. It also increases the threshold stress level when compared to specimens pretreated only by sand blasting and degreasing. The initiation of the rapid strength decrease and failure of the joint when loaded above the threshold stress level are moved towards longer times with the silane pretreatment of the specimens. Silane pretreatment enhances the joint durability especially in high humidity and high temperature environments.

PREFACE

This work was carried out at the Laboratory of Materials Science (formerly Department of Materials Science) of Tampere University of Technology during the years 2007-2018. The background and preliminary work leading to the initiation of this thesis was carried out in several projects funded by the Finnish Funding Agency for Technology (TEKES) and participating companies. This work was carried out during my appointment as a University Teacher at Tampere University of Technology.

My work was supervised by Professor Emeritus Tuomo Tiainen and Professor Veli-Tapani Kuokkala, to whom I wish to express my gratitude for their support and guidance during this whole project. To Professor Tuomo Tiainen I want to express my deep gratitude for his continuous encouragement, patience, and deep knowledge of joining techniques. I give my special thanks to Senior Laboratory Technician Kati Mökkönen for her help with the specimen preparation, test adjustment, and tensile testing. I want to express my gratitude also to Laboratory Technician Markku Pohjola for his help with aging tests and for Dr. Tuomo Nyysönen for his help with specimen preparation. I am also grateful to our two laboratory technicians, Mr. Terho Kaasalainen and Mr. Ari Varttila, for building the test rigs. I am grateful to M.Sc. Taneli Lahtinen for his help and advices in the work with the aging cabinet as well as to Dr. Antti Hynnä for arranging the time for aging tests in the aging cabinets. I would also like to thank many of my colleagues at the Laboratory of Materials Science for the fruitful discussions and peer support during the doctoral thesis process. I also wish to express thanks to M.Sc. Taru Karhula and Lic.Tech. Kati Valtonen for our discussions and their encouragement.

Last but not least, I want to express my gratitude to my family Timo, Julia, Anni and Joonas for their patience and support during the thesis work. I also want to thank my parents and my friends for their support and encouragement.

Tampere, 26.8.2018

Johanna Ruoranen

AUTHOR`S CONTRIBUTION

Johanna Ruoranen was the main researcher in this work, who planned and organized all the experiments. She performed the aging studies, analyzed the test results, and wrote this thesis. Specimen preparation and loading of the samples were performed together with Senior Laboratory Technician Kati Mökkönen, who also performed the tensile tests of the joints. The supervisors, Professor Emeritus Tuomo Tiainen and Professor Veli-Tapani Kuokkala, commented and suggested corrections and additions to the manuscript.

LIST OF SYMBOLS AND ABBREVIATIONS

Greek symbols

γ_A	Surface energy of the adhesive
γ_{AS}	Surface energy of the adhesive-substrate interface
γ_{AW}	Surface energy of the adhesive-water interface
γ_{Lv}	Surface energy of the liquid-vapor interface
γ_S	Surface energy of the substrate
γ_{SL}	Surface energy of the solid-liquid interface
γ_{SV}	Surface energy of the solid-vapor interface
γ_{SW}	Surface energy of the substrate-water interface
π_E	Spreading coefficient
τ	Shear strength
τ_0	Initial shear strength
τ_f	Final strength
τ_{res}	Residual strength

Latin symbols

D	Diffusion coefficient
E_D	Activation energy of diffusion
F	Load
F_x	Diffusion flux in direction x
M_e	Mass absorbed at equilibrium
M_t	Mass absorbed at time t
R	Universal gas constant

T	Temperature
T _g	Glass transition temperature
t	Time
W _A	Work of adhesion

Abbreviations

Al	Aluminum
Al 6082-T6	T6 tempered magnesium and silicon alloyed aluminum alloy
Al ₂ O ₃	Aluminum oxide
AlOOH	Aluminumoxyhydroxide (boehmite)
Araldite 2014	Two-component epoxy adhesive
ASTM	American Society for Testing and Materials
BF ₃	Boron trifluoride
BSAA	Boric sulfuric acid anodizing
C	Carbon
CAA	Chromic acid anodizing
CAE	Chromic acid etching
CF ₄	Tetrafluoromethane
CF ₃ H	Carbontrifluoride (methyl trifluoride)
C ₆ H ₅ CH ₂ NH ₂	Benzylamine
Cl	Chlorine
CLP	Ciba laser pretreatment
-CN	Cyano group
CO ₂	Carbon dioxide
CTBAC	Carboxyl-terminated butadiene acrylonitrile copolymer
DGEBA	Diglycidyl ether of bisphenol A

DGEBF	Diglycidyl ether of bisphenol F
DMTA	Dynamic Mechanical Thermal Analysis
FPL	Sulfuric acid-dichromate etching (Forest Product Laboratory)
FTIR	Fourier-transform infrared spectroscopy
γ - GPS	γ – glycidoxypropyltrimethoxysilane
GRP	Glass-reinforced plastic
H	Hydrogen
H ₂ O	Water
MDI	Methylene di-isocyanate
MWCNT	Multi Wall Carbon Nanotube
Na	Sodium
NaOH	Sodium hydroxide
Nd-YAG	Neodymium – doped yttrium aluminum garnet
NH ₃	Ammonia
OH	Hydroxide
PAA	Phosphoric acid anodizing
pH	Potential of hydrogen
PH ₃	Phosphane
PLA	Pulsed laser ablation
PUR	Polyurethane
RF	Radio frequency
RGO	Reduced graphene oxide
RH	Relative humidity
RT	Room temperature
SAA	Sulfuric acid anodizing
SEM	Scanning electron microscope/microscopy
Si	Silicon

SiO ₂	Silicon dioxide
Si(OH) ₃	Trisilanol
TDI	Toluene di-isocyanate
TUT	Tampere University of Technology
UV	Ultraviolet
XPS	X-ray photoelectron spectroscopy

CONTENTS

ABSTRACT	i
PREFACE	iii
AUTHOR`S CONTRIBUTION	v
LIST OF SYMBOLS AND ABBREVIATIONS	vii
CONTENTS	xi
1. INTRODUCTION	1
2. ADHESIVE JOINTS IN METALS: FORMATION AND STRUCTURE	3
2.1 General description of adhesive joint formation	3
2.2 Theories of adhesion	4
2.2.1 Mechanical interlocking theory	4
2.2.2 Physical adsorption theory	5
2.2.3 Chemical bonding theory	8
2.2.4 Diffusion theory	9
2.2.5 Electrostatic theory	9
2.2.6 Theory of weak boundary layer	10
2.3 Structure of adhesive joint	10
3. GENERAL CHARACTERISTICS OF ADHESIVE JOINTS IN METALS	13
3.1 Strength properties	13
3.2 Adhesive types	17
3.2.1 Polyurethanes	17
3.2.2 Acrylic adhesives	18
3.2.3 Anaerobic adhesives	19
3.2.4 Cyanoacrylates	19
3.2.5 Epoxies	20
3.3 Aging characteristics	22
4. AGING OF ADHESIVE JOINTS	23
4.1 Manifestation of aging	23
4.2 Factors affecting the aging behavior	24
4.2.1 Humidity and water diffusion	25
4.2.2 Temperature	33
4.2.3 Stresses	34
5. METHODS FOR IMPROVING THE ADHESION AND AGING BEHAVIOR	37
5.1 Surface pretreatments	37
5.1.1 Degreasing methods	38
5.1.2 Abrading methods	39
5.1.3 Chemical pretreatments	41
5.2 Joint protection	52

6. AIM OF THE WORK	53
7. EXPERIMENTAL METHODS	55
7.1 Studied materials and adhesives	55
7.2 Preparation of test specimens	56
7.3 Aging exposures	57
7.4 Testing of aged joints	59
7.5 Characterization of tested joints	59
8. RESULTS	61
8.1 Development of strength as a function of aging time	61
8.2 Evolution of fracture characteristics during aging	64
9. ANALYSIS AND DISCUSSION OF THE RESULTS	71
9.1 Effects of temperature and humidity on aging	71
9.2 Influence of surface pretreatment on aging	78
9.3 Effect of static loading on aging	81
9.3.1 Apparent threshold stress for accelerated aging	82
9.3.2 Factors affecting the threshold stress value	87
9.4 Influence of joint protection on aging	88
9.5 Reliability of the results	89
10. CONCLUDING REMARKS	93
10.1 Main scientific contributions of the study	93
10.2 Detailed conclusions	93
10.3 Research questions revisited	95
11. SUGGESTIONS FOR FURTHER RESEARCH	97
12. REFERENCES	99

1. INTRODUCTION

Adhesive joining is nowadays a significant joining method, as it has several advantages when compared to traditional joining techniques. They include, e.g., the possibility of joining dissimilar materials, joining thin materials to thick ones, and the absence of deformations and distortions in the joined thin materials. Due to these advantages, also the adhesive joining of metals has increased strongly during the past decades.

Besides the several advantages of adhesive joining, there is one significant drawback in its use: adhesive joints tend to suffer from aging in their working environment. The aging is mostly manifesting itself as a decrease of the joint strength with increasing exposure time. During service, environmental factors such as temperature and humidity can affect the durability of the adhesive joint. Together with eventual internal or external loading stresses, these environmental factors tend to accelerate the aging process, consequently leading to the loss of strength and decrease of the durability of the joint.

A lot of research has been carried out to reveal the effects of environmental factors such as humidity and temperature on the durability of adhesive joints. Research results exist also on the effects of stresses on the properties and durability of adhesive joints. Theoretical predictions of the combined influence of loading and environmental factors on the aging rate of adhesive joints can also be found in the literature. There are, however, no extensive experimental studies on the combined effects of environmental factors and loading on the aging, durability and strength of adhesive metal joints. This knowledge would be of extreme importance for the practical use of adhesive metal joints in different working environments.

The research questions of this thesis can be formulated as follows:

What are the combined effects of static loading and simultaneous environmental aging caused by elevated temperature and humidity on the durability of adhesive metal joints?

How do the joint pretreatment methods influence the strength and durability of adhesive metal joints exposed to different temperature and humidity conditions with and without static loading?

This study is an extensive exploration of the combined effects of static loading and environmental aging factors, humidity and temperature, on the durability and strength of adhesive metal joints. In this work, the influence of selected adherend surface pretreatment methods on the aging behavior and strength of the joints is studied under combined aging and loading conditions. The development of an effective, safe, and economical pretreatment method resulting in high bond strength and long term

durability for adhesively bonded structures is one of the key questions in the current adhesive bonding research.

In this study, aluminum is used as the adherend material. Aluminum as a lightweight and corrosion resistant material is one of the most widely used metallic adherends in structural adhesive bonding. Its significance as a metallic adherend material can be predicted to increase due to the tendency towards more and more lightweight and effective structures. An epoxy-based adhesive was selected for this study due to its high strength properties and its ability to withstand both high temperature and high humidity conditions. Epoxy adhesives are also widely used for metallic joints in several areas of technology. Silane pretreatment has been found to be an effective and environmentally friendly method for the pretreatment of metallic adherends, including aluminum. Therefore, it was used also in this study as a pretreatment of the adherend surfaces in addition to the more commonly used sandblasting and degreasing treatments.

The answers to the research questions, as well as the main scientific contributions of this work, will be presented in Chapter 10, *Concluding remarks*.

2. ADHESIVE JOINTS IN METALS: FORMATION AND STRUCTURE

Adhesive joints are nowadays widely used in several areas of technology. In the past few decades, the development of materials technology and the increased understanding of adhesion mechanisms have strengthened the position of adhesive joining as a complementary method for traditional joining methods, such as welding and mechanical joining. There are several advantages in using adhesive joining of metals as compared with traditional joining methods, including, e.g., the possibility for lightweight, multimaterial, and cheaper structures. Adhesive joining also makes it possible to obtain high joint strength between similar or dissimilar materials.

There are several types of (metal) adherends and adhesives available for adhesive joining, and there are also several theories to explain the formation and structure of adhesive joints. All of these theories typically explain adhesion in some specific cases and under some specific circumstances, but none of them can explain all the factors and processes influencing the adhesion.

2.1 General description of adhesive joint formation

An adhesive is a polymeric material that adheres and polymerizes (hardens) when applied to the surfaces of the substrates and joins them permanently together. This process is called adhesive bonding, where the adhesive joins the bonded surfaces together and resists their separation. The forces joining the surfaces together may arise from van der Waals forces, chemical bonding, or electrostatic attraction. There are several theories to explain the adhesion mechanisms. In practice, the joint formation is most probably a combination of several mechanisms [1-2].

The adhesive must flow well and wet the surfaces to form a reliable and strong adhesive bond. The wettability defines how easily a liquid spreads on a solid surface. Adhesive wetting is based on the thermodynamic work of adhesion, which is derived from the first law of thermodynamics. The work of adhesion is defined as the work required to separate a unit area of two phases in contact. The work of adhesion, W_A , can be calculated by the following formula, if these phases are separated in dry air:

$$W_A = \gamma_A + \gamma_S - \gamma_{AS} \quad (1)$$

In Equation (1), γ_A is the surface energy of the adhesive, γ_S is the surface energy of the substrate, and γ_{AS} is the surface energy of the adhesive-substrate interface.

In the presence of water, Equation (1) is given in the form:

$$W_{A,W} = \gamma_{AW} + \gamma_{SW} - \gamma_{AS} \quad (2)$$

where γ_{AW} is the surface energy of the adhesive-water interface, and γ_{SW} is the surface energy of the substrate-water interface [3].

The wettability depends on the surface energy and surface tension properties of the materials, and it is best described by the resulting contact angle. The properties of adhesives, such as the viscosity and pot life, are also influencing its wettability. To build the required strength for the joint, strong adhesion of the adhesive to both surfaces as well as strong cohesion within the adhesive are needed. The adhesive should have a lower surface energy than the surfaces to be joined to obtain good wettability [3-5].

2.2. Theories of adhesion

There is no general theory explaining all the adhesion phenomena. Actually, there are several theories describing the mechanisms of adhesion. One of the main difficulties in the study of adhesion mechanisms is that the phenomenon is located in the boundary region of several intersecting scientific fields including surface chemistry, rheology, polymer physics and polymer chemistry, materials science, and mechanics of materials.

There are six main theories explaining the adhesion mechanisms: a) mechanical interlocking theory, b) physical adsorption theory, c) chemical bonding theory, d) diffusion theory, e) electrostatic theory, and f) weak boundary layer theory. Adhesive bonding is most probably a result of some kind of a combination of these different proposed adhesion mechanisms [1-2, 4-8].

The understanding of the adhesion mechanisms has increased remarkably during the last few decades, creating possibilities for the industry to use adhesives extensively in new areas of technology. Understanding the theories helps to clarify why an adhesive joint is working in some cases and not in some other cases.

2.2.1. Mechanical interlocking theory

The mechanical interlocking model is one of the oldest adhesion theories. According to the mechanical interlocking theory, the main source of adhesion is the penetration of the adhesive into the irregularities of the adherend surfaces. The adhesive penetrates and fills the cavities, pores, and asperities of the solid surface and then hardens. Mechanical interlocking may be increased by roughening the surfaces before

bonding. Despite the roughness, irregularities, and porosity of the substrates, the mechanical interlocking requires good wetting of the substrate by the adhesive. Care must be taken to ensure that the adhesive spreads well over the roughened surface. Figure 1 shows different kinds of wetting behavior [2, 6, 7].

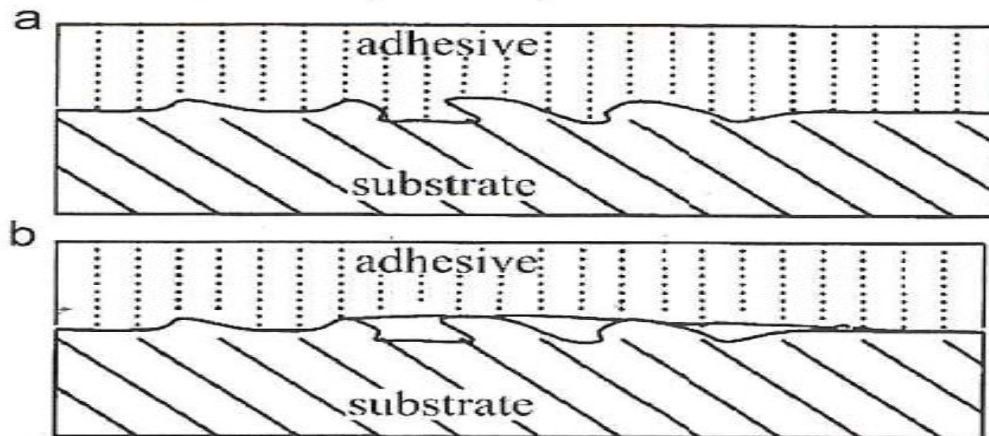

Figure 1. a) Good wetting and b) poor wetting [2]

Mechanical roughening of the surfaces will enhance the adhesion due to the increased mechanical interlocking, but also due to the formation of highly reactive and clean surfaces and increasing of the actual contact surface area. The strength of the joint usually increases when the surfaces are mechanically roughened. However, this theory is not universally valid because good adhesion has been obtained also between very smooth surfaces. There are also some contradicting results, which show that increasing roughness may also lower the joint strength [2, 6].

2.2.2 Physical adsorption theory

The physical adsorption theory is the main theory explaining the adhesion phenomena. According to this theory, adhesion is a result of a molecular contact between the adhesive and the substrate and the weak attractive forces that develop between them. These forces are weak forces across the interfaces between the atoms and the molecules, when they are close together. The most common intermolecular forces that are influencing adhesion are the van der Waals forces and the Lewis-type acid-base interactions. The magnitude of these intermolecular forces depends on the thermodynamic quantities such as surface free energies, and consequently this theory is also known as the “thermodynamic theory” [1-2].

The molecular contact between the adhesive and the substrate requires good wetting properties, i.e., good wetting ability of the adhesive and spreading of the adhesive over the adherend surface. To wet a solid surface well, the adhesive should have a lower surface tension than the critical surface tension of the solid. The wetting ability in a solid-liquid system can be studied by contact angle measurements. During these measurements, a drop of the studied liquid is set on a planar solid surface and the contact angle θ (Fig. 2) is measured. According to the Young's equation [3, 9]:

$$\gamma_{SV} = \gamma_{SL} + \gamma_{LV} \cos \theta \quad (3)$$

where γ is the surface tension (energy). The subscript SV refers to the solid-vapor interface, SL means the solid-liquid interface, and LV refers to the liquid-vapor interface. Harkins and Livingston [9] took also into account the fact that clean surfaces tend to adsorb vapors, oils, etc. The surface energy for the surfaces containing adsorbed vapor is less than the surface energy for a "clean" surface, and therefore Harkins and Livingston made a correction to the Young's equation:

$$\gamma_{SV} = \gamma_{SA} - \pi_E \quad (4)$$

$$\gamma_{LV} \cos \theta = \gamma_{SA} - \pi_E - \gamma_{SL} \quad (5)$$

$$\gamma_{SA} = \gamma_{LV} \cos \theta + \gamma_{SL} + \pi_E \quad (6)$$

The subscript SA refers to the adsorbed vapor layer and π_E is the spreading coefficient (pressure). The spreading coefficient π_E can be defined by the formula:

$$\pi_E = \gamma_S - \gamma_{SV} \quad (7)$$

The quantity γ_S is the surface free energy of the solid in vacuum. When $\theta > 10^\circ$, the spreading coefficient is in many cases low and can be neglected. Then γ_S can be used instead of γ_{SV} [3, 9].

When the contact angle θ increases, the liquid does not spread well over the solid surface. At the contact angle values $\theta > 90^\circ$, wetting is poor. When the contact angle decreases below 90° , the liquid spreads better over the solid surface and when $\theta = 0^\circ$, the liquid totally wets the solid and spontaneously spreads over the surface. For spontaneous wetting:

$$\gamma_S \geq \gamma_{SL} + \gamma_{LV} \quad (8)$$

Good wetting requires that the adhesive has a lower surface tension than the adherends. This partly explains why organic adhesives generally have good adhesion

to metals but their adhesion to untreated polymeric surfaces is weak. Figure 2 shows how the contact angle describes the wettability.

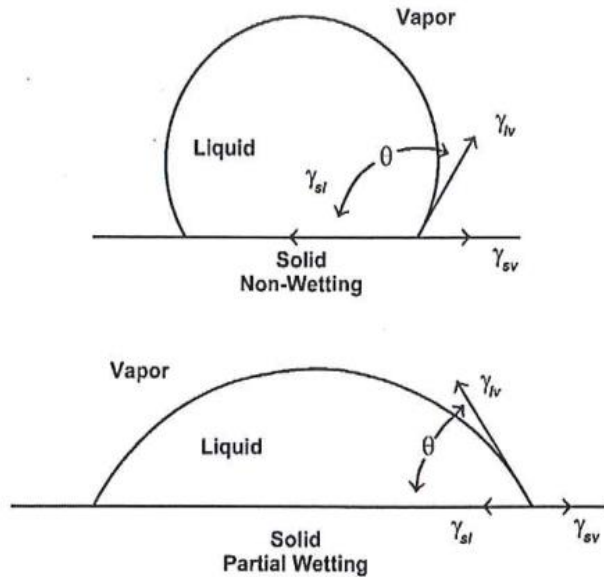

Figure 2. Interdependence of the wettability of adhesives and the contact angle [5].

According to the acid-base theory, adhesion is a result of the polar attractions of Lewis acids and bases at the interface. According to this Lewis acid-base theory, an acid is an electron acceptor and a base is an electron donor. Every cation can be an acid and react with chemical compounds such as boron trifluoride, BF_3 , and silicon di-oxide, SiO_2 . Anions and compounds such as ammonia, NH_3 , phosphane, PH_3 , and benzylamine, $\text{C}_6\text{H}_5\text{CH}_2\text{NH}_2$, are bases. Hydrogen bonding is a special case of the acid-base interactions. Water molecules have both acidic and basic characteristics. Hydrogen bonding is one of the most remarkable cases of the secondary molecular interactions. It is stronger than the dipole-dipole or van der Waals interactions but weaker than chemical (ionic or covalent) bonds. In some cases, the hydrogen bonding is classified to the chemical bonding categories due to its covalent nature, but it is much weaker than chemical bonds. Figure 3 shows the bond energies of different bonds [3, 7].

Type	Example	<i>E</i> (kJ/mol)
Covalent	C–C	350
Ion–ion	Na ⁺ ... Cl ⁻	450
Ion–dipole	Na ⁺ ... CF ₃ H	33
Dipole–dipole	CF ₃ H ... CF ₃ H	2
London dispersion	CF ₄ ... CF ₄	2
Hydrogen bonding	H ₂ O ... H ₂ O	24

Figure 3. Examples of the bond energies of Lifshitz-van der Waals interactions and chemical bonds [7].

2.2.3. Chemical bonding theory

The chemical bonding theory is based on the strong primary covalent and ionic bonding forces. Covalent and ionic bonds are much stronger than the secondary bonding forces such as van der Waals interactions, and the adhesive joints based on chemical bonding are very strong. The formation of chemical bonds between the adhesive and the adherend is dependent on the nature and mutual reactivity of both species. A chemical bond is formed between the chemical groups of the adherend surface and the adhesive. These chemical bonds are seldom formed without any modification of the adherend surface, and therefore different kinds of chemical pretreatments are used to modify and activate the adherend surface. Nowadays there is a tendency of using so-called coupling agents to promote the chemical adhesion and to improve the joint strength between the adhesive and the adherend. Coupling agents are molecules that are able to react chemically at both ends; one end is reacting with the adherend (substrate) and the other end with the polymeric adhesive. The most common coupling agents that are used to promote adhesion are silane molecules. According to the chemical bonding theory, the coupling properties of silanes are based on their unique hybrid chemical structure. Silane molecules are bifunctional, containing inorganic polar silanol groups that react chemically with the inorganic surface (metals, etc.) and organofunctional groups that react with the organic base polymer in the adhesive. Silanes promote adhesion and form strong covalent bonds across the interface. Silanes enhance the environmental durability of the joints and improve the adhesion especially in humid conditions. The use of silanes increases the density of strong bonds between the adhesive and the (oxide) layers of adherends, and at the same time they also increase the hydrolytic stability [1-2, 6, 7, 9].

The chemical bonding strongly increases the adhesion between the adhesive and the adherends. However, these bonds alone are often not sufficient to guarantee good

adhesion at the interfaces when defects, cracks, or air bubbles are present. Typically, also other adhesion mechanisms exist simultaneously to form the joint between the adherends (as discussed earlier in this chapter).

2.2.4 Diffusion theory

According to the diffusion theory, adhesion is a result of interdiffusion of the molecules at the interface between the adhesive and the adherend. The adhesive and adherend molecules penetrate between each other and interlock. This theory is primarily valid when both the adhesive and the adherends are polymers. Both the adhesive and the adherend must have long-chain molecules, macromolecular chains, which are sufficiently mobile and sufficiently mutually soluble. They must be in contact above their glass transition temperature T_g . The interdiffusion process and the consequent adhesive strength are dependent on several factors, such as the nature and chain length of the macromolecules, their concentration, and temperature. Interdiffusion is optimal when the solubilities of both polymers to each other are equal [1-2, 6-7].

2.2.5. Electrostatic theory

This theory is also known as the electrical double layer theory, parallel plate capacitor theory, or electronic theory. This theory is based on phenomena where electrons are transferred from the adhesive to the adherend due to their different kind of electronic band structure. Attraction forces will form between the two surfaces, when one of them carries a net positive charge and the other one a net negative charge as, for example, in the acid-base interactions and in the ionic bonding. Electrons will be mutually shared, and the electrical double layer will form at the adhesive and adherend interface (Fig. 4). The adhesive-adherend junction can be seen as a parallel plate capacitor. This theory is valid for incompatible materials, such as polymer and metallic adherends. These donor-acceptor relationships have been noticed only at interfaces, not in bulk materials. The strength of the joint depends on the charge density. This theory explains the electrical discharges, which may be noticed when an adhesive is peeled off from an adherend surface. The significance of this theory in explaining the strength of the adhesive joint is lower as compared to, for example, chemical and physical adsorption theories [1-2, 4, 6, 7, 10].

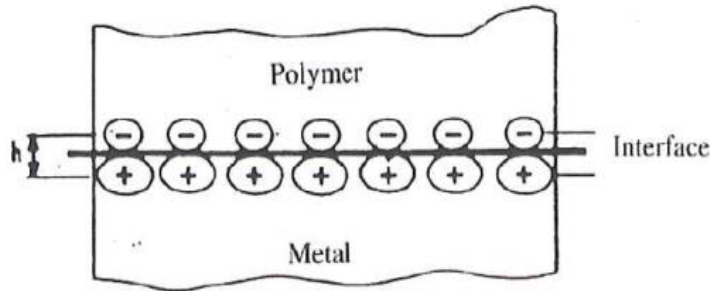

Figure 4. Electrical double layer at a polymer-metal interface [2].

2.2.6 Theory of weak boundary layer

This theory is based on the idea that the cohesive strength of the weak boundary layer can be always considered as the main factor affecting the strength of adhesion even when the failure seems to be interfacial. According to this theory, the cohesive failure in the weaker material near the interface is more probable than the failure along the adhesive-adherend interface. The failure of the adhesive joint is due to the weak boundary layer, which is formed. These weak boundary layers, affecting the durability and strength of the adhesive joint, can be weak oxide layers, inclusions of air, dust, oil, and other impurities on the surfaces. To achieve a strong adhesive joint, these weak boundary layers should be removed before the adhesive joining process. The weak boundary layers can be removed with different surface pretreatments. A weak boundary layer will easily form at the interface, if the adhesive does not wet the adherend well. As a result, the joint durability and strength will be lower. Good wetting of the substrate by the adhesive can also be obtained by using different pretreatments [1, 2, 7].

2.3 Structure of adhesive joints

In the adhesive joining process, the adherend surfaces are joined together with a joining agent, i.e., the adhesive. Pure metal adherend surfaces normally have high surface free energies, and they are easily wetted by polymer-based liquid adhesives. The strength and durability properties of this type of adhesive joints are normally very good. In most cases, the outermost surface of the metal consists of weaker layers, which tend to lower the durability and strength of the adhesive joint, as presented in Chapter 2.2.6. Figure 5 shows absorbed layers on a metal surface, and a strong adhesive joint will form only when these interfacial layers are strong enough to withstand external stresses. In many applications, good aging resistance against environmental factors such as high humidity and high or low temperatures is also needed. The strength and durability of the joint can be increased by modifying or removing these boundary layers with different surface pretreatments [2, 6].

The oxide layer, which is naturally formed on the metal surface, tends to be in many cases porous and weak. For many metals, it is important to rebuild and manipulate these metal oxides to enhance the durability and strength of the joint. The adherence, stability, and tightness of the oxide layer on a metal surface can be increased with different surface pretreatments. For aluminum, the hydration of the surface oxides may cause the formation of oxyhydroxide AlOOH (boehmite). The transformation from aluminum oxide Al_2O_3 to boehmite AlOOH causes volume changes and induces high stresses to the bondline. The stability of the oxide against hydration can be improved with different surface pretreatments. For aluminum, different kinds of etching and anodizing techniques are used to increase the strength and durability of the adhesive joint. Nowadays, coupling agents such as silanes are more often used to create a strong bond between the adherend and the adhesive. In the case of steel adherends, there are difficulties to create naturally adherent stable oxides. Different steel grades also react in different ways to chemical pretreatments [11].

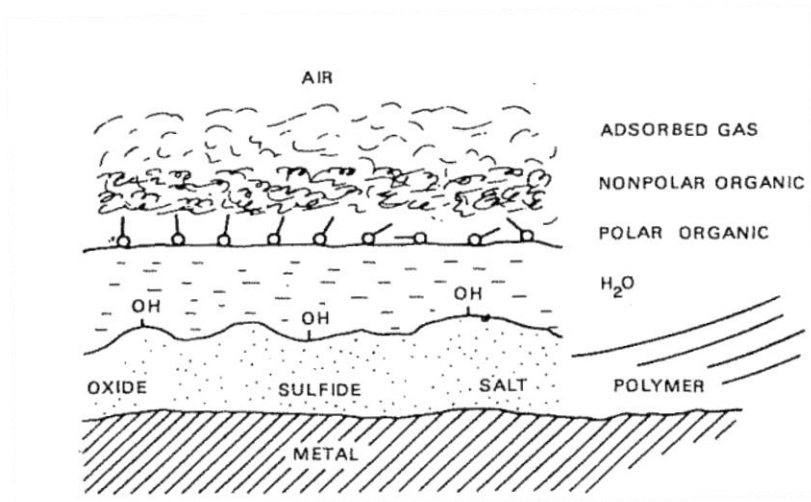

Figure 5. Adsorbed layers on a metal surface [6].

3. GENERAL CHARACTERISTICS OF ADHESIVE JOINTS IN METALS

Adhesive joining has several advantages when compared with traditional joining methods, such as welding or mechanical joining. The stresses will be distributed more uniformly throughout the joint area, and the stress concentrations will be at a lower level. The large bonding area increases the load carrying properties, and harmful microstructural changes of the adherends can be avoided due to the lack of high temperatures in the joining processes. Adhesive joining may also retard or prevent the galvanic corrosion between dissimilar metals.

The main limitations for the use of adhesive joints come from the environmental factors. High or low temperatures and high humidity together with static or dynamic loading tend to weaken the adhesively joined structure. The durability of the adhesively bonded component is dependent on the adherends, adhesive types, environmental factors such as temperature and humidity, and the stresses acting in the bonded area.

3.1 Strength properties

The strength of an adhesively joined structure is dependent on several factors. The adhesion theories described earlier in Chapter 2 explain the molecular forces between the adhesive and the adherend as well as the strength formation. The lowest strength values achieved in the joints between the adhesive and the adherend originate from the secondary bonds, such as van der Waals forces. The chemical bonding between the adhesive and the adherend will give the highest strength for the joint. The number of active groups between the adhesive and the adherend affects strongly the strength of the joint, which is dependent on the areal density of these attachment points. The density of these active (attached group) points is low when compared to the density of the potential sites to be occupied. The activity of the surface affects this density, but also the steric hindrance, the nature of the polymer molecules, is significant. The entropy can be expressed with the number of possible attachment configurations, which is multiplied by the Boltzmann's constant. The adhesive energy is the sum of the internal energy and entropy. The internal energy can be determined as the surface density of the attachment points multiplied by the bond energy per point. It is anticipated that the internal energy decreases linearly with the site occupancy of attachment points, whereas the entropy gets its maximum value at 50% occupancy. Figure 6 shows the influence of the internal energy and entropy on the free energy and the consequent strength of the polymeric adhesive joint [12].

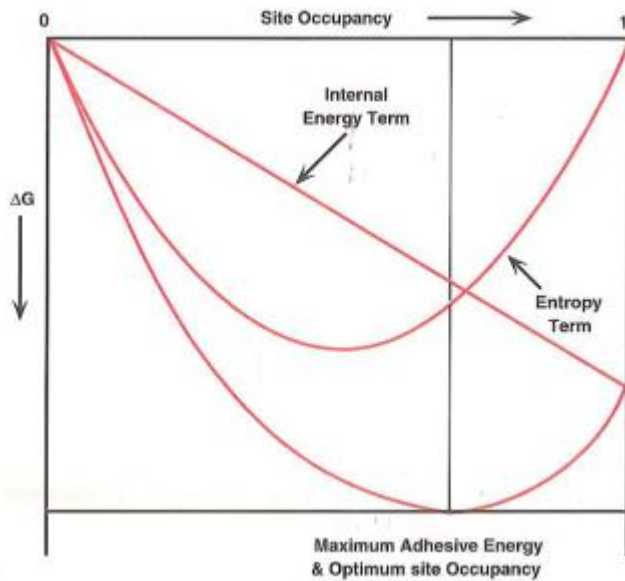

Figure 6. Dependence of the internal energy, entropy, and free energy of the joint on site occupancy. The adhesive energy is relative to the strength of the polymeric adhesive joint [12].

The strength of the adhesive joint may decrease due to the internal stresses, which are developed in the joint. These stresses might be due to the dimensional changes, such as shrinkage of the adhesive during the curing process and trapping of gases and volatiles during curing. Internal stresses may also be formed in the adhesive joint in the case of differences between the adhesive and the adherend in their thermal, strength, and elasticity properties [13].

The strength of the adhesive joint is dependent on the bond formation properties (the bond type and wetting properties) and on the internal stresses, which are formed in the bonded area. It is also dependent on the type of loading, to which the joint is exposed, and on the joint geometry. The joint design is one of the key elements in achieving the maximum strength for an adhesively joined structure. The stresses existing in adhesively bonded joints can be classified into five types: pure compression, pure tension, pure shear, cleavage, and peel stresses. These stress types may exist alone or in different combinations. Figure 7 shows the various types of loadings and stresses that can exist in an adhesive joint [14].

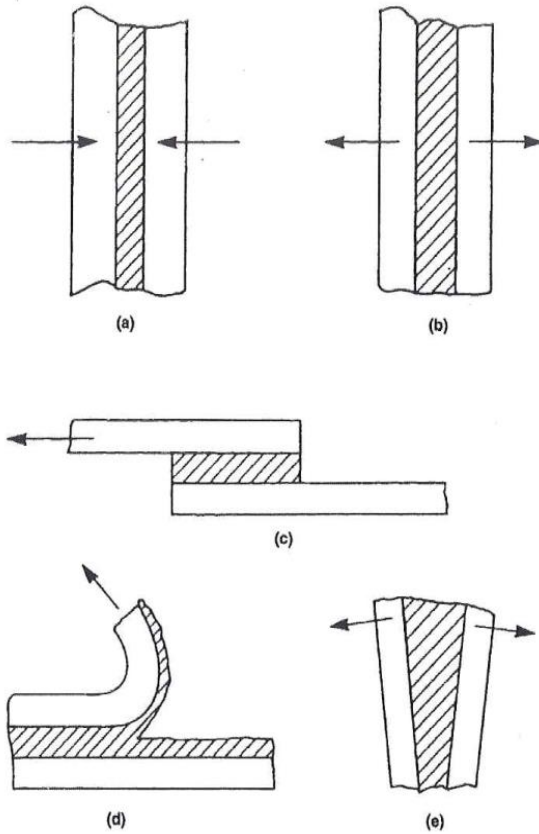

Figure 7. Schematic illustration of the various types of loadings and stresses that can exist in adhesively bonded joints, including a) pure compression, b) pure tension, c) pure shear d) peel, and e) cleavage [14].

Compressive stresses are acting perpendicular to the plane of the joint and keep the joint closed. Tensile loading acts also perpendicular to the plane of the joint, but the adherends are pulled apart and the joint tends to open. The peel loading is directed out of the plane of the joint, and it tries to open the joint non-uniformly from an edge. Very high stresses will be formed locally at the adhesive-adherend interface. Cleavage loading is of the same type as peel loading, but in the peel loading, at least one of the adherends is flexible. In cleavage loading, both of the adherends are rigid. Adhesives are weakest when subjected to peel and cleavage stresses, and adhesively joined structures should be designed so that these out-of-plane loading (peel and cleavage) stresses are minimized. The shear loading acts on the plane of the adhesive joint, causing the joint components to slide in relation to each other. In shear loading, the stresses are distributed uniformly throughout the entire bonded area, and only small stress peaks exist at the ends of the joint. Maximum strength for a stressed adhesive joint is achieved when the acting stresses are of shear type, and therefore the adhesively joined structure should be designed so that the main operating loads are of this type. This is typically achieved with lap or overlap geometry. Lap joints are easy

to produce, thin adherends can be used, and the stress type that is acting on the adhesive is shear (plus bending). The shear stress τ for completely rigid and flat adherends is:

$$\tau = \frac{F}{bl} \quad (9)$$

In Equation (9), b is the width of the joint, l is the overlap length of the joint, and F is the load. If the adherends are elastic, the situation is more complex and the formula is different. Increasing the width of the joint will increase the joint strength (stresses will be lower). The overlap length has a smaller influence on the strength, as the stresses are concentrated at the ends of the joint. Pure loading of one type, e.g., shear or tension, seldom exists in adhesive joints. These are often combined with other loading types, e.g., bending. If peel or cleavage stresses are existing, the selection of the right type of adhesive is extremely important for achieving good durability for the joint [14].

Environmental factors are strongly influencing the durability and strength of adhesive joints. Moisture and temperature are the most dominating ones, but aggressive ions such as chlorides as well as UV- radiation are in some cases also detrimental for the joint durability. Adhesives as polymeric materials are sensitive to both high humidity and high or low temperatures. These environmental factors may weaken the properties of the adhesive in many ways, and the adhesive as well as the interfaces of the joint may be aged. The aging phenomenon is one of the most important factors affecting the durability of adhesive joints [6, 11].

The failure of an adhesive joint may be of adhesive type, cohesive type, or a mixed mode failure. Adhesive failure is an interfacial failure between the adhesive and the adherend. In the case of adhesive failure, the joint is usually weak, which is typically due to the wrong or improper pretreatments of the adherend surfaces. Cohesive failure is a failure inside the adhesive. In some cases, it may be the failure of the adherend, if the adherend is weaker than the adhesive and fails before the adhesive. The failure is typically of a mixed mode, consisting of both adhesive and cohesive failure types. In practice, the failure type is characterized by the percentage of cohesive and adhesive failure types. The ideal failure is 100% of cohesive type, and it is one of the main criteria in selecting the adhesive, adherends, and pretreatment methods. In the fracture surfaces of an adhesively fractured joint, the adhesive has totally remained on one of the adherend surfaces. In the case of the cohesive fracture type, remains of the adhesive can be seen on both fracture surfaces. Mixed mode failure, consisting of both the adhesive and cohesive types of fracture, is quite usual in practice. Figure 8 shows the failure types of adhesive joints [6, 14].

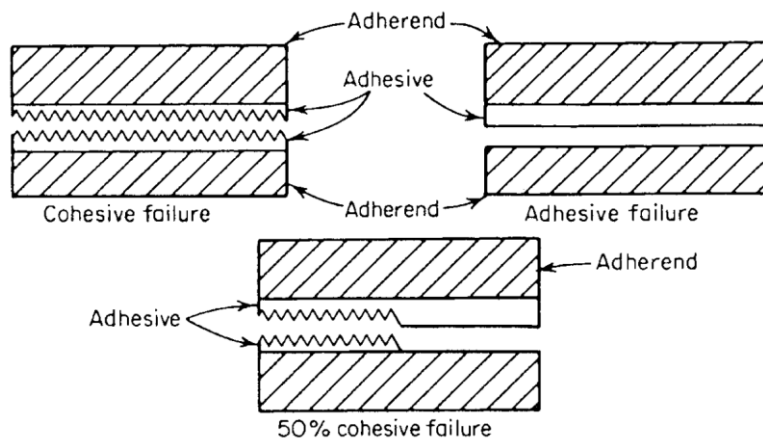

Figure 8. Failure types of adhesive joints [6].

3.2. Adhesive types

Adhesives can be classified in several different ways. To begin with, they can be divided into organic and inorganic adhesives. They can also be classified/categorized according to their chemical composition, their physical form, or their curing system. One of the most important ways to classify the adhesives is to classify them according to their use. In this way, the adhesives can be classified to structural and non-structural adhesives. Structural adhesives have high strength and they are able to support high service loads. They are expected to sustain the whole service life designed for the adhesively joined structure, and they are largely used in load-bearing structures. Structural adhesives can be stressed to a high proportion of their failure loads in the service environment, to which the joined structure is exposed. The most widely used structural adhesives are thermosets. Some thermoplastics, such as cyanoacrylates and anaerobics, are also used as structural adhesives. The polymeric resin families, which are formulated for structural adhesives, can be classified to thermosets or modified hybrids. The continuous development of chemistry has increased the number and types of new adhesives in the market. The most widely used structural adhesives are epoxies, polyurethanes, modified acrylics, cyanoacrylates, and anaerobics. The focus of this work is on epoxies, because they are widely used in metallic adhesive joints. Epoxies were also used as an adhesive in the studies described in refs. [13-16].

3.2.1. Polyurethanes

Polyurethanes (PUR) are one of the most versatile groups of all adhesives and sealants. Chemically reactive polyurethanes are available as one- or two- component systems. Polyurethanes are based on isocyanates. The NCO group in the isocyanate resin reacts with organic compounds having an extractable hydrogen atom. These

compounds can be alcohols, amines, water, and polyols. These reactions produce the urethane linkage, by which the polyurethanes are characterized. An example of these reactions is the forming of polyurea in the reaction of isocyanates with amines. Repeating urethane linkage forms in the reaction with hydroxyl-containing compounds. Typically, this reaction in polyurethane adhesives occurs between a polyisocyanate and a polyol. The most used isocyanates are toluene di-isocyanate (TDI) and methylene diphenyl isocyanate (MDI). Different kinds of polyols are used to produce different types of polyurethane adhesives. These polyols are either polyesters or polyethers.

Polyurethanes bond well to most surfaces. They have good adhesion, for example, to wood, metals, and plastics, and they are widely used in many industrial as well as household applications. Polyurethanes have excellent low-temperature properties, good flexibility, abrasion resistance, and toughness. The polyurethane based adhesive joints are tough and have high peel strength. At cryogenic temperatures, the strength of polyurethane adhesives is also high. There are also some limitations in the use of polyurethanes. For example, both cured and uncured adhesives are sensitive to moisture. Isocyanates have strong affinity to water, which makes them difficult to store. Cured polyurethanes may easily age in high humidity environments and lose their strength. The shear strength of polyurethane based adhesive joints is also of low/middle class.

Polyurethane adhesives are widely used in several industrial areas. They are commonly used in the building and construction industry, where they are used to bond parquets and other wood products. Foam-type PUR adhesives are used for sub-flooring, drywall, plywood, foamboard, fireboard, wallboard, and bricks. The ability to bond plastics as well as the flexibility and noise and vibration damping properties make the use of polyurethanes possible also in the transportation industry, where they can be used to bond windscreens in cars and commercial vehicles, interior materials of automobiles, and sidewalls of vehicles. Polyurethanes are also used in textile, packaging, electronics, and footwear industries. Semi-rigid one- and two-component PUR adhesives are used in marine installations. Foundry core binders use isocyanate-cured (PUR) adhesives as binders for sand, which is used to produce foundry sand molds [6, 15-17].

3.2.2 Acrylic adhesives

Modified acrylic adhesives, which are also known as reactive acrylics, second generation acrylics, and surface activated acrylics, can be used to join most metals and many plastics. Even the low surface energy plastics such as polypropylene and polyethylene can be joined by using certain types of acrylic adhesives. Differently from the urethane and epoxy adhesives, the acrylic adhesives cure by addition polymerization with free-radical reactions. These adhesives are composed of a

modified acrylic adhesive and a surface activator. Modified acrylic adhesives are commonly based on polymethyl methacrylates that are rubber toughened, e.g., by grafting to vinyl-terminated nitrile rubber. Modified acrylic adhesives have several advantages in their use. The curing process is fast and the shrinkage during the curing process is low. Modified acrylic adhesives have good peel and impact strength and high lap-shear strength at temperatures ranging from about -110°C to about 120°C. The weathering aging resistance including the salt spray environment is also good for acrylic adhesives. The strength of the joint is typically good also for unprepared and even oily surfaces, which is one of the reasons why the automobile industry uses acrylic adhesives. Modified acrylic adhesives are used in several applications ranging from transportation and aerospace industry to military applications. The main disadvantages of modified acrylic adhesives are their low high-temperature strength values, flammability, and the unpleasant odor of uncured adhesives [15-16].

3.2.3 Anaerobic adhesives

Anaerobic adhesives are single-component liquids in open air, but in the absence of oxygen, they will harden. For the curing reaction to initiate, the distance between the surfaces to be joined should be small. Anaerobics are cured by free radical polymerization. The curing time varies from a few minutes to several hours, depending on the activity of the surfaces to be joined. The surfaces can be classified to active, inactive, and inhibiting types. Anaerobic adhesives have good resistance to moisture, solvents, and salt spray, and they have good strength. They are typically used in nut locking, cylindrical fits, and gasketing [13, 16].

3.2.4 Cyanoacrylates

Cyanoacrylates are single component liquids, which are also known as “superglues”. The name cyanoacrylate comes from the chemical structure of these adhesives, including a –CN group, which is called a nitrile or cyano group. The cyano group is highly polar, which explains the strong adhesive nature of cyanoacrylates. The remaining part of the molecule, the acrylate part, is also polar and strengthens the adhesive nature of cyanoacrylates. The adhesion of cyanoacrylates is good to most substrates. The curing of cyanoacrylates is rapid and completes in seconds. The curing rate is dependent on the moisture content of the joint surfaces, the pH of the surfaces, and the thickness of the glue line. The curing process is initiated by atmospheric water, which is absorbed to the surfaces to be joined. The curing process is inhibited by the presence of oxygen. Therefore, the joint must be closed and the oxygen supply must be prevented to start the curing process. The curing speed is highest on alkaline surfaces. On acidic surfaces, the curing speed will be slower. The curing process is fastest when the bond line is thin. The advantages of cyanoacrylates are their fast curing, good tensile strength, and good shelf life. Limitations are their

high cost, poor peel strength, and brittleness. They also have the capability to fill only small gaps. The cyanoacrylates are used to produce high integrity parts for aircrafts, and they are widely used in various electronic, automotive, and maintenance applications [13-16].

3.2.5. Epoxies

Epoxies can be considered as the most versatile family of adhesives, forming strong and durable joints with many types of substrates. Epoxy adhesives have good wetting properties, and their degree of adhesion is high to nearly all substrates except for some untreated plastics and elastomers with low surface energy. The strong adhesion of epoxy adhesives is based on the interfacial hydrogen bonding. The hydroxyl groups along the molecular chain are strongly adhered to oxide and hydroxyl surfaces. Epoxy adhesives have high tensile and shear strength and high resistance to oil, moisture, and many solvents. Typically, epoxy adhesives have low shrinkage during curing and high creep resistance under prolonged stressing. The formula of an epoxy adhesive can be modified, and in that way, widely varying properties can be achieved. The properties can be modified by adding organic or inorganic fillers and components, and by selecting the epoxy resin, the curing agent, and the reaction mechanism from several possibilities. The epoxy adhesives can have a huge assortment of end-properties depending on the type of the resin, the curing agent, and the specific formulation that is being used [13-16].

Most structural epoxy adhesives are either single component heat curing adhesives or multiple component adhesives that will cure either at room temperature or at elevated temperatures. The epoxy adhesives, which cure at elevated temperatures, have typically the highest shear strength and the best heat resistance. They typically also have better environmental resistance than other epoxies, but their toughness and peel strength values are usually low due to high rigidity.

Epoxy adhesives are composed of an epoxy resin, a curing agent, and eventual additives or modifying agents. In single component adhesives, the curing agent is incorporated into the resin. The base of the epoxy molecule is the oxirane group, a three-member ring-containing oxygen. Figure 9 shows the oxirane ring structure [6,15].

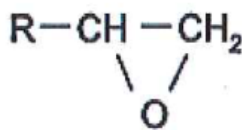

Figure 9. The epoxy base structure, the oxirane group [6].

The most used base epoxy resin is the diglycidyl ether of bisphenol A, DGEBA. Figure 10 shows the structure of the DGEBA molecule. Another widely used epoxy resin is the diglycidyl ether of bisphenol F, DGEBF, which allows greater possibilities to adjust the formula. In special applications, there are also other types of resins in use to obtain some specific properties such as low viscosity, increased flexibility, increased reactivity, improved color stability, or clarity.

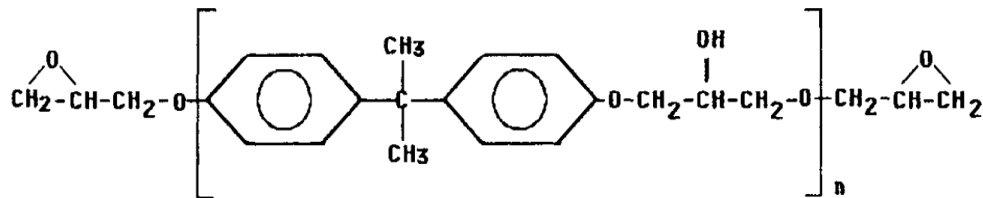

Figure 10. General structure of the DGEBA molecule [6].

The versatility of epoxy adhesives is high because there is a large number of possible curing agents with varying properties. The curing agents affect the cohesive strength, hardness, and durability of the adhesive. The adhesion is more dependent on the surface energy of the used resin than on the curing agent. The use of different curing agents affects also the shear strength, peel strength, and environmental resistance of the adhesive. The selection of the curing agent depends on the application requirements. Amines or polyamides can be used for the room temperature curing of the DGEBA epoxy resin. At elevated temperatures, the DGEBA resin can be cured with anhydrides. Some epoxies can be cured by a polymerization reaction that is initiated by strong bases or strong acids [13,15].

Typically, the cured epoxy adhesives are brittle. The toughness of epoxy adhesives can be improved by adding different toughening agents, such as rubber particles (inclusions, regions), to the epoxies. For example, in the case of DGEBA and DGEBF epoxy resins, the toughness is increased by adding nitrile rubber. Other properties of the epoxy adhesives can be improved by compounding different kinds of modifiers and additives to the adhesive system. For example, the strength, flow properties, and heat resistance can be modified. The viscosity can be reduced by using diluents. With mineral fillers, the costs can be lowered and the thermal expansion coefficient can be modified, and so forth. Also nanoscale reinforcements to improve the mechanical, electrical, and thermal properties may be added. Sadigh [18] added reduced graphene oxide (RGO) particles to an epoxy adhesive and noticed that the particles increased the strength of the joints in both dry room temperature environment as well as in the moist environments, as compared to the results of the non-reinforced (0% RGO) adhesive joints. Vertuccio et al. [19] used Multi Wall Carbon Nanotubes (MWCNTs) in epoxy adhesives to increase their electrical properties. They also used liquid rubber, i.e., carboxyl-terminated butadiene acrylonitrile copolymer (CTBAC), to enhance the

flexibility and other mechanical properties such as the shear strength of the adhesives [6, 13, 15, 18, 19].

Epoxy hybrid adhesives have been developed for demanding applications such as the aerospace industry. By blending/combining the epoxy resin with some other resin, properties specific to that combination can be achieved. For example, when blending an epoxy resin with a phenolic resin, the high temperature resistance is improved. Similarly, when blending epoxy and nylon, the toughness and peel strength values are improved as compared with the “pure” epoxy adhesive. By blending epoxy with polyurethane, the peel strength of epoxy adhesives increased [15].

3.3. Aging characteristics

Aging can be defined as a combination of chemical and physical changes in a material, which will change the mechanical and physical properties of the material over time, and shorten and limit its service/application life. The aging process can be divided into physical and chemical aging processes according to their effects on the short-term and long-term properties. Chemical aging processes are usually related to long-term changes, and physical aging processes to short-term changes [20].

The long-term durability of adhesive joints and the prediction of their lifetime have become more and more important. As the adhesives are polymeric materials, they are sensitive to environmental factors. Polymeric materials differ from metals and ceramics, as they consist of linear covalently bonded polymer chains that are kept together by weaker forces between the chains. Metals and ceramics mainly have three-dimensional crystalline structures. Polymers are constructed of macromolecules, which are built from long carbon atom chains with different side groups and/or unsaturated bonds. These groups react easily with environmental substances or effects such as water, oxygen, ozone, and radiation. This aging phenomenon is so-called chemical aging, and it cannot be reversed as it changes the chemical structure of the molecules by breaking the bonds and forming chain scissions as well as new cross-linking points. Heat accelerates these reactions, and therefore temperature is one of the main factors influencing the degradation and aging of adhesive joints. These reactions are dependent on the adherends, adhesives, interfaces, and their properties. The interfaces between the adhesive and the adherend are inhomogeneous, and their chemical and physical properties differ from the properties of both the adhesive and the adherend. The aging process is limited by the diffusivity of the surrounding media and the reaction rate between the polymer and the medium. The reaction rate is also dependent on the state of the interfacial phenomena, and consequently the aging process depends significantly on the characteristics of the interface [20-22].

4. AGING OF ADHESIVE JOINTS

The environment has an influence on the durability and mechanical properties of adhesive joints. In many cases, the strength of the joint will decrease due to this influence. The environment affecting the adhesive joint can be considered as the sum of all individual factors having an influence on the joint properties. This includes temperature, moisture, and radiation, and in a wider sense, also the mechanical forces. The environment can also contain aggressive ions such as chlorides. From the environmental factors, moisture and temperature are the dominating ones. Moisture is one of the most common degrading agents in adhesive joints, and it may weaken the joint by several ways. As the adhesives are polymeric materials, there is an upper temperature limit for their use. It is also worth noting that high temperatures will accelerate the chemical reactions caused by other environmental factors, and together with moisture and/or static or dynamic loading, they tend to weaken the joint [11, 21, 23].

Besides the environment, also the materials and stresses have an influence on the durability of adhesive joints. The bond durability is dependent on the adherend, the adhesive, and the joint interfaces. Surface chemistry and morphology influence the bond formation and stability of the joint. The stability of the adherend and its surface determines the ultimate limit of joint durability. The stability of the interface between the adhesive and the adherend can be remarkably improved by different surface treatments of the adherends. The level and type of stresses, which are existing in the joint, affect the durability of the joint and usually weaken its properties. Cyclic stresses may degrade the joint more rapidly than constant static stresses [11]. The stresses may also increase the degrading influence of other environmental factors on the joint. For example, the rate of moisture diffusion in the adhesive may increase due to the presence of stresses [11, 22].

4.1. Manifestation of aging

The strength and durability of the adhesive joint are dependent on the properties of the adhesive and the adherend, as well as on the properties of the interfaces between them. In adhesively bonded metals, aging can be seen as weakening of the adhesive itself and of the interfacial structures, and as an eventual corrosion of metal adherends.

Temperature and the presence of water affect the adhesive in many ways. Moisture is the most dominant environmental factor weakening the adhesive. Moisture tends to cause plasticization of the adhesive and lowering of its glass transition (T_g) temperature. A significant amount of swelling may also occur. The decrease of T_g also lowers the highest use temperature of the adhesive. Plasticization of the adhesive may

reduce the physical bonding of the adhesive to the adherend and consequently decrease the joint strength. On the other hand, it may also cause stress relaxation or crack blunting in the adhesive and in that way improve the durability of the joint. In moist environments, the plasticization or softening of the adhesive typically decreases the modulus and strength of the adhesive. The plasticization and weakening of the adhesive have been found to be dependent on the rate of water diffusion in the adhesive. Swelling tends to cause stresses in the joint and consequently weaken it. The moisture may also change the failure type of the adhesive joint. When the failure is of adhesive type, the failure is located at the interface between the adherend and the adhesive, revealing the poor bonding between the adherend and adhesive. The cohesive failure is located inside the adhesive or the adherend. The failure is often of the mixed mode type so that one part of it is of cohesive type and another part of adhesive type. Aging and high stresses may cause the failure of an adhesive joint to occur adhesively. This is much more dangerous for the joint than the cohesive type of failure, and the durability of that kind of joint is generally poor. Chemical bonds between the adhesive and the adherend may stabilize the interfaces against aging and increase the durability of the joint [6, 14, 20-22, 24].

The stability of the adherend and its surface influence remarkably the durability of the joint. If the adherend becomes degraded, the bond line will be damaged and the joint will fail. Moisture may cause hydration of the metal oxide layer at the interface, resulting in the strength degradation of the adhesive joint. Many metal oxides such as aluminum and steel oxides may undergo this hydration. The formed metal hydrates have a weak bonding to the base metal and cause easily the failure of the joint. The failure due to moisture is typically caused by the formation and propagation of flaws or cracks at the interface. The absorbed water may reduce the cohesive energy and alter the bond strength at the crack tip. Joint durability can be improved by increasing the resistance of the metal oxide against hydration. This can be achieved by different surface treatments. Moisture may also cause corrosion of metal adherends and consequently weaken the joint [11, 22, 24-25].

The degradation rate of the joint is also dependent on temperature. High temperatures will accelerate the chemical processes weakening the joint. All polymers will degrade at elevated temperatures, and the degradation rate is increased by the supply of oxygen (oxidative degradation). Thermal stresses may form in adhesive joints due to the different thermal expansion coefficients of the adhesive and the adherend [21, 26].

4.2 Factors affecting the aging behavior

There are several factors affecting the aging behavior of adhesive joints. These factors can be classified to environmental, material, and stress categories. Moisture, humidity, and temperature are the most dominating factors among the environmental factors affecting the aging behavior. The adherend and its surfaces influence also the

durability of the adhesive joint, as described in section 4.1. The stress level and stress type also affect the aging behavior of the adhesive joint. All these factors may lower the durability of the adhesive joint remarkably, and extremely dangerous they are to the durability of the adhesive joint when they all exist simultaneously [6, 11, 22].

4.2.1 Humidity and water diffusion

Water can be considered as the most dominant factor influencing the durability of the adhesively joined structure. Water may lower the durability and strength of the joint in several ways. Water is a problem for the adhesive itself and consequently for the whole adhesive joint. Water may enter the joint in several ways. Water may diffuse through the adhesive. There may also be water diffusion through the adherend, if the adherend is permeable to water. There may be capillary propagation of water through cracks and crazes in the adhesive, as well as transport of water along the interfaces [25, 27-29].

Water affects the adhesive and changes its properties. The water entering the adhesive joint interfaces is also a problem. The water molecule is highly polar and has a high tendency to migrate along the interfaces in the case of high surface energy adherends, and also in the case of adhesives that have a strong tendency to absorb water. Water molecules have the ability to form hydrogen bonds with suitable groups on the surface of the solid. Water may displace or weaken the van der Waals bonds, hydrogen bonds, etc. in the joint between the adherend and the adhesive. When the van der Waals interactions are weakened, also the thermodynamic work of adhesion will be lower and the durability and strength of the joint will be reduced. It is important to remember that lowering of the thermodynamic work of adhesion is valid and reduces the durability of the adhesive joint in the case of physical adsorption (van der Waals interaction, hydrogen bonds, etc.). Chemical bonds between the adhesive and the adherend typically strengthen the joint by counteracting the thermodynamic displacement of adhesive bonds by water. Chemical bonds will not be broken so easily when moisture is present. As described above, water may lower the strength of the joint by causing hydration of the metal oxide layer at the interface. Aluminum and iron oxides are examples of common metal oxides that can undergo hydration. The hydrated metal oxides become gelatinous, and they can be considered to form a weak boundary layer due to the weak adhesion to the base metal. On aluminum surfaces, the aluminum oxide Al_2O_3 hydrates to AlOOH oxyhydroxide (boehmite). Boehmite has a low mechanical strength, and due to the stresses that are formed during the hydration, the joint will weaken remarkably. When the original oxide is converted to hydroxide, it adheres poorly to the aluminum surface. Failure surface analysis has shown that the adhesion of the hydroxide to aluminum is weak. The hydroxide that is formed separates easily from the surface and causes the failure of the joint. Figure 11 shows the propagation of a crack near the hydroxide-metal interface due to the hydration of aluminum oxide [22, 25, 29, 30-32].

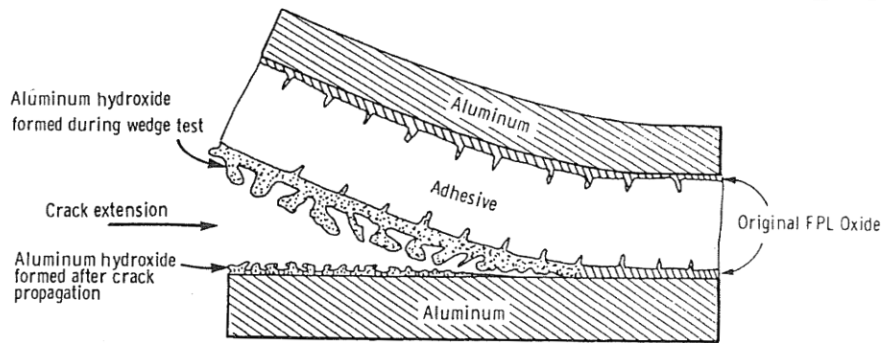

Figure 11. Hydration of aluminum surface oxide causing bond failure [22].

The durability of the joint can be remarkably improved by using adherend surface pretreatments, which stabilize the oxide against hydration. There are, for example, different types of anodizing and etching techniques for stabilizing and strengthening the oxide layer on metal surfaces. Different types of chemical pretreatments also enable the formation of chemical bonds between the adhesive and the adherend, and consequently increase the resistance of the joint against the detrimental effects of water [22, 25, 31].

The durability of the joint is strongly dependent on the ability of the adhesives to absorb water. Many adhesives absorb easily moisture because their molecular backbone is made up of many hydrophilic units. Under wet or humid conditions, moisture may easily cause swelling and deformation of the adhesive, breaks the chemical bonds and weakens the polymer backbone. The water uptake measurement of the adhesive ensures that the possible saturation level has been reached and the influences on the adhesive can be resolved. The water uptake properties of adhesives can be easily detected by immersing adhesive films in water or exposing them to humid environment conditions and by measuring their weight increase over time. The results are typically presented in the form of fractional mass uptake versus the square root of time. Figure 12 shows water uptake results for an epoxy adhesive [27-28, 33-35].

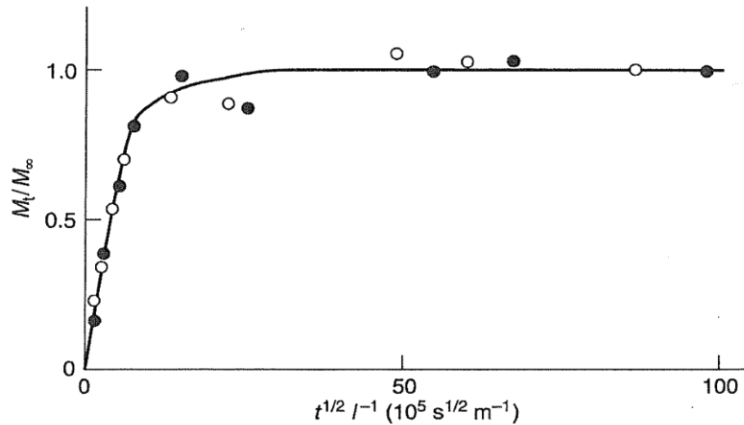

Figure 12. Water uptake results for an epoxy adhesive [28].

According to Figure 12, the typical water uptake behavior of many adhesives splits into different stages. In the first stage, the water uptake M_t / M_e increases smoothly as a function of the square root of time, and in the second stage the equilibrium has been reached. The diffusion coefficient of water in the adhesive can be determined from the slope of the linear part of the rising curve in Figure 12, and equilibrium stage (M_e) from the horizontal part of the curve. In the first stage of water uptake, the slope of the curve in Figure 12 obeys the Fickian diffusion behavior. This type of behavior has been measured for several adhesives. Fick's first law for diffusion is:

$$F_x = -D \left(\frac{\partial c}{\partial x} \right) \quad (10)$$

where the diffusion flux F is the rate of material transfer per unit of area in a unit of time. In Equation (10), F_x is the diffusion flux in direction x , D is the diffusion coefficient, and $\frac{\partial c}{\partial x}$ is the concentration gradient in the x -direction. The diffusion coefficient is a proportionality constant, which describes the mobility of a species in a diffusion medium. It may depend on the concentration and several other variables. Fick's first law is valid in steady state diffusion, where the concentration does not change with time. Transportation of moisture through a substance where the concentration increases proportionally decreases the diffusion flux F of that element across the distance in order to conserve mass. This can be described by the Fick's second law of diffusion, which is valid in the non-steady state diffusion. It has several forms, of which the relevant form here is:

$$\frac{\partial c}{\partial t} = D \left(\frac{\partial^2 c}{\partial x^2} + \frac{\partial^2 c}{\partial y^2} + \frac{\partial^2 c}{\partial z^2} \right) \quad (11)$$

This is the three-dimensional form of the Fick's second law of diffusion. It describes the build-up or decay of the concentration of the diffusing species with time, i.e., $\frac{\partial c}{\partial t}$. When the diffusion is occurring only in the x-direction, Equation (11) gets the form:

$$\frac{\partial c}{\partial t} = D \left(\frac{\partial^2 c}{\partial x^2} \right) \quad (12)$$

For example, Crank [28] has given a solution for the Fick's second law of diffusion. For a thin film with thickness L, immersed in a liquid or exposed to vapor at a constant pressure, the solutions gets the form:

$$\frac{M_t}{M_e} = 1 - \sum_{n=0}^{\infty} 8 \exp \frac{[-D (2n+1)^2 \pi^2 t / 4L^2]}{(2n+1)^2 \pi^2} \quad (13)$$

In Equation (13), M_t is the mass absorbed at time t and M_e is the absorbed mass at the equilibrium (corresponding to the plateau in Fig. 12.) At short times, at times before the equilibrium stage, and just at the equilibrium stage, Equation (13) gets a simple form:

$$\frac{M_t}{M_e} = 4(Dt/\pi)^{1/2} / L \quad (14)$$

The diffusion coefficient D can be calculated from Equation (14) as:

$$D = \frac{\text{slope}^2 \pi}{16} \quad (15)$$

The Fickian diffusion model is not always suitable for describing the moisture uptake of adhesives, and several models have been presented to describe the non-Fickian moisture uptake. Non-Fickian moisture uptake is observed especially when operating

below the glass transition temperature (T_g). This behavior can be explained for example as a relaxation process and/or by the chemical reactions between the water molecules and the polymer chains in the adhesive [39]. Berens and Hopfenberg [31a] assumed that the uptake can be divided into two parts: a Fickian diffusion-controlled uptake and a polymer relaxation-controlled uptake. According to the theory of Carters and Kiblers [31b], the moisture in a polymer network can be either free or bound. By studying the absorption mechanisms, the researchers have found that the water molecules have a double nature in polymers. Hydrophilic sites of adhesives form easily bonds with the water molecules. In the absorption process, the water molecules first bind to the hydrophilic groups of the adhesive and become then energetically more favorable than free unbound water molecules. Loh et al. [31c] have proposed a dual uptake model, which combines the two Fickian diffusion models. According to this model, two different water uptake processes can be seen working at the same time. For some epoxies, this dual model has been found to work at higher temperatures (at 70°C as an example), while at lower temperatures (below 50°C) the second uptake was absent. Some researchers have noticed that the dual Fickian model needs less experimental information and still provides good correlation with the experimental results. For some adhesives an additional moisture uptake has been noticed, which the Fickian diffusion or the dual Fickian model do not describe well enough. For those cases, the so-called delayed dual Fickian model has been presented. Figure 13 shows the moisture uptake behavior of an epoxy adhesive as represented by different models and compared with experimental data. Figure 13 shows the secondary moisture uptake process, which is described by the delayed dual Fickian model [31, 35, 36-38, 39-41].

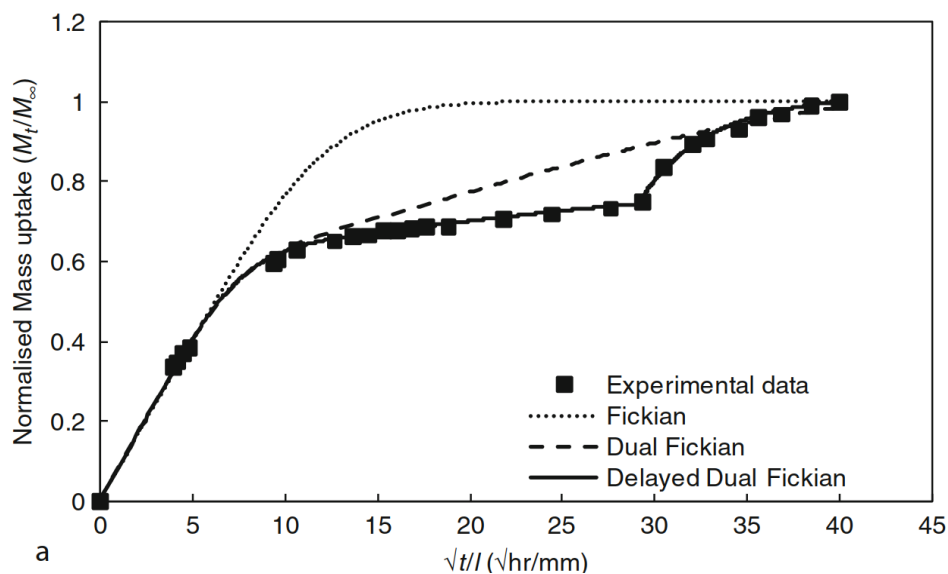

Figure 13. Moisture uptake behavior of an epoxy adhesive with the secondary uptake process [31].

The measurements of the water uptake values and aging characteristics for several adhesives and adhesive types have shown that under the conditions where the relative humidity is below 50% RH, the adhesive joints are not largely weakened. Figure 14 shows the dependence of M_e on the relative humidity r.h. (RH) (%) for an epoxy adhesive [28].

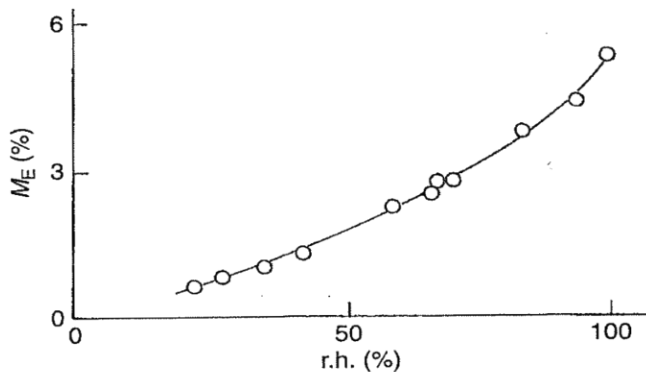

Figure 14. Dependence of water absorption on the relative humidity r.h. (RH) (%) for an epoxy adhesive [28].

Several researchers have shown that although the joints are weakened by the exposure to high humidity of air (e.g., 80-100%RH), the adhesive joints can be exposed for long periods of time to low humidities, 50% RH or less, without significant weakening of the joint. When the strength of the adhesive joint is measured as a function of time at different humidity levels, it has been noticed that the strength decreases rapidly in the beginning under both low and high humidity conditions and reaches an equilibrium at longer times. The equilibrium level of strength is lower at high humidity values. Figure 15 shows the strength reduction of an adhesive joint as a function of time when the joint is exposed to humidity values of 50% RH and 100%RH at the temperature of 50°C [28, 31, 36].

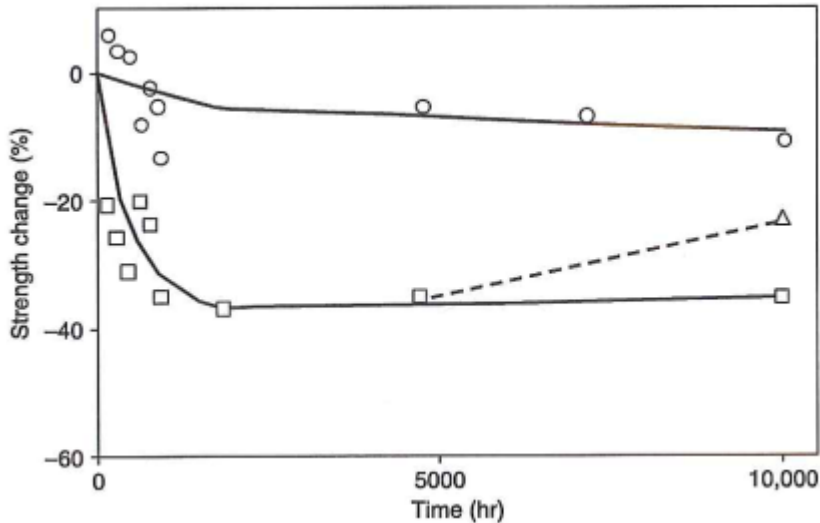

Figure 15. Percentage strength change of an aluminum alloy joint bonded with a nitrile-phenolic adhesive as a function of time. Joints are exposed to humid air at the temperature of 50°C and at the relative humidity values of 50%RH (o) and 100% RH (□). Joints marked with Δ are exposed at 100% RH for 5000h and then kept for another 5000h at 50%RH [31].

Figure 15 shows that the strength of the joints exposed to higher humidity (100%RH) at 50°C decreases first quite rapidly (40-60%), after which the decrease tends to level out. There is no or just a small amount of initial weakening in the joints, which are exposed to lower humidity (50%RH) at 50°C. Figure 15 also shows that a part of the strength loss is recovered for the specimens that are first exposed at 100%RH for 5000 h and then stored for another 5000 h at 50% RH, when compared with the strength values of the specimens kept for 10 000 h at 100% RH. This reveals that the decrease of the strength at high humidity values is partly reversible. Gledhill et al. [31d] have proposed that there must exist some critical concentration of water in the adhesive and a corresponding relative humidity of the environment to lead to a marked weakening of the joint [31, 37].

Water causes plasticization of adhesives. This tends to lower the glass transition temperature (T_g) of the adhesive, and consequently it decreases the highest service temperature of the adhesive joint. An increase in the moisture content of the adhesive decreases the T_g temperature of the adhesive. Figure 16 shows the $\tan \delta$ peak, representing the T_g temperature as measured by the differential thermomechanical analysis (DTMA) for a modified epoxy adhesive containing different amounts of absorbed water. Figure 16 reveals the influence of the moisture content of the modified epoxy adhesive on the T_g temperature of the adhesive. For a dry adhesive, the T_g temperature is approximately 130°C, but for the adhesive which has absorbed 4.4% of water, it is reduced to about 85°C [28, 31, 42-46].

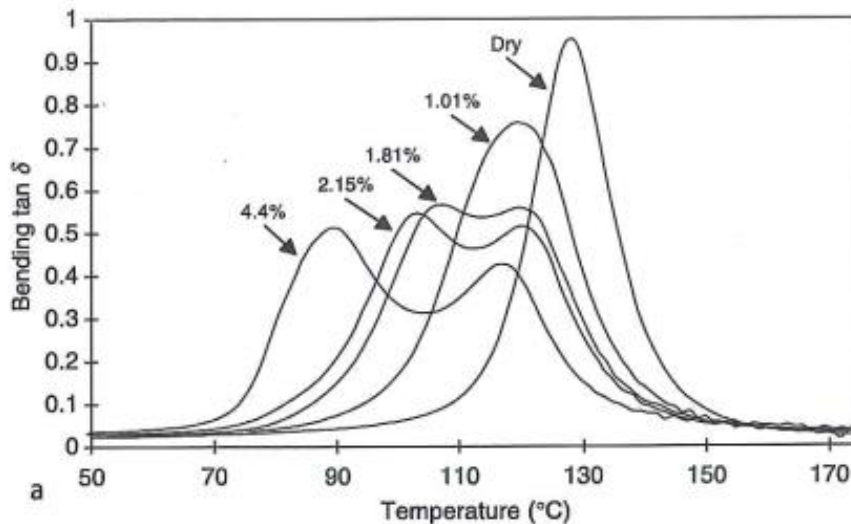

Figure 16. DTMA results for a modified epoxy adhesive with different amounts of absorbed water [31].

Some researchers have noticed that the T_g temperature decreases linearly with increasing moisture content so that approximately 1% absorption of water leads to a decrease of about 8°C in the T_g value of epoxy adhesives [46]. The strong decrease of T_g due to the moisture explains the strong influence of moisture on the weakening of the mechanical properties of the adhesive especially at higher temperatures. When the aging time increases and the water uptake of the adhesive has reached its saturation level, the decrease of the glass transition temperature of the adhesive seems to level out. This saturation level of water uptake has been noticed to be about 3% for some epoxy adhesives. For some adhesives, it has also been noticed in the DTMA results of the T_g temperature that when the absorbed moisture content of adhesives is at the saturation level, two distinct peaks of T_g exist instead of one peak. The first peak is the peak from the saturated material, while the second peak at a higher temperature comes from the partially dried material [31, 46].

Plasticization of the polymeric base due to humidity decreases the strength and the elastic modulus of the adhesive. Han et al. [47] have studied the influence of the moisture content on the mechanical properties of an epoxy adhesive. They noticed that when the moisture content increased above the saturation level, the Young's modulus dropped by about 15% when compared with dry unaged specimens. Increasing water content has also been noticed to increase the elongation at break, but this has been found to recover after drying [28, 47].

The diffusion of water through the adhesive is the dominant process influencing the properties of aging adhesive joints of metals. Water may also be absorbed to the joint along the adhesive/adherend interfaces and diffuse from there to the adhesive. The decrease of the strength of an adhesive joint can also be caused by the degradation

of the adhesive/adherend interface besides the weakening of the adhesive. Pre-existing cracks and debonded areas at the interfaces are favorable uptake sites for water. In many cases, the joint failure is a result of the plasticization of the adhesive and the weakening of the metallic substrate/adhesive interfacial area. Water may displace the adhesive bonds on the adherend surface and, as previously mentioned, it may reduce the thermodynamic work of adhesion. It may also cause corrosion of the adherend surfaces. The eventual electrochemical corrosion of metallic adherends will lead to the degradation of the joint between the adhesive and the adherend. The moisture itself may cause weakening of the joint but, for example, saline environment accelerates the corrosion and degradation of the joint properties. The durability of the adhesive joint against corrosion can be remarkably increased with proper surface pretreatments of the adherends [43, 44, 48].

Water can cause cracking and crazing of adhesives and modify the behavior of the crack tip during fracture. Cracks may propagate in the adhesive joint along the adhesive or at the interfaces of the joint. A cohesive type of fracture inside the adhesive or an adhesive type of fracture at the interfaces may then exist in the aged joint [29, 49].

4.2.2 Temperature

Temperature has a strong influence on the behavior and durability of adhesive joints. Higher temperatures typically accelerate the chemical reactions. Diffusion of water in the adhesive is a thermally activated process, and consequently it is dependent on temperature. The diffusion coefficient of water in the adhesive obeys the Arrhenius equation:

$$D = D_0 \exp\left(-\frac{E_D}{RT}\right) \quad (16)$$

In Equation (16), D is the diffusion coefficient at temperature T , D_0 is a constant, E_D is the activation energy of diffusion, R is the universal gas constant, and T is the absolute temperature. According to Equation (16), the diffusion of water accelerates when the temperature increases. High temperatures together with moist environments weaken the joint rapidly. When the water uptake reaches its saturation level M_e , the water uptake of the adhesive is not strongly dependent on temperature. Heshmati et al. [41] noticed in their study on a two-component epoxy adhesive that at a higher temperature (45°C) the diffusion was accelerated when compared to a lower temperature (20°C) but that at the saturation level the moisture content was the same for specimens aged at both temperatures [28, 31, 40-41, 50].

For polymeric materials, there are upper service temperature limits, below which the adhesive must be used. Above the T_g temperature, the structure and properties of polymers are changed. Polymeric materials are typically hard and rigid below the T_g temperature, but become soft and leathery above T_g . The translational or rotational movements of atoms forming the backbone of the polymer are restricted below the T_g temperature, while above the T_g temperature molecular movements can occur. Hard, rigid, glassy and leathery polymers are all used as adhesive materials, but due to the large changes in the mechanical properties of adhesives at the T_g temperature, they should not be used at or above the temperature region of T_g . Big changes in the mechanical properties such as strength and elastic modulus will occur, when the temperature increases above T_g . Structural adhesives are typically used in rigid structures with high elastic modulus, and consequently they should be used below their glass transition temperature. At elevated temperatures, the adhesives will thermally degrade. This depolymerization will occur when free radicals are formed at high temperatures, and the resulting homolytic fission of chemical bonds starts [26]. Although this thermal degradation of adhesives can occur in the absence of air, the rate of the degradation is increased in the presence of oxygen. Oxidative degradation of adhesives is prevented when impermeable adherends such as metals are used. Very low temperatures may also weaken the adhesive and the adhesive joint, but typically the adhesive joints have their maximum strength at subzero temperatures. When the temperature increases, the strength of the joint decreases [26, 51].

As discussed before, thermal stresses may be formed in the adhesive joints due to the differences in the thermal expansion coefficients between the adhesive and the adherends. The coefficients of linear thermal expansion are typically much higher for the polymeric adhesives than, e.g., for the metallic adherends. Above the T_g temperature, the thermal expansion coefficients of polymeric adhesives are even 2.5 to 3.5 times higher than at temperatures below the T_g temperature. Thermal expansion of adhesives can be decreased by incorporating mineral fillers, such as finely dispersed silica or alumina, in the adhesives. In this way, it is possible to decrease the stresses, which are easily formed when the adhesive joint is cooled down or warmed up [26, 51].

4.2.3 Stresses

Stresses in the adhesive joints can be either internal or external. Internal stresses are formed, for example, when there are differences in the physical properties of the adhesive and the adherends. External stresses can be dynamic or static in nature. Stresses as such do not limit the service life of the adhesive, if the ultimate strength and the ultimate elongation levels are not exceeded. External loading may cause localized stress concentrations in the adhesive joint, and the magnitude of the peak stresses can be very high. This can be minimized/avoided with a proper and careful

design of the adhesive joint. It is also good to remember that the strength of even high-strength adhesives is quite low as compared with the strength of metals [6, 50].

Cyclic stresses can cause fatigue failure in the adhesives. Adhesive joints have typically good fatigue properties as compared with some other joining methods, such as riveting, spot welding, and mechanical fastening. This is due to the more homogenous stress distribution in the adhesive joints as compared with the other methods. In reciprocating loading, the adhesives can convert the mechanical energy to thermal energy, which increases the temperature of the adhesive. Consequently, fatigue failure can occur by both thermal and mechanical degradation [6, 50].

Stresses together with the environmental exposure to moisture and temperature tend to weaken the adhesive joint rapidly. The critical stress level below which the failure does not occur will be lower in the presence of moisture. Several studies have shown that the adhesive joints tend to weaken more rapidly, if they are stressed during the “wet” climate exposure (water and temperature) as compared with the dry climate exposure. Stresses may modify and increase the rate of water diffusion (the water diffusion coefficient D is increased) when the structure is stressed. When the water uptake is saturated, the stresses may be reduced. Han et al. [47] noticed in their study that the moisture diffusion rate was greatly increased when the specimens were stressed. Stresses also increased the saturated water uptake value by over 25%. According to their results, the reason for the increase of both the diffusion coefficient and the saturation level of the water uptake is the increase in the free volume of water in the bulk adhesive under loading [43]. Ashcroft et al. [31] exposed adhesive joints to hot/wet climate for six years so that part of them were stressed. For some adhesive joints, they noticed that at higher stressing levels the strength of the adhesive joints was reduced to zero, while at smaller stressing levels there was still a significant fraction of the strength of the joint remaining after the exposure. The stresses can also increase the transport rate of moisture in the adhesive due to the crazing and formation of microcracks. These cracks make the water migration to the adhesive easier and the adhesive will weaken. Failure in the case of solvent crazing occurs by a brittle fracture mechanism. When the joint is highly stressed and moisture and temperature are also affecting, the crazing may occur below the glass transition temperature of the adhesive. Stresses together with moisture will increase the crack growth rate in the adhesive [6, 31, 47, 50].

5. METHODS FOR IMPROVING THE ADHESION AND AGING BEHAVIOR

All environmental aging factors described in Chapter 4 affect the durability of adhesive joints. Surface pretreatment, which is properly selected for the adhesive joint, is the key element in improving the adhesion and aging behavior. The aging resistance of the adhesive joint can also be increased by several other ways, including proper design, selection of the geometrically right type of joint, proper selection of the adhesive, and encapsulation of the joint from the environment. Joint failures mainly occur due to the wrong pretreatment method or due to the improper accomplishment of the pretreatment.

5.1 Surface pretreatments

Surface pretreatment is one of the most important factors for improving the durability and strength of the adhesive joint. Proper selection of the pretreatment ensures the reliable use of the adhesively joined structure. Several factors influence the selection of the pretreatment method. The adherend type, the size of the components to be joined, joint design, adhesive selection, and the joining process are things to be considered. Proper surface pretreatment ensures that the weakest link in the adhesive joint is within the adhesive or organic material layer and not in the adhesive-adherend interface. The fracture is then of cohesive instead of adhesive type. It is also important to remember that a carefully and properly made surface pretreatment has little value if an unsuitable adhesive is used or the joint is not properly fabricated [52, 53].

The surface pretreatments that are widely used for metal adherends can be classified into three categories: 1. degreasing (cleaning) methods, 2. abrading methods, and 3. chemical methods. Depending on the used pretreatment method, its purpose is to remove material, change the surface topography, and possibly modify the chemistry of the surface of the adherend. Table 1 shows the effects of different pretreatments on the strength of the adhesive joints of different metal adherends [52].

Metal adherends typically have high surface energy and are easily adhesively bonded, while plastics have low energy surfaces requiring different types of surface pretreatments to modify the chemical nature of the surfaces. Typical methods to pretreat the metal adherends are bare degreasing, degreasing, abrading and removing the loose particles, or degreasing and modifying the substrate surface by chemical or electrochemical methods.

Table 1. Influence of different surface pretreatments on the strength of different adhesive joints [52].

<u>Adherend</u>	<u>Treatment</u>	<u>Adhesive</u>	<u>Shear strength</u>	
			<u>psi</u>	<u>MPa</u>
Aluminum	As received	Epoxy	444	3.06
Aluminum	Vapor degreased	Epoxy	837	5.77
Aluminum	Grit blast	Epoxy	1751	12.1
Aluminum	Acid etch	Epoxy	2756	19.0
Aluminum	As received	Vinyl-phenolic	2442	16.8
Aluminum	Degreased	Vinyl-phenolic	2741	18.9
Aluminum	Acid etch	Vinyl-phenolic	5173	35.7
Stainless steel	As received	Vinyl-phenolic	5215	36.0
Stainless steel	Degreased	Vinyl-phenolic	6306	43.5
Stainless steel	Acid etch	Vinyl-phenolic	7056	48.7
Cold-rolled steel	As received	Epoxy	2900	20.0
Cold-rolled steel	Vapor degreased	Epoxy	2910	19.9
Cold-rolled steel	Grit blast	Epoxy	4260	29.6
Cold-rolled steel	Acid etch	Epoxy	4470	30.8
Copper	Vapor degreased	Epoxy	1790	12.3
Copper	Acid etch	Epoxy	2330	16.1
Titanium	As received	Vinyl-phenolic	1356	9.35
Titanium	Degreased	Vinyl-phenolic	3180	21.4
Titanium	Acid etch	Vinyl-phenolic	6743	46.5
Titanium	Acid etch	Epoxy	3183	21.8
Titanium	Liquid pickle	Epoxy	3317	22.9
Titanium	Liquid hone	Epoxy	3900	26.9
Titanium	Hydrofluoro- sulfonic acid etch	Epoxy	4005	27.6

5.1.1 Degreasing methods

Degreasing by solvent cleaning methods is used to remove soils, particularly oils, greases and waxes from the adherend surfaces. Degreasing methods do not alter physically or chemically the adherends that are cleaned, they just clean the surfaces to be joined. The degreasing methods can be classified to vapor degreasing, ultrasonic vapor degreasing, ultrasonic cleaning with liquid rinsing and solvent wiping, immersion, and spray cleaning. The degreasing methods can be used alone or as a combination of different techniques. Solvent wiping and immersion or spray cleaning are suitable for most of the metal surfaces to be pretreated. The adherend surfaces can be wiped with a cloth soaked, for example, in clean acetone. In this method, it is important to remember that the wiping materials must be clean. Wiping methods such as acetone wiping are widely used, and they remove efficiently the soil, but care must be taken to ensure that the whole surface is completely cleaned. Solvent immersion can be used for small parts to remove light soils, but for heavier soils, solvent immersion is not sufficient. For heavier soils, scrubbing by using, e.g., ultrasonic must be used. In the solvent spraying method, the solvent particles impinge the surface to be cleaned causing flow and drainage and washing away of the loosened soil. In vapor degreasing, the adherend is first washed with a suitable solvent (solvent wiping, immersion or spray) and then immersed in a suitable vaporized degreasing agent. Trichloroethylene and perchloroethylene have been widely used in vapor degreasing. In ultrasonic vapor degreasing, the parts are first cleaned either by vapor rinsing or by

immersing them in a boiling solvent. Then they are exposed to ultrasonic scrubbing, after which they are rinsed with vapor or spray plus vapor. In the beginning of the cleaning process, tests have to be carried out to select the right ultrasonic frequency and intensity for the optimum cleaning results. In ultrasonic cleaning with liquid rinsing, the ultrasonic energy scrubs the parts and the liquid solvent rinses away the loosened material. Ultrasonic cleaning with liquid rinsing needs more manual application of liquid solvents than the ultrasonic vapor degreasing. The solvent type is not much restricted, and aqueous solutions of surfactants, detergents, alkaline and acid cleaners can be used. Ultrasonic cleaning with liquid rinsing is not as efficient as the ultrasonic vapor rinsing. When different degreasing methods are used, it is important to take care of the health safety factors. The solvents might be, e.g., toxic or flammable, and therefore they must be properly handled. Nowadays there are trends to develop and use more environmentally safe and user-friendly products for pretreating the adherends [53-55].

5.1.2 Abrading methods

Abrading methods are mainly used to remove weak oxide layers, loose contaminated layers, and to roughen the surfaces. When the surface roughness increases, the effective surface area of the adhesive joint also increases. According to the mechanical interlocking theory, the adhesive will penetrate into the irregularities of the surface and form mechanical bonding. This will increase the strength of the joint. In the abrading process, there is the possibility of trapping air bubbles at the bottom of the crevices. They may then act as stress concentrators and promote the failure in rigid adhesives. The abrading methods include different kinds of mechanical treatments such as wire brushing, sanding, abrasive scrubbing, and grit blasting. In these methods, the surfaces can be abraded with a suitable abrasive cloth, a hand- or power-operated wire brush, or water abrasive paper. The most used method is the grit blasting, where the grit, i.e., the abrading media, is propelled by compressed air or by high-pressure water to the surfaces to be roughened. There are different types of grit to be used, including aluminum oxide, silicon carbide, sand, silica, silicon dioxide, quartz, and steel. The selection of the grit depends on the substrate to be abraded. The grit size and the shape of the grit particles vary. The grit should be harder than the substrate that will be treated. Sand, silicon dioxide, or silica are considered too smooth and uniform, and therefore are not recommended for blasting of metal substrates. Silicon carbide is very hard with sharp-shaped grains, and therefore it is used to blast extremely hard materials. Aluminum oxide is a frequently used blasting medium, and it is preferable for most of the metals. Aluminum oxide grains are angular in shape, and they are typically available in the size range of 16-240 grit. In the grit blasting process, it is important to ensure that the whole joining area, including the corner points where the maximum stresses will be formed, are carefully blasted. Harris and Beevers [56] studied the surface energy and adhesion characteristics of grit blasted mild steel and aluminum. They used grit blasting with different aluminum oxide grits as the pretreatment method. They noticed that coarser grits produce a rougher

surface and that these rougher surfaces have lower surface energy than the surfaces processed with finer grits. Table 1 shows that, e.g., for aluminum and cold-rolled steel the grit blasting increases strongly the shear strength values of the specimens when compared to the specimens that were only degreased. Figure 17 shows the influence of different pretreatments on the lap shear strength of aluminum adherend epoxy adhesive joints, which are aged in water at 50°C [53-56].

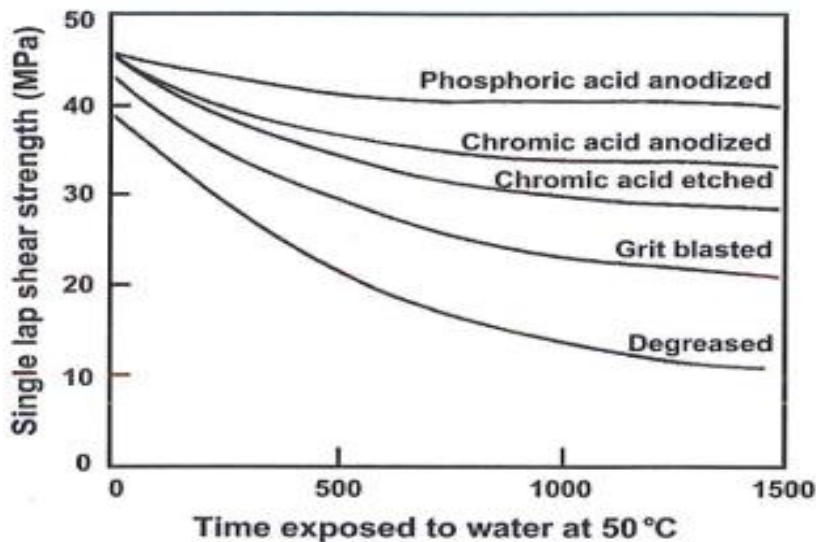

Figure 17. Lap shear strength values for aluminum alloy/epoxy joints made with different pretreatments as a function of aging time in water at 50°C [53].

Figure 17 shows that grit blasting increases the strength of the joint when compared to barely degreased specimens, but is not as efficient as the chemical methods such as etching and anodizing. When using the abrading methods, it is also important to remember to clean and degrease the surfaces properly before the blasting process. After the abrading process, the loose or loosely bonded particles have to be removed for ensuring that the surface is “clean” before the joining process. It is also good to keep in mind that the mechanical locking and increased bonded area brought about by abrading are not the only parameters affecting the joining process and wettability. Boutar et al. [57] noticed in their study on aluminum-copper alloy adherends and polyurethane adhesive that increasing roughness increases the strength and improves the wettability in the joint to a certain definite point, after which a decrease in strength and wettability is observed if the roughness of the surface is further increased. According to their results, there is an optimum roughness that gives a minimum contact angle and consequently good wettability and maximum shear strength with a cohesive fracture of the joint. Ghumatkar et al. [58] also noticed in their study of joints of aluminum or mild steel adherends and epoxy adhesive an increase of shear strength when the roughness increased to a definite value. When this value was

reached, the increase of the roughness did not increase the shear strength but instead decreased it a little bit. Brack et al. [59] noticed that the surfaces that were only polished and abraded were quite flat compared to the grit-blasted surfaces, and found that grit-blasting is the only method that markedly increases the actual surface area [53, 55-59].

5.1.3 Chemical pretreatments

Chemical pretreatments are processes that change the chemical nature of the adherend surfaces and in that way improve the adhesion. In some cases, the abrading and degreasing methods are sufficient pretreatments of adherends, but in many cases there is a need to modify also the topography and/or chemistry of the adherend surface. Especially in the cases where the joint is exposed to high humidity and temperature and maximum joint strength is required, the chemical pretreatment is preferable. For most metals, an oxide layer is formed on the surface when they are exposed to air. In many cases, this naturally formed oxide layer is weak and loosely bonded to the adherend surface. Therefore, it is often necessary to modify this natural oxide layer or to create a new, stable oxide layer for achieving a strong and environmentally resistant bond between the adhesive and the adherend. This can be obtained with different chemical pretreatments such as chemical etching and anodizing. The corrosion resistance of the adherends can also be improved by using different kinds of primers and conversion coatings [52, 54-56, 60].

Etching

For metallic adherends, acid etching or acid etching followed by acidic anodizing are widely used chemical pretreatment methods. For plastic materials, flame or plasma treatment or corona discharge methods are also used. In the etching processes, the adherend surfaces are treated with an etchant. For metal adherends, different kinds of etchants are used depending on the metal to be treated. Chromic and chromic plus sulfuric or phosphoric acids are examples of acids commonly used to pretreat metallic adherends. For aluminum and aluminum alloys, a wide range of chromic acid etching (CAE) techniques are used. Sulfuric acid-dichromate etching (FPL) has been used for a long time, and it is one of the most recognized etching pretreatments for aluminum. The FPL etching is named after its developer, the Forest Product Laboratory. The aircraft industry has widely used this method, which is also described in the ASTM D2651 standard. This process includes the steps of vapor degreasing, alkaline cleaning of the surfaces, and after that a chemical treatment with sulfuric acid-dichromate solution. Finally, the adherends are air-dried. There are different modifications of the FPL method from paste-like etching solutions to acid solutions for immersion. In different chromic-sulfuric acid treatments, the concentration of compounds, the temperatures, and immersion times vary. Nowadays the legislation

restricts the use of, e.g., hexavalent chromate containing pretreatments. This causes a need to study and replace these toxic pretreatments with environmentally more friendly alternatives. There are different types of chromate free etching processes. The chromate free sulfuric acid-ferric sulfate etchant, known as P2, has been found to be one alternative for the FPL etchant. Prolonga et al. [62] even found that the sulfuric acid – ferric sulfate pretreatment improves the joint strength of the specimens when compared with FPL pretreated specimens [62]. Saleema et al. [63] studied a sodium hydroxide (NaOH) pretreatment for aluminum alloy by immersing the aluminum substrates in an ultrasonic bath of a dilute solution of NaOH. In lap shear tests, they found completely cohesive failure for these NaOH pretreated and epoxy adhesive joined aluminum adherends when aged under cataplasma conditions at extreme humidity and temperature (temperature of 70°C and 100% relative humidity) for seven days and then exposed in a freezer to the temperature of -20°C for 16 hours [63]. In the case of ferrous metals, the used chemical pretreatments depend largely on the composition and structure of the metal. Sulfuric and hydrofluoric acids are examples of the used etchants. In the etching processes of different metals, degreasing and alkaline cleaning are typically used before the actual etching [52-56, 60-63].

Anodizing

Anodizing is an effective pretreatment for metal adherends. In this electrolytic pretreatment, the material to be pretreated works as an anode immersed in an electrolytic bath of different etchants. Chromic acid anodizing (CAA) is an effective and widely used pretreatment for, e.g., aluminum surfaces. The oxide that is formed in the CAA process on a metal adherend is moisture resistant and has good long-term durability. The CAA pretreated surfaces in adhesive joints usually give even better durability results than the FPL surfaces. Boeing Aerospace has developed the phosphoric acid anodizing (PAA) process. This method also creates a highly moisture resistant oxide layer. For aluminum, the PAA process is an optimal way to achieve durable bonds and also good corrosion resistance. Good durability has also been found for CAA plus PAA treated specimens. For aluminum, also sulfuric acid anodizing (SAA) and sulfuric boric acid anodizing treatments have been developed. Correia et al. [64] studied the influence of the sulfuric acid anodizing (SAA) and boric sulfuric acid anodizing (BSAA) treatments on the strength and durability of adhesively bonded aluminum-aluminum joints. According to them, sulfuric acid anodizing (SAA) is used especially under high humidity environments, creating a very thin oxide layer on the sample surfaces. The boric sulfuric acid anodizing (BSAA) is an alternative to the CAA treatment. Their aim was to find a suitable surface treatment and adhesive combination for adhesively bonded aluminum-aluminum joints of aeronautical structures, keeping in mind that the earlier widely used and effective chromic acid is nowadays restricted due to its danger to health. Correia et al. [64] found the (SAA) and (BSAA) pretreatments as promising alternatives for the older hazardous-to-health methods, and also that the lap shear strength values obtained with these methods

were comparable to the previously used methods. They reminded that the suitable pretreatment is also largely dependent on the used adhesive [51-56, 60, 64].

Primerizing

The adherend surfaces can also be pretreated by pre-coating them with different kinds of primers. Primers are adhesion promoters, and they have several functions in the joining process. They make the surface easily and thoroughly wettable and consequently improve the wetting. The primer coating applied on the cleaned adherend surfaces will protect the surfaces from oxidation and extend the time between the surface pretreatment and the joining process. Primers can act as corrosion inhibitors, and they can prevent the undesirable reactions between the adhesive and the adherend. Primers can modify and improve some properties of the adhesive, e.g., the peel strength. Some of the primers are able to form chemical bonds between the adhesive and adherend surfaces. These primers are called coupling agents. Coupling agents may increase the initial strength of the joint, but especially they will enhance the strength of the joint under humid conditions [6, 52, 54].

Silanes and other coupling agents are used for various substrates to build hybrid chemical bridges for increasing the strength and durability of the joint. Silane-based primers are widely used organometallic primers, but also other types of primers such as organotitanates, organozirconates, organozirconaluminates, and chrome complexes have been used. Coupling agents based on titanium or zirconium are used to improve the adhesion of filler particle surfaces or metallic substrates such as aluminum alloys. Chromium containing adhesion promoters are used in aerospace industries for the pretreatment of aluminum and its alloys. The methacrylate-chrome complexes are used in the glassfiber technology. To enhance the adhesion, it is very important that the selected coupling agents and adhesion promoters match well with the substrate and the polymeric adhesive. The pH value of the solution of the coupling agent, the solution age, and the film thickness also influence the bonding properties [6, 65, 66].

Silanes are widely used coupling agents. Silane based coupling agents have the following general structure:



where R is an organofunctional group that typically reacts with the adhesive, and R' is a hydrolyzable group, typically an ethyl or methyl group. Silicon is the central component of these silane-based molecules. Silanes are organofunctional compounds possessing a dual reactivity. They consist of short organic chains, which have different chemical composition at either end of the chain. One of the ends is

capable of reacting with the polymers in the adhesive, while the other end can react with inorganic substrates such as metals and metal oxides. Silanes improve the durability of the adhesive joints in both wet and dry environments, but especially they are effective in wet environments. Typically, they are applied to the adherend surfaces from dilute aqueous solution. As primers, the silanes can be applied on the adherend surfaces by wiping, spraying, brushing, or dipping. The market for the adhesion promoters has grown strongly in the past few decades, and there is a large selection of silanes commercially available. Table 2 shows some typical commercially available silane adhesion promoters [6, 64-65, 67].

Table 2. Typical silane adhesion promoters [65].

Chemical description	Structure	Functional group	
		With polymer	With substrate
3-Chloropropyltrimethyl oxysilane	$\text{ClCH}_2\text{CH}_2\text{CH}_2\text{Si}(\text{OCH}_3)_3$	Chloro	Methoxy
Vinyltriethoxysilane	$\text{CH}_2=\text{CHSi}(\text{OC}_2\text{H}_5)_3$	Vinyl	Ethoxy
γ -Methylacryloxypropyl trimethoxysilane	$\begin{array}{c} \text{CH}_3 \quad \text{O} \\ \quad \\ \text{CH}_2=\text{C}-\text{C}-\text{OCH}_2\text{CH}_2\text{CH}_2\text{Si}(\text{OCH}_3)_3 \end{array}$	Methacryloxy	Methoxy
γ -Glycidoxypropyl trimethoxysilane	$\begin{array}{c} \text{CH}_2\text{CHCH}_2\text{OCH}_2\text{CH}_2\text{CH}_2\text{Si}(\text{OCH}_3)_3 \\ \\ \text{O} \end{array}$	Aliphatic epoxide	Methoxy
γ -Mercaptopropyl trimethoxysilane	$\text{HSCH}_2\text{CH}_2\text{CH}_2\text{Si}(\text{OCH}_3)_3$	Mercapto	Methoxy
γ -Aminopropyltriethoxy silane	$\text{NH}_2\text{CH}_2\text{CH}_2\text{CH}_2\text{Si}(\text{OC}_2\text{H}_5)_3$	Amino	Ethoxy
N- β -(Aminoethyl) aminopropyl trimethoxysilane	$\text{NH}_2\text{CH}_2\text{CH}_2\text{NHCH}_2\text{CH}_2\text{CH}_2\text{Si}(\text{OCH}_3)_3$	Aminodiamino	Methoxy

Table 2 shows only a part of the silanes that are commercially available, and new formulas are continuously coming to the market. The selection of a particular silane depends on both the adhesive and the adherend types. One of the most commonly studied organosilanes for promoting the adhesion on metal surfaces is the γ -glycidoxypropyltrimethoxysilane (GPS), the structure of which is shown in Table 2 and in more details in Figure 18.

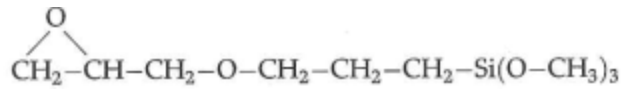

Figure 18. Structure of γ -glycidoxypropyltrimetoxysilane (GPS) [54].

The (GPS) silane has been studied especially as an adhesive promoter for aluminum adherends. Rider et al. [68] studied the factors influencing the durability of epoxy adhesion to silane-pretreated aluminum. They noticed that the γ -GPS treatment of roughened aluminum adherend surfaces improved the durability of wedge test specimens. However, the initial surface roughness of aluminum also affected the overall bond durability. Johnson et al. [69] studied the joint durability of pretreated aluminum alloy AA6060 in a hydrothermal environment using the wedge test. According to the test results, the pretreatment of the surfaces with a 1% aqueous solution of γ -GPS improved remarkably the joint durability in the case of differently pretreated surfaces. As a pretreatment, they studied abrasion, grit blasting, FPL etching, and sulphuric acid anodizing. They also noticed that the initial crack length in the wedge test specimens was reduced. The highest durability was obtained for the specimens with grit blasting plus silane pretreatment. The durability of these specimens was higher than that of the FPL-pretreated specimens. Brack et al. [59] noticed in their study that while the grit blasting increases the fracture toughness of adhesive bonds of titanium at short aging times, the silane pretreatment together with mechanical roughening retard the decrease of the fracture toughness for longer aging periods. In addition, they found that the fracture toughness is higher for γ -GPS treated specimens in humid environments. They also reminded of the possibility of the organosilane film to become unstable in humid environments, if the critical concentration of moisture is exceeded [59, 68-69].

When the silanes are applied on inorganic adherend surfaces, such as metals, glasses etc., different reactions will take place, as shown in Figure 19. First, in step 1, the hydrolyzable group R' in the silanol chemical formula hydrolyzes in the presence of water to trisilanol $-\text{Si}(\text{OH})_3$. In step 2, the silanols that are very reactive, will rapidly react through a condensation mechanism with hydroxyl OH groups present on the adherend surface. The formed polysiloxane network is covalently bonded to the surface. A continuous chain of strong covalent bonds will be formed from the substrate through the adhesive. The presence of water at the interfaces is necessary for the hydrolysis reaction of organosilanes to occur for bonding to the adherends [54, 67, 70].

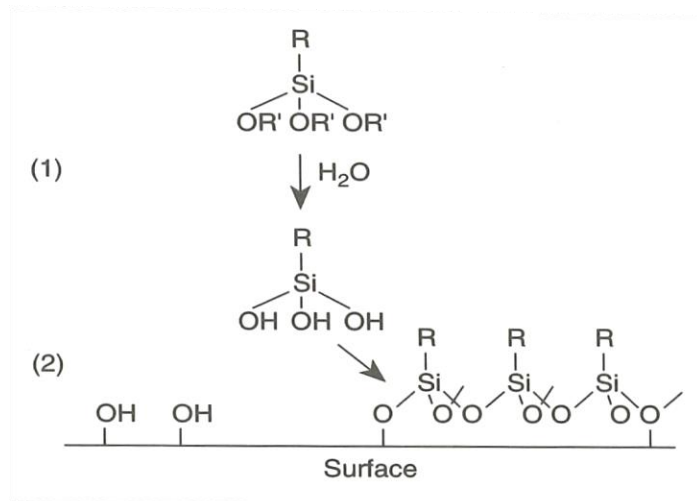

Figure 19. Reactions during the attachment of silane to an inorganic surface [54].

In general, when metal adherends are pretreated, the forming bonds are due to polar interactions that are easily broken by water molecules. The silanes, instead, produce strong chemical bonds that water cannot break, and therefore the resulting adhesion measured under wet conditions does not differ markedly from the adhesion measured under dry conditions [71]. The polysiloxane films that are formed on inorganic metal and ceramic surfaces are dependent on the silane solution and the application parameters such as the solution pH, silane concentration, nature of the solvent, hydrolysis time, drying temperature, and the time between the silane application and bonding. Abel et al. [72] studied the durability of epoxy adhesive-aluminum adherend joints when the surfaces were pretreated with γ -GPS. They used the Boeing wedge joint test according to the standard ASTM D 3762-79. In the beginning, they compared the 1% silane solution with pH 5 to the other chemical and mechanical pretreatment methods. The wedge test results of these tests are shown in Figure 20.

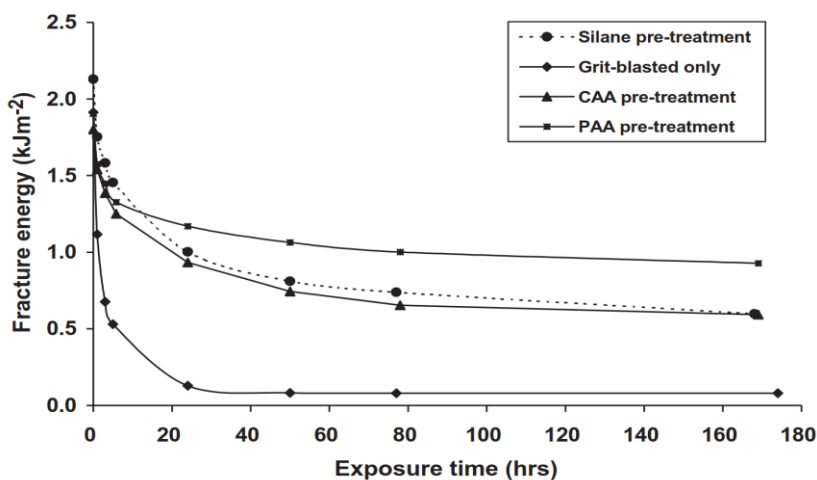

Figure 20. Wedge test results for differently pretreated aluminum adherend – epoxy adhesive joints [72].

Figure 20 shows that the silane pretreatment is more effective than grit blasting and at quite the same level as the CAA pretreatment in enhancing the durability of the joint in the wedge test. Abel et al. [72] found that the pH of the organosilane solution has an influence on the durability of the joint. In their study, they used a silane solution with a pH value varying from 3.0 to 11.0. The pH value of the silane solution is believed to control both the hydrolysis and condensation reactions of the silane solution in the joint. Alkoxy silanes hydrolyze more rapidly under mildly acidic conditions. The condensation tends to be more rapid when the pH exceeds the value of 7. The high level of condensation may have detrimental effects on the adhesion promoting capability. High level of condensation eliminates the silanol groups, which would promote the surface oxide hydroxyls to form covalent bonds. The best results were obtained when the pH value of the silane solution was 5. Abel et al. [72] also studied the influence of silane concentration, the used solvent, the solution hydrolysis time, and the drying temperature on the durability of the joint. Low concentrations were found to be the best, as they are thought to minimize the contacts of neighboring silanetriol molecules and consequent condensation reactions. In the work of Abel et al. [72], the 1% concentration was found to give the best results. The solution hydrolysis time of one hour was found to be the best, while the drying temperatures of 23°C or 93°C did not seem to have an influence on the results. They also found that the time between the silane pretreatment and the formation of the bond had little or no influence on the bond durability up to seven days. When the processing time increased to over seven days, the durability was lowered [72]. Pantoja et al. [73] studied the influence of silane pretreatments on the adhesive joint properties, when the adherend was an electrogalvanized steel and the adhesive was a single component urethane-methacrylate anaerobic adhesive. In their study, they used a 1% silane solution with two different pH values of 4 and 6. They found that the pH 4 silane solution gives better adhesion properties than the pH 6 solution. The pH 4 solution produces thinner and more homogenous coatings. The failure mode of the joint was cohesive when the pH value was 4, but when the pH value was 6, the failure mode was highly adhesive. The shear strength of the joint pretreated with the pH 4 silane solution as a function of the hydrolysis time was also higher than that of the joint pretreated with the pH 6 silane solution. Hydrolysis times up to four days did not seem to affect the shear strength values of single lap joint specimens [72, 73].

Laser treatment

Laser treatment is an environmentally friendly and efficient pretreatment for metallic surfaces such as aluminum and titanium. The chemical “wet” pretreatments such as phosphoric acid anodizing (PAA), chromic acid anodizing (CAA), and pickle etching are efficient pretreatment methods for building a strong and durable joint between the adhesive and the adherend. These “wet” pretreatments, however, have several disadvantages, such as long pretreatment times, ecological disadvantages such as disposal of chemicals and wastewater, pretreatment of the whole surface of the part

when only a small area of the part will be bonded, and so forth. To avoid these disadvantages of “wet” pretreatments, laser pretreatments have been developed. Ciba developed and patented the Ciba laser pretreatment, CLP, to form strong and durable adhesive joints [74]. The CLP process consists of two steps: primer application and laser pretreatment. The laser type and the treatment parameters depend on the substrate and the production requirements. With the CLP process using a high performance laser, it is easily possible to pretreat an area with a width of 4 cm at a speed of 8 m/min. When the CLP pretreatment has been used, the failure type of the joint has been fully cohesive before and after the aging process. Figure 20 shows the lap shear strength values of differently pretreated adhesive joints, when aged under cataplasma conditions [74].

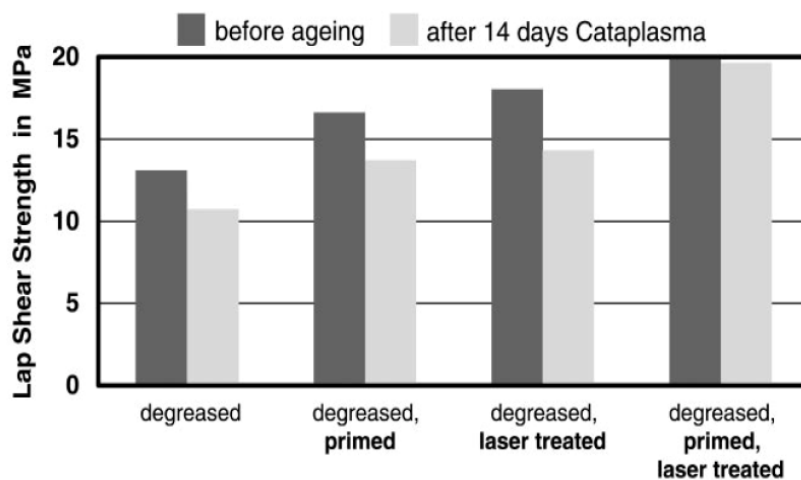

Figure 21. Influence of the pretreatment method on the lap shear strength values of aluminum alloy substrates joined with 2-component epoxy adhesive before and after aging [74].

Figure 21 shows that the primer or laser pretreatment alone increases the strength of the joint when compared to bare degreasing as the pretreatment. The joint failure is still of adhesive type. The combination of primer application and laser pretreatment gives fully cohesive failure and higher strength than the other pretreatment methods. Figure 22 shows the time to failure for differently pretreated adherends under 100% relative humidity and a mechanical load of 5 MPa at the temperature of 42 - 48°C. The CLP pretreated surfaces have the durability up to 1500 days [74].

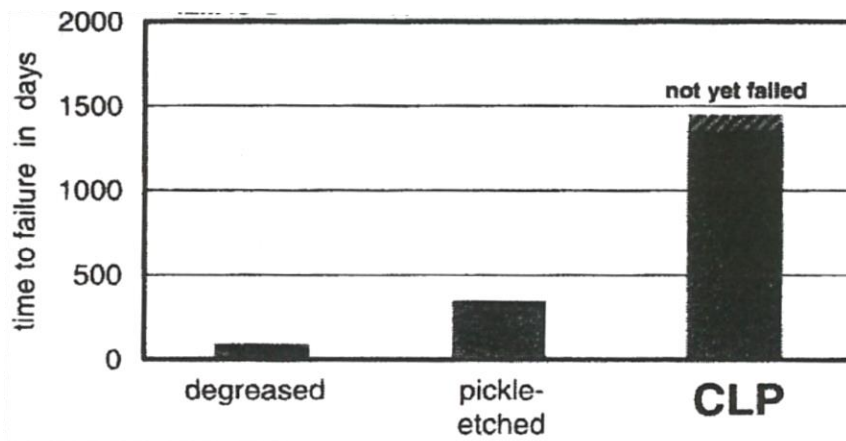

Figure 22. Time to failure for differently pretreated aluminum joints bonded with one-component epoxy adhesive under the aging conditions of 100% relative humidity, 5 MPa load, and temperature of 42-48°C [74].

The use of CLP as a pretreatment method is not restricted to aluminum and aluminum alloys. It is also suitable for other metals, including stainless steel and titanium. The primers that are used with CLP for aluminum can be, e.g., organosilanes, organotitanates, zirconates, and zircoaluminates [75, 76]. The metal surface can be pretreated with the organosilane either before or after the laser pretreatment. According to patent WO 96/23037, it is preferable to first apply the organosilane to the metal surface and after that expose the surface to the laser treatment. According to the same patent, any laser that can produce a sufficient temperature on the metal surface can be used. Such lasers are, e.g., gas lasers, excimer lasers, CO₂ lasers, and Nd-YAG (Neodymium – doped yttrium aluminum garnet) lasers. The used power level is dependent on the metal surface. According to the patent, the adherend surface is suitable for adhesive joining at least three days after the laser treatment [75]. In both patents WO 96/23037 and WO 99/37830 [75, 76], the possibility of using an unfocused laser has been mentioned as an advantage of the laser treatment. The use of an unfocused laser may limit the damage to the adherend surface.

A metallic adherend, which is subjected to short time melting and cooling by a laser pretreatment, develops a dendritic structure on its surface. The laser pretreatment has to be carried out above a material-dependent threshold power value for obtaining the ablation. Rechner et al. [77] analyzed the interaction between laser irradiation and material surface by studying the influence of the treatment on the topography and chemical composition of the aluminum surface. They used SEM-EDX, FTIR spectroscopy, and XPS methods for the characterization of pretreated surfaces. They compared the laser pretreatment with the “wet” chemical pretreatment and the atmospheric pressure plasma (AP) pretreatment. According to their results, the laser pretreatment improves the cleaning of the surfaces and modifies the oxide layer. It is assumed that a thermal oxide layer will be formed when there is an increased oxygen

content during the laser interaction with the material. The oxygen content of the aluminum surface increases when the laser intensity increases. Due to the treatment, the tensile shear strength of the pretreated joints increases before and after aging. No clear connection was found between the increased shear strength and the oxidation layer. The laser parameters that give the highest shear strength values also generate a heavily structured surface [77]. Spadaro et al. [78] studied the influence of laser pretreatment parameters on the resulting adhesion properties. They exposed the aluminum alloy adherends to Nd-YAG laser irradiation with varying beam diameter and energy density. They used the laser irradiation as the only pretreatment for removing the contamination and for modifying the chemical composition and morphology of the adherend surface. They found that the laser parameters have an influence on the durability of the joint. When comparing the laser pretreatment to degreasing, abrasion, and chemical methods, they noticed that the failure becomes mainly cohesive only after chemical etching or laser pretreatment [78]. Baburaj et al. [79] used the laser treatment for titanium surfaces to be adhesively joined. They found that the laser treatment increases the strength of the adhesively joined structure. The strength is believed to increase due to the chemical changes on the adherend surface, caused by the formation of microcones, and an increase in the actual surface area of the adherend [79].

During the past few years, the pulsed laser ablation (PLA) has been intensively studied as a pretreatment of metal surfaces for improving the adhesion properties. Several researchers have used the ablation process to clean the surfaces, to modify the surface morphology and chemistry, and to increase the strength and durability of the adhesive joint [80, 81, 82]. Rotella et al. [81] studied the influence of fiber laser pretreatment on the surface morphology of the adherend and on the joint strength in steel/epoxy joints. They used a pulsed ytterbium-doped fiber laser system. They varied the average power, laser speed, and pulse frequency to obtain nine different values for the pulse fluence F (J/cm^2). When analyzing the treated surfaces of the adherends with SEM, they noticed that for the DP500 steel the laser pretreatment at a lower power level rather cleaned the surfaces than caused marked morphological modifications. They also noticed that the static strength (T-peel and shear strength values) of the laser pretreated joints increased both before and after the exposure to an aggressive environment when compared to only degreased and sandblasted specimens. SEM studies of the fracture surfaces of the laser-pretreated joints showed that the failure was of an interfacial, cohesive type. Chiodo et al. [82] studied the influence of laser ablation on the aluminum alloy AA6082-T4 adherend surfaces using an ytterbium pulsed fiber laser. They used surface profilometry, SEM, and XPS analysis for characterizing the surface morphology and chemistry. The laser pretreatment produced chemical and morphological modifications and strengthened the mechanical interlocking. In the mechanical tests, a 20% increase in the shear strength was obtained for the laser-pretreated specimens when compared to barely degreased specimens [82].

Plasma treatment

Plasma pretreatment is mostly used for polymeric adherends, but to some extent it is also used to metal adherends. Plasma (glow discharge) is produced by exciting a gas with electrical energy. The electrically conductive plasma gas consists of excited atoms, ions, and free radicals. For titanium alloys, both the glow discharge and plasma spraying have been used as surface pretreatment methods. The glow discharge for titanium adherends has been used for obtaining a clean and modified uniform oxide structure on the surfaces. High bond strength and durability of the joints have been obtained also with the plasma treatment called sputtering [2,50]. Mandolino et al. [83] studied the influence of both laser and plasma pretreatments on the mechanical properties of adhesively bonded joints of Al 6061-T6. They used argon and helium as plasma gases, and the treatment was carried out in a radio frequency (RF) low pressure plasma. The power was in the range of 10-200 W. They produced single-lap specimens and used them in shear tests. When comparing the test results of differently pretreated specimens, they noticed that the laser-pretreated specimens had the highest shear strength values. Plasma pretreated specimens had strength values slightly higher than the acetone cleaned specimens. In plasma pretreatment, the strength of the joint increases when the power or the pretreatment time increases, or the treatment gas is changed from argon to oxygen. In laser-pretreated specimens, the strength is also dependent on the used process parameters. [83] Saleema et al. [84] studied the lap shear strength of aluminum adherend – epoxy adhesive joints pretreated with the atmospheric pressure helium-oxygen plasma process in a pristine condition and by exposing them to extreme humidity and temperature (cataplasma) conditions. The used oxygen plasma pretreatment was carried out under ambient atmospheric conditions. They carried out microstructural and chemical analyses of the pretreated surfaces with different techniques and noticed that the plasma exposure time influenced the chemical characteristics of the surface. In the lap shear tests, the adhesion strength values were also dependent on the plasma exposure time. High adhesion strength values of about 24 MPa were measured for oxygen plasma pretreated surfaces, and the failure type was cohesive. After aging under cataplasma conditions (at the temperature of 70°C and 100%RH for seven days and at the temperature of -20°C for 16h), the remaining strength values were very low, only about 4 MPa for the shear strength. When using the Scotch Brite pretreatment prior to plasma exposure, the adhesion strength values stayed high at about 22 MPa during aging, and the fracture type was cohesive [84].

5.2 Joint protection

In general, the metal adhesive joint is hidden from environmental factors such as UV-radiation, and the harmful influence of the radiation to the adhesive itself and the adhesive joint is then prevented. Moisture is one of the most detrimental factors in decreasing the durability of the joint. To increase the durability and aging resistance of the adhesive joint, it is important to prevent water from entering to joint. Mechanical loading, especially the loading type together with the environmental factors such as moisture, temperature, radiation, etc., affects strongly the durability of the adhesive joint. One way to improve the durability against these aging factors is to design the joint geometrically in an optimal way so that the loading type is correct and water may not easily enter the joint. The penetration of water into the joint can also be prevented or decreased by sealing the joint with some barrier coating that is impermeable to water. The joint edges can be protected with a water-resistant coating, or the whole joint can be enclosed from the environment to prevent water from entering the joint [85]. There are also mixed adhesives that will give better resistance against environmental aging factors. Some of these dual type adhesives can be used under extreme conditions such as high temperatures, extremely moist environments, and heavy loads.

6. AIM OF THE WORK

In this thesis, the effect of static loading together with the environmental aging factors (temperature and humidity) on the long-term durability of adhesive metal joints is studied. Studies on the effects of the environmental factors such as temperature and humidity on the durability of adhesive joints can be found in the literature. There are also studies on the effects of loading on the durability of adhesive joints. No extensive studies on the combined effects of environmental factors and static loading on the durability of adhesive joints are, however, available. Therefore, this study aims to clarify the combined effects of environmental aging and static loading on adhesive joint durability.

Previous studies at TUT have suggested the possibility for the existence of a threshold stress, a specific level of external loading above which the strength of the aging joint is lost rapidly, while only a small reduction of strength with time occurs under similar aging conditions without the loading stress. One aim of this thesis is to verify the existence of the threshold stress value under different aging conditions. The influence of different pretreatment methods on the long-term durability and the level of the eventual threshold stress will also be explored. The fracture surfaces of aged and tested adhesive joints are studied to reveal the type of fracture (cohesive or adhesive) and its evolution during the aging process.

7. EXPERIMENTAL METHODS

In this study, an aluminum alloy was used as an adherend material and an epoxy type adhesive as the joining medium for the preparation of single lap joint specimens. The adhesive joints were exposed to different aging conditions (different relative humidity and temperature values) to reveal the influence of aging conditions on the strength evolution of the adhesive joint. The specimens were stressed to different levels of static loading during the aging exposure, and the combined effect of the loading levels and aging conditions on the evolution of the strength of the adhesive joint was studied. The influence of the pretreatment methods of the adherend surfaces on the joint durability was also studied.

7.1. Studied materials and adhesives

The focus of this study was on the structural adhesive joining of aluminum. Aluminum is one of the most widely used metallic adherend materials for structural adhesive bonding due to its several advantages, including the high strength-to-weight ratio, excellent corrosion resistance in most environments, and low cost. Nowadays there is a strong tendency for light-weight structures, and aluminum is a potential material for them. Structural adhesive joining of aluminum is typically used in aerospace, automotive, and mechanical engineering as well as in the building industry.

Aluminum alloy Al 6082- T6 was used as the adherend material. This alloy belongs to the 6000 -series of aluminum alloys, and it is consequently alloyed with magnesium and silicon. It is a structural alloy having medium to high strength and excellent corrosion resistance. It is widely used in highly stressed applications, bridges, transport applications, machine building, offshore constructions, etc.

Epoxy adhesives are nowadays widely used for the structural joining of metals. Epoxies have good wetting properties of most surfaces, and the durability and strength of the epoxy adhesive joints are high. In this work, Araldite 2014 (a/b) epoxy adhesive from Huntsman was used. It is a two-component room temperature curing adhesive having a high strength. It has high resistance to water and good resistance to a variety of chemicals. It is used to bond metals, electronic components, GRP structures, and many other materials/structures when the joint is exposed to elevated temperatures and/or aggressive environments. Araldite 2014 (a/b) is heat resistant up to 120°C and it can be used to bond many kinds of materials. Its T_g temperature ranges from 85°C up to 110°C, depending on the curing conditions. The pot life of this adhesive at room temperature (25°) is 60 minutes. Open time in the gluing process was at maximum 30 minutes. The minimum curing time that the supplier recommends for room temperature curing is six hours. The storage time for Araldite 2014 at temperatures from 15°C to 25°C is one year [86].

In the chemical pretreatments of the adherends, Dynasylan GLYMO 3- glycidol-oxypopyltrimethoxysilane was used [87-88]. It is a bifunctional organosilane containing reactive organic epoxide and hydrolysable inorganic methoxysilyl groups. This dual nature of reactivity enables the formation of strong bonds with both inorganic materials such as metals and with organic polymers such as adhesives. The silane primer solution was prepared by mixing the methoxypropanol solution, water, acetic acid, and silane exactly in the amounts the silane producer recommended. The solution was homogenized by magnetic mixing and the hydrolysis time was one hour. The pH value of the solution containing 1% of silane was 5.

7.2. Preparation of test specimens

A 6082 (6082-T6) aluminum alloy sheet was waterjet cut for the preparation of single lap joint specimens according to the ASTM D 1002 standard. Water cutting was used to avoid the distortion of specimens caused by the cutting process. The thickness of the aluminum sheet was 2.0 mm. Figure 23 shows the dimensions and the shape of the test specimen. The specimens were slightly shorter and thicker than in the standard, but these changes helped to maintain the stresses in pure shear mode during loading and testing.

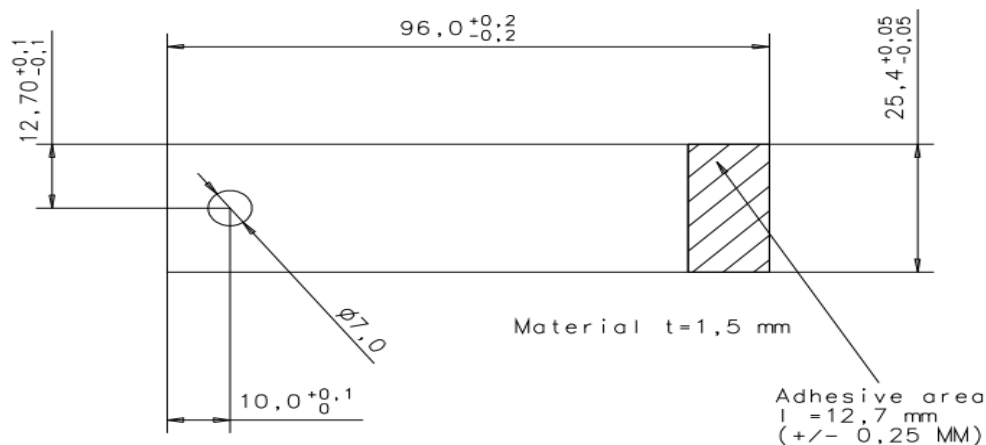

Figure 23. Dimensions and geometry of the test specimens.

The overlap length of the specimen joint was 12.7 ± 0.25 mm, and the width of the specimen was 25.4 mm. The holes at the ends of the specimens used for fixing the specimen to the loading rig were at the distance of 10 mm (the center of the hole) from the end of the specimen, as defined in the ASTM D 2919 standard [89-90].

The joint surfaces of the specimens were either mechanically or mechanically plus chemically pretreated. The mechanically pretreated surfaces were sand blasted and acetone degreased. Aluminum oxide sand with the average particle size of 300-600 μm was used as the sand blasting medium. Part of the mechanically pretreated and bonded specimens were protected at the edges of the joints with silicone to minimize the influence of humidity on the joint. The chemical pretreatment was carried out with the silane solution. The silane pretreated specimens were first mechanically pretreated by Al_2O_3 sand blasting and acetone degreasing before the silane pretreatment. In the silane pretreatment, the specimens were dipped to the silane solution of 3-glycididloxypropyltrimethoxysilane (Dynasylan Glymo) for a few minutes, after which the silane layer was dried for 24h at room temperature before joining the specimens with the adhesive.

After specimen pretreatments, the adhesive Araldite 2014 (a/b) used in this study was prepared by mixing the components a and b with the proper mixing ratio (100:50) at room temperature. After that, the adhesive joints were prepared by applying the adhesive with spatula on the pretreated surfaces of the specimens. The joints were cured at the temperature of 22°C for at least one week before the aging tests. The joints were slightly pressed during the curing process to ensure the spreading of the adhesive over the entire adhesive joint area and the formation of a homogeneous and durable adhesive joint. The bonding process was similar for all specimens prepared in this work.

7.3. Aging exposures

The joined single lap specimens were stored at room temperature at least for one week before the aging exposure. In the aging exposure, the specimens were aged in weathering cabinets where the temperature and humidity of the atmosphere could be controlled. During the aging process, the joints were exposed to different levels of static loading at the temperature of either 60°C or 70°C and at the constant relative humidity of either 75%RH or 85%RH for different times. The static loading of the single lap joints was carried out by using the test rig shown in Figure 24.



Figure 24. Test rig used for the static loading of the single lap joint specimens during the aging exposure.

The test rig shown in Figure 24 applies the loading in the way specified in the standard ASTM D 2919. The adhesive single lap joint of the specimen is stressed in shear by compressing the spring of the test rig. The load level can be adjusted by the compressing length, when the spring constant of the loading spring is known. The spring constants were measured in compression by using the universal materials testing machine Instron 8801 (or MTS-810). During loading of the specimens, the compression of the spring corresponding to the aimed load was measured with a slide gauge with the accuracy of ± 0.02 mm, corresponding to an about 1% deviation in the load (less than 10N). Five specimens can be tested at the same time in one loading rig, and six similar rigs were used simultaneously in the aging tests.

During aging, the single lap joints were loaded to the stress levels of 5%, 10% and 15% of the initial strength of the joint. For each test point in the aging tests, five specimens were used and the test result was calculated as the average of these five measurements. Unstressed specimens were also exposed to the aging conditions of either 60°C or 70°C and the humidity of either 75% RH or 85% RH to be used as references for the merely sand blasted specimens. The tests were also carried out

with loaded specimens under ambient laboratory conditions to compare these results with the results obtained under the above mentioned aging conditions.

7.4. Testing of aged joints

Before the aging tests, the initial strength of the single lap joint specimens was measured with tensile tests for both types of samples (i.e., sandblasted and sandblasted + silane-treated) to be subjected to aging. The tensile tests were carried out by using the universal materials testing machine Instron 8801 or MTS 810. The specimens were fixed carefully to the grips and aligned well to avoid the bending and skew loading of the specimen. The crosshead speed in the tests was 1mm/min. After aging, the specimens were let to stabilize/dry at room temperature for at least one day before mechanically testing them. The maximum time between the end of the aging treatment and the mechanical tests was seven days. The residual strength of the joints after aging with different static loading levels was measured as a function of aging time.

7.5. Characterization of tested joints

The fracture surfaces of the specimens were visually studied after the aging tests for revealing the fracture type of the specimens. All specimens were visually inspected to characterize the main type of fracture (cohesive or adhesive). The influence of the aging conditions on the fracture type was evaluated as described in the results section 8.2. Part of the fracture surfaces were photographed for later inspection.

8. RESULTS

The strength of the single lap specimens was measured as a function of the aging time after being aged under different conditions with different static loadings. The strength of the joint was also measured after aging exposure without loading. The strength of the specimens loaded statically at ambient laboratory conditions for the selected aging times was also measured.

8.1. Development of strength as a function of aging time

Before the aging tests, the initial strength of the single lap adhesive joint was measured for each type of specimens subjected to aging, as explained in Chapter 7.4. The initial strength as well as the strength of the specimens aged under stress or non-stressed were determined using Equation 9 presented in Chapter 3. The initial strength of the sand blasted specimens is shown in Figure 25. The average value of strength of the only sand blasted specimens was 17.88 MPa, and the maximum deviation of the individual strength values from the average value was 1.52 MPa.

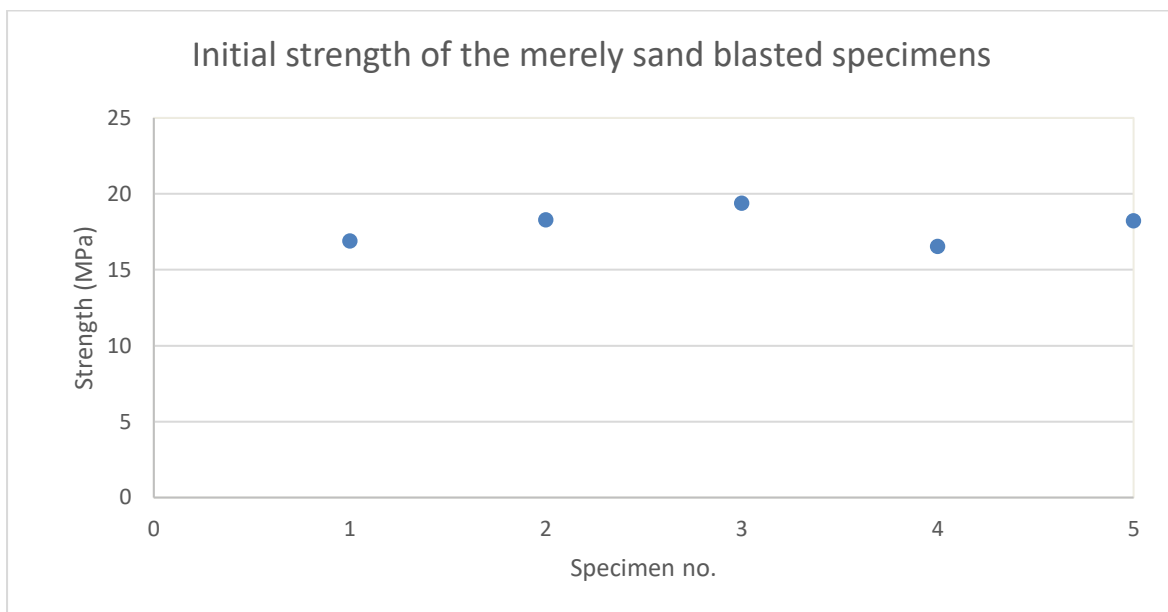

Figure 25. Initial strength of the merely sand blasted specimens as averages of five similarly prepared samples.

Figure 26, in turn, shows the initial strength values for the five similarly prepared sand blasted and silane pretreated specimens. The average value of the initial strength of

these samples was 16.74 MPa, and the maximum deviation of the individual strength values from the average value was 0.93 MPa.

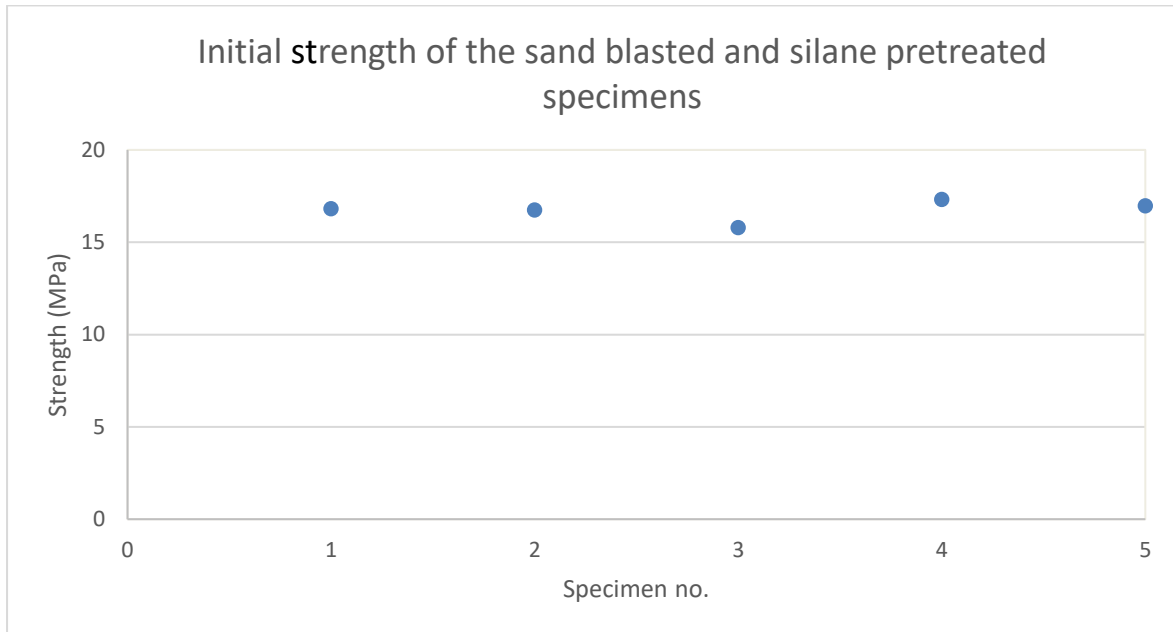

Figure 26. Initial strength of the sand blasted and silane pretreated specimens as averages of five similarly prepared samples.

The strength of the aged specimens was measured after 1, 3, 7, 21 and 42 days of exposure in the aging environment at different stress levels. The relative residual strength values of the aged and stressed specimens were determined as the percentage of the initial strength, i.e.,:

$$\tau_{res}(\%) = \frac{\tau_f}{\tau_0} \quad (17)$$

where τ_{res} is the relative residual strength, τ_f is the strength of the aged and stressed specimens, and τ_0 is the initial strength of the joint. Examples of the residual strength values of the aged and stressed specimens as a function of aging time are shown in Figures 27 and 28 for the two different pretreatments of the joint surfaces. More aging test results will be presented in Chapter 9.

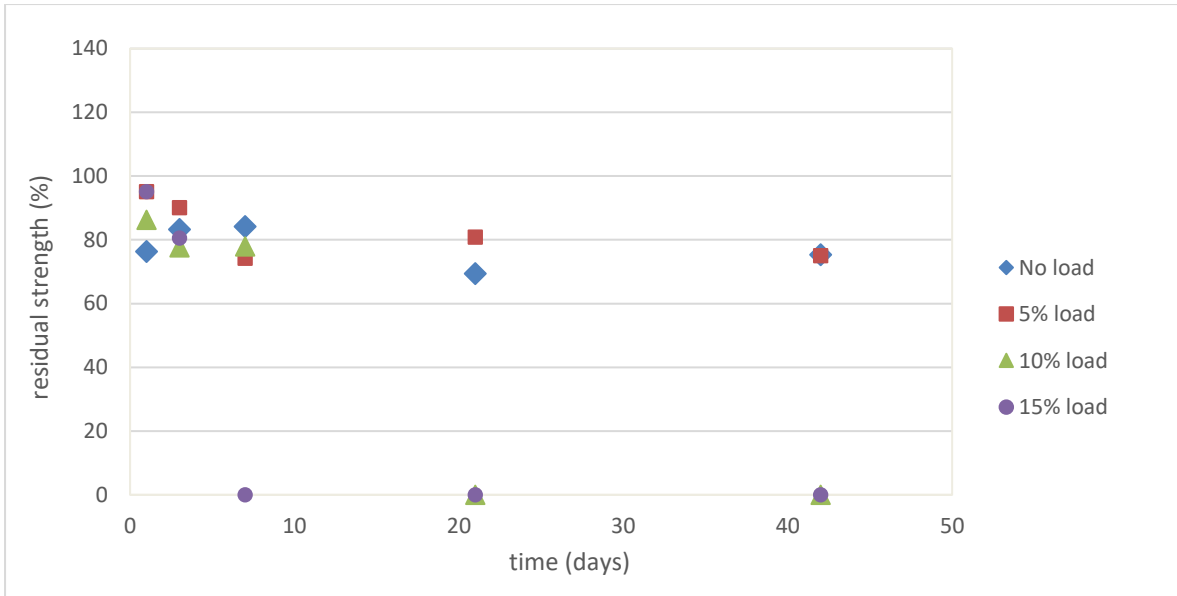

Figure 27. Residual strength of the merely sand blasted specimens as a function of time after aging at 60°C and 75% RH at different stress levels.

Figure 27 shows that the strength of the merely sand blasted specimens tends to decrease under the aging conditions, when compared to the initial strength of the joint. There is some typical scatter in the joint strength but the trend appears to be quite clear. Increasing load level to 10% and 15% decreases the strength and durability of the joint more rapidly.

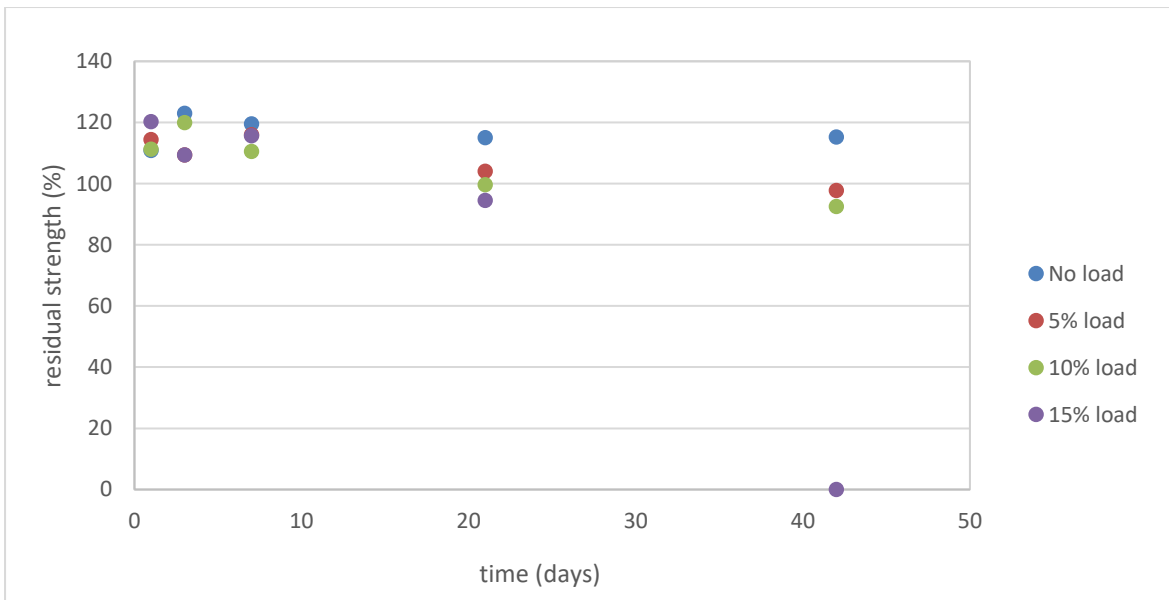

Figure 28. Residual strength of the sand blasted and silane pretreated specimens as a function of aging time at 60°C and 75% RH at different stress levels.

Figure 28 shows that in some cases, especially for the silane treated specimens, the strength of the adhesively joined specimens increases in the beginning of aging. After longer aging periods, however, the strength values typically decrease. In the first stages of the aging process, it seems that the temperature rise may reactivate the polymerization process and strengthens the joint, especially for the silane-pretreated specimens at the lower loading levels. Figures 27 and 28 show that the silane pretreatment together with sand blasting gives better strength and durability for the joint when compared to the merely sand blasted specimens. Table 3 shows all combinations of the aging conditions and loading levels used in the testing of specimens pretreated by different methods.

Table 3. Combinations of the aging tests on specimens pretreated with different methods before adhesive joining. The aging times for all test combinations were 1, 3, 7, 21 and 42 days.

Aging tests	
aging condition and pretreatment method	loading level
60°C, 75RH, silane	0, 5, 10, 15%
60°C, 75RH, sand blasted	0, 5, 10, 15%
60°C, 75RH, sand blasted + silicone protection	0, 5, 10, 15%
70°C, 75RH, silane	0, 5, 10, 15%
70°C, 75RH, sand blasted	0, 5, 10, 15%
60°C, 85RH, silane	0, 5, 10, 15%
60°C, 85RH, sand blasted	0, 5, 10, 15%
70°C, 85RH, silane	0, 5, 10, 15%
70°C, 85RH, sand blasted	0, 5, 10, 15%
RT, sand blasted	0, 5, 10, 15%

8.2. Evolution of the fracture characteristics during aging

The fracture surfaces of the specimens aged under a constant tensile stress were visually studied after the tensile tests to reveal the main fracture type of the joint. The fractions of the cohesive and/or adhesive types of fracture were estimated from the fracture surfaces. The influence of temperature and humidity on the fracture type was studied, and the effects of stress combined with these two aging factors on the fracture type were also explored. The influence of the pretreatment method on the evolution of the fracture type during aging was revealed by these characterizations.

Before the aging tests, reference specimens were produced and mechanically tested without aging to evaluate the fracture type and the strength of the non-aged and non-

stressed specimens. Figure 30 shows the fracture surfaces of the merely sand blasted specimens (Fig. 30 a) and of the sand blasted and silane pretreated specimens (Fig. 30 b).

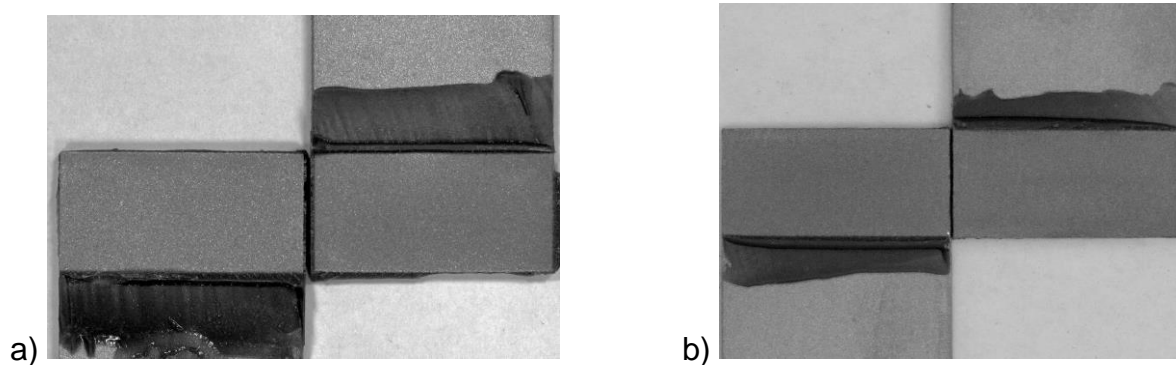

Figure 30. Fracture surfaces of the non-aged and non-stressed specimens for different pretreatment methods: a) mere sand blasting b) sand blasting plus silane pretreatment.

As Figure 30 shows, the joint fracture in both merely sand blasted and sand blasted plus silane-pretreated specimens was approximately 100% of cohesive type. Figure 31, in turn, shows the fracture surfaces of the merely sand blasted specimens when tensile tested after stressing in dry conditions at room temperature for 6 weeks at the stressing level of 10% (a), and for 6 weeks at the stressing level of 15% (b). The test results of the specimens stressed at RT under dry conditions show that the failure type is still approximately 100% cohesive and independent of the loading level. During the aging of stressed specimens at elevated temperature and humidity conditions, an increasing fraction of adhesive type fracture was typically seen with increasing aging time and stress level.

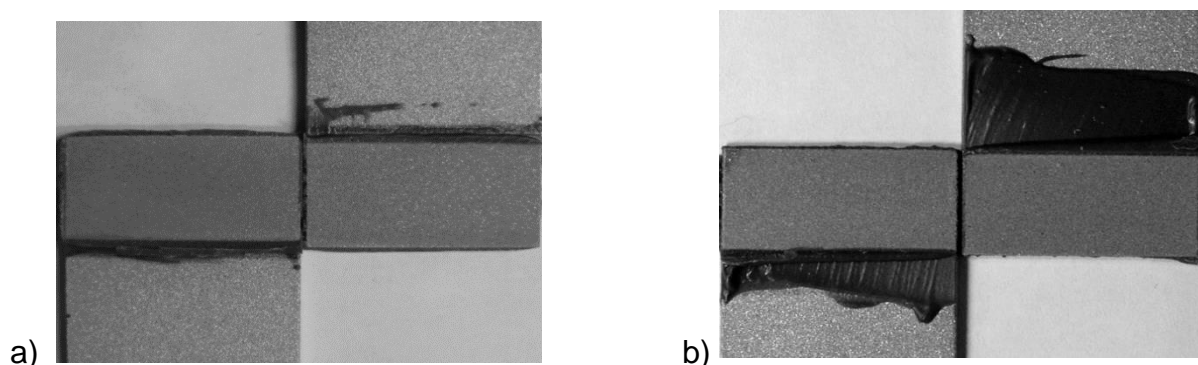

Figure 31. Fracture surfaces of the merely sand blasted specimens after stressing for 6 weeks under dry conditions at room temperature with a) 10% stressing level b) 15% stressing level.

When aging the stressed specimens at higher temperatures and humidity levels, an increasing fraction of adhesive type of fracture was seen with increasing aging time and stress level. Figure 32 shows typical fracture surfaces of the sand blasted and silane pretreated specimens, when aged at 60°C and 75% RH at the stressing level of 15% for seven days (Fig. 32 a) and for three weeks (Fig. 32 b). As seen from Figure 32 a, after one week of aging the fracture is approximately 90% of cohesive type. After three weeks in the same aging conditions (Fig. 32 b), the fracture is of mixed mode containing approx. 70% fraction of adhesive type failure and only about 30% of cohesive type failure.

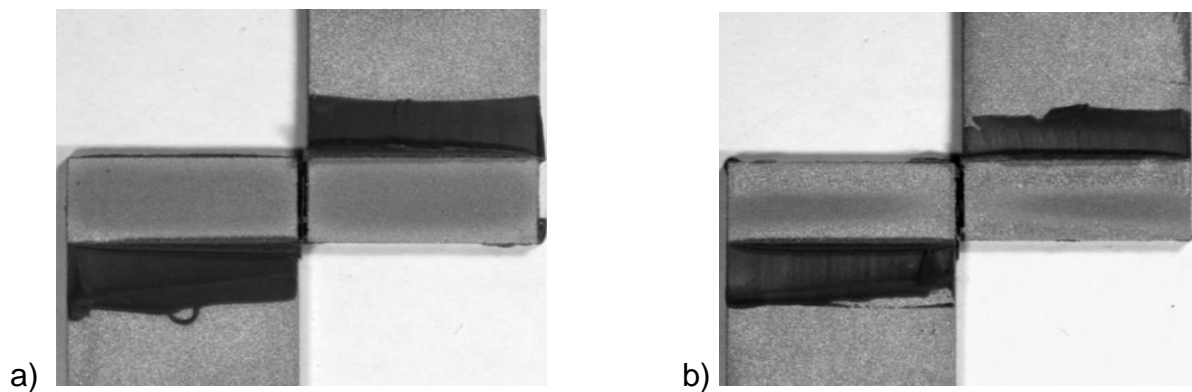

Figure 32. Fracture surfaces of the sand blasted and silane pretreated specimens aged at 60°C and 75%RH at the stressing level of 15% for a) one week and b) three weeks. The lighter part of the fracture surface is of adhesive type and the darker part of cohesive type.

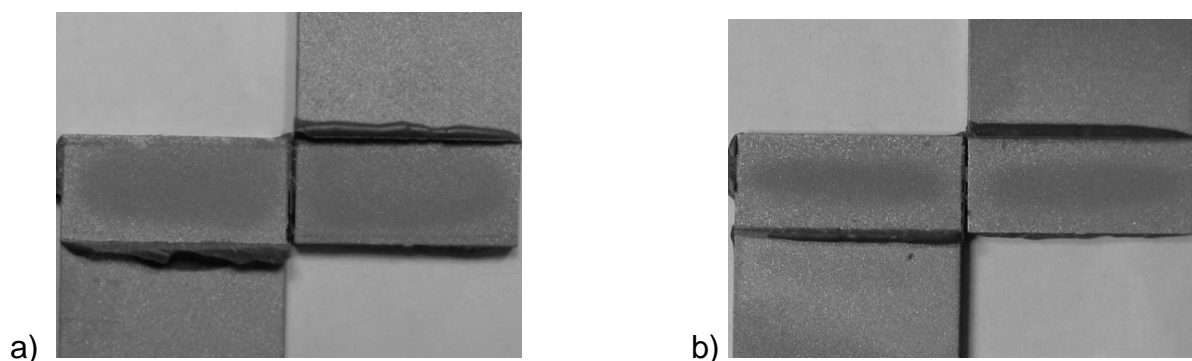

Figure 33. Fracture surfaces of merely sand blasted specimens aged at the temperature of 70°C and 75%RH for one day at the stress level of a) 5%, b) 15%.

The effect of increasing stress level on the fracture type of merely sand blasted specimens is shown in Figure 33. When the stressing level increases from 5% to 15% in the aging environment of 70°C and 75% RH, the fraction of the adhesive type fracture increases significantly already during one day of exposure. At the stress level of 5%, the fracture is approximately 80% of cohesive type, while at the stress level of 15%, it is only 60% of cohesive type.

Increase of the humidity from 75%RH to 85%RH also increases the tendency towards adhesive type of fracture. Figure 34 a shows that the fracture is 90% of cohesive type for the sand blasted and silane pretreated specimen after aging for one week at 60°C and 75% RH. When the relative humidity increases to 85%RH (Fig. 34 b), the fracture is of a mixed mode containing about 70% of cohesive and 30% of adhesive types of fracture.

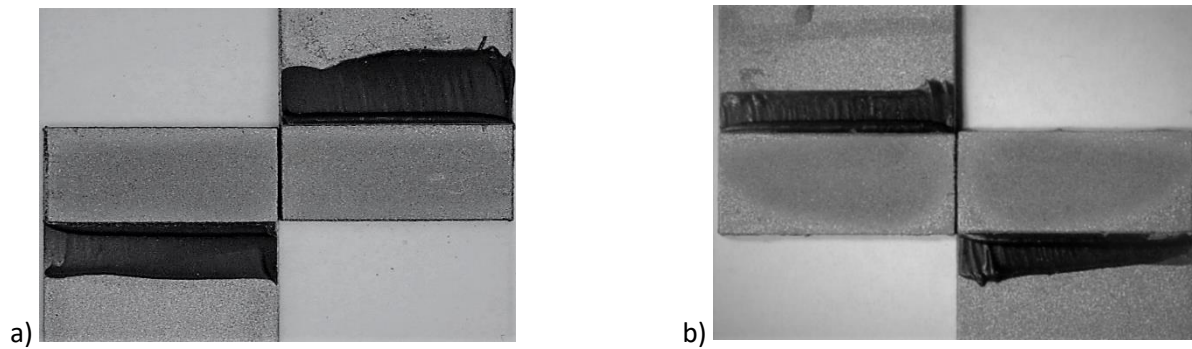

Figure 34. Fracture surfaces of the sand blasted and silane pretreated specimens stressed at the stressing level of 15% and aged for a) one week at 60°C and 75%RH and b) one week at 60°C and 85%RH.

The temperature did not have a strong effect on the fracture type of adhesively joined specimens in the studied temperature window. Figure 35 shows the fracture surfaces of the merely sand blasted specimens aged at 60°C and 75%RH (Fig. 35 a) and at 70°C and 75%RH (Fig. 35 b). Both specimens were stressed with a 5% load and aged for one day. In Figures 33 a and 33 b, the fracture type is of mixed mode containing approximately 80% of cohesive fracture and 20% of adhesive fracture.

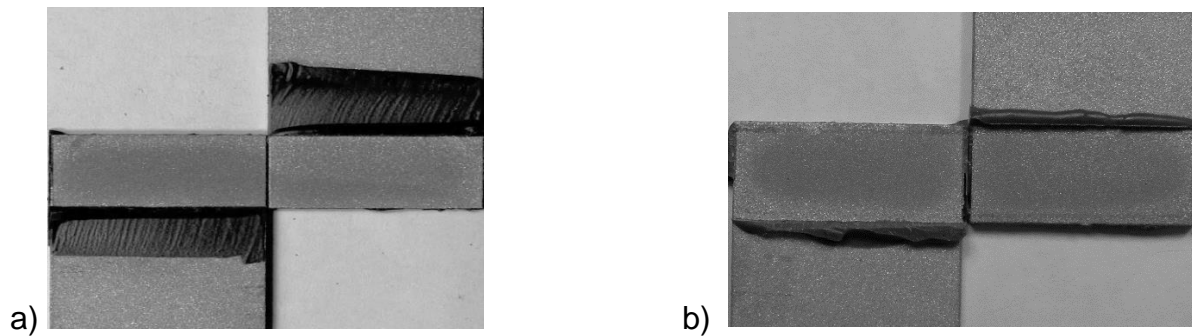

Figure 35. Fracture surfaces of the merely sand blasted specimens stressed at the 5% level and aged for one day under a) 60°C and 75% RH and b) 70°C and 75% RH.

The pretreatment of the adherend surfaces has a strong influence on the durability and the fracture type of the joint. The silane pretreatment together with the sand blasting retains the cohesive type failure for quite long aging times and high stress levels. For the merely sand blasted specimens, the adhesive failure is more typical even under milder aging conditions. Figure 36 shows the fracture surfaces of the sand blasted plus silane pretreated and of the merely sand blasted specimens aged for three days at 60°C and 75% RH at the stress level of 15%. As seen in Figure 36, the failure is nearly 100% of cohesive type for the sand blasted and silane pretreated specimens, while for the merely sand blasted specimens, the failure is of a mixed mode containing approximately 30% of cohesive type fracture and 70% of adhesive type of fracture. For the merely sand blasted specimens, the failure type changes more quickly and at lower stress levels towards the adhesive type, when compared with the sand blasted and silane pretreated specimens.

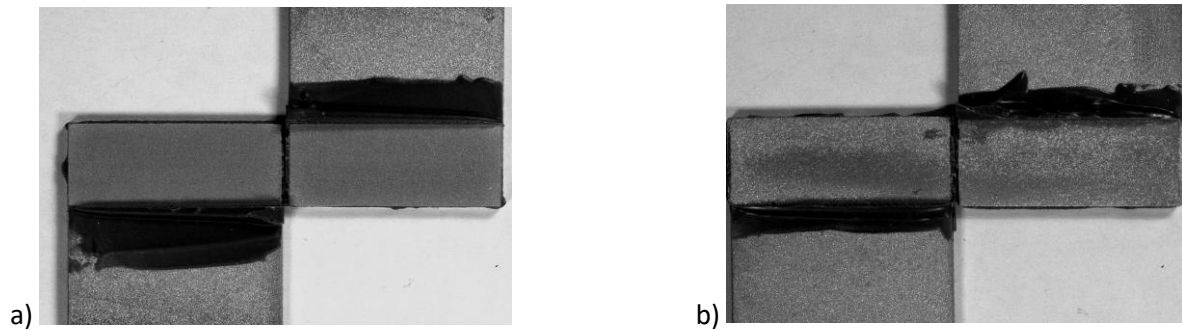

Figure 36. Typical fracture surfaces of the differently pretreated single lap joint specimens aged under 60°C and 75% RH at 15% stress for three days: a) sand blasting with silane pretreatment, and b) mere sand blasting.

The mere silane pretreatment of the adherend surfaces without sand blasting was also studied in some preliminary tests. Figure 37 shows the fracture surfaces of the merely silane pretreated specimens in the non-aged and non-stressed conditions and after aging for one week under 60°C and 75%RH at the stress level of 15%.

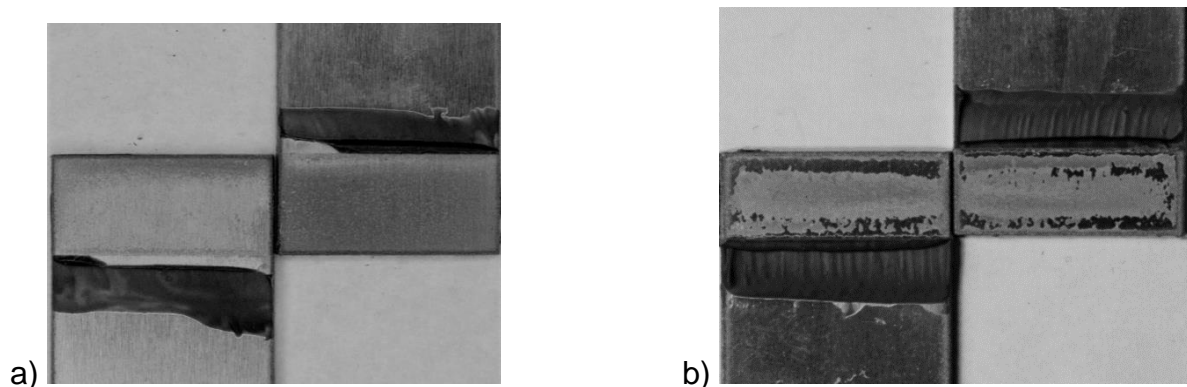

Figure 37. Typical fracture surfaces of the merely silane pretreated specimens in the non-aged and non-stressed condition (Fig. 37 a), and as aged for one week at 60°C and 75%RH and at the 15% stress level (Fig. 37 b).

The fracture type of the merely silane pretreated specimens is nearly completely adhesive already for the non-aged and non-stressed specimens. In addition, the strength of the merely silane pretreated specimens decreased rapidly when aged at 60°C and 75%RH at the stress level of 15%. The silane supplier also recommends that the sand blasting process should be connected with the silane pretreatment. As our preliminary test results also revealed the weak durability and low strength of the merely silane pretreated specimens, in all further tests the silane treatment of the surfaces was accompanied by the sand blasting pretreatment.

9. ANALYSIS AND DISCUSSION OF THE RESULTS

In this chapter, the effects of different aging factors, including temperature, humidity, and static loading on the durability and strength of the studied adhesive joints is analyzed and discussed. The influence of different pretreatments (mere sand blasting or sand blasting plus silane pretreatment) on the durability of the studied joints is also analyzed.

9.1. Effects of temperature and humidity on aging

In the beginning of the tests, the effect of static loading on the residual strength of the joints was studied under ambient laboratory conditions, i.e., at 23°C and 45 ± 10 % RH. Figure 38 shows the effect of static loading on the residual strength values of the merely sand blasted single lap joint specimens kept at room temperature under different loads, as well as of the specimens aged at 60°C and 75% RH without load and under a 10% static load. As Figure 38 indicates, under dry room temperature conditions the residual strength of the joint is at the same level as the initial strength of the joint even after six weeks of exposure at stress levels of 5%, 10% and 15% of the initial strength. Figure 38 also shows that aging of the specimens at 60°C and 75%RH without static loading seems to decrease the strength level a little bit but does not drop it significantly during the six week exposure. On the other hand, loading of the specimens at the stress level of 10% of the initial strength of the joint drops the strength to zero in three weeks at 60°C and 75%RH. When the strength dropped to zero, the specimens were typically broken during the aging process in the aging cabinet.

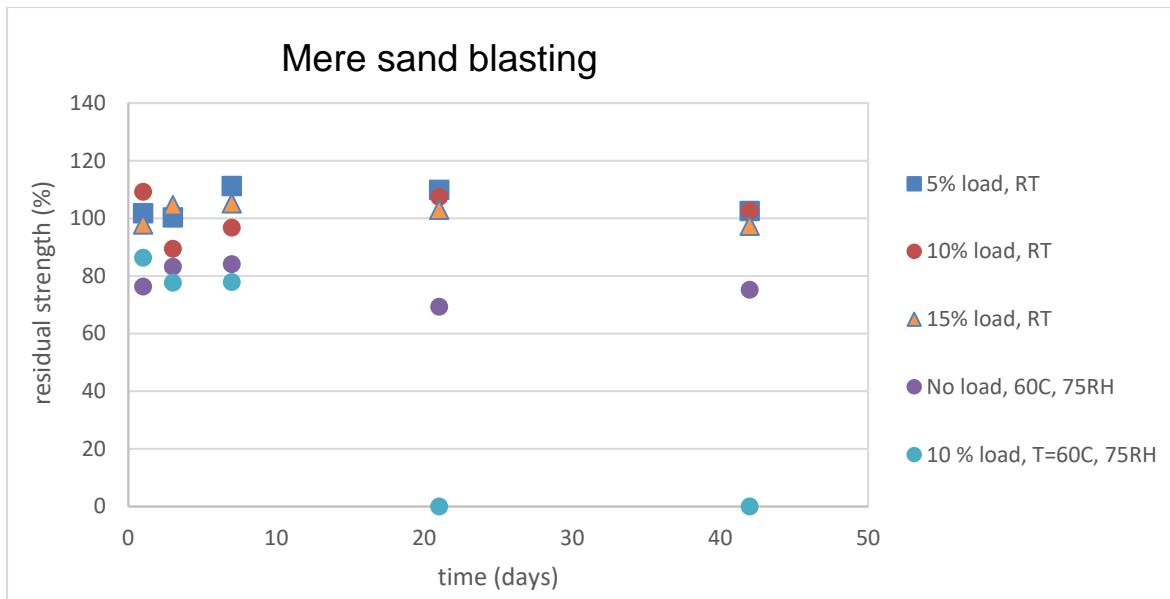

Figure 38. Residual strength of sand blasted specimens as a function of time when aged for different times at different stress levels at room temperature or at the relative humidity of 75% at the temperature of 60°C at 0% and 10% stress levels.

The influence of temperature and humidity on aging was studied at the temperatures of 60°C and 70°C and at the relative humidity values of 75% or 85%, when the specimens were stressed to the loading levels of 0, 5, 10 and 15% of the initial strength of the joint. Figure 39 shows the effect of temperature on the residual strength of sand blasted and silane pretreated single lap joint specimens, when aged for different times at 60°C or 70°C, at the relative humidity of 75%, and at different stress levels.

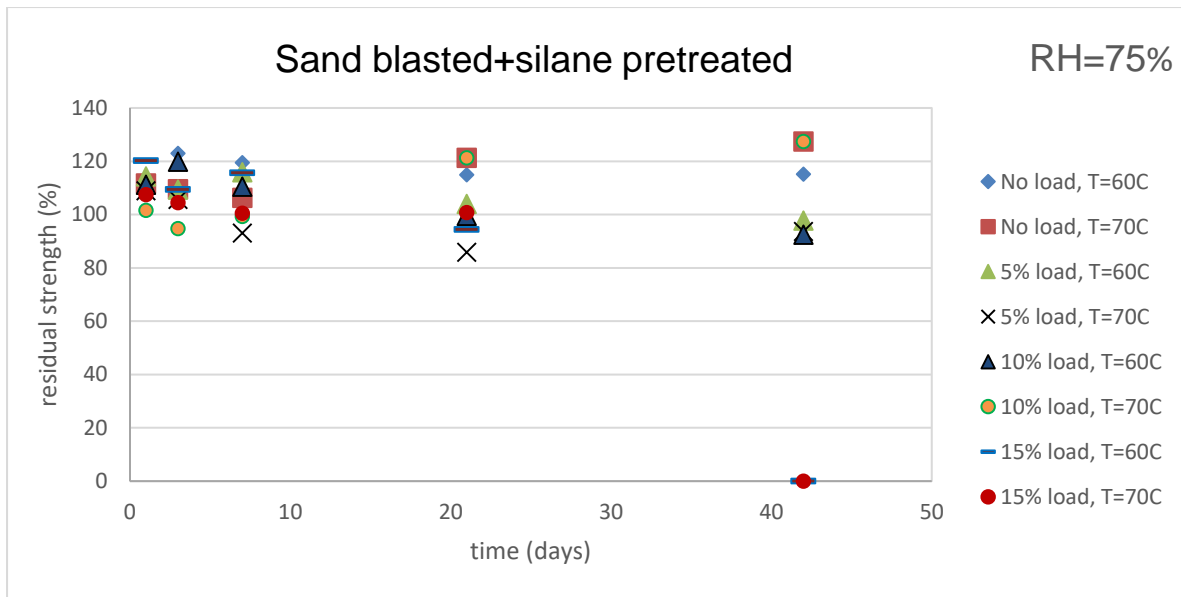

Figure 39. Residual strength of sand blasted and silane pretreated specimens as a function of time when aged at the temperatures of 60°C or 70°C and 75% RH at different stress levels.

Based on the test results shown in Figure 39, it seems that the temperature increase from 60°C to 70°C does not have a strong effect on the durability and residual strength values when the relative humidity is 75% for all studied loading levels. The strength of the joint drops only by a small amount and stays at quite the same level as the initial strength even after six weeks (42 days) of aging exposure. Under these conditions, the sand blasted and silane pretreated specimens fail only when stressed at the 15% loading level and aged for six weeks at either 60°C or 70°C.

Figure 40 shows the effect of the relative humidity on the residual strength values of the sand blasted and silane pretreated lap joint specimens aged at the temperature of 60°C, relative humidity values of 75% and 85%, and at different stress levels. Based on the results, the relative humidity increase from 75% to 85% does not seem to affect the residual strength of the joint at the stress levels 0% or 5%, but when the stress level is increased to either 10% or 15%, the strength of the joint drops to zero after a certain stress level dependent aging time.

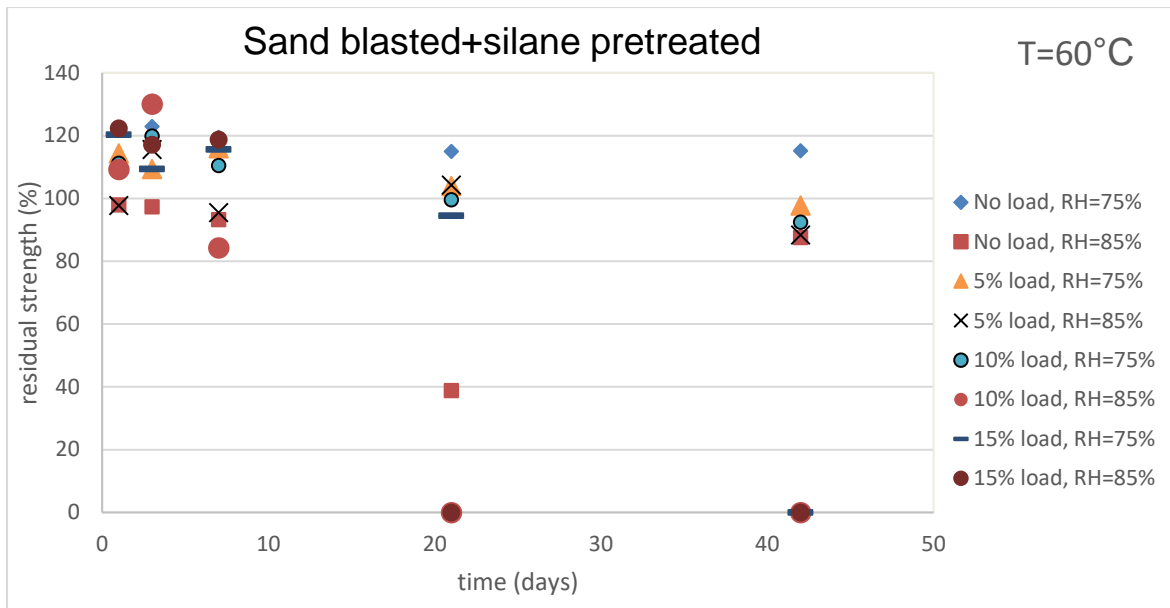

Figure 40. Residual strength of sand blasted and silane pretreated specimens as a function of time when aged at the relative humidity of 75% or 85% at the temperature of 60°C at different stress levels.

Figure 41, in turn, shows that the increase of temperature from 60°C to 70°C leads to a more rapid weakening of the joint, when sand blasted and silane pretreated specimens are aged at the relative humidity of 75% or 85%. A particularly rapid drop of strength is observed at the loading levels of 10% and 15% of the initial strength, when the relative humidity value is 85%. Figure 41 also shows that at the relative humidity value of 85%, the strength of the joint decreases faster at the loading level of 10% than at the relative humidity value of 75% at the loading level of 15%. It therefore seems that the humidity increase from 75% to 85% has a stronger effect on the aging behavior of sand blasted and silane pretreated specimens than the temperature increase from 60°C to 70°C . This might be due to the moisture induced internal stresses in the joint and in the adhesive itself, as such stresses are known to accelerate the aging phenomena together with increasing temperature. It could also be a consequence of the influence of the moisture content of the adhesive on its glass transition temperature (T_g), as will be discussed later on.

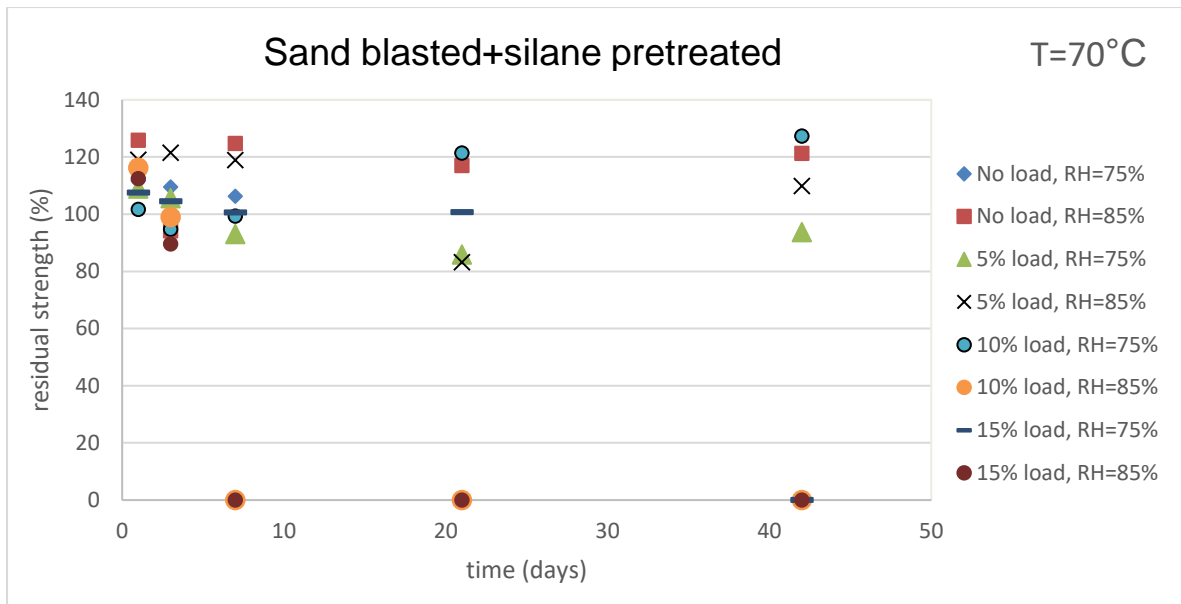

Figure 41. Residual strength of sand blasted and silane pretreated specimens as a function of time when aged at the relative humidity of 75% and 85% at the temperature of 70°C at different stress levels.

Figure 42 shows the effect of temperature on the residual strength values of the mere sand blasting pretreated lap joint specimens aged at the temperatures of 60°C or 70°C and at the relative humidity of 75% at different stress levels. As seen, the strength of the specimens first increases when aged at 70°C and 75%RH. In comparison, for the same specimens aged at 60°C and at the relative humidity of 75%, the strength starts to decrease immediately when the aging treatment begins. This behavior was noticed at all loading levels. The explanation for this might be that in the beginning of the tests at the higher temperature new bonds start to form in the adhesive as well as between the adhesive and the adherend, strengthening the entire joint (continuing polymerization). At the same time, weakening of the joint or the adhesive itself starts and reduces the strength of the joint. At longer times, aging of the joint proceeds and leads to the total loss of the strength in quite a short time, when the loading level exceeds 5% of the initial strength. Similar to the case of sand blasted plus silane pretreated specimens, the temperature increase from 60°C to 70°C does not markedly affect the durability of the joint.

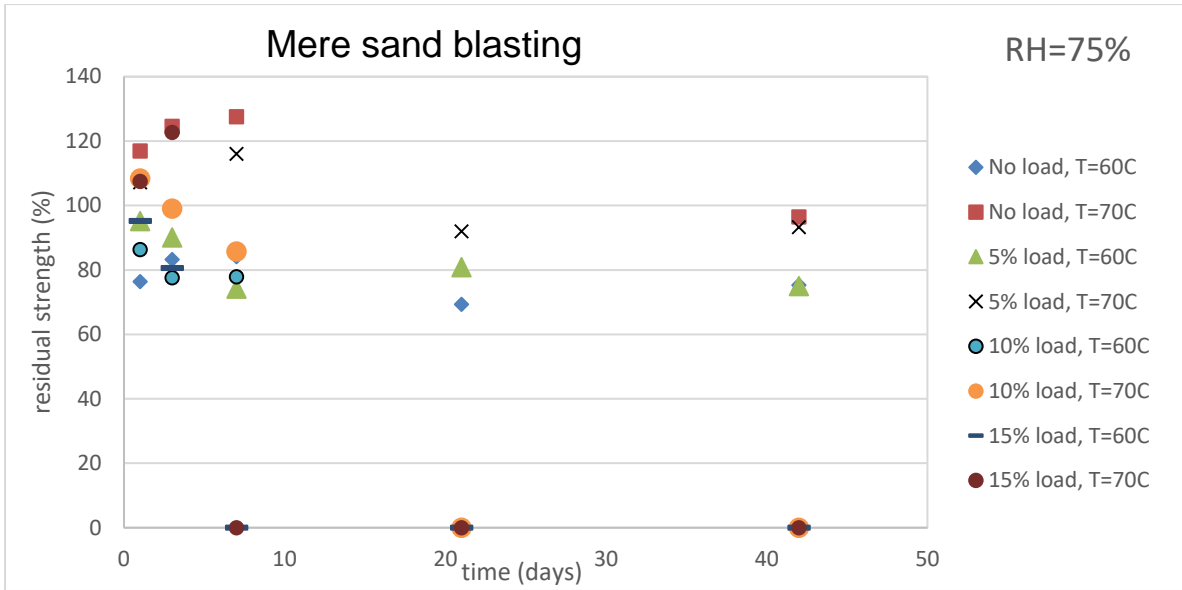

Figure 42. Residual strength of the merely sand blasted specimens as a function of time when aged at the temperatures of 60°C and 70°C and at 75% RH at different stress levels.

Figure 43 shows the effect of humidity (75% or 85%) on the residual strength of the mere sand blasting pretreated lap joint specimens at the temperature of 60°C, where the differences between the results are only minimal.

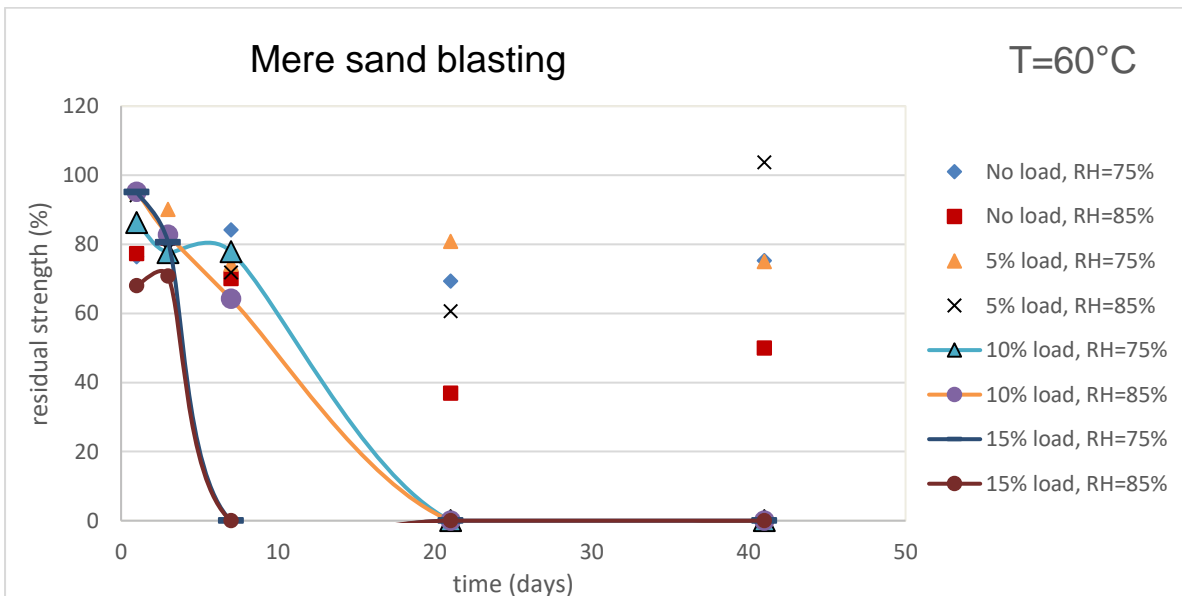

Figure 43. Residual strength of the merely sand blasted specimens as a function of time when aged at the relative humidity values of 75% and 85% at the temperature of 60°C at different stress levels.

At 70°C, an increase in the relative humidity from 75% to 85% accelerates the aging of the joint of the merely sand blasted specimens markedly, as shown in Figure 44, where the strength drops rapidly and leads to failure already at the 5% load of the initial strength during three weeks of exposure. It seems that in these specimens the increase of temperature from 60°C to 70°C accelerates the water diffusion into the adhesive and water migration to the adhesive-adherend interface, thereby weakening the joint and the adhesive itself. Humidity may break the bonds between the adhesive and the adherend, and it may also cause swelling or/and plasticization of the adhesive. In that way, it may increase the stresses in the joint and weaken the bonds between the adhesive and the adherend. According to the results of this work on merely sand blasted aluminum adherends joined with epoxy adhesive, it seems that some critical threshold value of the relative humidity is exceeded between the values of 75% and 85%. Above this value, the joint durability and strength of the joint drop rapidly and by large amounts, even when there is no stress acting on the joint. Especially clear this is at the temperature of 70°C. This kind of behavior is in accordance with the observation of Gledhill et al. [33], who claimed that there exists a critical concentration of water in the adhesive, which leads to strong weakening of the joint.

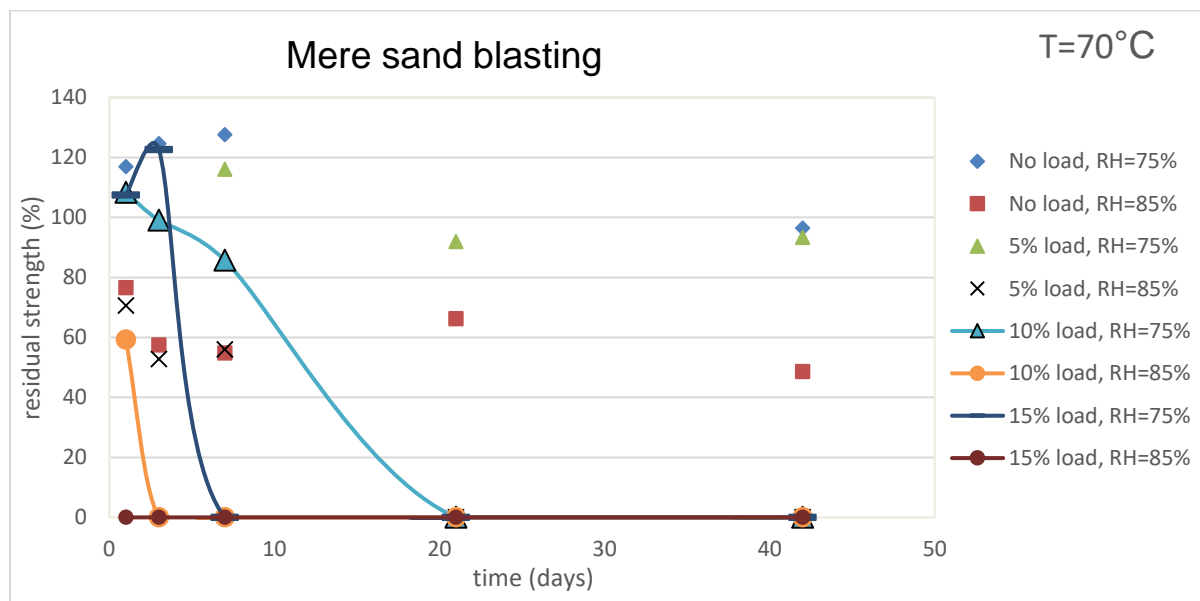

Figure 44. Residual strength of the merely sand blasted specimens as a function of time when aged at the relative humidity values of 75% and 85% at 70°C at different stress levels.

The study of the fracture surfaces reveals that an increase in the relative humidity and temperature also increases the tendency for the formation of adhesive type of fracture, which is directly connected to the durability and strength of the joint. The humidity

seems to have a stronger influence on the fracture type than temperature. The adhesive type of fracture is mostly seen at higher humidity values, higher temperatures, and in merely sand blasted specimens. For sand blasted and silane pretreated specimens, the increase of the relative humidity from 75% to 85% increases less the fraction of the adhesive type fracture.

In theory, it is also possible that high humidity and high temperature together with static loading lower the T_g temperature of the adhesive. This may change the properties of the adhesive and lower the maximum service temperature of the joint. The adhesives used normally below their T_g temperature may lose part of their mechanical strength, if used above their T_g temperature. The eventual lowering of the T_g temperature due to the increased moisture content may be one reason for the observed strong influence of the relative humidity on the rate of the aging process.

9.2. Influence of surface pretreatment on aging

The adherend surfaces were either mechanically pretreated by mere sand blasting, or sand blasted and chemically pretreated with silanes before bonding. The mechanically pretreated specimens were acetone degreased, sand blasted, and again acetone decreased. The silane pretreated specimens were acetone degreased, sand blasted, acetone degreased, and silane pretreated. The lap joint specimens were exposed to different levels of static loading at the temperatures of 60°C and 70°C and relative humidity values of 75% and 85%. When the relative humidity was 75%, there were no large differences observed in the results between the specimens aged at 60°C or 70°C.

Figure 45 shows the influence of the surface pretreatment on the residual strength values of the studied single lap joints as a function of time when aged at the temperature of 70°C and 75%RH at different stress levels. As the results show, the strength of the merely sand blasted specimens drops faster and at lower stress levels than that of the sand blasted and silane pretreated specimens. For the merely sand blasted specimens, the strength of the joint drops to zero during one week's exposure at the 15% stress level, and during three week's exposure at the 10% stress level. In the case of sand blasted and silane pretreated specimens, the strength of the joint drops to zero between three and six weeks of exposure at the 15% stress level of the initial strength. This implies that the silane pretreatment induces stronger primary bonds between the adhesive and the adherend when compared to the secondary bonds that will be formed in the case of mere mechanical pretreatment. The silane pretreatment also enhances the durability of the joint under high humidity conditions, as can be seen in Figure 46, where the durability and strength of the joints with different pretreatments are compared at RH = 85% and T=70°C.

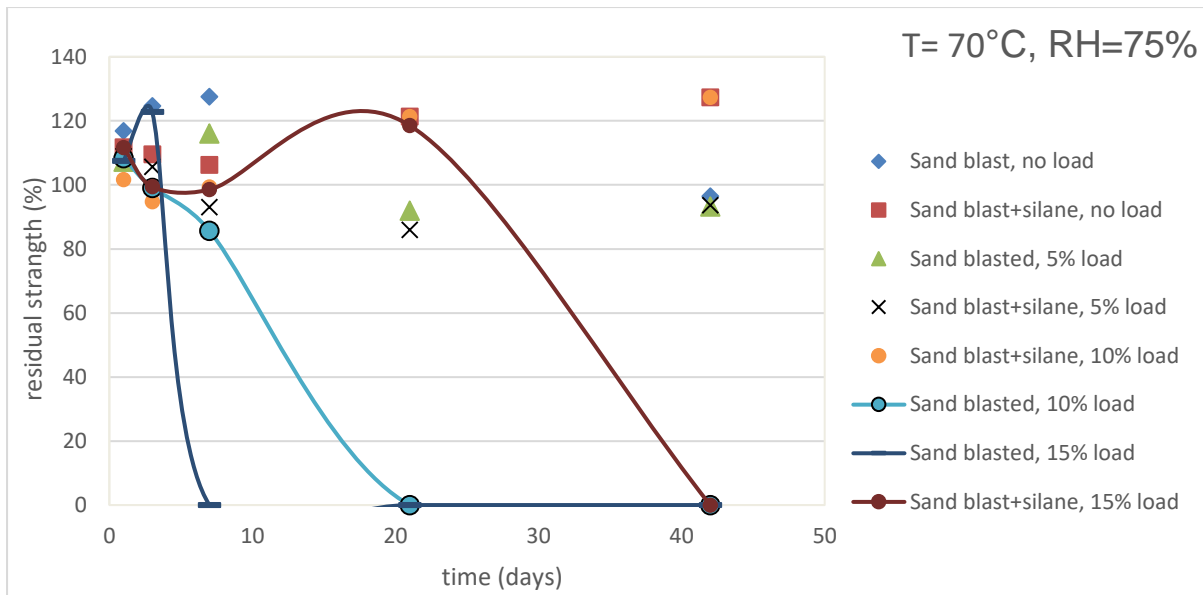

Figure 45. Influence of the adherend surface pretreatment on the residual strength of the joint as a function of time, when the joint is aged at 70°C and 75%RH at different loading levels.

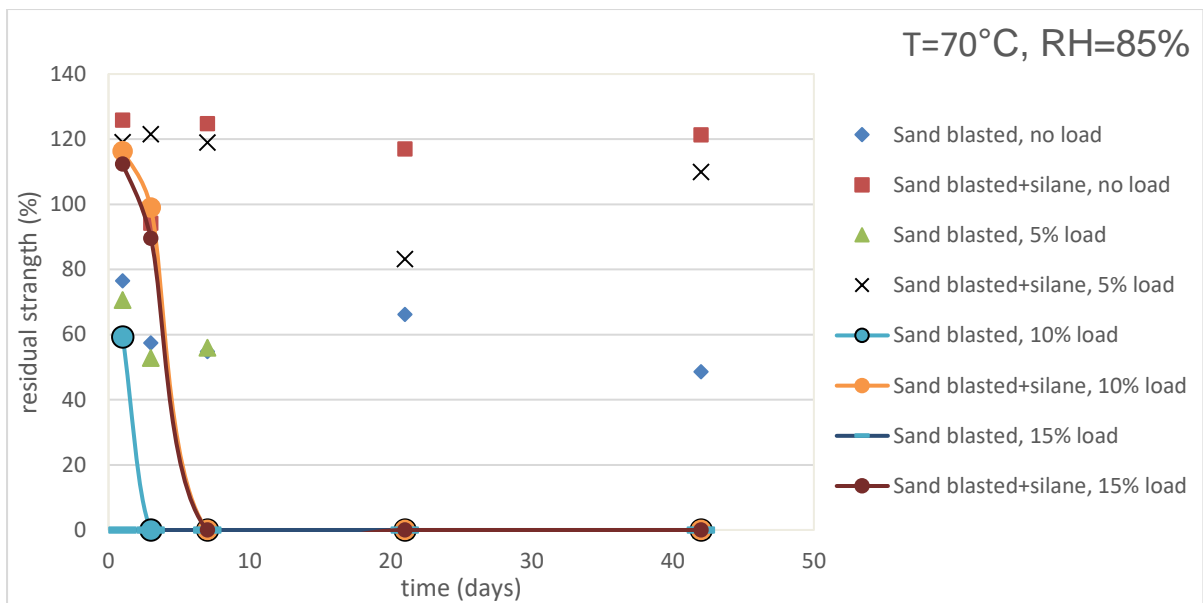

Figure 46. Influence of the adherend surface pretreatment on the residual strength of the joint as a function of time when the joint is aged at 70°C and 85%RH at different loading levels.

In the case of the merely sand blasted specimens, all joints fail in just one day of exposure at the stress level of 15%, and they also fail quite quickly at the stress level of 10%. Even without any stress, the strength of the joint weakens remarkably during

six week's exposure at 70°C and relative humidity of 85%. The strength of the stressed sand blasted and silane pretreated specimens drops to zero during one week's exposure at the highest stress levels 10% and 15% under these conditions. It can therefore be stated, that in the case of mere sand blasting pretreatment this type of epoxy adhesive aluminum joint cannot withstand the environment of 70°C and 85% R.H.

The silane pretreatment enhances the durability and strength of the joint under the studied humidity and temperature conditions. At the beginning of the aging tests, the strength of the silane pretreated joints will first increase when compared to the strength of unaged specimens. This can be due to the high temperature enhancing the curing reaction to its final strength, while the humidity will react with silane instead of reacting with the adhesive or the adherends and weakening them. The strength of the silane pretreated specimens also drops to zero at the stress levels of 10% and 15%, but only after longer exposure times than for the merely sand blasted specimens. In the case of unstressed or 5% stressed specimens, the strength of the joint does not decrease below the original level during the six weeks of exposure when using the silane pretreatment. It seems that for merely sand blasted specimens, the weakening and eventual collapse of the joint strength are mainly due to the weakening of the adhesive or the adhesive/adherend interface due to the humidity causing breakage of the secondary bonds. For silane pretreated specimens, the silane enhances the durability of the joint especially in humid conditions, as it is able to react with water at the adhesive/adherend interface forming strong covalent bonds from the metal substrate to the adhesive. In that way, it may retard water diffusion to the adhesive/adherend interface and to the adhesive itself, decreasing the rate of the aging process. Silanes will also improve the hydrolytic stability of the aluminum joint. Formation of the weak hydrated layer on the aluminum surface can be inhibited and stresses in the joint may stay at a lower level, which also seem to increase the strength and durability of the adhesive joint.

The study of the fracture surfaces shows that the pretreatment method has also a strong influence on the fracture type of the joint. The silane pretreatment together with sand blasting seems to promote the cohesive type of fracture of the joints even after longer aging times and at higher stressing levels, while the mere sand blasting process seems to lead to an adhesive type of fracture already at short aging times and at low stressing levels. There seems to be a clear relationship between the strength of the joint, the fracture type, and the pretreatment method. For the sand blasted and silane pretreated specimens, the fracture type changes from cohesive type to mixed mode type only at the highest relative humidity of 85% RH and at the higher stressing levels of 10% or 15% of the initial strength. At the same time, the strength and durability of the joint decrease, as shown above. At the lower stressing level of 5% of the initial strength, the fracture type of the sand blasted and silane pretreated specimens is mostly cohesive even after a six week exposure at 70°C and 85%RH. The strength of the joint also stays high, as seen in Figure 46. For the merely sand blasted specimens,

the fracture type of the joint is mostly adhesive already at the 5% stressing level and after a one week exposure under the aging conditions of 70°C and 85% RH. As depicted in Figure 46, also the strength drops markedly.

9.3. Effect of static loading on aging

The single lap specimens were stressed during aging with the loadings of 0, 5, 10, and 15% of the initial strength of the joint. The stress was generated with a stressing jig based on the compression of springs, as described in Chapter 7. The stressed specimens were either mechanically pretreated by mere sand blasting or mechanically plus chemically pretreated by sand blasting and a silane pretreatment. Part of the mechanically pretreated specimens were protected with silicone at the edges of the joint to prevent the penetration of moisture into the joint. The stressed specimens were aged at constant temperatures of 60°C and 70°C and at the relative humidity values of 75% and 85%. Typically the durability and the residual strength of the joint decrease as a function of time when the joint is stressed during aging. Figure 47 shows the effect of the loading level on the residual strength of the merely sand blasted lap joints as a function of time at 70°C and 75%RH, indicating that at the loading levels of 0% and 5% of the initial strength, the residual strength drops only by a small amount and then stabilizes to a certain level.

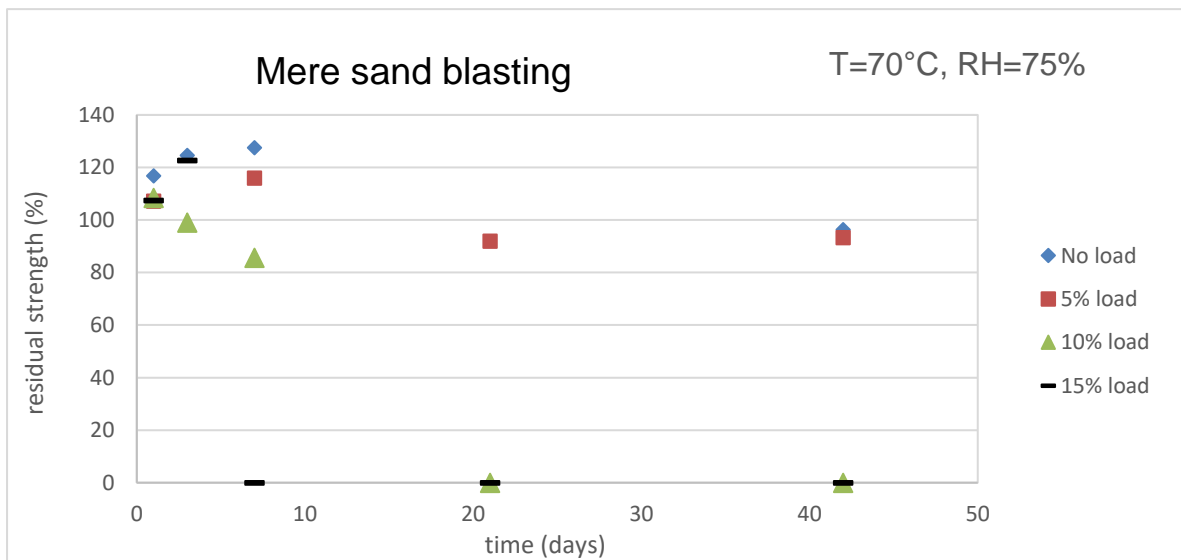

Figure 47. Residual strength of the studied joints as a function of time for the merely sand blasted specimens after aging at 70°C and 75%RH at different stressing levels.

Figure 48, in turn, shows the residual strength values of the sand blasted and silane pretreated specimens under the same aging conditions and stressing levels as in

Figure 47 for the merely sandblasted specimens. According to the aging test results, the residual strength and the durability of the sand blasted and silane pretreated joints stay at higher levels compared to the merely sand blasted specimens, especially at the higher loadings of 10% and 15%. The strength of the joint drops to zero only for the specimens aged for six weeks at the highest loading level of 15% of the initial strength. The weakening of the sand blasted and silane pretreated joints as well as of the merely sand blasted joints stressed under the aging conditions of 60°C and 75% RH is quite similar to the weakening of the stressed joints under 70°C and 75% RH.

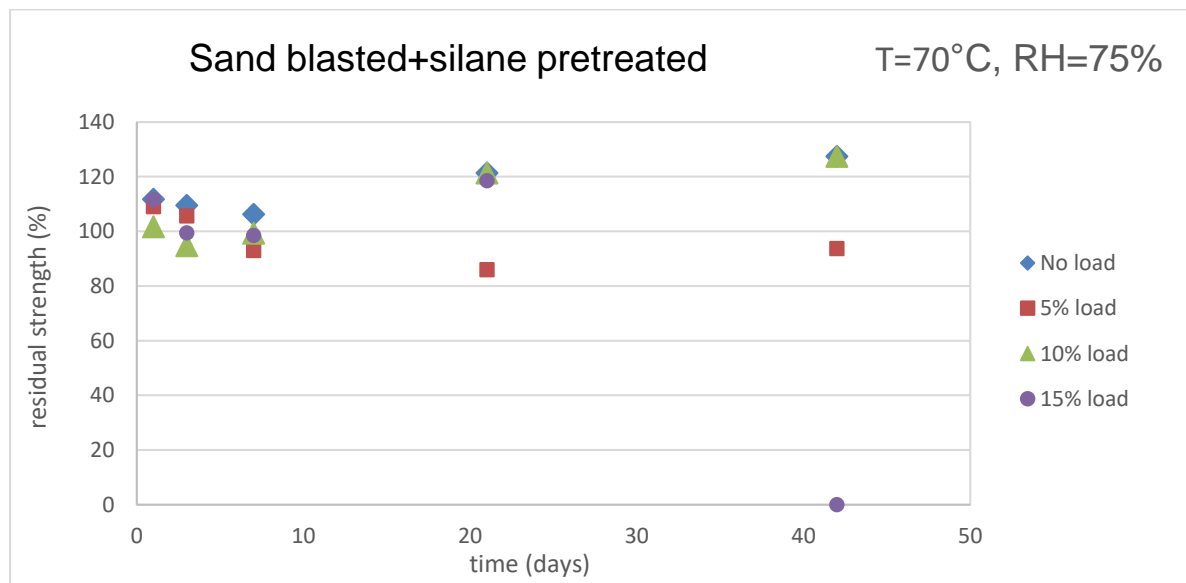

Figure 48. Residual strength of the studied joints as a function of time for the sand blasted and silane pretreated specimens after aging at 70°C and 75%RH at different stressing levels.

Based on the presented results, it seems that the increase of the stressing level in the aging tests increases the tendency for the formation of adhesive type of fracture. The fracture type of the sand blasted specimens is mostly adhesive even at quite low static loads during the aging process. The tendency for the formation of adhesive type of fracture increases also for the silane pretreated specimens, but this occurs only at higher loading levels and after longer aging times as compared to the merely sand blasted specimens. At room temperature, the fracture type of the joints is cohesive, independent of the loading level or the pretreatment method.

9.3.1 Apparent threshold stress for accelerated aging

As discussed above, the adhesively joined specimens were stressed at different constant static loading levels (0, 5, 10 and 15%) of the initial strength of the joint during

the aging period. The aim was to determine, whether there exists a definite loading level above which the strength of the joint collapses quite rapidly after only a small reduction before that. This loading level is here referred to as the threshold value of the loading stress for the initiation of accelerated aging and the catastrophic failure of the joint.

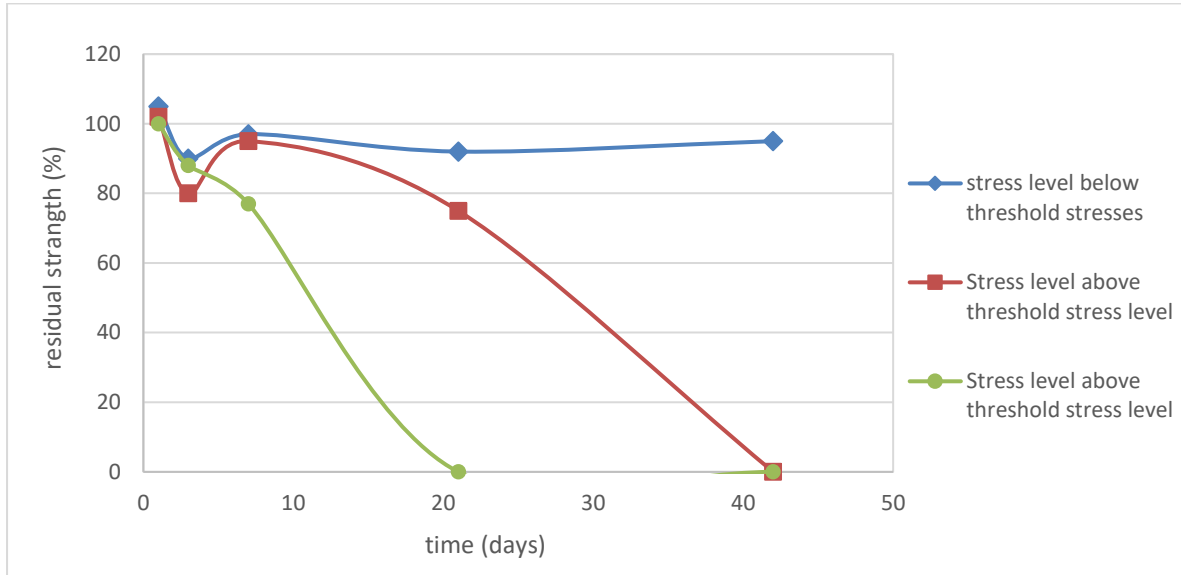

Figure 49. Schematic presentation of the residual strength of specimens as a function of time when aged at stressing levels below and above the threshold stress value.

Figure 49 shows schematically the behavior of the joint at the loading level below the threshold stress value, and two examples of the behavior at loading levels above the threshold stress value.

As Figure 49 indicates, the collapse of the strength of the joints takes place after only a small reduction of the strength when the threshold stress level is exceeded. When the stress level is below the threshold stress, the strength of the joint does not seem to drop suddenly without any warning. According to the earlier experience and the results of the present tests, it seems that such a threshold stress value may exist for the specimens aged under stress. At the aging conditions of 75%RH and the temperature of either 60°C or 70°C, this threshold stress value seems to be between 5% and 10% of the initial strength of the joint for the merely sand blasted specimens, and between 10% and 15% for the sand blasted and silane pretreated specimens. In the aging at 75%RH, the temperature increase from 60°C to 70°C does not seem to affect this threshold stress value for neither type of the specimens. The silane pretreatment together with sand blasting increases the threshold stress value when compared to mere sand blasting. It also increases the durability of the joint as compared to mere sand blasting. When aged at 70°C and 75%RH, the strength of the

silane pretreated joints collapses only after six weeks of exposure when stressed at the 15% load. At the stressing levels of 5% or 10%, the strength of the sand blasted and silane pretreated joints decreases only by small amounts and stays close to the initial strength level even after six weeks of exposure under these aging conditions. For the merely sand blasted specimens at the loading level of 10%, the strength first decreases slightly and then unexpectedly collapses to zero after three weeks (21 days) of exposure at both 60°C and 70°C and 75%RH.

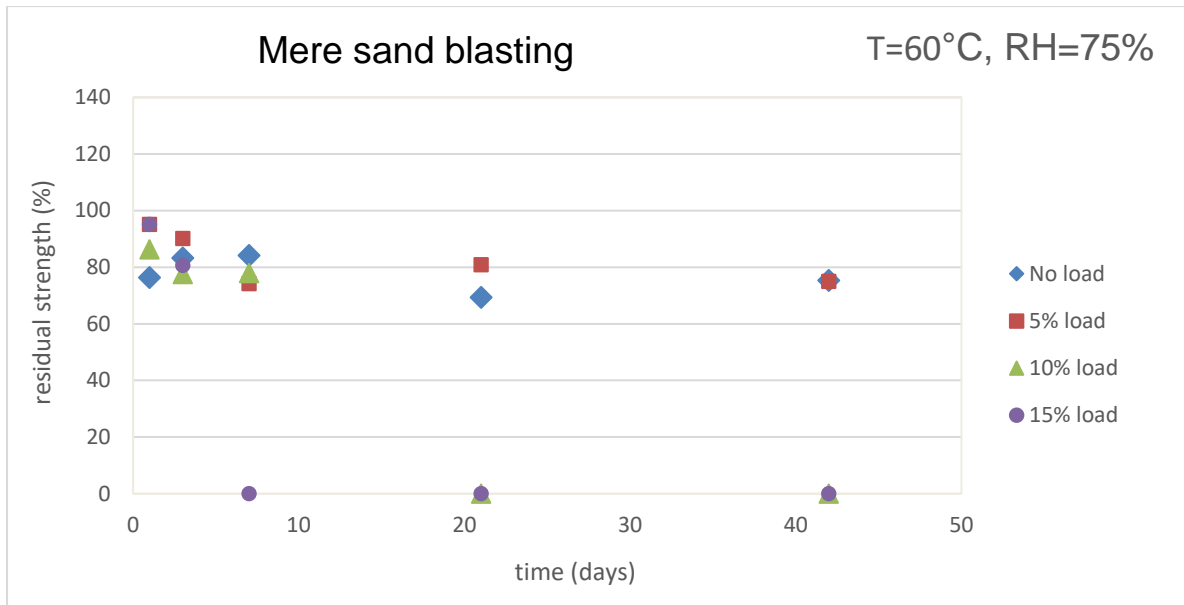

Figure 50. Residual strength of the merely sand blasted specimens as a function of time when aged at 60°C and 75%RH at different stressing levels.

Figure 50 shows the collapse of the strength of the sand blasted joints to zero at the loading level of 10% during the three week (21 days) exposure at 60°C and 75RH. Similar behavior is seen for the specimens aged at the 15% load, but it expectedly occurs at shorter times, during only one week (7days) of exposure. According to Figure 42, the temperature increase from 60°C to 70°C at the relative humidity value of 75% does not affect either the residual strength value or the threshold stress for the merely sand blasted specimens. Similar behavior is also noticed for the sand blasted and silane pretreated specimens under the same aging conditions. The weakening behavior at 75%RH is similar at both 60°C and 70°C.

When the relative humidity increases from 75%RH to 85%RH, the threshold value for the loading stress decreases. According to the current results on the sand blasted and silane pretreated specimens at 85%RH, the threshold stress seems to be between 5% and 10% of the initial strength of the joint, when the aging takes place at either 60°C or 70°C. This means that the temperature increase from 60°C to 70°C does not seem to affect the threshold stress level, but the strength of the joint appears to drop more rapidly when the temperature is increased. At 10% and 15% loads, the strength of the

joint collapses to zero in three weeks (21 days) at 60°C, while at 70°C the collapse takes only one week (7 days). Figure 51 shows the residual strength values of the sand blasted and silane pretreated specimens when aged at different loading levels at 60°C and 85%RH.

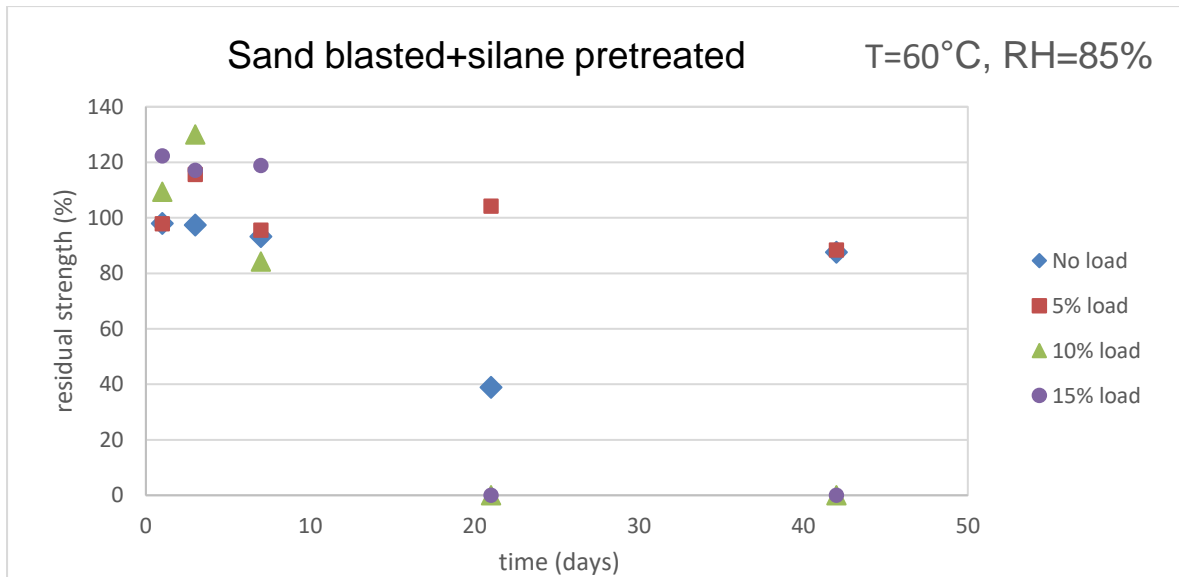

Figure 51. Residual strength of the sand blasted and silane pretreated specimens as a function of time after aging at 60°C and 85%RH with different stressing levels.

For the merely sand blasted specimens, the increase of temperature from 60°C to 70°C at the relative humidity value of 85%RH weakens the joint remarkably, and at 70°C, the joints fail during three weeks (21 days) of exposure at the loading level of only 5%. For these specimens in these conditions, the threshold stress level seems to be between 0 and 5% of the initial strength of the joint, and at the 15% load the joint fails already during the first day of exposure. When the loading level is 10%, the joint fails in three days. Figure 52 shows the residual strength values of the merely sand blasted specimens stressed at different loading levels under the aging conditions of 70°C and 85%RH. According to the results at these conditions, the joints fail very rapidly under almost any load.

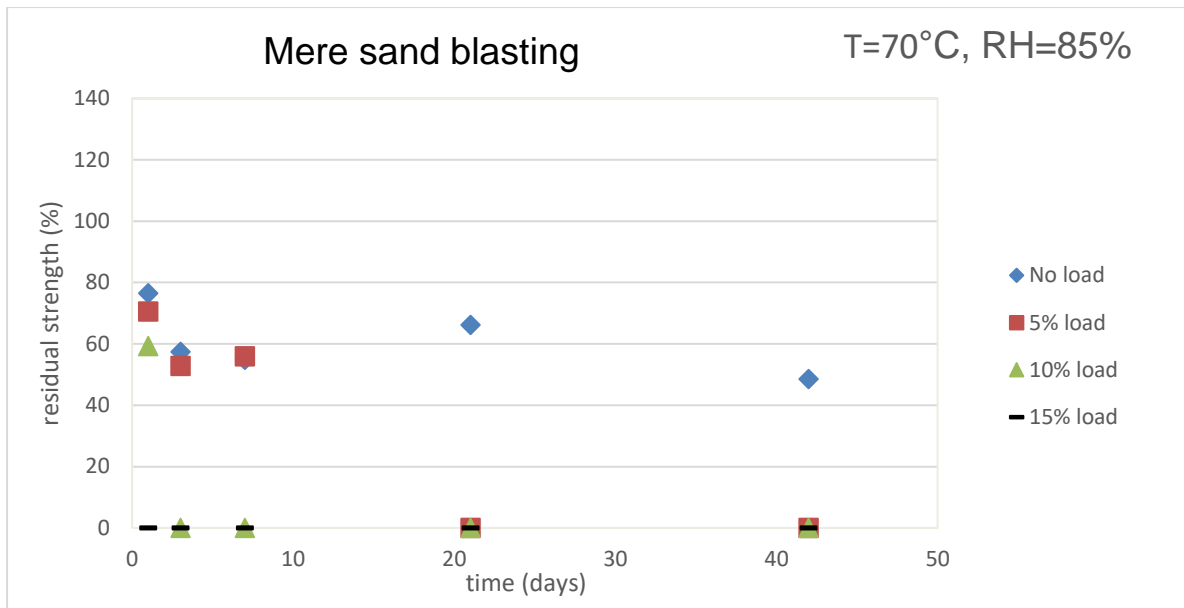

Figure 52. Residual strength of the merely sand blasted specimens as a function of aging time when aged at 70°C and 85%RH at different stressing levels.

At the aging conditions of 60°C and 85%RH, the strength of the joints of merely sand blasted specimens collapses to zero during one week (7days) at the stressing level of 15%, and in three weeks (21 days) at the stressing level of 10%. The threshold stress level for the merely sand blasted specimens seems to be between 5 and 10% of the initial strength of the joint when the aging takes place at 60°C and 85%RH. Table 4 summarizes the threshold stress levels of the differently pretreated specimens, which are aged and stressed at different aging conditions.

Table 4. Dependence of the threshold stress level on the pretreatment method of the specimens and the aging conditions in the aging tests.

Aging condition and pretreatment method	Threshold stress level (%)
60°C, 75RH, silane	10-15%
60°C, 75RH, sand blasted	5-10%
60°C, 75RH, sand blasted + silicone protection	5-10%
70°C, 75RH, silane	10-15%
70°C, 75RH, sand blasted	5-10%
60°C, 85RH, silane	5-10%
60°C, 85RH, sand blasted	5-10%
70°C, 85RH, silane	5-10%
70°C, 85RH, sand blasted	0-5%

As described earlier in Chapter 4, the diffusion of water through the adhesive has been explained to be one of the main processes that contributes to the aging of the adhesive. Besides the diffusion of water, the decrease of the glass transition temperature T_g of the adhesive due to the humidity may also decrease the strength of the adhesive joint. The T_g temperature may decrease considerably due to moisture, which can weaken the mechanical properties of the adhesive. The fracture surface studies of this work, however, reveal that decrease of the T_g temperature of the adhesive is not the main mechanism lowering the strength of the adhesive joint in high humidity and high temperature conditions. The results show that the decreasing durability and strength of the joint are connected to the adhesive type of fracture of the joint. Also in the literature, it has been claimed that water affects the mechanical properties and glass transition temperature of adhesives but that they are not the most important factors causing the weakening of the joint. Water attacking the interfaces is also important [40]. The reduced strength is a consequence of the failure of the bonds between the adhesive and the adherend. The strength and durability of the joint are also strongly dependent on the pretreatment method and the type of the bonds between the adhesive and the adherend. The silane pretreatment, which enhances the formation of strong bonds between the adhesive and the adherend, increases the durability and strength of the joint. The decrease of the T_g temperature of the adhesive may still be one of the factors leading to the decrease of the strength of the joint.

The static loading of the joints under humid and high temperature conditions can stretch the molecular bonds and make the joint structure more open to water diffusion. This accelerates the water diffusion and makes the joint structure more sensitive to moisture. When the structure is subjected to static loading under the aging conditions, the molecular bonds may also need only a small incremental damage to cause the total failure of the joint. The external activation energy needed to break the bonds becomes small, and it can be introduced by the aging processes.

9.3.2. Factors affecting the threshold stress value

In the current tests at the lower humidity level (75%RH), the temperature increase from 60°C to 70°C does not affect the threshold stress level. However, the silane pretreatment together with sand blasting increases the threshold stress level as compared to the merely sand blasted specimens. It also shifts the collapse of the strength to longer aging periods. For merely sand blasted specimens, the threshold stress level was estimated to be between 5 and 10% of the initial strength of the joint, while for silane pretreated specimens, it was typically between 10% and 15% under the same circumstances. When the humidity level is increased to 85%RH, the aging behavior of both specimen types at 60°C is similar to that at RH=75% at both 60°C and 70°C. Under the aging conditions of 85%RH and 70°C, the strength of the joint collapses to zero for both specimen types during very short aging periods and at low static stressing levels (0-5% for the merely sand blasted specimens and 5-10% for the

silane pretreated specimens). The main reason for this behavior seems to be that the humidity level of 85% increases the water diffusion rate to the joint. Together with the temperature increase from 60°C to 70°C and the static loading, this increases markedly the aging rate and lowers both the threshold stress value and the durability of the joint.

9.4. Influence of joint protection on aging

Part of the merely sand blasted specimens were protected by applying a silicone layer to the joint edges. The aim of this protection was to prevent moisture from entering the joint and in that way to increase the durability of the joint. Figure 53 shows the residual strength values of the merely sand blasted and silicone protected specimens, when stressed at different loading levels under the aging conditions of 60°C and 75%RH. The results of these aging tests were compared to the results of merely sand blasted and unprotected specimens aged under the same conditions. According to the results, the silicone protection has no influence on the aging behavior of the sand blasted and acetone degreased specimens. There may be several reasons for that. It is possible that the silicone protection could not completely prevent the moisture from entering the joint. In addition, the silicone - base metal interface may not be fully impermeable to water vapor, especially in a stressed state. The silicone protection of the joint was abandoned from further tests, as it did not show any beneficial effect on the durability of the joint even under the mildest aging conditions used in this study.

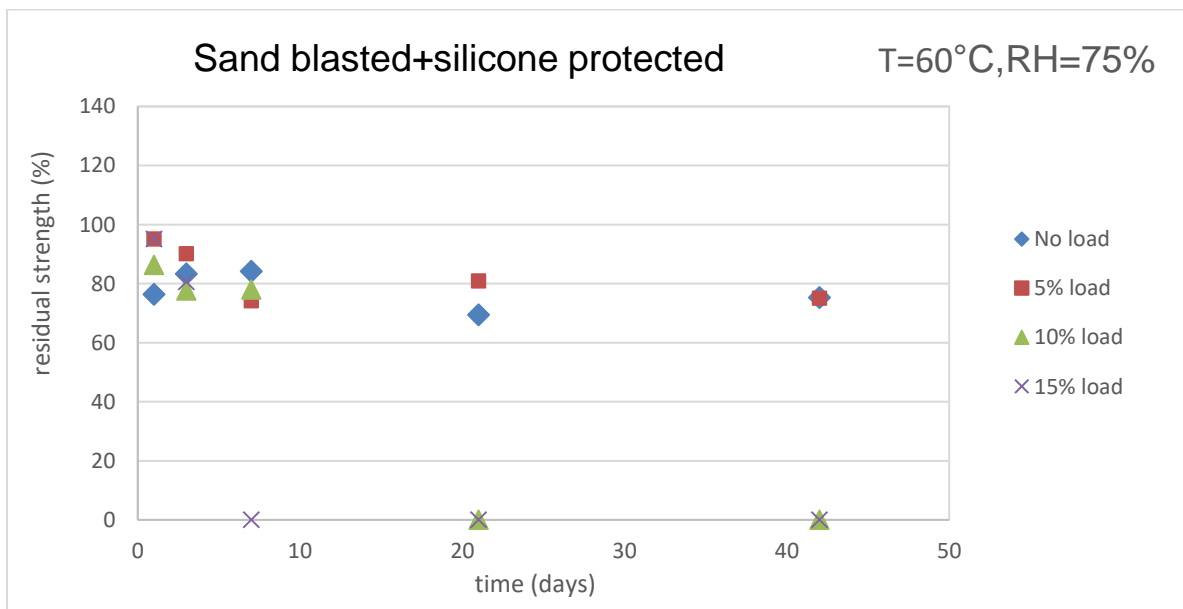

Figure 53. Residual strength values of the merely sand blasted and silicone protected specimens as a function of time when aged under 60°C and 75%RH at different stressing levels.

9.5. Reliability of the results

Several factors in the adhesive joining process may cause uncertainties and scatter in the aging test results. The age of the adhesive and the accuracy of the mixing ratio of the components are examples of the possible adhesive related sources of inaccuracy and uncertainty. The pretreatment methods also influence the accuracy of the results. In the sand blasting process, the grain size and the shape of the grains cause variations in the resulting surface topography and consequently in the results. Scatter in the results may also be caused by dirty adherend surfaces, and it is therefore most important to ensure the cleanliness of the surfaces before joining. Scatter in the results may also be caused by the different batches of the used adhesive, as well as the possible contamination of the surfaces after cleaning. When the adherend surfaces are chemically pretreated with silane, the age of the silane components, as well as the final amount of silane on the surfaces, may influence the results.

In the joining process, it is important to ensure that the adhesive is spread evenly over the entire joint area. Eventual variations in the thickness of the adhesive layer, as well as in the drying conditions, can also increase the scatter of the results

Variations in the aging conditions due to, e.g., intermittent device disturbances may also introduce unexpected variations in the results. Whenever large variations in the aging conditions were noticed during the aging tests of this study, those tests were discarded.

Uncertainties in the aging results may also be caused by the adjustment of the load level when compressing the springs. In shear tensile tests, the accuracy of the alignment of the specimens is important as the eventual misalignment introduces tear components in the joint stresses instead of pure shear. This may considerably lower the measured strength of the joint.

Due to the all above mentioned uncertainty factors, the characteristic scatter of the results in adhesive joining and joint testing tends to be quite large. Reduction of this scatter requires high carefulness in all stages of the joining, aging, and testing processes.

In the tests discussed in this thesis, the above-mentioned uncertainties were tried to be avoided or minimized as well as possible. Consequently, the presented test results seem to be quite reliable and their scatter is quite small for adhesive joining. To increase the reliability of the results, at least five repetitions for each test point were used. When calculating the averages of these five measurements, the noticed differences in the individual values were quite small. Figure 54 shows the highest, median, and lowest residual strength values of the sand blasted and silane pretreated specimens as a function of time when aged at the 15% loading level under the conditions of 60°C and 75%RH.

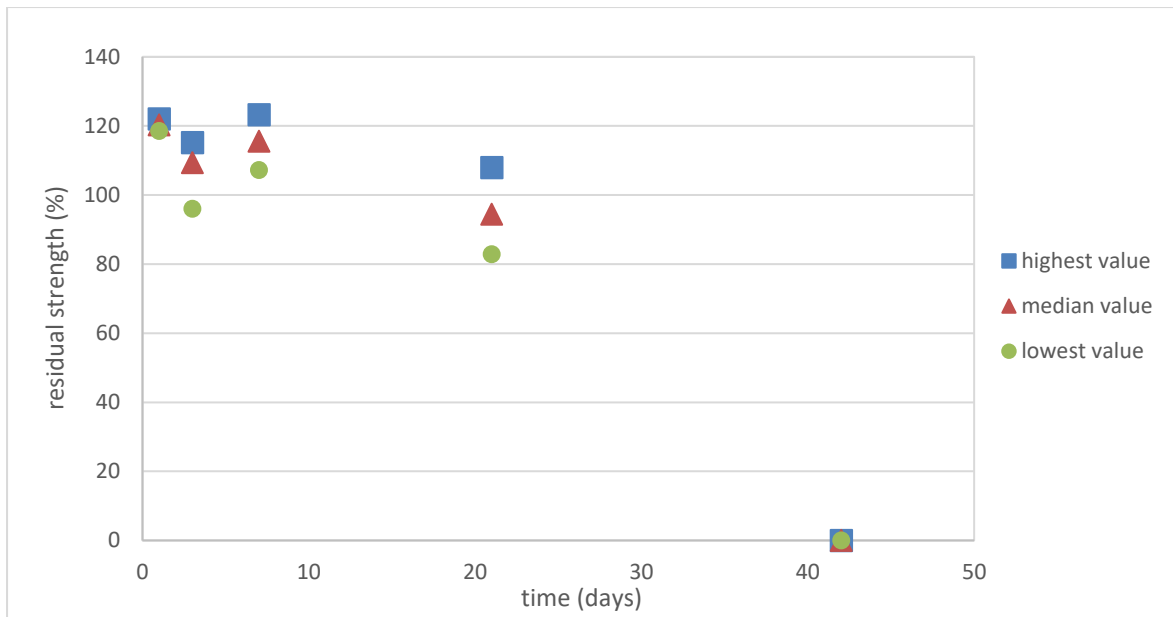

Figure 54. The highest, median, and lowest residual strength values of the five sand blasted and silane pretreated specimens aged under 60°C and 75%RH at the loading level of 15% of the original strength.

As Figure 54 shows, there are only small variations in the remaining strength values of the five individual tests for each exposure time up to three weeks of exposure. According to Figure 40, the strength of the sand blasted and silane pretreated specimens drops to zero between three and six weeks of exposure when aged at 60°C and 75%RH at the stressing level of 15%. This occurred for every specimen pretreated, aged, and stressed in this way. The scatter in the residual strength values of the five repetitions for each result point was the smallest with the sand blasted and silane pretreated specimens and for the milder aging conditions (low temperature, low humidity and low stressing level). The fracture was then also mainly of cohesive type. For merely sand blasted specimens, the scatter of the test results was slightly higher than for the sand blasted and silane pretreated specimens. Figure 55 shows the highest, median, and lowest residual strength values of the merely sand blasted specimens as a function of time when aged at the 15% loading level under the aging conditions of 60°C and 75%RH.

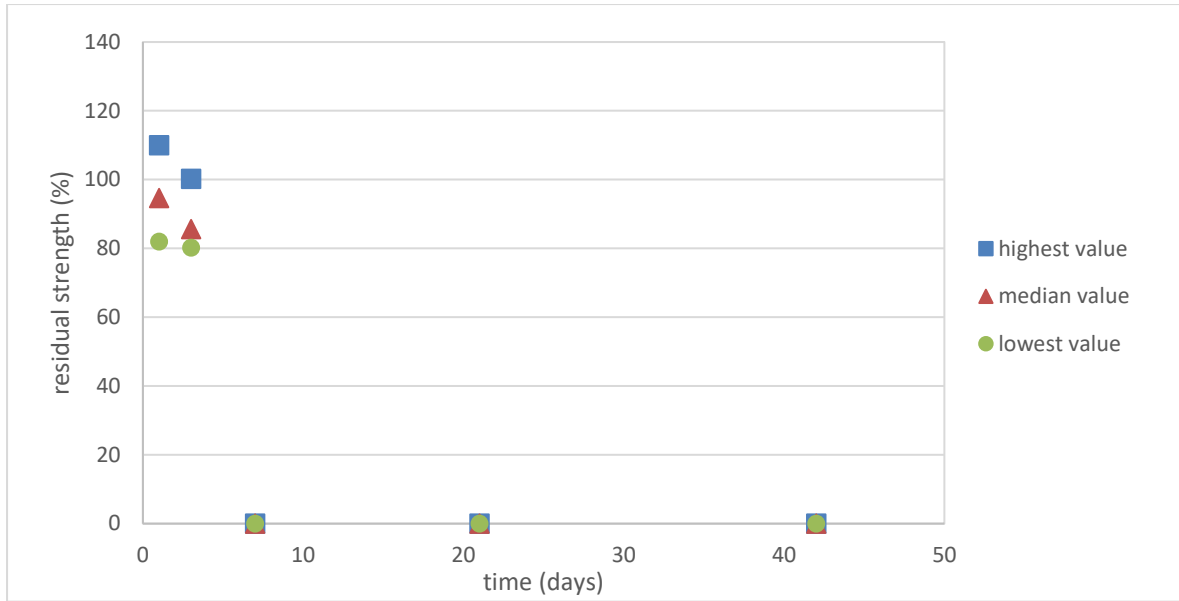

Figure 55. The highest, median, and lowest residual strength values of the merely sand blasted specimens as a function of time when aged under 60°C and 75%RH at the stressing level of 15% of the original strength.

10. CONCLUDING REMARKS

This chapter describes first the main scientific contributions of this study. The detailed conclusions drawn from the obtained results are then presented. The research questions set in the beginning of the work are revisited and the answers derived from the results are given.

10.1 Main scientific contributions of the study

The research work carried out and presented in this thesis yields new information on the aging behavior of epoxy-based aluminum adhesive joints. The combined effects of static loading, temperature, and relative humidity on the aging behavior are systematically studied for the first time in this work. The influence of the silane pretreatment of the adherend surfaces on the aging behavior is determined, and the changes in the joint fracture characteristics due to aging are explored.

The results reveal the existence of a specific threshold value for the static loading stress, above which the aging process is significantly accelerated and leads to rapid fracture of the joint. This threshold stress value depends on the severity of other aging conditions and decreases with increasing severity. In the studied aging parameter window, the threshold stress value varies between 0 and 15 % of the original unaged fracture strength of the joint.

The silane pretreatment of the adherend surfaces after sandblasting and degreasing increases the threshold stress value as compared with the pretreatment by only sandblasting and degreasing. Another beneficial influence of silane pretreatment is the shift of the initiation of accelerated aging and the consequent fracture towards longer times.

With propagating aging process, the fracture type of the joint in the post-aging tests changes from the initially fully cohesive fracture located in the adhesive towards an adhesive type of fracture along the interface between the adhesive and the adherend. The aging affects more the adhesive/adherend interface than the adhesive itself.

10.2 Detailed conclusions

Based on this study and the obtained results, the following conclusions can be drawn:

1. Adhesive joints suffer from aging when exposed to various environmental factors. In general, aging causes weakening of the joint, which can be detected as a decrease in the strength of the joint. Several environmental factors influence the aging of

adhesive joints. Temperature, humidity, and internal or external stresses are typically the strongest factors affecting the strength and durability of the joint.

2. This study on the behavior of epoxy-adhesive aluminum joints under combined aging environment and static loading is the first systematic exploration of the effects of static loading on the aging behavior of adhesive metal joints. It clearly reveals the effects of the studied three aging factors: temperature, humidity, and stressing level in the studied combinations on the durability and strength of the joint. The influence of the adherend surface pretreatment on the aging behavior and durability of the joint is also explored.

3. The aging of the joints was studied at the temperatures of 60°C and 70°C and at the relative humidity values of 75% and 85%. The used loading levels were 0, 5, 10 and 15% of the original fracture strength of the joints. The studied aging times were 1, 3, 7, 21 and 42 days. The studied adherend surface pretreatments included mere sand blasting + degreasing and sand blasting, degreasing + silane treatment.

4. Static loading changes radically the aging behavior and durability of the studied joints under the studied aging conditions. Joints that can endure aging without loading well can fail rapidly when aged under loading in the same aging conditions, even at low loading levels. One reason for this change in the joint behavior may be the enhanced diffusion rate of moisture into the joint and adhesive caused by the applied loading. The joint bonds stretched by the loading stress may also be more sensitive to the aging phenomena and deteriorate at a higher rate due to the enhanced penetration of moisture.

5. For all studied aging condition combinations, there seems to be a definite loading level above which the strength of the aging joint drops rapidly to zero after only a small reduction of the strength before that. Exceeding this threshold value of loading stress causes accelerated aging and catastrophic failure of the joint. The knowledge on the existence of such a threshold value of the loading stress under aging conditions is extremely important when designing the adhesively joined structures for aging environments. According to this study, the threshold stress value is quite low, varying between 0 and 15% of the original strength of the joint, depending on the severity of the aging conditions.

6. The threshold stress level is dependent on the pretreatment method and the severity of the aging conditions. In this study, it was noticed that under milder aging conditions and with efficient surface pretreatments, the threshold stress is between 10 and 15% of the original joint strength. More severe aging conditions and mere sand blasting as the surface pretreatment decreased the threshold stress level to between 0 and 5% of the original strength. Only the specimens that were not statically stressed under the studied aging conditions did not lose their strength even after longer aging periods.

7. Silane pretreatment of the adherend surfaces before joining increases the threshold stress level and enhances the durability of the joints. The threshold stress type

behavior is retained, but the catastrophic failure is transferred towards longer times due to the silane pretreatment. The beneficial influence of silane pretreatment diminishes at higher temperatures and humidity values.

8. The study of the fracture surfaces of the tested adhesive joints revealed the connection between the aging phenomena and the fracture type. The fraction of interfacial adhesive type of fracture increased when the aging temperature and humidity increased. The increase of humidity enhances the formation of adhesive type of fracture more than the increase of temperature in the studied aging condition window. The silane pretreatment together with sand blasting introduced and maintained the cohesive type of fracture except at the highest loading levels and humidity values. Mere sand blasting as a pretreatment method led more easily to the adhesive type of fracture even at lower loading levels and at lower temperature and humidity values. The fracture type studies supported the idea that the weakening of the joint is mainly due to the deterioration of the bonds between the adhesive and the adherend and not that much due to the weakening of the adhesive itself caused by moisture, temperature, and loading.

9. Unloaded and silane pretreated specimens endured well the studied aging conditions, and their fractures were mainly of cohesive type when tested after aging.

10. The eventual decrease of the glass transition temperature (T_g) of the adhesive due to its increased moisture content during aging may contribute to the reduction of the joint strength. Loading can accelerate the diffusion of moisture into the joint and consequently contribute to the more rapid strength reduction also via this mechanism.

10.3 Research questions revisited

From the results of the present study, the following answers to the research questions presented in the beginning of the work can be derived:

1. What are the combined effects of static loading and simultaneous environmental aging caused by elevated temperature and humidity on the durability of adhesive metal joints?

The answer to this research question was sought through a case study of epoxy-based aluminum adhesive joints. The static loading during the aging exposure accelerates the aging process. The results of this study verified that at least in the studied case there exists a specific threshold stress, above which the aging of the joint is strongly accelerated and leads to rapid strength loss and fracture of the joint. The threshold stress value decreases with increasing severity of the aging conditions. For the studied

joint types and aging parameter window, $T = 60 - 70$ °C and relative humidity R.H. 75-85 %, the threshold stress varied from 0 to 15 % of the original unaged strength of the joint.

2. How do the adherend pretreatment methods influence the strength and durability of adhesive metal joints exposed to different temperature and humidity conditions with and without static loading?

The results of this study on the epoxy-based aluminum adhesive joints show that the silane pretreatment of the adherends after sand blasting and degreasing enhances the durability of statically stressed specimens as compared with the pretreatment by mere sandblasting and degreasing. The silane pretreatment does not eliminate the presence of a specific threshold value for the loading stress, but it increases the level of the threshold stress under specific aging conditions and transfers the initiation of accelerated aging and rapid fracture towards longer aging times. Without loading, all the silane pretreated specimens endured the studied aging conditions for the maximum used aging time of 42 days without significant loss of strength.

The results of the present study, however, cannot be directly applied to other adherend/adhesive/pretreatment combinations of adhesive metal joints. The chemistry and other properties of the adhesive and pretreatment substances as well as the properties of the adherends influence strongly the resulting adhesion and durability of the joint. The results, however, do suggest that similar behavior could exist also for other adhesive metal joint types and give good reasons to carry out corresponding studies also for other joint types and their relevant aging conditions.

11. SUGGESTIONS FOR FURTHER RESEARCH

It is known that aging conditions such as high temperature, high humidity, and external or internal stresses may change the glass transition (T_g) temperature of the adhesive. Increasing humidity and temperature typically decrease the strength and durability of the joint, and together with simultaneous stress, the joint will weaken even more rapidly. The decrease of T_g due to moisture and stress will decrease the upper service temperature of the adhesive. If the T_g decreases below the actual service temperature of the joint, the strength loss might be severe and rapid. Therefore, it is important to know the influence and effects of the service conditions on the T_g of the used adhesive.

The eventual change of T_g due to the aging conditions can be evaluated by measuring the T_g before and after the aging periods. The role of T_g and its changes in the aging process should also be explored, e.g., by arranging the aging tests both well above and below T_g (taking into account the eventual changes in T_g).

The diffusion rate of water in the adhesive should also be studied both above and below the T_g of the adhesive, and the eventual effect of loading on the diffusion rate should also be measured. Tests should be carried out for each adhesive type due to the different types of chemistry of different adhesives. The aim of these measurements would be to reveal the eventual role of the T_g changes in the formation of the threshold stress.

Previous studies have shown that when exposed to high humidity and elevated temperatures, the strength of adhesive joints decreases first rapidly and then tends to level out. During the consequent exposure in dry conditions (50% RH or below), the strength of the joint may increase again. In the future, the effects of cyclic aging conditions (T , RH) as well as cyclic stresses on the aging process should be explored.

For the studied joint type, this thesis has verified the existence of a threshold stress value for the initiation of accelerated aging under constant aging conditions. The reasons and mechanisms for the formation of this threshold stress, however, still remain unknown. In the future, these reasons and mechanisms should be explored by trying to find out what happens to the individual bonds in the adhesive joints during aging and especially at the threshold stress value. Modeling of the adhesive joint aging processes on a statistical basis, for example by taking into account both the statistical distributions of individual bond strengths, intensity of the various aging factors, as well as the activation energy for bond breakage and their interactions during the aging process could yield much more understanding of this complex process.

12. REFERENCES:

- [1] Schultz, J. and Nardin, M. Theories and Mechanisms of Adhesion. In: Handbook of Adhesive Technology, Marcel Dekker Inc, New York, USA, (1994), pp. 19-33
- [2] Baldan, A. Adhesion Phenomena in Bonded Joints, International Journal of Adhesion & Adhesives vol 38 (2012), pp. 95-116
- [3] Comyn, J. Theories of Adhesion, Handbook of Adhesives and Sealants vol 2, Elsevier Ltd (2006), pp. 1-49
- [4] Lee, L-H. Recent Studies in Polymer Adhesion Mechanisms. In: Lee, L-H, (ed.) Adhesive Bonding, Plenum Publishing Corporation, New York, USA, (1991), pp. 1-30
- [5] Licari, J.J. and Swanson, D.W. Functions and Theory of Adhesives, Adhesives Technology for Electronic Applications, Elsevier Inc (2011), pp. 36-51
- [6] Hakala, K. Long-Term Durability of Adhesively Bonded Austenitic Stainless Steel Joint, Licentiate Thesis, Department of Materials Science, Tampere University of Technology, Tampere (2002)
- [7] Ebnesajjad, S. Theories of Adhesion. In: Surface Treatment of Materials for Adhesive Bonding, William Andrew Applied Science Publishers, 2nd ed. (2014), pp. 77-91
- [8] William Andrew Applied Science Publishers, Adhesive Bonding, Handbook of Plastics Joining, 2nd ed. (2009) pp. 145-173.
- [9] Ebnesajjad, S. Surface Tension and Its Measurement. In: Handbook of Adhesives and Surface Preparation: Technology, Applications and Manufacturing. William Andrew Applied Science Publishers (2011), pp. 21-30
- [10] Hämäläinen, A. Liimausprosessi ja liitosten pitkäaikaiskestävyys, M.Sc. Thesis, Department of Materials Science, Tampere University of Technology, Tampere (1997)
- [11] Davis, G.D and Kent, D. Shaffer, Durability of Adhesive Joints. In: Handbook of Adhesive Technology, Marcel Dekker Inc, New York, (1994), pp. 113-128
- [12] Brandon, D. and Kaplan, W.D. Joining Processes - An Introduction, John Wiley & Sons Ltd, England (1997), pp. 273-300

- [13] Adams,R.D., Comyn, J. and Wake, W.C. Structural Adhesive Joints in Engineering, Chapman&Hall, 2nd edition, UK, (1997) pp. 167-189
- [14] Messler, R.W. (Jr). Adhesive Bonding and Cementing. In: Joining of Materials and Structures, Elsevier Inc (2004), pp. 177-226
- [15] Petrie, E.M. Epoxy, Polyurethane, Acrylic, and Cyanoacrylate Adhesives. In: Handbook of Adhesives and Sealants 2nd edition, MCGraw-Hill, (2007), pp.1-64
- [16] Gauthier M.M In: Engineered Materials Handbook, Vol 3, Adhesives and Sealants, ASM International, USA (1990), pp. 74-93 (233)
- [17] Segure, D. M., Nurse, A.D., McCourt, A. Phelps, R. and Segura, A. Chemistry of Polyurethane Adhesives and Sealants. In: P. Cognar (ed.) Handbook of Adhesives and Sealants, Elsevier Ltd, (2005), pp. 101-162
- [18] Sadigh, M.A.S. Studying the Effect of Different Environmental Conditions on the Tensile Strength of RGO Reinforced Adhesively Bonded Butt Joints, Journal of Failure Analysis and Prevention (2016) 16, pp. 1134-1140
- [19] Vertuccio, L., Guadagno, L., Spinelli, G., Russo, S., Iannuzzo, G. Effect of Carbon Nanotube and Functionalized Liquid Rubber on Mechanical and Electrical Properties of Epoxy Adhesives for Aircraft Structures, Composites Part B 129 (2017), pp. 1-10
- [20] Dippel, B., Johliz, M. and Lion, A. Aging of polymer bonds: a coupled chemomechanical modelling approach, Continuum Mech.Thermodyn. (2014) 26, pp. 247-257
- [21] Atkins, T. and Batich, C. Environmental Stability of Polymers, MRS Bulletin (1993) September, pp. 40-44
- [22] Pethrick, R.A. Design and Aging of Adhesives for Structural Adhesive Bonding - A Rewiew, J Materials, Design and Applications (2015) 229(5), pp. 349-379
- [23] Baldan, A. Review Adhesively Bonded Joints in Metallic Alloys, Polymers and Composite Materials: Mechanical and Environmental Durability Performance, Journal of Materials Science (2004) 39, pp. 4729-4797
- [24] Minford, J.D. Durability Evaluation of Adhesive Bonded Structures. In: Lieng-Huang Lee (ed.) Adhesive Bonding, Plenum Publishing Corporation, New York, (1991), pp. 239-290

- [25] Sung, N-H. Moisture Effects on Adhesive Joints. In: Engineered Materials Handbook, Vol 3, Adhesives and Sealants, ASM International, USA, (1990), pp. 622-627
- [26] Comyn, J. Thermal Effects on Adhesive Joints. In: Engineered Materials Handbook, Vol 3, Adhesives and Sealants, ASM International, USA, (1990), pp. 616-621
- [27] Ruoranen, J. and Tiainen, T. Monitoring the Water Uptake Properties of Polyurethanes and Phenolics by Gravimetric Measurements. In: G.L.Anderson (ed), Proceedings of the AS Adhesion Society, Adhesion Science for the 21st Century, February 20-23, (2000) Myrtle Beach, South Carolina. The Adhesion Society, pp. 94-96.
- [28] Adams,R.D., Comyn, J., Wake, W.C. Structural Adhesive Joints in Engineering, Chapman&Hall, 2nd ed. UK, (1997), pp. 301-321 and 210-220
- [29] Hand, H.M., Arah, C.O., McNamara, D.K. and Mecklenburg, M.F. Effects of Environmental Exposure on Adhesively Bonded Joints, International Journal of Adhesion and Adhesives (1991), vol11, pp. 15-23
- [30] Hahn, O. and Yi, X.S. Ageing Behaviour of Bonded Metal Joints, Welding in the World (1987), vol 25, Great Britain, pp. 96-108
- [31] Ashcroft, I.A. and Comyn, J. Effects of Water and Mechanical Stress on Durability In: Lucas F.M.da Silva, Andreas Öchsner and Robert D.Adams (eds.). In: Handbook of Adhesion Technology, Springer-Verlag Berlin Heidelberg, (2011), pp. 790-822
- [31a] Berens, A.R. and Hopfenberg, H.B. Diffusion and Relaxation in Glassy Polymer Powders: 2. Separation of Diffusion and Relaxation Parameters, Polymer (1978) vol 19, pp. 489-496
- [31b] Carter, H.G. and Kibler, K.G. Langmuir-Type Model for Anomalous Moisture Diffusion in Composite Resins, Journal of Composite Materials (1978) vol 12, pp.118-130
- [31c] Loh, W.K., Crocombe, A.D., Abdel Wahab, M.M. and Ashcroft, I.A. Modelling Anomalous Moisture Uptake, Swelling and Thermal Characteristics of a Rubber Toughened Epoxy Adhesive, International Journal of Adhesion and Adhesives (25), (2005), pp.1-12
- [31d] Gledhill, R.A. and Kinloch.A.J. Environmental Failure of Structural Adhesive Joints, The Journal of Adhesion (1974) vol 6, pp.315-330

- [32] Yamabe, H. Influence of water on the Interface Properties. In: L.F.M da Silva and C.Sato (eds.) Design of Adhesive Joints Under Humid Conditions in Advanced Structured Materials, Springer e-books, (2013), pp. 95-111
- [33] Comyn, J. Interaction of Water with Epoxy Resins in Polymers In Marine Environment, (1989), pp. 153-159,
- [34] Zanni-Deffarges, M.P. and Shanahan, M.E.R, Diffusion of Water into an Epoxy Adhesive: Comparison between Bulk Behaviour and Adhesive Joints, International Journal of Adhesion and Adhesives (1995) vol 15, pp. 137-142, Great Britain
- [35] Sato, C. Influence of Water on the Adhesive Properties. In: L.F.M da Silva and C.Sato (eds) Design of Adhesive Joints Under Humid Conditions. In: Advanced Structured Materials, Springer e-books, (2013), pp. 77-93.
- [36] Lettieri, M. and Frigione, M. Effects of Humid Environment on Thermal and Mechanical Properties of a Cold-curing Epoxy Adhesive, Construction and Building Materials (30), (2012), pp. 753-760
- [37] Luo, S., Leisen, J. and Wong, C.P. Study on Mobility of Water and Polymer Chain in Epoxy and Its Influence on Adhesion, Journal of Applied Polymer Science (2002), vol 85, pp. 1-8
- [38] Mubashar, A., Ashcroft, I.A., Critchlow, G.W. and Crocombe, A.D. Moisture Absorption-Desorption Effects in Adhesive Joints, International Journal of Adhesion and Adhesives (2009), 29, pp. 751-760
- [39] Mora, V.B., Mieloszyk, M., Ostachowicz, W. Model of Moisture Absorption by Adhesive Joint, Mechanical Systems and Signal Processing, 99 (2018), pp. 534-549
- [40] Comyn, J., Diffusion of Water in Adhesives. In: L.F.M da Silva and C.Sato (eds) Design of Adhesive Joints Under Humid Conditions in Advanced Structured Materials, Springer e-books, (2013), pp. 1-20
- [41] Heshmati, M., Haghani, R., Al-Emrani, M. Effect of Moisture on the Long-term Performance of Adhesively Bonded FRP-Steel Joints Used in Bridges, Composites Part B 92 (2016), pp. 447-462
- [42] Savvilitidou, M., Vassilopoulos, A.P., Frigione, M., Keller, T. Development of Physical and Mechanical Properties of a Cold-curing Structural Adhesives in a Wet Bridge Environment, Construction and Building Materials 144 (2017), pp. 115-124

- [43] Pereira, A.M., Reis, P.N.B., Ferreira, J.A.M. and Antunes, F.V. Effect of Saline Environment on Mechanical Properties of Adhesive Joints, *International Journal of Adhesion and Adhesives* (2013), 47, pp. 99-104
- [44] Neve, B.D and Shanahan, M.E.R. Effects of Humidity on an Epoxy Adhesive, *International Journal of Adhesion and Adhesives* (1992), vol 12 no.3, pp. 191-196
- [45] Nogueira, P., Ramirez, C., Torres, A., Abad, M.J., Cano, J., Lopez, L., Lopez-Bueno, I. and Barral, L. Effect of Water Sorption on the Structure and Mechanical Properties of an Epoxy Resin System, *Journal of Applied Polymer Science* (2001), vol 80, pp 71-80
- [46] Neve, B.De. and Shanahan, M.E.R. Water absorption by an epoxy resin and its effect on the mechanical properties and infra-red spectra, *Polymer* (1993), vol 34, no 24, pp. 5099-5105
- [47] Han, X., Crocombe, A.D., Anwar, S.N.R., Hu, P. The Strength Prediction of Adhesive Single Lap Joints Exposed to Long Term Loading in a Hostile Environment, *International Journal of Adhesion and Adhesives* (2014) 55, pp. 1-11
- [48] Zheng, R., Lin, J.P., Wang, P-C. and Wu, Y-R. Effects of Hot-Humid Exposure on Static Strength of Adhesive Bonded Aluminium Alloys, *Defence Technology* (2015), 11, pp. 220-228
- [49] Pirondi, A., Nicoletto, G., Mixed Mode I / II Fracture Toughness of Bonded Joints, *International Journal of Adhesion & Adhesives* (2002) 22, pp. 109-117
- [50] Good, G. Combined Temperature-Moisture-Mechanical Stress Effects on Adhesive Joints. In: *Engineered Materials Handbook, Vol 3, Adhesives and Sealants*, ASM International, USA, (1990), pp. 651-655
- [51] Adams, R.D., Comyn, J., Wake, W.C. *Structural Adhesive Joints in Engineering*, Chapman&Hall, 2nd ed. (1997), pp.190-195
- [52] Landrock, A.H., *Surface Preparation of Adherends*. In: *Adhesive Technology Handbook*, Noyes Publications, New Jersey, (1985), pp. 54-83
- [53] Ebnesajjad, S. *Material Surface Preparation Techniques*. In: *Handbook of Adhesives and Surface Preparation*, Elsevier Inc, (2011), pp. 49-81
- [54] Adams, R.D., Comyn, J., Wake, W.C. *Structural Adhesive Joints in Engineering*, Chapman&Hall, 2nd ed, UK, (1997), pp. 245-289
- [55] Bishopp, J. *Surface Pretreatments for Structural Bonding*, In *Handbook of Adhesives and Sealants*, Elsevier Ltd, (2005), pp. 163-213

- [56] Baldan, A. Review Adhesively-Bonded Joints and Repairs in Metallic Alloys, Polymers and Composite Materials: Adhesives, Adhesion Theories and Surface Pretreatment, *Journal of Materials Science* (2004) 39, pp. 1-49
- [57] Boutar, Y., Naimi, S., Mezlini, S. Ali M.B.S. Effect of Surface Treatment on the Shear Strength of Aluminium Adhesive Single-lap Joints for Automotive Applications, *International Journal of Adhesion and Adhesives* 67 (2016), pp. 38-43
- [58] Ghumatkar, A., Sekhar, R., Budhe, S. Experimental Study on Different Adherend Surface Roughness on the Adhesive Bond Strength, *Materials Today: Proceedings* 4 (2017), pp. 7801-7809
- [59] Brack, N. and Rider, A.N. The Influence of Mechanical and Chemical Treatments on the Environmental Resistance of Epoxy Adhesive Bonds to Titanium, *International Journal of Adhesion and Adhesives* 48 (2014), pp. 20-27
- [60] Petrie, E.M. Adhesive Bonding of Aluminium Alloys, *Metal Finishing* (2007), pp. 49-56
- [61] Critchlow, G.W., Brewis, D.M. Review of Surface Pretreatments for Aluminium, *International Journal of Adhesion and Adhesives* (1996) vol 16, no 4, pp. 255-274
- [62] Prolonga, S.G., Urena, A., Effect of Surface Pretreatment on the Adhesive Strength of Epoxy-Aluminium Joints, *International Journal of Adhesion and Adhesives* 29 (2009), pp. 23-31
- [63] Saleema, N., Sarkar, D.K., Paynter, R.W., Gallant, D., Eskandarian, M. A Simple Surface Treatment and Characterization of AA 6061 Aluminium Alloy Surface for Bonding Applications, *Applied Surface Science* 261 (2012), pp. 742-748
- [64] Correia, S., Anes, V., Reis, L. Effect of Surface Treatment on Adhesively Bonded Aluminium – Aluminium Joints Regarding Aeronautical Structures 84 (2018), pp. 33-45
- [65] Walker, P. Silane and Other Adhesion Promoters. In: *Handbook of Adhesive Technology*, Marcel Dekker Inc, New York, (1994), pp. 47-63
- [66] Park, S.Y., Choi, W.J., Choi, H.S. A Review of the Recent Developments in Surface Treatment Techniques for Bonded Aluminium Airframe Structures, *International Journal of Adhesion and Adhesives* 80 (2018), pp. 16-29
- [67] Petrie, E.M. Silanes as Primers and Adhesion Promoters for Metal Substrates, *Metal Finishing* (2007), vol 105, n:o 7-8, pp. 85-93

- [68] Rider, A.N. Factors Influencing the Durability of Epoxy Adhesion to Silane Pretreated Aluminium, *International Journal of Adhesion and Adhesives* 26 (2006), pp. 67-78
- [69] Johnson, B., Olafsen, K., Stori, A., Vinje, K. Silanisation of Adhesively Bonded Aluminium Alloy AA6060 with γ -glycidyloxypropyltrimethoxysilane. I. Durability Investigation, *J.Adhesion Sci.Technol.* Vol16 no 14 (2002), pp.1931-1948
- [70] Del Real, J.C., Cano de Santayana, M, Abenor, J., Pantoja, M., Martinez, M.A. Influence of Silanisation Parameters with γ -methacryloxypropyltrimethoxysilane on Durability of Aluminium/Acrylic Adhesive Joints, *Journal of Adhesion Science and Technology* 22 (2008), pp. 1461-1475
- [71] Deflorian, F., Rossi, S., Fedrizzi, L. Silane Pretreatments on Copper and Aluminium, *Electrochimica Acta* 61 (2006), pp. 6097-6103
- [72] Abel, M-L., Allington, R.D., Digby, R.P., Porrit, N., Shaw, S.J., Watts, J.F. Understanding the relationship between silane application conditions, bond durability and locus failure, *International Journal of Adhesion and Adhesives* 26 (2006), pp. 2-15
- [73] Pantoja, M., Abenojar, J., Martinez, M.A., Velasco, F. Silane Pretreatment of Electrogalvanized Steels: Effect on Adhesive Properties, *International Journal of Adhesion and Adhesives* 65 (2016), pp. 54-62
- [74] Broad, R., French, J., Sauer, J. New, Effective, Ecological Surface Pretreatment for Highly Durable Adhesively Bonded Metal Joints, *International Journal of Adhesion and Adhesives* 19 (1999), pp. 193-198
- [75] Sauer, J. Surface Treatment, Patent, WO 96/23037, (1996)
- [76] French, A. and Broad, R. Surface Treatment, Patent, WO 99/37830, (1999)
- [77] Rechner, R., Jansen, I., Beyer, E. Influence on the Strength and Aging Resistance of Aluminium Joints by Laser Pretreatment and Surface Modification, *International Journal of Adhesion and Adhesives* 30 (2010), pp. 595-601
- [78] Spadaro, C., Sunseri, C., Dispenza, C. Laser Surface Treatment for Adhesion Improvement of Aluminium Alloys Structural Joints, *Radiation Physics and Chemistry* 76 (2007), pp. 1441-1446
- [79] Baburaj, E.G., Starikov, D., Evans, J., Shafeev, G.A., Bensaoula, A. Enhancement of Adhesive Joint Strength by Laser Modification, *International Journal of Adhesion and Adhesives* 27 (2007), pp. 268-276
- [80] Hernandez, E., Alfano, M., Lubineau, G., Buttner, U., Improving Adhesion of Copper/Epoxy Joints by Pulsed Laser Ablation, *International Journal of Adhesion and Adhesives* 64 (2016), pp. 23-32

- [81] Rotella, G., Alfano, M., Schiefer, T., Jansen, I. Enhancement of Static Strength and Long term Durability of Steel/Epoxy Joints through a Fiber Laser Surface Pretreatment, *International Journal of Adhesion and Adhesives* 63 (2015), pp. 87-95
- [82] Chiudo, G., Alfano, M., Pini, S., Pirondi, A., Furgiele, F., Groppetti, R. On the Effect of Pulsed Laser Ablation on Shear Strength and Mode I Fracture Toughness of Al/Epoxy Adhesive Joints, *Journal of Adhesion Science and Technology*, vol 29, no 17 (2015), pp. 1820-1830
- [83] Mandolino, C., Lertora, E., Genna, S., Leone, C., Gambaro, C. -Effect of Laser and Plasma Surface Cleaning on Mechanical Properties of Adhesive Bonded Joints, *Procedia CIRP* 33 (2015), pp. 458-463
- [84] Saleema, N., Gallant, D. Atmospheric Pressure Plasma Oxidation of AA6061 – T6 Aluminium Alloy Surface for Strong and Durable Adhesive Bonding Applications, *Applied Surface Science* 282 (2013), pp. 98-104
- [85] Ruorananen, J., Tiainen, T., The Influence of Surface Pretreatments on the Strength of Epoxy – based Adhesive Aluminium Joints under Combined Static Loading and Environmental Aging Conditions, *CD Proceedings of the 9th European Adhesion Conference EURADH*, September 16-20, (2012), Friedrichshafen, Germany, pp 1-6
- [86] Huntsman, Araldite 2014 A/B product datasheets, (2006)
- [87] EVONIK Industries, Dynasylan Product Range brochure, The Global Brand for Organofunctional Silanes. (2011)
- [88] EVONIK Industries, Technical Information 1408, Dynasylan Primers; Examples for the Formulation of Silane Primers for Paints and Coatings, (2011)
- [89] ASTM D 1002-72, Standard Test Method for Strength Properties of Adhesives in Shear by Tension Loading (Metal to Metal). (1983)
- [90] ASTM D 2919-90, Standard Test Method for Determining Durability of Adhesives Joints Stressed in Shear by Tension Loading. (1990)

Tampereen teknillinen yliopisto
PL 527
33101 Tampere

Tampere University of Technology
P.O.B. 527
FI-33101 Tampere, Finland

ISBN 978-952-15-4206-0

ISSN 1459-2045