



TAMPERE UNIVERSITY OF TECHNOLOGY

**SACHIN NAYAK**  
**SOFTWARE AND HARDWARE VARIATION IN SYMBIAN**  
**CAMERA SYSTEM**

Master of Science Thesis

Examiners:  
Professor Jarmo Harju (TUT)  
M.Sc. Henri Puhto (Nokia Oyj)

Examiner and topic approved in the  
Faculty of Computing and Electrical  
Engineering Council meeting on  
7<sup>th</sup> December 2011

## ABSTRACT

TAMPERE UNIVERSITY OF TECHNOLOGY

Master's Degree Programme in Information Technology

**NAYAK, SACHIN: Software and hardware variation in Symbian camera system**

Master of Science Thesis, 51 pages

May 2012

Major: Communications Engineering

Examiners: Professor Jarmo Harju, M.Sc. Henri Puhto

Keywords: Software variation, configuration, mobile device, camera system, Symbian OS

During the past decade, multimedia features in mobile phones have become common. Even the low-end category mobile phones are equipped with camera in order to capture digital images and record videos. Mobile phones are giving tough competition to stand-alone camera devices by providing quality imaging experience to the consumers. In order to lead and compete with the pack of global mobile device manufacturers, Nokia has to differentiate its mobile device offerings across the wide price range addressing different market requirements. This necessitates them to use different types of cameras and flash hardware modules across their mobile phone range resulting in different camera system configurations. To support the range of mobile phones with a single software operating system platform, effective software variation is required.

Some of the possibilities with mobile phone camera system configurations are devices equipped with one or two camera modules along with multiple or no flash HW, camera sensors with resolutions ranging from VGA to 41 megapixels, camera modules with autofocus or fixed focus lenses, flash modules based on Xenon or LED technology and the camera system controlled by either application processor or dedicated image signal processor. Symbian OS is the software platform capable of supporting various Nokia mobile devices with different hardware configurations. This is possible due to extensive software variation mechanisms that the Symbian OS supports.

This thesis is an effort in describing various camera system configurations within the Nokia Symbian mobile phones and the software variation being used in supporting those.

## **PREFACE**

This thesis has been written while working in Symbian Devices Imaging organization, first as a part of Nokia Oyj and later Accenture Services Oy, in Tampere, Finland.

I would like to thank my colleagues in the Imaging organization for creating an encouraging and inspiring atmosphere. Special thanks to Henri Puhto for suggesting the subject matter for the thesis, for providing his time, effort and patience in supervising this work and for guiding me throughout the process. Thanks to my manager Petri Soininen from Nokia Oyj for his encouragement and valuable comments on my work. I am thankful to Professor Jarmo Harju for guiding my work with his valuable suggestions and review comments.

Last but not the least, thanks to my family for their continuous support and encouragement.

Tampere 23<sup>rd</sup> April 2012

SACHIN GAJANAN NAYAK

## CONTENTS

1	Introduction.....	1
2	Camera System .....	2
2.1	Digital Imaging System .....	2
2.1.1	Optics.....	3
2.1.2	Image Sensor .....	4
2.1.3	Flash.....	5
2.1.4	Imaging Pipe in a Mobile Device .....	6
2.2	Nokia Camera Phones.....	7
2.3	Camera and Flash Hardware.....	8
2.3.1	Camera Modules .....	9
2.3.2	Application Processor Engine.....	10
2.3.3	Imaging and Video Engine .....	11
2.3.4	Flash Module & Privacy Indicator .....	11
2.3.5	Flash Driver .....	11
2.4	SMIA (Standard Mobile Imaging Architecture).....	12
3	Symbian OS .....	13
3.1	Introduction to Symbian OS .....	13
3.2	The Scope of Symbian OS.....	14
3.3	Dynamically Loadable Components.....	14
3.3.1	DLL Entry Points.....	14
3.3.2	Static Interface DLLs.....	15
3.3.3	Polymorphic Interface DLLs .....	15
3.3.4	Symbian ECom Architecture .....	15
3.4	The Software Architecture of Symbian OS .....	16
3.4.1	UI Framework.....	17
3.4.2	Application Services .....	18
3.4.3	Java ME .....	18
3.4.4	OS Services.....	18
3.4.5	Base Services .....	19
3.4.6	Kernel Services & Hardware Interface.....	19
3.5	Camera and Video System Architecture.....	19
3.5.1	Camera Driver .....	19
3.5.2	Multimedia Framework .....	20
3.5.3	Image Conversion Library .....	21
3.5.4	Onboard Camera API .....	21
3.5.5	Camera APP Engine .....	22
3.5.6	Camera Application .....	22

4	Software variation.....	23
4.1	Production Line Engineering .....	23
4.2	Software Variation in Production Line Engineering .....	24
4.3	Variation Point.....	25
4.3.1	Types of Variation Points .....	25
4.3.2	Variation Points in Symbian Platform SW .....	26
4.4	Software Variation Methods in Symbian OS .....	27
4.4.1	Software Build System for Symbian OS .....	27
4.4.2	Feature Flag Settings .....	29
4.4.3	Feature Discovery API .....	30
4.4.4	Central Repository .....	31
4.4.5	Dynamic Configuration Files .....	32
5	Variation in Camera system.....	33
5.1	Purpose for Variation.....	33
5.2	Camera and Flash Hardware Configurations.....	33
5.2.1	Single Processor Configuration .....	34
5.2.2	Multi Processor Configuration .....	35
5.2.3	System on Chip Configuration .....	36
5.2.4	Types of Camera and Flash Modules .....	36
5.3	Variation with Camera Application.....	37
5.4	Variation with Onboard Camera API .....	38
5.5	Variation in Camera Driver .....	40
5.5.1	Flash Module Specific Flags .....	40
5.5.2	Flags for Configuring Primary Camera .....	40
5.5.3	Flags for Configuring Secondary Camera .....	41
5.5.4	Algorithm Specific Configuration Flags .....	42
5.6	Case Study with Symbian^3 Products .....	42
6	Conclusion .....	49
	References .....	50

## TERMS AND ABBREVIATIONS

APE	Application Processor Engine
API	Application Programming Interface. An interface that specifies the functionality and usage of the underlying software component.
ARM	Advanced RISC Machines
ASIC	Application-Specific Integrated Circuit
CCD	Charge Coupled Device
CMOS	Complementary Metal Oxide Semiconductor
DSC	Digital Still Camera
DSP	Digital Signal Processor
DLL	Dynamic Link Library
EDoF	Extended Depth of Field
GUI	Graphical User Interface
HW	Hardware
IQ	Image Quality
ISP	Image Signal Processor. A hardware component that offers image and video processing capability.

IVE	Imaging and Video Engine; HW accelerator for camera, flash and optionally display.
JPEG	Joint Photographic Experts Group. A lossy compression method used for multiple image file formats.
LDD	Logical Device Driver
MMF	Multimedia Framework
OS	Operating System
PDD	Physical Device Driver
Raw Bayer	An uncompressed image format where the information from the image sensor is not processed.
RISC	Reduced Instruction Set Computer
ROM	Read Only Memory
SW	Software
VGA	Video Graphics Array. 680x480 resolution.
YUV	A color space and compressed image format, which separates the luminance and chrominance components from the image information.

# 1 INTRODUCTION

Camera is nowadays a de facto component in mobile phones, whether they are the lowest or the highest end devices. Mobile phones are the primary camera devices for most of the users and for many the only camera that they use. The industry has shipped 3.8 Billion camera phones in the past 9 years and 2.5 Billion of those camera phones are still in use today. Nokia's installed base of camera phones in use is about 1 Billion. From 2004 the world's best-selling camera brand including all film based and digital cameras has been Nokia. The world's biggest optical camera lens makers today are Carl Zeiss optics, as they are on many premium Nokia camera phones [3].

According to Gartner [1], 37.6% of smart phones sold to end users in 2010 were running on Symbian Operating System. The Symbian OS, uniquely designed with smartphones in mind, offers a host of experiences that consumers demand today, multiple home screens, gesture interaction, visual multitasking so on and so forth. The Symbian platform offers the flexibility to scale and extend smartphone features to lower price points. Majority of Nokia mobile phones run on Symbian OS.

'One size does not fit all.' Nokia, the leading mobile phone manufacturer has a device portfolio that caters different market needs at wider price range. Nokia procures variety of camera hardware from different vendors for the mobile phone camera system. The camera system in a mobile phone may include two or single camera modules with multiple or no camera flash hardware. The camera module may contain an autofocus lens with optical zoom or may have a fixed focus lens with digital zoom. Camera modules could have camera sensors with the resolution that ranges from 0.3 to 41 mega pixels. Mobile phones could utilise its application engine processor or a stand-alone processor to execute the camera system specific tasks. The camera system software may support several camera features like red-eye-removal, face detection, auto exposure, auto focus, auto white balance to enhance the captured images and videos. In order to handle a variety of camera setups and to differentiate several features as described above, an efficient variation mechanism is required in the phone software. This thesis concentrates on Nokia Symbian platform for mobile phones and in the camera system variation within those phones.

This thesis begins by describing the camera system in Chapter 2. Chapter 3 gives an overview of the Symbian OS. Chapter 4 describes the software variation and the variation mechanisms in Symbian OS. Chapter 5 illustrates the variation points within the camera system and the Chapter 6 draws the conclusions from this study.



## 2 CAMERA SYSTEM

This chapter provides introduction to the optics, image sensors, flash and to the whole camera system used in mobile devices.

### 2.1 Digital Imaging System

Consumers have been enjoying digital imaging since 1995 when the first consumer digital still camera, Casio QV-10 was made available in market [15 p.9]. During last 15 years digital imaging has generalized and markets for digital still cameras (DSC) have grown rapidly. In addition to DSCs, digital imaging technologies have become common in multiple other applications such as mobile phones, web cameras, medical imaging and surveillance systems.

Optics (lens system), an image sensor, a processor and a flash as demonstrated in Figure 2.1 form the digital imaging system. On capturing an image, the object is first illuminated by the scene lighting or by the flash. The object reflects light back to the camera lens. The lens focuses the light from the object on the sensor of the camera which converts the light into electrical signals. The electrical signals are transferred to the imaging processor which generates the image and sends the image to the display of the device and to the file system for storing purposes. The main components of the digital imaging system are explained in the following sub sections.

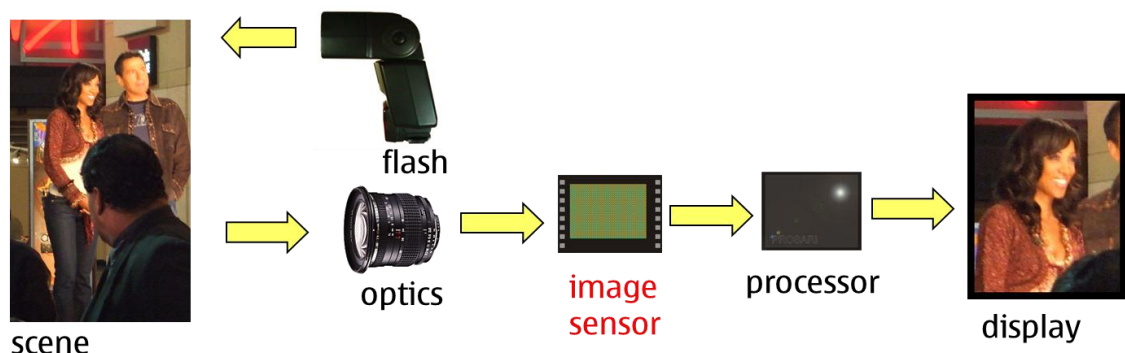

Figure 2.1: A digital imaging system [19]

### 2.1.1 Optics

In digital imaging, an optical system controls the light entering the imaging device. The optical system includes lenses, filters and an aperture as demonstrated in Figure 2.2. The main function of these parts is to provide a sufficient amount of light entering the camera and to make sure that the object appears sharp and detailed, i.e. focused.

The focusing capability of the optical system is mainly dependent on the focal length of the system. A lens refracts light rays and forms an image of the object that appears to be sharpest at the focal point of the optical system. Focal length is the distance from the formed image, i.e. the focal point, to the lens when the object is at infinity and the optical system is only a single thin lens [16, p.39]. Focal length depends on the shape of the lens, where a convex lens has positive focal length and a concave lens has a negative focal length [16, p.40]. The number of lenses present in the system also affects it. Focal length is used to measure how effective an optical system is to disperse or gather light rays. Short focal length means strong refractive power as long focal length means weaker refractive power [15, p22-p24] .

An aperture is the opening of the optical system defining how much light enters to lenses and how collimated the light rays are. Focal length and aperture define the depth of field of the optical system. Depth of field is the depth within which the object appears to be in focus [15, p.32-33]. The smaller the aperture or the shorter the focal length, the larger the depth of field. In mobile phone cameras, a small aperture and short focal length are used, providing a large depth of field [17].

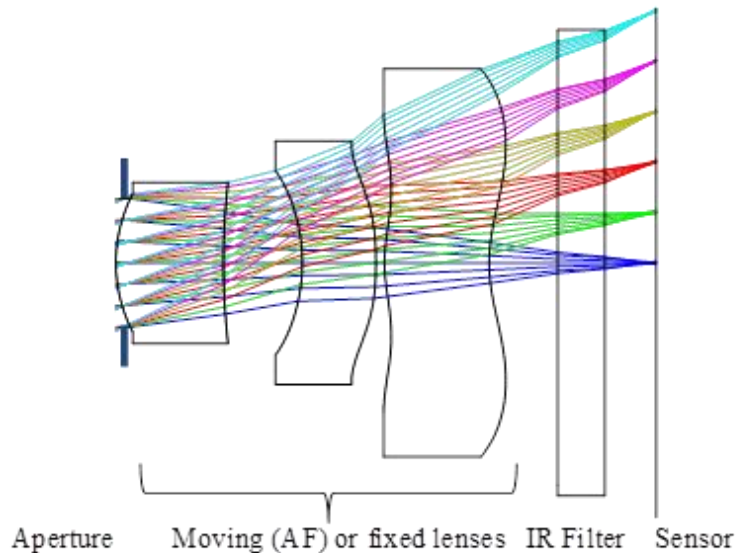

Figure 2.2: A typical mobile phone camera lens system [17]

To reach the optimal focus for each use case, there are several optical solutions used in mobile phone cameras. Fixed focus cameras include an optical system where the lenses are stationary and aperture diameter is constant, thus providing fixed focal length and depth of field. This means that lenses are typically stationed so that the object appears to be in focus from the distance of 30cm to infinity.

Automatic focus (AF) cameras are used when it is required to be able to focus to near distances (macro photography) or otherwise alter the focal length and the depth of field. AF cameras use electrical motors to alter the distance of the lenses and the size of the aperture enabling focusing to as near as 10cm from the object. AF is the most sophisticated solution, which provides the best image quality, but with a higher price tag and larger physical size of the system. Larger size of the camera module throws challenge for the mobile phone design as the devices are expected to be thin and sleek.

Extended depth of field (EDoF), also known as digital focus, cameras use signal processing software to reach fixed focus from the distance of even 10cm to infinity without moving the lenses. This digital focusing offers a cost effective solution to reach a large depth of field, often with the expense of the image quality in macro mode image captures. Physical size of the camera module with this solution tends to be smaller than modules with AF lens.

### 2.1.2 Image Sensor

An image sensor is a light-sensitive semiconductor device that converts the image formed by the lens into electrical signals [15, p.54]. This is called a photo conversion, and it takes place in the pixels from which the image sensor is formed. A pixel is sensitive to photons and it is capable of transforming the energy of photons into electrical voltage (photo conversion). A photon is a particle that contains a small amount of energy (approximately 2eV with the wavelength of 600nm) and has a wavelike behavior. Visible light consists of photons. However, to be able to produce a visible image for the human eye, only photons with wavelengths from 380nm to 780nm are allowed to enter the pixels of the image sensor [15, p.54].

Photons entering the sensor are filtered with a red, green and blue (RGB) color filter array. It is named after the colors, or wavelengths, that it passes through. The most commonly used pattern for color filters is the Bayer pattern, which includes two green filters for every red and blue ones. Each pixel has a color filter for one RGB color, thus mapping the size of the color filter array to the actual amount of pixels on the sensor. The Bayer color filter array along with the structure of a pixel is demonstrated in Figure 2.3. Along with the color filter array, there is also an infrared (IR) filter and a neutral density (ND) filter in the camera system. The IR filter typically filters wavelengths from 680nm to 900nm to reduce thermal noise, since pixels are very sensitive to IR wavelengths [16, p.24]. ND filter filters all wavelengths equally to control the exposure time [16, p.24].

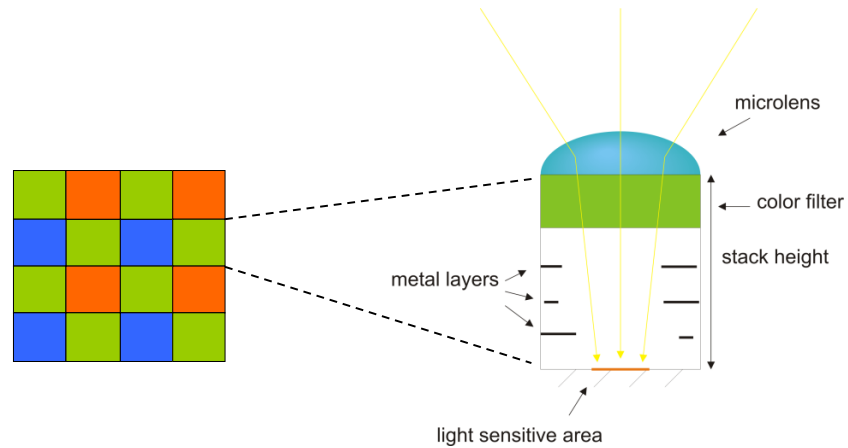

Figure 2.3: The Bayer color filter pattern and the structure of a pixel [17]

When taking digital images, the exposure time defines how long the pixels on the image sensor are able to gather photons and thus accumulate charge. The brighter the conditions, the shorter the exposure time. After the exposure the charge is transferred from each pixel by scanning the whole sensor array. When the scanning is completed the image is formed on the image sensor and is ready to be processed further.

There are two different types of image sensor technologies used in mobile phone digital cameras: charge-coupled device (CCD) image sensors and complementary metal oxide semiconductor (CMOS) image sensors. The two types differ in the transistor technology used in the pixels and how the pixel scanning is performed.

The resolution of image sensors varies from the low end of 0.3 megapixels (million pixels) to the high end of 12 megapixels. These high image resolutions have been enabled by the reduction of pixel sizes. Currently the pixel size in the high-resolution image sensors can be as small as 1.75 $\mu\text{m}$  or even less [17]. Although high resolutions offer larger and more detailed images, the small pixel size can be a problem since the smaller the pixel, the less it is capable to detect light. This leads to longer exposure times in low light conditions, thus causing motion blur to the images, and slower sensor readout speeds compared to lower resolution image sensors.

### 2.1.3 Flash

The image sensor detects reflected light from the object that is being photographed. This provides a challenge when light is not sufficient. To be able to capture decent quality images in low light conditions camera system can be equipped with a flash. A flash is an artificial light source that can illuminate close range objects thus providing sufficient lighting to capture images.

Mobile device cameras exploit two different flash technologies: the light emitting diode (LED) and Xenon. LED is a semiconductor material that converts electrical energy into light [17]. LED flash has good efficiency but it is not very powerful and does not produce very natural light. Xenon flash is named after the inert gas that it uses to

produce a short and bright light burst [17]. Xenon flash requires capacitors with large physical size for holding electric charge needed to fire the flash. It is capable of emitting very natural color temperature range. LED flash technology is cheaper to manufacture, smaller in physical size and more common in mobile devices than Xenon flash technology.

#### 2.1.4 Imaging Pipe in a Mobile Device

In a mobile device, the lens system and the image sensor are both located in a camera module. The camera module also includes a shutter, a focusing mechanism (fixed focus, AF or EDoF) and an AD-converter, which transforms the analog electrical signals from the image sensor into digital image data. The camera module is connected to the rest of the imaging pipe with a control bus and a data bus. This is presented in Figure 2.4, which illustrates a simplified block diagram of an imaging pipe in a mobile device. Imaging pipe is a concept that means all the hardware and software components involved in the image reconstruction.

The camera interface is the component that controls the imaging sensor in the camera module and receives image data in Raw Bayer format via a data bus. The camera interface component may perform image-processing operations to the image data depending on the prevailing camera settings. It also adds meta data to provide required information about the image to other components in the imaging pipe. The camera interface component can convert the image data into YUV format for viewfinder purposes and sends it to the display component.

The still image data is sent to the Image Signal Processor (ISP) component in Raw Bayer format that performs more image processing. ISP is generally a set of HW blocks that has the capability to correct defect pixels, to compensate lens shading, to correct white balance and to remove noise from the raw image data itself. Further, it transforms the corrected image data to YUV format and performs extensive image processing to enhance the captured image. This includes for example color correction, sharpening and gamma correction. Several of these ISP functional blocks for filtering, correcting and formatting the image data are configurable by SW. ISP can process the image data simultaneously in several blocks at the same time. ISP must be efficient to handle the increasing image sensor resolutions and bus frame rates with still and video capture. Thus, ISP is an important component from the image quality perspective.

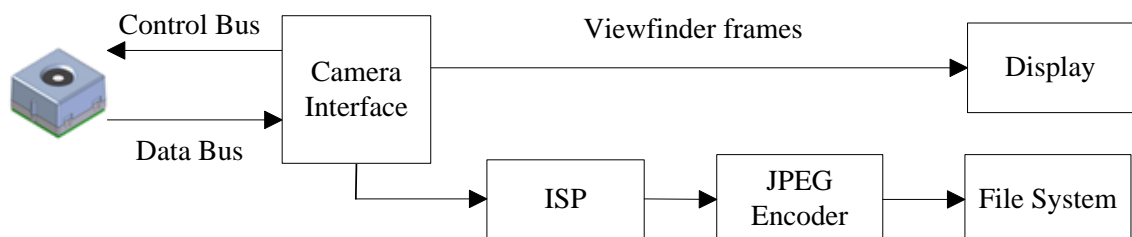

Figure 2.4: Block diagram of mobile phone imaging pipe

The resulting YUV image from the ISP needs to be compressed so it is transferred to the JPEG encoder component. The JPEG encoder encodes the image into JPEG format and transfers it to the file system. This is a basic example on how the imaging pipe functions in the still imaging use case in a mobile device.

## 2.2 Nokia Camera Phones

Camera phones are not just improving on the sensors and resolutions, they are also improving on the lenses, flashes, focusing capabilities and zooming capabilities too. We are witnessing today the usage of xenon flash, dual-LED flash, carl-zeiss lens on camera phones. What makes the camera phones unique is the convergence. Camera phone hardware is surpassing the hardware specifications of stand-alone digital cameras. With the increased availability of raw processing power, location-awareness, vibrant and bright touchscreen displays, today's camera phones are equipped to handle blink-detection, face-detection, smile-detection, touch-focus (ability to focus on a particular spot on the frame by just tapping the touch-screen), geo-tagging (GPS capabilities), image stabilizer, video stabilizer, high quality image resolutions and HD quality video recording capabilities.

Nokia 7650 and Nokia N8 are two milestones in the Nokia's Symbian smartphones league. Nokia 7650 was the first Nokia camera phone running Symbian OS that had a VGA camera. N8 is one of the latest additions that has a 12 megapixel main camera with Xenon flash and a VGA front camera for video calling.



Figure 2.5: Nokia 7650 and Nokia N8 smart phones [4]

Year	Phone Model	Camera System Specification & Symbian platform
2002	Nokia7650	0.3MP(megapixels)(VGA-640x480); Symbian OS V 6.1; First Series 60 (S60) platform device; first Nokia with built-in camera.
2004	Nokia6630	1.3MP (1280x960) & Video Calling; Symbian OS v8.0a + S60 2nd Edition
2005	Nokia N70	2MP main & 0.3MP second camera; Symbian OS v8.1a, S60 Second Edition, Feature Pack 3.
2005	Nokia N90	2MP, Carl Zeiss optics, Autofocus LED flash & Video calling; Symbian OS v8.1a, Series 60 2nd Edition, Feature Pack 3.
2006	Nokia N73	3.2MP (Carl Zeiss Tessar Lens with Autofocus and 20x digital zoom) 640x480 VGA second camera with 2x digital zoom; Symbian OS v9.1, S60 3rd Edition.
2006	Nokia N95	5MP (Carl Zeiss optics autofocus, LED Flash) CIF Video call second camera; Symbian OS v9.2, S60 3rd Edition.
2007	Nokia N82	5MP Carl Zeiss optics, autofocus and Xenon flash, CIF Video call on second camera; Symbian OS v9.2, S60 3rd Edition Feature Pack 1.
2008	Nokia 5800 XpressMusic	3.2MP, Carl Zeiss optics with autofocus and dual LED flash, 3x digital zoom and geotagging support. VGA second camera for video calls; Symbian^1/S60 5.0 platform
2009	Nokia N86	8MP with 28mm wide camera lens, VGA video call on second camera; Symbian OS 9.3, S60 rel. 3.2.
2009	Nokia N97	5.0MP f/2.8 Carl Zeiss Tessar lens, VGA video call on second camera; Symbian^1/S60 5.0 platform.
2010	Nokia N8	12MP Carl Zeiss optics and Xenon flash, VGA video call on second camera. Runs Symbian^3.
2011	Nokia C7	8MP EDoF camera with LED flash, VGA video call on second camera; Symbian^3.
2012	Nokia 808 PureView	41MP AF camera with Nokia Pureview Pro imaging technology and Carl Zeiss optics, Xenon Flash, VGA video call on second camera. Runs Symbian^3

Table 2.1: Nokia Phones Camera specification and Symbian platforms [12].

Table 2.1 lists some of the key Nokia Symbian phones with their camera specifications to illustrate the evolution of camera system.

### 2.3 Camera and Flash Hardware

For mobile phone manufacturers, camera and flash hardware is important differentiating factor in their offerings. This hardware setup typically consists of camera modules, flash

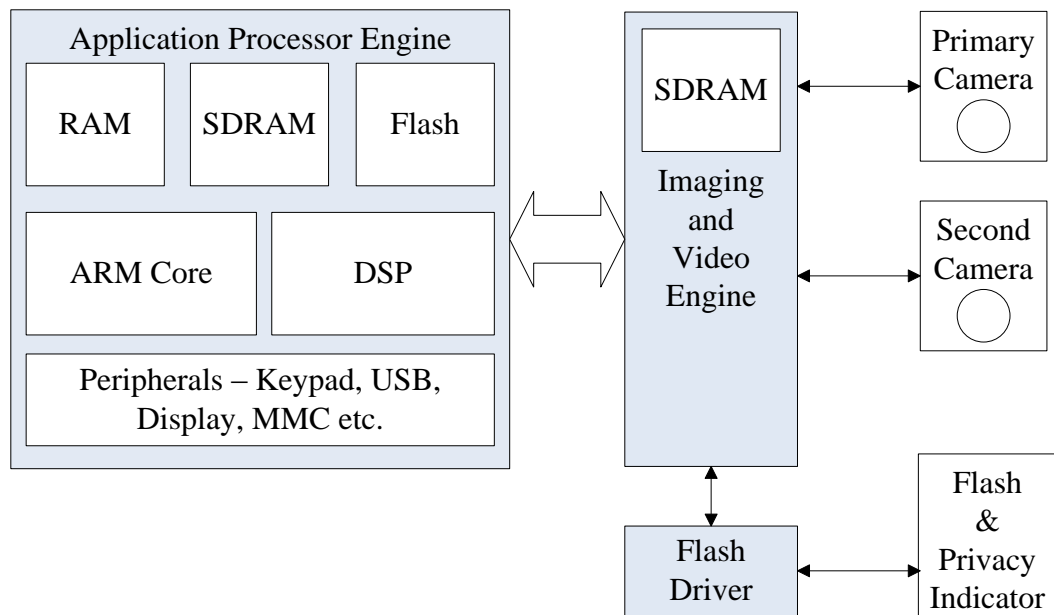

Figure 2.6: A typical camera HW setup in Nokia Symbian phones

modules and at least one processor. Figure 2.6 shows the typical hardware setup in a Nokia smart phone. Following sub-sections explain each of these modules from the setup.

### 2.3.1 Camera Modules

Most of the Nokia phones are shipped with two cameras: a higher resolution camera module as the primary camera for the image and video capture and often a front facing VGA camera as secondary camera mainly used for video calling. Figure 2.7 shows a typical camera module from a mobile phone.

A basic mobile phone camera module contains an image sensor and a plastic lens that captures the light from the object as a raw image. Nokia N8 smartphone thus far has been the best camera phone in the market with superior quality image capture capability comparable to a stand-alone camera device. It has a 12 megapixel image sensor, AF lens with mechanical shutter and neutral density filter. The AF lens optics contain combination of lens modules made up of glass and plastic with the precision branded by Carl Zeiss.

Due to rapid technological advances cheaper, smaller and more efficient digital camera modules are being produced. Figure 2.8 illustrates how small the camera modules have become.



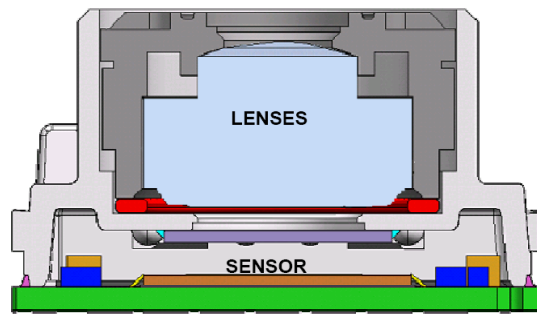

Figure 2.7: Typical mobile phone camera module [18]

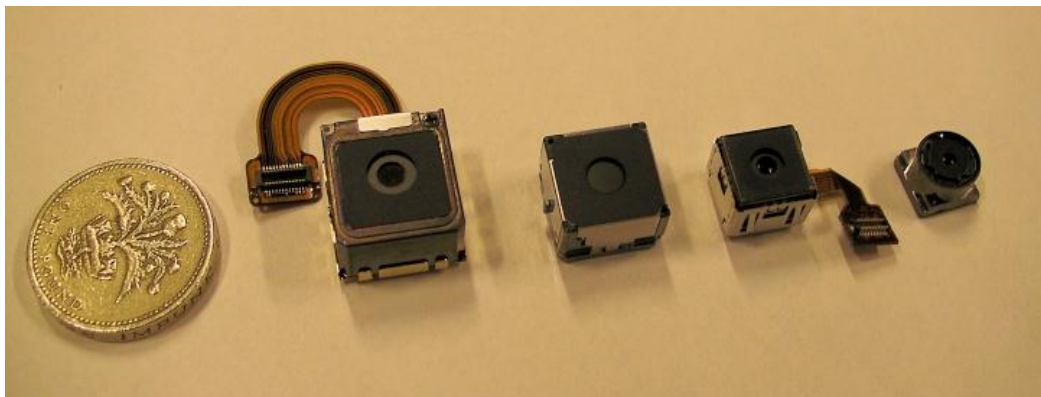

Figure 2.8: The camera modules of N73 (3.2MP AF), N86 (8MP AF), N97 (5MP AF) and C7 (8MP EDoF) alongside a UK One Pound coin [5]

### 2.3.2 Application Processor Engine

The application processor engine (APE) is the main processing unit of the mobile phone. A typical APE is shown in Figure 2.6 which is a microprocessor ASIC (Application Specific Integrated Circuit) chip. An APE in mobile phones most commonly contains an ARM (Advanced RISC Machines) core processor, a 32 bit reduced instruction set computer (RISC) for application processing and often an additional DSP (digital signal processor) which handles computationally heavy processes such as image, audio and video encoding.

In Symbian devices APE boots and runs the Symbian OS and executes user applications like contacts, messaging, calendar etcetera. APE is capable of handling multimedia processes such as audio, video, still image, graphics, media player and games. APE deals with phone's memory management and the file system and is capable of handling all the device peripherals like display, key input and camera.

### 2.3.3 Imaging and Video Engine

Imaging and Video Engine (IVE) is a dedicated processor for handling camera and flash system as depicted in Figure 2.5. IVEs are camera HW accelerators which are fully programmable application-specific processors that take care of all imaging and video related processing, for example, controlling the cameras and flash, creating the image files from camera raw data, encoding and decoding video. They are operating along with the phone's APE to take the high computational load associated with imaging and real-time video processing.

Over the years IVE has grown in functionality. Besides controlling only camera and flash specific functions, IVE has extended also to handling graphics and display. With the latest Symbian^3 Nokia phones based on IVE3 family accelerators, IVE is responsible for the graphics rendering and HDMI controlling. In addition to that it also introduces new capabilities on imaging area, including several image processing algorithms like face tracking, red eye removal and image stabilization.

### 2.3.4 Flash Module & Privacy Indicator

Flash module is an artificial light source that illuminates close range objects thereby providing sufficient lighting to capture images with the phone. Most of the Symbian phones support the torch feature where in the flash module on the device can be used as a torch by putting it on for a long duration. Privacy indicator is often a red LED beside the camera that emits red light when the video capture is on or when the image capture is done. This is to announce that the phone's camera is in use which according to the legal laws of some countries is mandatory.

Nokia Symbian OS phones are using 2 types of Flash Modules: LED and Xenon. A separate red light emitting privacy indicator is used in some of the phone models.

There are different implementations of these flash modules from different manufacturers with their own driver chips and ways of interfacing. The flash needs to be synchronized with still image capture for the best results. There are several efficient possibilities of using flash during viewfinder to aid final still image quality. If the privacy indicator is not present then some phones use flash in low power mode to indicate that a capture is in progress when flash is not required.

### 2.3.5 Flash Driver

Flash driver is an ASIC chip connected to flash modules that controls the flash functionalities. Flash driver has set of control registers through which the functionalities like the duration and the intensity of the flash can be set. Likewise, it has several data registers that store the life time counter information which reveals how many times the flash has been fired, the manufacturer's ID and version information. It also contains status registers that save information about faults that may occur with the flash usage.

## 2.4 SMIA (Standard Mobile Imaging Architecture)

Following are the demands created by ever growing mobile imaging devices:

- The rapidly increasing image sensor resolution necessitates the data interfaces to be capable of handling high data rates.
- The camera must be small in size and may be flex mounted. Therefore a low pin count is desirable.
- High volume mobile application favour second sourceable components with a standardized electrical and mechanical interfaces.
- Second sourcing requires that camera modules also have similar optical performance. A common way of measuring performance is needed to truly compare different products.
- Rapidly changing consumer markets for mobile products require a fast design and industrialization cycle. The use of standards speeds up both the component design cycle and the design-in process at the end user.

To address these demands Nokia together with ST Microelectronics has setup SMIA which is an imaging architecture standard especially suitable for mobile devices. The scope of SMIA covers a Raw Bayer output image sensor head. It specifies housing, mechanical interconnection, functionality, register set and electrical interface for camera modules. Control of camera sensor is done by reading from and writing to registers within the sensor, a pre-defined set of registers is specified so that any SMIA compatible sensor may be setup and controlled in a standard fashion. It also allows flexibility by allowing of Manufacturer Specific Registers (MSRs). Most of the Nokia Camera phones follow this standard [7]. SMIA++ is the new version of SMIA that includes a lot of detail that was not available during SMIA design such as Auto Focus (AF), Extended Depth of Field (EDoF) as well as handling larger pixel amount sensors better by introducing a standard to increase image bus speed capabilities.

## 3 SYMBIAN OS

Symbian OS is a software platform for smartphones; the purpose of the platform is to provide a foundation for smartphone software, including an integrated application suite and a number of software libraries, frameworks, and APIs. A common platform for smartphones has several advantages. Firstly, it enables rapid software development for new smartphone products and reduces time-to-market. Secondly, it improves software compatibility across devices from different manufacturers and enables native 3rd party application development. This chapter explains the main characteristics of Symbian operating system and the multimedia architecture within it.

### 3.1 Introduction to Symbian OS

Symbian Ltd was founded in 1998 lead by a consortium including Nokia, Ericsson, Motorola and Psion to develop and supply an open and standard mobile device platform, Symbian OS. Roots of Symbian OS go back to 1980's when Psion created a 16-bit operating system for small mobile devices with long operating times. In the middle of 1990's they discovered the limitations of 16-bit architecture and started rewriting the system. The new 32-bit operating system called EPOC was ready to be released in 1997. The first operating system release Symbian made was EPOC release 5 in June 1999. After that release the operating system was named as Symbian OS. Series 60 (S60) is Nokia's graphical user interface framework that runs on top of Symbian OS. The terms S60 and Symbian OS are quite often used interchangeably.

Nokia acquired Symbian and in 2009, Symbian Foundation was established to make the Symbian platform available open source and royalty-free. Further in November 2010 the foundation ramped down its operational activities as a result of changes in global economic and market conditions. Symbian<sup>2</sup> was the last Symbian OS release from the foundation for smartphone manufacturers outside Nokia. The foundation is transitioned from a non-profit organisation responsible for governing the open development and curation of the Symbian platform, to a licensing entity with no permanent staff. It is responsible only for specific licensing and legal frameworks put in place during the open sourcing of the platform. Nokia launched the current and the latest platform release Symbian<sup>3</sup> in 2010. Currently there is a huge consumer base of Nokia Symbian smartphones that is based on S60 3.2, S60 5.0 aka Symbian<sup>1</sup> and Symbian<sup>3</sup> platform releases in the market that Nokia together with Accenture are supporting.

## 3.2 The Scope of Symbian OS

The Symbian platform includes a customizable user interface, a rich set of applications, common user interface components and development tools for implementing new applications. It also includes tools and documentation that enables device manufacturers and application developers to create feature-rich devices and applications. The whole system, down to the lowest level of the operating system (kernel), is based on the object-oriented design and is implemented in C++. Only the lowest level hardware specific and most time critical functions are written in assembly language.

The processor's power and memory size are limited in small devices. This demands the operating system to be stingy with the system resources. Reliability is one of the key requirements of mobile and handheld devices. They must be as resilient as paper diaries and agendas. This is a very strict assumption, because any data loss in a personal mobile phone may cause a loss of trust for that product or even for the whole company. Symbian OS aims to achieve the robustness and stinginess in resources by using its own process handling mechanisms, an easy-to-use error handling framework that is also responsible for out-of-memory errors, an effective memory management that is handled by a memory management unit (MMU), and by encouraging the developers to object oriented SW development.

The devices in which Symbian OS runs operate in wireless environment, where the connectivity is usually episodic by nature and network coverage can change dramatically from one area to another. This is why Symbian OS has to support multiple protocols dependent on the available network. Symbian OS includes many layers of network operability and it supports many different network standards such as Bluetooth, infrared and wireless LAN. Symbian OS supports also a lot of other functionality that multimedia devices need.

Symbian's goal is to provide openness for third party SW developers. This means that it provides application-programming interfaces (API) to the resources so that third parties can develop software on the Symbian platform. These APIs are released for developers in software development kits (SDK).

## 3.3 Dynamically Loadable Components

Just like almost any modern operating system Symbian OS provides a way to load application components dynamically at run-time. In Symbian OS there are basically three different ways to do that: static interface DLLs, polymorphic interface DLLs and ECom components.

### 3.3.1 DLL Entry Points

DLLs in Symbian OS always have an entry point that is usually called when the library is loaded and unloaded. The entry point `E32Main()` has to be implemented by the developer but usually its implementation is left empty. It is possible, however, to put

some global initialisation or cleanup code into the entry point of DLL but it is not recommended.

### 3.3.2 Static Interface DLLs

Static interface DLLs in Symbian OS are exactly the same kind of dynamically loadable DLLs that exist in many other operating systems. They are called static interface DLLs because they export a static table of functions that can be used in other applications.

Static interface DLLs can be used by linking the application against import library (.lib file) that corresponds to the used DLL. Operating system then guarantees that correct libraries are loaded when an application is run.

Static interface DLLs are very efficient when there are multiple applications that need the same functionality. That functionality can be wrapped inside a static interface DLL and the operating system loads only one instance of the library into memory even though there are multiple applications using it. If the DLL is located on ROM it can be even executed directly from there without loading it to RAM at all. In addition to improving memory usage of applications, static interface DLLs also provide abstraction and modularization for project because a piece of logical design can be encapsulated inside a library.

### 3.3.3 Polymorphic Interface DLLs

Static interface DLLs expose multiple entry points to the outside world but polymorphic interface DLLs provide only one. The only exported function can be of any kind but usually it is a factory method that can be used to create an implementation object of a well-known interface with one or more pure virtual functions. Created object is often a factory that can be used to further create new objects. This way polymorphic DLLs can be used as a certain kind of an extension point for application. [2]

Polymorphic DLLs are identified using unique identifiers (UIDs). DLLs having a specific UID are known to implement a specific interface. That way applications are able to know if a DLL implements the needed interface.

Polymorphic DLLs are used quite extensively in Symbian OS. For example all application EXEs are polymorphic DLLs that the framework loads when the application is started. Also device drivers and many other operating system level components are polymorphic DLLs.

Normally the single exported function of a polymorphic DLL is called by the operating system only. This is the case in applications and polymorphic components of the operating system. However, it is possible to load the DLLs programmatically using loading facilities provided by the operating system.

### 3.3.4 Symbian ECom Architecture

In C++, the existence of abstract base classes and virtual functions allows the programs to call, or access interfaces without knowing the actual implementation.

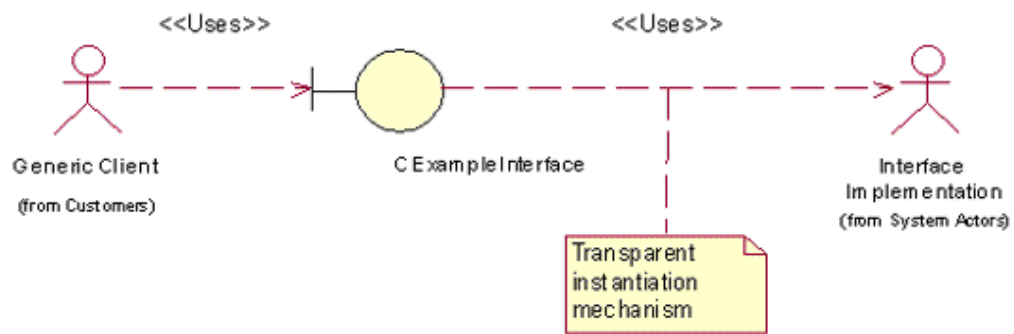

Figure 3.1: ECom relationships [2]

This mechanism gives a flexibility of writing the implementation independent of the interface. The implementations are known as Plug-ins. When an application wishes to use a plug-in, an object is to be instantiated to perform the required processing. The object specifics are not known until run-time. The general characteristics of the processing are known, and these are presented as an interface API.

In the early version of Symbian OS, applications that use polymorphic DLLs were responsible to search and load the DLLs explicitly themselves. The Symbian ECom architecture [2] introduces a generic framework that provides a single mechanism to

- register and discover interface implementations
- select an appropriate implementation to use
- plug-in version control.

Client applications can query the ECom framework for an implementation of certain interface. Framework then returns an instance of an object that fits best the conditions the client has specified. It is also possible to query for all available implementations of an interface. Figure 3.1 shows the relationships between a client and the ECom framework.

### 3.4 The Software Architecture of Symbian OS

The Software Architecture of Symbian OS is a system model shown in Figure 3.2 which represents the operating system as a series of logical layers with the Application Services and UI Framework layers at the top, the Kernel Services and Hardware Interface layer at the bottom, sandwiching a ‘middleware’ layer of extended OS Services. A layer provides services to higher layers and delegates tasks to lower layers [6].

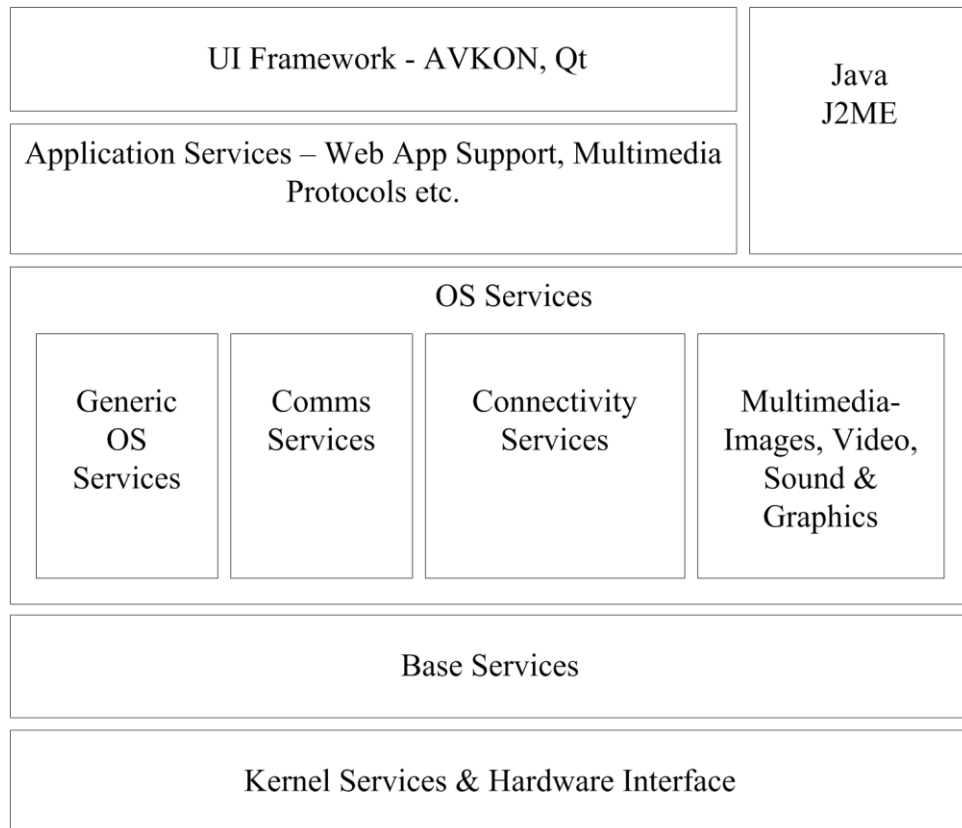

Figure 3.2: Symbian OS software architecture

In a finished product, i.e. a mobile phone, Symbian OS provides the software core on top of which a third-party-supplied ‘variant’ user interfaces (UI) as well as the custom applications supplied by the phone manufacturer provide the custom graphical user interface (GUI) through which end-users interact. Beneath the operating system, a relatively small amount of custom, device-specific code (consisting of device drivers and so on), insulates Symbian OS from the actual device hardware. Since Symbian Camera system utilizes components from each of these OS layers, those are introduced in the following chapters.

### 3.4.1 UI Framework

The UI Framework is the topmost layer of Symbian OS that provides frameworks and libraries for building customized user interface based applications. This enables the application developers and device manufacturers to differentiate their UI offerings to suit the touch UI or keypad based phones.

The user interface architecture in Symbian OS is based on a core framework called AVKON and a class hierarchy for user interface controls called the control environment. Cross platform framework Qt is supported as well. The typical user interface controls consist of window border, soft-keys, editors, scrolls and such. The UI framework also includes a number of special graphics based frameworks which are used



by the user interface but which are also available to applications including the Animation framework, the Front End Processor (FEP) base framework and Grid.

### **3.4.2 Application Services**

The Application Services layer provides user interface independent support for applications on Symbian OS. Services from this layer are used by all applications but mediated by the UI Framework layer, for example, application installation and launching, view switching, and the basic application architecture relationships. The Java ME layer also uses the frameworks and services from Application Services layer.

Services provided by this layer range from those used by all applications like basic application frameworks, text handling and secure software install to those providing technology specific logic like for example support for device management, messaging and multimedia protocols, to services targeting specific individual applications namely Camera Application Engine and office applications support.

### **3.4.3 Java ME**

Java Micro Edition (J2ME) layer spans the UI Framework and Application Services layers, abstracting as well as implementing elements of both for Java applications. This layer encapsulates Symbian OS for Java J2ME applications (MIDlets), and includes a Java virtual machine, the Mobile Information Device Profile, and packages that provide functionality such as communications and multimedia support.

### **3.4.4 OS Services**

In terms of the number of components, OS Services is the largest single layer of the Symbian OS. OS Services layer is the middleware layer of the Symbian OS that provides the servers, frameworks and libraries that implement the core operating system support for graphics, communications, connectivity, and multimedia, as well as some generic system frameworks and libraries (Certificate and Key Management, the C Standard Library) and other system-level utilities (logging services). In effect, it is the layer that extends the minimal base layers of the system (the kernel and the low-level system libraries that implement the basic OS primitives and idioms) into an extensible, programmable, and useful operating system.

The Multimedia and Graphics is one of the functional blocks from OS Services that provides support for graphics and audio, from simple drawing primitives to playing and recording multimedia formats. This block includes Multimedia Framework and Onboard Camera API which are the key components in Camera Software architecture.

### **3.4.5 Base Services**

Base Services layer extends the bare kernel into a basic software platform that provides the foundation for the remaining operating system services, and effectively encapsulates the user side of the ‘base’ operating system.

In particular, the Base Services layer includes the File Server and the User Library. The Base Services layer also includes the components needed to create a fully functioning base port without requiring any further high-level services with the Text Window Server and the Text Shell. Other important system frameworks provided by this layer include the ECom Plug-in Framework, which implements the standard management interface used by all Symbian OS framework plug-ins, the Store which provides the persistence model, the Central Repository, the DBMS framework and Cryptography Library and Camera Adaptation.

### **3.4.6 Kernel Services & Hardware Interface**

Kernel Services & Hardware Interface layer performs the fundamental operating system tasks of interacting with hardware, managing access to device resources and booting the device thereby insulating all higher layers from the hardware.

A multi-tasking, real-time operating system kernel is the main component in this layer that manages the fundamental OS tasks, threads, processes, memory management, and scheduling. Access to the kernel by user-side programs (program that are not run as part of the kernel) is through the user library from the Base Services layer. The kernel contains both generic code, and code that must be customized to work on particular hardware platforms.

This layer provides the physical and logical device drivers that abstract device hardware into logical devices. Camera PDD and camera LDD are part of this layer.

## **3.5 Camera and Video System Architecture**

The generic software components within the camera and video system architecture in Symbian OS are shown in Figure 3.3 and the following sections introduce the components relevant to camera system.

### **3.5.1 Camera Driver**

Camera driver provides low level interface for controlling camera modules, flash modules and camera HW accelerators. As HW accelerators grow in functionality, they have been extended to support video playback and image decoding as well.

The Camera driver follows the Symbian two tier driver architecture with Camera Logical Device Driver (CamLDD) and Camera Physical Device Driver (CamPDD).

CamLDD provides an abstracted interface to the camera hardware and supports the functionality common to a product variant.

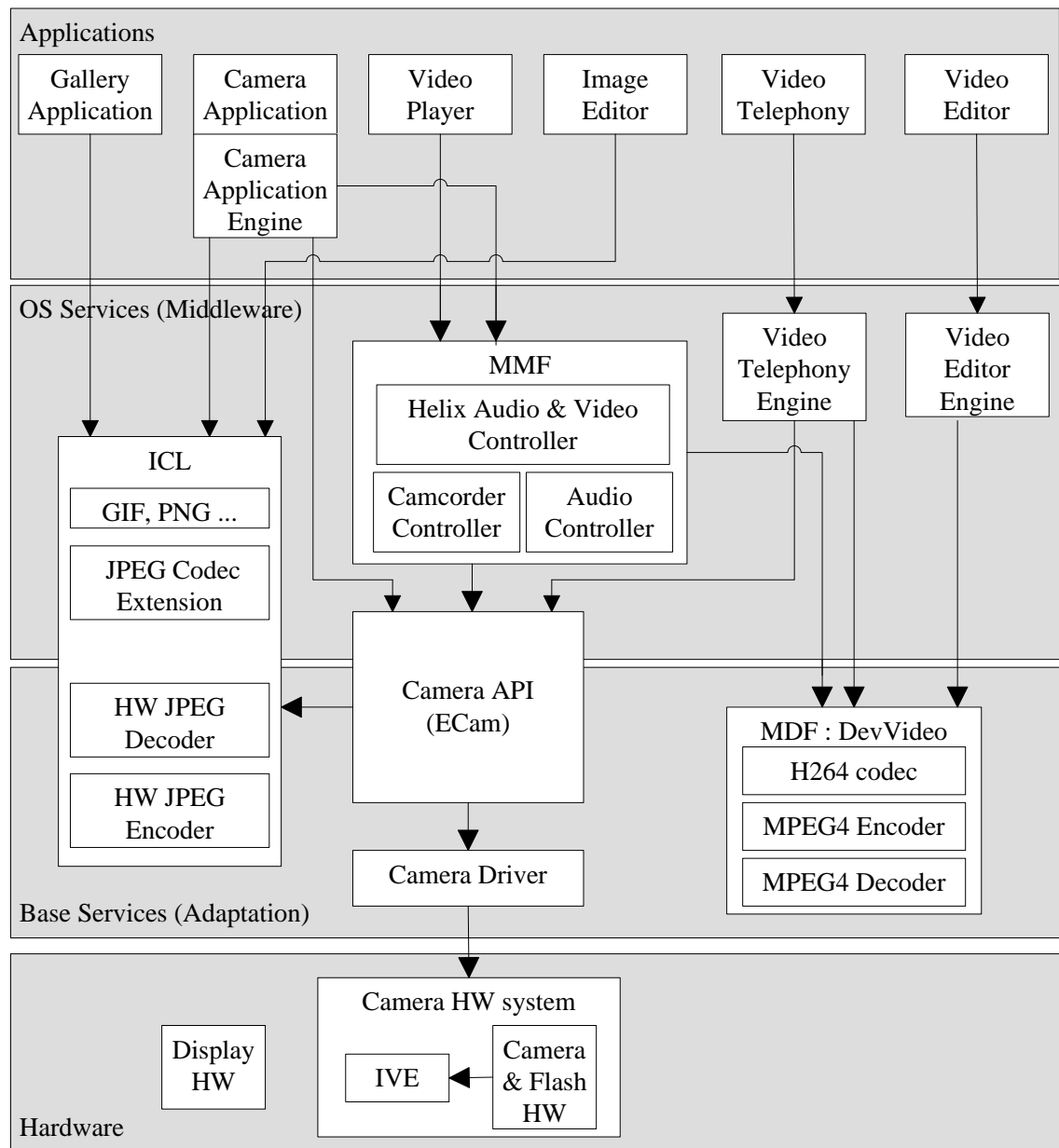

Figure 3.3: Overview of camera and video system architecture

CamPDD is Camera specific device driver that provides low level interface to the camera HW. An 8 megapixel camera could have its own driver that supports various modes and capture requests and a specific LED driver that initiates flash related requests on LED flash HW. Generally this part contains most of the driver functionality that handles the communication with the Camera & Flash HW.

### 3.5.2 Multimedia Framework

The Multimedia Framework (MMF) provides a lightweight, multi-threaded plug-in framework for handling multimedia data. MMF enables audio and video recording, playback and streaming as well as image related functionalities through its framework

of controller plug-ins. The MMF controller plug-in provides support for one or more multimedia formats, for example MP3 or AVI. In addition to controller plug-ins, the MMF can also be extended through format encoder, decoder, codec and sink plug-ins.

The player and recorder interfaces of both audio and video as well as the audio converter interface use the controller plug-ins provided by the MMF. These plug-ins provide the functionality to convert, to interpret and to play audio and video data. The resultant data from the plug-ins can then be directed to one or more sink such as a file, or directly to the display screen or lower level device driver

MMF also provides enablers for a tone player interface that enables playing tones such as DTMF (Dual-Tone Multi-Frequency) and an audio streaming interface that enables recording and playing audio streams such as audio from a web address. The tone player and the audio streaming interfaces do not require controller plug-in for encoding or decoding since the input and output data formats with these are already known. As a result they bypass MMF controller framework [2].

### **3.5.3 Image Conversion Library**

Image conversion library (ICL) is a lightweight still image framework that supports many features like encoding, decoding, scaling, rotating, producing mirror image, flipping and cropping images [2]. It supports these features through variety of APIs that applications and ECom can make use of. ICL supports various formats, like JPEG, GIF, BMP, MBM, TIFF and ICO. ICL is extensible in nature since it is developed as a Symbian ECom framework. Third party plug-ins can be added to the Symbian camera system that extends and supports more image conversion options via ICL.

### **3.5.4 Onboard Camera API**

Symbian Onboard Camera API, also known as ECom driver, provides an extensible set of APIs that allows applications to utilize the camera and the flash hardware on Symbian devices. ECom provides access to basic camera related functions such as using real-time viewfinder, capturing still images and giving frame data information for video encoding. The APIs allow application software to enumerate available camera devices and query for supported image formats and features. White balance, flash mode, and several other image capture parameters may be adjusted using the API. A client using the API needs to reserve the camera hardware for exclusive use. Having multiple clients using the same physical camera is not allowed, but there may be several physical cameras on the device. The clients for ECom are the UI applications and the Multimedia framework.

The basic version of Symbian ECom provides stub interface, i.e. custom interface mechanism which allows extensions to be added into the API without breaking compatibility with older clients. In practice this means that the ECom APIs, which are actually virtual functions defining basic common operations, can be extended by incorporating proprietary properties as actual function implementations.

### 3.5.5 Camera APP Engine

Camera Application Engine provides the functionality of view finding, still image capturing, video recording, and the related settings to the Camera Application. Apart from fetching the information from the Onboard Camera API (ECam) it also requests methods to handle bitmap images from Symbian's Font & Bitmap Server API. The basic engine can be extended using Custom Interfaces and plug-in extension modules.

### 3.5.6 Camera Application

Every Symbian camera phone has a built-in camera application that provides a user interface to access the phone's cameras. The camera application gives the option for still image capture and video recording. Camera is a stand-alone Symbian application, which can also be launched embedded, for example from messaging application or a third party social networking client like Facebook. Embedded camera application is an independent process which runs in its own process space. Such multiple embedded instances of the camera application can exist simultaneously running on the phone, but only one instance can use the camera HW at a time. Figure 3.4 is a Settings view from the Camera application. Switching between image and video mode, or main and second camera, selecting possible resolutions, white balance, flash settings can be achieved from the application's user interface.

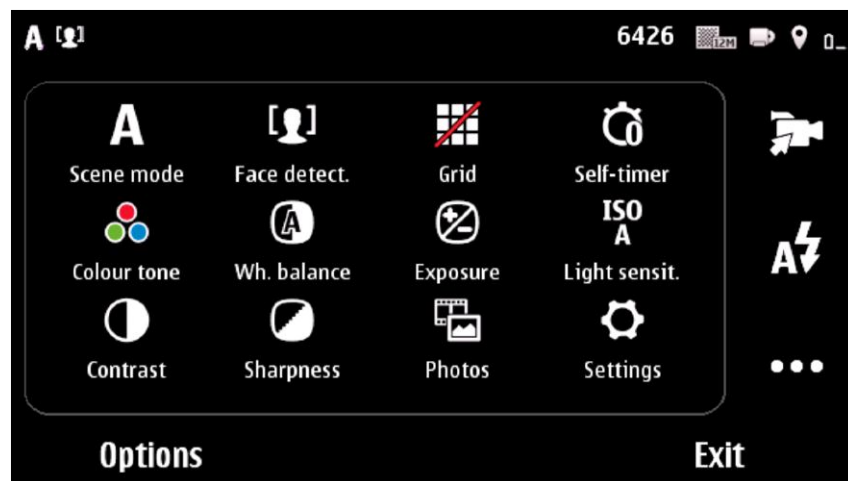

Figure 3.4: Camera application from Nokia N8

## 4 SOFTWARE VARIATION

A mobile phone platform should be capable of supporting mobile devices with varying hardware configurations and different software based feature variants. This would enable the mobile phone manufacturers to differentiate their offerings in order to cater to different markets. Supporting such varying and vast configurations with one OS platform release could be possible by using software variation mechanism.

This chapter introduces the reader to the topic of software variation. First production line engineering is discussed to show why flexible software variation is important in the context of platform development. Then different software variation techniques are presented and their advantages and disadvantages are considered.

### 4.1 Production Line Engineering

Production Line is a set of related applications. Each application can be specialized in some way to create products for different environments and devices. Developing new features for applications may require writing new components to production line and then combining those components to produce actual applications [9].

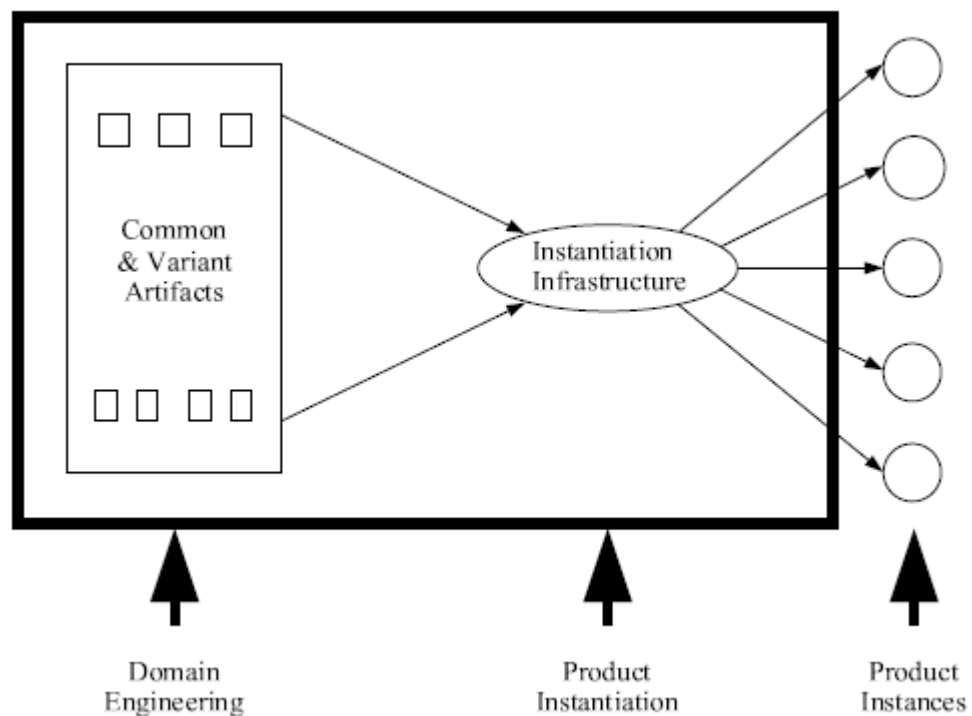

Figure 4.1: Production line structure [10]

Production line can be thought of as a pool of reusable components that can be then combined to form actual products using a specific instantiation infrastructure. However, production line does not contain the individual products that are instantiated. Figure 4.1 shows the structure of production line. The idea behind production line engineering is that “individual products should be treated as transient outputs of the production line that can be discarded and re-instantiated as needed” [10].

Good software variation techniques are important to enable efficient product instantiation infrastructure. Software has to be designed for variation from the beginning to make it possible to instantiate different versions of the software with selected feature sets. There are several variation techniques that can be used to accomplish needed variation level for production line engineering. Chosen variation techniques affect the instantiation infrastructure and therefore the whole production line.

## 4.2 Software Variation in Production Line Engineering

Software variation in conventional software development is about managing the evolution of software over time. Management of variation over time is also known as configuration management or version management. Sequential and parallel time variations are both supported by many configuration management tools and there are well known management methods for them. For normal software development managing only variation over time is normally enough because software is usually developed for a known hardware configuration and platform. However, in software production line engineering something else is needed to manage the multitude of different devices [11].

Software variation in production line engineering is multi-dimensional. In addition to managing variation over time, also variation management in space is needed. Variation in space is about managing the different features of one product at any fixed point in time. This is closely related to production line engineering because it also addresses the problem of instantiating concrete products with specific feature sets from varied components [10].

Designing for variation differs significantly depending on which kind of variation we are designing for. Designing for variation over time means anticipating future requirement changes and new requirements so that the existing system structure may easily adapt to changes. Separating components clearly and building a sound architecture is necessary to enable flexibility in software and therefore help variation over time. That kind of design is relatively well understood and many design patterns have been developed to support it [13].

Designing for variation in space on the other hand is completely different because it has to be possible to instantiate the same product with multiple different feature sets at any time. Variation in space is the variation type that is needed to enable production line engineering. Of course also variation in time is important for efficient software development processes that are used also in production line engineering. However, without good methods for variation in space the whole instantiation infrastructure would be ex-

tremely hard to build and therefore the production line would not be complete. Also, the instantiation infrastructure would be very hard to configure and therefore it would be hard to build same application with different feature sets.

### 4.3 Variation Point

Variation point is some point in an application in which the execution of the application may take different paths depending on what features are enabled or disabled. Variation points may be specific to one application, span multiple applications or even the whole platform. For example enabling Bluetooth feature may add menu items in several applications but enabling MMS messages possibly affects only on messaging application. Even though there are variation points that may span the whole platform each application still has to take care that it behaves correctly with each of the possible feature combinations.

#### 4.3.1 Types of Variation Points

When implementing variation points and choosing an appropriate variation method it is essential to know what kind of variation is being implemented. In general there are three types of features that may be varied. In addition to these three types there is naturally one more type which is a feature that is always included in an application.

The first type of a feature is an optional feature. An optional feature may be enabled or disabled in an application. This is the simplest type of variable features and also the easiest to implement. This kind of feature is for example a search feature in a file management application: searching of files from the file system is either enabled or disabled.

The second type is an alternative feature. An alternative feature is chosen from a set of features from which only one feature may be enabled at a time. All others are disabled. An example of an alternative feature is selecting a language variant: even though a mobile phone may contain support for multiple languages only one of them may be enabled at a time.

The third and last type of a feature is a generalization of the alternative feature type. This is so called multi-feature where there can be multiple features enabled from a set of features. The different variants of the feature are not therefore mutually exclusive. Example for this kind of feature is a file sending feature in a file management application: it is possible to send files over infrared, Bluetooth, or MMS. Each of those features may be enabled or disabled independently of each other.

In the source code variation points may be implemented using several techniques. Variation point may be a conditional statement where one branch of execution is taken if a feature is enabled and the other is taken if the feature is disabled. A variation point that most closely resembles the object oriented thinking is a virtual function call. Virtual function call replaces conditional with polymorphism [14]. In that case the variation is



decided by creating a different implementation for an abstract interface depending on whether a feature is enabled or not.

In addition to previously mentioned variation type, also variation binding time distinguishes variation points from each other. Variation binding time may be compile-time, link-time, ROM image creation time or run-time. Of these four the compile-time and link-time variation can be discussed together as static binding times and run-time variation uses dynamic binding time.

ROM image creation uses actually static binding time but depending on the situation it can also be understood as dynamic variation, because sometimes DLLs that are put to the ROM image are loaded by applications as extension components during run-time. So the configuration is decided statically when ROM image is built but the software adapts dynamically to that configuration at run-time [8].

### 4.3.2 Variation Points in Symbian Platform SW

The Symbian software needs to be varied because of the following reasons:

- There are different Symbian variants depending on product, target market area, operator, and so on. For example, features such as Camera, infra-red, Bluetooth, and cellular protocols may need to be varied; i.e. added, dropped, or modified.
- Symbian licensees need to have different features.
- Products may have features used only for R&D; for example, for test and debugging purposes.
- Future releases of Symbian will introduce new features, which cannot be integrated into the previous versions that are in the maintenance mode.

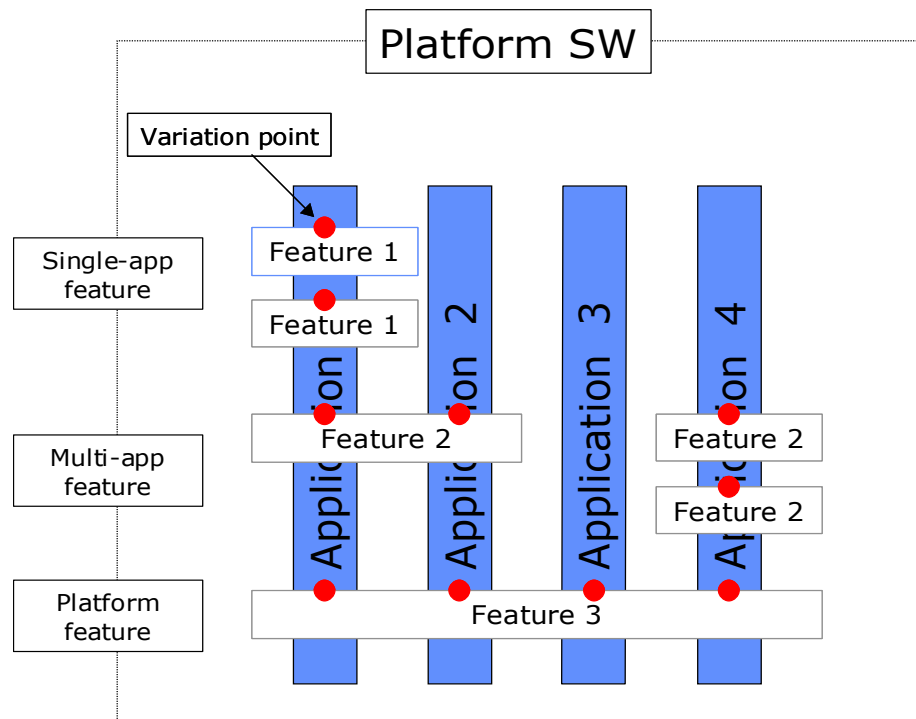

Figure 4.2: Variation points in Symbian platform SW

Variation is controlled at various locations in the Symbian software build. These variation points determine how features are included or excluded in the build. A feature may have an effect on only a single application, on multiple applications or on all applications in the Symbian OS platform SW on which a set of products run. Again, a feature change may affect only a single application, many applications or all applications in the platform. Figure 4.2 illustrates and variation points across the Symbian platform SW. Application here means any component from the software stack, device driver, application engines or a GUI application.

## **4.4 Software Variation Methods in Symbian OS**

This section provides an overview of the Symbian build system and introduces different variation mechanisms available in Symbian OS. Depending on the intended variation type and binding time, different variation mechanisms can be chosen. Some of the variation mechanisms support multiple variation types or even all of them. However, the most important issue when selecting a variation type is to keep the design of an application clear and code maintainable.

### **4.4.1 Software Build System for Symbian OS**

Symbian platform release supports several device families. A device family consists of products belonging to the same HW platform, which is mainly decided by the used APE ASIC and possibly by other key ASICs like IVE. A device family typically consists of tens of products and their variants. If including all the operator and market specific variants with different language and localized content options, the number of different variants gets easily to several hundreds.

The build environment for Nokia Symbian phones usually covers one or several device families. To be able to handle the whole build system with reasonable effort, efficient variation mechanisms are required. For example to keep the amount of files in control, roughly half a million files currently, files must not be duplicated for each product but instead the different requirements must be supported in the same files through configuration options as far as possible. In order to keep the compiling and building times feasible, it must be possible to build common parts of the system only once and reuse the build products throughout the product range. All this especially as the same build system is used both in dedicated build servers and in individual developers' local computers.

Figure 4.3 depicts a typical build system used with Symbian OS in order to build the platform release and create product ROM images. The release includes product specific feature variant header files that contain the product specific feature flag definitions and are visible across the whole Symbian platform code-line.

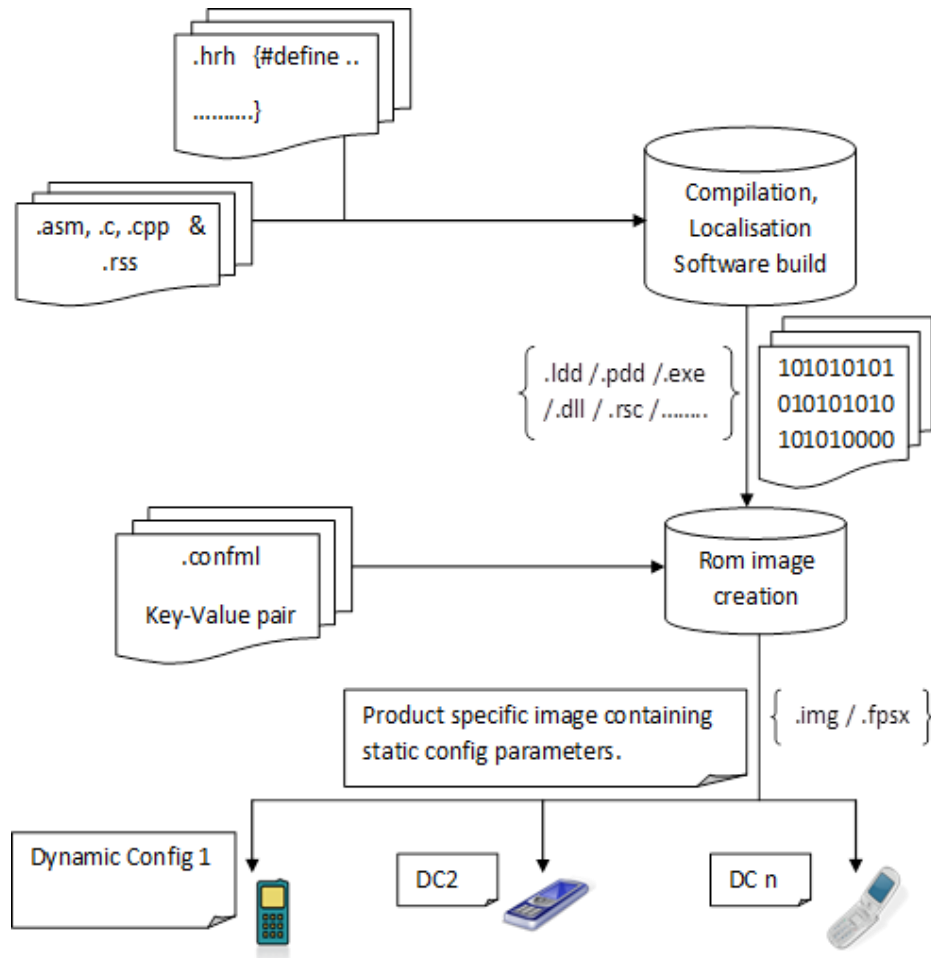

Figure 4.3: Software build system for Symbian OS

For example the feature variant header file for product A, productA\_settings.hrh that includes product specific definition:

```

#undef INFRARED_ENABLED //Infra-red not supported
#define CAMERA1_TYPE 12mpix_Cam //Primary camera is 12megapixel
#define SEC_CAM //Secondary camera supported
  
```

These flags could be either static or run-time feature flags. Usually flags are given either boolean or integer values. Run-time flags are assigned a 32 bit unique identifiers and during the build process they are fetched into a product specific .dat file along with their values. For example, the feature data file for N8 under the Symbian release would be “\epoc32\ release\data\N8\features.dat” file that gets into the N8’s ROM image. Feature discovery APIs are used by the Symbian OS components for querying whether a particular feature is supported or not, during run-time.

Central repository key value pairs from the Symbian .confml files are fetched into certain binary repository files with file extension .cre during the ROM image creation time. These .cre files reside in the product ROM image. The central repository APIs are used during the run-time by Symbian OS components to query the value that a key holds.

On building Symbian platform, the build system compiles individual component source code, i.e. different applications, API libraries and device drivers across the Symbian platform layers. This produces binary files intended to be part of the product's ROM image under the EPOC32 folder structure of the Symbian release on build computers. The binary files are a set of executable with extension exe, libraries with extensions dll, pdd and ldd and resource files with extension rsc. The created binaries are of two types, common to all product variants or specific to only certain product variants.

The camera application binary “\epoc32\release\CameraApp.exe”, typically common for all the products, uses central repository and run-time feature flag discovery variation methods. The onboard camera API plug-in and the camera driver LDD files are generally product specific, both using static feature flag definitions for variation. For example for N8 they would be “\epoc32\release\N8\ecamplugin.dll” and “\epoc32\release\N8\camdriver\_IVE3.ldr”. Thus, the system builds a different ROM image for each product variant that it supports.

Apart from these variation techniques during different stages of build process, the dynamic configuration (DC) files can also be used in the post image creation phase. These DC files can be loaded into the product file system separately from the ROM image. These files contain certain tuning values for camera, display or any other product specific peripheral, thus enhancing the overall product quality. The values from these DC files override the original values that are in the ROM image.

#### 4.4.2 Feature Flag Settings

The software functionality can be varied by flagging some of its code so that the flagged parts of the code are only compiled if a feature flag has a certain value. The feature flags are generally defined or undefined in a high level product specific header file, namely feature\_settings.hrh, which is visible to the whole Symbian code line. The software functionality in the code is therefore selected at compile-time and can not be changed unless the code is recompiled. Programme 4.1 shows how the feature flag variation is normally implemented.

```
void CVariedClass::Function()
{
    // Common code for all variants
    #ifdef __FEATURE_A_ENABLED__
        // Implementation with feature A enabled
    #else
        // Standard implementation
    #endif // __FEATURE_A_ENABLED__
    // Common code for all variants
}
```

Programme 4.1: Compile-time variation

Feature flags are often used in IBY and OBY, the ROM image component include files. For example in cameradriver.iby file that includes specific camera driver

component to the ROM image, the required driver can be chosen into the image depending on the feature flag definition as follows:

```
#ifndef CAM_HWA // if camera HW accelerator feature is supported
// Include HW accelerator version of the camera driver
\epoc32\release\armv5\camHWdrv.dll \library\camdrv.dll
#else
//Include the generic camera driver to the image.
\epoc32\release\armv5\camdrv.dll \library\camdrv.dll
#endif
```

Using feature flags can be problematic for version controlling and testability of the software. If there are several feature flags then all the possible combination of the flags should be tested. Increasing the number of flags increases the time needed for testing exponentially. Also when making changes, for example fixing bugs in the software, each part enclosed within a feature flag has to be carefully considered to make sure that the change is included in all possible feature flag combinations.

#### 4.4.3 Feature Discovery API

Symbian software provides Feature Discovery APIs to fetch the feature flag values. These values are then used to determine programmatically which optional features are present on the device executing the application. For example using the secondary camera with the video call is possible only if the secondary camera feature is supported on the device. Programme 4.2 illustrates the variation mechanism using the feature discovery API. SEC\_CAM is a run-time feature flag with a unique identifier within the Symbian OS and is defined for a particular product if it supports secondary camera feature.

```
void CVideoCall::CameraHandle()
{
    // Common code for all variants
    if( featureManager.IsSupported(SEC_CAM) )
    {
        // Implementation to get handle to sec cam
    }
    else
    {
        // Standard implementation; get handle to primary camera
    }
    // Common code for all variants
}
```

Programme 4.2: Run-time variation

However, this is not dynamic variation as such since the flag values can only be changed in the ROM image creation phase. Using this mechanism brings the same challenges to testing as feature flags.

#### 4.4.4 Central Repository

Symbian OS's Central Repository (CenRep) can be used to store the functionality flags and the value of the flags can be changed dynamically. This does not require rebuilding of the code. Central repository is basically a key – value pair system and one of the biggest limitations of this system is that the keys have to be pre-defined. Also central repository can not be used for storing large amounts of data like for example bitmaps.

Conceptually the Central Repository (CenRep) is comparable to a folder, an individual repository to a file and a setting to a line in a file. In fact, repositories are implemented as binary files held at various locations in memory and are accessed through C++ classes which encapsulate them with a single API. Repositories are created with the applications to which they refer at device build time or at installation by the Application Installer on runtime. The Central Repository APIs are available for applications to access repositories, fetch and update the values of a particular flag.

Consider a case where the camera shutter sound which has to be played on image capture should never be muted but kept at minimum volume level. CamShutterSound is one among many keys defined in the central repository definition file for the camera application. This CenRep Key represents the camera shutter sound which can have values 0 or 1. In the camera application's CenRep definition file cameraApp.confml,

```
<feature ref="CameraAppSettings" name="Camera Application Settings">
  <setting ref="CamShutterSound" name="Force Shutter Sound Always"
type="selection">
  <desc> If enabled, the shutter and video start/stop sounds are
played in all profiles.If disabled, camera sounds are disabled in si-
lent profile.</desc>
  <option name="Disabled" value="0"/>
  <option name="Enabled" value="1"/>
</setting>
</feature>
```

Considering a product for which this key is set as “Enabled”

```
<CameraAppSettings>
  <CamShutterSound>1</CamShutterSound>
</CameraAppSettings>
```

The binary file productA.cre that gets into the product ROM image would include this setting. The camera application that runs on scores of different Symbian OS products can query the value using the relevant CenRep API as follows:

```
TInt value;
// Create CenRep client object
CRepository* repository = CRepository::NewLC(CameraAppSettings);
// and fetch the value of a key.
repository->Get(CamShutterSound, value);
if(!value) //silent profile
{
  // Implementation not to mute but have the volume
  // set to a minimum level.
}
```

#### **4.4.5 Dynamic Configuration Files**

Though a particular mobile device is made with a certain type of camera module, there may be deviation in the quality of image it produces. The same type of camera modules may be using different versions of image sensors from different manufacturers or there could be slight variation within the optics causing the image quality (IQ) tuning values to deviate. A set of dynamic configuration files that contain the IQ tuning values for different cameras could be placed in a separate secure flashable image that is burnt on to the mobile phones having a certain type of camera modules. These files can be loaded to the phone during manufacturing process or afterwards by the end user as software updates.

## **5 VARIATION IN CAMERA SYSTEM**

The competition in the multimedia area has motivated mobile phone manufacturers to use multiple multimedia platforms and solutions. Camera system is an integral part of multimedia that should provide a seamless user experience across the variety of devices across mobile phone portfolio. This requires different camera and flash hardware configurations and software variation in the camera system. This chapter explains how this is being achieved in the Symbian platform for Nokia phones.

### **5.1 Purpose for Variation**

The products range from multimedia imaging centric high end mobile devices to entry level smart phones with basic level of imaging requirements. Irrespective of the phone category, its camera solution is subject to the same rapid development in the imaging technology within mobile phone arena.

The camera optical system is improving all the time with more precise lens system that is capable of collecting and focusing increasing amount of light from the object. The autofocus mechanism is getting better with less power and space consuming stepper motor that sits in the camera module. Apart from the increasing number of pixels on the image sensor of the camera, the individual pixel size is getting smaller. The control circuit on individual pixel which converts the light data in digital form is getting smaller, thereby leaving more area for the light sensitive part of the pixel. This has resulted in most efficient image sensor that can collect good amount of light to produce sharper images. All these have resulted in the smaller physical size of the camera module at lower price point. Similarly the flash system is getting better as well. The Xenon flash capacitors are getting smaller in size, which has so far been the limiting factor for utilising Xenon flash technology more widely. Flash modules with multiple LEDs are advancing by producing more natural colours and more intensive light while requiring less power than before.

The speed with which the camera technology is advancing necessitates Nokia to renew its camera portfolio in fast cycle. Nokia need to have efficient variation mechanism that supports the constant update in the camera and flash hardware configurations and in the Symbian camera software.

### **5.2 Camera and Flash Hardware Configurations**

Nokia Camera phones are based on different types of hardware configurations to control the camera system and to handle the image and video functionalities. In the camera



system several combinations of primary and secondary cameras with flash modules are possible. A single processor or IVE based multiple processor solution controls the camera system. Apart from these, during the development phase of the product cycle, several incremental early research and development (RnD) versions of the IVE chip, camera and flash modules are used until each of them are maturized. Following sections describe various camera hardware configurations in the Nokia camera phones.

### 5.2.1 Single Processor Configuration

Single processor system is the basic hardware configuration where the APE controls the camera system as shown in Figure 5.1. An APE generally includes its own DSP unit which is capable of aiding in calculation intensive image processing tasks. From HW complexity point of view this is simple to implement, only utilizing the generic processing power of the ASIC without requiring any imaging specific parts. This solution offers significant cost and size reduction to the products. As the camera software runs only on the APE ASIC, this configuration offers good possibility to port the same software components for an APE ASIC from another vendor thus providing high reusability for software components. However this setup typically do not reach the highest performance requirements and also consumes lots of resources, thus limiting other applications and processes running on the processor at the same time.

This single processor configuration is useful to cater cheaper phones with lower resolution camera sensors that do not require heavy SW codecs or algorithms in image processing. However this solution is not efficient enough to be used with high resolution cameras.

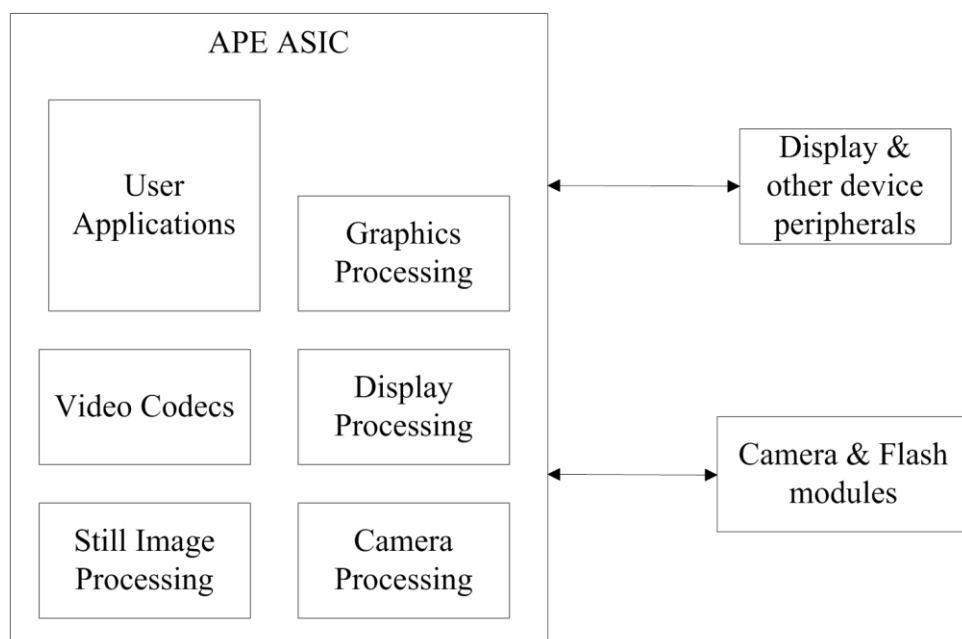

Figure 5.1 APE for camera system

### 5.2.2 Multi Processor Configuration

In multi processor configuration the phone includes an additional processor unit along with APE for handling camera HW acceleration. Nokia Symbian phones are using Imaging and Video Engines (IVE), which are full grown ASICs with their own CPUs, memory, HW ISP pipe and operating system SW. APE is responsible for loading the software to IVE in order to boot it up and for initiating the imaging operations according to user commands, but otherwise IVE is handling most of the tasks independently. IVE delivers the end results like viewfinder frames, still images and encoded video frames back to APE for showing on the display or for storing on the file system. IVE is typically controlling all imaging specific peripherals including both the primary and the secondary camera and the flash driver HW, like shown in Figure 5.2.

Having all camera and flash processing responsibilities on IVE enables the highest performance for the camera system without compromising the performance of the rest of the phone. On the other hand the APE does not have to be designed to manage the highest resource peaks required by the image processing, but its performance can be designed according to requirements of the rest of the system. Using moderately efficient solutions on both APE and IVE sides will result in one very high performing combined system.

Separate IVE ASIC allows faster development cycles in the imaging side since the imaging functionality is not strictly tied to the full phone ASIC development. It also enables to have more choice between different vendors on imaging area as competitive IVE solutions are offered by several companies.

Nokia's Symbian^3 phones are based on this configuration where IVE handles most of the heavy image processing functionalities and the graphics related processing as well.

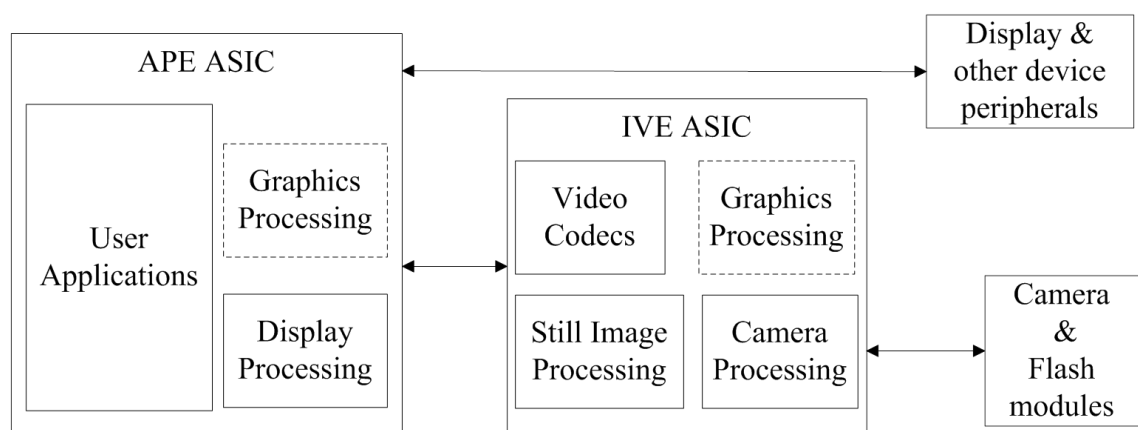

Figure 5.2: APE + IVE for camera system

### 5.2.3 System on Chip Configuration

Processor technology is advancing with multi-core processor solutions for mobile devices. A multi-core processor is a single electronic chip with two or more independent processors handling computing tasks in parallel, thereby increasing the efficiency of the overall system. System on chip (SoC) used for mobile phones integrate the multi-core processor along with several components of the device including different memory blocks, modems, timers, USB, analog to digital converters (ADC), digital to analog converters (DAC) and power management circuits.

SoC configuration enables IVE functionalities to be part of the same multi-core processor by integrating some of the ISP HW blocks as depicted in figure 5.3. This configuration is a compromising solution between single and multiple processor configurations providing efficient performance for the camera system without hindering overall phone performance. Integrating and productizing SoC for mobile phones brings cost benefits if compared to separate IVE chip solution, as it removes one major HW component from the system. However, with SoC the camera system development cycle is longer due to its dependency on full phone ASIC development. Also the performance of the APE needs to be designed to handle the peak load caused by the imaging tasks in addition to other operations.

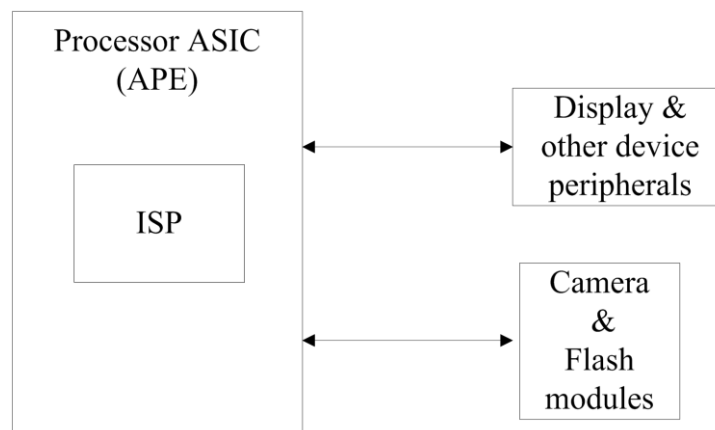

Figure 5.3: SoC for camera system

### 5.2.4 Types of Camera and Flash Modules

Nokia camera phones are built with different types of camera and flash modules as illustrated in Table 2.1. A low end, cost efficient device may include only one camera, i.e. the primary camera. An advanced multimedia capable phone usually has a primary camera, secondary camera and flash module. Each of these can have specific features that require variation in the way that they are handled.

The primary camera is usually the most complex component. It can have either a fixed focus lens, autofocus lens or EDoF lens. Autofocus lens may have different mechanisms for actually moving the lens, also it can include a separate position sensor for

more accurate lens positioning. Mechanical shutter and ND filter are options for high end cameras. Image sensor resolutions vary from few to tens of megapixels. Camera modules may contain non-volatile memory for storing tuning values that are used for enhancing the images. The secondary camera is simpler, usually varying only in image sensor resolution. The flash system typically includes a flash driver, which is a separate HW component capable of controlling the flash module. The type of the flash driver changes according to the flash module that it is controlling, there are different flash drivers for LED or Xenon based flash solutions. The capabilities of the flash drivers are also varying, from merely switching the LEDs on or off to gracefully controlling low battery charge or system power consumption peak situations. Depending on the LED type used, the system needs to drive a different amount of current through the LEDs in order to achieve the same level of illumination. In Xenon based systems, the charging of the capacitors is handled either by the flash driver or by IVE. Additionally one product line may include same kind of camera or flash module but from different vendors.

### 5.3 Variation with Camera Application

Apart from the default Camera Application there can be several applications on a Symbian device that need access to the camera. Camera application provides the graphical user interface to capture still images, video recording and videophone (video teleconferencing). Both the primary and secondary camera can be used with these use cases. A 3<sup>rd</sup> party developed social networking application such as Facebook may access the camera in order to take a picture for the purpose of uploading it to an internet server for sharing.

Typically, a mobile phone application is intended to be hardware independent so that the application can run on scores of devices running on Symbian platform. This way the application does not have to be re-written or ported for a device. In order to achieve interoperability the applications that interact with camera make use of run-time feature queries to check whether a particular camera functionality is supported or not. For example, on run-time camera application can query the number of cameras present on the device using ECam API and based on the result it can provide the UI options for the end users to choose the camera.

Programme 5.1 is camera application's implementation for switching camera object from primary to secondary camera. It makes use of ECam's CamerasAvailable method that returns the number of cameras present on the device.

```

void CCamAppController::SwitchCameraL( TInt aCameraIndex )
{
    // index 0: Primary camera, index 1: Secondary camera.
    // CCamera is a base class from ECam library.
    if( aCameraIndex < 0 ||
        aCameraIndex >= CCamera::CamerasAvailable() )
    {
        User::Leave( KErrNotSupported );
    }
    else
    {
        // First free old camera resources
        if( iCamera )
        {
            ReleaseCurrentCamera();
        }
        // Then create a new camera object
        iCamera = NewCameraL( aCameraIndex );
    }
}

```

Programme 5.1: Checking the number of cameras at run-time

Camera application makes use of central repository extensively in order to differentiate the application functionalities and the settings options that it provides for the end users. These CenRep flags can be either set or un-set for a particular product as per the requirement. Here are a few examples:

- **KCamCrAppAlwaysRunningIsOn:** If enabled, Camera application will hide itself and keep running in the background when user selects Exit in the UI. Enabling will increase RAM consumption, but it will greatly improve Camera application start-up latency.
- **KCamCrPhotoStoreLocation:** Store location information in metadata for captured images.
- **KCamCrTimeLapseSupport:** If this flag is set the application will use time lapse functionality, otherwise only burst mode functionality will be available.

## 5.4 Variation with Onboard Camera API

The Symbian onboard camera API, ECam, provides camera interfaces to UI applications and MMF, abstracting the camera hardware underneath. The Symbian camera framework supports any concrete ECam implementation only as an ECom plug-in. The ROM plug-in with the highest version number is selected at instantiation phase.

The Symbian platform has several such ECam plug-ins with proprietary implementations which extend the functionality of concrete APIs. During the ROM image creation phase for a specific device, the appropriate associated flags are used to ensure that the required ECam plug-in is included into the image.

ECAM\_INCLUDE\_NOKIA\_PLUGIN is an important flag in a way that if defined, it includes Nokia's ECam plug-ins into the product ROM image. Nokia implements the real interface to the underlying camera driver with several ECam extension plug-ins. These plug-ins enable face tracking, image rotation, camera orientation, advanced set-

tings for camera application, managing memory buffers for video and possibly JPEG codecs. All these plug-ins are included into the ROM image for a product provided the flag is defined. For some Nokia Symbian products, the complete camera hardware and software stack could be from a 3<sup>rd</sup> party vendor and generally the ECam plug-ins are supplied by them. Those are included into the image if this flag is undefined.

ECAM\_NUMBER\_OF\_CAMERAS is a flag that defines the number of cameras present on the device so that ECam can report it to its clients. Programme 5.2 is a code snippet from Nokia's ECam plug-in that makes use of this flag. This interface function returns the number of cameras on the device. It makes use of variation during compile-time.

```
EXPORT_C TInt NokiaECamVariant::CamerasAvailable()
{
    #if( defined( ECAM_NUMBER_OF_CAMERAS ) )

        //Number of cameras defined for a product.
        #if ( ECAM_NUMBER_OF_CAMERAS == ECAM_NUMBER_OF_CAMERAS_TWO )

            return 2;
        #elif ( ECAM_NUMBER_OF_CAMERAS == ECAM_NUMBER_OF_CAMERAS_ONE )
            return 1;
        #else
            return 0;
        #endif

    #else
        #error Feature flag ECAM_NUMBER_OF_CAMERAS not defined!
    #endif // ECAM_NUMBER_OF_CAMERAS
}
```

Programme 5.2: Returning number of cameras, variation during compile-time

There are several similar compile-time feature flags that Nokia's ECam plug-in implementations are using. ECAM\_PRIMARY\_CAMERA\_HWA flag indicates the type of hardware accelerator used with the main camera. Likewise, the flag that tells about the hardware accelerator used with the secondary camera is ECAM\_SECONDARY\_CAMERA\_HWA. These two flags are set to the values IVE1, IVE3 or IVE<sub>n</sub> depending on the IVE type used with the product. These enable loading and accessing the required IVE drivers to communicate with the camera hardware accelerator. Below are few other interesting flags:

- ECAM\_PRIMARY\_EXIF\_THUMBNAIL\_SIZE is used to select the size of the thumbnail image embedded in Exif files produced by device primary camera.
- ECAM\_CAMEXT\_CAMADVSETTINGS can be defined as supported for primary, secondary, or both cameras. This enables Symbian Onboard Camera API Advanced Settings API implementation.
- ECAM\_CAMEXT\_CAMADVSETTSNAPSHOT enables Symbian Onboard Camera API Advanced Settings API Snapshot extension implementation.
- ECAM\_CAM1\_ECAM\_DSVF Symbian Onboard Camera API direct screen viewfinder type supported for the primary camera.

## 5.5 Variation in Camera Driver

Different camera and flash setups for products within a product family, which are based on the same Symbian OS platform, require variation in the camera application and camera driver software. Compile-time variation flags, which are the pre-processor #define flags, are used to vary the camera driver. This enables a smaller size of the driver DLLs by including only the necessary code into the final driver DLL, thereby causing a smaller memory footprint on the product ROM image. Following are the compile-time variation flags used to configure the camera driver.

### 5.5.1 Flash Module Specific Flags

From flash module perspective, the types of the flash module and the flash driver are the variation points for the camera driver. Generally it is not possible to detect by SW which kind of flash modules are present in the system. Instead this information must be given by using static configuration flags that will control the software execution during the run-time. Following are the configuration flags to enable or disable the functionalities specific to flash modules for a particular product.

Different flash types enable different use cases for imaging purposes. If the flash module is Xenon type then it can be used only for still imaging. Xenon type requires recharging of the Xenon capacitors after each usage. On the other hand LED type can be additionally used for video light purposes as well as for autofocus assistance in low light conditions. LED flash can also be used as a torch light. To tell the system whether it has Xenon, LED, both or no flash at all there is a flag `CAMDRV_MAIN_FLASH_TYPE`.

Different LED and Xenon types produce different colour and intensity of light. This needs to be compensated by using image quality tuning values specific to this flash type when capturing images with flash. To give SW the exact flash HW model information there is a configuration flag called `CAMDRV_MAIN_FLASH_HW`.

For privacy purposes it is required that the phone gives some indication when capturing an image. In some products this is done with a separate indicator LED that blinks during the capture. As it is not possible to detect the presence of the indicator LED by SW, the configuration flag `CAMDRV_SEPARATE_INDICATOR_LED` is needed.

### 5.5.2 Flags for Configuring Primary Camera

The type of the camera, the camera sensor resolution and the type of the camera lens are the primary camera specific variation points for the camera driver. Static configuration flags are used to handle the variation.

A Symbian platform supports several products with varying primary camera HW setup. The primary camera functionality may be handled by either IVE or APE based on the product configuration. The platform contains different set of camera PDDs for each setup. The configuration flag `CAMDRV_MAIN_CAMERA_PDD` provides the

information whether the camera HW is handled by a particular IVE processor or by APE. Based on this information the specific primary camera PDD files are picked into the product ROM image.

Different types of camera sensors pose challenges to the quality of the image that they produce. The image signal processing requires image quality (IQ) tuning parameters to be used in order to correct the anomalies in the images produced by the camera. These image tuning parameters are specific to the camera sensor type. Configuration flag `CAMDRV_PRIMARY_CAMERA_SENSOR_TYPE` provides the information needed to include the correct IQ tuning files into the product ROM image.

Camera LDD must know various camera configuration values like the still image width and height, the camera preview width and height as well as the video resolutions. Based on these configuration values, the driver has to reserve and initialize memory buffers to hold and transfer the image data requested by its clients. The available resolution options for still images and video are queried on run-time from IVE, but the memory buffers must be pre-allocated during compile-time in order to be able to calculate the memory budget required by the imaging components. For example, still image memory buffers are reserved according to the maximum camera sensor resolution defined by flag `CAMDRV_PRIMARY_CAMERA_SENSOR_RESOLUTION`.

`CAMDRV_PRIMARY_CAMERA_FOCUS_SUPPORT` is a Boolean flag that indicates whether the primary camera supports focus feature. This configuration flag is defined only for cameras with AF lens. If this flag is defined then the camera driver enables the focus feature for the main camera and allows its clients to configure different focus modes.

### 5.5.3 Flags for Configuring Secondary Camera

Camera driver has a set of static configuration flags similar to the ones used with the primary camera at its disposal for the secondary camera variation purpose.

The product HW setup could have the secondary camera connected either to APE or to IVE. To fetch the specific camera driver PDD that handles secondary camera on the product the value of the flag `CAMDRV_SECONDARY_CAMERA_PDD` is used.

The flag `CAMDRV_SECONDARY_CAMERA_SENSOR_TYPE`, like its primary camera counterpart, provides the camera driver the information about the type of secondary camera sensor being used on the product. Based on this information the relevant IQ tuning files are included into the product ROM image.

The secondary camera sensor generally has a low pixel count, the typical resolution with Nokia phones being VGA. This information is needed by the camera driver to initialize memory buffers in order to transfer image data from the secondary camera. `CAMDRV_SECONDARY_CAMERA_SENSOR_RESOLUTION` is the flag that provides the sensor pixel count from the secondary camera.



### 5.5.4 Algorithm Specific Configuration Flags

The Symbian platform provides scores of image enhancing and correction algorithm implementations and several options with each of those to choose from. This includes Nokia's in-house implementations and 3<sup>rd</sup> party commercial ISP implementations from various vendors. Based on the product's price point, 3<sup>rd</sup> party algorithm license fee, processing capacity and the type of camera sensors in use a particular product may opt for a specific algorithm implementation.

Below is a list of algorithms and associated variation flags:

- Auto Exposure: CAMDRV\_AE\_ALGORITHM
- Auto Focus: CAMDRV\_AF\_ALGORITHM
- Auto White Balance: CAMDRV\_AWB\_ALGORITHM
- Automatic Motion Blur Reduction: CAMDRV\_AMBR\_ALGORITHM
- Face Detection: CAMDRV\_FD\_ALGORITHM
- Red Eye Removal: CAMDRV\_RER\_ALGORITHM
- Smart ISO: CAMDRV\_SMART\_ISO\_ALGORITHM

Each of these flags could be set to a vendor specific value, so that the ROM image would include that vendor specific implementation into the camera driver. In case that a particular algorithm flag is not defined for a product then the implementation will not be part of the product ROM image.

## 5.6 Case Study with Symbian^3 Products

Symbian^3 products Nokia N8, Nokia 701 and Nokia 603 are considered for the case study. N8 is made with 680MHz APE host processor and the camera HW accelerator from the IVE3 family, whereas Nokia 701 and Nokia 603 are using 1GHz APE with latest version of accelerator chip from IVE3 family namely IVE3.5. The striking feature of N8 is its state of the art camera and the imaging experience it provides to the end user. The N8's primary camera features 12 megapixel image sensor with large pixel size, autofocus lens, mechanical shutter and neutral density filter. The cost of using this uncompromising camera comes as a bigger physical size that causes challenges for the overall design of the phone. The slender Nokia 701 and Nokia 603 are shipped with EDoF cameras with image sensor resolutions 8 and 5 megapixels respectively. While N8 has a powerful Xenon flash to assist still capturing, Nokia 701 has a dual LED flash and Nokia 603 has no flash module at all. N8 and Nokia 701 have front facing secondary camera for video calling, whereas Nokia 603 does not have a front facing camera [20].

This thesis work was done as part of IVE3 software team, so this case study concentrates mostly on the variation of IVE3 software and adaptation layers for it on the APE, alternatively called as the host that runs the Symbian OS. Issues closer to the application layer are handled only superficially. IVE3 and IVE3.5 are collectively known as multi-media accelerator chips from IVE3 family.

IVE3 is the generation of camera and graphics accelerator chip that Nokia incorporates into its Symbian<sup>^3</sup> based products. One of the set goals for the IVE3 was to enable the freedom to select any combination from the supported primary cameras, secondary cameras, flash drivers and flash modules in order to vary new camera phones. To give background information on why the software modularity and effective variation was sought with IVE3, the lack of these with IVE1 is considered briefly here.

IVE1 was the earlier camera accelerator chip solution that Nokia used across its device portfolio based on S60 3.x, and S60 5.0 (Symbian<sup>^1</sup>). IVE1 accelerator chips are Texas Instrument's OMAP digital multimedia co-processors. The problem with IVE1 was that each different combination of cameras, flash drivers and flash modules caused a software branch being created for that particular combination. This led to a situation where making one common correction or update to the IVE software required changes to practically same code over different software branches. Furthermore, a complete testing round was required for each of these software branches. This resulted in high maintenance cost that caused restrictions in making minor improvements and error fixes to the software. As the time went on there were bound to be cases where some of the fixes were forgotten or missed out from some of the software branches. In the end, there were several IVE1 accelerator chip configurations and each of these had their own branches for each camera component combinations. On the other hand, the long life of the IVE1 family camera phones proved the competitiveness of this kind of stand-alone camera accelerator solution at the time. Changing to the next generation of accelerator chip, called as IVE3 inside Nokia, was largely due to its ability to function as complete multimedia co-processor that includes graphics acceleration and display controlling apart from handling camera and flash modules. IVE3 is Brodcom's multimedia processor that provides high quality multimedia features for mobile phones while retaining the long battery life [20]. IVE3 chip based devices can support HD video camcorder and playback, professional high-resolution cameras with advanced ISP, and high-performance 3D for advanced user interfaces, navigation displays, and mobile gaming. To avoid the huge software maintenance cost that IVE1 family of products posed, the software for IVE3 had to be designed to be highly modular using common interfaces between various parts of the system.

The software running in IVE3 multimedia co-processor has been separated from the rest of the phone SW as it is running completely inside the accelerator's own memory and processor. The software is delivered as independent binaries to the phone's Symbian software build, residing in the phone's file system mostly as separate files. The software for IVE3 is built separately from the rest of the phone software using a non-Symbian compiler, thus most of the software variation mechanisms provided by Symbian build process are not statically available when building the IVE3 software. However, for example certain variation flags are sent to IVE3 during the run-time to make certain decisions static in nature. These are for example details relating to flash modules, which are not able to identify themselves through any command interface.

The control and data buses towards the camera and flash driver peripherals are using standardized hardware interfaces and are thus able to use common software device drivers for accessing them. Furthermore, Nokia requires its camera vendors to use standardized, SMIA (and SMIA++) compatible power up sequences so that all cameras can be powered up in a similar manner. The software can then identify the camera dynamically by reading its model and revision identifier registers. After that the camera is known and IVE will request the host to send the appropriate driver file for handling it.

The camera driver resides on top of the bus control layers, and is responsible for handling one certain camera model. It must be able to handle all the different development versions of that camera module. The purpose of the camera driver is to provide access to the camera specific features but at the same time hide the implementation details from the upper SW layers. Despite the SMIA compatibility, the camera modules have usually also some manufacturer specific settings that need to be adjusted according to the use case. These are changing during the development time of the camera module and might be specific to a certain version of the camera. These are handled in the camera driver by having static settings tables separately for each version of the camera. All the camera device drivers implement a common interface through which they can advertise their capabilities to the common imaging framework. For example the camera driver lists the supported camera modes for different use cases like video and still imaging. The mode settings consist of available resolutions and frame rates with binning, cropping and frame output format information.

Camera modules with auto focus lens are equipped with the specific control logic and motor mechanism for actually moving the lens, which is called a lens driver. This same mechanism handles also other moving parts like mechanical shutter and ND filter in case of N8. Similar to the camera driver that handles the camera sensor there is a separate lens driver SW for controlling the lens specific tasks. The required lens driver software for each camera has been listed in the static table of supported cameras. Nokia 701 and Nokia 603 are using EDoF cameras without AF mechanism, so the lens driver has not been specified for them.

For identifying the flash driver HW there is a similar mechanism to the identification of the camera. The requirements for the powering up mechanism are the same for all the flash driver HWs. After powered up the flash driver HW can be queried for its model ID, based on which the correct driver SW can be selected. On the other hand, the actual flash module cannot be identified on run-time by SW, as the flash modules do not generally provide any identification mechanism. Instead, IVE gets the flash module information from the host through static configuration flags.

All these parts of the IVE SW are specific to certain camera component types, yet the major part of the SW implementation is common for all combinations of those. In a central role is the common imaging framework that takes care of general flow of the imaging tasks and loading of the device specific drivers. This framework leaves handling of the device specific requirements for the PDD level, but it must be aware of the specific features that the actual peripherals support. For example it must time the Xenon

charging so that it does not generate any interference to the image frame being exposed. Similarly, it must time the AF lens movement so that it does not disturb the preview frames. The framework also takes care of configuring and controlling of the ISP and the imaging algorithms like auto exposure and auto white balance. The parameters used with these have been tuned separately for each used combination of camera and flash modules. These image quality tuning values are maintained in the module specific DC files. After identifying the used modules the framework requests the corresponding DC file from the host. The ROM image includes all available DC files for the camera and the flash types specified in the product specific feature flags.

Following table lists different variation points specific to the product. The respective feature variation flags are defined in a feature settings header file (for example N8.hrh) to enable the variation for a particular product.

Features	N8	Nokia701	Nokia603
Number of Cameras	2	2	1
Main Camera	A	B	C
Main Sensor Resolution	12MP	8MP	5MP
Main Camera Focus Support	True	False	False
Secondary Camera	D	D	None
Secondary Camera Resolution	VGA	VGA	None
Main Flash Driver	X	L	None
Main Flash HW	Xenon	LED	None
Separate Indicator LED	True	True	False
IVE HW	IVE3	IVE3.5	IVE3.5

These camera system feature flags are visible to the whole Symbian software. Building the Symbian software platform for a particular phone configuration will result in the phone specific camera software components, the camera application, the ECam library and the camera driver.

Following are the typical camera component binaries generated under the Symbian platform's epoc32 tree for the products of this case study. Camera application uses runtime variation, hence the same executable binary is used with all the products. N8 includes the camera application developed with Symbian's traditional GUI development framework AVKON.

```
\epoc32\release\CameraApp.exe
```

QT based GUI applications for Symbian<sup>^3</sup> became available after N8 had been released to the market. QT provides a simplified application asset, enabling easier application development and maintenance compared to AVKON. The post N8 products, Nokia 701 and Nokia 603 include the QT camera application that provides improved UI controls compared to AVKON applications. However, both the applications are valid and work with all the Symbian<sup>^3</sup> products.

`\epoc32\release\QTCameraApp.exe`

ECam typically includes several plugins that provide interface to its clients such as UI applications.

`\epoc32\release\N8\ECamPlugin.dll`  
`\epoc32\release\N8\ECamExtPlugin.dll`  
`\epoc32\release\Nokia701\ECamPlugin.dll`  
`\epoc32\release\Nokia701\ECamExtPlugin.dll`  
`\epoc32\release\Nokia603\ECamPlugin.dll`  
`\epoc32\release\Nokia603\ECamExtPlugin.dll`

The camera driver LDDs provide an abstract interface to the IVE HW, the camera and the flash modules.

`\epoc32\release\N8\CamDriver_IVE3.ldd`  
`\epoc32\release\Nokia701\CamDriver_IVE3.ldd`  
`\epoc32\release\Nokia603\CamDriver_IVE3.ldd`

PDDs that provide interface to the IVE HW and its peripherals:

`\epoc32\release\IVE3\IVEDriver.pdd`  
`\epoc32\release\IVE3.5\IVEDriver.pdd`

The camera PDDs that provide interface to a particular camera:

`\epoc32\release\IVE3\MainCamA.pdd`  
`\epoc32\release\IVE3\MainCamALens.pdd`  
`\epoc32\release\IVE3.5\MainCamC.pdd`  
`\epoc32\release\IVE3\SecCamD.pdd`  
`\epoc32\release\IVE3.5\SecCamD.pdd`

Procuring camera modules from several vendors benefits Nokia to have a second source for cameras. This helps Nokia to increase the camera volumes if required more easily when there is more capacity on the vendor side. Though the camera manufacturers follow SMIA standard and the cameras are of the same type, they may offer different programming registers and hence require different vendor specific PDD camera drivers. With the current variation setup, all the vendor specific camera PDDs are included into the ROM image. Thus Nokia 701, which utilizes the 8MP EDoF cameras from vendorX and vendorY, requires camera specific PDDs for both of them. This increases the ROM image size of the product, but it cannot be avoided because it must be possible to use either of the cameras on the production line or in the service center. Using different SW in each case would be too expensive from the SW logistics point of view. Here are the vendor specific PDD files:

```

\epoc32\release\IVE3.5\XMainCamB.pdd
\epoc32\release\IVE3.5\YMainCamB.pdd

```

The dynamic configuration (DC) files for different camera setups:

```

\epoc32\release\dc\camA_Xenon.dc
\epoc32\release\dc\camB_LED.dc
\epoc32\release\dc\camC.dc
\epoc32\release\dc\camD.dc

```

On ROM image creation for Nokia 701, only the product specific binaries are picked in to the image. Those executables and libraries sit into the ROM aka Z: drive of the device.

\epoc32\release\QTCameraApp.exe	z:\system\bin\QTCameraApp.exe
\epoc32\release\Nokia701\ECamPlugin.dll	z:\system\bin\ECamPlugin.dll
\epoc32\release\ Nokia701\ECamExtPlugin.dll	z:\system\bin\ECamExtPlugin.dll
\epoc32\release\ Nokia701\CamDriver_IVE3.ldr	z:\system\bin\CamDriver_IVE3.ldr
\epoc32\release\IVE3.5\IVEDriver.pdd	z:\system\bin\IVEDriver.pdd
\epoc32\release\IVE3.5\XMainCamB.pdd	z:\system\bin\XMainCamB.pdd
\epoc32\release\IVE3.5\YMainCamB.pdd	z:\system\bin\YMainCamB.pdd
\epoc32\release\IVE3.5\SecCamD.pdd	z:\system\bin\SecCamD.pdd
\epoc32\release\dc\camB_LED.dc	z:\system\dc\camB_LED.dc
\epoc32\release\dc\camD.dc	z:\system\dc\camD.dc

Figure 5.4 illustrates the Symbian^3 camera system as viewed from HW and SW sides. The HW setup for the three products differ as explained earlier in this section. From the SW perspective there is a clear process execution boundary between IVE and APE. All the PDDs, codecs and algorithms run on IVE side whereas the LDD, the ECam plugins and the components from the application level run on APE side. The camera system LDD runs in the kernel privileged mode on APE and rest of the components run in the user privileged mode.

Symbian^3 application framework evolved radically with QT based application development support. QT applications provide intuitive user interface with improved UI icons compared to Symbian's traditional AVKON framework. However, applications for Symbian^3 products can be developed with either of the UI frameworks independent from the rest of the Symbian SW stack. N8, being the product from pre QT times, contains the AVKON based camera application and associated application engines. Nokia 701 and Nokia 603 include the QT based GUI application for accessing camera.

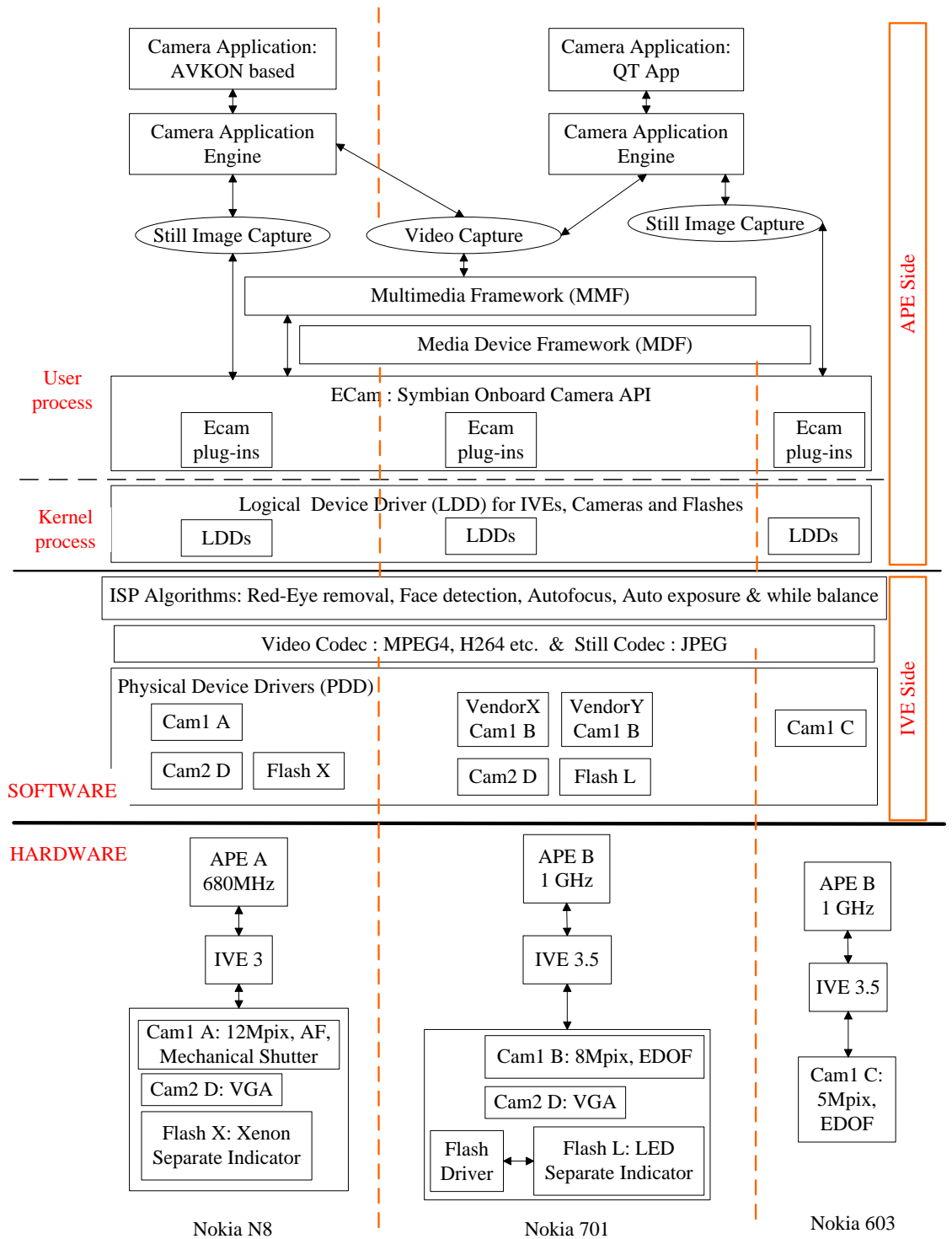

Figure 5.4: Camera system variation within N8, Nokia 701 and Nokia 603

## 6 CONCLUSION

Nokia has to differentiate its mobile phone offerings in order to provide devices across wider price range with different market requirements and thereby to lead the competition. Besides, the rapidly advancing camera and flash HW technology necessitates Nokia to be fast enough in updating its camera system within its devices.

The Symbian OS platform for mobile phones has evolved over the time adapting to changing HW configurations and application frameworks. Symbian OS supports several SW variation mechanisms through the static (compile-time) and the dynamic (run-time) variation principles. This has enabled the components from Symbian SW stack to vary in order to support the products with differing HW configurations and application frameworks. The aim of this thesis was to describe different possible camera system hardware configurations that Nokia incorporates in its Symbian OS based mobile phones and to explain how the OS platform variation mechanisms are used for supporting those configurations.

The main software components of the Symbian camera system are the camera application providing the user interface, the ECam library providing the APIs to access the onboard cameras and the camera device drivers handling the camera HW. The Symbian camera application is made portable across scores of devices with different camera system configurations by using CenRep, feature discovery APIs as well as ECam's APIs so as to decide the variation points at run-time. On the other hand, the ECam and the camera device drivers make use of the product specific static feature flags during compile-time, thereby creating product specific binaries. The compile-time variation produces smaller sized modular binary files of ECam and camera device drivers, thereby taking less memory space in the product's ROM image. Building the whole Symbian platform produces ROM images for each of the product variants that it supports.

Symbian^3 platform introduced IVE3 range of imaging and video engines supporting variety of camera system configurations for Nokia's premium mobile devices. The goals set for IVE3 in variation point of view were reached quite well. The phone programs are free to select their camera system setup from the supported camera and flash HW options. Though adding support for a new type of camera or flash HW is not a minor effort, it can be done isolated from the rest of the system. From testing point of view, each camera and flash type needs to be fully tested only in one product. For other products with the same camera or flash it is sufficient to run a quick sanity check by executing a reduced test set. This helped in speeding up the updates and in ensuring the testing capability required for the devices.



## REFERENCES

- [1] Gartner Newsroom Press Releases [WWW]. Accessed: 23<sup>rd</sup> June 2011.  
<http://www.gartner.com/it/page.jsp?id=1543014>
- [2] Nokia Symbian^3 Developer's library v1.1 and S60 5th Edition C++ Developer's Library v2.1 [WWW]. Accessed: 23rd June 2011.  
<http://library.developer.nokia.com>
- [3] Insider Guide to Mobile. The Customers, Services, Apps, Phones and Business of the Newest Trillion Dollar Market. By Tomi T Ahonen. Published by TomiAhonen Consulting, 20.10.2010. Free eBook, downloaded from web store: [www.lulu.com](http://www.lulu.com)
- [4] Nokia Products [WWW]. Accessed: 23rd June 2011.  
<http://europe.nokia.com/find-products>
- [5] Nokia C7 camera review from all about Symbian. Accessed on 23rd June 2011.  
[http://www.allaboutsymbian.com/reviews/item/12253\\_Nokia\\_C7\\_review\\_part\\_2\\_Camera\\_.php](http://www.allaboutsymbian.com/reviews/item/12253_Nokia_C7_review_part_2_Camera_.php)
- [6] The Symbian OS Architecture Sourcebook - Design and Evolution of a Mobile Phone OS. By Ben Morris (ISBN: 978-0-470-01846-0)
- [7] SMIA Overview [WWW]. Accessed 23rd June 2011  
[http://read.pudn.com/downloads95/doc/project/382834/SMIA/SMIA\\_Introduction\\_and\\_overview\\_1.0.pdf](http://read.pudn.com/downloads95/doc/project/382834/SMIA/SMIA_Introduction_and_overview_1.0.pdf)
- [8] CZARNECKI, K., AND EISENECKER, U. Generative Programming: Methods, Tools, and Applications. Addison-Wesley, 2000.
- [9] SOMMERVILLE, I. Software Engineering, 6th ed. Addison-Wesley, 2001.
- [10] KRUEGER, C. Variation management for software production lines. In Proceedings of the 2nd International Software Product Line Conference (San Diego, California, USA, August 2002), Lecture Notes in Computer Science. Vol. 2379, pp. 37–48.

- [11] BERCHUK, S. P., AND APPLETON, B. Software Configuration Management Patterns: Effective Teamwork, Practical Integration. Addison-Wesley, 2002.
- [12] Nokia product camera specifications [WWW]. Accessed: 20th June 2011. <http://blogs.nokia.com/nseries/>
- [13] MARTIN, R. C. Agile Software Development, 2nd ed. Addison-Wesley, 2002.
- [14] FOWLER, M. Refactoring: Improving the Design of Existing Code. Addison-Wesley, 1999.
- [15] J. Nakamura, Image Sensors and Signal Processing for Digital Still Cameras. CRC Press, 2006.
- [16] G. Saxby, The Science of Imaging: An Introduction. IoP Publishing, 2002.
- [17] O. Kalevo. (2008) Advanced Camera and Optics. Nokia. Training material.
- [18] V. Nummela. (2008) Camera Lenses. Nokia. Training material.
- [19] O. Kalevo. (2008) Imaging Pipe Description: From Sensor Data to an Image. Nokia. Training material.
- [20] Nokia Device specifications [WWW]. Find the phone you want to develop for. Accessed: 20th January 2012 [http://www.developer.nokia.com/Devices/Device\\_specifications/](http://www.developer.nokia.com/Devices/Device_specifications/)