



TAMPEREEN TEKNILLINEN YLIOPISTO
TAMPERE UNIVERSITY OF TECHNOLOGY

ANTTI MÄNNISTÖ
A STUDY OF HARDWARE ACCELERATION IN SYSTEM ON CHIP
DESIGNS USING TRANSPORT TRIGGERED ARCHITECTURE

Master of Science Thesis

Examiner: Prof. Jarmo Takala
Examiner and topic approved in the
faculty of Computing and Electrical
Engineering Council meeting
9th of March 2016

ABSTRACT

ANTTI MÄNNISTÖ: A Study of Hardware Acceleration in System on Chip Designs using Transport Triggered Architecture

Tampere University of Technology

Master of Science Thesis, 47 pages, 1 Appendix page

June 2016

Master's Degree Programme in Electrical Engineering

Major: Embedded Systems

Examiner: Professor Jarmo Takala

Keywords: Transport Triggered Architecture, LTE, Fast Fourier Transform, FFT

Transport Triggered Architecture is a processor design philosophy where the datapath is visible for the programmer and the program controls the data transfers on the path directly. TTA processors offer a good alternative for application specific task as they can be easily optimized for a given application. TTA processors, however, adjust poorly to dynamic situations, but this can be compensated with external hosting.

Fast Fourier transform is an approximation of the Fourier transform for converting time domain data into frequency domain. Fast Fourier transform is needed in many digital signal processing applications. One example of the usage of the transform is the LTE network access schemes where the symbols transmitted over the air interface are constructed with the fast Fourier transform and again de-modulated as they are received.

The study makes use of Nokia Co-Processor as the host for TTA processor and proposes alternatives for different architectures for the usage of the TTA processor inside a practical design where data is being moved over interconnections and memories. One proposed architecture is selected for implementation and the construction of this architecture is discussed regarding implementing the needed hardware and software to run the Fourier application on TTA with data being fetched and written back in system memory. Lastly, the performance of the implementation is discussed.

TIIVISTELMÄ

ANTTI MÄNNISTÖ: Tutkimus laitteistokiihdytyksestä järjestelmäpiireillä käyttäen siirtoliipaistua arkkitehtuuria
Tampereen teknillinen yliopisto
Diplomityö, 47 sivua, 1 liitesivu
Kesäkuu 2016
Sähkötekniikan koulutusohjelma
Pääaine: sulautetut järjestelmät
Tarkastaja: professori Jarmo Takala

Avainsanat: siirtoliipaistu arkkitehtuuri, LTE, nopea Fourier-muunnos, FFT

Siirtoliipaistu prosessoriarkkitehtuuri on prosessorisuunnittelufilosofia, jossa datapolku näkyy ohjelmoijalle ja ohjelma kontrolloi suoraan datapolun datasiirtoja. TTA prosessorit tarjoavat hyvän vaihtoehdon sovellusspesifeille tehtäville, sillä ne voidaan helposti optimoida suoritettavalle sovellukselle. TTA prosessorit sopeutuvat kuitenkin huonosti dynaamisiin tilanteisiin, mitä voidaan kuitenkin kompensoida ulkoisella ohjauksella.

Nopea Fourier-muunnos on Fourier-muunnoksen approksimaatio datan muuntamiseksi aikatasosta taajuustasoon. Nopeaa Fourier-muunnosta tarvitaan useissa digitaalisten signaalien prosessointisovelluksissa. Yksi esimerkki muunnoksen käytöstä on LTE-verkkoon pääsy, jossa ilmarajapinnan yli lähetettävät symbolit konstruoidaan nopeaa Fourier-muunnosta käyttäen ja edelleen demoduloidaan vastaanotettaessa.

Tämä tutkielma hyödyntää Nokian apuprosessoria ulkoisena ohjauksena TTA-prosessorille ja ehdottaa vaihtoehtoja eri arkkitehtuureille TTA prosessorin käyttämiselle käytännön piirissä, jossa data siirretään väylien ja muistien kautta. Yksi ehdotettu arkkitehtuuri valitaan toteutettavaksi ja tämän arkkitehtuurin konstruointi käydään läpi koskien tarvittavan raudan ja ohjelmiston toteuttamista Fourier sovelluksen ajamiseksi TTA:lla siten, että data haetaan ja kirjoitetaan takaisin systeemimuistiin. Lopuksi käydään läpi toteutuksen suorituskykyä.

PREFACE

This thesis was done at Nokia Networks in Tampere, Finland, in spring 2016.

Many people at Nokia helped me with this thesis somewhere along the journey, and I thank you all for the support and assistance. Special and warm thanks to Jari Heikkinen for introducing me with the TTA processor and for providing me the first hand help, advices and instructions. I also want to thank my examiner, Jarmo Takala, for the valuable and irreplaceable comments and instructions regarding my work, and Lasse Lehtonen for providing the TTA processor used in this study.

As one chapter ends, a new one begins.

Tampere 25.5.2016

Antti Männistö

TABLE OF CONTENTS

1. INTRODUCTION	1
2. FREQUENCY DIVISION MULTIPLEXING IN WIRELESS COMMUNICATIONS.....	3
2.1 Fast Fourier Transform.....	3
2.2 Long Term Evolution Standard.....	6
2.2.1 Overview	6
2.2.2 Frequency Division Multiplexing	8
3. PROCESSOR TEMPLATES.....	11
3.1 Transport Triggered Architecture.....	11
3.2 Nokia Co-Processor.....	13
4. ARCHITECTURAL ALTERNATIVES	15
4.1 Single COP System: DMA Control over the System Interconnect.....	15
4.2 Single COP System: DMA Control over the Auxiliary Interface.....	21
4.3 Dual COP System.....	25
4.4 Performance Comparison	26
5. IMPLEMENTATION	28
5.1 Top Level Design	28
5.2 COP Configuration.....	29
5.3 Auxiliary Units	29
5.3.1 Interfaces	29
5.3.2 Transaction Protocol	31
5.3.3 Datapath	33
5.3.4 State Diagrams	35
5.3.5 Buffers.....	37
5.3.6 TTA Control.....	38
5.4 TTA Processor.....	39
5.5 Memories.....	40
5.6 COP Software.....	41
6. RESULTS	45
7. CONCLUSION	46
REFERENCES.....	47

APPENDIX A: IMPLEMENTED TTA PROCESSOR ARCHITECTURE

ABBREVIATIONS

3GPP	3 rd Generation Partnership Project
ALU	Arithmetic logic unit
AMBA	Advanced Microcontroller Bus Architecture
ASIC	Application-specific integrated circuit
ASIP	Application-specific instruction-set processor
AUT	Auxiliary Unit Transceive block
AUX	Auxiliary (refers to Auxiliary port)
COP	Nokia Co-Processor
CPU	Central processing unit
DFT	Discrete Fourier transform
DIT	Decimation-in-time
DIF	Decimation-in-frequency
DMA	Direct memory access
DSP	Digital signal processing
EDGE	Enhanced Data Rates for GSM Evolution
eNB	Evolved-Node B
EPS	Evolved Packet System
FFT	Fast Fourier transform
FIFO	First-in-first-out
FU	Functional unit
GCU	Global control unit
GERAN	GSM EDGE Radio Access network
GPRS	General Packet Radio Service
GSM	Global System for Mobile Communications
IC	Interconnect
IFFT	Inverse fast Fourier transform
IP	Intellectual property
LSU	Load-store-unit
LTE	Long Term Evolution
OFDM	Orthogonal Frequency Division Multiplexing
OFDMA	Orthogonal Frequency Division Multiple Access
QAM	Quadrature amplitude modulation
R4SDF	Radix-4 single-path delay feedback
RAM	Random access memory
RF	Register file
RISC	Reduced instruction set computer
SC-FDMA	Single Carrier Frequency Division Multiple Access
SoC	System on chip
SR	Shift register
TCE	TTA-based Co-Design Environment
TDMA	Time Division Multiple Access
TTA	Transport Triggered Architecture
UMTS	Universal Mobile Telecommunications System
UTRAN	UMTS Radio Access Network
VLW	Very long instruction word
VHDL	VHSIC hardware description language
VHSIC	Very high speed integrated circuit
WCDMA	Wideband Code Division Multiple Access

1. INTRODUCTION

Moore's law for the amount of transistors inside integrated circuits has stayed accurate for the last 40 years and systems on chip (SoC) contain more logic than ever. Although Moore's law is starting to gradually slow down as the manufacturing technologies are reaching their lower limits, the complexity of microchips is not saturating. The number of cores inside chips is increased and parallelism is utilized on higher levels, increasing the complexity even if the technology stays the same.

With the ever increasing complexity, it's getting harder to design products with no faults. Humans make mistakes and these can potentially be carried all the way inside a product released on the market in spite of all the testing and verifying done along with the design process. This proposes a serious problem in hardware design, especially with application-specific integrated circuits (ASIC); once the faulty chip has been manufactured it is impossible to erase the error from the hardware. Therefore, any kind of additional programmability being able to include inside the designs comes with great value, if the faults in hardware can be bypassed.

Many algorithms in digital signal processing (DSP) are too heavy to be ran by software on a general purpose processor, especially in applications with real-time or near real-time requirements, and have to be executed on a separate hardware accelerators. Application-specific instruction-set processors (ASIP) provide a tradeoff between the programmability of a general purpose processor and the efficiency of hardware acceleration. ASIPs are tailored for a specific application only and are usually not suitable for other tasks.

The Transport Triggered Architecture (TTA) concept offers an interesting choice for ASIP implementations. In TTA, the datapath of the processor is exposed for programmer and the program performs data transfers between logical units inside the processor. TTA processors can be optimized for a specific task for high performance, with the benefit of the possibility of being re-programmed for a new use case. TTA processors have the drawback of being inefficient with non-predefined situations, such as interrupts and memory accesses, where the exact timing of the operation is unknown.

In this thesis, the usage of a TTA processor in practical design is studied with compensating the inefficiencies of TTA with Nokia Co-Processor (COP). The use case for this dual processor approach, the *fast Fourier transform* (FFT) in Long Term Evolution (LTE) standard, is first introduced in Chapter 2. The two processors used in this study are presented in Chapter 3, and three proposed architectures for the implementation are discussed

in Chapter 4 regarding their performance. One of the presented architectures was implemented and the design is presented in Chapter 5. The performance of the implemented architecture is discussed in Chapter 6.

2. FREQUENCY DIVISION MULTIPLEXING IN WIRELESS COMMUNICATIONS

In radio networks and signal processing, there is typically a need for transferring data from time to frequency domain and vice versa. Information is modulated into the carrier signals which are transmitted over the air interface as a function of time. Modulating information into several frequencies at the transmit side and de-modulating the data at the receive side demands a method for the time-frequency transform.

In this chapter, the *discrete Fourier transform* (DFT) algorithm of the famous Fourier transform theorem is presented. As an example of the usage of the DFT in modern radio networks, the Long Term Evolution functionality is shortly from the DFT perspective.

2.1 Fast Fourier Transform

The mathematical way for representing a continuous time domain function $f(t)$ in frequency domain is the famous *Fourier integral* or *Fourier transform*

$$F(\omega) = \int_{-\infty}^{\infty} f(t)e^{-j\omega t} dt, \quad (2.1)$$

where $\omega = 2\pi f$ is the angular frequency and $j = \sqrt{-1}$ is the imaginary unit [1]. For digital applications, a discrete version of the transform in an algorithmic representation is needed. The discrete Fourier transform is an approximation of the Fourier transform. The DFT $X(k)$ for input sequence $x(n)$ presented in [2] is defined as

$$X(k) = \sum_{n=0}^{N-1} x(n)W_N^{nk} \quad 0 \leq k < N, \quad (2.2)$$

where N is the number of input samples and the coefficient $W_N = e^{-\frac{j2\pi}{N}}$ is commonly referred as the *twiddle factor*.

In practical use, the number of the input samples N of the DFT often becomes an issue. The DFT sizes can easily be in the scale of 1000 input samples or larger. According to (2.2), the amount of multiplications done in one DFT operation is N^2 , so with 1000 inputs there are 1000 000 multiplications in a single DFT. From hardware point of view this becomes problematic since multiplication units are very costly in area and speed in digital designs.

Resolving the performance issues of the traditional DFT, the fast Fourier transform was first introduced by Cooley and Tukey in 1965 [3]. Size N DFT inputs can be split into two $N/2$ even and odd sequences:

$$x_0(n) = x(2n), \quad n = 0, \dots, \frac{N}{2} - 1 \quad (2.3)$$

$$x_1(n) = x(2n + 1), \quad n = 0, \dots, \frac{N}{2} - 1. \quad (2.4)$$

The DFT in (2.2) can then be re-written as

$$X(k) = \sum_{n=0}^{\frac{N}{2}-1} x(2n)W_N^{2nk} + \sum_{n=0}^{\frac{N}{2}-1} x(2n+1)W_N^{2(n+1)k}. \quad (2.5)$$

Also

$$W_N^2 = \left(e^{-\frac{j2\pi}{N}} \right)^2 = e^{-\frac{j2\pi}{\frac{N}{2}}} = W_{N/2}, \quad (2.6)$$

so (2.5) assumes the form

$$X(k) = \sum_{n=0}^{\frac{N}{2}-1} x_0(n)W_{N/2}^{nk} + W_N^k \sum_{n=0}^{\frac{N}{2}-1} x_1(n)W_{N/2}^{nk} = X_0(k) + W_N^k X_1(k), \quad 0 \leq k < \frac{N}{2}. \quad (2.7)$$

The terms $X_0(k)$ and $X_1(k)$ represent two $N/2$ -point DFTs for input sequences $x_0(n)$ and $x_1(n)$. The form in (2.7) is, however, for size $N/2$ only. Since $X_0(k)$ and $X_1(k)$ are periodic and $W^{k+N/2} = -W^k$, (2.7) can be expressed as

$$X(k + N/2) = X_0(k) - W_N^k X_1(k), \quad 0 \leq k < \frac{N}{2}. \quad (2.8)$$

The previous DFT decomposition is called *decimation-in-time* (DIT) and (2.7) and (2.8) are referred as *butterfly operations*. The principle of 8-point DIF FFT is illustrated in Figure 2.1. The 8-point DFT is split into two different 4-point DFTs for the even and odd inputs. The grey boxes indexed 0...3 represent the twiddle factor multiplications and the sum operations with.

With N being the size of power of 2, the DFT can be constructed with $\log_2 N$ stages where each stage contains $N/2$ butterfly operations. This kind of DFT is referred as *radix-2 FFT* since every DFT operation is done with 2-point operation. An example of 8-point Radix-2 FFT is shown in Figure 2.2. The grey boxes indicate the butterfly operations for each stage, with the number corresponding to exponent k in W_N^k .

The inputs are even-odd paired recursively first for all the 8 inputs, then again for the 4 inputs for the 2-point DFTs. The input sequence $\{x(0), x(1), x(2), x(3), x(4), x(5), x(6), x(7)\}$ is first decimated into $\{x(0), x(2), x(4), x(6)\}$ and $\{x(1), x(3), x(5), x(7)\}$ (as was with the DFT in Figure 2.1) and then again into pairs $\{x(0), x(4)\}$, $\{x(2), x(6)\}$, $\{x(1), x(5)\}$ and $\{x(3), x(7)\}$.

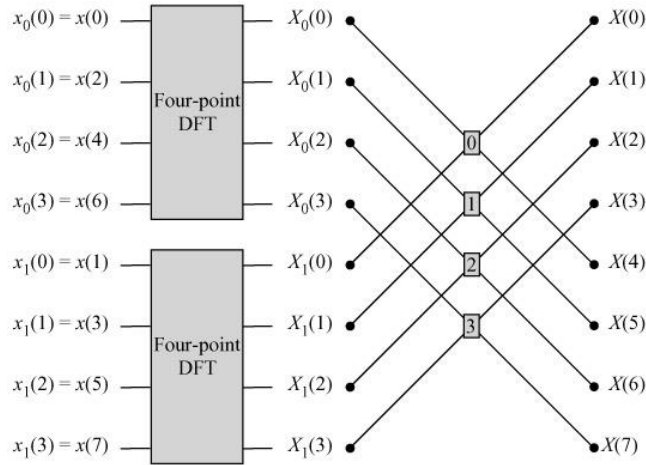

Figure 2.1. 8-point FFT [2, Fig. 19.4].

The idea behind the radix-2 algorithm can be extended to other radices as well. For example *radix-4 FFT* is constructed with 4-point DFTs. With this approach the FFT size N has to be a power-of-two.

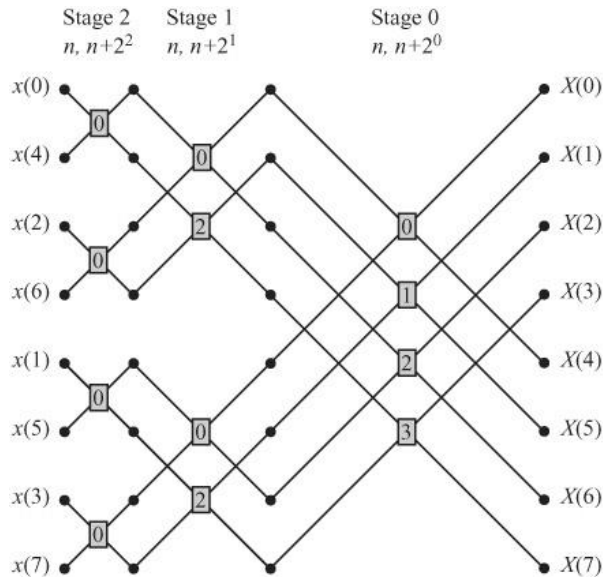

Figure 2.2. 8-point Radix-2 FFT [2, Fig. 19.5].

Another approach for FFT would be *Decimation-in-Frequency* (DIF). The principle of DIF is shown in Figure 2.3 for 8-point FFT. Rather than dividing the input into two 4-point DFTs, the input is divided into four 2-point DFTs.

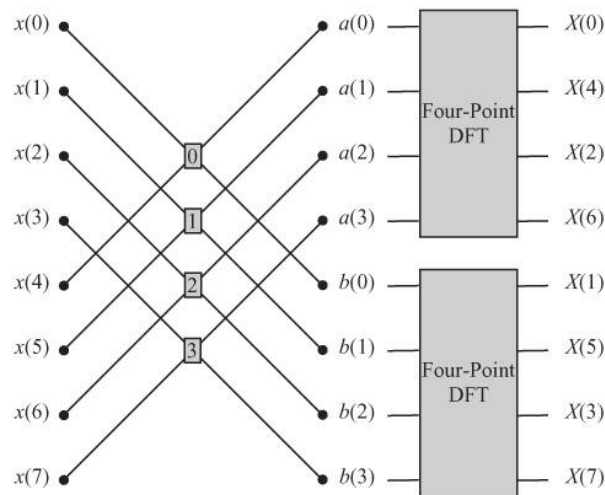

Figure 2.3. Decimation-in-Frequency for 8-point FFT [2, Fig. 19.9].

2.2 Long Term Evolution Standard

The 3rd Generation Partnership Project (3GPP) is a global initiative that provides technical specifications and reports defining telecommunications standards [4]. These standards cover cellular telecommunication network technologies e.g. radio access and the core transport network.

The first basis for the LTE network technologies was described in the 3GPP Release 8 frozen in 2008 [5]. The Releases are updated constantly and most recent technical documentation can be found in Release 13 [6].

2.2.1 Overview

Ever since the first smartphones started taking over the mobile device markets, the amount of mobile data traffic has expanded rapidly and keeps on rising. For example Cisco forecasts the mobile data traffic to reach 30.6 EB per month until the end of this decade [7]. The user demands for higher data rates have been growing along with the data traffic and new technologies has to be taken into use for covering them.

The differences between the old and new radio network solutions are illustrated in Figure 2.4. The early standard Global System for Mobile Communications (GSM) was based on circuit switching and carried real time services. With circuit switching, only low data rates are possible and packet switching was needed to carry data more efficiently. General Packet Radio Service (GPRS) was developed beside GSM to provide the IP-address based packet switched solution and later the GSM/GPRS was improved with Enhanced Data Rates for GSM Evolution (EDGE). The network access for these standards are based on Time Division Multiple Access (TDMA) method. The access network is referred as GSM EDGE Radio Access network (GERAN).

The third generation Universal Mobile Telecommunications System (UMTS) is based on the GSM standard. The access network is referred as UMTS Radio Access Network (UTRAN). It emulates circuit switching technology for real time services and packet switching for IP based data traffic. The access technology is Wideband Code Division Multiple Access (WCDMA) and it allows higher data rates compared to TDMA.

The Long Term Evolution network uses Orthogonal Frequency Division Multiple Access (OFDMA). With LTE, a high order modulation, up to 64 Quadrature Amplitude Modulation (QAM), and wide 20 MHz bandwidth are used for high data rates, achieving a theoretical 300 Mbps rate in downlink and 75 Mbps in uplink direction. In LTE, there is no separate circuit and packet switching functionality as with the older standards and, therefore, no longer need to maintain two separate core networks because the Evolved Packet System (EPS) of LTE is purely IP based.

The LTE access network is a base station network, shown in Figure 2.5. There is no central controller, but the control has been divided between the base stations (evolved-Node B, eNB) for speeding up the setup for the connections. The base stations are connected together with so called X2-interface and to the core network with the S1-interface.

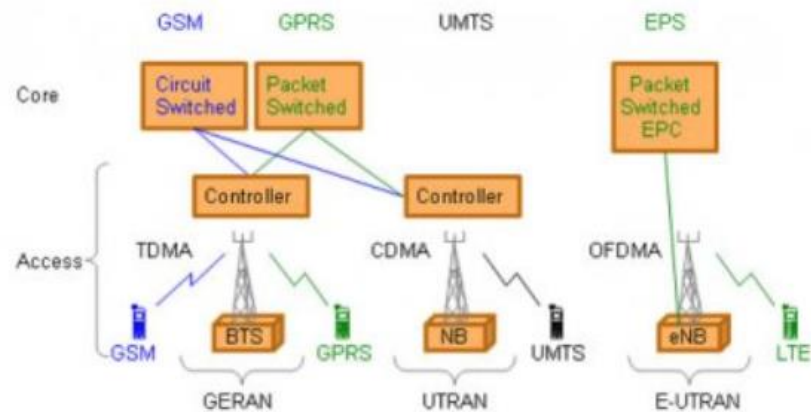

Figure 2.4. From GSM to LTE [5].

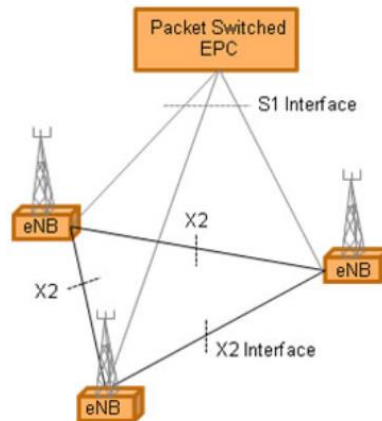

Figure 2.5. LTE access network structure [5].

2.2.2 Frequency Division Multiplexing

As described in the previous section, different network standards use different kind of access techniques for network accessing. In LTE, two multiple access modulation schemes are used: the OFDMA in the downlink direction and the Single Carrier Frequency Division Multiple Access (SC-FDMA) in the uplink direction, as described in [8]. Both are based on the functionality of Orthogonal Frequency Division Multiplexing (OFDM) where the spacing of the *subcarriers* of the frequency band is arranged orthogonally, as illustrated in Figure 2.6. The frequency $1/T_u$ represents the modulation rate per subcarrier. With the orthogonality the overlapping of the subcarriers can be removed.

In OFDM, the transmission bandwidth is divided into relatively large number of N orthogonal subcarriers. The principle is illustrated in Figure 2.7. The frequency axis represent the used N subcarriers that are modulated with *data symbols* $a_k^{(m)}$, with k indicating the subcarrier and m the index of the *OFDM symbol* the data is related to.

In OFDMA, each subcarrier carries information related to different data symbol and the data is being sent for relatively long time. In SC-FDMA, however, each subcarrier carries data related one data symbol only, i.e. one data symbol modulates all the subcarriers, and the data is being sent for relatively short time. Referring again to Figure 2.7, with OFDMA symbols being transmitted the subcarriers are modulated with different data symbols $a_k^{(m)}$ and with SC-FDMA symbols all the subcarriers are modulated with the same data symbol.

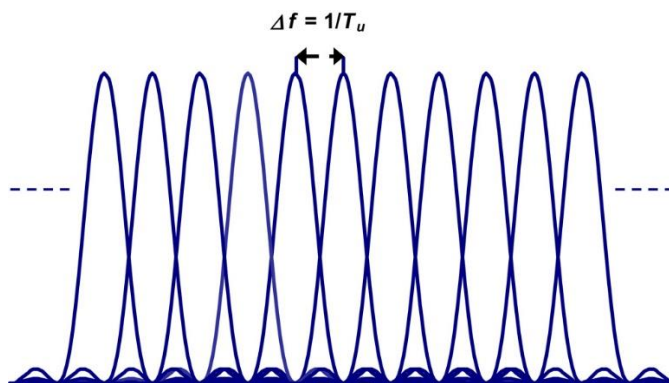

Figure 2.6. Orthogonal subcarrier spacing [8, Fig.3.2].

The FFT processing, described in section 2.1, is used with the OFDM symbols demodulation. The principle is shown in Figure 2.8. The received time domain signal $r(t)$ is sampled into N inputs for the FFT operation with sampling rate $1/T_S$. The serial samples are converted into parallel form for the FFT processing. The FFT engines are usually implemented for the size 2^n to achieve the benefits of the effective radix- n solution for the operation, but this is not always the size exact size of the data being transmitted over the air interface. The data is *zero-padded* into the 2^n -size form and the zeros are removed after the FFT operation.

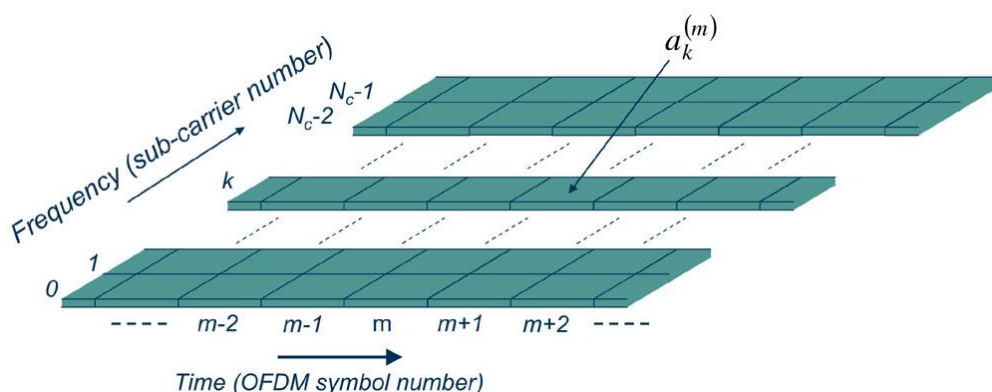

Figure 2.7. OFDM time-frequency grid [8, Fig.3.4].

The FFT is used on the receiver side in LTE but there is also *inverse fast Fourier transform* (IFFT) used in the transmitter side for generating the OFDMA and SC-FDMA symbols. The IFFT performs the opposite functionality relating the FFT, i.e. transforms data from frequency domain to time domain. The principle of the OFDM symbol generation, i.e. the data modulation is shown in Figure 2.9. The modulating data symbols a_k are transferred into parallel form and the IFFT operation is performed. The time domain format data is serialized and transferred for radio transmitter after converted into analog form.

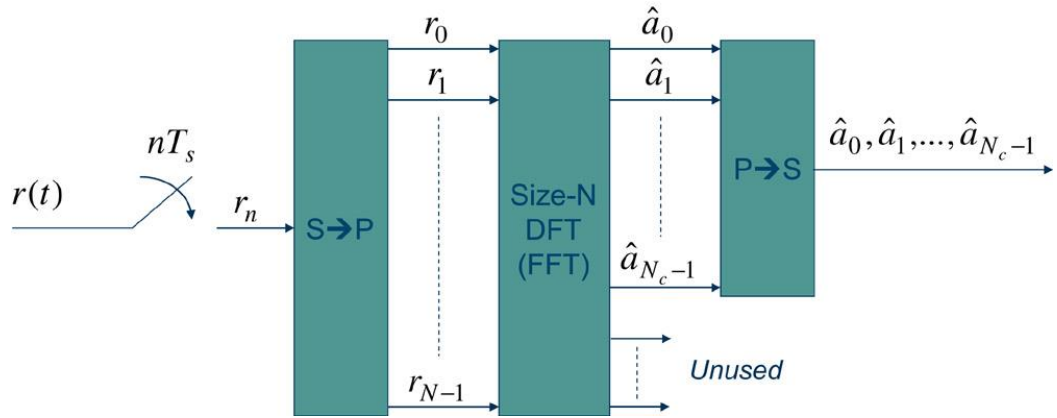

Figure 2.8. OFDM demodulation [8, Fig.3.7].

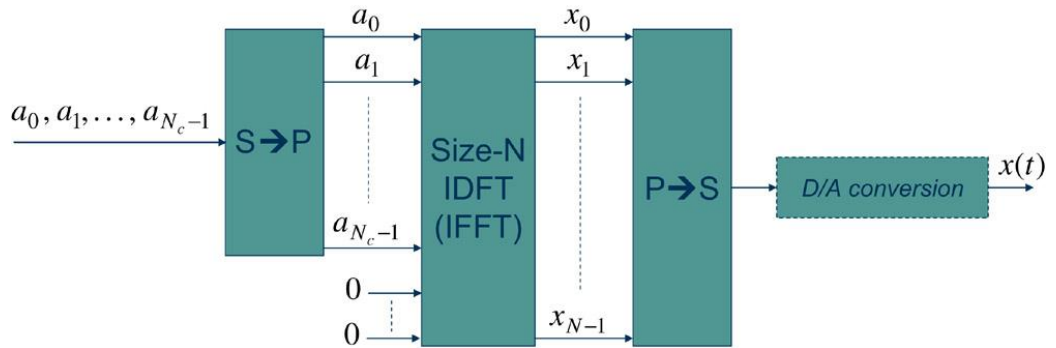

Figure 2.9. OFDM modulation [8, Fig.3.6].

3. PROCESSOR TEMPLATES

Transport Triggered Architecture offers an interesting alternative for completely fixed hardware solutions inside SoCs due to its benefits, such as flexibility and programmability. The resources available inside the TTA processor can be very easily be allocated for new tasks when in need just by loading new program image to the instruction memory of the processor.

Transport Triggered Architecture can be, however, inefficient as a standalone, general purpose processors, because for example interrupt handling is very difficult due to the structure of TTA. In general, the platform is not good with dynamic solutions, but these drawbacks are possible to compensate with external control

In this chapter, the Transport Triggered Architecture is shortly introduced for demonstrating its possibilities and weaknesses inside SoC. Also, the Nokia Co-Processor is presented as a proposal for the host processor for TTA.

3.1 Transport Triggered Architecture

The Transport Triggered Architecture was first presented by Corporaal [9] in 1995 as an alternative for the Very Long Instruction Word (VLIW) architecture. VLIW processors represent a good platform for ASIPs, but their complexity considering the datapath increases rapidly as the application becomes complex, especially with the register file bypassing logic. Transport Triggered Architecture provides solution for this complexity. The design philosophy behind TTA is to extend the responsibility of parallel execution of processor further towards the program code. In traditional processor machine code, the program determines which operation is executed, but with TTA, the program only determines the *transports* on the bus that *triggers* the executions.

The basic principle of the architecture is presented in Figure 3.1. It consists of *functional units* (FU) connected to each other through a network of buses forming an *interconnect* (IC). The FUs can in principle be any kind of logical units, but the interface towards the IC is the same: each FU is associated with one *triggering* port, indicated with the cross boxes in Figure 3.1, one *operand* port and one *result* port. Typical TTA processor contains at least arithmetic logical unit (ALU), register file (RF) and load-store-unit (LSU) for the normal central processing unit (CPU) operation. The instruction fetch and decode is done by *global control unit* (GCU). The timings of the individual FUs can vary and are not dependent on each other. When data is written to FU's trigger port, it launches the execution inside the FU. When the trigger arrives, the FU assumes the operand port data to be present too. After the fixed time the specific operation takes, the FU provides result on the corresponding port.

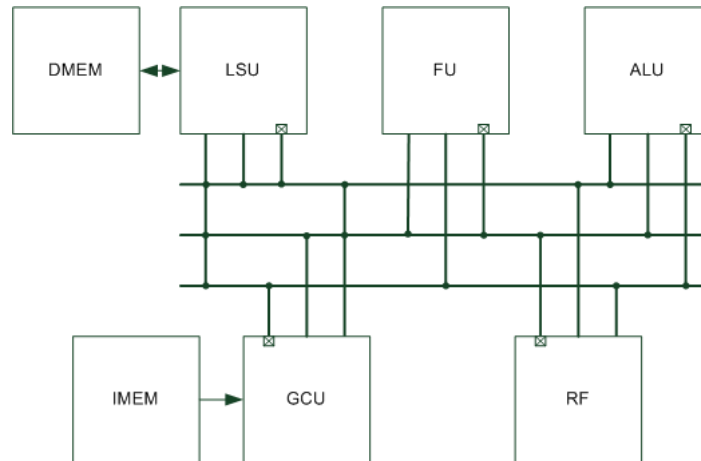

Figure 3.1. Example architecture of TTA processor. Functional units are connected together with 3 buses.

With TTA, the program code is responsible for the correct timing between the data FU operations. Depending on the IC, multiple transports are possible to execute in a single clock cycle. In the traditional assembly code of a processor the machine command determines the operation, as shown with the *add* command below.

```
add r3, r1, r2 //Add r1 and r2, and store the result in r3
```

With the command the source and target registers *r1* and *r2* are provided and the processor stores the result in the destination register *r3*. With TTA, the program determines only the data transfers. The TTA format for the same *add* command is shown below.

```
r1          -> ALU.operand //r1 contents to ALU operand port
r2          -> ALU.trigger //r2 contents to ALU trigger port
ALU.result -> r3          //Result to r3
```

The amount of multiple data transfers possible depends on the number of buses in the IC. With the example architecture in Figure 3.1 a total of three transfers are possible to execute in a single clock cycle. The possible transfers between two FUs are determined by the bus connections. This is why the TTA is good choice for ASIPs: the processor can be configured and optimized for a specific functionality by determining the optimum amount of buses and connections. The best performance is achieved by connecting all the FUs together, but this makes the IC relatively complex.

The instruction width of the processor is determined by the IC. One command has to contain information of all the transfers. For the three bus configuration, three *move slots* are included inside the command. These slots specify the destination and source IDs of the sockets on the bus network. There is also a *guard bit* involved with every slot that is used for conditional statements. The instruction contains also space for immediate delivering. Therefore, with very complex IC the width of the instruction expands as well.

As the IC becomes complex, the interrupt handling gets difficult. In worst case scenario, the whole processor state has to be saved somewhere for resuming the operation after the interrupt has been handled. This applies to all dynamic situations in TTA. Therefore, TTA is not very convenient for acting a general purpose processors.

The poor dynamic situation handling can be, however, compensated with external hosting. TTA processors are often implemented with a *global lock* that can be used for stalling the whole processor. The host locks the TTA processor whenever it detects a possible hazard condition and released it when the operation can be continued. From the TTA processor's perspective, the operation is static and no preparations for the dynamic situations are needed on TTA side.

3.2 Nokia Co-Processor

The Nokia Co-Processor is a configurable Harvard architecture [10] reduced instruction set computer (RISC) processor. The generalized high level architecture is shown in Figure 3.2. COP has separate instruction and data memories. COP has two Advanced Microcontroller Bus Architecture (AMBA) interfaces [11], one for configuration and one for accessing the system interconnect. For interrupt based communication COP has the *Exception*, *Done* and *Attn* ports. The Exception port is asserted when any kind of fault occurs inside COP. The Done port assumes values according to the internal thread state of COP and the *Attn* port can be used for waking up threads in an external interrupt.

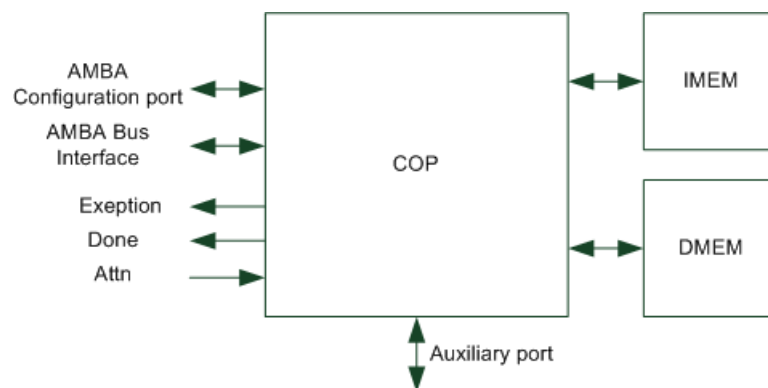

Figure 3.2. Co-Processor, high level architecture.

COP has one interesting extra feature, the *Auxiliary port* (AUX) with the relevant signals shown in Figure 3.3. This port can be considered as an extension of ALU. There are maximum of three data slots the size of the machine word of COP related to the Auxiliary operations. These can be considered the *source*, *target* and *destination* registers of normal ALU operation. Every operation is initiated with a tag and operation code and a result with the same tag is expected to be delivered at some point.

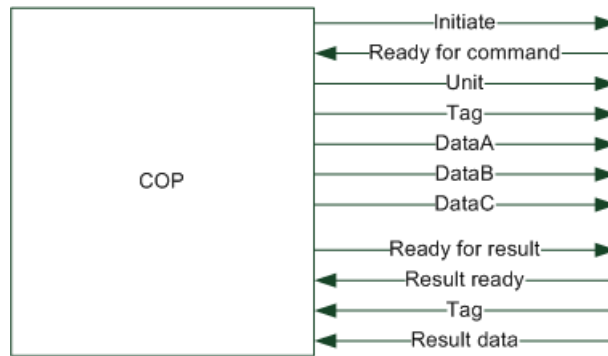

Figure 3.3. Auxiliary port relevant signals.

The timing of one Auxiliary operation is shown in Figure 3.4. COP initiates the operation with initiating signal and delivers the data with the same clock edge. The AUX unit has a ready for command signal which it can use for stalling the operation. If the unit de-asserts this signal, COP keeps on trying to initiate with the same data until the unit again informs it is ready for command. The AUX unit provides the result data with the result ready signal which is held high until COP acknowledges it. There is also information of the operation to be executed and the index of the AUX unit the operation is targeted involved with the initiation. The time between the initiate and the result assertions is not the constant 3 cycles shown in Figure 3.4, but can vary with different operations.

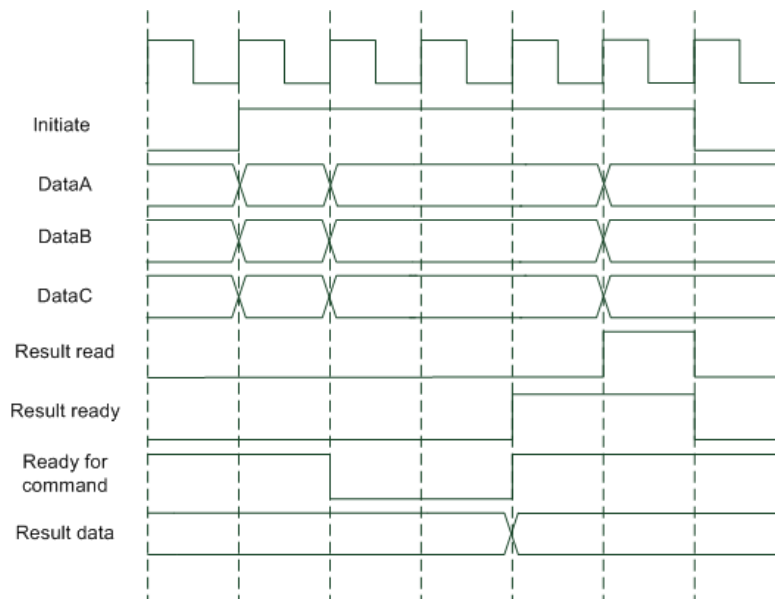

Figure 3.4. Auxiliary operation timing.

Having the AMBA configuration port, COP is well suited as a co-operation control unit since it can be easily hosted and configured for different operations. COP is especially capable with memory transactions having the AMBA bus interface. The AMBA protocols support bus widths up to 1024 and data can be moved as bursts instead of individual read and write operations [12].

4. ARCHITECTURAL ALTERNATIVES

In VLSI circuits, there are typically several memory storages containing input and output data consumed and produced by the intellectual property (IP) blocks inside the design. Data is moved between the memories and the IP blocks through buses and interconnects. This requires usually some direct memory access (DMA) units between the functional blocks and the system memory or some other control logic with system memory interface.

With the COP-TTA architecture, all the control is abstracted outside the TTA processor and the DMA responsibility is left for COP with no need for extra DMA accelerator integrated to the TTA processor. There are several ways this kind of architecture can be constructed regarding the DMA transfers and other control, and in this chapter, three different architectures are proposed for implementation and performance for each is estimated.

4.1 Single COP System: DMA Control over the System Interconnect

With the simplest architecture, one COP unit acts only as a DMA controller as shown in Figure 4.1. The main system memory, COP and the TTA processor are all connected via the system interconnect, through which all data traffic takes place.

With performing the DMA transfers, a separate *slave module* is needed between the TTA processor and the interconnect for performing the AMBA protocol conversion suitable for accessing the TTA. The slave module can be considered as an abstraction of the possible ways to connect the TTA processor to the interconnect and one solution is presented in Figure 4.2. The slave module contains all the needed control, interfaces, buffering and storage for the input and output data of TTA. Within this context, the storage is considered as Random Access Memory (RAM), to which the TTA processor has interfaces from its load-store unit LSU. The RAM is the storage from which the TTA processor fetches its input data and to where it stores the results of its operation results.

For performance estimation, let $T_{Operation}$ indicate the execution time of a specific operation in units of time, *ut*. One unit of time, 1 *ut*, corresponds to the time period of one clock cycle, assuming that the whole design works under one clock domain.

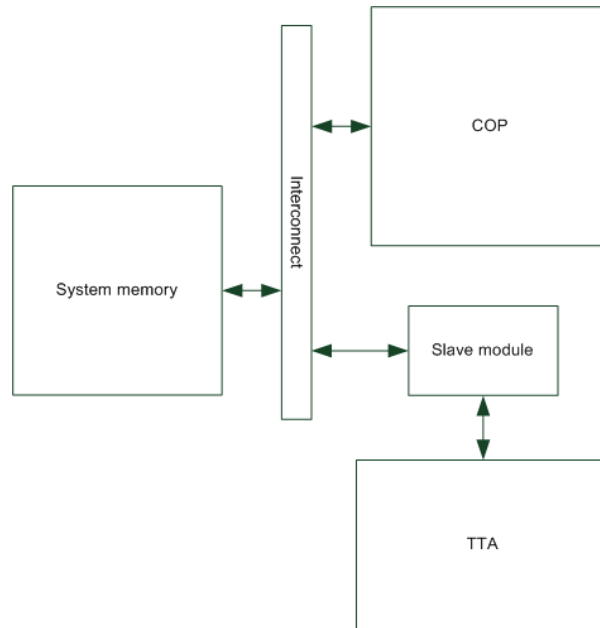

Figure 4.1. Proposed architecture for COP DMA control only, top level.

The timing of the RAM is illustrated in Figure 4.3 and is considered to be the same throughout the analysis of this chapter. The timing for the RAM accessing from the slave module's memory control point of view is stated as

$$T_{WriteRAM} = 1 \text{ ut} ; \quad (4.1)$$

$$T_{ReadRAM} = 1 \text{ ut} (+address). \quad (4.2)$$

Writing can be done in single clock cycle from the writer's point of view since the data and address are delivered at the same time. With reading there is one extra *address* cycle for the first read, but after that the throughput can be considered 1 data item in a clock cycle since the next read address is given at same time the data of the previous one is being written.

The system memory is implemented as some type of RAM as well, but the access is abstracted to the AMBA bus level. The transactions are done with the type of handshaking signaling shown in Figure 4.4. The *source* block asserts *VALID* signal when the data it is providing is ready and valid. The *destination* block asserts *READY* signal when it is ready for accepting data. When these two signals are high at the rising edge of the bus clock signal *ACLK*, the information exchange is done. The destination de-asserts the *READY* signal when it has captured the data and the information no longer need to be kept valid on the bus.

All data transactions on the bus involves separate *address* and *data phases*. The AMBA interface signaling is divided into address and data channels for both write and read operations. Each channel contains separate handshaking signals, so for every transaction there is different address and data transfer handshakes.

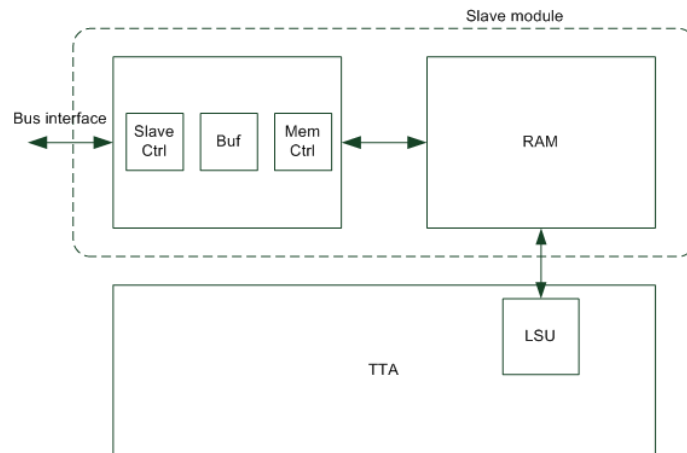

Figure 4.2. Slave module.

Since the AMBA protocols support bursts as mentioned in Chapter 3, one address phase can be followed by multiple data exchanges. Therefore, for single burst operation only one address handshaking has to be issued for large amount of data. With the data phase there is handshaking still done with every data element transferred. An example of the handshaking signaling timing over the interconnect is shown in Figure 4.5. There can be several blocks accessing the same system memory over the interconnect, so for example with the address phase the exact moment when the system memory grants access by issuing the *READY* signal is unknown. This uncertainty related to the address phase is referred here as $T_{SysMemAddress}$, representing the average time the AMBA address phase takes in system memory accessing in addition to the 1 cycle minimum handshaking. There is also a delay with every data phase information exchange called $T_{SysMemData}$, which represent the average time a data exchange takes.

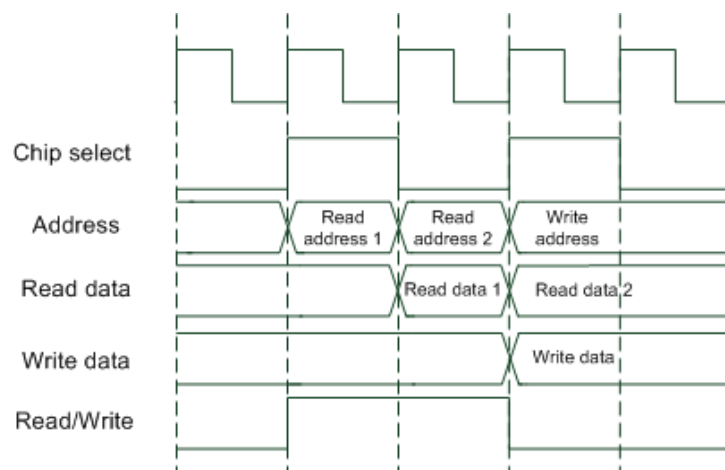

Figure 4.3. RAM timing.

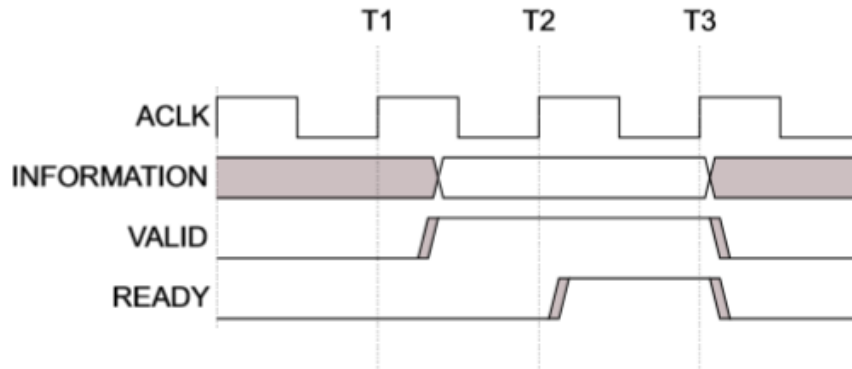

Figure 4.4. AMBA handshaking [12].

For performance estimations, let the system interconnect word size be 128 bits, which is one of AMBA bus widths. This is also one of the generic word sizes COP can be configured for. Let also the input and output samples the TTA processor operates with be 32-bit wide, as well as the width of the RAM. With 128-bit word, a total of four 32-bit samples can be transferred on the bus at once. If considering bursts the length of 16, a total of 64 samples can be transferred as a single transaction with one address phase. By including one address phase with in every burst and the delay $T_{SysMemData}$ with every data information exchange, the time for the system memory accessing in both writing and reading directions can be stated as

$$T_{SysMemBurst16} = T_{SysMemAddress} + 16T_{SysMemData}. \quad (4.3)$$

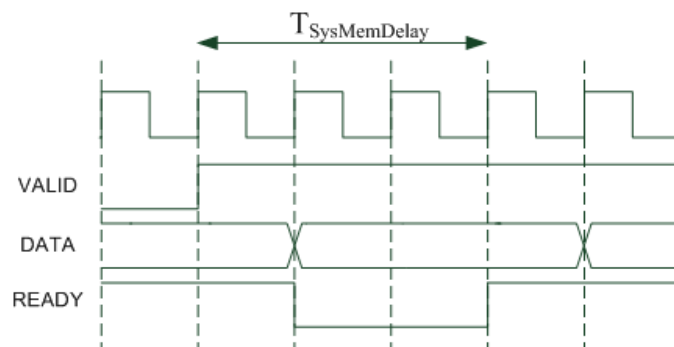

Figure 4.5. AMBA burst data phase timing example.

The slave module access timing is could be considered the same as in (4.3), but if the slave module is however fully optimized for COP data writing and reading, the delays related to the address and data phases can be considered to be constant. The buffering shown in the block diagram of Figure 4.2 ensures that the module can accept data with higher rate than it is able to write to the RAM. Therefore, one 64 sample write burst towards the slave module can be executed with 1 clock cycle address phase and 1 clock cycle data exchanges and the time is

$$T_{COPWriteSlave64} = T_{SlaveAddressPhase} + 16T_{SlaveDataPhase} = 1ut + 16ut = 17ut, \quad (4.4)$$

where the terms $T_{SlaveAddressPhase}$ and $T_{SlaveDataPhase}$ correspond to the address and data phase delays. The data phase timing of the writing of the slave module is illustrated in Figure 4.6. With the buffering implemented inside the module it can accept 4 samples on every clock cycle although the RAM is accessed slower. The RAM writing starts immediately after the module has received the first samples. $T_{COPWriteSlave64}$ is the time that COP experiences when writing towards the slave module. As seen from Figure 4.6, the RAM is written much slower. The time COP experiences for the samples to be written in the RAM is

$$T_{COPWriteSlaveRAM64} = T_{SlaveAddressPhase} + 1ut + 64T_{WriteRAM} = 66ut, \quad (4.5)$$

where the one extra clock cycle represents the capturing of the first RAM write address.

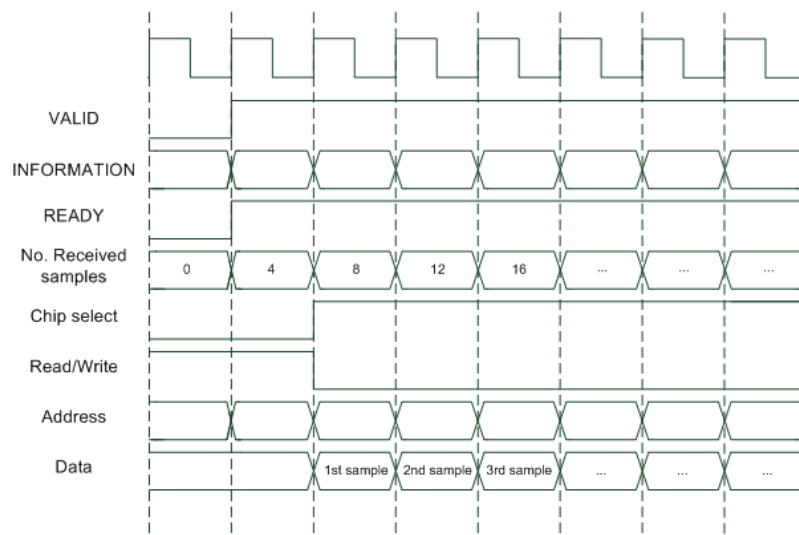

Figure 4.6. Slave write operation data phase timing.

In the opposite direction, the address phase of the slave module reading can be considered constant, as was with the writing. But the RAM reading forms a bottleneck in the read flow because only one sample can be read in a clock cycle from the RAM after the first RAM address has been written. The timing of the slave module reading data phase is shown in Figure 4.7. Reading 4 samples from the RAM takes 4 clock cycles as indicated by $T_{ReadRAM4}$ in the figure. There are still two extra cycles in the beginning of the burst for capturing the read address and writing it for the RAM. The timing for the 64 result samples read can therefore be stated as

$$T_{COPReadSlave64} = T_{SlaveAddressPhase} + 2ut + 64T_{ReadRAM} = 67ut, \quad (4.6)$$

where the term $T_{ReadRAM}$ is the RAM reading time stated in (4.2).

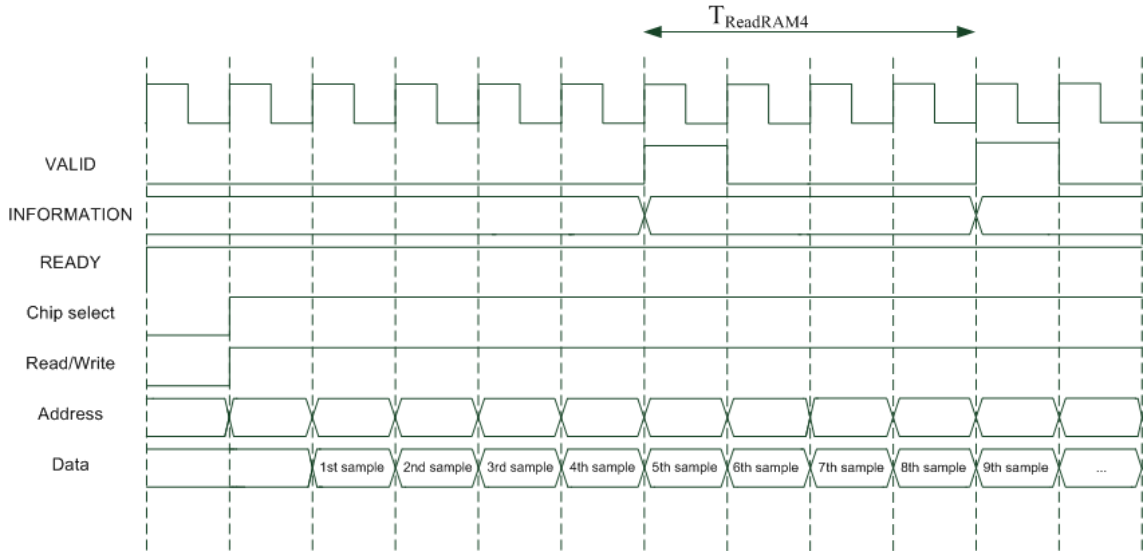

Figure 4.7. Slave read operation data phase timing.

The timing can be expanded to $64N$ samples as well. For calculating the full operation time of $64N$ samples including the TTA processor operation time, T_{TTA} , (4.5) and (4.6) for $64N$ samples can be stated as

$$T_{COPWriteSlaveRAM64N} = 66Nut \quad (4.7)$$

and

$$T_{COPReadSlave64N} = 67Nut. \quad (4.8)$$

The full $64N$ size operation time can then be written as

$$\begin{aligned} & T_{64NSamples,SlaveArch} \\ &= NT_{SysMemBurst16} + T_{COPWriteRAM64N} + T_{TTA} + T_{COPReadSlave64N} + NT_{SysMemBurst16} \\ & \quad 2NT_{SysMemAddress} + 32NT_{SysMemData} + 133Nut + T_{TTA}. \end{aligned} \quad (4.9)$$

One more interesting measure is the part of the overall operation time $T_{64NSamples,SlaveArch}$ is the part that COP is occupied with the data transfers. This time can be stated with (4.4) expanded for $64N$ samples as

$$\begin{aligned} & T_{COP64N,SlaveArch} \\ &= 2NT_{SysMemBurst16} + NT_{COPWriteSlave64N} + T_{COPReadSlave64N} \\ &= 2NT_{SysMemAddress} + 32NT_{SysMemData} + 84Nut. \end{aligned} \quad (4.10)$$

4.2 Single COP System: DMA Control over the Auxiliary Interface

With the second proposed architecture, the data traffic between COP and the TTA processor is arranged through the Auxiliary interface of COP, described in Chapter 3. The top level block diagram of the architecture is shown in Figure 4.8. This architecture requires separate *Auxiliary unit* that converts the data on the AUX port suitable for the TTA processor.

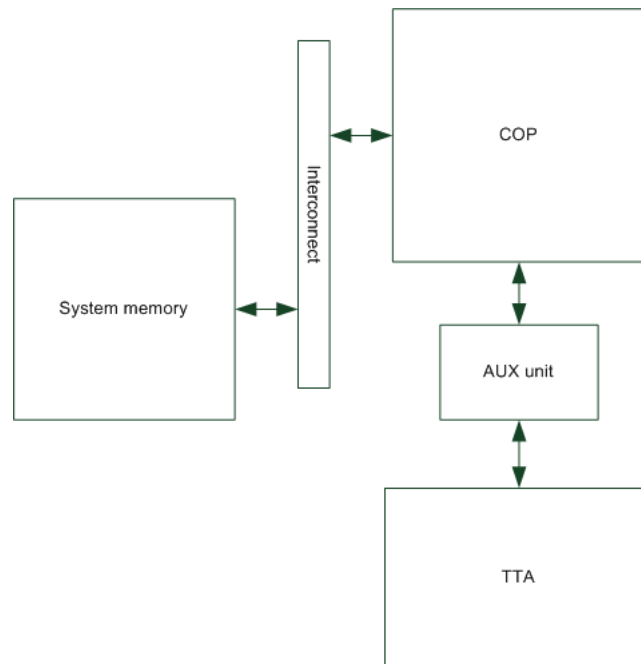

Figure 4.8. One COP and AUX interface, top level.

The block diagram of the needed AUX unit is shown in Figure 4.9 with the COP and TTA interfaces. The block contains all the needed control towards the AUX interface, buffering and data storing, as was with the slave module in the previous section. The storage is modeled as RAM also with this architecture.

The data rate at which COP can operate the system memory over the AMBA bus is the same as was with the previous architecture. The timings with the 128-bit COP architecture and bus data width for 64 sample read and write are the ones described in (4.3).

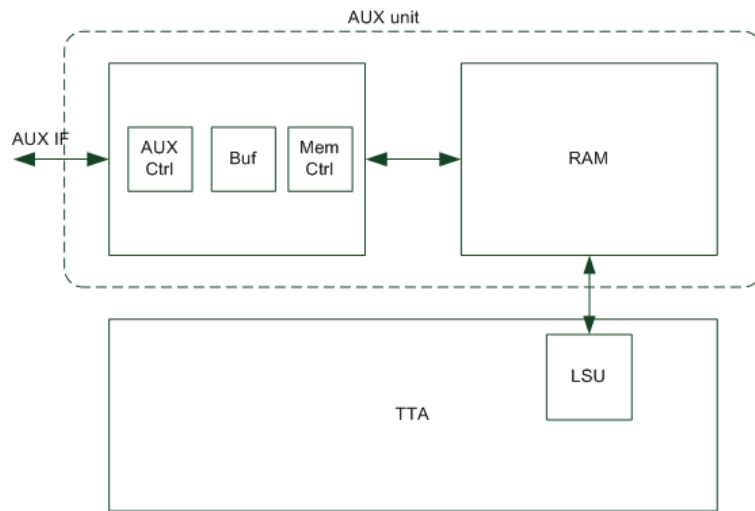

Figure 4.9. Auxiliary unit.

As described in Chapter 3, the Auxiliary port of COP can deliver maximum of 3 data items the size of the processor's machine word in 1 clock cycle. Each command, with which the 3 data items are delivered, expect a result as was indicated already in Chapter 3. To get the best throughput possible the commands should be pipelined as shown in Figure 4.10. The result of the previous operation initiated is sent at the same time the current operation is being read.

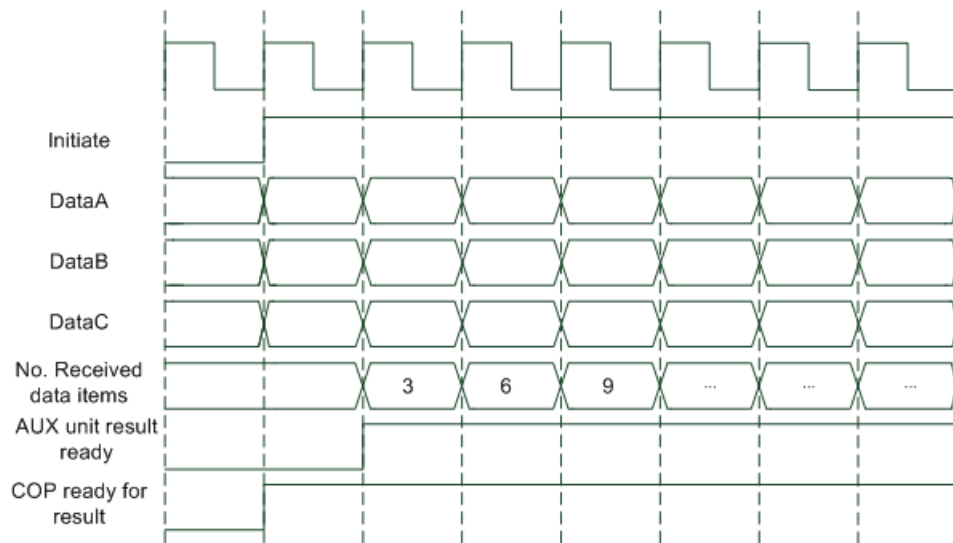

Figure 4.10. AUX port write timing.

In the opposite direction, 1 data item can be read in a clock cycle as a result for one initiated operation. If considering only a single command, it would take 2 cycles to read 1 item. The reading can be pipelined the same way as the writing as shown in Figure 4.11 to get the 1 result item per clock cycle rate.

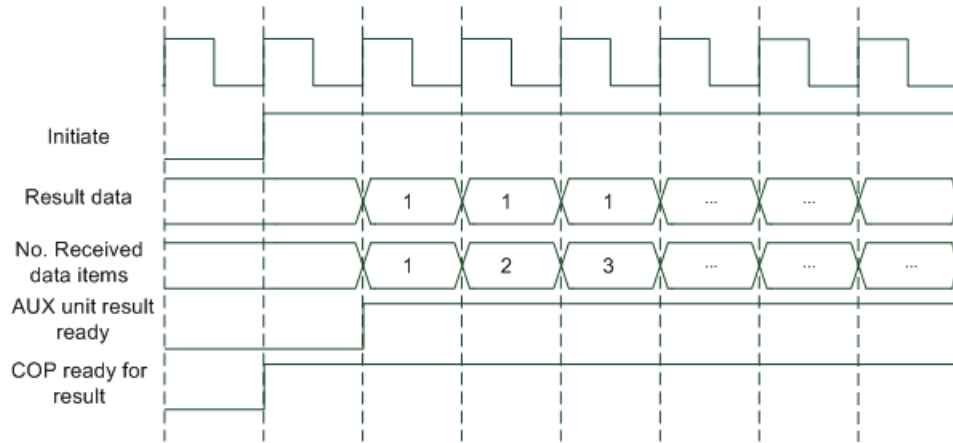

Figure 4.11. AUX port read timing.

With 128-bit architecture, a total of 12 samples can be delivered in a single clock cycle. On the opposite direction, 4 samples can be delivered for COP also in a single cycle, if the operations are pipelined. Considering the same 64 sample operation as in the previous section, a total of 5 writes the size of 12 samples and 1 write the size of 4 samples are needed for delivering 64 samples. From COP's perspective the time for this operation is

$$T_{COPWriteAUX64} = 5 * 1ut + 1ut = 6ut. \quad (4.11)$$

As was with the pervious architecture's slave module writing time $T_{COPWriteSlave64}$, this is also the time that COP experiences with writing the Auxiliary unit without the RAM access time being concerned. If the Auxiliary unit is constructed in the same manner as was the slave module, as shown in Figure 4.9, COP does not have to wait before initiating a new AUX write as the buffer of the AUX unit ensures the fluent data flow and the pipelining can be done.

The AUX unit can start writing the RAM when the first 3 data items are received and 1 clock cycle capturing delay. Therefore, the time for COP to write the 64 samples all the way to the RAM is

$$T_{COPWriteAUXRAM64} = 1ut + 64T_{WriteRAM} = 65ut. \quad (4.12)$$

The timing of the 64 results reading can be analyzed in the same manner as the reading with the previous architecture. The RAM reading forms a bottleneck also with this architecture, and if the RAM reading is started with the first initiated command, the pipelining cannot be done with the same rate as in Figure 4.11 but with similar manner as was in presented in the previous section. The AUX port read timing with the RAM included is presented in Figure 4.12. There are the same 2 cycle delay before the first sample is read as was in Figure 4.7. For every 4 samples there is a 4-cycle delay. There are also 2 extra cycles due to the data capturing and RAM write addressing. Therefore, the time is

$$T_{COPReadAUX64} = 2ut + 64T_{ReadRAM} = 66ut. \quad (4.13)$$

The AUX accessing times in (4.12) and (4.13) can be expanded for the same $64N$ size operation as with the previous architecture. Since there are no separate access phases, no extra cycles for the data capturing are needed after the first one in writing direction, so the $64N$ input samples timing over the AUX writing all the way to the RAM is

$$T_{COPWriteAUXRAM64N} = 1ut + 64NT_{WriteRAM} = 1ut + 64Nt. \quad (4.14)$$

In the reading direction, the two extra cycles are present only with the first read and after that the RAM accessing speed limits the data rate, so the time can be stated as

$$T_{COPReadAUX64N} = 2ut + 64NT_{ReadRAM} = 2ut + 64Nt. \quad (4.15)$$

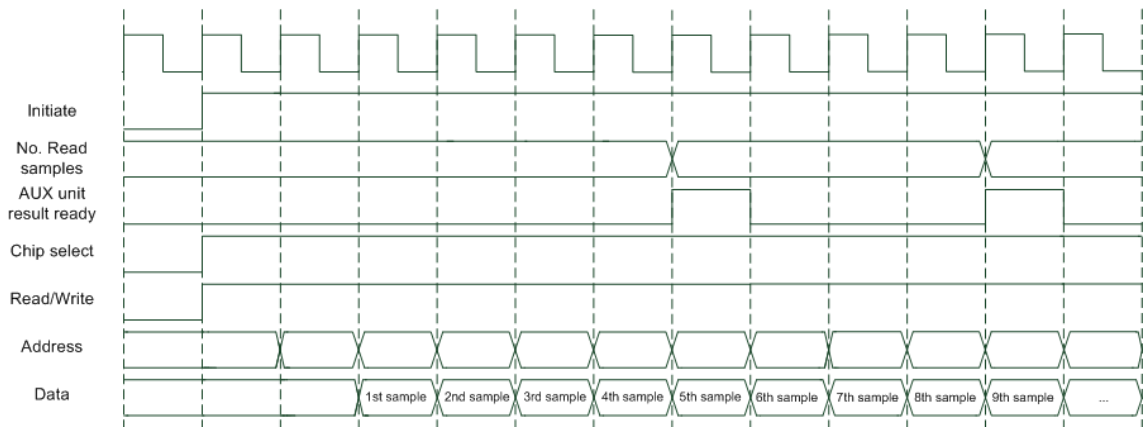

Figure 4.12. AUX port read with RAM timing.

The full $64N$ size operation can be stated as

$$\begin{aligned}
& T_{64NSamples,AUXArch} = \\
& NT_{SysMemBurst16} + T_{COPWriteAUXRAM64N} + T_{TTA} + T_{COPReadAUX64N} + NT_{SysMemBurst16} \\
& = 2NT_{SysMemAddress} + 32NT_{SysMemData} + 1ut + 64Nt + 2ut + 64Nt + T_{TTA} \\
& = 2NT_{SysMemAddress} + 32NT_{SysMemData} + 3ut + 128Nt + T_{TTA}. \quad (4.16)
\end{aligned}$$

If the time COP is occupied with the AUX writing as in (4.11) is expanded for the $64N$ samples as well, the time COP occupied time of the full operation can be stated as

$$\begin{aligned}
& T_{COP64N,AUXArch} \\
& = 2NT_{SysMemBurst16} + NT_{COPWriteAUX64N} + T_{COPReadAUX64N} \\
& = 2NT_{SysMemAddress} + 32NT_{SysMemData} + 6Nt + 2ut + 64Nt \\
& = 2NT_{SysMemAddress} + 32NT_{SysMemData} + 2ut + 70Nt. \quad (4.17)
\end{aligned}$$

4.3 Dual COP System

One option for the design is to use two COP units instead of one. With this approach, the first COP is configured as the inputs provider for the TTA processor and the second for the output reading to the system memory. With this architecture, the TTA processor interface can be implemented with either of the previously presented ways, as a slave device accessible over the interconnect or as a CPU extension of the AUX interface. The timing values calculated in the previous sections are valid for the two COP architecture also. The top level block diagram of two COP architecture with the Auxiliary port as the interface towards the TTA processor is presented in Figure 4.13. For this approach the AUX unit operation has to be split in two.

The two COP approach provides better performance for the design. The total throughput stays the same as with the single COP architecture, but the time each COP is occupied reduced dramatically. The COPs processing times over one $64N$ samples operation are

$$T_{COPCommand} = NT_{SysMemAddress} + 16NT_{SysMemData} + 6Nut \quad (4.18)$$

and

$$T_{COPResult} = 2ut + 64Nut + NT_{SysMemAddress} + 16NT_{SysMemData}. \quad (4.19)$$

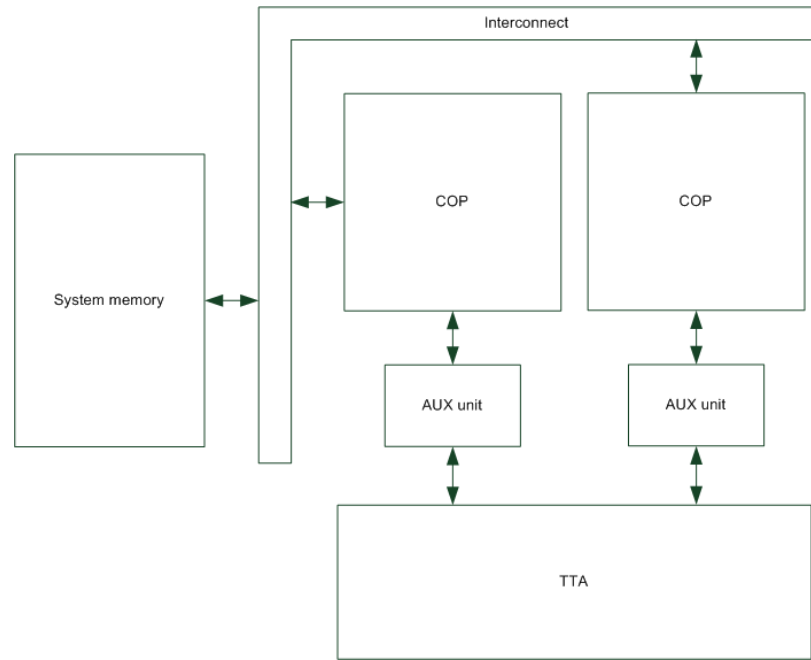

Figure 4.13. Two COP and AUX units, top level.

4.4 Performance Comparison

With the AMBA bus timings being the same for both of the proposed single COP unit architectures, the $64N$ sample operation timings in (4.9) and (4.16) differ by

$$T_{DifferenceFullOperation} = 133Nut - 3ut - 128Nut = 5Nut - 3ut. \quad (4.20)$$

and it can be stated that the Auxiliary unit architecture is faster due to its ability for larger data delivering at a time.

One more interesting comparison between the two architectures is the COP operation time presented in (4.10) and (4.17). The difference between the times is

$$T_{COPDifference} = 84Nut - 2ut - 70Nut = 14Nut - 2ut. \quad (4.21)$$

The AUX unit architecture is clearly better from this perspective as well. The reason why the COP occupied part of the whole operation time is interesting is that as a general RISC processor COP can perform other functionality as well while not transferring data, rather than acting only as a DMA controller. This functionality can be related to the task being processed on the TTA processor or something else. This time is referred as *slack time* and it can be stated as

$$T_{COPSlack,SlaveArch} = T_{64NSamples,SlaveArch} - T_{COP64N,SlaveArch} = 49Nut + T_{TTA} \quad (4.22)$$

and

$$T_{COPSlack,AUXArch} = T_{64NSamples,AUXArch} - T_{COP64N,AUXArch} = 1ut + 58Nut + T_{TTA}. \quad (4.23)$$

The operation time of the TTA processor is application specific and can be left out when comparing the slacks. Different slack times are listed in Table 4.1 with different values of N with the TTA processing time left out. It can be seen that with 4096-size operation the difference with the slack is in the scale of hundreds of clock cycles.

Table 4.1. 64N-size operation COP slack times without TTA processing delay.

N	Operation size (number of samples)	Slack, Slave module architecture (ut)	Slack, AUX unit architecture (ut)
1	64	49	59
2	128	98	117
4	256	196	233
8	512	392	465
16	1024	784	929
32	2048	1568	1857
64	4096	3136	3713

5. IMPLEMENTATION

Of the three proposed architectures, the one described in section 4.2 was selected for implementation. In addition to DMA control it was in high interest to demonstrate the usage of the Auxiliary port of COP in practice. The single COP architecture was chosen over the two COP design for simplicity reasons and to demonstrate the power and usefulness of COP as an independent control unit.

The implementation had three steps: designing and building the missing hardware between the Auxiliary unit and the TTA processor, integration of all of the building blocks together as one design and developing software for COP to run the use case application. All the functional hardware in the design was implemented with Very High Speed Integrated Circuit (VHSIC) hardware description language (VHDL).

5.1 Top Level Design

Detailed top level architecture of the design is shown in Figure 5.1. All the used blocks and memories are shown on a block level abstraction.

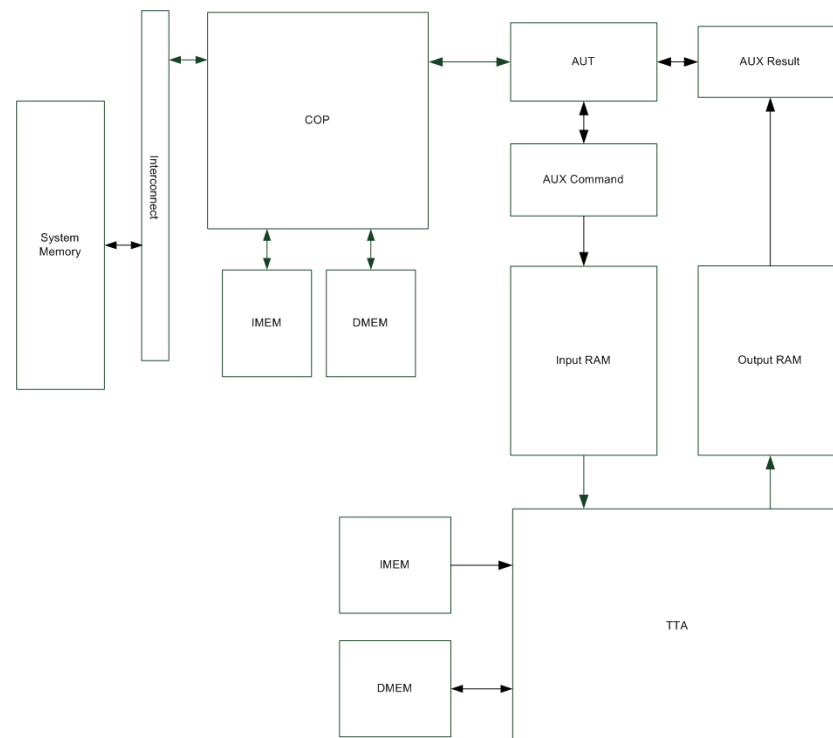

Figure 5.1. Single COP design, top level.

The *Auxiliary Unit* was split into two independent functional blocks, the *Command* and the *Result* block. The internal structure of these blocks is described in detail in section

5.3. Arbitration between these blocks is done by ready-made *Auxiliary Unit Transceiver* block (AUT).

5.2 COP Configuration

For the architecture selected for implementation, COP was configured for 128-bit machine word size. With this word size, a total of 12 32-bit samples can be delivered through the Auxiliary unit towards the TTA processor and 4 32-bit samples read back with one Auxiliary command.

COP was configured for 4 separate threads. The register space of COP was split between the threads so that each holds 32 general purpose registers. The Auxiliary port was configured to support 2 units. The arbitration between the AUX units was done with the AUT which can be used for chaining the Auxiliary units as illustrated in Figure 5.2. The AUT unit reads the *Unit* signal when COP initiates new command and based on the value of the signal the AUT unit forwards the *Initiate* signal to the right AUX unit.

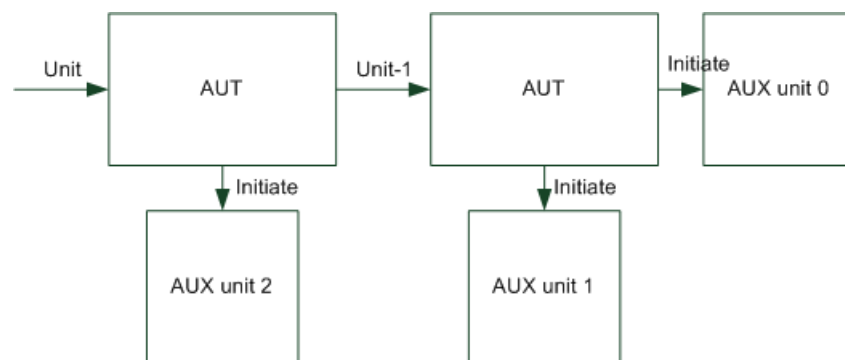

Figure 5.2. AUX units chaining with AUT units.

5.3 Auxiliary Units

The basis for the AUX units was to design a generic interface between COP and TTA processor. With this in mind it was reasonable choice to split the one unit into two. For example in the two COP design both COPs would be wrapped up with just one of the AUX units. The two blocks are referred as *Command* and *Result block*. This section describes the main structure and operation of the blocks.

5.3.1 Interfaces

There are differences with the memory and the TTA control interfaces between the two AUX units, but towards COP both interfaces are similar, as illustrated in Figures 5.3 and 5.4. Both blocks work under single clock and reset domain.

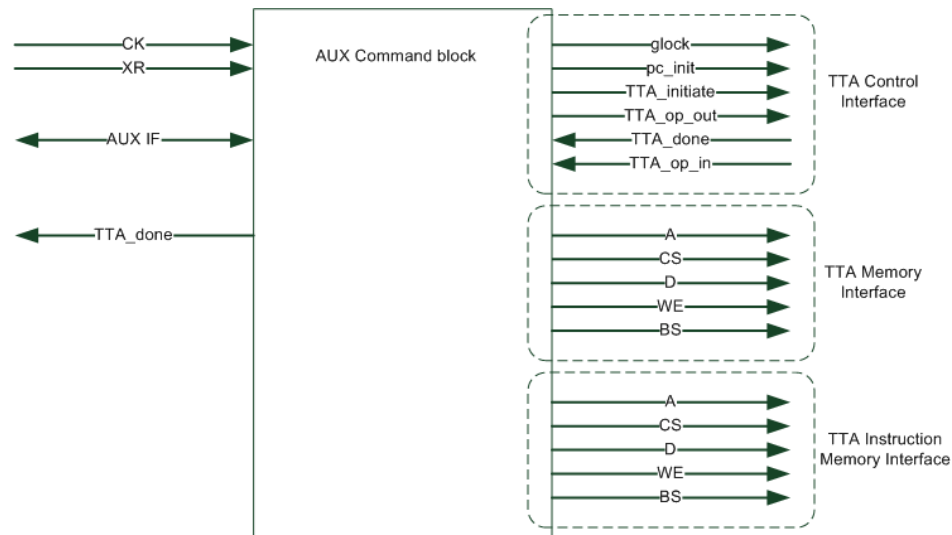

Figure 5.3. Command block interfaces.

Both the blocks have interface towards TTA. The Command block uses the interface to initiate TTA processor operation with the *TTA_initiate* and *TTA_op_out* signals. The *TTA_done* and *TTA_op_in* signals in the interface are there for the internal bookkeeping of the initiated and ready operations on the TTA processor. The *TTA_done* signal is also forwarded to the *Attn* port of COP. More of the usage of the *Attn* port with this implementation is described in section 5.6.

The opcode was designed to carry the base address of the input data towards TTA and the base address of the results towards the Result block. For simplicity reason it was used with this design only to carry the opcode for the operation initiated i.e. the index of the memory segment where the data is located.

The only signal used in the TTA control interface of the Result block is *TTA_op_in* that delivers opcode for the base address. Rest of the interface is used mainly for bookkeeping information of the initiated and ready operations on the TTA processor, as was with the Command block. The Result block does not issue any result reads without the corresponding commands coming first from COP.

The TTA memory interfaces are similar in both blocks, except for the direction of the memory access. The RAM signals are the basic address *A*, chip select *CS*, data *D*, write enable *WE* and bit select *BS*. The Command block is used only for writing input data and the Result block for reading the results, so only the write data signal *D* needed to implement in the Command block and the read data signal *Q* in the Result block.

There is also a memory interface for the TTA instruction memory writing in the Command block. This was implemented because no external configuration port was placed on the TTA processor for accessing the memory.

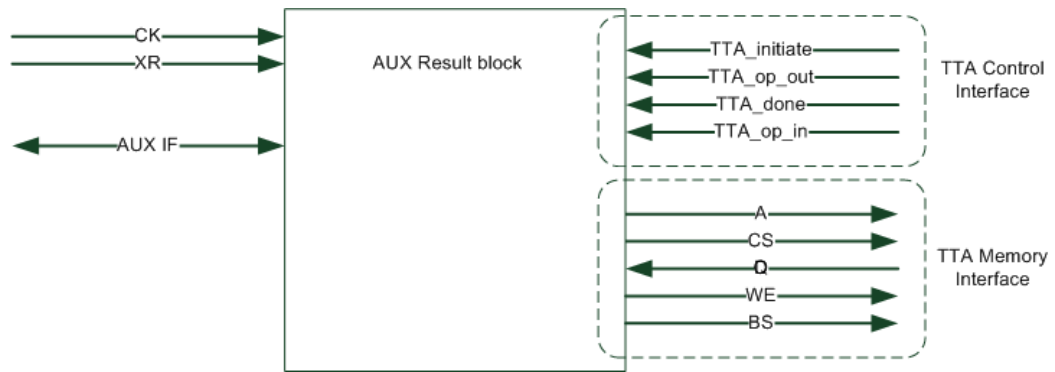

Figure 5.4. Result block interfaces.

5.3.2 Transaction Protocol

To transfer the data between COP and TTA processor as efficiently as possible, a simple protocol was constructed for the Auxiliary unit data transfers. For example in the writing direction, the Command block needs addresses for the input samples it receives and the information when it has received all the samples and the TTA processor can be released for operation. Data is usually transferred in large chunks at a time, so it is more practical to handle the data transfers as a *transactions* initiated with base address and number of read/write operation rather than include this information in every Auxiliary command.

The commands implemented with the AUX blocks are listed in Tables 5.1 and 5.2 with the related description, parameters and result. The command itself is delivered with the AUX port's *Operation* signal. The parameters are transferred with the data signals *DataA*, *DataB* and *DataC*. The parameters can be data or information of some kind. COP hardware expect a result for every initiated command, so the command block has to provide one. There is, however, not any relevant data given, except with the *Init* command there is message for errors. The rest of the results do not have to contain any data and no valid information is sent as a result with the Command block. This is why the results in the Tables 5.1 and 5.2 are set as *Discarded* except for the *Init* command.

Table 5.1. Command block commands.

Command	Description	Parameters	Result
Init	Initiate new write transaction	Base address, Number of samples to be written	Error message if no room for samples
APartial	Delivery of 1-3 sample	Data	Discarded
AFull	Delivery of 4 samples	Data	Discarded
ABCFull	Delivery of 12 samples	Data	Discarded
IMemWrite	Write word to TTA IMEM	Data, address	Discarded

The write transaction with Command block works as follows: transactions are initiated with the *Init* command. Two parameters are delivered for Command block with the command with the data signals *DataA* and *DataB*: the base address for TTA input memory writing and the number of samples to be written. The Command block captures these values into variables *NumOfWrites* and *Addr*. If there is space in the TTA input memory for this amount of samples and the address is in the allowed range, the Command block sends all zeros as result for COP. This acts as response for the initiate command. If either of the parameters violates the allowed conditions, all ones is send as error message.

After the transaction initiation, the Command block can start accepting input data. It is on the Command block's responsibility to do all the buffering and memory address updating after the *Init* command so that the software on COP can perform the AUX writing fluently. If the Command block needs to stall the transaction for some reason, it de-asserts the ready for command signal and gives no results for COP before the transaction can be continued. This way COP pauses its instruction execution and waits before it continues the writing. From software point of view the data is provided with registers and received in a register and there is always the ID number of the Auxiliary unit delivered with the commands (the *Unit* parameter). Pseudo code example for the Command block writing looks as follows:

```
ldi  r1,  NumOfSamples           //The number of samples
ldi  r2,  Address
ldi  r3,  0
aux  Unit, Init,          r1, r2, r3 //Initate with the parameters
breq r3,  ERROR          //Check for errors
aux  Unit, ABCFull,      r4, r5, r6 //Registers r4-r6 contains write data
aux  Unit, ABCFull,      r7, r8, r9
aux  Unit, AFull,        r10, r11, r12 //Only r10 contains data
```

The command block has one extra command, *IMemWrite*, listed last in Table 5.1. This command is used to write to TTA instruction memory. For simplicity reasons and the fact that the instruction word length of the TTA processor is most probably not divisible with the power of two (42 bits in this implementation), the TTA instruction memory writing is not implemented as transaction. Instead, the instruction memory address and the data to be written are provided with the data signals *DataA* and *DataB*.

The Result block read transaction is initiated with the *Init* command, as was with the Command block. Similar error response is related to the read initiation as was with the Command block, which is issued if initiation is done when no result data is available on the TTA output memory. With the results *Init* operation only the number of reads is delivered for the Result block. It is on the Result block's responsibility to do the bookkeeping for the locations of the ready data in the TTA output memory. The bookkeeping is done according to the TTA interface signaling.

The number of the reads is stored in variable *NumOfReads*. After the *Init* command COP starts issuing AUX port commands and the read samples are provided as result for each command. Pseudo code example for the read transactions is listed below.

```
ldi r1, NumOfReads //Number of reads
ldi r2, 0
ldi r3, 0
aux Unit, Init, r1, r2, r3 //Initiate with the parameter
breq r3, ERROR
aux Unit, Read4, r1, r2, r3 //Read 4 command
st r3, SysMemAddr //Store the result data (the read data)
aux Unit, Read4, r1, r2, r3 //Read command
st r3, SysMemAddr //Store the result data (the read data)
```

The code execution stalls with the Auxiliary command if the Result block de-asserts the ready for command signal. The system memory store operations are therefore not executed before the previous AUX read result is given.

The Result block has one extra command, *ReadyCount*, as listed in Table 5.2. This command was implemented for the COP to be able to inquire new results. This feature was not in fact taken in use in the final implementation because the assertion for new data was done through the COP *Attn* port.

Table 5.2. *Result block commands.*

Command	Description	Parameters	Result
Init	Initiate new read transaction	Number of samples to be read	Error message if no results available
Read1	Read 1 sample	None	Result sample
Read4	Read 4 samples	None	Result samples
ReadyCount	Get the number of ready result groups	None	Count of ready result groups

For either of the blocks, no distinct stop command for the transaction was needed, because both blocks observe the *NumOfWrites* and *NumOfReads* variables and operate on the memories according to these. The transactions can, however, be stopped simply by initiating new transaction with the *Init* command.

5.3.3 Datapath

Data can be delivered for Command block and read back from Result block in various chunks of samples. The TTA input and output memories are accessed with only one sample per clock cycle, so input data slicing and result data wrapping into 128-bit form is needed.

As shown in Figure 5.5, the datapath of the Command block can be separated into four stages. The incoming data from the *Command stage* is captured on the *Capture stage*.

According to the Auxiliary command parameters, the control logic decides how many samples are sliced and inserted to buffer on the *Buffer stage*. At the *RAM stage* the data from the buffer is written to RAM if there are samples in the buffer. The control logic takes care of the buffer accessing pointers updating and the RAM writing. More about the buffer implementation is described in section 5.3.5.

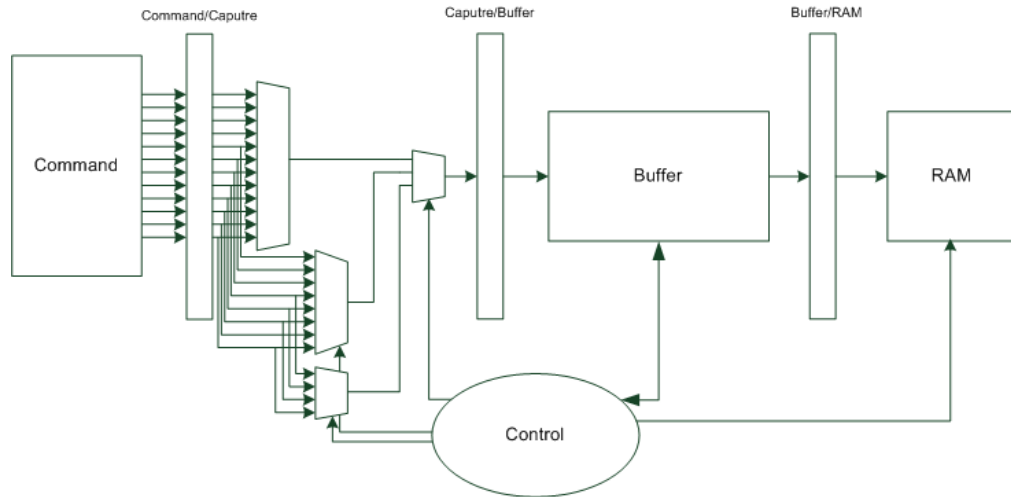

Figure 5.5. *Command block datapath.*

The datapath of the Result block, shown in Figure 5.6, is very much like reversed datapath of the Command block. However, there is no separate capture stage and the data read from RAM is inserted into the buffer immediately on the next stage after the RAM stage. The buffer itself is implemented with the same principle as the buffer inside the Command block, but the data form inside the buffer is different. The Command block's buffer holds the data in the 32-bit sample size form, but inside the Result block the samples are arranged in 128-bit AUX port result form. The control logic is responsible for inserting the data into the right 128-bit slot and into the right position within this slot. The data is delivered for COP at the result stage.

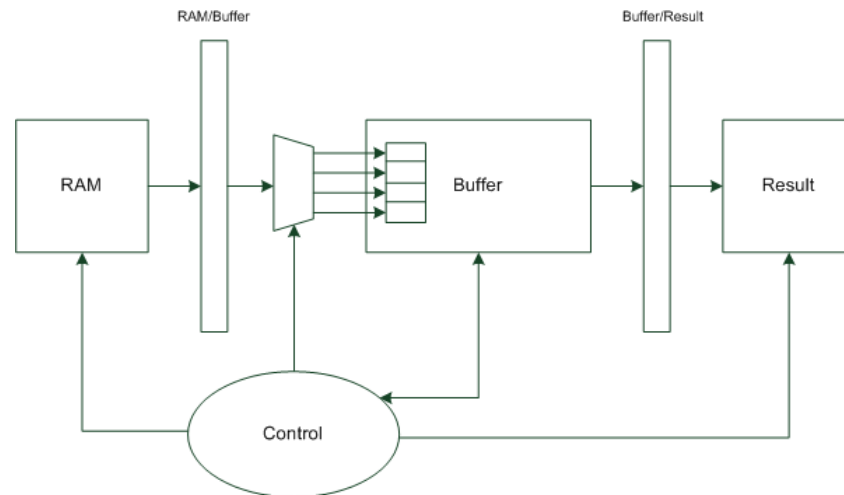

Figure 5.6. Result block datapath.

5.3.4 State Diagrams

The control over the Command block datapath was constructed with a separate processes for the command port, buffer and RAM control functionalities. These are be illustrated as state diagrams, shown in Figure 5.7.

The control over the data capturing on the AUX port is illustrated in Figure 5.7a. The process observes the *Initiate* signal and if a new command is initiated when the Command block's status is ready for command, the data along with the tag of the operation is captured. The results for the commands are given according to the state diagram in 5.7b. This process observes the same conditions as the previous one. The result state is kept if there is a new initiation and the block is ready for the command. If there is initiation with the block not being ready, or no initiation, the process performs waiting and no results are given for the initiated commands. If COP tries to initiate when the Command block is not ready, it keeps on trying the initiation with the same data and tag until the block is signaled ready and the data can be captured.

The signaling of the Command block's status of being ready for a new command is controlled by the state diagram in 5.7c. The ready for command signal is kept high if there is space in the buffer. If the buffer becomes full the signal is de-asserted until there is again space in the buffer.

The RAM writing is controlled by the state diagram in 5.7d. When the *Init* command is issued at the AUX port and accepted, the control enters the waiting state. This state is held until there is something to be written in the buffer. If the buffer empties during transaction the control enters the waiting state. When all the samples indicated by the *NumOfSamples* variable is written, the control returns to waiting for a new transaction initiation.

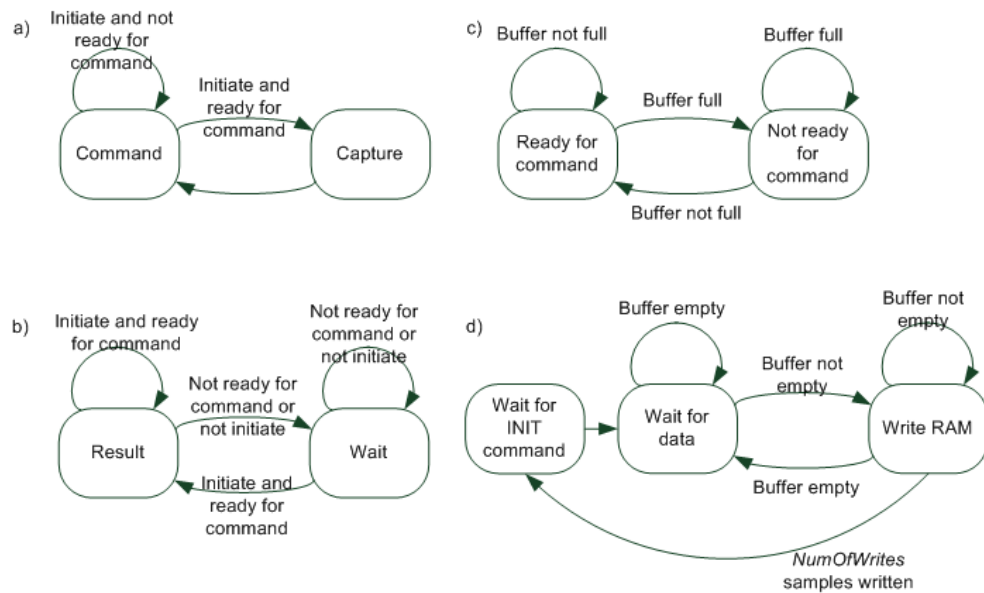

Figure 5.7. Command block state diagrams with a) capture b) ready for command c) result d) RAM control.

The Result block control state diagrams are shown in Figures 5.8 and 5.9. The RAM reading is started immediately after the initiation of a new transaction. The memory control can be viewed with three states. The first one in 5.8a observes the initiations and if there is an Auxiliary command with new transaction initiation, the control moves to the RAM addressing state. The addressing is done *NumOfReads* times starting from the base address the Result block has saved after the TTA processor has issued operation done. The data capturing control in 5.8b moves to the read RAM state with one clock cycle behind the addressing. The two processes are operating with pipelined manner. Both state diagrams will enter the waiting state if the memory accessing is externally stalled. The stalling is controlled by the state diagram in 5.8c by observing the state of the buffer. If the buffer becomes full, the RAM reading is stalled.

The results are provided for the initiated commands similar way as with the Result block. In the state diagram in 5.9a result is only provided when there is a new initiation on the AUX port and the block is ready for it. The state diagram in 5.9b shows the ready for new command control. If the buffer is empty and there is no data to provide as a result for AUX command, the block holds the ready signal down.

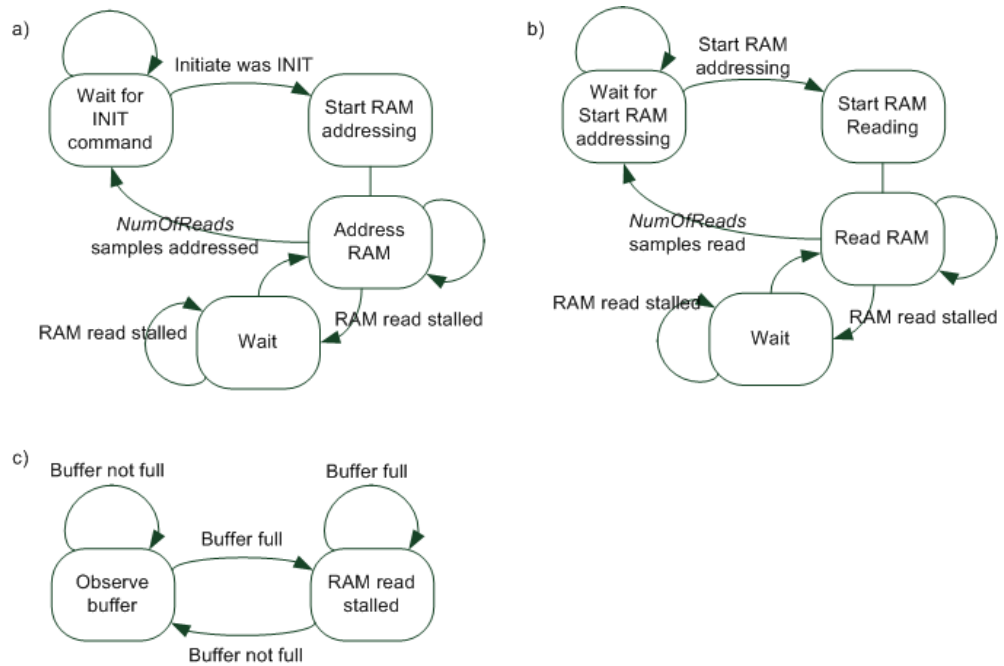

Figure 5.8. Result block RAM reading related state diagrams with a) addressing b) read data capturing c) buffer control.

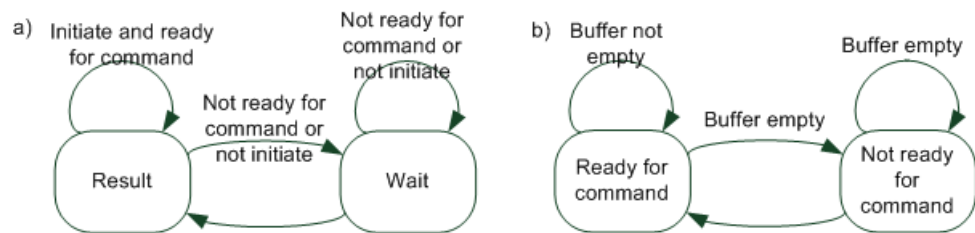

Figure 5.9. Result block state diagrams related to a) result b) ready for command control.

5.3.5 Buffers

The buffers needed in the datapaths were implemented as generic length first-in-first-out (FIFO) buffers, as shown in Figure 5.10. The number of data slots, N , corresponds the buffer depth. Free slots are shown as white and the occupied ones with the darker color.

The buffer is accessed through variables *AddPointer* and *GetPointer*. These variables are updated when the buffer is written or read. The amount of available data slots in the buffer equals to the buffer depth, denoted by N in the figure. The *BufferSpace* variable is updated with respect to the pointer variables.

Empty buffer configuration at reset is shown in 5.10a. The *AddPointer* points to the beginning of the buffer and the *GetPointer* to the last slot. When new data is written to the buffer, the *AddPointer* is increased by the amount of samples written and the *GetPointer* is moved to point to the first value. The buffer state after three samples written is shown in 5.10b.

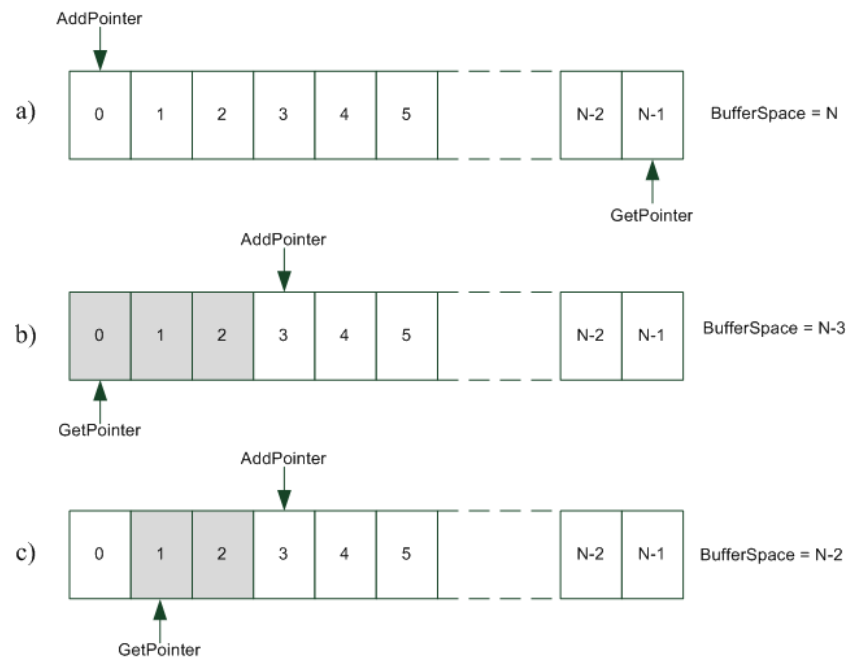

Figure 5.10. Buffer operation with a) buffer empty b) buffer filled with 3 samples c) buffer filled with 2 samples.

When data is read from the buffer, the *GetPointer* is increased by the amount of the samples read. 5.10c shows the buffer state after the 5.10b state when one sample has been read.

The buffers accessing is constructed in a way that more than one data sample can be written to the buffer per clock cycle, a maximum of 12 samples at a time with the Command block. The read access rate of the Command block buffer is still only 1 sample per clock cycle because of the TTA input memory is cannot be written faster. The memory accessing restricts the Result block buffer access also to 1 sample per clock cycle.

5.3.6 TTA Control

The control over the TTA processor is implemented with the TTA control interface, shown in Figure 5.3. The Command block initiates a new operation with *TTA_initiate* and *TTA_op_out* signals. The generic width *TTA_op_out* signal is used as opcode for the TTA processor to deliver the information where the new data is located on TTA input memory. The opcode was designed to deliver the exact base address of the data, but for this implementation only the data segment index is passed to TTA.

The TTA control interface signal *glock* controls the global locking of the TTA processor. The lock is released when a new operation on TTA is initiated and reserved when TTA

has finished execution. With this implementation the TTA program code halts after finishing execution so the need for the global locking was not necessary when the TTA is done operation.

5.4 TTA Processor

The TTA processor used in this implementation was provided by Tampere University of Technology, Department of Pervasive Computing. It was designed and generated with the Department's TTA-based Co-Design Environment (TCE) toolset [13].

The used architecture is presented in Appendix A. The interconnection network between the functional units was constructed with 5 data buses. In addition to the decoder and global control units, the architecture contains ALU, 32-bit register file of 8 general purpose registers, Boolean register of 2 slots, load-store unit and separate load and store units for the TTA input and output memory accessing.

The blocks considered as special function units are the *Request*, *Resp* and *R4FFT* units. The Request and Resp are considered as input-output units and they perform all the functionality towards outside. The Request unit is responsible for observing the *TTA_initiate* and *TTA_op_out* signals and launching a new operation on the TTA. The Resp unit asserts the *TTA_done* signal and provides the operation code for the Result block with *TTA_op_out* when TTA is done with the FFT.

The FFT functionality was implemented inside the R4FFT unit as a radix-4 Single-Path Delay Feedback (R4SDF) decimation in frequency FFT, described in [14], and for 4096-point size. The basic principle is illustrated in Figure 5.11 for 64-point FFT. The inputs are read in serial form and the *shift registers* (SR) are used for delaying. With the radix-4 DIF approach, the input is divided into $N/4$ size groups, so for 64-point FFT into groups of 16 samples. The butterfly operation of the stage 2 can be started when the first 48 samples have been read into the 16-word SRs. On stage 1, the same principle is applied for groups of 4 samples and for 1 samples at stage 0. With the 4096-point implementation there are six stages with 1024-depth SRs on the stage 5.

The size of the program code for this TTA implementation was 28 lines, with 42-bit instructions. Since the main functionality was inside one SFU, most of the program functionality concerned only the data transfers between the R4FFT unit and the LU and SU.

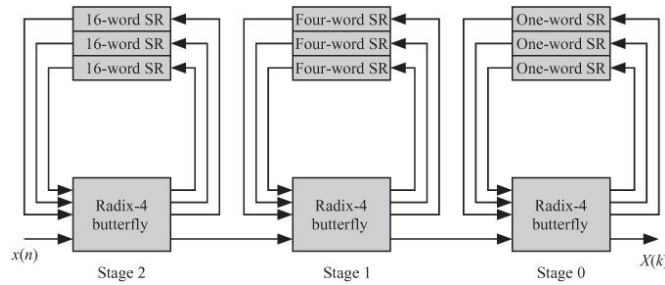

Figure 5.11. Principle for 64-point Radix-4 SDF [2, Fig. 19.7].

5.5 Memories

The memories used in the design are listed in Table 5.3. The TTA input and output memories and the TTA instruction memory were implemented as dual port and others as single port memory. All memories are single clock memories. The FFT engine implementation on TTA has also internal data storages acting as memories but these are not considered as external RAM.

Table 5.3. List of used memories.

Command	Width (bit)	Depth
COP DMEM	128	256
COP IMEM	32	1024
TTA Input MEM	32	12288
TTA Output MEM	32	12288
TTA DMEM	32	256
TTA IMEM	42	128

All the widths of the memories are fixed for the 32-bit complex valued FFT use case, except the COP data memory and TTA instruction memory widths. The COP data memory width is set according to the machine word of the processor, so the 128-bit width is due to this particular implementation. The TTA instruction memory width is determined by the processor architecture and the 42-bit instruction width was generated with this FFT implementation.

The depths of the memories are all selected for this exact implementation. The data and instruction memories could have been set to other depths as well, but these were considered suitable for the processors to operate. The TTA input and output memory depths were selected so that they can each contain three 4096 sample data segments. The segments are indexed to match with the TTA operation code. This was for ensuring uninterrupted data flow between COP and TTA so that COP could still operate on the memories if TTA is for some reason interrupted, and vice versa.

5.6 COP Software

The COP software was written in assembly. Functionality was split into four separate threads to simplify the code and to demonstrate the potential of COP multithreading. The threads' program images were allocated to the instruction memory of COP with equal spacing so that from the 1024 size memory space 256 sized spaces were reserved for each thread. One thread was configured as the *main thread* with system privileges like the permission to spawn other threads as well. The flowchart of the main thread is shown in Figure 5.12. The main thread sleeps most of its lifetime. The thread is awoken if there is an *attention request* in the *Attn* port of COP. The threading mechanism is built for supporting the system privileged threads to be synchronized with the *Attn* port.

With this implementation two kind of attention requests exist. The *TTA_done* signal attached to the *Attn* port and every time a new TTA operation is ready, the port is asserted. Another request is the external *new data* request indicating a new input data availability in the system memory.

Pre-defined load and store base addresses are configured in COP's data memory in system startup. With this implementation 6 memory locations for both the input and result data was reserved from the system memory and the base addresses of these are stored in fixed COP data memory locations. The data memory allocation for the addressing is shown in Figure 5.13. The *loading* and *storing* threads are configured for reading the base addresses for system memory reading and writing from the fixed memory locations, indicated with the names *Loading base address* and *Storing base address* in Figure 5.13. The main thread updates these locations before spawning the threads and performs bookkeeping of the addresses to be configured next.

If new data is asserted to be available, the main thread performs its configurations and spawns first the *acknowledgement* thread. This thread contains no functionality, but its visibility outside COP is used as a confirmation signal that COP has received the info of the new operation. The acknowledging is completed with the COP *Done* port that reflects the threads awake as shown in Figure 5.14. All threads have personal *ID* number related to them and the indexes of the *Attn* port bits corresponds to the IDs of the threads.

After the acknowledgement, the main thread spawns the loading thread and resumes sleep status. If the attention request was indication TTA operation done, the main thread again performs its configuration, spawns the storing thread and resumes sleep.

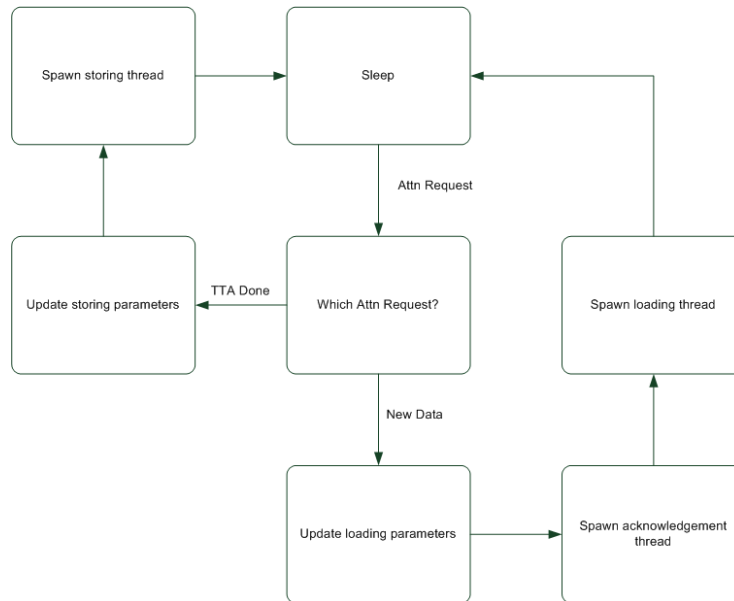

Figure 5.12. Main thread operation.

The operation of the loading thread is illustrated in Figure 5.15. When the thread is spawned it loads the *Loading base address* from data memory fixed location for the system memory reading. Because this implementation was fixed for 4096-point FFT, the number of input samples to be read is hard coded inside the thread source but this could have been provided the same way as the base address. After the thread has the base address and the number of reads stored in its registers, the thread initiates a new AUX transaction the size of 4096. The thread then starts reading the system memory 64 input samples at a time as a single AMBA burst. When the 64 samples are read, a total of five AUX writes are done with 12 samples delivery and one write with 4 samples delivery for the total 64 samples. This is repeated until all the 4096 samples are delivered and the thread resumes sleep state.

The *TTA_done* signal is assigned to the *Attn* port of COP. When the TTA processor informs operation to be completed, the main thread wakes up and checks which attention request was concerned. With the TTA done request the main thread performs the base address configuration, i.e. loads the next *Storing base address* to the fixed data memory location and spawns the thread.

The storing thread operation is shown in Figure 5.16. After being spawned the thread loads the base address for system memory writing and initiates a new 4096 sized read transaction on the Result block. After 16 reads are done for getting 64 samples from the TTA output memory, COP writes the samples to the system memory starting according to the base address. This is repeated until the whole 4096 results are written and the thread resumes sleep state.

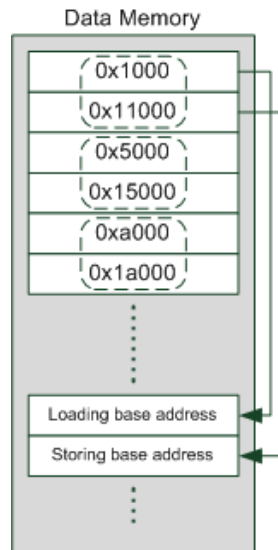

Figure 5.13. Base address allocation in COP data memory. The addresses for loading and storing are allocated in the COP data memory in pairs, indicated with the dashed lines. When the main thread configures loading or storing threads, it writes address information of one pair in the Loading base address and Storing base address memory slots for the threads to use.

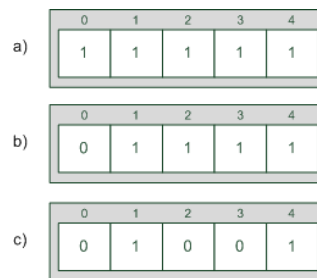

Figure 5.14. Done port operation. In a) all the threads are suspended b) thread with ID no. 0 is in running state c) threads with ID nos. 0, 2 and 3 are in running state.

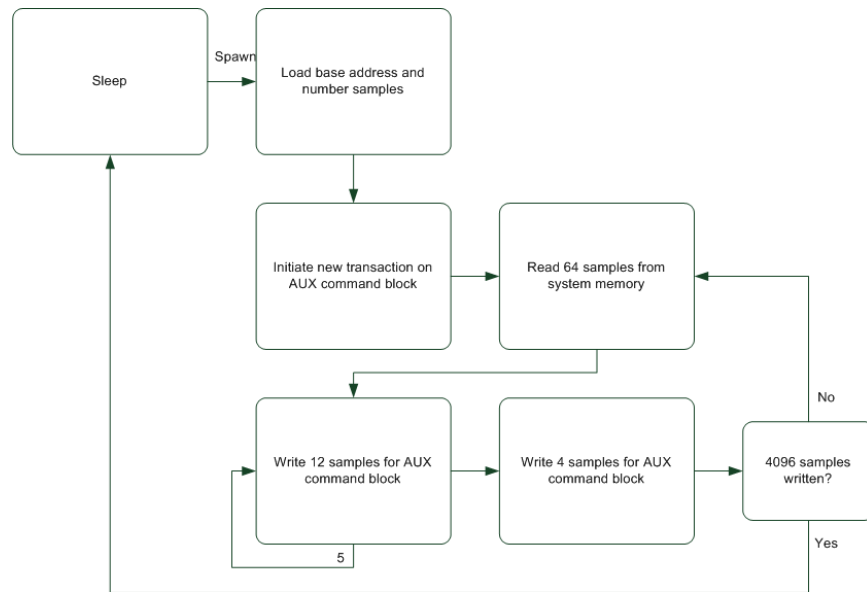

Figure 5.15. Loading thread operation.

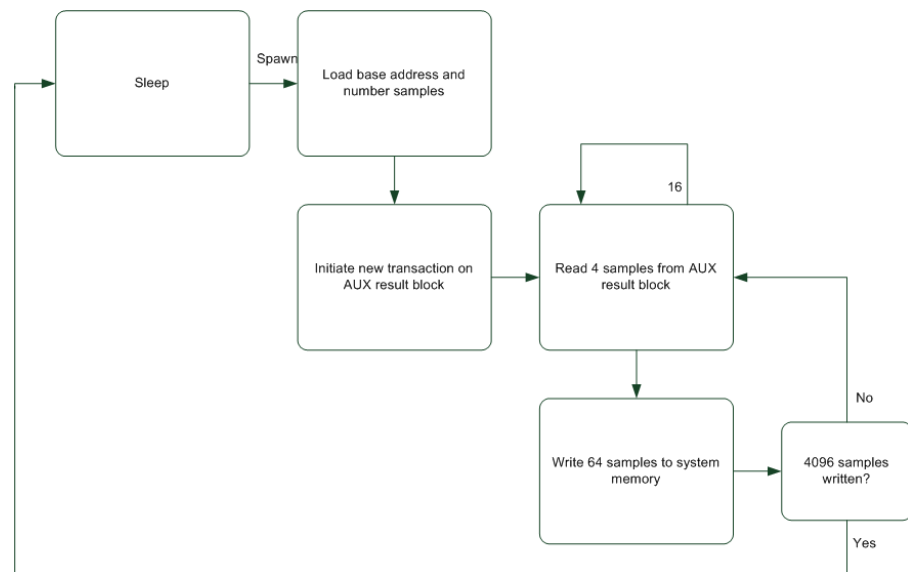

Figure 5.16. Storing thread operation.

6. RESULTS

The design was simulated under a test bench written in SystemVerilog. 32-bit complex valued input data was generated with Matlab into a file and written in the system memory model used in the simulation. The test bench generated interrupts to the *Attn* port of COP to initiate new operation. After finished, the result data was read from the system memory and written into a file. Matlab Fourier operation was used for verifying the results.

The separate operational latencies are listed as cycle counts in Table 6.1 for one 4096-point FFT operation. The full operation took 17892 cycles. The average delay the system memory model created for the AMBA bus accessing was, for 64 samples, around 60 cycles. By including the 8243 delay of the TTA processor, the theoretical latency for one operation in (4.16) can be calculated to be 20278 cycles. This is greater than the simulated full operation latency, because the theoretical value did not consider the Result block reading the TTA output RAM while COP was writing the previous results to the system memory. With the effective buffering inside the Result block, almost every time COP initiated a new read command, the data was already available and was given immediately as the result for the initiating command. Therefore, the timing was limited basically only by the AMBA bus delay.

COP is free from the whole 4096 size operation for 8299 cycles. This is approximately 46% of the total operation time. This time can be used for providing new inputs to the TTA input memory or reading the results from a previous FFT.

Considering the 71.4 μ s LTE symbol duration for 2048-point FFT, the performance of the 4096-point FFT used in this implementation gives some estimation of the usefulness of this design. For example, with 600 MHz clock frequency the latency for one 4096-point FFT operation is \sim 13.7 μ s and for the whole operation \sim 29.8 μ s. Although the 2048-point FFT is the largest size for most of the processing LTE, the 4096-point FFT is still needed for example with the 7.5 kHz subcarrier spacing.

Table 6.1. 4096-samples operation performance.

Operation	Time (cc)
Full operation	17 892
COP input delivery for Command block buffer	4 578
Input delivery for TTA input RAM	4 634
COP output read time	5 015
TTA operation	8 243
COP free of operation	8 299

7. CONCLUSION

In this thesis, the usage of a TTA processor as a hardware accelerator inside a practical design was demonstrated. The drawbacks of the TTA platform, concerning especially the system memory accessing, were compensated by using the Nokia Co-Processor's good DMA properties and external attention requests handling. Also, to demonstrate the usage of the Auxiliary port of COP, the data transferring between COP and the TTA processor was implemented with the AUX command and result mechanism by constructing suitable hardware between the AUX port and the TTA processor.

The usefulness of COP and its AUX port were proved. COP is capable with the DMA operations and can very well be used as a standalone control unit. The Auxiliary port offers a suitable choice for data transferring, as it is capable of delivering data approximately three times faster towards external blocks than the AMBA bus.

The implementation offers a programmable solution for hardware acceleration. Although the TTA FFT functionality was implemented as one fixed size FFT inside a single functional unit, the flexibility of the design could be increased by diversifying the functionality inside the single FFT FU into several individual FUs and letting the program control these for the FFT algorithm operation. This way a different sizes of FFT (the sizes of power of 4 with the radix-4 implementation) could be achieved by using the same building the 4096-point FFT was built on.

The synthesis part of the implementation was not managed to carry in this study with the time margin of the thesis, and, therefore, no area estimations were presented. As there were two processors and lot of memory space involved, the area could form a problem if the design size is a valuable resource. If the design is, however, considered taken into a multimillion transistor implementation, the area might not be problem, and the design proposes a good, robust, programmable solution for hardware acceleration in SoC designs.

REFERENCES

- [1] A. Papoulis, The Fourier Integral and its applications, McGraw-Hill book company Inc. New York, 1962, p.1
- [2] F. Gebali, "The Fast Fourier Transform," in Algorithms and Parallel Computing, John Wiley & Sons, 2011
- [3] Cooley, James W; Tukey, John W. "An algorithm for the machine calculation of complex Fourier series". Math. Comput. vol.19, pages 297–301, 1965
- [4] About 3GPP. [Online]. Available: <http://www.3gpp.org/about-3gpp>, accessed 2016-05-10
- [5] 3GPP LTE. [Online]. Available: <http://www.3gpp.org/technologies/keywords-acronyms/98-lte>, accessed 2016-05-10
- [6] Evolved Universal Terrestrial Radio Access (E-UTRA); Physical channels and modulation. [Online]. Available: <http://www.3gpp.org/DynaReport/36211.htm>, accessed 2016-05-10
- [7] Global Mobile Data Traffic, 2015 to 2020. [Online] Available: <http://www.cisco.com/c/en/us/solutions/collateral/service-provider/visual-networking-index-vni/mobile-white-paper-c11-520862.html>, accessed 2016-05-23
- [8] "OFDM Transmission," in 4G: LTE/LTE-Advanced for Mobile Broadband, Second Edition, Academic Press, 2014
- [9] H. Corporaal, "From VLIW to TTA," in Transport Triggered Architectures: Design and Evaluation, Ph.D. dissertation, Delft Univ. Tech., Sept. 1995.
- [10] "Introduction," in The Essentials of Computer Organization and Architecture, Fourth Edition, Jones and Bartlett Learning, 2015
- [11] AMBA Specifications. [Online]. Available: <http://www.arm.com/products/system-ip/amba-specifications.php>, accessed 2016-05-12
- [12] AMBA[®] AXI[™] and ACE[™] Protocol Specification, Nokia Sharenet D503756349. Limited availability.
- [13] TTA-Based Co-Design Environment. [Online]. Available: <http://tce.cs.tut.fi/>, accessed 2016-05-22
- [14] A. M. Despain, "Fourier Transform Computers Using CORDIC Iterations," in *IEEE Transactions on Computers*, vol. C-23, no. 10, pp. 993-1001, Oct. 1974.

APPENDIX A: IMPLEMENTED TTA PROCESSOR ARCHITECTURE

