

PAPER • OPEN ACCESS

Thermal conductivity of high-performance insulation - a laboratory study. Realistic design values for use in energy-efficient buildings

To cite this article: Malin Sletnes *et al* 2019 *IOP Conf. Ser.: Earth Environ. Sci.* **352** 012046

View the [article online](#) for updates and enhancements.

Thermal conductivity of high-performance insulation - a laboratory study. Realistic design values for use in energy-efficient buildings.

Malin Sletnes, Kristin Elvebakk, Jørn Emil Gaarder, Egil Rognvik, Steinar Grynning

SINTEF Community, Department of Architecture, Materials and Structures,
NO-7465 Trondheim, Norway

malin.sletnes@sintef.no

Abstract. Aerogel insulation blankets could be the solution to some of the challenges encountered when designing (energy efficient) buildings. However, uncertainties regarding performance in different applications and environments may limit their use in cases where they could otherwise be employed to advantage. The purpose of this study was to examine how to best adapt European standards for the measurement of thermal insulation properties to aerogel insulation and highlight important aspects to be aware of when evaluating material parameters. We have systematically varied measurement parameters for thermal conductivity and compressive strength to map the impacts on reported material properties. Furthermore, we have compared the measurement conditions to actual conditions in selected building applications. In conclusion we propose that the European (EN) standard for measuring compression behavior for insulation materials should be revised and clarified with regards to materials that do not exhibit a clear elastic domain. We also suggest that the thermal conductivity of aerogel insulation blankets should be measured with a slight compressive load on the material, but that the calculation of the thermal conductivity should nevertheless be based on the measured sample thickness.

1. Introduction

The energy performance of buildings has increased significantly during the latter decades. One major contributor to this, in cold climates, has been to increase the thermal insulation levels of the buildings. This in turn has led to thicker insulation layers and thicker walls and roofs. High performance insulation materials can contribute to maintaining high insulation levels with reduced wall and roof thicknesses compared to traditional materials. This will decrease the amounts of materials used in the structures and potentially increase sellable floor area of a building.

Although silica aerogels have been known for more than 80 years and have thermal conductivities approximately half those of mineral wool (in the range of 0.012 – 0.018 W/(mK)), the application of aerogel-based products as thermal insulation in buildings is not wide-spread. The main reasons for this are high material costs and dust formation. However, there are some cases where aerogel insulation could be a very good alternative despite the high costs [1-3], such as insulation of thermal bridges, retrofit insulation, and other applications where space restrictions are of essence. Nevertheless, aerogel insulation is rarely considered as an alternative by Norwegian developers or contractors. Part of the reason may be the lack of knowledge and experience on product properties and how to best implement these products into well-known building detail designs. Furthermore, lack of suitable product standards could be an obstacle. There is an ASTM standard for flexible aerogel insulation, and a CUAP [4]. However, there is currently no European EN or ISO standard for aerogel insulation materials, thus complicating the process of product documentation and certification in Europe.

Sometimes adapting existing measuring methods and conditions to new materials is not straight forward. For instance, the European standard for determining compression behaviour of thermal insulation materials, EN 826 [5], is clearly meant for materials which either fracture or weaken prior to



10 % strain or display a clear region of elastic deformation. In this paper, we present the issues that arise upon applying EN 826 standard to measure the compression behaviour of aerogel insulation blankets, which exhibit neither of these properties. Furthermore, most product standards for traditional thermal insulation materials specify that thermal conductivity (λ -value) should be determined directly at measured thickness. However, when this method was applied for aerogel insulation blankets in our previous work [6], we measured λ -values of about 0.017 – 0.018 W/(mK), about 20 % higher than the declared λ -value from the manufacturers (0.014 - 0.015 W/(mK)). In the succeeding discussion, the argument was made that it is important to apply a compressive pressure on the aerogel insulation during measurement of λ -values to avoid air gaps between the sample and instrument. The argument being that aerogel insulation is especially sensitive to air gaps because the thermal conductivity of aerogel insulation is lower than the thermal conductivity of air. Indeed, by compressing the samples during measurement, the measured λ -values improved from 0.018 to 0.015 W/(mK) for the same product [6]. However, the question remains whether measuring with or without compression gives the most realistic λ -value for use in real applications.

Thus, in this study we have focused on systematically changing the applied compressive stress on the sample to investigate the effect on the measured λ -value. The difference from previous work is that we are measuring both the pressure on the sample and sample thickness, whereas in previous work, only sample thickness was measured. Furthermore, we have measured the compressive strength of the insulation, and compared this to expected loads in some typical in-use conditions. In addition to discussing material properties and measurement methodology, we will give some examples which show the significance of the findings for building design with these materials and suggest improvements in measuring techniques which give more realistic design values.

2. Materials and methods

2.1. Materials

The laboratory measurements were performed on commercially available grey aerogel insulation blankets in the form of batts with a thickness of approximately 18 – 20 mm. The aerogel insulation blankets are composite materials of nanoporous silica aerogel in glass/polymer fibre mats. The grey colour is due to synthetic graphite, which has been added in order to reduce radiative heat transfer. Images of the aerogel insulation blanket at different magnifications are shown in Figure 1.

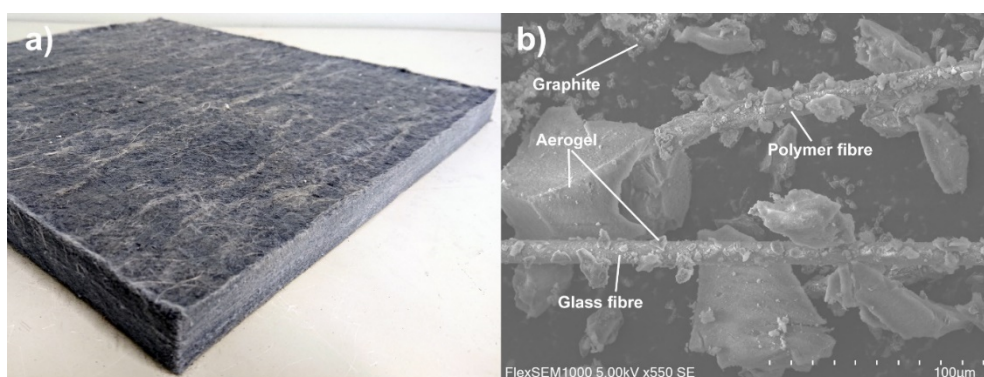

Figure 1 a) Aerogel insulation blanket. b) Electron microscopy (SEM) image showing the components of the aerogel insulation blanket.

2.2. Material characterization

2.2.1. Thermal Conductivity Apparent thermal conductivity λ (W/(mK)) was measured using a heat flow meter (HFM) apparatus in accordance with the governing standard EN 12667 [7]. The compressive stress on the samples during measurement was varied from 0.7 to 20 kPa.

2.2.2. Compressive stress Compressive stress-strain curves were recorded in accordance with EN 826 [7], using a preload of 250 Pa. The specimen size was 10 x 10 cm, and a total of 27 specimens from 4 different production batches were analysed. The sample thickness was measured for each sample prior to measurements. The average sample height was 18.5 mm, with a standard deviation of 0.4 mm.

3. Results and discussion

3.1. Compressive stress

Compressive stress versus strain curves for 27 samples of aerogel insulation blankets from 4 different production batches are shown in Figure 2. According EN 826, the compressive stress at 10 % strain (σ_{10}) should be calculated from the stress-strain curve in the following manner: A line is extended through the (steepest) straight portion of the curve, to the stress corresponding to the preload (250 Pa). The point of intersection is determined as the zero-deformation point. 10 % strain is then calculated starting from the zero-deformation point (i.e. zero-deformation point plus 10 % of the initially measured sample thickness), and σ_{10} is the compressive stress corresponding to this strain. However, EN 826 also states that if there is no distinct straight portion of the curve, this procedure shall not be used. In the alternative method, the zero-deformation point should be defined as the deformation corresponding to a stress of 250 Pa. The two methods are shown in Figure 3, and will be referred to as method A and B, respectively. For aerogel insulation blankets, using these two different approaches to determining the compressive stress give significantly different values, as presented in Table 1. Thus, the declared compressive stress at 10 % strain is very sensitive to the interpretation of the standard. Regardless of the chosen method, the standard deviation for σ_{10} is relatively high, but it is twice as high for Method A than for Method B (see Table 1), reflecting both the divergence in the measured stress-strain curves (Figure 2), and the added insecurity in locating the most linear portion of the curve for extrapolation.

Many commercial suppliers of aerogel insulation blankets do not state σ_{10} , however it appears that those who do use the interpretation that results in the highest declared value. For instance, the EPD of Aspen Spaceloft states $\sigma_{10} \geq 80$ kPa [8], which corresponds well with the values obtained via Method A. However, it is important to be aware that the actual deformation corresponding to a load of σ_{10} according to EN 826 could be significantly higher than 10 %. In average, when using Method A, the attained zero-deformation point already corresponded to 8.7 % actual reduction of the sample height. Adding 10 % strain to this results in an actual deformation of 18.7 % at σ_{10} .

3.2. Practical applications and load cases

For practical use in a building the aerogel blankets will be exposed to different loads. The insulation can be used in both walls, roofs and floors. In roof terrace constructions the aerogel blankets will be exposed to loads from snow, furniture and people, among other things. Examples of loads on the (membrane covered) insulation in a roof terrace construction with different top layers are shown in Table 2. We have tried to identify realistic loads which we assume will appear on the terraces, e.g. loads from heavy persons, furniture, and self-weight of the top layer. We have chosen to use the value for evenly distributed imposed load of 4.0 kN/m² from the Eurocode [9], because this is not easily defined in other ways. The Eurocodes are meant for calculation of the capacity of constructions, and these loads are therefore considered conservative compared to the loads the aerogel blankets are expected to be exposed to in real life. Evenly distributed imposed load could be e.g. load from people and furnishings. Snow loads in Norway vary depending on geographical location [10], however 3.8 kN/m² was chosen as a representative snow load on flat-roof terraces. Since the imposed load was marginally higher than the snow load, and it is assumed that the roof terrace will not be in use during the presence of heavy snow loads, only the imposed load was used in the calculations.

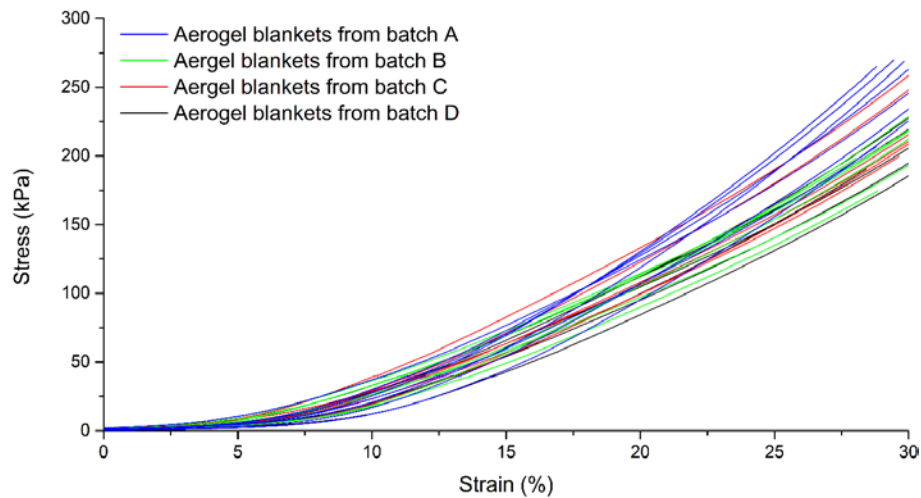

Figure 2 Compressive stress versus strain curves for 27 samples of aerogel insulation blankets from 4 different production batches. The assessment of whether these curves have a distinct straight portion decides the declared compressive stress at 10 % deformation according to EN 826.

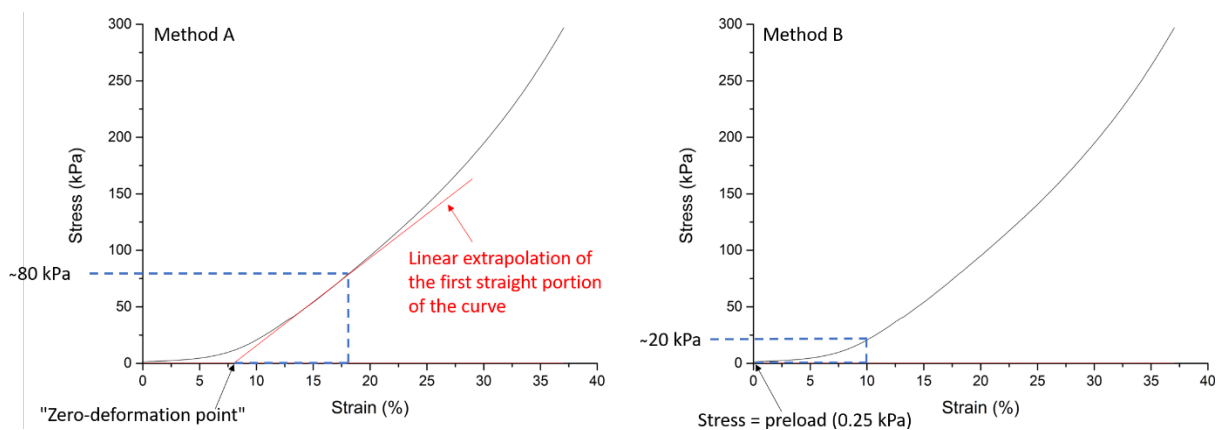

Figure 3 Two different approaches to determining compressive stress at 10% strain for aerogel insulation blankets according to EN 826.

Table 1 Compressive stress at 10% strain for aerogel insulation blankets according to EN 826, using 2 different approaches.

	Number of samples	Average compressive stress at 10 % strain, σ_{10}		Standard deviation	
		Method A [kPa]	Method B [kPa]	Meth. A	Meth. B
Batch A	8	115.0	24.2	15.4	7.8
Batch B	7	88.4	27.3	3.39	7.4
Batch C	6	94.0	27.8	2.84	6.6
Batch D	6	88.7	23.6	2.01	7.5
All samples	27	97.6	25.7	15.3	7.2

We assume that the weight from a heavy person (120 kg) standing on the top of the terrace will represent the most extreme concentrated load. Weight from heavy installations as jacuzzies are not considered relevant in this case, and weight from furniture etc. are considered as lower due to a bigger load distribution area. Considering the loads on top of the terrace construction, the load distribution of the top layer in the terrace will impact the resulting pressure on the aerogel blankets. The top layer will distribute the loads uniformly, as line loads or as concentrated loads, depending on how the top layers

are connected to the terrace construction. In Table 2 we have included load calculations for a 70 mm concrete screed, 50 mm thick concrete tiles on pedestals and a wooden decking.

From Table 2 the most extreme loads will occur if the top layer consists of concrete tiles placed on small pedestals. The total load on the aerogel blankets from a person of 120 kg standing on the concrete tiles directly on top of a pedestal with a diameter of 10 cm will be more than 190 kPa. Increasing the pedestal diameter to 20 cm reduces the load significantly, to less than 45 kPa. As we can see, the dimension of the pedestals will be crucial. When comparing the loads in Table 2 to the σ_{10} for aerogel blankets Table 1, it is clear that all the concentrated loads are higher than the σ_{10} calculated using Method B, whereas most of the loads are lower than the σ_{10} calculated using Method A. Thus, the interpretation of the standard could be decisive for whether one evaluates the aerogel blanket compressive strength to be adequate for use in roof terraces. Therefore, knowledge of the material, and its compression behaviour beyond just the σ_{10} value is important in a design process.

Table 2 Examples of typical loads on the membrane covered thermal insulation in a roof-top terrace construction.

Type of top layer	Load distribution on membrane/insulation [kPa]	Self-load of top layer [kPa]	Imposed load [kPa]		Resulting load on membrane/insulation [kPa]
			Evenly distributed	Concentrated	
Concrete screed	Area load	1.7	4.0	-	5.7
Wooden decking ^a	Line loads	5.4	25.5	-	29.9
			-	49.8	55.2
Concrete tiles ^b (400 x 400 mm)	Point loads Ø20	5.1	20.4	-	25.5
			-	38.2	43.3
Concrete tiles ^b (300 x 300 mm)	Point loads Ø10	11.5	46.0	-	57.5
			-	152.9	172.4
Concrete tiles ^b (400 x 400 mm)	Point loads Ø10	20.4	81.6	-	102.0
			-	152.9	192.8

^a 98 x 73 mm beams with a center-center distance of 60 cm

^b on pedestals with a diameter of 10 or 20 cm

For applications of aerogel insulation blankets, the essential aspect is not the declared value as such, but the performance of the material with respect to the in-use conditions. Our results showed that the modulus (ratio of stress to strain) increases with applied load up to a pressure of at least 800 kPa, significantly higher than the expected loads in in-use conditions. Thus, the material will not fail or weaken if it is subjected to a load higher than the σ_{10} . Consequently, these aerogel insulation blankets could in many cases be considered compression proof, but one should take special care in cases where point and line loads may lead to local depressions and uneven surfaces.

3.3. Thermal conductivity

The λ -values as a function of the applied compressive stress during measurement for aerogel insulation from two different production batches are shown in Figure 4. It is evident that the λ -value decreases with applied compressive stress during measurement. Increasing the pressure from 0.7 kPa to 20 kPa resulted in a decrease in the λ -value of 0.82 ± 0.02 mW/(mK) for sample A and 0.95 ± 0.03 mW/(mK) for sample B compared to 0.7 kPa pressure, a 5.4 and 6.2 % decrease, respectively. However, the apparent improvement in λ -value is due to the decrease in sample thickness (d) during measurement, rather than an increase in thermal resistance. As shown in Figure 5, both the thermal resistance (R) and the sample thickness were reduced upon subjecting the sample to compressive stress during measurement. The λ -value was reduced because the effect of the sample thickness reduction was larger than the reduction in thermal resistance ($\lambda = d/R$). When negating the effect of the sample thickness reduction by calculating the λ -value using the measured sample thickness prior to compression for all

measurements, the λ -value increased slightly, in accordance with the reduction in thermal resistance (Figure 6).

It is important to notice that the reduction in thermal resistance upon compression is very slight. Even under 20 kPa pressure, the thermal resistance was only reduced about 2 – 3 %. This is a potential advantage for aerogel insulation compared to other types of compressible insulation because the thermal resistance of the insulation layer can be considered intact even in applications where the insulation is subjected to compressive loads, such as in the roof-top terraces described above.

In our previous work, we measured λ -values as high as 0.017 – 0.018 W/(mK) for the same materials [6]. All measured values in this study were lower than this. The reason is that we used a preload of at least 0.7 kPa, thus insuring sufficient contact between the whole sample surface and the instrument plates. Sufficient contact is important for correct measurements of thermal conductivity; however, our results still show that it is possible to obtain artificially low λ -values by decreasing the sample thickness during measurement. Hence, in order to get the most realistic λ -values values for aerogel insulation, we propose that the materials should be measured with a compressive load of up to 1 kPa, but the declared lambda value should be calculated based on the nominal thickness.

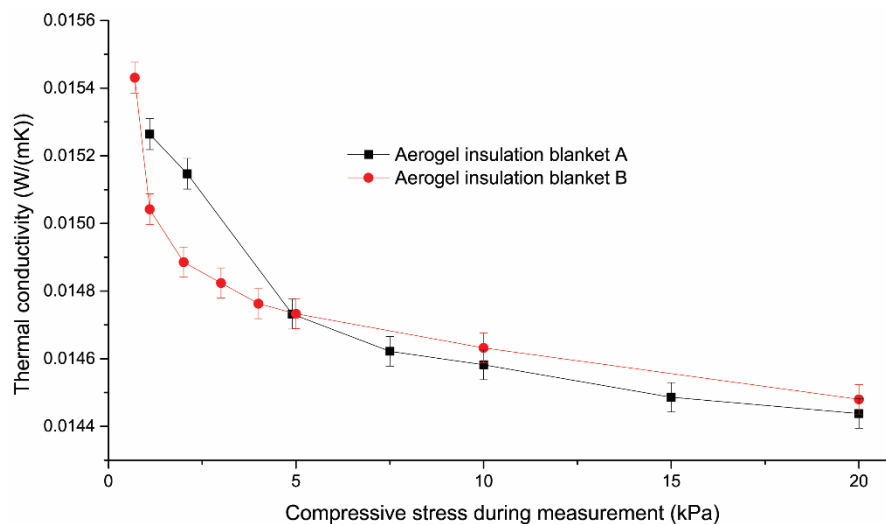

Figure 4 Thermal conductivity of aerogel insulation blankets as a function of compressive stress during measurement. The error bars indicate the expanded standard uncertainty ($k=2$) calculated from the repeatability of the measurements.

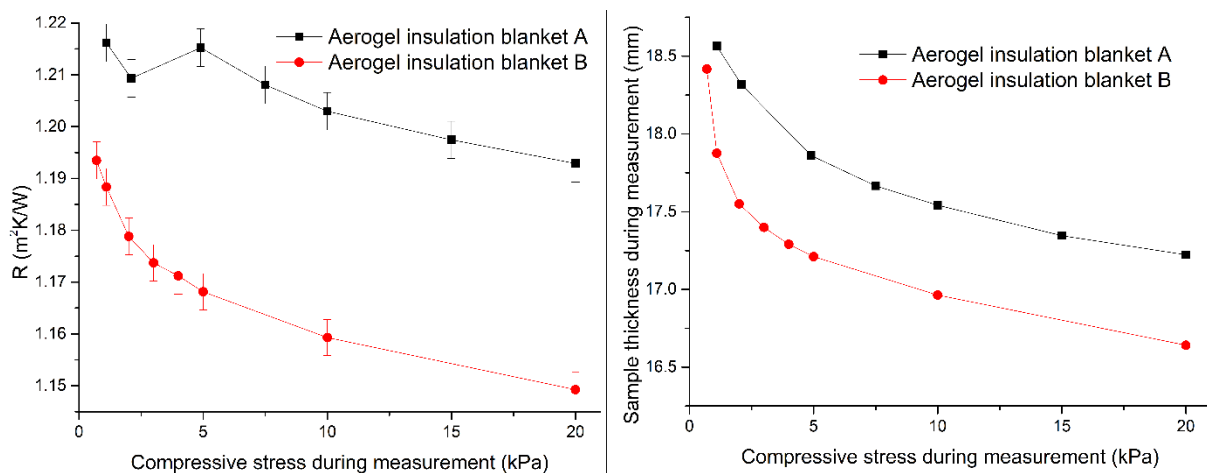

Figure 5 Thermal resistance (R -value) and sample thickness of aerogel insulation blankets as a function of compressive stress during measurement of thermal conductivity. The error bars indicate the expanded standard uncertainty ($k=2$) calculated from the repeatability of the measurements.

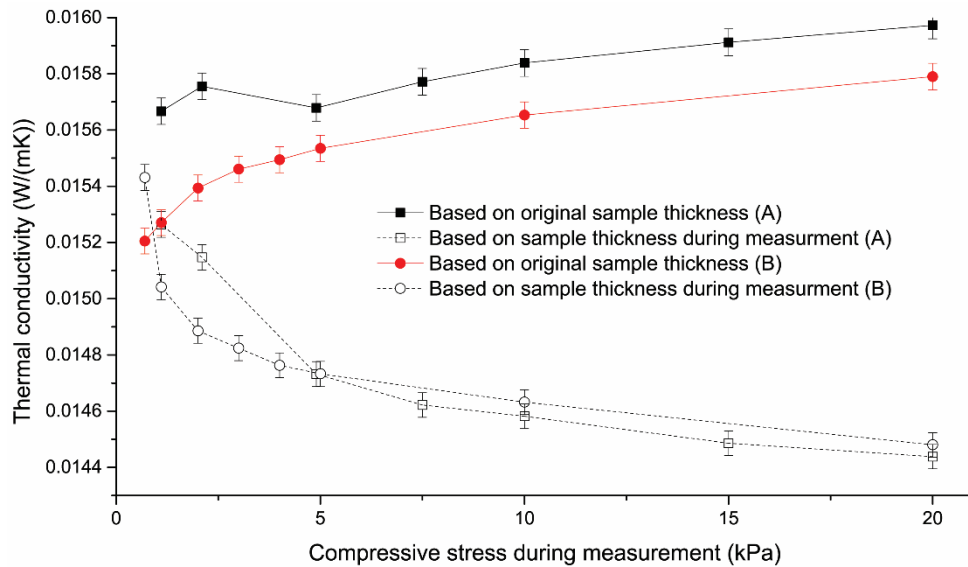

Figure 6 Thermal conductivity of aerogel insulation blankets as a function of compressive stress during measurement calculated based on sample thickness without compression and sample thickness during measurements.

Since the application of aerogel insulation is most relevant in restricted volumes, such as insulation of thermal bridges and as a supplement to traditional insulation materials the practical effect of variations in lambda value due to measurement techniques may in many cases be limited. An example of how variations in the lambda value could impact the heat loss from a thermal bridge at the leading edge of a floor slab (Figure 7) is shown in Figure 8.

An increase of heat conduction coefficient from 0,014 W/mK to 0,018 W/mK (29% increase) in the example will result in an increase of thermal bridge coefficient from 0,131 W/mK to 0,148 W/mK (13% increase). For a given 15 m x 15 m office building with 5 stories, the difference in the resulting heat loss from the thermal bridges in the example above is calculated to 5,1 W/K. This corresponds to an energy demand of approximately 514 kWh over a heating season from October to April in a typical Norwegian climate (using average temperatures for Oslo and a constant indoor temperature equal to 20 °C). Thus, the effect of different measurement conditions for thermal conductivity in this case is not large, but it is nevertheless important to use correct measurement methodology for obtaining declared values, also with regards to competitive conditions in the market.

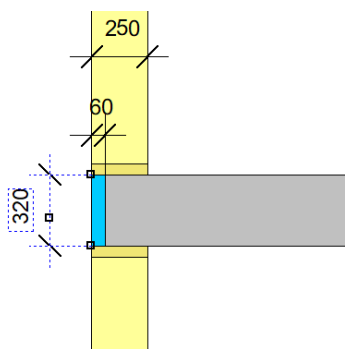

Figure 7 Aerogel insulated thermal bridge. The walls are constructed using insulated framework and the floor is a hollow-core concrete slab protruding 190 mm into the wall.

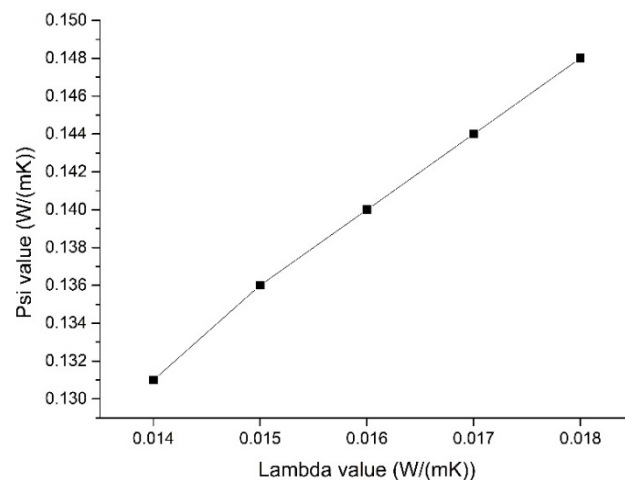

Figure 8 Heat loss from thermal bridge as a function of lambda value.

4. Conclusion and further work

This study has demonstrated some of the issues that arise upon applying European (EN) measurement standards for thermal insulation to measure the compression behaviour and thermal conductivity of aerogel insulation blankets. The methodology for calculating the compressive strength at 10 % strain in EN 826 is unclear due to the shape of the stress-strain curves for aerogel insulation. Applying two different methodologies gave average σ_{10} values of 97.6 kPa and 25.7 kPa, respectively. The lower value is not sufficient to withstand typically expected loads on a roof-top terrace, however the aerogel insulation will not fail or weaken if exposed to loads exceeding σ_{10} . Hence, those wishing to apply aerogel insulation in constructions where it will be subjected to compressive load should consult the stress-strain curve rather than simply relying on the reported value for σ_{10} . For the measurement of thermal conductivity of aerogel insulation blankets, we propose that the materials should be measured with a compressive load of up to 1 kPa, but the declared lambda value should be calculated based on the nominal thickness. This work highlights the need for a governing European product standard for aerogel insulation, and the adaptation of existing measurement standards to new types of thermal insulation.

5. Acknowledgements

This work was part of the IPN project SuperIsol, owned by Isola AS and funded by the Research Council of Norway under the large-scale programme for energy research (ENERGIX), project number 282389.

References

- [1] U. Berardi and L. Ákos, "Thermal bridges of metal fasteners for aerogel-enhanced blankets," *Energy and Buildings*, vol. 185, pp. 307-315, 2019.
- [2] U. Berardi, "Aerogel-enhanced systems for building energy retrofits: Insights from a case study," *Energy and Buildings*, vol. 159, pp. 370-381, 2018.
- [3] E. Cuce, P. M. Cuce, C. J. Wood, and S. B. Riffat, "Optimizing insulation thickness and analysing environmental impacts of aerogel-based thermal superinsulation in buildings," *Energy and Buildings*, vol. 77, pp. 28-39, 2014.
- [4] CUAP 12.01/36 Fibre Reinforced Silica Aerogel Thermal Insulation, 2011.
- [5] EN 826:2013 Thermal insulating products for building applications - Determination of compression behaviour.
- [6] M. Sletnes, B. P. Jelle, and B. Risholt, "Feasibility study of novel integrated aerogel solutions," *Energy Procedia*, vol. 132, pp. 327-332, 2017.
- [7] EN 12667:2001 Thermal performance of building materials and products - Determination of thermal resistance by means of guarded hot plate and heat flow meter methods - Products of high and medium thermal resistance.
- [8] "Environmental Product Declaration of Spaceloft Aerogel Insulation," ed: Aspen Aerogels Inc., 2015.
- [9] NS-EN 1991-1-1:2002+NA:2019 Eurokode 1: Laster på konstruksjoner - Del 1-1: Allmenne laster - Tetthet, egenvekt og nyttelaster i bygninger
- [10] NS-EN 1991-1-3:2003+A1:2015+NA:2018 Eurokode 1: Laster på konstruksjoner - Del 1-3: Allmenne laster – Snølaster