



International Journal of Sciences: Basic and Applied Research (IJSBAR)

ISSN 2307-4531

<http://gssrr.org/index.php?journal=JournalOfBasicAndApplied>



## Computer Modeling and Study of Force Characteristics of Eccentric Drill Chuck

Juriy Nikolayevitch Kuznetsov<sup>a</sup>, Penka Milkova Nedeltcheva<sup>b</sup>, Hasan Al-Dabbas<sup>c\*</sup>

<sup>a</sup> National Technical University of the Ukraine "Kiev Politechnical Institute" (Ukraine)

<sup>b</sup> Gabrovo Technical University (Bulgaria)

<sup>c</sup> Philadelphia University ( Jordan )

### Abstract

When clamping tool of various diameters on the eccentric cams - differently in contact with the tool and taper sleeve, which leads to a change in power characteristics and elastic - the stress state of the interacting elements in manufacturing technology, defining force characteristics can be used for various schemes and designs of wide-range eccentric drilling, milling chucks, analytical relationships can serve as a quantitative criterion for choosing the best options from a variety of synthesized cartridges various geometric rounds ( design factors ) . In order of succession and the creation of working technical documentation in CAD system Solid Works parametric computer model created consideration girth tool shank diameters from 0.5 to 10mm.

### 1. Introduction

The search for new technical solutions of the instrumental clamp chucks lead to creation of eccentric drilling chucks (EDC) [1-3] of original design that comply with the requirements of modern technologies. They were synthesized using a differential and morphological method [3, 7] and are aimed for locking predominantly drills, reamers, countersink bits, millers and other similar tools with a cylindrical shank. These chucks are characterized by a stability of structure, small diameter dimensions and weight, which allow using them for high speed cutting [8].

Figure 1 shows a design of such a chuck with a wrench (not shown). The chuck body 4 has three eccentric coaxial cams 2 that can turn due to cylindrical shifters. A ring spring 5 in a body groove and flats on shifters keep cams 2 in a permanent contact of their external conic surface with inside conic surface of a flared sleeve 3. The flared sleeve has inside flat thread and when turning along the external thread of shims 6 and interacting with eccentric cams 2 gets tightened and preliminary clamps a cylindrical shank of tool 1.

A final preload of the system is performed by the eccentrics 7 located in cylindrical bored holes of body 4 and through-holes of shims 6. The latter when the eccentrics 7 are turned with the help of a hex-wrench (not shown on the fig. 1) move shims 6 in axial direction, and the latter in their turn move the flared sleeve 3 till the tool is firmly locked.

In order to reduce radial beat of the tool it is advisable to evenly tighten all the shims 6, i.e. turn all the eccentrics 7, or to make a general jacket instead of shims [1, 2].

\* Corresponding author.

E-mail address: [drdabbas@engineer.com](mailto:drdabbas@engineer.com).

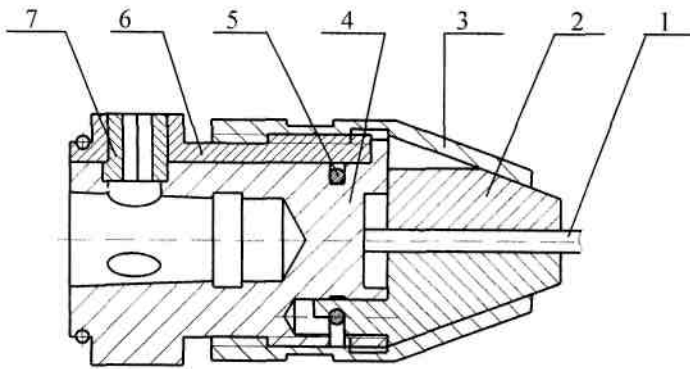

**Fig. 1.** Eccentric drill chuck with a wrench

The main requirement for clamping mechanisms is connected with their functional purpose, and namely providing a necessary clamping force that prevents turning and sliding of the clamped tool or rough work-piece due to a rotational moment and axial cutting forces, or turning in relation to a support point due to bending moments, and also due to their combined effect [7].

The aim of the work is to study force characteristics of EDC which enables to increase the rigidity of the system “clamped chuck – tool” on metal-cutting machine tools.

The topical character of the work is determined by absence of theoretical and experimental studies and of method of calculation and designing of EDC, which reduces their reliability and stability of the basic technical characteristics, thus limiting and checking their broad implementation.

## 2. Pre-Requisites And Means Of Reaching The Set Aim

With the aim of studying and also making working technical documentation, a parametric computer model of analysis of EDC covering diameters of tool shank 0.5 to 10 mm was created in the medium CAD of the system SolidWorks (fig. 2).

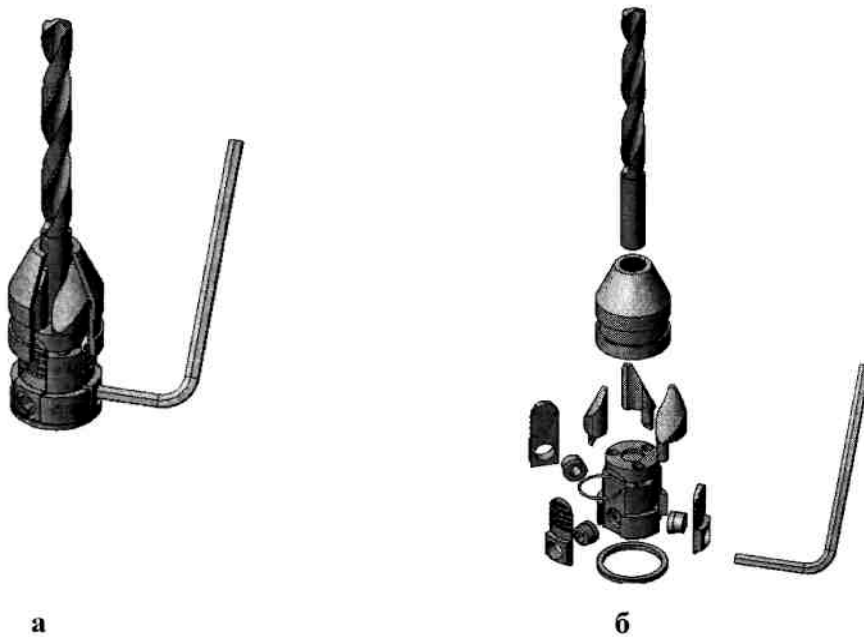

**Fig. 2.** General view of the eccentric drill chuck with a wrench EDC-10 assembled (a) and disassembled (b).

When tools of different diameters are clamped the eccentric cams contact the tool and flared sleeve in a different ways (fig.3), which brings about the change of the force characteristics and elastic-and-strained state of interfacing elements.

The study of the force characteristics of EDC conducted with CosmosWorks, a specialized application for SolidWorks [4-6], is aimed for solving tasks of solid deformable body mechanics with the finite elements method like solving a linear static task. The form and dimensions of parts of the structure under analysis enable to use volumetric isoparametric tetrahedrons as a type of finite elements. As long as the contact finite elements are absent in a visible form in the program, on the basis of indirect observations one can state that taking into account the corresponding border conditions determining the contact, a global matrix of the system rigidity is changed between conic surfaces of cams and sleeve as well as between cylindrical surfaces of cams and shank of the clamped tool.

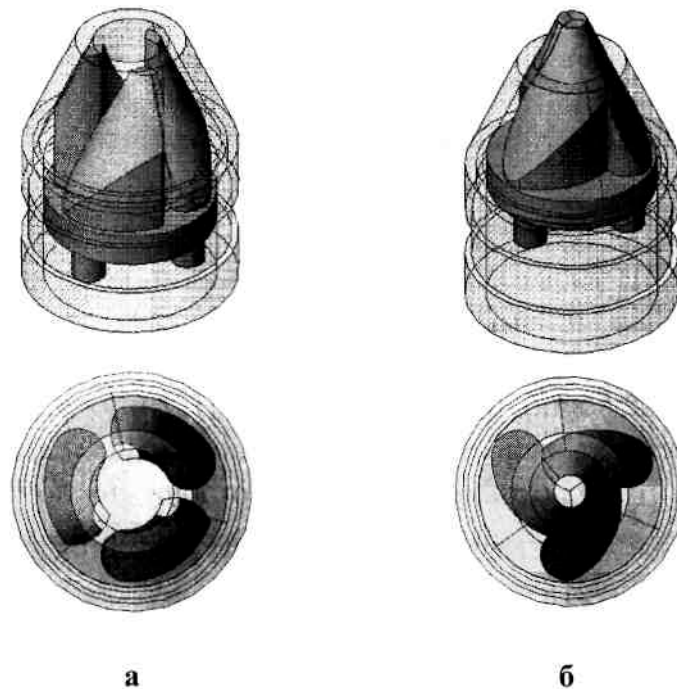

**Fig. 3.** Positions of the eccentric cams EDC when the cams are apart for a maximum tool diameter (a) and brought together for a minimal tool diameter (b).

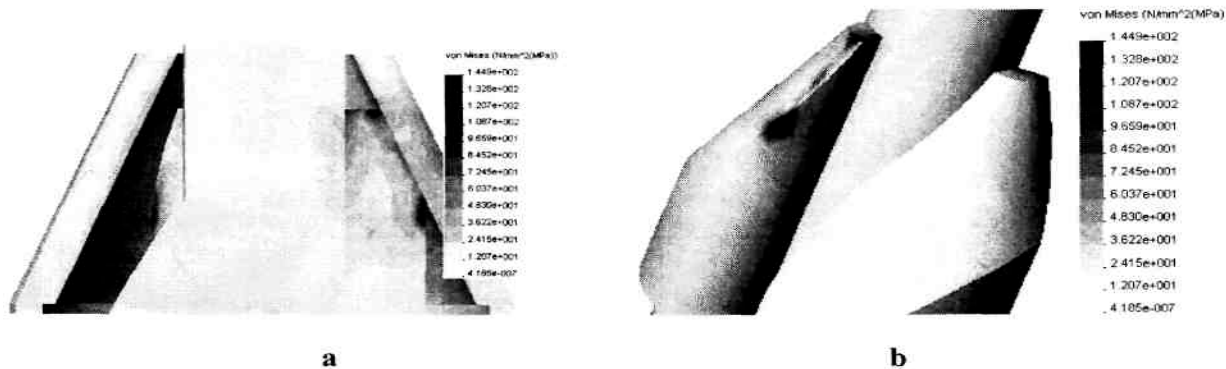

**Fig. 4.** Equivalent loads in EDC.

Fig. 4 shows charts of equivalent loads in the chuck when edges of conic surfaces of the eccentric cams and of the sleeve are equal. The clamp of the tool with a maximum shank diameter  $d_{max} = 10 \text{ mm}$  is done by radial force of the clamp from the side of the eccentric cam that is  $T = 450 \text{ N}$ .

Characteristics of materials of cam and flared sleeve in accordance with ISO: elastic modulus  $E = 2.1 \times 10^{11} \text{ Pa}$  and  $E_T = 0.79 \times 10^{11} \text{ Pa}$ ; Poisson ratio  $\mu = 0.28$ ; coefficient of heat transmission by conductivity  $k = 50 \text{ W/(mK)}$ ; specific heat capacity  $c = 460 \text{ J/(kgK)}$ ; thermal expansion coefficient  $\alpha_t = 1.3 \times 10^{-5} \text{ m/(mK)}$ ; density  $\rho = 7700 \text{ kg/m}^3$ . Automatically made finite elements net contains 46586 elements and 72359 ties, friction coefficient between contacting conic surfaces and adhesion coefficient between surfaces of clamping cams and tool are taken to be 0.15 [7].

The largest contact loads are in cams towards element of conic surface along which the cam is pressed against inside conic surface of the sleeve. The loaded state of part in the chuck was estimated according to the fourth theory of failure:  $\sigma_{eqIV} \leq [\sigma]$ .

### 3. Force Characteristics Of EDC

The object under analysis was the radial clamping force with which each of eccentric cams of the chuck clamps the tool. It is determined as the force of contact interaction of the eccentric cam with the shank of the clamped tool as the result of axial movement of the flared sleeve of the chuck.

The analysis of the EDC structure showed that the main factor considerably influencing the magnitude and stability of the radial clamping force  $T$  is the deviation of the angular dimension of the conic surface of the eccentric cam and inside conic surface of the sleeve. The clamping force is greatly influenced by the difference in tip angles of the conic surface of cam and sleeve, i.e. angular play  $\Delta\alpha = \alpha_k - \alpha_{sleeve}$ , where  $\alpha_k$  is tip angle of the conic surface of cam and  $\alpha_{sleeve}$  is the tip angle of the inside conic surface of sleeve (fig. 5).

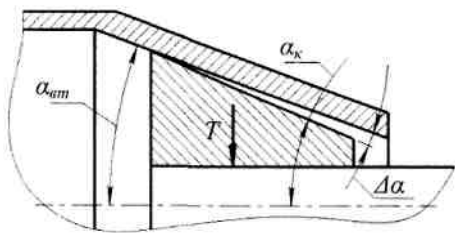
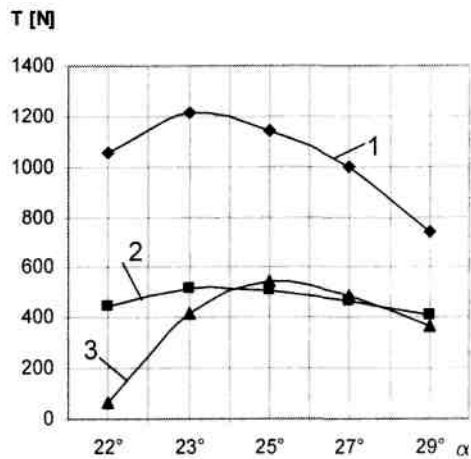

Fig. 5. Nature of interaction of the eccentric cam with the flared sleeve.



**Fig. 6.** Change of clamping force depending on tip angle of conic surface, with different angular plays of  $\Delta\alpha$ : 1 -  $0^\circ0'$ ; 2 -  $0^\circ10'$ ; 3 -  $0^\circ20'$ .

In order to determine the best tip angle of the conic surface which must be more than the angle of decalage, and also in order to provide the maximum force of clamp  $T$  a numeric test was conducted on the basis of the developed finite element model of the chuck.

Fig. 6 shows graphical interpretation of the study results with the maximum diameter of the clamped surface with the diameter  $d = 10\text{ mm}$  (fig. 3, a) and angle deviations  $\Delta\alpha$  of  $0^\circ0'$ ;  $0^\circ10'$  and  $0^\circ20'$ , correspondingly.

The chuck design requires the necessary clamping force taking into account centrifugal forces. The centrifugal force affects all the parts of the chuck causing deformations that influence its force characteristics.

With the aim of theoretical analysis of the influence of centrifugal forces and deviations of tip angle of the conic surface of cam and sleeve on force characteristics of EDC the following were taken as variables: rotation frequency  $n$  for static state with  $n = 0\text{ min}^{-1}$  as well as for dynamic with  $n = 6000$  and  $12000\text{ min}^{-1}$ ; deviations of tip angle of the conic surface of cam and sleeve of  $\Delta\alpha$  of  $0^\circ0'$ ;  $0^\circ10'$  and  $0^\circ20'$ ; diameters of the tool shank with  $d = 1, 6$  and  $10\text{ mm}$ .

The results of the numeric test are summarized and shown in fig. 7. The clamping forces were determined under the condition of maximum equivalent loads in the chuck of 420 Mpa.

The main conclusions are as follows:

1. The magnitude and deviations of angular dimensions of the conic surfaces of eccentric cams and flared sleeve provide the greatest effect on reduction of the clamping force that is created in the static state.
2. The centrifugal force caused by disbalance of weights of chuck parts (mainly eccentric cam) within the limits of the set broad range of rotation frequencies almost does not affect the clamping force, which allows rating such chucks as high speed and broad range chucks.

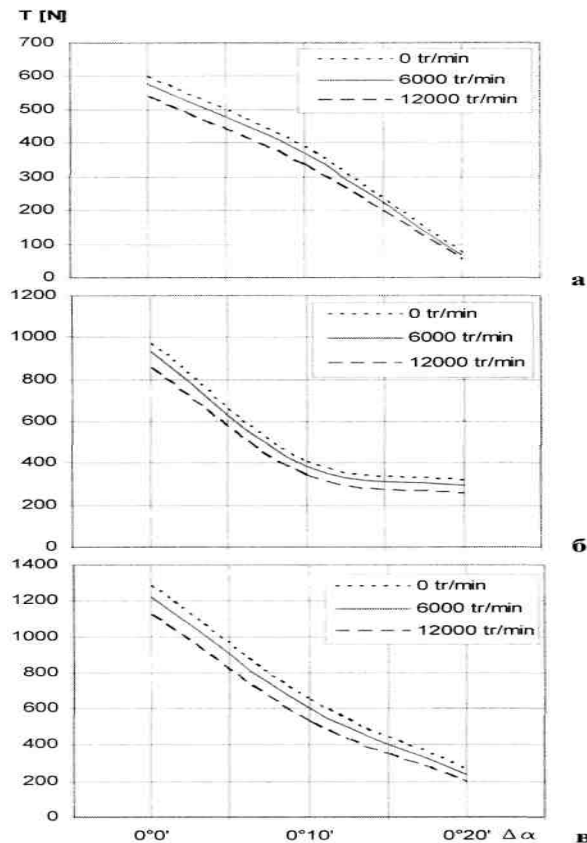

**Fig. 7.** Change of radial clamping force depending on angular play  $\Delta\alpha$  with diameters of the tool shank  $d$  being 1 mm (a), 6 mm (b) and 10 mm (c) and different rotation frequencies  $n$ .

#### 4. CONCLUSION

The parametric model of eccentric drill chucks developed in CAD-system of SolidWorks, modeling and study of force characteristics using the method of finite elements with the help of the specialized application for CosmosWorks enabled to increase the stability of characteristics of the system “clamped chuck – tool” on metal-cutting machine tools at high rotation frequencies.

The results of the study of the force characteristics of EDC allow performing grounded determination of limits for angular dimensions of the contacting conic surfaces during development of working technical documentation.

#### References

- [1] Kuznetsov J.M., Nedeltcheva P.M., Hasan Al-Dabbas. Systemic and morphological approach for synthesis of broad-range eccentric drill-and-milling chucks// News of TU. – Gabrovo. – V. 33. – 2006.
- [2] Patent of the Ukraine No. 28198. A clamping chuck. MPK B23B 31/02, 31/04, 31/12, 31/20 (authors: Kuznetsov J.M., Weissman V.G.).
- [3] Kuznetsov J.M. Theory of solving of creative tasks. – K.: TOV“ZMOK” – PP“GNOSIS”, 2003. – 345 p.
- [4] SolidWorks – Basic course. TekhnoLogika EOOD, Sofia, ISBN 954-9334-04-X, 2004. – 382 p.
- [5] Grigoriv B. SolidWorks 2005. Practical guidance. Sofia: Publishing House ADSYS, ISBN 954-91520-2-2, 2005. – 355 p.
- [6] David Murray. SolidWorks. Second edition. Moscow: Publishing House LORI, ISBN 5-85582-197-8, 2003. – 604 p.
- [7] Kuznetsov J.M., Vatchev A.A., Syarov S.P., Tservenkov A.J. Self-adjusting clamping mechanisms: Reference-book. – K: Tekhnika, 1998. 222 p.
- [8] Kuznetsov J.M. Principles of making of technological tooling for high speed and precise processing on metal-cutting machine tools. // Report on a jubilee scientific conference, Plovdiv, 10.11.2006.