

Technical University of Denmark



Analysis and design of complex impedance transforming marchand baluns

Michaelsen, Rasmus Schandorph; Johansen, Tom Keinicke; Tamborg, Kjeld M.

Published in:

Proceedings of 2014 20th International Conference on Microwaves, Radar, and Wireless Communications

Link to article, DOI:

[10.1109/MIKON.2014.6899854](https://doi.org/10.1109/MIKON.2014.6899854)

Publication date:

2014

[Link back to DTU Orbit](#)

Citation (APA):

Michaelsen, R. S., Johansen, T. K., & Tamborg, K. M. (2014). Analysis and design of complex impedance transforming marchand baluns. In Proceedings of 2014 20th International Conference on Microwaves, Radar, and Wireless Communications IEEE. DOI: 10.1109/MIKON.2014.6899854

DTU Library

Technical Information Center of Denmark

General rights

Copyright and moral rights for the publications made accessible in the public portal are retained by the authors and/or other copyright owners and it is a condition of accessing publications that users recognise and abide by the legal requirements associated with these rights.

- Users may download and print one copy of any publication from the public portal for the purpose of private study or research.
- You may not further distribute the material or use it for any profit-making activity or commercial gain
- You may freely distribute the URL identifying the publication in the public portal

If you believe that this document breaches copyright please contact us providing details, and we will remove access to the work immediately and investigate your claim.

Analysis and Design of Complex Impedance Transforming Marchand Baluns

Rasmus S. Michaelsen^{1,2}, Tom K. Johansen¹, Kjeld M. Tamborg²,

¹Technical University of Denmark, Department of Electrical Engineering
2800 Kongens Lyngby, Denmark

Email: rsmi@elektro.dtu.dk

²Weibel Scientific A/S
3450 Allerød, Denmark

Abstract—A new type of Marchand balun is presented in this paper, which has the property of complex impedance transformation. To allow the Marchand balun to transform between arbitrary complex impedances, three reactances should be added to the circuit. A detailed analysis of the circuit gives the governing equations. To verify the theory, a design and electromagnetic simulation of a lumped element Marchand balun is made in a SiGe BiCMOS technology. The lumped element implementation is favorable because capacitors are placed where the additional reactances should be added. Thus it is possible to absorb a positive reactance by reducing a capacitor. At the design frequency of 10.5 GHz it matches 50Ω to $50 - j66\Omega$. It has an insertion loss of 5.1 dB, an input reflection of -20.8 dB, as well as phase and magnitude imbalance better than 0.2° and 0.12 dB, respectively.

Index Terms—Balun, Marchand balun, Complex impedance transformation, MMIC.

I. INTRODUCTION

Baluns are used to transform an unbalanced input signal to a balanced output signal. This is an essential functionality in many microwave circuits, e.g. differential amplifiers and balanced mixers. Baluns can be characterized by a group of parameters. Magnitude balance and phase balance describes how well the balun performs the task of transforming an unbalanced signal to a balanced signal. As for all microwave circuits, input reflection must also be considered. For active baluns gain, noise and linearity is also important parameters. The passive baluns do not suffer from noise or linearity issues, but may suffer from excessive loss. The passive balun has a larger dynamic range, as it does not contribute with neither noise nor decreased linearity.

One type of passive balun structure is the so-called Marchand balun [1]. The Marchand balun consists of two sets of coupled lines connected together. The Marchand type balun has found widespread application, due to its wide bandwidth. Several modifications and enhancements has been reported, among these are techniques for bandwidth enhancement [2], miniturization [3], tuning of phase balance [4] or center frequency [5] and impedance scaling [6]. The impedance scaling is only suggested between real valued generator and load impedances.

The purpose of this paper is to give a suggestion for a Marchand type balun that can do impedance transformation

between arbitrary complex impedances. By having the complex impedance matching as part of the balun circuit the total circuit size is minimized, as there is no need for additional matching inductors to the active devices. Also the low-Q of inductors typically found in silicon based technologies make it desirable to avoid them due to added loss.

In [7] the idea of using a coupled line, reactively loaded on the thru and coupled ports, for complex impedance matching was suggested. We will expand this idea to the Marchand balun, constructing it of two of such types of coupled lines. To the authors knowledge, this is the first demonstration of a Marchand balun with complex impedance transformation properties.

This paper will first give an analysis of the proposed impedance transforming Marchand balun. This will be followed by a design suggestion in a SiGe technology. Then we use electromagnetic (EM) simulations on the implementation to verify the analysis and design.

II. ANALYSIS

In this section we will provide an analysis of the impedance matching Marchand balun. A schematic of the proposed circuit for the impedance transforming Marchand balun is shown in figure 1, where port 1 (P_1) is driven by a generator with impedance $Z_G = R_G + jX_G$ and port 2 (P_2) and 3 (P_3) is terminated in $Z_L = R_L + jX_L$.

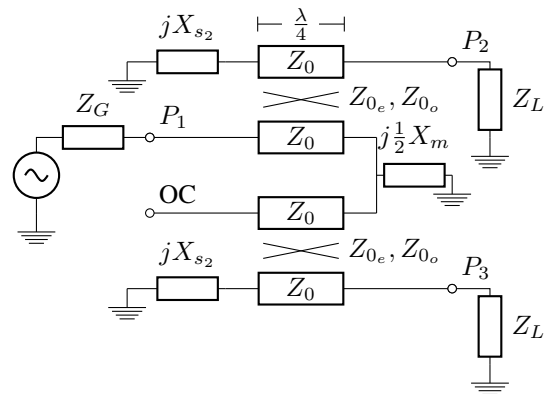

Fig. 1. The modified Marchand balun with complex impedance matching properties.

The ideal balun behavior for a three port network can be described by S-parameters

$$S_{21} = -S_{31} \quad (1)$$

$$S_{11} = 0. \quad (2)$$

Ideally, there should be no reflected power from the load and the other S-parameters should not influence performance. Of course this is not the case for real world applications, but the most important ability of a balun is still as expressed above.

To analyze the Marchand balun the approach described in [6] is used. This approach uses the even-/odd-mode analysis [8] to investigate a symmetric network. The balun can be seen as a symmetric four-port with the fourth port terminated in an open circuit. In the analysis we treat the fourth port similar to port one, thus creating a plane of symmetry.

The requirement of balun behavior, i.e. (1) and (2), can be expressed from the even and odd mode circuits, as [6]

$$T_{\text{even}} = 0 \quad (3)$$

$$Z_{\text{even}} + Z_{\text{odd}} = 2Z_G^* \quad (4)$$

where T_{even} is the even mode transmission coefficient, Z_{even} and Z_{odd} is the impedance seen into the even and odd mode circuits, respectively, and Z_G^* denotes the complex conjugate of Z_G .

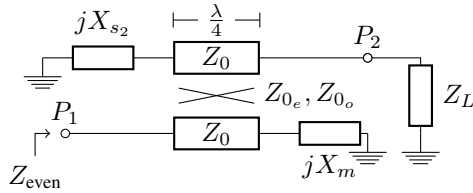

Fig. 2. The even mode circuit.

The even mode circuit of the modified Marchand balun is shown on figure 2. In [7] the two-port Z-parameters for a couple line loaded at the coupled and thru port with Z_{s2} and Z_m respectively is given as

$$\bar{Z} = \begin{bmatrix} \frac{Z_{s2} Z_+^2}{4Z_m Z_{s2} + Z_-^2} & \frac{-jZ_-}{2} + \frac{\frac{1}{2}jZ_+^2 Z_-}{4Z_m Z_{s2} + Z_-^2} \\ \frac{-jZ_-}{2} + \frac{\frac{1}{2}jZ_+^2 Z_-}{4Z_m Z_{s2} + Z_-^2} & \frac{Z_m Z_+^2}{4Z_m Z_{s2} + Z_-^2} \end{bmatrix} \quad (5)$$

where Z_+ and Z_- is $Z_{0e} + Z_{0o}$ and $Z_{0e} - Z_{0o}$, respectively, Z_{0e} and Z_{0o} is the even and odd mode characteristic impedance of the coupled line.

The requirement of (3) is fulfilled if $Z_{21} = 0$, which from (5) can be reduced to

$$4X_m X_{s2} - Z_-^2 + Z_+^2 = 0, \quad (6)$$

where it has been used that $Z_{s2} = jX_{s2}$ and $Z_m = jX_m$. Because of the requirement $Z_{21} = 0$ then the even mode impedance is not dependent on the load condition and we have

$$Z_{\text{even}} = \frac{Z_{s2} Z_+^2}{4Z_m Z_{s2} + Z_-^2}. \quad (7)$$

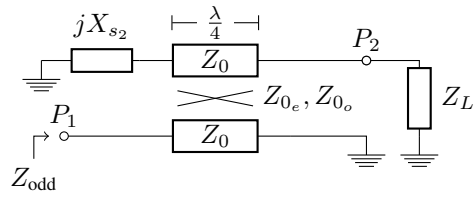

Fig. 3. The odd mode circuit.

The odd mode circuit of the modified Marchand balun is shown on figure 3, it consists of a coupled line with a reactive load on the coupled port and a short circuit on the thru port. The two port Z-parameters for the odd mode circuit is then given as (5) with $Z_m = 0$,

$$\bar{Z}|_{Z_m=0} = \begin{bmatrix} \frac{Z_{s2} Z_+^2}{Z_-^2} & j \frac{Z_+^2 - Z_-^2}{2Z_-} \\ j \frac{Z_+^2 - Z_-^2}{2Z_-} & 0 \end{bmatrix}. \quad (8)$$

The odd mode impedance can be found as the input impedance of the loaded two port

$$Z_{\text{odd}} = \frac{Z_{s2} Z_+^2}{Z_-^2} - \frac{(Z_+^2 - Z_-^2)^2}{4Z_-^2 Z_L}. \quad (9)$$

By inserting (7) and (9) into (4) and splitting the equation in a real and imaginary part gives

$$R_G = \frac{1}{8} \frac{(Z_+^2 - Z_-^2)^2 R_L}{Z_-^2 (R_L^2 + X_L^2)} \quad (10)$$

$$X_G = \frac{1}{2} \frac{X_{s2} Z_+^2}{Z_-^2} - \frac{1}{8} \frac{(Z_+^2 - Z_-^2)^2 X_L}{Z_-^2 (R_L^2 + X_L^2)} + \frac{1}{8} \frac{X_{s2} Z_+^2}{\frac{1}{4} Z_-^2 - X_m X_{s2}}. \quad (11)$$

The condition $X_G = 0$ is chosen to simplify the following equations, but a more general approach is possible also for $X_G \neq 0$. The three equations (6), (10) and (11) has four design parameters, X_{s2} , X_m , Z_{0o} and Z_{0e} as free variables. From (6) one gets

$$X_m = -\frac{1}{4} \frac{Z_+^2 - Z_-^2}{X_{s2}}. \quad (12)$$

Then inserting (12) in (11) to get

$$X_{s2} = \frac{1}{4} \frac{X_L (Z_+^2 - Z_-^2)^2}{(Z_-^2 + Z_+^2) (R_L^2 + X_L^2)} \quad (13)$$

Finally from (10) we get

$$\frac{1}{Z_{0o}} - \frac{1}{Z_{0e}} = \frac{1}{R_G} \sqrt{\frac{2}{\alpha}} \quad (14)$$

$$\text{where } \alpha = \frac{R_L^2 + X_L^2}{R_G R_L} \quad (15)$$

Observe that for the case of transformation to a real valued load, i.e. $X_L = 0$, (13) gives $X_{s2} = 0$, a short circuit, (12) gives $X_m \rightarrow \infty$, an open circuit, and the impedance scaling factor becomes $\alpha = \frac{R_L}{R_G}$, which is the case for the regular Marchand balun [9].

III. DESIGN PROCEDURE AND SIMULATION RESULTS

In this section we will describe the design procedure for the balun. This is followed by a design example and simulations of the design.

A. Design procedure

The lumped element Marchand balun is chosen to realise the circuit [10]. This has the advantages of small size together with possibility to place capacitors where the added reactances X_{s_2} and X_m is needed. In figure 4 the schematic is shown. The design procedure follows what is described in [9], with modification to incorporate X_{s_2} and X_m . The design equations is given as

$$L_s = \frac{Z_{0_e} + Z_{0_o}}{2\omega} \quad (16)$$

$$k = \frac{Z_{0_e} - Z_{0_o}}{Z_{0_e} + Z_{0_o}} \quad (17)$$

$$C_c = \frac{1}{2\omega} \left(\frac{1}{Z_{0_o}} - \frac{1}{Z_{0_e}} \right) \quad (18)$$

$$C_s = \frac{1}{\omega Z_{0_e}} \quad (19)$$

$$C_{s_2} = C_s - \frac{1}{X_{s_2}\omega} \quad (20)$$

$$C_m = 2C_s - \frac{2}{\omega X_m}. \quad (21)$$

B. Design example

To test the theory a X-band Marchand balun with transformation of generator impedance of $Z_g = 50\Omega$ to a load impedance of $Z_L = 50 - j60\Omega$ at 10.5 GHz is designed. The load value is chosen as it corresponds to a typical mixer diode load, being capacitive.

The circuit is designed using a designkit from Innovations for High Performance Microelectronics (IHP) for their $0.25 \mu\text{m}$ SiGe:C BiCMOS process. The process has metal-insulator-metal (MIM) capacitors and five metal layers.

The size of the inductor has been the deciding factor in choosing $Z_{0_e} = 32.5\Omega$ giving inductor sizes of $L_s = 0.4nH$. In table I the design parameters for the balun are given, both the theoretical values as calculated and the compensated values as implemented. Especially the implementation of the coupled inductors gives problems due to the difficulties of realization of exact k and C_c , but this can be compensated by changing C_m , C_s , and C_{s_2} .

Figure 5 shows layout of the proposed implementation. The two sets of coupled inductors has a total size of $423 \mu\text{m} \times 194 \mu\text{m}$ and the suggested breakout has a dimension of $610 \mu\text{m} \times 930 \mu\text{m}$. The dimensions of the breakout could also be used in a real circuit to avoid undesired coupling.

C. Simulation Results

Electromagnetic simulations using Momentum in Agilent ADS has been used to verify the design implementation. Due to designkit limitations the capacitors is not part of the Momentum simulation, but models is included in an Agilent

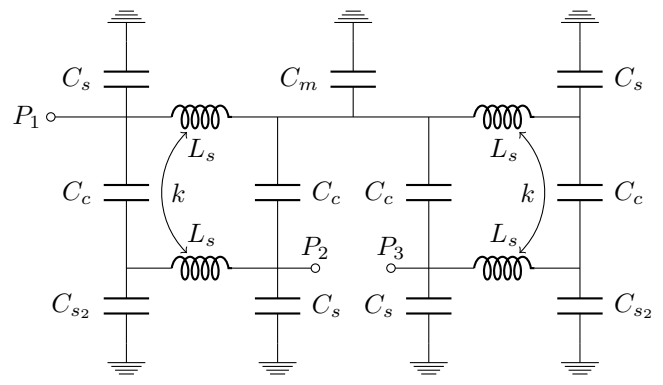

Fig. 4. The lumped element implementation of the Marchand balun with complex matching properties.

TABLE I
DESIGN PARAMETERS FOR THE BALUN

Description	Symbol	Calc.	Comp.
Even mode characteristic impedance	Z_{0_e} [Ω]	32.5	
Odd mode characteristic impedance	Z_{0_o} [Ω]	20.9	
Reactance, side	X_{s_2} [Ω]	-5.96	
Reactance, middle	X_m [Ω]	114	
Inductance	L_s [nH]	0.4	0.4
Inductive coupling	k	0.21	0.15
Capacitive coupling	C_c [fF]	129	157
Side capacitor	C_s [fF]	466	305
Increased side capacitor	C_{s_2} [pF]	3.01	2.6
Middle capacitor	C_m [fF]	667	727

ADS S-parameter simulation. The resulting S-parameters are plotted in Figure 6. At the design frequency, an insertion loss of 5.1 dB is simulated, together with a reflection of -20.8 dB. The phase imbalance is 0.2° and the magnitude imbalance is 0.12 dB. Figures 7 and 8 shows plots of the magnitude and phase difference from 8 to 14 GHz. The bandwidth is limited by the matching from 10.1 GHz to 10.8 GHz if a reflection below -15 dB is desired. In this band the insertion loss is better than 5.5 dB, the phase imbalance better than 0.3° , and the magnitude imbalance better than 0.16 dB.

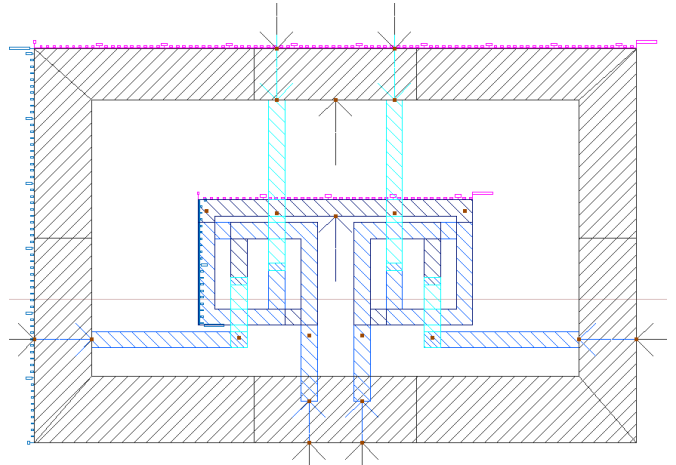

Fig. 5. Layout of proposed circuit, dimensions are $610 \mu\text{m} \times 930 \mu\text{m}$.

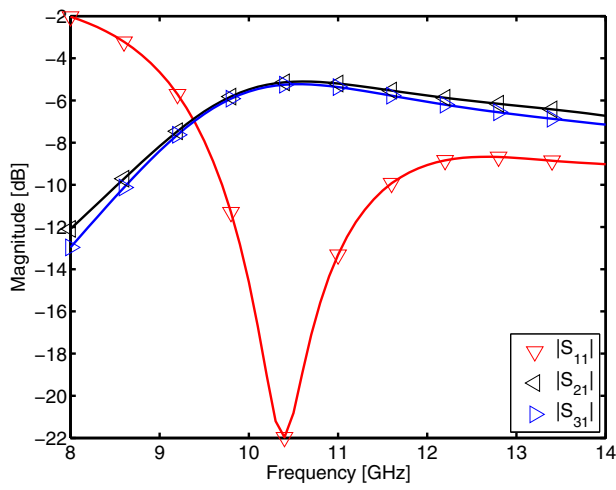

Fig. 6. Magnitude of S-parameters for the proposed balun circuit.

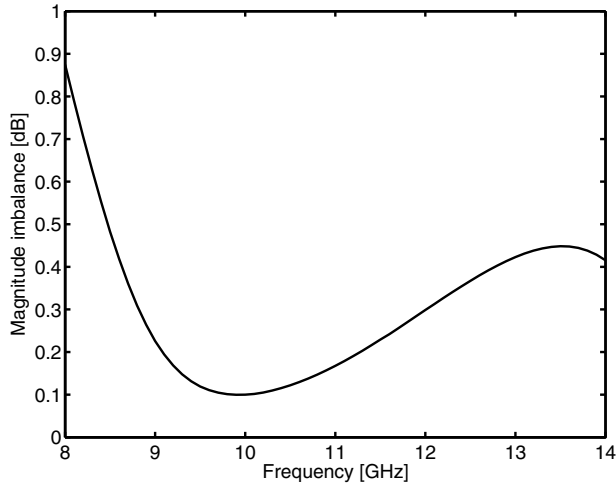

Fig. 7. Magnitude imbalance at the output for the proposed balun circuit.

IV. CONCLUSION

In this paper the novel idea of a complex impedance transforming Marchand balun was discussed. A detailed analysis gives the governing equations for realization of such a circuit. It was shown, that by addition of three reactances together with careful selection of even and odd mode characteristic impedance an arbitrary complex impedance match can be obtained.

A lumped element implementation of the complex impedance transforming Marchand balun was designed and EM-simulated. The lumped element implementation has the property of having capacitors placed where the additional reactances should be added anyway. Thus it is possible to absorb a positive reactance by reducing a capacitor and a negative by increasing a capacitor. With this design approach no additional inductances are needed for matching, thus reducing loss and circuit size.

The simulation showed that matching to a $50 - j66\Omega$ load

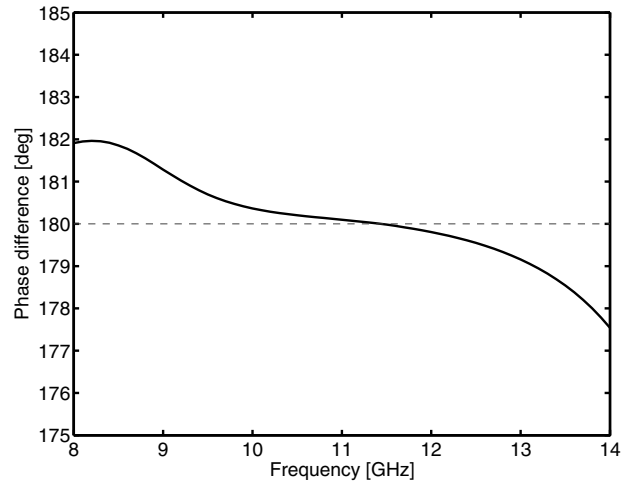

Fig. 8. Phase difference of the two output ports of the proposed balun circuit.

impedance was possible. An input reflection of -20.8 dB at the design frequency of 10.5 GHz, and a insertion loss of 5.1 dB was simulated. The phase and magnitude imbalance was better than 0.2° and 0.12 dB, respectively. The bandwidth is limited to the range from 10.1 GHz to 10.8 GHz for a input reflection better than -15 dB. In this band the insertion loss is better than 5.5 dB, the phase imbalance better than 0.2° , and the magnitude imbalance better than 0.16 dB.

REFERENCES

- [1] N. Marchand, "Transmission-line conversion transformers," *Electronics*, vol. 17, pp. 142–145, 1944.
- [2] J.-C. Lu, C.-C. Lin, and C.-Y. Chang, "Exact Synthesis and Implementation of New High-Order Wideband Marchand Baluns," *IEEE Transactions on Microwave Theory and Techniques*, vol. 59, no. 1, pp. 80–86, 2011.
- [3] L. Xu, H. Sjoland, M. Tormanen, T. Tired, T. Pan, and X. Bai, "A Miniaturized Marchand Balun in CMOS With Improved Balance for Millimeter-Wave Applications," *IEEE Microwave and Wireless Components Letters*, vol. 24, no. 1, 2014.
- [4] R. Michaelsen, T. Johansen, K. Tamborg, and V. Zhurbenko, "A Modified Marchand Balun Configuration With Tunable Phase Balance," *IEEE Microwave and Wireless Components Letters*, vol. 23, no. 2, pp. 66–68, 2013.
- [5] X. Miao, W. Zhang, Y. Geng, X. Chen, R. Ma, and J. Gao, "Design of Compact Frequency-Tuned Microstrip Balun," *IEEE Antennas and Wireless Propagation Letters*, vol. 9, pp. 686–688, 2010.
- [6] K. S. Ang, Y. C. Leong, and C. H. Lee, "Analysis and design of miniaturized lumped-distributed impedance-transforming baluns," *Microwave Theory and Techniques, IEEE Transactions on*, vol. 51, no. 3, pp. 1009–1017, mar 2003.
- [7] T. Jensen, V. Zhurbenko, V. Krozer, and P. Meincke, "Coupled Transmission Lines as Impedance Transformer," *IEEE Transactions on Microwave Theory and Techniques*, vol. 55, no. 12, pp. 2957–2965, 2007.
- [8] J. Reed and G. Wheeler, "A Method of Analysis of Symmetrical Four-Port Networks," *IRE Transactions on Microwave Theory and Techniques*, vol. 4, no. 4, pp. 246–252, 1956.
- [9] R. Michaelsen, T. Johansen, K. Tamborg, and V. Zhurbenko, "Design of a Broadband Passive X-Band Double Balanced Mixer in SiGe HBT technology," *To appear in International Journal of Microwave and Wireless Technologies*, 2014.
- [10] T. Johansen and V. Krozer, "Analysis and Design of Lumped Element Marchand Baluns," in *2008 MIKON CONFERENCE PROCEEDINGS*. IEEE, 2008, pp. 672–675.