

Journal Pre-proof

Effect of Premature Loading on Punching Resistance of Reinforced Concrete Flat Slabs

Ibrahim G. Shaaban, Ayman H. Hosni, Wael M. Montaser, Moataz M. El-Sayed

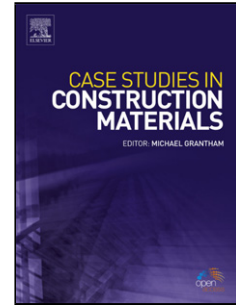

PII: S2214-5095(19)30422-X
DOI: <https://doi.org/10.1016/j.cscm.2019.e00320>
Reference: CSCM 320

To appear in: *Case Studies in Construction Materials*

Received Date: 28 August 2019
Revised Date: 25 November 2019
Accepted Date: 25 November 2019

Please cite this article as: { doi: <https://doi.org/>

This is a PDF file of an article that has undergone enhancements after acceptance, such as the addition of a cover page and metadata, and formatting for readability, but it is not yet the definitive version of record. This version will undergo additional copyediting, typesetting and review before it is published in its final form, but we are providing this version to give early visibility of the article. Please note that, during the production process, errors may be discovered which could affect the content, and all legal disclaimers that apply to the journal pertain.

© 2019 Published by Elsevier.

Effect of Premature Loading on Punching Resistance of Reinforced Concrete Flat Slabs

Ibrahim G. Shaaban¹ Ayman H. Hosni², Wael M. Montaser³, Moataz M. El-Sayed³

ibrahim.shaaban@uwl.ac.uk adec.egypt@gmail.com wmontaser@yahoo.com eng.moatazeltaher@gmail.com

¹ Civil Engineering and Built Environment, School of Computing and Engineering, University of West London, UK

² Structural Engineering Department, Faculty of Engineering, Ain Shams University, Egypt

³ Construction and Building Department, Faculty of Engineering - October 6 University

Highlights

- At 28 days, BS8110-97 and EC2 provide the most accurate predictions of punching shear capacity while ACI 318 (2014) and ECP-2018 equations seemed to be conservative for the studied specimens.
- Equations developed by BS8110 - 97 and EC2 did not predict punching shear experimental results accurately for the test slabs under premature loading (early age during construction).
- ACI 318 (2014) and ECP-2018 provided more reliable results for early loaded slabs when using the concrete compressive strength at the time of loading in prediction.
- It is highly recommended to use the actual compressive strength of concrete at early age (7 days for example) in calculating punching resistance of slabs in design phase.

Abstract

Premature loading of reinforced concrete flat slabs in multi storey buildings during construction may occur after shuttering removal and loading slabs earlier than usual to meet project time targets. Some case studies showed failure of flat slabs, which were prematurely loaded during the construction process before it reaches its full characteristic strength (at 28 days), which was used in structural design. This research aims to address this problem through experimental testing and design application according to current building codes. Eight specimens with dimensions of 1100 * 1100 mm and a total thickness of 120 mm were experimentally tested to study the effect of concrete age and actual compressive strength at loading on the punching shear capacity of reinforced concrete slabs. All specimens were supported by a square column with dimensions of 150 × 150 mm and loaded at the four corners with a span of 1050 mm. Accelerating admixture was used in three studied specimens to achieve higher concrete compressive strength at early ages compared to their companions of normal concrete without these admixtures. It was found that increasing concrete compressive strength of slab from 25 N/mm^2 to 35 N/mm^2 (40% increase) for normal concrete, without early admixture, improved punching shear capacity by 26%, while increasing it to 45 N/mm^2 (80% increase) improved punching shear capacity by 49% when the

specimens were loaded 7 days after casting. In addition, using an accelerating admixture increased early concrete compressive strength, which improved punching shear capacity of reinforced concrete slab over that without accelerating admixture by 31% and 29% after 7 days and 14 days, respectively. According to inclusion of reinforcement ratio, BS8110 - 97 and EC2 design codes showed the most accurate prediction of punching shear capacity at 28 days, while ACI and ECP seemed conservative as their equations do not take steel ratio into consideration. At early ages, BS8110 - 97 and EC2 design equations did not provide accurate prediction of punching shear capacity while ACI and ECP provided reliable equations. It is highly recommended to use the actual compressive strength of concrete at early age (7 days for example) for calculating punching shear resistance of flat slabs in multi storey buildings prior to shuttering removal to prevent any premature loading.

Keywords: flat slabs; immature concrete; punching shear; premature loading; failure; compressive strength

Notations

f_{cu} , characteristic cube concrete strength, MPa

α , Factor depends on the column location, $\alpha = 20$ for corner columns; 30 for edge columns; 40 for interior columns

d , Effective slab depth, mm

a, b , Column short and long direction, respectively.

v , Nominal shear stress.

LVDT, Linear Variable Displacement Transducer

f'_t , Cylindrical concrete tensile strength

SNCS, Normal concrete slab.

SECS, Early strength concrete slab

f'_c , Cylindrical concrete compressive strength

β_c , the column aspect ratio

u , the critical punching perimeter

ρ , the flexural steel ratio calculated for a width equal to $(c + 3d)$ or $(b + 3d)$, $\rho = (\rho_x + \rho_y)/2 < 0.03$; $400/d$ should not be taken as less than 1.

P_{exp} , experimental ultimate load

P_{cr} , cracking load of slabs

P_{pred} , predicted load

Δ_u , Maximum deflection of slabs

γ_c , Material Reduction Factor for Concrete = 1.50 in this research.

$\gamma_m = 1.25$

c_1 is the long side length of the column

c_2 is the short side length of the column

1. Introduction

The first use of reinforced-concrete flat slabs, supported solely on columns, dates back to the early twentieth century (Bartolac et al., 2015). Over the years, researchers reported that the significant parameters influencing the punching strength of slabs are primarily the compressive strength of

concrete, reinforcement ratio, size and geometry of columns, and effective depth of the slab (Einpaul et al, 2015; Muttoni et al., 2018). Muttoni (2008) developed a theoretical approach to slab punching, which is based on the critical shear crack theory. According to Muttoni's theory, punching shear strength of slabs depends on the slab rotation due to load, the position of the crack, the opening of the critical shear crack, and the roughness of the crack. Avoidance of brittle failure of slabs by punching shear can be achieved by various reinforcement systems in the form of inclined stirrups (Broms, 2019; Almeida, André, et al., 2019) and also in the form of shear studs (Torabian, Ala, et al, 2019; Ferreira, et al., 2019; Isufi, Brisid et al, 2019). In Eurocode-2 (2004), the punching shear strength is expressed as a function of the concrete cube compressive strength, $(f_{cu})^{1/3}$. On the other hand, ACI Code 318 (ACI 318 - 14) reported that the punching shear strength is a function of cylinder compressive strength ($\sqrt{f'_c}$) for concretes whose compressive strength does not exceed 69 MPa. In different building codes, the reinforcement ratio, defined as the ratio of the tensile reinforcement area to the effective area of the slab, is the parameter that significantly influences punching strength.

Premature loading of reinforced concrete flat slabs during construction generally occurs because of the efforts to meet project time targets (Ding et al., 2009). Hongyan, 2015, reported that the loads applied on the partially completed structure due to the construction process could be larger than the design service load. This construction load may exceed the design loads, which in turn, led to early failure of slabs. Wood (2003) reported that the available strength of the immature partially completed structure is dependent upon the concrete strength in those members, which may be less than the specified strength, and the failure would occur if the available strength were less than that required to support the construction loads. Premature failure of such slabs is generally associated with a concentration of high shear forces and bending moments at the column peripheries (Rizk et al., 2011). This type of failure is catastrophic because there are no external visible signs prior to the occurrence of the failure (ACI SP-232, 2005). When a slab is loaded prematurely, its serviceability is compromised (RILEM Committee 42-CEA, 1981). Therefore, it is necessary to investigate the effect of premature loading on reinforced concrete slabs to avoid cracking and possible failure (Hongyan, 2015). Hawkins et al., 1974; Gardner, 1990; Abdel Hafez, 2005; Wood, 2003; Sagaseta et al., 2014; Rankin and Long, 2019, reported that insufficient early-age punching shear capacity under relatively high construction loads is one of the common reasons of failure of flat slab structures during construction. They also reported that punching shear failure is caused by the failure of concrete in tension. Figure 1 shows real case studies for the collapse of a factory building (Vetogate, 2014) and a residential building (Elshorouk City Website, 2019) in Egypt as a result of premature loading of reinforced concrete flat slab. Sudden punching failure took place during the concrete casting process of second floor. The consultant reported that the low strength of concrete at the time of early removal of the first-floor formwork was the main reason for the building collapse.

The current investigation aims to study the effect of concrete age and the actual compressive strength at the time of premature loading during construction on the punching shear capacity of reinforced concrete slabs. Experimental testing of eight flat slab specimens was carried out in Concrete lab at Cairo University to gain a better understanding of the relation between the punching shear behaviour and the actual concrete compressive strength at the time of testing. In addition, the effect of using accelerating admixtures to achieve higher strength at early age of test specimens was studied experimentally and verified theoretically using the design equations of the international design Building codes. This may help structural designers of projects, which the time of construction is very tight.

2. Codes provisions for punching shear equations

The calculation of the punching shear capacity is outlined in different Design Codes as follows:

2.1 Eurocode-2 (2004)

The nominal shear stress definition in Eurocode-2 takes into account the effect of reinforcement ratio and size as follows:

$$v_{Rd,c} = C_{Rd,c} k(100\rho f_{cu})^{1/3} + k_1\sigma_{cp} \dots\dots\dots(1)$$

$$u = 2(c_1 + c_2 + 2\pi d) \dots\dots\dots(2)$$

$$k = 1 + \sqrt{\frac{200}{d}}, C_{Rd,c} = \frac{18}{\gamma_c} \text{ and } u \text{ is located at } 2d \text{ away from column face defined in Equation (2)}$$

2.2 British Standard BS 8110-97

The British Standards, BS 8110-97, use a rectangular control perimeter, $1.5d$, from the loaded area for both the circular and rectangular loaded areas. Although BS 8110-97 has been replaced in the UK by Euro code 2, its inclusion in this investigation is relevant, as it has been used as the basis for some other Building codes.

$$v = 0.29 (100\rho f_{cu})^{1/3} \left(\frac{400}{d}\right)^{1/4} \dots\dots\dots(3)$$

$$u = 2(c_1 + c_2 + 6d) \dots\dots\dots(4)$$

2.3 ACI -318 (2014)

ACI 318 - 14 defines the nominal shear stress, v , as the minimum of the following three expressions, which consider the effects of the rectangularity of the column, location of the connection, and ratio of the loading area to effective thickness on the nominal shear stress. It is worth mentioning that f_c' , can be calculated from f_{cu} according to the well-known relation between cylinder and cube strength as the strength of cylinder is taken as 0.8 times the strength of cube.

$$v = \text{minimum of } \begin{cases} 0.33 \sqrt{f_c'} \\ 0.083\sqrt{f_c'} \left(2 + \frac{4}{\beta_c}\right) \\ 0.083\sqrt{f_c'} \left(2 + \frac{\alpha d}{u}\right) \end{cases} \dots\dots\dots(5)$$

$$u = 2(c_1 + c_2 + 2d) \dots\dots\dots(6)$$

2.4 Egyptian code of practice (E.C.P.-2018)

According to the Egyptian code of practice, the critical section for punching shear is located at a distance of $(0.5d)$ from the column faces, where (d) is the effective slab depth. This code of practice does not account for the effect of the reinforcement ratio on the punching shear strength.

Additionally, no provisions have been introduced in this code of practice for the use of transverse reinforcement in flat slabs.

The ultimate punching shear strength for slab column connections is calculated as the minimum of the three values obtained from the following equations:

$$q = 0.80 \left(0.20 + \frac{\alpha d}{b_0} \right) \sqrt{\frac{f_{cu}}{\gamma_c}} \dots\dots\dots (7)$$

$$q = 0.316 \left(0.50 + \frac{a}{b} \right) \sqrt{\frac{f_{cu}}{\gamma_c}} \dots\dots\dots (8)$$

$$q = 0.316 \sqrt{\frac{f_{cu}}{\gamma_c}} \dots\dots\dots (9)$$

3. Experimental Program

3.1 Test Specimens

Eight reduced-scale slab specimens were tested at Cairo University Structural Engineering Laboratory. The size of specimens was 1100 mm by 1100mm with a uniform thickness of 120 mm. The reinforcement ratio was the same for all specimens ($\rho = 1.90\%$) using 12 mm diameter bars, and the effective depth (d) was 100 mm. Figures 2a and b show the specimen dimensions and reinforcement. The eight specimens were divided to three groups. The first group was cast specifically to test the effect of early (premature) loading by testing at different times of loading, after 7, 14, and 28 days. It was consisted of three specimens (SNC1-1, SNC1-2, SNC1-3) made with Ordinary Portland Cement (OPC) only (without accelerating admixture). Each of the specimens had a target concrete compressive strength of 35 MPa after 28 days, and they were tested after 7, 14, and 28 days. The second group was cast to test the effect of the attained concrete compressive strength at the age of 7 days. It was consisted of two specimens (SNC2-1, SNC2-2) made with OPC (no addition of accelerated admixtures) where (SNC2-1) had a target concrete compressive strength of 25 MPa after 28 days and (SNC2-2) had a target concrete compressive strength of 45 MPa after 28 days and they were tested at 7 days. The third group specimens were cast to test the effect of adding accelerating admixture to the concrete mix and this group consisted of three specimens (SESC3-1, SESC3-2, and SESC3-3) that allow concrete to gain higher strength at early age compared to their companions of normal concrete without accelerating admixtures. These specimens had a target concrete compressive strength of 35 MPa after 28 days, and they were tested after 3, 7, and 14 days respectively as shown in Table 1.

3.2 Material properties

Normal crushed dolomite stone was used for concrete mix with maximum aggregate size (d_g) of 10 mm, also natural sand as fine aggregates, OPC, and tap water. In addition, an accelerating admixture was used for producing higher early strength concrete. The mix proportions of the concrete is given in Table 1. Hot-rolled steel bars were used with a well-defined yield plateau and a strain-hardening branch. The yield strength of the reinforcement measured from tensile tests was 392 MPa. Three companion concrete cube samples were prepared from the same mixes as the slabs were measured at the time of testing and the average of results are shown in Table 2.

3.3 Instrumentation and test set-up

The specimens were loaded using hydraulic jacks of 500 KN capacity, manually operated by a pump. The LVDTs were used to measure the vertical deflection in the specimens at different load levels (see schematic diagram in Figure 2b). The specimens were placed in a horizontal position between the jack and a square rigid steel frame in simply supported conditions as shown in the schematic diagram and the photo in Figure 2(c). To achieve the simply supported condition in the laboratory, a bar of diameter 22 mm was welded to the top of the steel frame. The displacement was measured at five control points. The first control point was in the middle of the slab, at the center of the column to measure the maximum deflection. The other control points were located at a distance equal to one and half times the slab effective depth ($1.5d$). The strain gauges, LVDTs and load cells were connected to the data acquisition system. All the tests were force controlled. Test setup is shown in Figure 2c.

4. Experimental Results and Discussion

The experimental results (crack pattern, slab deflection and steel strain) obtained during the tests are discussed in the following sections. The load–deflection values were measured using five LVDTs placed on the tension surface of the studied slabs. The load-deflection relationships are shown in Figure 4 and the experimental results for cracking load, P_{cr} , ultimate load P_u , and maximum deflection, Δ_u , for studied slab are recorded in Table 3. Strain gauges attached to the bottom longitudinal bars (tension face) were used to measure the steel reinforcement strain during the testing process and connected to the data acquisition system. Figure 5 shows the load-tensile strain at column face for the studied specimens.

4.1 Crack Pattern

The failure mode of all tested specimens was brittle. Figure 3 shows the crack patterns for the specimens, which exhibited a typical punching shear-inclined cracking the vicinity of the column. For all experimentally tested specimens, the first crack was developed in the tension surface. Starting from the region underneath the loading area, the cracks propagated diagonally to the corners, and more cracks were developed in the tension surface. These cracks formed the classical punching critical zone. This is in agreement with Oliveira et al., 2004; Ozden et al., 2006; and Papanikolaou et al., 2005 who observed similar crack pattern in their studied specimens.

4.2 Effect of Premature Loading (Group 1 specimens)

The effect of early age (premature) loading on the punching shear capacity was clear from the results of Group 1 specimens in Figures 4-5 and Tables 2-4. Figure 4(a) shows the load-deformation behavior of the tested specimens. Time of loading had a significant effect on the deformation of the specimens because their concrete compressive strength changed over time, and the deflection at the maximum load ranged from 5.75 mm to 8.75, as shown in Figure 4(a). It can be observed from Table 3 and Figure 4a that SNC1-3 (tested after 7 days) was able to reach only 57% of the punching shear capacity of SNC1-1 (tested at 28 days), whereas SNC1-2 (tested after 14 days) was able to reach approximately 70% of the punching shear capacity of SNC1-1 (tested at 28 days). It was observed that the punching shear capacity was affected by the time of loading as some of cube strengths of this group did not achieve the target compressive strength as shown in Table 2. These results indicate also that the development of punching shear capacity was slower than the development rate of increase in the concrete compressive strength. In addition, SNC1-3 had a higher deflection value because it had the lowest concrete compressive strength (tested after 7 days).

Figure 5(a) shows the load-steel strain behavior of the specimens. It was noticed that brittle failure of the concrete occurred first, and all the specimens experienced punching shear failure before the steel yielded. None of the flexural steel reached the yield stress, as the brittle failure of concrete occurred first, and the maximum recorded steel strain occurred in specimen SNC1-1, which was tested after 28 days, as shown in Figure 5(a). At the same load, Specimen SNC1-3 had a higher steel strain than those of the other specimens since Specimen SNC1-3 was cracked before the other specimens. This may be attributed to the fact that the tensile stress occurred in concrete exceeded its tensile strength.

4.3 Effect of Concrete Compressive Strength (Group 2 specimens)

The load-deformation behavior of the Group 2 specimens is shown in Figure 4(b). It can be seen from the figure that increasing the target concrete compressive strength by 40% led to an increase in the punching shear capacity by 26% and increasing the target concrete compressive strength by 80% resulted in enhancing the punching shear capacity by only 49%. The concrete compressive strength had a significant effect on the deformation of slabs, as punching failure is caused by the failure of concrete in tension, and the tensile strength of concrete varies between 8% and 15% of the compressive strength. The ultimate punching load ranged from 154 KN for SNC2-1 to 230 KN for SNC2-2, whereas the deflection at maximum load ranged from 4.69 mm to 6.2 mm, as shown in Figure 4(b). In addition, Specimen SNC2-1 had a higher deflection compared to that of the other groups because it had the lowest concrete compressive strength compared to that of the other groups as shown in Figure 4b. None of the flexural steel reached the yield stress, as the brittle failure of concrete occurred first, and the maximum steel strain occurred in Specimen SNC2-2 as shown in Figure 5(b).

4.4 Effect of Accelerating Admixture (Group 3 specimens)

The accelerating admixture used in the Group 3 mix increased the early concrete compressive strength compared to that of normal concrete without accelerating admixture, and in turn, enhanced the punching shear capacity under premature loading tests. This effect is clearly observed in Tables 2-3 and Figure 4c for Group 3 specimens. The punching shear capacity was affected by the time of loading, even for the specimens with accelerating admixture, but the punching shear capacity was improved compared to that of their companions without accelerating admixture at the same time of loading. Figure 4c shows the load-deformation behavior of the Group 3 specimens. It can be seen from the figure that the deflection at maximum load ranged from 6.22 mm to 7.85 mm. In addition, Specimens S3-3 had a higher deflection compared to that of its companion from the other groups because it had the lowest concrete compressive strength compared to those of the other group specimens as shown in Figure 4c. Figure 5(c) shows the load-steel strain behavior of the tested specimens. It was found also that none of the flexural steel reached the yield stress.

5. Comparison between Experimental Results and Code Provisions

The experimental results were compared with the theoretical values predicted by the ACI 318 (2014), ECP-2018, EC2, and BS 8110-97 equations above in Section 2 to understand their applicability to concrete specimens at different ages. In the analytical evaluations, all the safety coefficients were assumed equal to one and the average experimental values were considered for the strength analysis. The predicted values according to the above-mentioned codes were recorded in Table 4. It was found that, at 28 days, BS8110-97 and EC2 provided the most accurate predictions where the punching shear capacity is proportional to the cubic root of the concrete

strength. On the other hand, ACI 318 (2014) and ECP-2018 equations seemed to be conservative for the studied specimens at 28 days where the square root of the concrete strength controls the punching shear capacity. On the contrary, Ala Torabian et al., 2019; Guandalini et al., 2009, showed that ACI 318 (2014) equations may be not conservative for low reinforcement ratios. It can be argued that the reinforcement ratio used in the current investigation was adequate according to ACI 318 (2014) and ECP-2018 codes provisions. At early ages (less than 28 days), the BS8110-97 and EC2 equations did not predict punching shear values for studied slabs accurately while ACI 318 (2014) and ECP-2018 equations seemed to be conservative and their results were lower than the experimental results. At this point we can say that ACI 318 (2014) and ECP-2018 equations can be considered acceptable in predicting shear capacity of flat slabs, when the premature loading is applied during construction before the concrete gain its full strength. However, actual concrete compressive strength at the time of loading has to be taken into account in prediction as shown in Table 4.

6. Conclusions

This paper presents an experimental investigation undertaken to evaluate the punching shear behaviour of concrete slabs. Eight reduced scale slab specimens were cast and tested until failure by punching. The experimental results were analysed and compared with codes provisions. The following conclusions can be drawn from this study as follows:

- 1- It was found that the rate of increase of punching shear capacity with time is slower than that of concrete compressive strength for the same studied slabs. For example, punching shear capacity of normal concrete slab tested after 7 days and 14 days reached approximately to 57% and 70% of their companions after 28 days while its concrete compressive strength at the same periods reached 69% and 80% of that of their companions after 28 days.
- 2- Increasing concrete compressive strength of slab from 25 N/mm^2 to 35 N/mm^2 (40%) led to an improvement in punching shear capacity by 26%, while increasing it to 45 N/mm^2 (80%) improved punching shear capacity by 49% after 7 days.
- 3- Punching shear capacity of concrete slabs made with accelerating admixture tested after 3 days and 7 days reached approximately to 58% and 82% of their 14 days strength while their compressive strength reached 66% and 88% of their compressive strength after 14 days. Slab specimens made with accelerating admixture had punching shear capacities higher than that of their companions of normal specimens without accelerating admixtures by 31% and 29% after 7 days and 14 days, respectively.
- 4- It was found that, at 28 days, BS8110-97 and EC2 provided the most accurate predictions while ACI 318 (2014) and ECP-2018 equations seemed to be conservative for the studied specimens.
- 5- Equations developed by BS8110 - 97 and EC2 did not predict punching shear experimental results accurately for the test slabs under premature loading while ACI 318 (2014) and ECP-2018 provided more reliable results for early loaded slabs when using the concrete compressive strength at the time of loading in prediction. Therefore, it is highly recommended to use the actual compressive strength of concrete at early age (7 days for example) in calculating punching resistance of slabs in design phase.

Conflict of interest

This is to declare that all the authors have no conflict of interest.

Journal Pre-proof

References

- Abdel Hafez, A. M., 2005, "Punching shear behavior of normal and high-strength concrete slabs under static loading", Ukraine, *Journal of Engineering Sciences*, Vol. 33, No. 4, pp. 1215-1235.
- ACI SP-232, 2005, "Punching shear in reinforced concrete slabs", Farmington Hills, MI: American Concrete Institute, Polak, M.A. (Ed), 302 pp.
- ACI Committee 318-14 "Building Code Requirements for Structural Concrete (ACI 318- 14) and Commentary (318R-14)," Farmington Hills, American Concrete Institute.
- Almeida, André, et al., 2019, "Behaviour of reinforced- concrete flat slabs with stirrups under reversed horizontal cyclic loading." *Magazine of Concrete Research*, ahead of print, <https://doi.org/10.1680/jmacr.18.00209>.
- Bartolac, M., Damjanović, D., and Duvnjak, I., 2015, "Punching strength of flat slabs with and without shear reinforcement", *GRAĐEVINAR*, Vol. 67, No. 8, pp. 771-786.
- British Standards Institution. BS 8110 (1997) Part 1: structural use of concrete: code of practice for design and construction. London: BSI.
- Broms, Carl Erik., 2019, "Cages of Inclined Stirrups as Shear Reinforcement for Ductility of Flat Slabs", *ACI Structural Journal*, Vol. 116, No. 1, pp. 83-92
- Ding, H.Y., Liu, H. X., and Hou, C., 2009, "Analysis of construction technology for early dismantlement of floor formwork under the least favorable conditions," *Journal of Natural Disasters*, Vol.18, No. 4, pp. 49–54.
- Elshorouk City Website, 2019, "Photos for domestic and business buildings as a result of premature punching failure of its reinforced concrete flat slab", published in August in social media.
- Einpaul J, Fernández Ruiz M, Muttoni A. (2015), "Influence of moment redistribution and compressive membrane action on punching strength of flat slabs", *Engineering Structures*, Vol. 86, pp. 43-57.
- European Committee for standardization. (2004) EN 1992-1-1 Eurocode 2: design of concrete structures – Part 1-1: general rules and rules for buildings, European Committee.
- Ferreira, M, Oliveira, M.H., and Melo, G. S., 2019, "Tests on the punching resistance of flat slabs with unbalanced moments", *Engineering Structures*, Vol. 196: 109311, <https://doi.org/10.1016/j.engstruct.2019.109311>
- Gardner, N. J., 1990, "Relationship of the punching shear capacity of reinforced concrete slabs with concrete strength", Naples, FL, 34105, *ACI Structural Journal*, Vol. 87, No. 5, pp. 66–71.
- Guandalini, S., Burdet, O.L., and Muttoni, A., 2009, "Punching tests of slabs with low reinforcement ratios", *ACI Structural Journal*, Vol. 106, No. 1, pp. 87- 95.
- Hawkins, N.M., Criswell, M.E., Roll. F., 1974, "Shear strength of slabs without shear reinforcement", Naples, FL, 34105, *ACI Publications Shear Reinforced Concrete.*, Vol. 42, No. 30, pp. 677–720.

- Hongyan, D., Lei Zhang, Puyang Zhang, 2015, "Experimental Study to Determine the Failure Criteria of Concrete at Its Early-Age", *Advances in Materials Science and Engineering*, Vol. 10, pp. 20-33.
- Isufi, B., Ramos, A.M., Lúcio, V. J., 2019, "Reversed horizontal cyclic loading tests of flat slab specimens with studs as shear reinforcement", *Structural Concrete*, Vol. 20, No. 1, pp. 330- 347, DOI: [10.1002/suco.201800128](https://doi.org/10.1002/suco.201800128)
- Muttoni A., 2008, "Punching shear of reinforced concrete slabs without transverse reinforcement", Naples, FL, 34105, *ACI Structural Journal*, Vol. 105, No. 4, pp. 440–450.
- Muttoni A., Fernández Ruiz M, João T. Simões, 2018, "The theoretical principles of the critical shear crack theory for punching shear failures and derivation of consistent closed-form design expressions", *International Federation for Structural Concrete Wiley online library.com/journal/suco Structural Concrete*, pp. 174–190.
- Oliveira, D.R.C, Regan, P.E., Melo, G.S.S.A., 2004, "Punching resistance of RC slabs with rectangular columns", Victoria 3010, Australia, *Magazine of Concrete Research*, Vol. 56, No. 3, pp. 123–138.
- Ozden S, Ersoy U, Ozturan T., 2006, "Punching shear tests of normal and high strength concrete flat plates", *Canadian Journal for Civil Engineering*, 2006, Vol. 33, No. 11, pp. 1389–1400.
- Papanikolaou, K.V., Tegos, I.A., Kappos, A.J., 2005, "Punching shear testing of reinforced concrete slabs and design implications", Victoria 3010, Australia, *Magazine of Concrete Research*, Vol. 57, No. 3, pp. 167–177.
- Rankin, G.I.B. and Long, A.E., 2019, "Punching strength of conventional slab-column specimens. *Engineering Structures*", Vol. 178, pp. 37-54. <https://doi.org/10.1016/j.engstruct.2018.10.014>
- RILEM Committee 42-CEA, 1981, "Properties of Set Concrete at Early Ages: State-of-the-Art Report," *Materials and Structures*, Vol. 14, No. 84, pp. 399-451.
- Rizk, E., Marzouk, H., Hussein, A., 2011, "Punching shear of thick plates with and without shear reinforcement", Naples, FL, 34105, *ACI Structural Journal*, Vol. 108, S55, pp. 581–591.
- Sagaseta, J, Tassinari, L., Fernández Ruiz, M., Muttoni, A., 2014, "Punching of flat slabs supported on rectangular columns", *Engineering Structures*, Vol. 77, pp. 17-33. <http://dx.doi.org/10.1016/j.engstruct.2014.07.007>
- Torabian, Ala, Isufi, B., Mostofinejad, D., Ramos, A.P., 2019, "Behavior of thin lightly reinforced flat slabs under concentric loading", *Engineering Structures* Vol. 196: 109327. <https://doi.org/10.1016/j.engstruct.2019.109327>
- Vetogate, 2014 "Failure of a factory for clothes in Obour City", <https://www.vetogate.com/1225273?fbclid=IwAR318oEP2vEHzf6pIZdQP1I1PrTnRa6WtkBktmPiptiPsXWJtFQ3weOtDWY>
- Wood, J. G. M., 2003, "Pipers row car park, Wolverhampton -Quantitative study of the causes of the partial collapse on 20th March 1997", Northbridge House, Chiddingfold, UK *Structural Studies & Design Ltd.*, p. 114.



(a) Collapse of a factory, Elobour city, Cairo (Vetogate, 2014)



(b) Collapse of residential building in Elshourok city, Cairo (Elshorouk City Website, 2019)

Figure 1 Recent collapses according to early punching of slabs

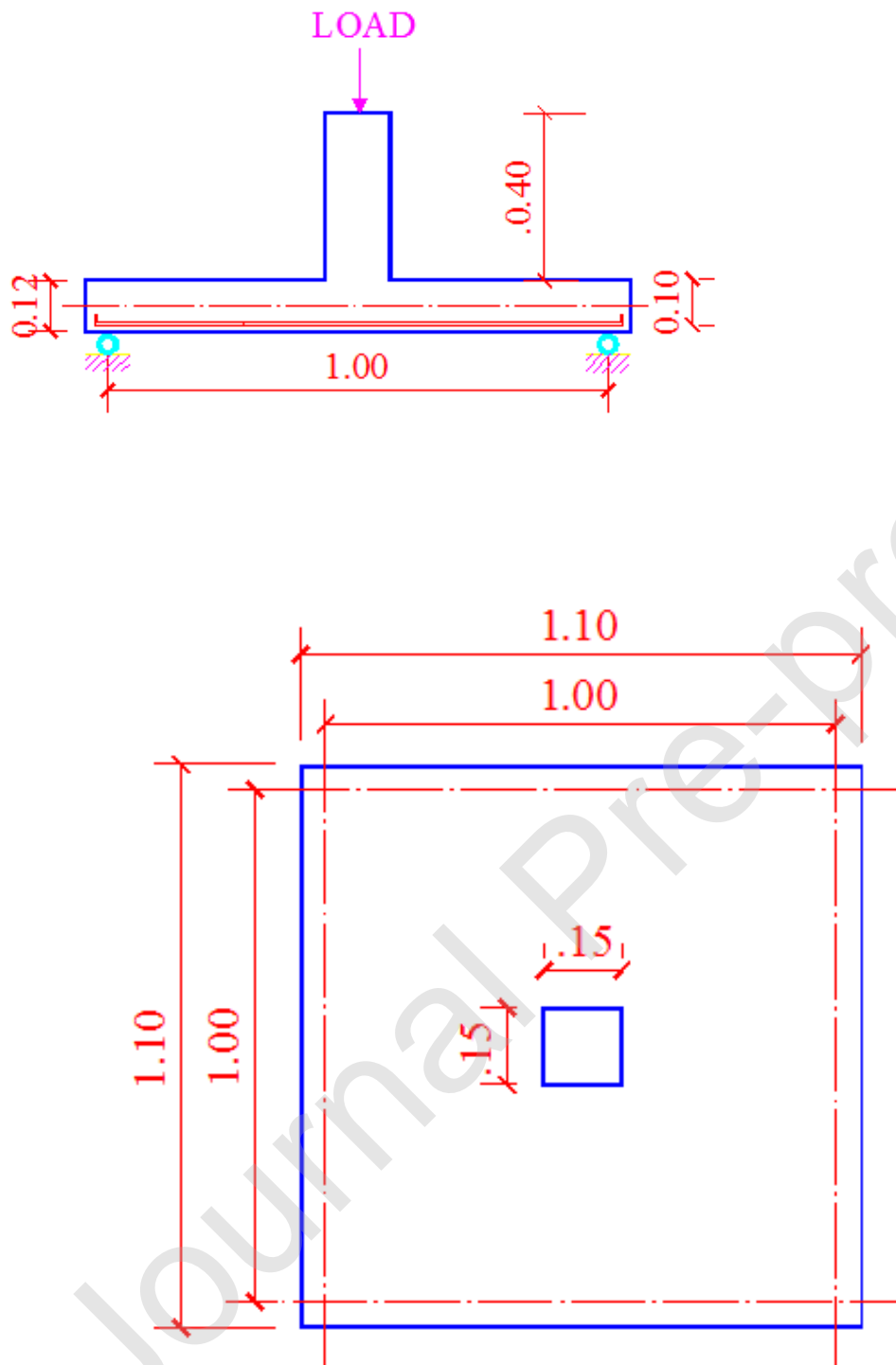

(a) Specimen dimensions

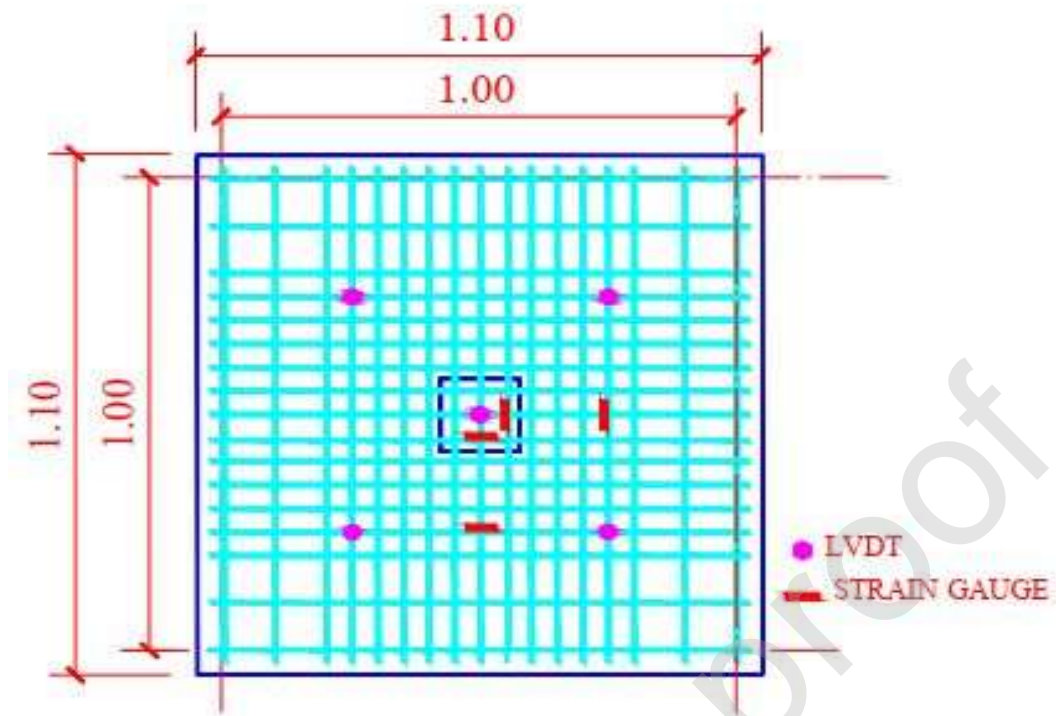

(b) Positions of LVDTs, strain gauges, and reinforcement details

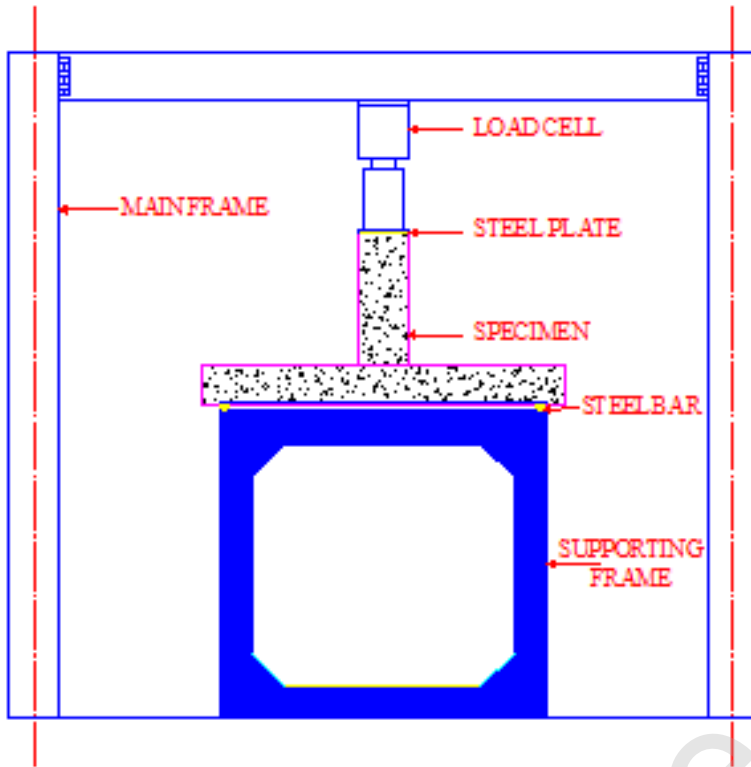

(c) Test setup

Figure 2 Details and testing of studied specimens



SNC (1-1)



SNC (1-2)



SNC (1-3)



SNC (2-1)

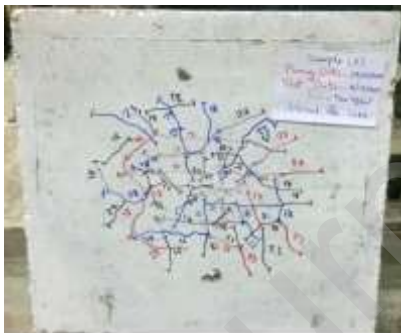

SNC (2-2)



SESC (3-1)



SESC (3-2)

SESC (3-3)

Figure 3 Crack pattern for specimens

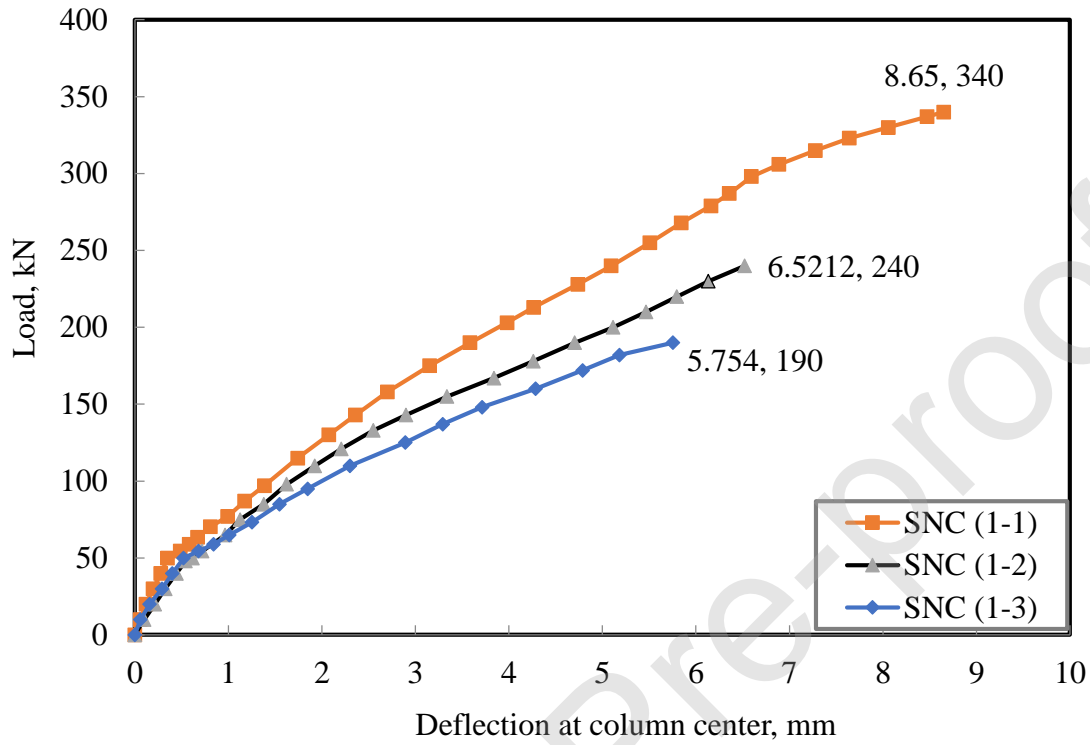

(a)

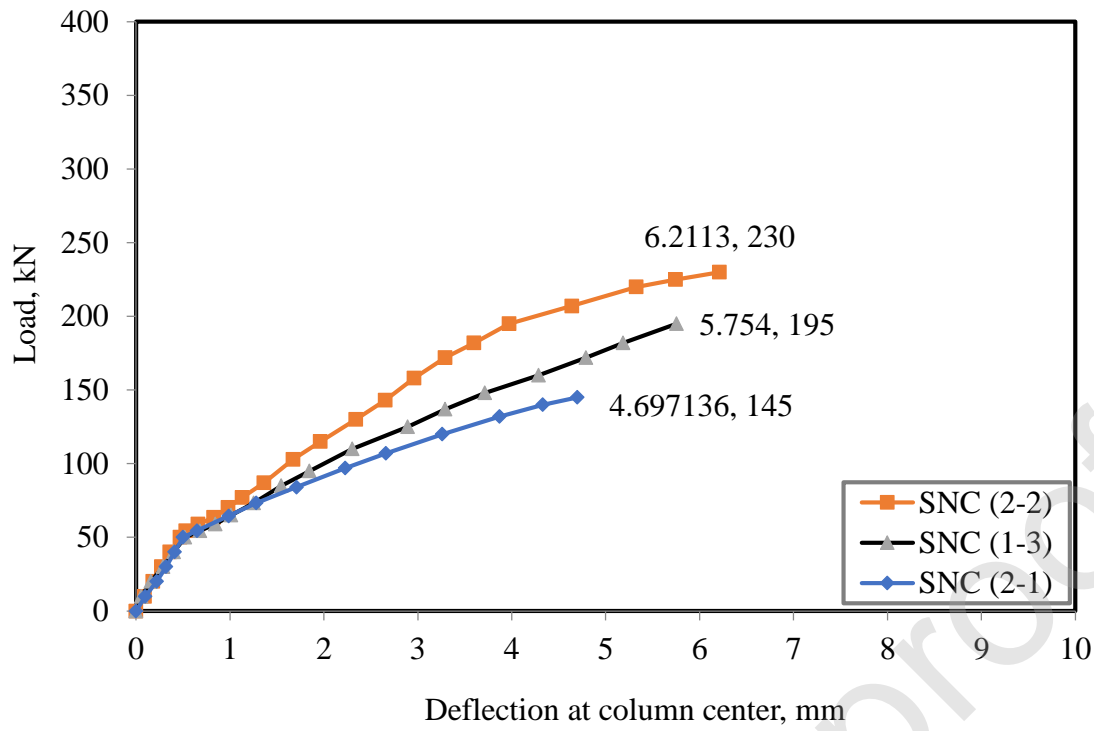

(b)

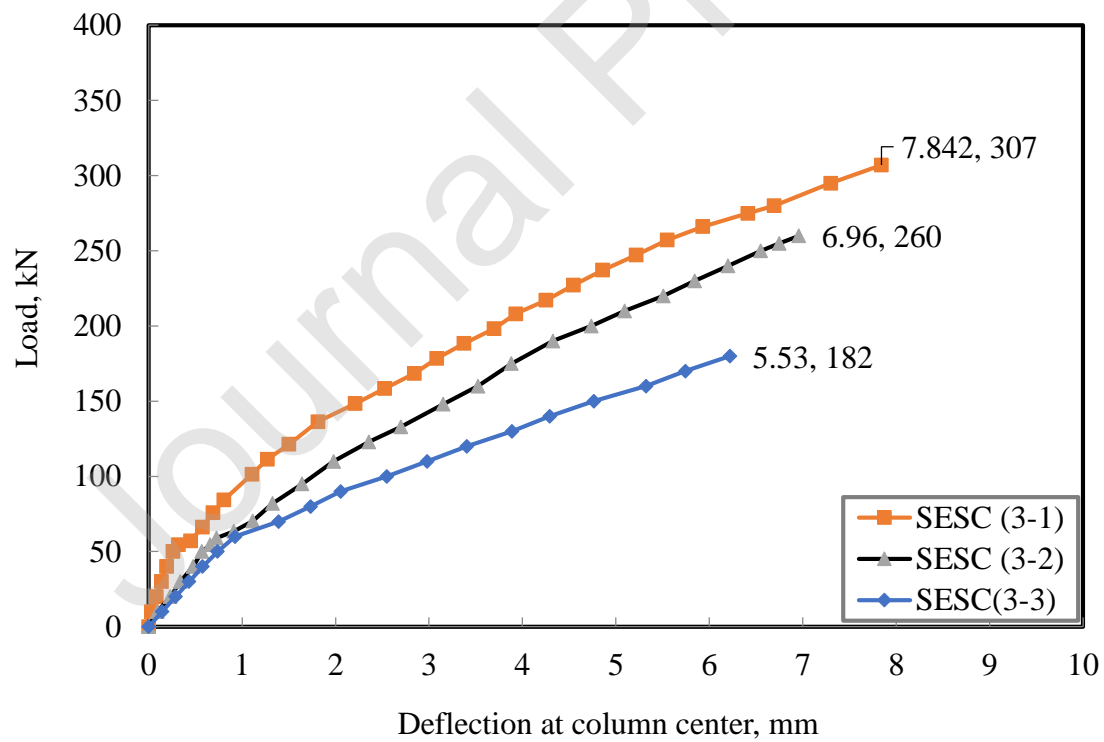

(c)

Figure 4 Deflection comparisons between three groups of specimens.

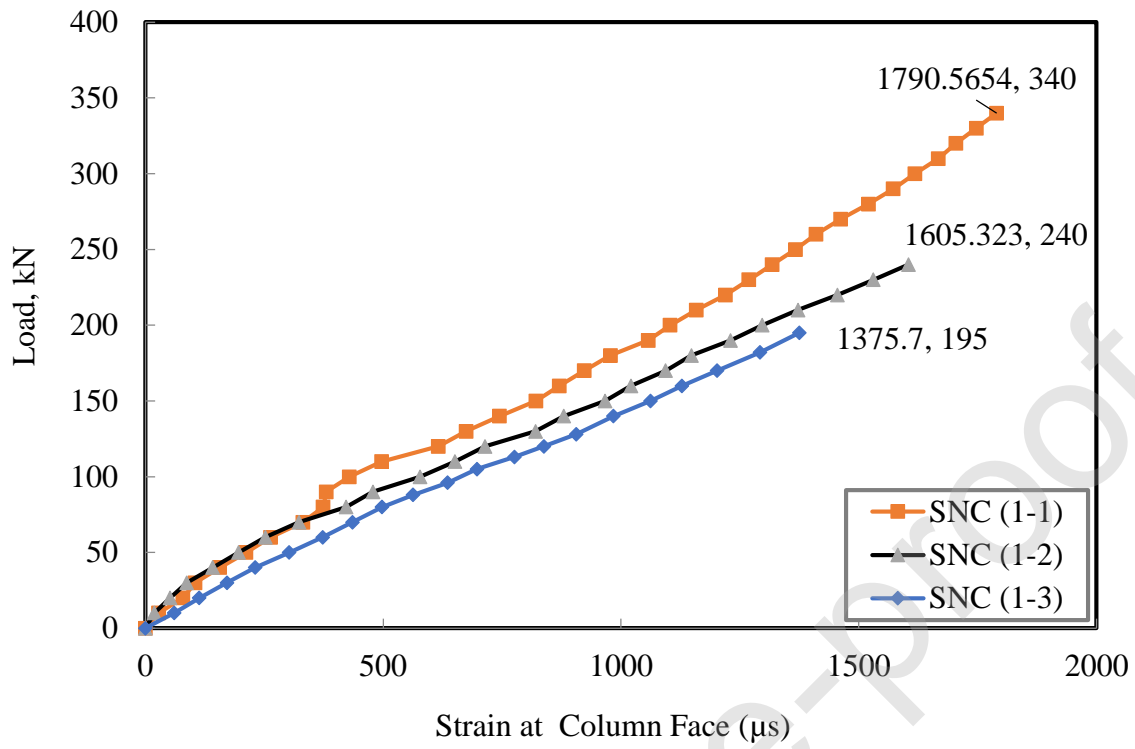

(a)

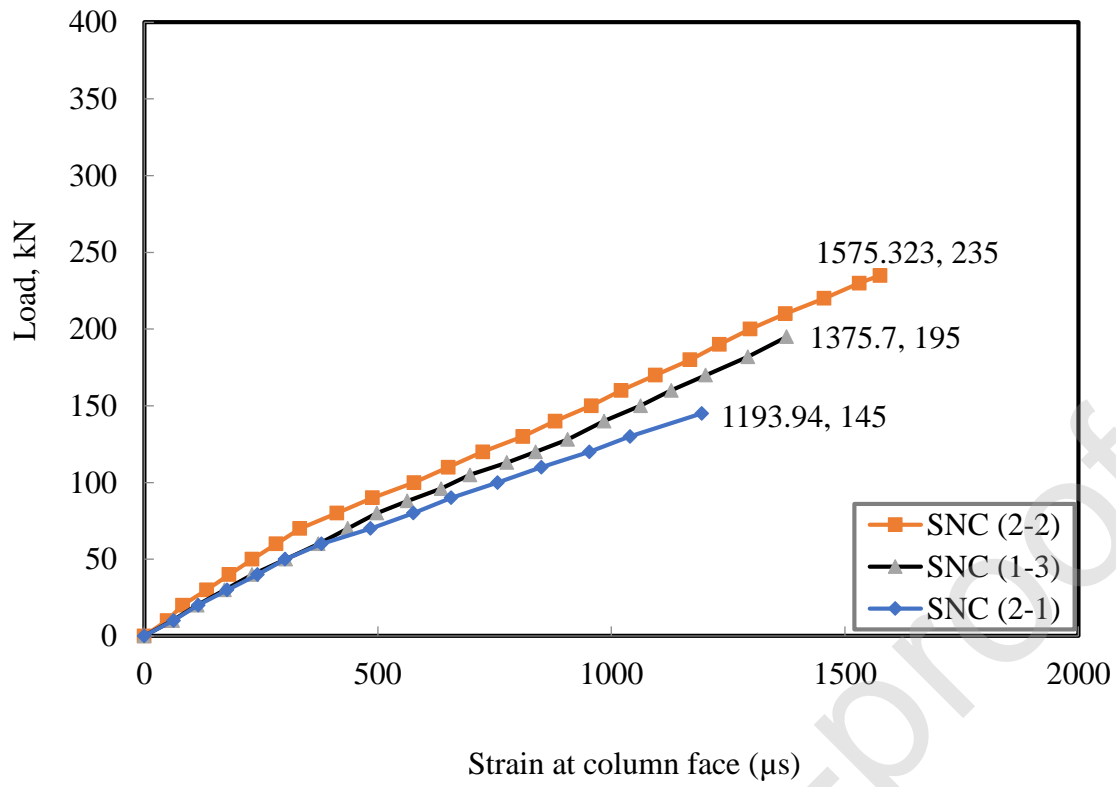

(b)

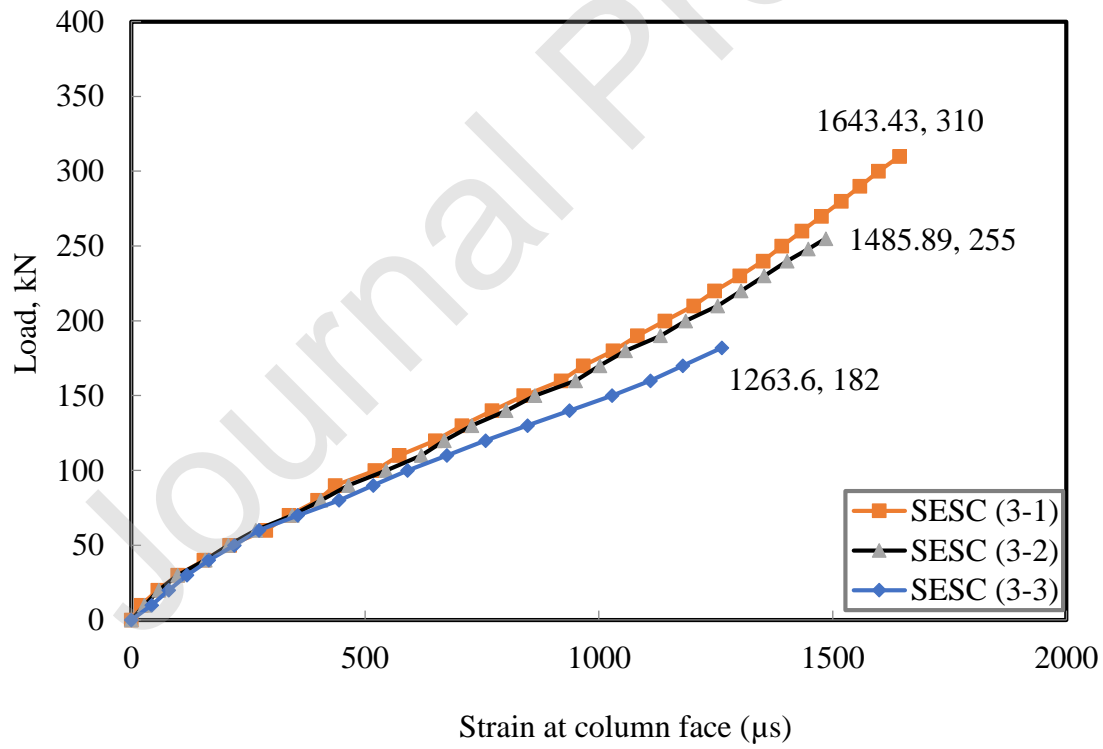

(c)

Figure 5 Steel strain comparisons between the three groups of specimens.

Journal Pre-proof

Table 1 Concrete mixture proportions

Material	Mix (1)	Mix (2)	Mix (3)	Mix (4)
Target compressive strength after 28 days	25 MPa	35 MPa	35 MPa	45 MPa
Cement	280	375	375	470
Sand	715	600	600	565
Crushed stone	1250	1200	1200	1130
Water (w/c)	170 (0.6)	200 (0.54)	200 (0.54)	245 (0.52)
Accelerating Admixture	-	-	6	-
Group/Sample designation	Group 2 SNC2-1	Group 1 SNC1-1 SNC1-2 SNC1-3	Group 3 SESC3-1 SESC3-2 SESC3-3	Group 2 SNC2-2
Testing age (days)	7	7, 14, 28	3, 7, 14	7

Table 2 Summary of test specimens and average results of three cubes and cylinders

Specimens	Target, f_{cu} (MPa)	Test Age (days)	Average f_{cu} (MPa)	Average f_t (MPa)	Remarks
SNC (1-1)	35	28	35.5	3.25	Control
SNC (1-2)	35	14	28.3	2.43	-
SNC (1-3)	35	7	24.6	2.21	-
SNC (2-1)	25	7	17.2	1.65	-
SNC (2-2)	45	7	31.3	2.82	-
SESC (3-1)	35	14	34.4	3.14	Accelerating admixture
SESC (3-2)	35	7	30.7	2.76	
SESC (3-3)	35	3	22.8	2.1	

Table 3 Summary of cracking and failure loads of specimens

Specimens	Loading Time (days)	P_{cr} (KN)	$P_{exp.}$ (KN)	Δ_u (mm)	Remarks
SNC (1-1)	28	80	340	8.65	Control
SNC (1-2)	14	70	240	6.52	-
SNC (1-3)	7	60	195	5.74	-
SNC (2-1)	7	45	154	4.69	-
SNC (2-2)	7	70	230	6.22	-
SESC (3-1)	14	80	310	7.82	Accelerating Admixture
SESC (3-2)	7	75	255	6.96	
SESC (3-3)	3	55	182	5.53	

Table 4 Comparison of experimental and predicted failure loads

Specimens	Loading Time (days)	Average f_{cu} (MPa)	$P_{exp.}$ (KN)	$P_{pred.}$ (KN)				$P_{exp}/P_{pred.}$			
				EC P	ACI	EC2	BS	ECP	ACI	EC2	BS
SNC (1-1)	28	35.5	340	188	177	310	279	1.8	1.92	1.09	1.21
SNC (1-2)	14	28.3	240	168	157	288	260	1.43	1.52	0.83	0.92
SNC (1-3)	7	24.6	195	156	143	265	249	1.25	1.36	0.73	0.78
SNC (2-1)	7	17.2	154	131	125	211	253	1.18	1.23	0.73	0.60
SNC (2-2)	7	31.3	230	177	165	295	279	1.3	1.4	0.79	0.84
SESC (3-1)	14	34.4	310	185	175	303	278	1.67	1.77	1.02	1.12
SESC (3-2)	7	30.7	255	175	161	288	264	1.45	1.57	0.88	0.96
SESC (3-3)	3	22.8	182	150	130	252	255	1.21	1.4	0.72	0.71