



Open Research Online

The Open University's repository of research publications and other research outputs

Lunar Volatiles Mobile Instrumentation (LUVMI) Project Results

Conference or Workshop Item

How to cite:

Garcet, Jeremi; Urbina, Diego; Sheridan, Simon; Biswas, Janos; Evagora, Anthony; Richter, Luiz; Fau, Guillaume; Kumar, Hemanth; Fodorcan, Daniel; Chupin, Thibaud; Kullack, Kasrten; Pitcher, Craig; Murray, Neil; Reiss, Philipp; Reganaz, Mattia; Govindaraj, Shashank; Aked, Richard and Salini, Joseph (2019). Lunar Volatiles Mobile Instrumentation (LUVMI) Project Results. In: 70th International Astronautical Congress (IAC), 21-25 Oct 2019, Washington DC / USA.

For guidance on citations see [FAQs](#).

© 2019 International Astronautical Federation (IAF)

Version: Version of Record

Copyright and Moral Rights for the articles on this site are retained by the individual authors and/or other copyright owners. For more information on Open Research Online's data [policy](#) on reuse of materials please consult the policies page.

oro.open.ac.uk

Lunar Volatiles Mobile Instrumentation (LUVMI) Project Results

Jeremi Gancet^a, Diego Urbina^a, Simon Sheridan^b, Janos Biswas^c, Anthony Evagora^d, Lutz Richter^e, Guillaume Fau^a, Hemanth Kumar^a, Daniel Fodorcan^a, Thibaud Chupin^a, Karsten Kullack^a, Craig Pitcher^b, Neil Murray^d, Philipp Reiss^c, Mattia Reganaz^e, Shashank Govindaraj^a, Richard Aked^a, Joseph Salini^f

^a *Space Applications Services, Leuvensesteenweg 325, 1932 Sint-Stevens-Woluwe, Belgium, jeremi.gancet@spaceapplications.com*

^b *The Open University, MK7 6AA, Milton Keynes, UK, simon.sheridan@open.ac.uk*

^c *Technical University of Munich, Institute of Astronautics, Boltzmannstraße 15, 85748 Garching, Germany j.biswas@tum.de*

^d *Dynamic Imaging Analytics, Milton Keynes Business Centre, Foxhunter Drive, Linford Wood, MK14 6GD, UK neil.murray@dynamicimaginganalytics.co.uk*

^e *OHB System AG, Manfred-Fuchs-Straße 1, 82234 Weßling, Germany, lutz.richter@ohb.de*

^f *Sony Semiconductor Solutions (Shanghai) Limited, China, josephsalini@gmail.com*

Abstract

LUVMI is an innovative, low mass, mobile robotic payload designed specifically for operations at the South Pole of the Moon with a range of several kilometres.

Over the 2 past years of the project, the key LUVMI scientific instruments (volatiles analyser and volatiles sampler) were successfully developed and validated up to TRL 5-6. In addition, a ground prototype of the LUVMI rover was developed and tested in a series of outdoor trials, in rocky and sandy environments. This rover, with a target dry mass of ~40kg for a flight version, features an adjustable height chassis to adapt to terrain roughness and allowing to bring instruments very closely and precisely to the surface. The locomotion capability of the LUVMI rover was tested in partially representative conditions, as part of the project.

This paper reports on the project's results and lessons learnt, and gives indications of how LUVMI may be further matured to target potential mission slots in the mid-2020s, as part of ESA mission and/or supported by private funding.

Keywords: lunar exploration, rover, volatiles, permanently shadowed regions

1. Introduction – Motivation and Mission Drivers

Believed to exist in or near the cold permanently shadowed regions (PSR) at the lunar poles, the possibility of water ice on the surface of the Moon is an item of intense scientific interest. The reasons for this are (1) the implications on the scientific study of volatiles more widely within our solar system and (2) its possible application as an in-situ resource for future exploration efforts.

A number of orbital probes, such as Clementine [5], Lunar Prospector [3], Cassini [1], Deep Impact [7], Chandrayaan-1 [6], Lunar Reconnaissance Orbiter [4], and LCROSS [2] brought evidences of the existence of lunar water using neutron spectroscopy, visual, infrared and ultraviolet spectroscopy, and radiometry. However the interpretation of these results

remain ambiguous and to this date, no in-situ measurements for verification has ever been performed.

The International Space Exploration Coordination Group (ISECG) identifies one of the first exploration steps as in situ investigations of the Moon or asteroids. Europe is developing payload concepts for drilling and sample analysis, a contribution to a 250kg rover as well as for sample return. To achieve these missions, ESA depends on international partnerships. Such missions will be seldom, expensive and the drill/sample site selected will be based on observations from orbit not calibrated with ground truth data.

By making use of an innovative, low mass, mobile robotic payload following the LEAG recommendations, many of the international science community's objectives can be met at lower cost. This is what LUVMI is aiming at.

In this paper we present the results achieved during the LUVMI project and follow-up activities. In the next sections, an overview of the rationales for a LUVMI mission are provided, and the LUVMI system is introduced. We then further detail the tests performed with the LUVMI payloads and rover platform, and finally highlight the follow-up activities and future perspectives.

2. Overview of the LUVMI system

2.1 Rover platform

The mechanical structure of the LUVMI rover is essentially made of aluminium frames, sandwich metal plates and 3D printed parts. The rover is based on a four wheels drive train and is capable of driving on slopes of up to 20 degrees (validated under 1g) while carrying payload mass of up to 30kg. The four wheels are independently steerable, which allows executing complex driving patterns.

In its operational configuration, the rover measures 1.4m x 0.9m x 0.5m (length, width, height - without masts), and weights approximately 60kg (including payloads – note that the Flight Model is expected to be 30% lighter).

The rover features a deployable, adjustable suspension offering the possibility to adjust the chassis height from 0 to 300mm from ground, with a typical height of 170mm in regular navigation configuration. This feature allows adjusting the ground clearance to improve navigability on hazardous terrain. The same mechanism is exploited for on-spot drill positioning where the platform needs to touch the ground so that to obtain maximum depth with the drill. This also allows effective deployment and stowage of the rover (then fitting in a volume of 0.95m x 85 cm x 40 cm).



Figure 1: Left - nominal chassis height for navigation. Right: lowered chassis to perform drilling operation.

The rover is also equipped with a rocker-bogie mechanism offering a high obstacle clearance (up to 30cm) compared to the rover size. The rocker-bogie is implemented with an external differential bar located on the top of the chassis. This system increases the chances

* The LUVMI rover FM concept and characteristics (mass, power and thermal) analysis were covered in the project, but not prototyped.

that the four wheels of the rover stay in contact with the ground surface.



Figure 2: LUVMI rover, highlighting obstacle clearance

The LUVMI rover as presented in this paper and shown above on Figure 1 and Figure 2 is a ground prototype that we developed for locomotion testing, conops and instruments validation. Its mass, electric systems, power consumption and its thermal subsystem are thus not representative of a Flight Model*.

2.2 Volatiles Sampler and Volatiles Analyser

The integrated Volatiles Sampler (VS) and Volatiles Analyser (VA) instrument is a soil sampling, gas extraction and analysis instrument for the investigation of volatiles in lunar regolith. The system consists of a hollow drill shell, which is driven by a brushed DC motor for insertion into the ground. Once inserted, a heating element in the drill shell heats the regolith to extract volatiles in-situ in the ground. While some of the released gas escapes through the open bottom, the majority remains trapped inside the drill shell. Pirani pressure sensors monitor the gas pressure rise during heating, which can give some indication on the abundance of volatiles in the sample.

Directly above the drill shell sits the VA, which is a single unit comprising of an Ion Trap Mass Spectrometer (ITMS) and associated control electronics. The VA has heritage from the Ptolemy ITMS instrument (Figure 4) which made the first in situ measurements of volatiles and organics on comet 67P on-board the Rosetta lander, Philae in 2014 [8] [9]. The VA will address the scientific objective of identifying and the quantification of volatiles contained in the lunar regolith, at a number of regions

near the lunar pole. The device is a mechanically simple, low mass, volumetrically compact instrument that is capable of rapid detection of masses in the range of m/z 10 to 150 to extremely low detection levels making it ideal for detection of water and other volatiles that may be liberated from the lunar regolith.

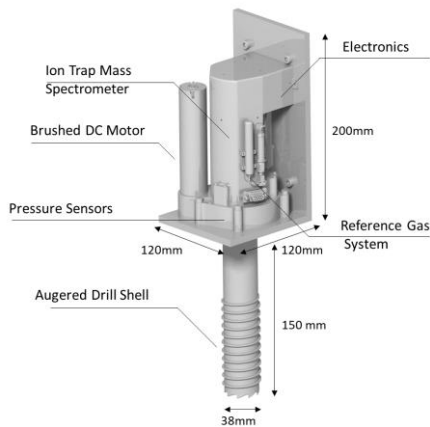

Figure 3: Render graphic and image of the Volatiles Sampler/Volatiles Analyser instrument

The VA consists of a number of discreet subsections, these being:

The ion source consists of an electron source which ionises the sample gas(s) via electron bombardment.

The mass selector is formed from three hyperbolic electrodes that form an electro potential region within their structure. By manipulation of the amplitude and the frequency of the potential on the hyperbolic electrodes, ions can be trapped or manipulated to eject them in order of their mass-to-charge ratio.

The detector, which consists of an electron multiplier that detects individual ions as they leave the mass selector and through a process of amplification multiplies this extremely low current associated with single ions into signals that can be measured by the control electronics.

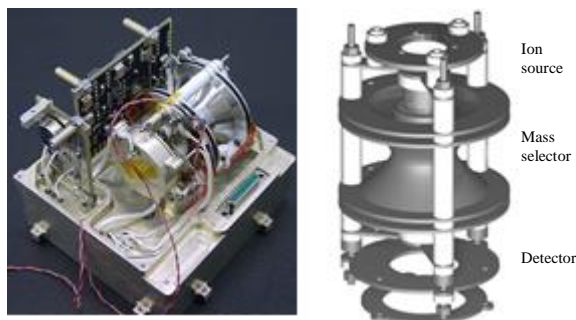

Figure 4: (Left) The Ptolemy ITMS with a mass range: 10 - 150 amu, resolution: 1 amu, mass: 500

gram, power: 15 W, dimensions approx. 10x10x10 cm. (Right) LUVMI VA structure

2.3 Light-field Imaging

Light-field cameras employ a unique lens arrangement to capture multiple dimensions of information about a scene within a single image exposure. Capturing both the intensity and direction of the incoming light enables the scene to be depicted through rich data products such as 3D or total focus images.

A part of the LUVMI suite of cameras provided by Dynamic Imaging Analytics employ this technology including, the Surface Camera (SurfCam) and Navigation Camera (NavCam).

SurfCam

SurfCam is mounted below the rover chassis and monitors both the rover tracks as well as the sampling site. It provides measurements of the depth of the rover wheel tracks as well as high definition optical verification of the sampling site before and after drilling.



Figure 5: The SurfCam prototype integrated into the LUVMI rover NavCam

NavCam is used to gather information about the LUVMI rover's surroundings. The primary function of the NavCam is to assist in navigation as the rover trajectory is planned and executed.

Using the pan and tilt, NavCam can build up a panorama of the lunar environment to assist operators in planning routes and choosing suitable sampling sites.

3. Test Campaigns and Results

4.1 Volatiles Sampler and Volatiles Analyser Tests Approach and Results

Before integration of the instrument, the VS and VA were tested separately, to weed out problems and raise system maturity. For the VS, a thermal-vacuum chamber was built at TUM that allowed testing of insertion and gas release under lunar-like conditions. The VA was tested in an existing vacuum chamber at the OU. End-to-end testing of the VA and VS was conducted in the thermal vacuum chamber at TUM.

3.1.1 Volatiles Sampler

On the lunar surface, the VS/VA instrument will sample lunar regolith under high vacuum and extreme temperature conditions. These conditions needed to be reproduced to allow meaningful testing of the VS/VA instrument. For this purpose, a thermal vacuum chamber was set up, that allowed testing of the mechanical insertion and gas extraction under simulated lunar conditions.

A schematic of the chamber is shown in Figure (below): The VS/VA system is suspended on a linear actuator above a 12 l sample container filled with JSC-1A [10] lunar regolith simulant. The simulant was doped with up to 5% of water and frozen to below -50°C before evacuation and testing.

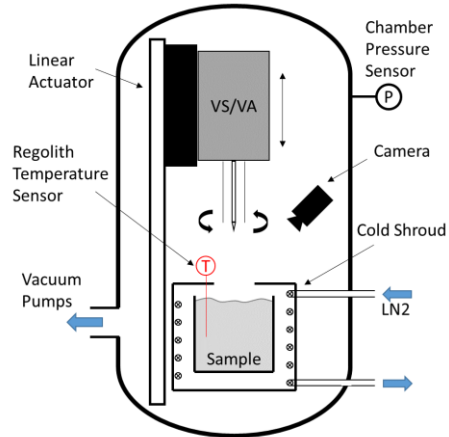

Figure 6: Schematic of the VS/VA test chamber

Results are shown in Figure XXX (below): Lowering of the VS was started at 00:00 and first contact with the surface occurred at 4 min. In all cases, significant amounts of volatiles were released when the VS (at ambient temperature) made contact with the frozen regolith simulant. The pressure rise was stronger for higher regolith contents. At 00:10, heating was started with 15 W constant power. Pressures levelled out at 10 mbar, due to sensor saturation, temperatures reached up to 400°C, depending on the regolith water content.

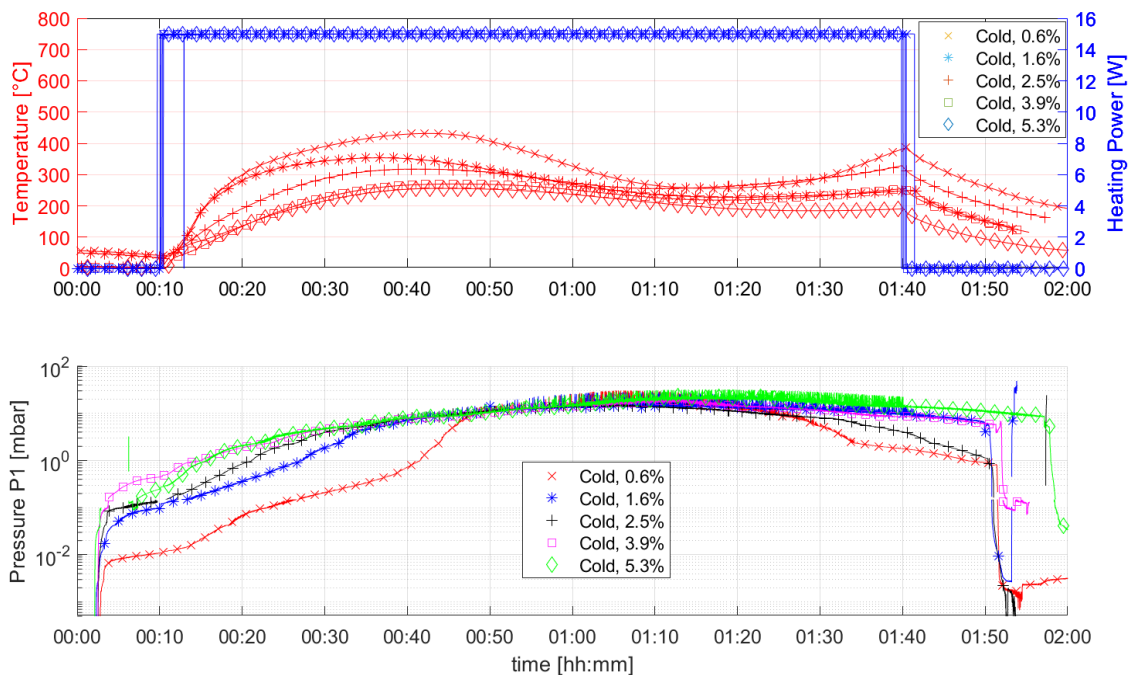

Figure 7: Gas extraction results with the VS and various water contents

3.1.2 Volatiles Analyser

Figure 8 shows the self-contained VA instrument. The filament ion source is shown at the top of the image, however in operation the ion source is pointing downwards towards the VS and the drive electronics enclosure points up-wards.

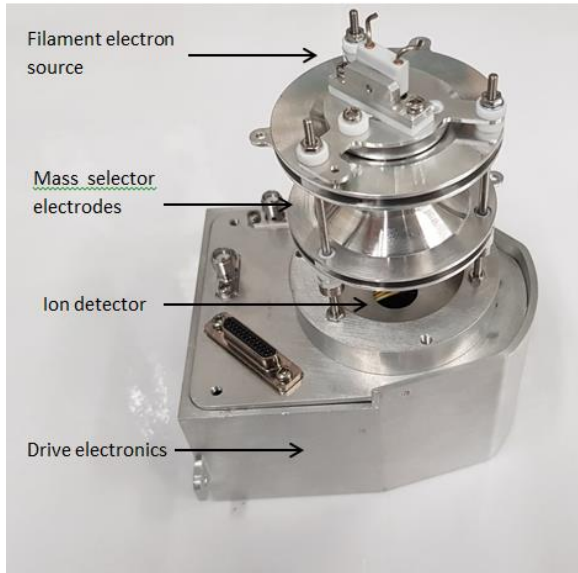

Figure 8: Image of the LUVMI VA ion trap mass spectrometer unit. mass: 700 gram, power: 8 W, dimensions approx. 13x10x10 cm.

Figure 9 shows the mass spectrum obtained with the LUVMI VA ITMS with a flow of PFTBA reference gas being admitted into the vacuum chamber. The pressure within vacuum chamber during the analysis was 2×10^{-6} mbar. The water peak ($m/z=18$) is always present and is a result of water vapour outgassing from the walls of the vacuum chamber

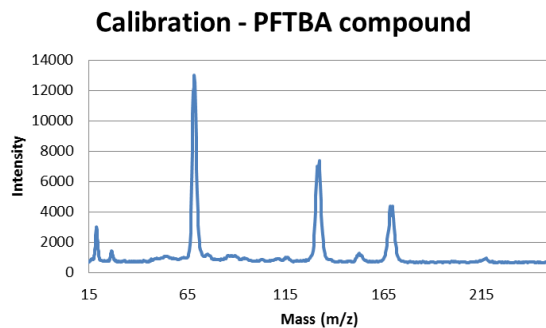

Figure 9: Mass spectrum of reference compound (PFTBA) obtained with the LUVMI VA ITMS showing mass range for the instrument.

3.1.3 Integrated VS + VA

The main objective of the test(s) was to demonstrate the extraction of volatiles by the VS combined with gas analysis with the VA. For this test, a sample of 0.2% water content was prepared at ambient temperature. Gas extraction results are shown in Figure (below). The VS/VA was inserted and 15 W heating was performed for 5 min, then the instrument was retracted and reinserted, after which a 90 min heating was performed. During the entire duration, the VA was operating and monitoring the evolved volatiles in test chamber.

The readings of the VA are shown in Figure 11. The top plot shows the water ($m/z = 18$) response over a 90 min period. The six individual plots show the mass spectra at different points in time. The mass spectra show a clean peak at $m/z = 18$ and a small response for $m/z = 16$ and 17, a very clear indication of water. The water response clearly rises over time, as the pressure increases inside the VA volume. In addition to water, N_2 and CO_2 are also observed in the mass spectra obtained indicating an air leak and contamination within the environmental chamber.

An image of the VS & VA system is shown in Figure 10. It features an augered drill shell of 150 mm length which can be rotated by a brushed DC motor for eased insertion. The VA is mounted on top of the drill.



Figure 10: (Left) The integrated VS & VA instruments (Right) The VS & VA mounted in the environmental chamber at TUM prior to end-to-end testing with lunar simulant material

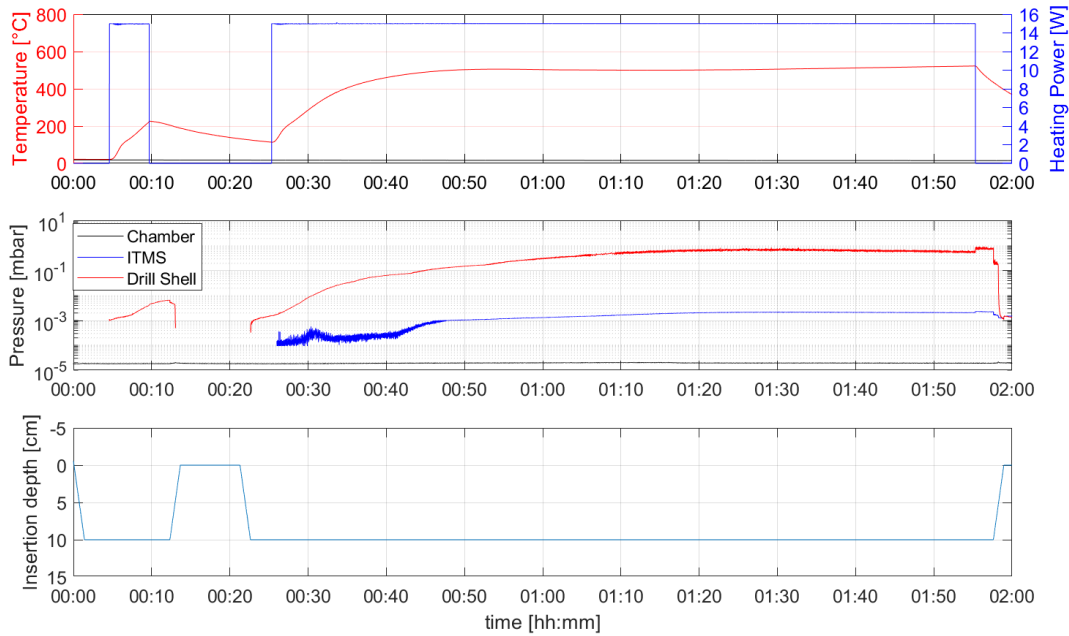

Figure 11: Gas extraction results of the integrated VS/VA test. Top Plot: Heater temperature and heating power; Center plot: Pressures of vacuum chamber, drill shell and VA volume; Lower Plot: Depth of insertion into regolith.

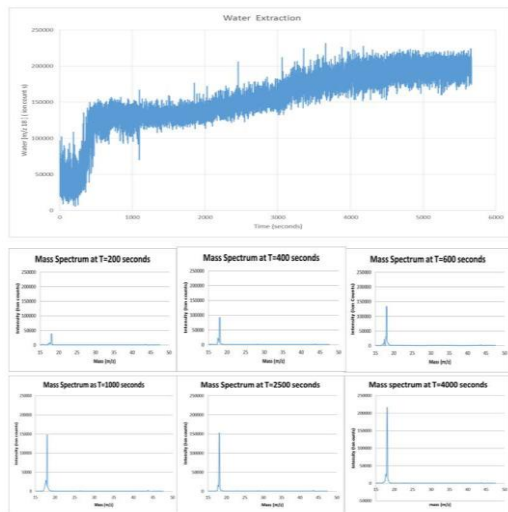

Figure 12: (top) showing the profile of $m/z=18$ (water) extracted from the simulant material during the 90 extraction experiment. The six individual mass spectra show increase in measured m/z 18 as the experiment progressed.

3.2 Light-field Imaging Tests Approach and Results

The light-field optics employed in both light-field cameras employ redundancy in multiple images that is used to generate 3-dimensional data products.

An example of 3-dimensional depth and highly accurate point cloud images can be seen below.

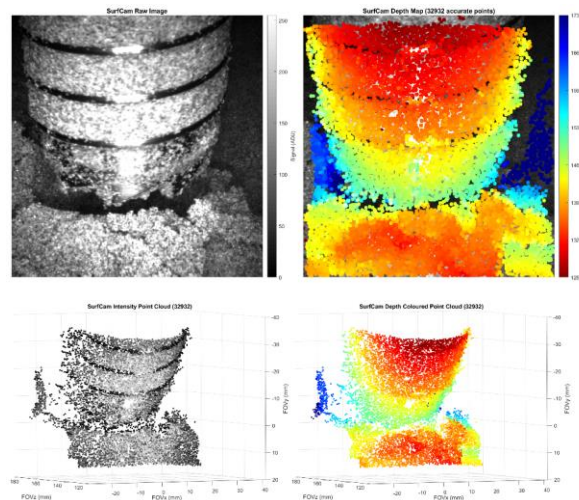

Figure 13: SurfCam image example during drilling

Typically, this 3D capability from a single snapshot imager comes at a cost to spatial resolution, however this redundancy can be exploited computationally to super resolve small regions of interest.

As the super-resolution process involves the summation of multiple images, the Signal to Noise Ratio (SNR) is increased, allowing for increased fidelity of pixel intensity data. In terms of exploration this provides an additional advantage in allowing for structures to be resolved that otherwise may not be possible due to specular reflection in a single image.

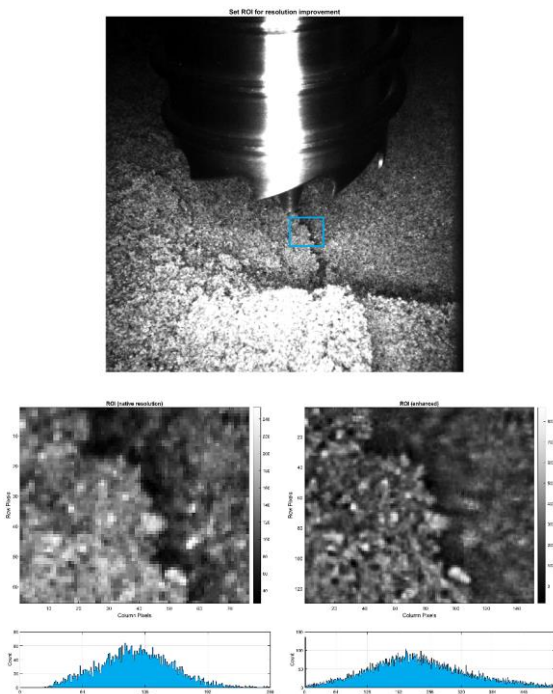

Figure 14: SurfCam super-resolution example immediately prior to drilling

3.3 Integrated Rover and Payload Tests Approach and Results

3.3.1 Partial Gravity Drilling Test

To validate that the required force on bit and drill depth can be achieved in reduced gravity conditions (1/6th of g), a gravity offloading setup was worked out for testing purpose. Off-loading the rover allows reducing the vertical force applied on the drill bit, and by reducing the weight on each wheel decreases the contact forces between each wheel and the ground.

The gravity off-loading system consists of a gantry positioned above the rover, holding a pulley system through which a cable is passed. The cable connects to a four points lifting system attached to the rover and a set of counterweights.

To increase the representativeness of the test, the rover wheels were placed on regolith simulant as shown in Figure 15.

The test campaign showed that the target drill depths were achievable even with an offloading level approaching lunar gravity conditions. In all scenarios the rover was unaffected by the drilling and no corrective manoeuvres were required to compensate for torques generated by the drill.

In addition the force sensor cells placed on the VA/VS assembly were shown to be precise enough to detect small obstacles in the path of the drill bit.

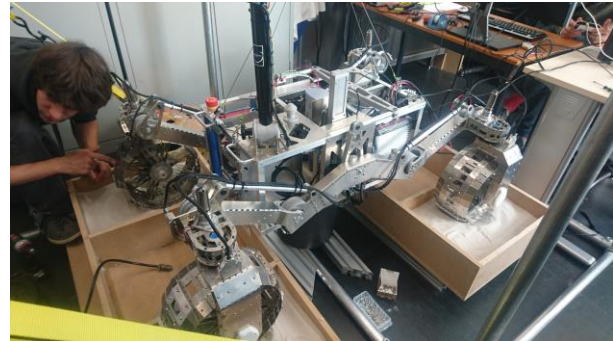

Figure 15: Partial gravity drilling test

3.3.2 Conops and Mobility Tests

The platform mobility tests were targeted towards end-to-end validation of the integrated systems.

As a first part of the mobility trials, the integrated LUVMI rover was deployed in a rocky (pebbles) terrain including a mix of flat and sloping areas (with simulated craters).



Figure 16: Mobility test on rocky (pebbles) terrain (credit: B. W. de Jong)

The tests gave evidence that slopes of 20 degrees could successfully be tackled by the rover, but the rocky nature of the ground unexpectedly translated in difficult conditions for the chassis structure. The grousers traction on pebbles gave rise to repetitive shocks, eventually stressing the attachment point of the drive trains. Small deformations could be noticed in lateral attachment plates that were not anticipated at design and simulation stages. Structural stiffness improvements are on the list of improvements, to mitigate such effects in upcoming evolutions of the rover platform.

The second part of the tests covered end-to-end notional scenario of operations, including a traverse of 50 meters in sandy region, stopping and performing a drilling operation, and then driving back to starting point. The tests were conducted at dusk requiring the rover to use its floodlight to illuminate the scene for the camera. The entire test was conducted in teleoperated or semi-teleoperated (short distance way point) mode, without line of sight.



Figure 17: LUVMI platform mobility and drilling operation testing

The traverse demonstrated the rover driving and spot-turning abilities. Once the target was reached the rover deployment mechanism lowered the chassis to the ground. A complete drilling operation was performed and images of the drill bit and borehole were acquired by the surface camera. Finally, the deployment mechanism raised the chassis back to the nominal driving height and the rover returned to its starting location. The end-to-end test was successful, and the complete drilling operation was performed nominally.

For what concerns mobility, the rover's behaviour on wet as well as dry sand terrain was irreproachable, and slopes steeper than 20 degrees (up to 22 degrees) could be successfully overcome. Furthermore, none of the issues previously encountered on pebble rocky terrain materialized in sandy conditions: the sand being much more compliant with wheels and grousers traction, the propagation of locomotion stress to the drive trains' structure was much lower.

The outcomes of the LUVMI test campaign are valuable information for LUVMI's follow-up activities, and are being carefully considered as driver design for the LUVMI-X rover platform in particular.

4. LUVMI-X concept

The LUVMI-X concept stems from LUVMI results, scientific community interest in the project and

LUVMI's capabilities, as well as expected evolution of opportunities to access the Moon in the coming decade.

In LUVMI-X we target lunar volatiles with four different instruments:

1. A laser-induced breakdown spectroscopy (LIBS) instrument, and
2. a radiation detector, both to remotely measure the (relative) abundances of hydrogen and other volatiles remotely and can thus be used to scout for areas of interest.
3. An upgraded VS/VA instrument to analyse the (absolute) volatile abundances at different depths and refines the characterization performed by the remote-sensing instruments, for example by distinguishing water from other forms of chemically-bound hydrogen, and
4. A set of rugged environmental sensors to form a Volatiles and Context Analysis Suite (VCAS) that can be deployed to an area of interest not accessible to the rover and can measure at a specific time (e.g. during a terminator crossing).

Combined, these four instruments are a powerful tool for comprehensively analysing the lunar regolith for its volatile content. The rover can thus be more effectively used as a scouting vehicle for volatiles than its predecessor.

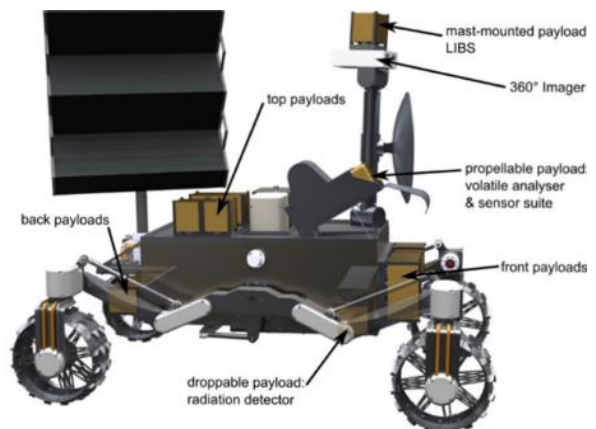

Figure 18: LUVMI-X notional concept

The LUVMI-X rover itself introduces a number of innovations that lower the costs and technological barriers for new communities wishing to access the lunar surface. It will support surface payloads using the cost-effective CubeSat form-factor. It provides standardized interfaces for payload accommodation attaching/detaching enabling third-party researchers to provide additional payloads to LUVMI-X. Architecture incorporating “plug and play” and standard interfaces

also opens the door to easily test, verify and demonstrate new technologies on the lunar surface. We expect the LUVMI-X rover to be able to accommodate a total payload mass of ~25kg, with a dry rover mass as close as possible to 25kg too.

The LUVMI-X concept foresees three innovative low mass payload families in addition to the existing instrumentation developed in LUVMI:

1. Mounted payload for local remote sensing through “geochemical vision”;
2. Droppable (de-mountable / re-mountable) payload for long-duration environmental monitoring; these can be placed on the surface by lowering the active suspension system of LUVMI, without the need for a robotic arm;
3. Propellable payloads to analyse areas not accessible to a rover.

The concept may address the following possible mission applications (one or a combination thereof):

- Stand-alone Lunar Volatile Prospecting mission: LUVMI-X is deployed on the lunar surface. It utilizes its instrument suite to investigate cold-trapped lunar volatiles in and around permanently shadowed areas near the lunar poles.
- Third-party payload carrier: The LUVMI-X rover is used as a commercial service that provides payload slots to institutional customers
- Gateway - HERACLES precursor mission: LUVMI-X is launched prior to HERACLES. Astronauts on Lunar Orbital Platform - Gateway teleoperate the rover on the lunar surface.
- Pyroclastic vent investigation: LUVMI-X approaches a pyroclastic vent (or another area inaccessible for rovers) and project its propellable payload into the crevice.
- ISRU Demonstrator precursor mission: LUVMI-X is launched before the ISRU Demonstrator mission, providing ground truth to characterise the feedstock in the area surrounding the lander

5. Conclusions

The LUVMI mobile instrumentation concept was successfully implemented and tested, as a ground prototype. The Volatiles Sampler and Analyser instruments were tested at TRL 5-6, while the rover mobility concept was tested at TRL 4-5. The test campaign carried out in late 2018 allowed verifying the

concept of operation and assessing mobility performances in different challenging conditions.

Leveraging LUVMI’s results, LUVMI-X will allow carrying a wider and more versatile set of instruments – primarily targeting volatiles (more comprehensively than what LUVMI was intended to) in its original configuration, but also offering new advanced capabilities to host and deploy instruments packaged in as modules (cubesat inspired). With this, we expect LUVMI-X to reach the market as a viable solution to take customer payloads to strategic locations on the moon and maximizing science benefit, at more affordable conditions than what other approaches may allow.

Acknowledgements

The LUVMI project was co-funded by the European Commission through its Horizon 2020 programme under grant agreement #727220; the LUVMI-X project is co-funded by the European Commission through its Horizon 2020 programme under grant agreement #822018.

References

- [1] Clark, R. N. 2009 . Detection of Adsorbed Water and Hydroxyl on the Moon. *Science - Vol 326*. 2009 , pp. 562 - 564.
- [2] Colaprete, Anthony, et al. 2010. Detection of Water in the LCROSS Ejecta Plume. *Science*. 2010, pp. 463-468.
- [3] Feldman, W. C., et al. 1998. Fluxes of Fast and Epithermal Neutrons from Lunar Prospector: Evidence for Water Ice at the Lunar Poles. *Science, Vol 281*. 1998, pp. 1496 -1500.
- [4] Mitrofanov, I., et al. 2012. Testing polar spots of water-rich permafrost on the Moon: LEND observations onboard LRO. *Journal of Geophysical Research: Planets, Vol 117*. 2012.
- [5] Nozette, S., et al. 1996. The Clementine Bistatic Radar Experiment. *Science, Vol 274*. 1996, pp. 1495--1498.
- [6] Pieters, C. M., et al. 2009. Character and Spatial Distribution of OH/H₂O on the Surface of the Moon Seen by M3 on Chandrayaan-1. *Science*. 2009, pp. 568-572.
- [7] Sunshine, J. M., et al. 2009. Temporal and Spatial Variability of Lunar Hydration As Observed by the Deep Impact Spacecraft. *Science, Vol 326*. 2009, pp. 565-568.
- [8] Wright, I.P., et al., “CHO-bearing organic compounds at the surface of 67P/Churyumov-Gerasimenko revealed by Ptolemy,” in *Science*, vol. 349, no. 6247, 2015.
- [9] Morse, A.D., et al., "The Rosetta campaign to detect an exosphere at Lutetia," in *Planetary and Space Science*, vol. 66, no. 1, pp. 165–172, 2012.
- [10] Zeng, X., et al. 2010. Geotechnical Properties of JSC-1A Lunar Soil Simulant. *Journal of Aerospace Engineering*. 2010, pp. 111-116.