

Open Research Online

The Open University's repository of research publications and other research outputs

The natural history of immune responses to malaria

Thesis

How to cite:

Muchina Kinyanjui, Samson (2002). The natural history of immune responses to malaria. PhD thesis. The Open University.

For guidance on citations see [FAQs](#).

© 2002 Samson Muchina Kinyanjui

Version: Version of Record

Copyright and Moral Rights for the articles on this site are retained by the individual authors and/or other copyright owners. For more information on Open Research Online's data [policy](#) on reuse of materials please consult the policies page.

oro.open.ac.uk

**THE NATURAL HISTORY OF IMMUNE
RESPONSES TO MALARIA**

SAMSON MUCHINA KINYANJUI

A thesis submitted to the Open University (UK) for the degree of

DOCTOR OF PHILOSOPHY

DECEMBER 2001

DISCIPLINE: LIFE SCIENCES

SPONSORING ESTABLISHMENT

Weatherall Institute of Molecular Medicine
University Of Oxford, Oxford

COLLABORATING ESTABLISHMENT

Center for Geographic Medicine Research - Coast
(KEMRI/Wellcome Trust Collaborative Program)
Kilifi, Kenya

DATE OF SUBMISSION: 31 DECEMBER 2001
DATE OF AWARD: 3 DECEMBER 2002

ProQuest Number:27532777

All rights reserved

INFORMATION TO ALL USERS

The quality of this reproduction is dependent upon the quality of the copy submitted.

In the unlikely event that the author did not send a complete manuscript and there are missing pages, these will be noted. Also, if material had to be removed, a note will indicate the deletion.



ProQuest 27532777

Published by ProQuest LLC (2019). Copyright of the Dissertation is held by the Author.

All rights reserved.

This work is protected against unauthorized copying under Title 17, United States Code
Microform Edition © ProQuest LLC.

ProQuest LLC.
789 East Eisenhower Parkway
P.O. Box 1346
Ann Arbor, MI 48106 – 1346

ABSTRACT

Available evidence suggests that responses to the parasite-induced antigens on the surface of red cells infected by mature stages of *P. falciparum* (PIESA) confer variant-specific immunity against malaria. However, much of the available data are derived from cross-sectional or longitudinal studies restricted to a few weeks after a malaria episode. As such, the natural history of antibody responses to PIESA is poorly documented. I set up a longitudinal framework to examine the kinetics, dynamics, and protective efficacy of anti-PIESA responses in children in Kilifi. I also used the same the framework to explore responses to other schizont antigens.

The majority of children mounted typical primary antibody responses against PIESA within two weeks of an acute episode and sustained the levels for more than 12 weeks. However, some children appear to have inadequate responses that failed to persist beyond twelve weeks. When followed up over a year period, all the children showed loss and acquisition of anti-PIESA specificities regardless of their disease experience during the period. This suggests that anti-PIESA response may be short-lived and this might be related to the predomination of the responses by short-half life IgG3 or with failure to switch from IgM to IgG.

Anti-PIESA antibody responses to certain randomly selected parasite isolates were associated with protection from subsequent clinical episodes either independently or in synergy with concurrent malaria infection. However, this protection was not related to the relative frequency with which the target isolates appear to have been encountered by the children during the follow-up period.

Besides anti-PIESA responses, possession of antibodies to a 192 kDa schizont antigen band on a Western blot was also associated with protection against clinical episodes of malaria. IgG1 and IgG3 dominated responses to all the bands on the blot and for some antigens; IgG3 responses were present only in pooled plasma from immune but not non-immune individuals.

More studies are necessary in order to understand further the kinetics and dynamics of antibody responses to PIESA and other schizont antigens and the mechanisms underlying the protection against malaria that they provide.

ACKNOWLEDGEMENTS

I owe gratitude to several people who in one way or another contributed to the successful completion of this thesis. I would like to begin by expressing my sincere thanks to my supervisors, Prof. Kevin Marsh at the Wellcome Trust / KEMRI laboratories in Kilifi and Prof. Chris Newbold at the Weatherall Institute of molecular Medicine in Oxford for the wonderful opportunity to carry out the work in their laboratories. I am very grateful for their excellent yet friendly supervision, technical and intellectual guidance. This work was funded by the Wellcome Trust (UK).

I am particularly grateful to Tabitha Mwangi with whom I collaborated in setting up the longitudinal studies. The whole field work team and especially Garama Baya who was specifically assigned to my studies deserves special mention for carrying out their work faithfully and in a manner that ensured that good quality of data was obtained from the longitudinal studies.

Pete Bull has been a wonderful “online” help on many technical and intellectual issues.

I am not sure that I could have found a better working environment elsewhere than I did in Kilifi, thanks to everyone in the Center and especially to: Dr. Peshu; Brett Lowe, for all the help in ensuring I had all the supplies and equipment that I required, Amanda Ross and Antony Scott for their advice on data analysis, Tom Oluoch and Joe Kaduda for the computing support; Kath maitland – lovely office mate, “Sir” Francis Ndungu; Oscar Kai; Moses Mosobo; Jack Obiero; “Prof. Murtala” Mohamed; Charles Newton, Barnes Kitsao, Liz Igombo and Martin Mwakala.

Many thanks to Bob Pinches, Dave Roberts, Neline Kriek, Sue Kyes, Rebecca, Paul Horrocks, Zoe Christodolou, Barry Elford, Sarah Lee, Clement Pascal, Arnab Pain and Britta Urban at the Malaria lab in the WIMM and to Kate Flanagan, Frances Sanderson, and Jane Crawley for making my stay in Oxford a very easy and enjoyable one.

Thanks to my mum and brothers who have always been a great source of encouragement to me. Finally, I would like to acknowledge the loving and wonderful support of my dear wife, Patricia and to express my appreciation for her enduring patience on the many evenings that I was away in the lab or writing up this thesis.

CONTENTS

ABSTRACT	I
ACKNOWLEDGEMENTS	II
CONTENTS	III
LIST OF FIGURES	VIII
LIST OF TABLES	X
CHAPTER 1 - INTRODUCTION	
1.1 MALARIA – THE CURRENT OUTLOOK	1
1.2 PARASITE AND VECTOR	5
The life cycle of malaria parasites	6
1.3 EPIDEMIOLOGY OF MALARIA	7
Geographic distribution of malaria	7
Parameters used to measure malaria transmission	10
Mathematical modelling of malaria transmission	11
The burden of malaria disease in Africa	11
The Relationship between transmission, age and distribution of disease.	13
The risk of severe malaria in relation to transmission intensity	16
1.4 THE CLINICAL FEATURES OF MALARIA	17
Fever	18
Anaemia	18
Hypoglycaemia	19
Respiratory Distress	19
Neurological involvement	20
Prognostic indicators in malaria	20
The pathogenesis of cerebral malaria (CM)	21

1.5 THE IMMUNOLOGY OF MALARIA	27
Genetic resistance to malaria	28
Acquired immunity	33
Immune effector mechanisms in malaria immunity	40
Malaria antigens that are targets for immune response.	49
Immune response to parasite induced erythrocyte surface antigens (PIESA)	69
1.6 JUSTIFICATION AND OBJECTIVES	76
CHAPTER 2 - MATERIALS AND METHOD	
2.1 STUDY SITE	78
2.2 ETHICAL CONSIDERATIONS	79
2.3 LABORATORY METHODS	79
Parasite culture	80
Agglutination assays	84
Flow cytometry	87
2.4 VALIDATION OF THE LABORATORY METHODS	90
Validation of the agglutination scoring method	90
Effects of repeated freezing and thawing plasma on agglutination antibodies	91
Inter-assay variation	92
Correlation between antibody titres and flow cytometry parameters	94
The use of cryopreserved schizonts in agglutination assays and flow cytometry	96
2.5 DISCUSSION	105
2.6 LONGITUDINAL STUDIES.	111
Kinetics of anti-PIESA responses (chapter3).	111
The dynamics and protective role of anti-PIESA responses (chapters 4, 5, 6, 7).	111
CHAPTER 3 - THE KINETICS OF ANTIBDOY RESPONSES TO PIEASA	
3.1 INTRODUCTION	115
3.2 STUDY DESIGN	115
Patients and blood sampling	115
Agglutination assays	116
Flow cytometry	117
Data analysis	117

3.3 RESULTS	
General results	117
Prevalence of antibodies to homologous parasites over time.	118
Isotypes profiles of anti-PIESA antibodies.	119
Factors influencing rate and magnitude of response	119
Individual agglutination profiles	122
Antibody profiles and re-parasitisation.	124
3.4 DISCUSSION	124

CHAPTER 4 - THE DYNAMICS OF THE ANTI-PIESA REPOSES OVER TIME

4.1 INTRODUCTION	129
4.2 STUDY DESIGN	130
Agglutination and flow cytometer assays	130
Data analysis	131
4.3 RESULTS	132
Prevalence of antibodies to the test isolates at the first survey.	132
Correlation between the prevalence of specific anti-PIESA and age	132
Variation in the agglutinating antibodies repertoire over one-year period	134
4.4 DISCUSSION	142

CHAPTER 5 - PROTECTION AGAINST CLINICAL EPISODES OF MALARIA BY VARIANT-SPECIFIC RESPONSES AGAINST PIESA

5.1 INTRODUCTION	149
5.2 STUDY DESIGN	150
Data analysis	150
5.3 RESULTS	151
General Observations	151
The prevalence of antibodies to the test isolates	153
Relationship between specific anti-PIESA antibodies and age.	154
Correlation between specific responses to each isolate and the total number of isolates that a child recognised.	155
Relationship between anti-PIESA antibodies and risk of clinical episodes.	155

The relationship between protection against clinical episodes by anti-PIESA responses and the relative frequency of isolates in the local transmission system.	156
5.4 DISCUSSION	158
 CHAPTER 6 - PROTECTION AGAINST CLINICAL MALARIA BY ANTIBODIES AGAINST SCHIZONT ANTIGENS	
6.1 INTRODUCTION	162
6.2 STUDY DESIGN	162
6.3 MATERIALS AND METHODS	163
Parasites culture and antigen extraction	163
Preparation of polyacrylamide gels	163
Electrophoresis .	165
Electroblotting	165
Probing the blots with antibodies	166
Data analysis	167
6.4 RESULTS	167
Antibody responses to un-infected red cell proteins	167
Individual reactivity to malaria antigens	168
Prevalence of antibodies against each protein band	170
Correlation between age, episodes, and reactivity to various antigens.	170
Correlation between IgG levels in the pooled plasma and immune status	172
Isotypes of antibodies directed against schizont antigens	173
6.5 DISCUSSION.	173
 CHAPTER 7 - THE RELATIONSHIP BETWEEN PARASITOLOGICAL STATUS AND ANTIBODY RESPONSES TO PIESA AND OTHER SCHIZONT ANTIGENS	
7.1 INTRODUCTION	180
7.2 STUDY DESIGN	180
Data analysis	181
7.3 RESULTS	182
Prevalence of microscopically-detectable infections	182
Association between parasitological status and an individual's repertoire of anti-PIESA specificities	183
Association between parasitological status and anti-PIESA responses	183

Association between parasitological status and protection against clinical episodes of malaria by anti-PIESA antibodies .	184
Association between parasitological status and antibody response to malaria antigens on a Western Blot	185
7.4 DISCUSSION	187
CHAPTER 8 - SUMMARY	
Materials and Methods	193
Kinetics of anti-PIESA responses to homologous Parasites	194
The dynamic of the acquisition of Anti-PIESA antibodies over time	195
Protection against clinical episodes of malaria by anti-PIESA responses	196
Assessment of the protective efficacy of responses to schizont antigens using Western blots	197
The influence of parasitological status on the levels and protective efficacy of responses to PIEsa and other schizont antigens	198
Final comments	199
REFERENCES	200
APPENDICES	224

LIST OF FIGURE

1.1	The life cycle of malaria parasites.	9
1.2	A classification of malaria transmission based on the basic reproduction rate (R_0).	12
1.3	The relationship between age and the prevalence and incidence of malaria.	15
1.4	Prevalence and mortality rates of major subgroups of severe malaria in Kilifi.	23
1.5	Malaria parasite antigens that may be targets for host immune response.	52
1.6A	Schematic diagram of <i>P. falciparum</i> telomeres showing the location of var gene.	62
1.6B	Schematic diagram of A4var gene domains organization.	62
1.7	Molecules on the infected red cell and vascular endothelium that are implicated in cytoadherence.	65
2.1	A map of Kenya showing the location of Kilifi.	79
2.2	A clone tree showing the derivation of some the parasite clones used in the thesis.	81
2.3	A photomicrograph of agglutinated infected red cells.	86
2.4	An example of a flow cytometer graphic output.	89
2.5	Scatter plots of scores of duplicate agglutination slides from a single assay.	90
2.6	The effect of repeated freezing and thawing of serum on agglutinating antibodies.	92
2.7	Inter-assay variation in agglutination assays.	93
2.8	Correlation between plasma dilution and levels of antibodies detected by flow cytometry.	95
2.9	Agglutination profiles of fresh and cryopreserved schizonts.	101
2.10	Reactivity of fresh and cryopreserved schizonts on flow cytometry.	102
3.1	The prevalence (A) and geometric mean titres (B) of agglutinating antibodies to homologous parasites at various time points after an acute episode.	118
3.2	Isotype profiles of anti-PIESA responses at various time points after an acute episode.	120
3.3	Kinetics of agglutinating antibody in children during convalescence from an acute episode.	123
4.1	Graph showing the increase of the prevalence of anti-PIESA responses to various isolates with age.	133
4.2	A checkerboard showing the variation of agglutinating antibodies in children over a period of one year.	137
4.3	A checkerboard showing the variation of anti-PIESA responses measured by flow cytometry over a period of one year.	138
4.4	The rate of sero-conversion to a PIESEA variant plotted against the initial prevalence of antibodies to the variant.	141

LIST OF FIGURE *cont'd...*

5.1	The percentage of children who presented with at least one clinical episode of malaria during the follow-up.	152
5.2	The number of isolates a child recognised plotted against the child's age.	153
5.3	Anti-PIESA antibody responses to various isolates plotted against age.	154
6.1	IgG response to un-infected red cell proteins.	168
6.2	A sample of blots from individuals with different levels of responses to schizont antigens	169
6.3	The prevalence of antibodies against various schizont antigens stratified by age and immune status.	171
6.4	IgG responses to schizont antigens (pooled plasma).	172
6.5	Isotype analysis of responses to schizont antigens (pooled plasma).	175
7.1	The prevalence of microscopically-detectable infections stratified by age.	182

LIST OF TABLE

2.1	Recovery of cryopreserved schizonts	98
2.2	Levels of Mixed agglutination between cryopreserved schizonts of different isolates	99
2.3	Reactivity of fresh and cryopreserved schizont measured on flow cytometry	103
2.4	Correlation between agglutination and flow cytometry	104
4.1	The number of children within each age category whose plasma was assayed by flow cytometry and agglutination assays	131
4.2	The dynamics of anti-PIESA responses over a one year period	134
4.3	The mean number of specificities acquired and lost during the year in relation to disease experience	139
4.4	The mean number of specificities acquired and lost during the year in relation to age	140
5.1	Mean number of episodes per child during a two year period	152
5.2	The prevalence of anti-PIESA antibodies to various isolates	153
5.3	Correlation between a child's responses each of the test isolate and the number of test isolates to which the child had antibodies	155
5.4	The protective efficacy of anti-PIESA responses to various test isolates	157
6.1	Buffers used to cast gels for SDS-PAGE and the composition of gels at various strengths	165
7.1	Effects of a current infection on anti-PIESA response to various isolates	184
7.2	Interaction between current infection and anti-PIESA responses in protection against clinical malaria	186

CHAPTER 1

INTRODUCTION

1.1 MALARIA – THE CURRENT OUTLOOK

It has been about 100 years since the discovery of malaria parasites by Alphonse Levaran and the demonstration of the role of mosquitoes in the transmission of malaria by Ronald Ross. These events along with the contribution of other early malariologists such as Grassi, Bignami, and Bastianelli facilitated the understanding of the life cycle of malaria parasites and ushered in a period of intense optimism on the possibility of completely eradicating malaria. Unfortunately, a century later, malaria remains one of the leading causes of morbidity and mortality in the world. It is estimated that over 400 million people are infected by malaria parasites each year resulting in about 1 million deaths, the majority of which occur among children in the tropical regions (WHO, 1996). In spite of increased knowledge of the parasite's biology and the availability of advanced technology for malaria research, there has been little success in eradicating malaria. Indeed, the hopes of complete eradication have given way to a more pragmatic goal of controlling malaria disease.

Many factors have collaborated in frustrating efforts to eradicate malaria. Although vector control programmes such as DDT residual spraying proved successful in eliminating malaria in temperate regions where transmission was initially low, they have failed to make much headway in the tropical regions. The vector systems in these regions are extremely efficient and robust and meaningful reduction in transmission can only be achieved through very intense and sustained efforts. Even slight relenting in control efforts results in transmission rapidly bouncing back to pre-control levels. Unfortunately, the majority of countries where malaria is endemic are unable to bear the cost of sustained control programmes.

Consequently, many of the programmes have collapsed leading to the re-emergence of malaria where some control had previously been achieved. In addition, the emergence of insecticide-resistant mosquitoes, coupled with the need to limit insecticide use due to their adverse effects on the environment, have also been important factors in the failure to control malaria. Currently, vector control is focused on the use of insecticide treated bed-nets (ITBN). Although ITBN have proved efficacious in reducing severe malaria morbidity and mortality among children, there are concerns over their sustainability and long-term effects on the development of malaria immunity.

Chemotherapy is the mainstay of malaria control, but it is being severely undermined by the rapid emergence and spread of parasite resistance to the currently available drugs. There is now widespread resistance to chloroquine in many malaria-endemic areas and in the absence of equally cheap alternatives, a rise in malaria morbidity and mortality is expected. Whereas a vaccine might provide the best alternative to drugs, the search for a malaria vaccine has proved to be even more frustrating. It is now clear that immunity to malaria parasites is much more complex than immunity to many bacteria and viruses against which highly effective vaccines have been developed. Malaria parasites employ a diverse array of counter-measures against the host immune system and even where immunity is achieved, it is incomplete. Unfortunately, the market for anti-malarial drugs and vaccines is very impoverished and as such there is little impetus for the pharmaceutical companies to invest in the development of such drugs and vaccines. To date, despite the death toll from malaria, the amount of money that has been committed to malaria drugs and vaccine development is paltry compared that invested in cancer or HIV drugs.

Besides the inability to sustain control programmes or afford alternatives to chloroquine, many of the countries that bear the burden of malaria are plagued with many social-political problems that further hinder attempts to control malaria. Even where anti-malarial drugs are available by subsidy, overstretched supply lines, logistic problems, and social-political upheavals with the associated population dislocation are major handicaps. At the same time, changes in global climate and ecologies due to natural and human activities are redefining the seasonality and geographic extent of malaria transmission making control activities difficult to plan.

Finally, the emergence of the HIV epidemic in malaria endemic areas poses a particularly difficult challenge. Although the direct effects of HIV infection on malaria associated morbidity and mortality are not clearly established, by placing an unprecedented demand on the already meagre health resources, HIV is bound to have a major negative impact on malaria control.

However, not all news from the malaria war front is negative. The publishing of the completed *P. falciparum* chromosome 2 and 3 nucleotide sequences in 1998 and 1999 respectively was something of a boost to the dwindling optimism in malaria research. Another 8 out the 12 remaining chromosomes are already in the closure phase and could be published in the near future. Availability of all this genetic information is opening up new possibilities and approaches in all aspect of malaria research ranging from basic parasite biology to drugs and vaccine development. Besides having much promise in terms of valuable data, the Malaria Genome project is also good lesson for malaria research; an example of how much more quickly results can be achieved when different teams work in concert towards a common goal.

After a period of neglect, malaria control has begun finding its way back into the priority lists of major funding organisations. This follows a realisation that only through more concerted efforts and radically more funding than has been available hitherto can any hope of curbing malaria be realised. This renewed campaign against malaria was spearheaded by initiation of the Roll Back Malaria campaign by the WHO in 1998 with an aim of cutting malaria deaths by half by the year 2010 and has resulted in pledges of increased funding by many donor agencies. The G-8 group of nations have promised billions of dollars to fight malaria, AIDS and TB while the World Bank is pledging over \$300 million interest-free loans to fight diseases especially in Africa. New players such as the Bill and Melinda Gates foundation, which has donated over \$100 million for malaria research, have recently joined the field.

At the same time, several international alliances of organisations have been formed with an aim of maximising the impact of malaria research. The Multilateral Initiative on Malaria (MIM) is one such alliance. MIM emerged following a number of consultative meetings between African scientists and key players in malaria research from developed countries. Its overarching goal was thus defined at a meeting in 1997 in Dakar; *“To strengthen and sustain through collaborative research and training, the capability of malaria endemic countries in Africa to carry out research required to develop and improve tools for malaria”*. Though not a funding body itself, MIM has played a significant role in drawing additional funds for malaria research into Africa and has given the impetus for the formation of several other multi-centred malaria research initiatives and networks: the Severe Malaria in African Children network (SMAC); the Mapping Malaria Risk in Africa (MARA) project and the African Malaria Vaccine testing Network (AMVTN) to mention a few. It is hoped that this renewed campaign will achieve tangible progress against malaria before donor fatigue sets in again.

1.2 PARASITE AND VECTOR (Fig 1.1)

Malaria is caused by protozoan parasites of the Plasmodium genus. Of the nearly 200 species in this genus, four: *P. ovale*; *P. malariae*; *P. vivax* and *P. falciparum* are infectious to man under natural conditions. The last species is responsible for much malaria morbidity and practically all the mortality. The genus Plasmodia belongs to the apicomplexa, a large phylum of parasitic protozoa that are characterized by the possession of an apical complex organelle that lends the phylum its name. The phylogeny of human malaria parasites remains controversial, although there is a general consensus that the four species evolved separately and became parasitic on humans at different times in history. It has been suggested that the malignancy associated with *P. falciparum* infections might reflect a relatively recent cross over by this species into humans. However, phylogenetic studies on the parasite's ribosomal RNA suggest that *P. falciparum* diverged from its closest relative, the apes parasite *P. reichenowi*, about 11 million years ago which is about the same time that man and apes are thought to have diverged (Ayala, *et al.*, 1999). Thus *P. falciparum* may have been infecting humans since the beginning of hominid evolution.

Human malaria parasites are transmitted by female mosquitoes of the anopheles genus. This genus consists of a large number of species that differ in their capacity to transmit malaria depending on their biology and feeding habits. The spatial-temporal distribution of these vectors together with climatic factors that influence parasite development in the vector delineate the extent of malaria transmission. The *Anopheles gambiae* complex with its six sibling species and *A. funestus*, all found in Africa, form the most efficient malaria vector system and have greatly contributed to the difficulty of controlling malaria in this continent.

The life cycle of malaria parasites

Members of the genus plasmodia exhibit two phases during their life cycle. Within the definitive host they exist as haploid forms while fertilization takes place in the vector to produce a diploid zygote, which then undergoes cell division to give rise to haploid forms that can re-infect the definitive host. The vector phase in human malaria begins when a female anopheline mosquito picks up mature malaria gametocytes along with its blood meal. Once in the mosquito guts, the male gametocyte release about eight motile male gametes through a process know as exflagellation. If the male gametes find a female gametocyte fertilization takes place giving rise to a zygote. The zygote develops into a motile oökinete that penetrates through the mosquito gut lining into the haemocoel and attach on the outer wall of the gut. A multiplicative process called sporogony begins giving rise to a large number of haploid motile sporozoites. These sporozoites find their way to the mosquito salivary gland and are injected into the human host when the mosquito seeks another blood meal. The whole mosquito phase takes about 15 days but is dependent on ambient temperature and humidity, being longer when temperatures are low.

Once inside the human body, the sporozoites finds their way into the liver cells (hepatocytes) where pre-erythrocytic schizogony takes place and up to 30,000 daughter cells known as merozoites are formed. After about 7 days, the hepatocytes burst to release the merozoites into the blood stream. Merozoites invade red blood cells with the aid of the apical complex organelle and begin their erythrocytic stage. Initially parasites appear as a ring of cytoplasm surrounding a large vacuole with a small nucleus on the periphery. Within the next 24-36 hours the rings grow and the vacuole decreases, then schizogony begins again. Between 8-32 merozoites are produced in erythrocytic schizogony. After 48 hours in case of *P. falciparum*, the merozoites mature causing the hosting red cell to rupture. The merozoites re-invade new

red cells to begin another erythrocytic cycle. Not all ring trophozoites mature into schizonts, a small proportion undergo morphological changes and sexual differentiation to become male and female gametocytes. After about 8- 10 days the gametocytes mature and are ready to be taken up by a mosquito for the vector phase to begin.

1.3 EPIDEMIOLOGY OF MALARIA

In this section I will discuss the geographical distribution of malaria, the classification of endemicity, the malariometric parameters used and various methods used to obtain them. Then I will discuss the pattern of malaria infection and disease incidence in relation to age and transmission intensity and the implications for immunity to malaria.

Geographic distribution of malaria

The baseline factors that determine the probability of malaria transmission in an area are the presence of climatic and ecological conditions appropriate for anopheline mosquitoes and the development of malaria sporozoites in the vector. At least 80mm of rainfall annually and an average temperature of over 18 °C for at least five contiguous months are necessary for malaria transmission (Snow, *et al.*, 1999). However, the limits set by climatic conditions may be modified by human activities such as agriculture, urbanization, mass population movement, and malaria control programmes.

Until the beginning of the 20th century when effective methods of control were discovered, the global distribution of malaria was much more extensive than it is now. Malaria is reported to have been a serious scourge in Europe along the Mediterranean Sea and as far north as England and the steppes of Russia. Limited transmission also occurred in the southern part of the United States of America. Today, malaria transmission is largely

restricted to the tropical regions, with Africa bearing by far the largest burden of the disease. Outside Africa, malaria transmission occurs in the Amazon region in South America, Central America, the Pacific islands, the Indonesian peninsula and Papua New Guinea, South East Asia, the Indian subcontinent and the Middle East.

Climatic conditions that are suitable for malaria transmission exist over much of Africa except in the Sahara, Namib, and Kalahari deserts where water is absent, and in the East African highlands, and the Southern tip of Africa where altitude and latitude respectively allow the average temperature to fall below 18 °C (Snow, *et al.*, 1999; Hay, *et al.*, 2000). On the other hand, even in areas with very low rainfall, malaria transmission occurs along rivers, and where there are irrigation schemes. There has been little success in eradicating malaria in Africa. Only in the central highlands of Madagascar has substantial and sustained reduction in transmission been achieved through mass chemotherapy and residual spraying. The main vectors in Africa are the *Anopheles gambiae* complex, *A. funestus*, *A. nili*, and *A. moucheti* (Fontenille and Lochouart, 1999). Most of malaria in Africa is caused by *P. falciparum*, as a large proportion of the population possess Duffy-negative red cells, which are resistant to invasion, by *P. vivax* (Miller, *et al.*, 1976; Miller, *et al.*, 1978). There is also widespread transmission of *P. ovale* and *P. malariae* but both cause limited clinical problems.

Figure 1.1

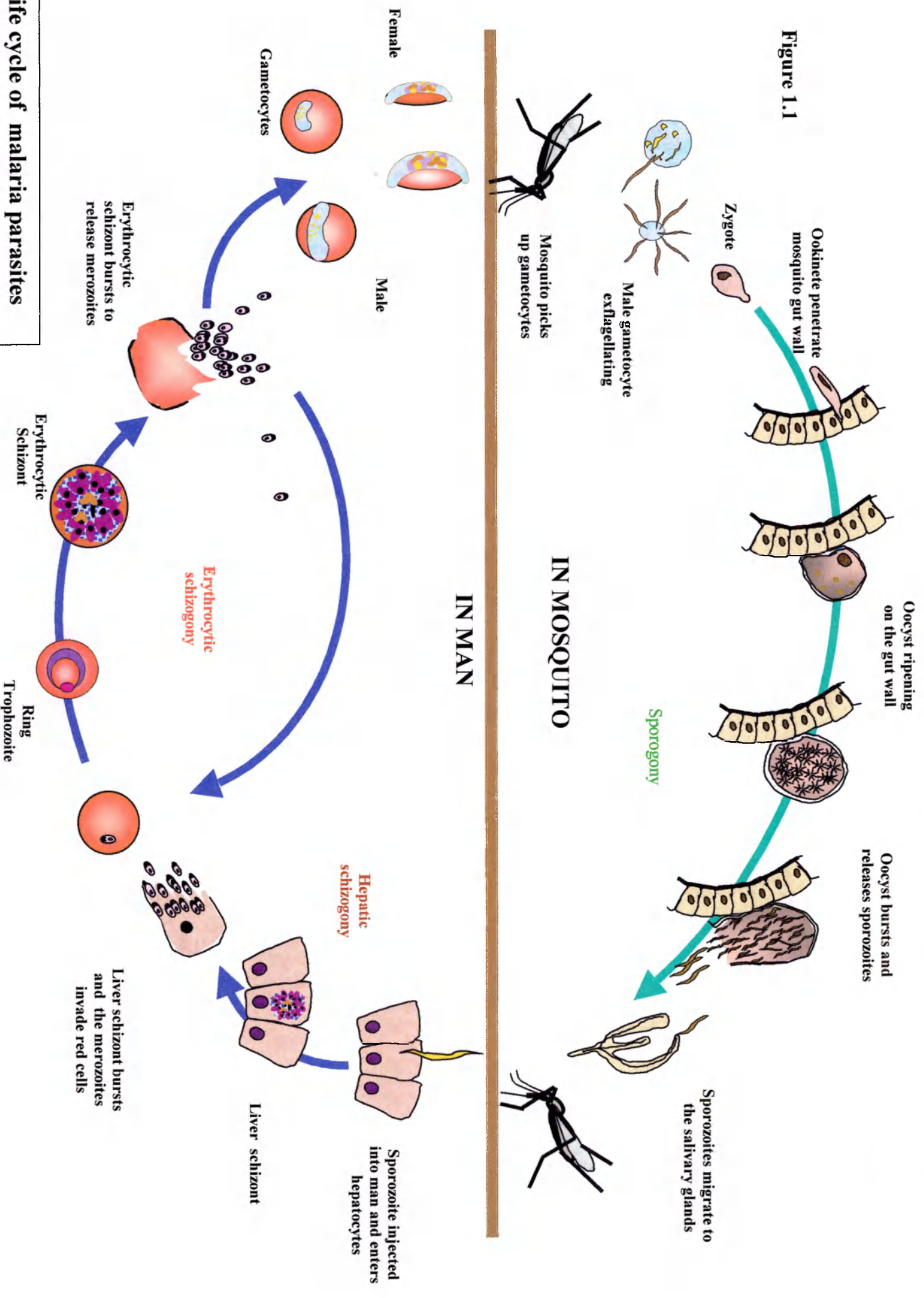

The life cycle of malaria parasites

Parameters used to measure malaria transmission

The intensity of malaria transmission in an area can be estimated by considering the proportion of the resident population that have malaria parasites or exhibit malaria-related signs such as a swollen spleen (prevalence) or the rate of new infections or disease cases (incidence). Alternatively, human-vector contact is estimated by determining the number of infected mosquito bites a person receives over a given time: entomological inoculation rate (EIR). From this parameter, the total number of secondary cases generated by a single case, i.e. the basic reproduction rate (R_0) can be estimated. Under normal circumstances R_0 is never fully achieved as many factors affect the generation of new cases, however it has many implications in terms of malaria transmission and vaccine development (Fig 1.2) (Molineux, 1988; Wernsdorfer and McGregor, 1988).

The rapid rise with age of the number of individuals who have been exposed to malaria in endemic areas has been seen as an indication that malaria has very high R_0 . The implication of this is that vaccines against malaria will need to have very high efficacy and effectiveness if they are to reduce malaria transmission. However, studies in Papua New Guinea (Forsyth, *et al.*, 1989), Kenya (Bull, *et al.*, 1998) and Gabon (Barragan, *et al.*, 1998) have shown that exposure to individual parasite variants, as reflected by rate of sero-conversion to the polymorphic antigens on the surface of red cells infected by mature stages of *P. falciparum*, actually rise relatively slowly with age. Such an age-exposure relationship suggests that individual variants of malaria parasites may have relatively low transmissibility. Thus, malaria could be seen as a construct of many independently transmitted low- R_0 variants. In which case, the apparently high R_0 of malaria might simply reflect the sum of the R_0 of the constituent variants rather high transmissibility (Gupta, *et al.*, 1994).

Mathematical modelling of malaria transmission

Ronald Ross (1911) was the first to formulate a mathematical model that attempts to quantify the relationship between malaria prevalence, vectorial capacity, recovery rate, and time. Ross's model was subsequently modified by Macdonald (1952) who incorporated terms to test the sensitivity of endemicity to changes in transmission variables (Najera, 1974). A third model that includes partial immunity was developed by Dietz during the Garki malaria control project (Dietz, *et al.*, 1974). A number of insights into the transmission of malaria that are important in the planning and evaluation of malaria control were derived from these models. First, there is a critical vectorial capacity below which malaria transmission is not sustainable (Fig. 1.2). Second, close to this point small changes in vectorial capacity can produce disproportionately large changes in prevalence. This explains why low transmission areas are prone to epidemics. Third, at higher levels of transmission, even large fluctuations in vectorial capacity have little or no effect on parasite prevalence. The corollary of this is that a drastic reduction in prevalence without alteration of vectorial capacity is followed by a rebound to the original prevalence. These models predict that short of driving vectorial capacity to the critical point, malaria control measures are bound to fail. Although some of the predictions made by these models have been proved, some of their implicit and explicit assumptions may not hold in the field. A very robust model would be required to cope with all the perturbations seen in nature (reviews by (Molineaux, 1985; Dietz, 1988; McKenzie, 2000).

The burden of malaria disease in Africa

Assessing the true burden of malaria disease in Africa is hampered by lack of data. The majority of malaria deaths occur outside hospital where they are inaccessible for recording (Snow, *et al.*, 1999). Verbal autopsies used to estimate out-of-hospital mortality have low

sensitivity and specificity (Snow, *et al.*, 1992; Quigley, *et al.*, 1996). Similarly, hospital records are often limited and of suspect reliability. Nevertheless, it is estimated that about 1 million malaria-attributable childhood deaths occur in Africa annually (Greenwood, *et al.*, 1991; WHO, 1996).

Figure 1.2

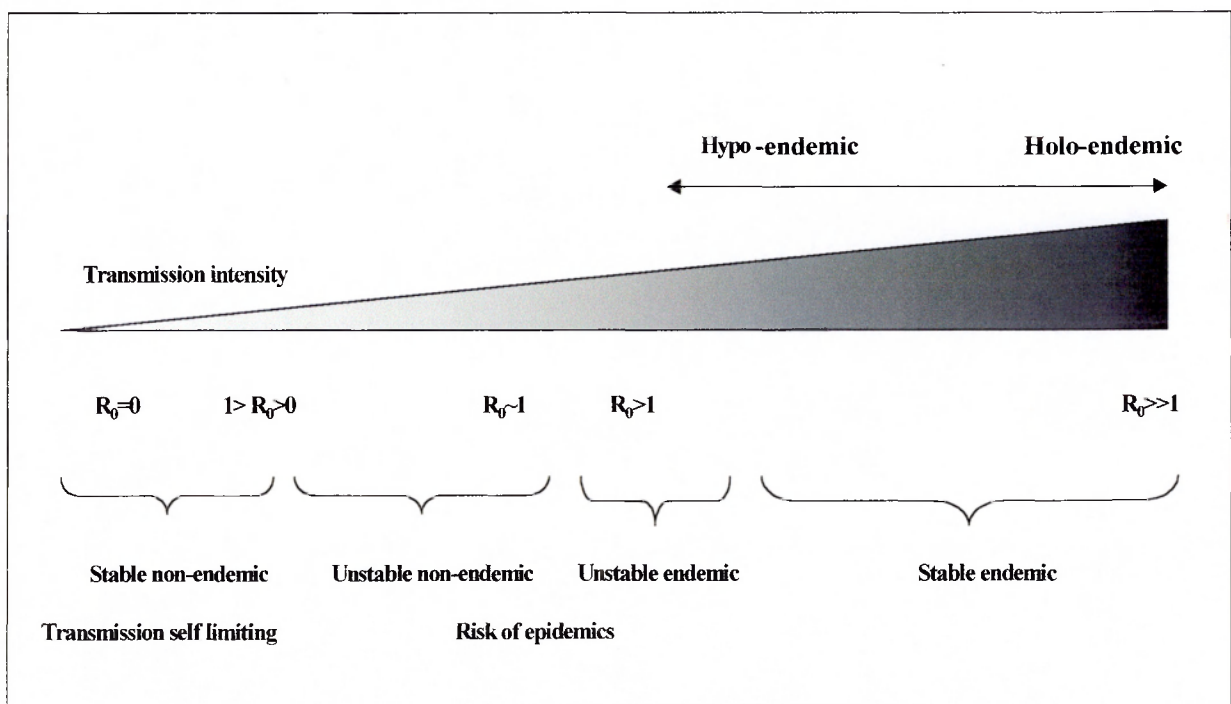

A classification of malaria transmission based on the basic reproduction rate (R_0)

(Wernsdorfer and McGregor, 1988)

A careful review by Snow *et al* (1999) of 28 prospective demographic surveillance from 12 east and west African countries yielded a median malaria mortality of 8.6 deaths per 1000 in children aged 4 years or less. Although the case-fatality of malaria appears low compared to that of some other childhood diseases, the high incidence ensures that malaria is the leading cause of childhood deaths in endemic areas (Greenberg, *et al.*, 1989; Greenwood, *et al.*, 1991; Snow, *et al.*, 1998a). Combining these malaria-specific mortality estimates with fuzzy logic models that integrate high resolution population and climatic probability models with geographic information systems (GIS) to estimate malaria risk put malaria mortality among Africa children between 0 - 4 years at between 0.43 and 0.68 million per year (Snow, *et al.*, 1996; Snow, *et al.*, 1998a; Snow, *et al.*, 1999).

The Relationship between transmission, age, and distribution of disease.

In areas of very low or unstable transmission, malaria morbidity and mortality are equally distributed among all age groups, unless if for some reason there is age-related variation in exposure. The amount of exposure to malaria parasites is not sufficient to allow the development of long-term malaria immunity. Nevertheless, a small group of people are able to maintain chronic asymptomatic infections, and those serve as a reservoir of infection (Babiker, *et al.*, 2000; Hamad, *et al.*, 2000). Under ordinary circumstances, the total burden of disease in these areas is low as the lifetime risk of disease is also low (Snow, *et al.*, 1997). However, such areas are vulnerable to malaria epidemics during which, mortality among all age groups can be extremely high if appropriate treatment is not available (Alles, *et al.*, 1998; Hay, *et al.*, 2001). Immigrants from non-endemic areas represent another group within which the risk of malaria disease is equally distributed among all age group. However, data from Irian Jaya suggest, albeit inconclusively, that older immigrants have higher initial risk of

developing severe malaria than younger ones but go on to acquire immunity more rapidly (Baird, 1995; Andersen, *et al.*, 1997; Reeder, *et al.*, 1997).

In areas where transmission is stable, malaria morbidity and mortality is concentrated in young children, becoming less frequent with age (Greenberg, *et al.*, 1989). Malaria mortality is virtually absent in adults (Fig. 1.3). This observation provides the strongest evidence that individuals develop malaria-specific immunity following repeated exposure. Infants below the age of three months are normally relatively protected from malaria by a number of mechanisms including maternal antibodies, foetal haemoglobin that is thought to be less conducive to parasite growth, and reduced contact with mosquitoes (Sehgal, *et al.*, 1989; Hogg, *et al.*, 1995; Snow, *et al.*, 1998b). This protection wanes by the fourth to sixth month of life and disease incidence increases rapidly until immunity is acquired after which it begins to decrease. Under very high transmission, disease incidence peaks in the first year of life and by their fourth year children have few and mild episodes (Bloland, *et al.*, 1999). In areas with lower transmission, the disease incidence–age curve is flattened as disease episodes are spread over a wider age range and the incidences peak occurs at a higher age (Snow, *et al.*, 1994; Modiano, *et al.*, 1999; Rogier, *et al.*, 1999b).

For reasons that are yet to be understood, severe malaria anaemia incidence peaks earlier than the incidence of cerebral malaria. In the Gambia (Marsh, 1992), in coastal Kenya (Marsh and Snow, 1997; Snow, *et al.*, 1997) and western Kenya (Bloland, *et al.*, 1999), the incidence of severe malaria anaemia peaks at 1-2 years while that of cerebral malaria peak between 2-4 years. It is possible that the smaller blood volume in children makes them more vulnerable to red cell damage and thus anaemia.

Figure 1.3

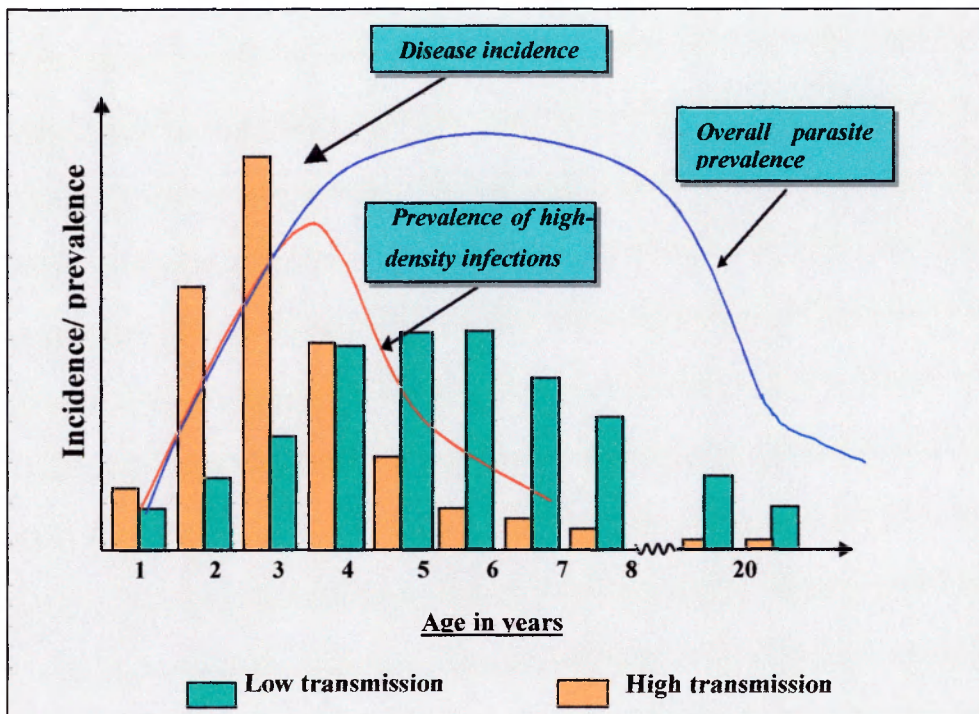

A diagrammatic representation of the relationship between age and the incidences of disease in low and high transmission areas, overall parasite prevalence and the prevalence of high density infections

On the other hand, it has been suggested there may be an immune mediated element in cerebral malaria, which requires the maturation and sensitisation of the immune system. An alternative theory is that cerebral malaria is caused by rare parasite strains and the delay in cerebral malaria simply reflects the low chance of encountering the causative strains (Gupta and Day, 1994). However, recent work by Bull *et al* (1998) suggests that parasite isolates that cause severe malaria are common with respect to the variant parasite-derived antigens expressed on surface of schizont-infected red cells (Bull, *et al.*, 1999).

The risk of severe malaria in relation to transmission intensity

Two studies by Snow and his colleagues have been instrumental in redefining our understanding of the relationship between risk of severe disease and malaria transmission. These studies showed that contrary to the previous speculations the risk of severe malaria does not continue to rise with increasing transmission but rather plateaus and may even dip slightly at very high levels. The first study compared rates of severe disease between Kilifi, Kenya, (EIR = 10-30) and Ifakara, Tanzania (EIR >300). Although both sites had similar annual rates of severe disease in children under the age of 5 years there were twice as many patients under one year of age in Ifakara compared to Kilifi. The rates of cerebral malaria and malaria anaemia were four fold higher and 3 fold lower respectively in Kilifi compared to Ifakara (Snow, *et al.*, 1994). In the second study, age specific severe malaria rates for five sites with varying transmission in Kenya and in the Gambia were estimated from hospital admission records. Kilifi North, an area of low-to moderate transmission had the highest rate while holo-endemic Siaya had the lowest (Marsh and Snow, 1997; Snow, *et al.*, 1997). Similar observations were made when disease rates in low transmission urban area in Burkina Faso were compared with those of a high transmission rural area (Modiano, *et al.*, 1998b, 1999).

In these studies by Snow *et al* (1997), the mean age of patients admitted with severe malaria decreased with increasing transmission intensity, ranging from 77 months in Bakau, which is hypo-endemic, to about 25 months in the hyper-endemic Kilifi South. A possible explanation for these observations is that in high transmission areas children encounter malaria parasites very early in life and partial protection by residual passive immunity enables them to acquire specific immunity without having to suffer severe disease. An

important question raised by these studies is whether by lowering transmission, bed nets and other control measures might increase the incidence of severe malaria disease.

In relation to transmission intensity, parasite prevalence presents a different picture from disease incidence. In most endemicity settings, the rise in prevalence is slower than that of disease incidence so that it is still rising when the peak of disease incidence is reached and continues to rise while disease incidence declines (Marsh, 1992). Eventually prevalence reaches saturation, remains constantly high, and only begins to fall much later during adulthood. The level of saturation correlates with transmission intensity although even at very low transmission, high prevalence is attained (Beier, *et al.*, 1999). Saturation is maintained by re-infection and by chronic infection. Even where disease incidence show marked seasonality, parasite prevalence remains fairly constant (Smith, *et al.*, 1993; Babiker, *et al.*, 2000). On the other hand, mean parasite density has a trend similar to that of disease with high parasite density infections occurring early in life, after which the majority of people have low-density parasitaemia (Trape, *et al.*, 1994; Bloland, *et al.*, 1999) (Fig. 1.3).

1.4 THE CLINICAL FEATURES OF MALARIA

Malaria presents as a spectrum of symptoms ranging from mild aches to a life threatening condition although only a minority of malaria case progress to become severe. Both host and parasite-related factors interact to determine the outcome of a malaria infection but the nature of many of these interactions is still poorly understood. Many of the symptoms such as fever, vomiting, and joint pains that accompany acute episodes of malaria are non-specific and are shared with other childhood diseases. Some of the important features of malaria commonly encountered in African children are discussed below (see review by (WHO, 2000)). The prevalence of these features, and mortality rates associated with them among children in Kilifi are shown in figure 1.4

Fever

Paroxysms of chills, shivering and high fever followed by sweating are common features of malaria in non-immune individuals but are less obvious in semi-immune children. In addition, fever in children is an unreliable diagnostic feature of malaria as could arise from several other infections (Smith, *et al.*, 1995b). Fever, in malaria, is thought to be mediated by tumour necrosis factor (TNF) and other pyrogenic cytokines whose release by monocytes is triggered by toxins released during schizont rupture (Picot, *et al.*, 1990; Sherry, *et al.*, 1995; Kwiatkowski, *et al.*, 1997). Although high fever causes discomfort and could precipitate convulsions during an acute malaria attack, it is not associated with risk of sequelae or death (Marsh, *et al.*, 1995; Waller, *et al.*, 1995). The finding that temperatures corresponding to fever can kill malaria parasites *in-vitro* while anti-pyretic drugs increases parasite clearance time *in-vivo* (Brandts, *et al.*, 1997) is indirect evidence that fever may be important in regulating parasitaemia. However, it is still a common practice to try and lower fever during malaria episode using antipyretic drugs, tepid sponging, and mechanical cooling.

Anaemia

While prolonged afebrile malaria infections in children may cause relatively benign chronic anaemia, acute malaria attacks can precipitate life-threatening anaemia. Severe malarial anaemia was originally defined by a haemoglobin of below 50g/l or a haematocrit > 15% in the presence of more than 10,000 malaria parasites/ul of blood but it is now recognised that there are other factors that might exacerbate anaemia even at lower parasite densities (Newton, *et al.*, 1997). The rupture of infected erythrocytes by mature parasites, cannot solely account for the profound anaemia encountered in many malaria patients (Pasvol, 1986). Increased immune haemolysis, phagocytosis (Abdalla, 1990; Yuthavong, *et al.*, 1990) and splenic clearance (Greenwood, *et al.*, 1978 ; Ho, *et al.*, 1990b) of both infected

and uninfected erythrocytes following sensitisation with IgG (Facer, 1980; Scholander, *et al.*, 1998) and complement (Waitumbi, *et al.*, 2000) and changes in deformability (Dondorp, *et al.*, 2000) have been cited as potential mechanisms. Dyserythropoiesis induced by malaria toxins and cytokines (Clark and Chaudhri, 1988; Miller, *et al.*, 1989) has also been implicated. The relative importance of each of these mechanisms is unclear at present.

Hypoglycaemia

Hypoglycaemia is a complication of acute malaria that is associated with a poor prognosis (Molyneux, *et al.*, 1989; Waller, *et al.*, 1995; Jaffar, *et al.*, 1997; Schellenberg, *et al.*, 1999). Though common, hypoglycaemia is often missed because its symptoms are easily confused with those of malaria itself. Quinine has been implicated as a possible cause of hypoglycaemia in malaria because it stimulates insulin secretion (Henquin, *et al.*, 1975; Okitolonda, *et al.*, 1987; Krishna, *et al.*, 1994). However, this is not important if quinine is administered as a slow infusion in conjunction with dextrose (Taylor, *et al.*, 1988). Hypoglycaemia in malaria is most likely attributable to a combination of fasting and increased glucose demand by the host and parasites (Davis, *et al.*, 1990; Davis, *et al.*, 1995). Depletion of glucose precursors may depress gluconeogenesis (Dekker, *et al.*, 1997a) though the evidence for this is equivocal (Dekker, *et al.*, 1997b; English, *et al.*, 1998). Other factors such as high TNF levels could also contribute to the depression of gluconeogenesis during malaria.

Respiratory Distress

Children with severe malaria sometimes exhibit laboured breathing characterised by nasal flaring, increased chest excursion, intercostal indrawing, and air hunger (Kussmaul's breathing). Though recognised as a feature of malaria only recently, respiratory distress is

one of the most important prognostic indicators in malaria (Marsh, *et al.*, 1995). Potential causes of respiratory distress include cardiac failure, co-existent pneumonia (English, *et al.*, 1996b), pulmonary oedema, sequestration of parasites in the lungs and increased central drive to respiration in association with cerebral malaria. However, the major cause of respiratory distress is lactic acidosis (English, *et al.*, 1997b). The breathing pattern observed results from attempts to compensate by blowing out CO₂. Impaired renal and hepatic function could result in pH dysregulation, but the main cause of lactic acid accumulation appears to be poor tissue perfusion due to anaemia, dehydration and obstruction of blood flow by sequestered parasites leading to hypoxia and anaerobic respiration (Davis, *et al.*, 1995). The parasite's contribution of acids is difficult to determine but it is thought to be minor. Thus, fluid replacement and blood transfusion are associated with resolution of acidosis and clinical improvement (English, *et al.*, 1997a). In a minority of children without raised lactic acid, acidosis is attributable to other metabolic acids or acids from drugs such as aspirin (salicylate) (English, *et al.*, 1996a) or herbal remedies.

Neurological involvement

Neurological involvement in malaria is signified by convulsions, impaired consciousness, abnormal posturing, and changes in muscle tone. Other features include raised intra-cranial pressure, and brain swelling. The pathogenesis of these features is discussed in detail later in this section.

Prognostic indicators in malaria

The fact that most children who die from malaria do so within 24 hours of admission to hospital, (Waller, *et al.*, 1995) necessitates the development of criteria by which children at high risk of deteriorating or dying can be rapidly identified and given priority in treatment.

Several studies have identified deep coma, respiratory distress or acidosis and hypoglycaemia either independently or together as bearing the highest risk of sequelae and death. In addition, recurrent convulsions and jaundice are also associated with poor prognosis. Conversely anaemia unless profound, and hyperpyrexia on their own carry a low risk of death (Molyneux, *et al.*, 1989; Waller, *et al.*, 1995; Jaffar, *et al.*, 1997; Schellenberg, *et al.*, 1999) (also see fig 1.4 (Marsh, *et al.*, 1995)). The proportion of mature parasite in peripheral circulation (Silamut and White, 1993) but not overall parasitaemia (Sowunmi, *et al.*, 1992) is also an important prognostic feature.

Of interest is the recent observation that decreased red cell deformability is highly predictive of death in Thai (Dondorp, *et al.*, 1997) and Kenyan (Dondorp, 1999) malaria patients. However, even in the best hospital, there is a proportion of malaria patients who will die, prompt treatment notwithstanding. Some of these may have presented too late for the damage by disease to be reversed while others may succumb to concurrent infections or poisoning by drugs and herbal remedies administered prior to hospitalisation.

The pathogenesis of cerebral malaria (CM)

Although for clinical purposes any malaria patient with impaired consciousness is considered to be severely ill and requiring urgent medical attention, for the sake of standardising reporting especially in research, the presence of unrousable coma in the absence of other encephalopathies is required to qualify the diagnosis of cerebral malaria (WHO, 2000). Despite affecting only a small percentage of malaria patients, cerebral malaria contributes significantly to malaria deaths and sequelae because of its high morbidity and mortality (Waller, *et al.*, 1995). The pathogenesis of cerebral malaria is a subject of intense debate. The matter is partly complicated by lack of a standardised definition of CM and partly by the fact

that even when the current criteria are strictly applied, coma in the patients that are defined does not necessarily have a homogenous aetiology.

Marsh *et al.*, (1996) have described four groups of CM patients. In three of the groups, coma resolves rapidly and usually without sequelae. Within the first group are children who are in coma secondary to convulsions (prolonged post ictal state) who regain consciousness once normal cortical function is restored. A second group has coma secondary to metabolic derangement including acidosis and hypoglycaemia, and resolution of coma follows the correction of these disturbances. A recently defined group are children who are comatose because they are actually having subtle seizures (status epilepticus) characterised by very mild muscle tics, nystagmoid eye movement, excessive salivation or irregular breathing and which are hard to discern except by electroencephalography (Crawley, *et al.*, 1996). These children recover consciousness rapidly upon receiving anticonvulsants. The rest of the patients defined as having CM have prolonged coma and high odds of sequelae on recovery despite treatment and supportive care (Brewster, *et al.*, 1990). In these patients, coma and seizures probably arise from primary brain lesions caused by malaria parasites. It is in this group that the evolution of symptoms is least understood and most debated.

A number of hypotheses have been put forward to try and explain the development of CM. Extrapolation of data from experimental malaria in monkey models led to some early workers suggesting that CM results primarily from cerebral oedema. They postulated that malaria toxins compromised the integrity of the blood brain barrier allowing leakage of fluid from blood vessels into the brain (Maegraith and Fletcher, 1972).

Figure 1.4

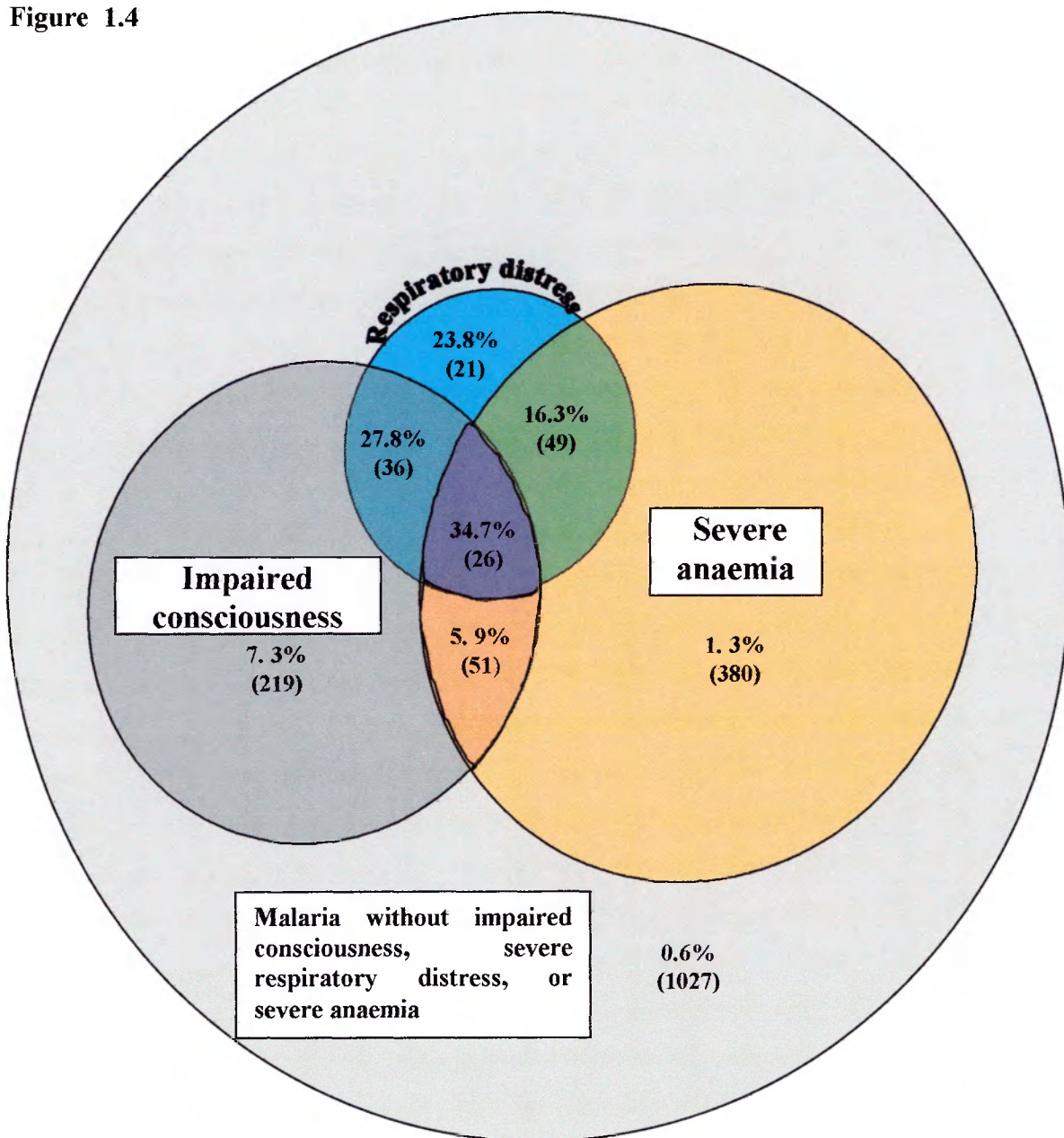

Prevalence, overlap, and mortality for major clinical subgroups of severe malaria among children in Kilifi, Kenya. Total numbers are in parentheses, and mortality is given as a percentage (adapted from Marsh et al., 1995).

Later studies suggested that macromolecules do not cross the blood brain barrier during malaria in human (Warrell, et al., 1986). CT scans indicate that the brain swelling and raised

intra-cranial pressure in CM are associated with increased cerebral blood volume and cytotoxic rather than vasogenic oedema (Newton, *et al.*, 1994). However, more recent studies indicate that CM may be accompanied by alterations in the distribution of cerebral vessels endothelial cell junction proteins and leakage of some plasma proteins into the perivascular space. It is therefore possible that functional changes of the blood brain barrier occur in CM (Brown, *et al.*, 1999).

The current explanations fall into two though not mutually exclusive hypotheses: the mechanical blockage and cytokine-mediated pathology (Grau and De-Kossodo, 1994; Mendis and Carter, 1995). The mechanical blockage hypothesis relies on the finding of a large number of parasitised erythrocytes sequestered in the cerebral vessels of patients who had died of CM but little signs of extra-vascular haemorrhagic or inflammatory pathology. (MacPherson, *et al.*, 1985; Aikawa, *et al.*, 1990; Pongponratn, *et al.*, 1991). It is therefore thought that sequestered infected red cells obstruct blood flow in cerebral capillaries and the resulting hypoxia causes ischaemia and neuronal damage (Berendt, *et al.*, 1994b). Cerebral lesions revealed by CT scans on Kenyan children with CM are consistent with a critical reduction in cerebral perfusion (Newton, *et al.*, 1991; Newton, *et al.*, 1994). Further, cerebral hypo-perfusion and decreased oxygen saturation in CM patients has been demonstrated by use of Positron emission CT (Kampf, *et al.*, 1997). In addition to sequestration of infected cells in capillary, adherence of non-infected red cells to infected cells, a phenomenon known as rosetting (Udomsangpetch, *et al.*, 1989), is also thought to contribute to vascular occlusion in CM. Parasites from CM patients have been reported to have an increased tendency to form rosettes (Treutiger, *et al.*, 1992; Ringwald, *et al.*, 1993; Rowe, *et al.*, 1995).

The mechanism underlying the binding of parasitised erythrocytes to endothelial cells and rosetting has been studied extensively (Berendt, *et al.*, 1994a; Newbold, *et al.*, 1997a). *Ex*

vivo and *in-vitro* electron microscopy has shown that the binding is largely but not exclusively restricted to knobs-like structures on the infected cell surface (Biggs, *et al.*, 1990). The knobs which consist of histidine rich proteins; HRP1 and HRP2 are thought to provide support for binding receptors, the best characterised of which is PfEMP1 (Leech, *et al.*, 1984a; Aikawa, 1988). Other proteins that might be involved in cytoadherence include rifins (Kyes, *et al.*, 1999), sequestrin (Ockenhouse, *et al.*, 1991), and altered host cell membrane proteins (Crandall, *et al.*, 1994). The list of putative endothelial cell ligands that interact with the infected cell receptors has been growing longer and longer. Most wild parasite isolates bind to CD36 (Oquendo, *et al.*, 1989), while some bind to thrombospondin (Roberts, *et al.*, 1985), ICAM-1 (Berendt, *et al.*, 1989), PECAM (Treutiger, *et al.*, 1997), ELAM (Ockenhouse, *et al.*, 1992), glycosaminoglycans, blood group antigens, (Barragan, *et al.*, 2000) and chondroitin sulphate (Fried and Duffy, 1996). During malaria attacks some ligands such as ICAM-1 are up-regulated in the brain while others such as CD36 are not (McGuire, *et al.*, 1996). Thus, it is possible that only parasites that bind to particular ligands can cause CM, which would partly explain why only a small proportion of individuals develop despite evidence that sequestration takes place in practically all malaria patients (Newbold, *et al.*, 1997b).

Proponents of the alternative hypothesis argue that obstruction of blood flow by sequestration is not sufficient to explain the pathology seen in CM. They point out that the reversibility of CM coma and low incidence of sequelae are not compatible with neuronal damage due to hypoxia (Clark and Rockett, 1994). They suggest that the symptoms are a result of a cascade of local events prompted by the obstruction rather than of the obstruction *per se*. Occlusion of capillaries can provoke local inflammatory reactions resulting in the release of cytokines such as TNF that mediate tissue damage. Both TNF- α and interferon- γ were found to be critical in

murine CM as were CD4 + T helper cells (Grau, *et al.*, 1989a; Rudin, *et al.*, 1997). However, the mouse model differs from human CM in that there is no sequestration of parasitised red cells instead the vessels are plugged by mononuclear cells and fibrin-covered red cells. Although high levels of TNF in CM patients (Grau, *et al.*, 1989b; Kern, *et al.*, 1989; Kwiatkowski, *et al.*, 1990) and the association of TNF promoter gene polymorphism with susceptibility to CM (McGuire, *et al.*, 1994) argues for TNF's role in human CM, the absence of CM in *P. vivax* infections despite high TNF levels argues that TNF levels *per se* are not the critical factor.

TNF has been proposed to exert its action through several pathways one of which is the induction of nitric oxide (NO) (Rockett, *et al.*, 1992). Although NO is normally involved in cell signalling in the body, sustained high levels of NO can inactivate neurones. Because NO is very labile, its concentration in the body can only be determined by extrapolating serum nitrate and nitrite levels. Elevated levels of both molecules were reported in CM patients in Gabon (Kremsner, *et al.*, 1996), Papua New Guinea (al-Yaman, *et al.*, 1997), and Tanzania (Anstey, *et al.*, 1997). However, correction for impaired renal excretion eliminated the elevation in the Tanzanian study suggesting that the raised nitrogen intermediaries' levels were due to retention rather than increased production of NO. Creatinine levels in the PNG patients were not suggestive of renal impairment and the original conclusion was upheld.

Clark and Cowden (1999) have attempted to reconcile the roles of TNF, NO and sequestration by suggesting that while complete obstruction of cerebral vessels could bring about irreversible brain damage, partial obstruction results in hypoxia that interacts synergistically with TNF to induce NO production. Excess induced NO subverts the normal neuronal NO feedback mechanism and inactivates the neurones. The resulting coma is

resolved without permanent damage when NO levels fall and neuronal activity is restored. They suggest that TNF on its own is not adequate to induce sufficient NO in the absence of sequestration-induced hypoxia which would explain the absence of CM in *vivax* malaria (Clark and Cowden, 1999). It is unlikely that only one mechanism is responsible for the pathogenesis of CM, it is more likely each of the above mechanisms contribute to varying degrees.

1.5 THE IMMUNOLOGY OF MALARIA

Innate and acquired immunity are important factors in determining the outcome of a malaria infection in an individual. Some genetic factors that provide innate protection against malaria have been recognized for sometime, while others have become evident only recently. Evidence for acquired malaria specific immunity is provided by the reduced incidence and severity of malaria episodes following repeated exposure.

Genetic resistance to malaria

Several genetic traits have been shown to confer resistance to malaria infection disease. However, for most traits, the mechanism underlying the protection they provide is poorly understood. The following is a brief review of genetic traits that are associated with innate immunity to malaria.

Protection against malaria by haemoglobinopathies

Haldane in 1949 was the first to hypothesize that the reason certain red cell defects have an unexpectedly high prevalence in malaria endemic areas is because protection against malaria gave heterozygotes selective advantage over non-carriers (reviewed by (Yuthavong and Wilairat, 1993; Weatherall, 1996; Weatherall, 1997)). Such protection is most evident in

sickle cell heterozygotes who enjoy over 90% protection against severe malaria (Hill, *et al.*, 1991) while homozygous sicklers often die young from a variety of infections and effects of the defect (Molineaux, *et al.*, 1979). Protection by α^+ thalassaemia, though less (60% -40%) than that by sickle cell trait, is still significant (Bienzle, *et al.*, 1972; Martin, 1994; Allen, *et al.*, 1997). A large combined case-control study in Kenya and the Gambia found 40-50% protection against severe and mild malaria in both female heterozygotes and males hemizygote G6PD deficient individuals (Ruwende, *et al.*, 1995) contrary to earlier assertions that only heterozygote G6PD deficient females were protected (Bienzle, *et al.*, 1972; Martin, 1994).

The mechanisms by which haemoglobinopathies protect against malaria are poorly understood. Decreased parasite invasion and growth, possibly due to altered membrane characteristics and physiology in abnormal cells has been reported (Senok, *et al.*, 1997a; Senok, *et al.*, 1997b). Although sickling of infected cells could physically injure the parasite or alter haemoglobin so that it is unavailable for the parasite, susceptibility of homozygote sicklers to malaria argue against this being the basis of protection in sickle cell trait (Nagel, 1990). The susceptibility of G6PD deficient and thalassaemic cells to oxidative damage has been cited as a possible explanation for their protection against malaria. Increased oxidative stress by parasites could mediate cell damage and kill the parasite in the process (Friedman, 1978, 1979; Golenser and Chevion, 1989). High potassium levels in culture media abrogate the effect of oxidants on thalassaemic and G6PD⁻ malaria cultures (Friedman, 1979). Thus, the loss of this cation from infected thalassaemic G6PD⁻ cells and sickle cells could be important in mediating parasite damage. At the same time, infected abnormal red cells exhibit reduced cytoadherence and rosetting, two phenomena that have been implicated in pathogenesis of cerebral malaria (Udomsangpetch, *et al.*, 1993; Carlson, *et al.*, 1994).

However, protection by haemoglobinopathies may not be purely passive; Increased phagocytosis of infected abnormal cells has been observed (Yuthavong, *et al.*, 1990). Acquired immunity against severe malaria disease following increased exposure to *falciparum* and *vivax* at an early age has been proposed as an explanation for the otherwise paradoxical observation by Williams *et al* (1996) that homozygous α^+ thalassaemic Vanuatu children below the age of five are actually more susceptible to mild *falciparum* and *vivax* malaria (Yuthavong and Wilairat, 1997).

The effect of MHC and other gene polymorphisms on susceptibility to malaria

Unlike haemoglobinopathies that have easily distinguishable phenotypes, other genotypes that influence responses to malaria are less discernible and only following the recent advances in molecular techniques have they been detected. The role of the MHC genes that code for Human Lymphocytes Antigens (HLA) in immunity is well established. T-cells, which are central to specific immunity, only recognise foreign antigens that are presented in conjunction with self-HLA. The T-cells can then mediate cytotoxic and inflammatory functions or stimulate B-cells to produce antibodies. It is thought that the extensive diversity of HLA evolved because of the need to recognise the very large number of potentially harmful antigens in the environment. It has been postulated that the widely observed variation in immune responses to and outcome of malaria infection in individuals in endemic areas might be associated with MHC restriction (Quakyi, *et al.*, 1989), (review by (Riley, *et al.*, 1991; Riley, 1996)).

The clearest evidence for HLA association with malaria came from a large case-control study in Gambian children where possession of the class 1 HLA-Bw53 allele provides about

40% protection against severe malarial anaemia and cerebral malaria while the class II alleles DRB1*1302 protects against severe anaemia but not cerebral malaria (Hill, *et al.*, 1992). Correlation between the geographic distribution (25-40% in West African and absent in Caucasians) of these alleles and malaria endemicity lends support to the malaria selection hypothesis. The authors suggested that since HLA is expressed on hepatocytes but not red cells, T-cytotoxic lymphocytes (CTL) protect against severe malaria by killing the parasite's liver stage. Subsequently they identified a conserved peptide from the liver-stage-specific antigen-1 (LSA-1) as the target for HLA-B53-restricted T-cells (Hill, *et al.*, 1991). Objection has been raised against this liver-stage killing hypothesis on the grounds that HLA-B53 was not associated with protection against infection in this and later studies that found HLA-B53 carriers and non-carriers to be equally susceptible to re-infection following radical cure (Carter, *et al.*, 1992; Dieye, *et al.*, 1997; Sokhna, *et al.*, 2000). It has been suggested that CTL may be involved in a non-HLA class 1-restricted protection (Kemeny, *et al.*, 1994), or that HLA-B53 may be linked to other genes that control immunity. HLA-B53 was not protective against malaria in East Africa, indicating that other genetic and environmental factors may modify the association between HLA and malaria outcome (Hill, *et al.*, 1994).

Other HLA alleles which have been reported to be involved in malaria immunity are HLA - DRB1*0301 and -* 03032 which were positively associated with levels of antibodies against Rhostry-Associated Protein 1 (RAP1) in Cameroonian children below the age of 15 years and DRB*03011 which was positively associated with antibodies to RAP2 in adults older than 30 years (Johnson, *et al.*, 2000). In Papua New Guinea, possession of class II HLA-DRB1*15 or a strongly linked HLA-DQB1*0601 was reported to negatively associated with titres of antibody to the trial vaccine SPF66. Conversely, bearers of DRB1*11 or DQB1*0301 had higher antibody titres (Beck, *et al.*, 1995b). Detecting genetic effects on a

disease requires a large sample size and it is possible that studies that failed to find any HLA association with responses to the ring stage antigen RESA/ Pf155 or the 230 and 48/45 kilodalton gametocyte antigens may have been limited by small samples size (Graves, *et al.*, 1989; Riley, *et al.*, 1990).

Besides MHC, several other genes have also been studied to determine their association with immunity to malaria. Of particular interest are TNF promoter genes and a recently discovered ICAM-1 polymorphism. So far two mutations on the TNF promoter gene that affect malaria outcome have been identified; a point mutation at position 308 that is associated with increased risk of sequelae and death in children with cerebral malaria (McGuire, *et al.*, 1994), and another mutation at position 238 that increases the risk of severe malarial anaemia (McGuire, *et al.*, 1999). The exact mechanism by which these mutations exert their effects is yet to be established, although the up-regulation of TNF leading to increased pathology has been considered. Position 238 does not seem to have role in the transcription of TNF and might be a marker for important polymorphisms elsewhere on the TNF gene. The two mutations are not linked suggesting that severe malaria anaemia and cerebral malaria are influenced by separate genetic factors linked to the TNF gene. One mechanism through which TNF is thought to promote pathology is by the induction of nitric oxide (NO). A mutation on the NO-synthase 2 (NOS2) gene that protects against severe malaria and infection has been identified by Kun *et al* (1998) in Gabonese children.

Given the potential involvement of ICAM-1 in the pathogenesis of cerebral malaria as a endothelial cell receptor for infected cells during sequestration, one would expected that natural selection in malaria areas would favour ICAM-1 mutations that were protective against severe malaria. Surprisingly, a mutation that increases susceptibility to cerebral

malaria was found at high frequencies in Kenya and other malaria endemic areas. Homozygous ICAM-1^{kilifi} is associated with a 2-fold increase in the risk of cerebral malaria relative to the wild type ICAM while heterozygote have a 1.39 relative risk (Fernandez-Reyes, *et al.*, 1997). ICAM-1^{kilifi} has a lower binding affinity for malaria infected red cells compared to the wild type ICAM-1, the reduction being more marked in low binding affinity clones than in high affinity binders. Thus it is possible that ICAM-1^{kilifi} increases susceptibility to cerebral malaria by selecting out parasites with high binding affinity leading to increased parasite sequestration and pathology.

ICAM-1^{kilifi} was not associated with disease severity in the Gambia (Bellamy, *et al.*, 1998) while in Gabon it was actually protective against anaemia (Kun, *et al.*, 1999). This may not be surprising as severe malarial anaemia, the dominant clinical syndrome in Gabon, has a different aetiology from cerebral malaria. It is difficult to envisage how a gene that increases susceptibility to cerebral malaria is maintained at high frequencies in malaria endemic areas except by the presence of a very strong balancing selection pressure. ICAM-1 is known to be the binding receptor for Human Rhinovirus (HRV) that causes common cold (Craig and Berendt, 1991). Although HRV do not cause mortality, they might have been more virulent in the past thus lowered affinity for HRV or other pathogens in ICAM-1^{kilifi} could have counter balanced the increased in susceptibility to severe malaria.

Further evidence of the genetic control of immunity to malaria comes from population, twins, and family pedigree studies (Taylor-Robinson and Philips, 1993; Hill, 1997). In a study among sympatric ethnic groups in West Africa, the Fulani had different parasite prevalence, malaria antibodies titres and allelic profiles of genes involved in malaria outcome compared with the Mossi and Rimaibe. Permethrin impregnated nets had a higher

impact on parasite rates among the Fulani than in the other two groups (Modiano, *et al.*, 1998a). A segregation analysis of blood infection levels among 44 Cameroonian families was consistent with a complex genetic control of malaria immunity that is not inherited in a Mendelian manner (Garcia, *et al.*, 1998) Another family study in Burkina Faso identified a region of the short arm of chromosomes 5 that is associated with the control of parasitaemia. This region has genes that are implicated in the regulation of immune responses including cytokines IL-3 IL-,4, IL-12, and macrophage stimulating factors (Rihet, *et al.*, 1999). It is clear from these studies that genetic associations in malaria are very complex and a lot remains to be known. Hopefully, the recently completed sequencing of the human genome will provide an opportunity for the rapid identification of other genes involved in malaria .

Acquired immunity

Despite years of research, surprisingly little progress has been made in unravelling the mechanisms underlying immunity to malaria. Decreasing frequency and severity of malaria episodes with age are the best indicators of acquisition of immunity (Fig. 1.3) but defining an individual's immune status at a given time is extremely difficult. Many *in-vitro* measures of immunity in malaria simply reflect exposure but do not correlate with *in-vivo* protection (Hoffman, *et al.*, 1987; Marsh, *et al.*, 1989; Thelu, *et al.*, 1991). Furthermore, there are no fully appropriate *falciparum* malaria models from which data could be reliably extrapolated to man. Disentangling protective responses from non-protective ones in the complex milieu of responses provoked by malaria parasites is a major objective in many studies (Marsh, 1992; Miller, *et al.*, 1997). A "Unified theory" of malaria immunity is yet to be established but several models have been proposed.

Anti-Parasite and anti disease immunity

The observation that parasite prevalence continue to rise long after disease incidence has fallen led to the idea that immunity to malaria develops in two phases. Anti-disease immunity, which controls disease symptoms and allows individuals to remain asymptomatic despite having parasites, is acquired first (Sowunmi, *et al.*, 1992; Karunaweera, *et al.*, 1998; Vounatsou, *et al.*, 2000) while immunity against parasitisation develops later. This two-phase paradigm is supported by data from malariatherapy records. Practised in the mid 20th century, malariatherapy involved deliberately infecting syphilis patients with malaria on the premise that the fever induced by malaria would kill syphilis spirochetes. In most patients, fever and high parasitaemia occurred in the first 25 days after which a low-density asymptomatic infection persisted for many months. This suggests that “anti-disease” responses set in earlier than anti-parasite immunity (Collins and Jeffery, 1999b). In reality, these two phases are poorly distinguished and must overlap to a large extent otherwise anti-disease immunity acting in the absence of anti-parasite immunity would not prevent the parasites from multiplying and eventually overwhelming the patient, albeit asymptotically. It is likely that the two types of immunity probably share the underlying mechanisms (Rogier, *et al.*, 1999a). For example, since the risk of disease is proportional to parasitaemia (Rougemont, *et al.*, 1991; Smith, *et al.*, 1994), immune mechanisms that clear parasites are also likely to reduce the risk of disease.

The disquisition of “original antigenic sin” hypothesis in malaria

An alternative outlook is that the same mechanisms that kill parasites also cause disease, and immune status reflects a balance between protection and immuno-pathology. T-cells from people without prior exposure to malaria are known to respond well to some malaria antigens, possibly because of prior sensitisation by cross-reactive antigens in the environment

(Chizzolini, *et al.*, 1990; Good, 1994b; Troye-Blomberg, 1994; Riley, 1999). However, many of these responses are not protective against malaria. Thus, in non-immune individuals, skewing of responses towards previously encountered cross-reactive antigens in accordance with the 'original antigenic sin' paradigm (Fazekas de St and Webster, 1966; Kohler, *et al.*, 1994) could prevent protective malaria-specific responses (Good, *et al.*, 1993) but still provoke immuno-pathology. Good *et al* (1995) have suggested that the acquisition of immunity to malaria might involve the elimination or tolerization of such pre-sensitised T-cells (Good, 1995). The possession of a larger repertoire of cross-reactive T-cells might help explain why non-immune adults appear to have more severe malaria episodes on their initial encounters with malaria parasites compared to equally non-immune children (Baird, 1995; Riley, 1999).

Premunition in malaria

Individuals who are immune to malaria do not necessarily have a complete resistance to infection, instead they are able to tolerate and maintain chronic infections at very low parasite densities (Marsh, 1992; Smith, *et al.*, 1993). It has been speculated that chronic infections are in themselves protective against super-infection. This kind of immunity was designated "Premunition" by Sergent and Parrot (1935). Work done in animal models suggests that premunition may be species- and strain-specific. The importance of chronic infections in premunition has been demonstrated in squirrel monkey - *P. Knowlesi* model where eradicating chronic infections by chemotherapy abrogated protection against super-infections. However, some degree of immunity persisted for sometime after the cure (Sinton, 1939; Singh and Singh, 1940). Studies in Tanzania (Smith, *et al.*, 1999) and Papua New Guinea (Al-Yaman, *et al.*, 1997a), suggest that in humans, premunition against malaria is related to the multiplicity of clones in the established infection rather than the infection *per*

se. Clonicity of an infection is determined with respect to the number of allelic variants of polymorphic antigens such as MSA-1, MSA-2, and GLURP present. In a longitudinal study among children in Kilifi, being parasitaemic at the beginning of a follow-up period was only associated with protection against subsequent episodes of severe malaria in children who also had agglutinating antibodies to certain parasite isolates at that time. The possession of the agglutinating antibodies was not independently associated with protection while being parasitaemic alone was independently associated with increased susceptibility to subsequent severe disease episodes (Bull *et al.*, in prep.)

Despite the fact that the idea of premunition in malaria was first mooted in the early part of the 20th century, to date, little is understood of the underlying mechanism. Because splenectomy abrogates the ability to maintain chronic infections in animal models (Contamin, *et al.*, 2000), it has been suggested that activated macrophages in the reticulo-endothelial system of the spleen might be important in the maintenance of low parasite densities in chronic infections and in preventing super-infection (Sinton, 1939; Weiss, *et al.*, 1986). Such a proposal is consistent with the antibody-dependent cellular inhibition (ADCI) mechanism of maintaining chronic infections proposed by Druihle and Perignon (1997) discussed in fuller details later in this section. Because this mechanism is parasite density dependent, an increase in the number of merozoites, as might be caused by a super-infection, would result in increased production of ring stage inhibitors by macrophages and consequently the suppression of the super-infecting parasites population. However, ADCI is not clone-specific and therefore does not sufficiently account for the association between premunition and the multiplicity of the chronic infections and with the possession of variant-specific agglutination antibodies. Possibly premunition involves a synergistic interaction between non-variant specific mechanisms, including ADCI, and variant-specific mechanisms directed against

polymorphic antigens such as those that are targets for agglutination antibodies. In such a scenario, parasites bearing antigen variants that are homologous to those on the parasites causing the chronic infection would be stopped from re-infecting the host. Thus, a wider repertoire of clones in the chronic infection would give a wide cover against super-infection by the locally circulating variants. The observation by Bull (2001) in the study cited above that children who were parasitaemic at the beginning of the study also agglutinated a larger number of isolates compared to those who were not, lends further support to this hypothesis.

The strain transmission theory and development of immunity to malaria

It has been suggested that malaria is transmitted as a construct of many independent “strains” and that one needs to accumulate immunity to each of the strains before they are wholly immune to malaria (Gupta and Day, 1994). An observation in malariatherapy that point to the strain specificity of malaria immunity. The observation during malariatherapy that previous infections gave considerably more protection from re-infection by a homologous, than by a heterologous strain (Jeffery, 1966; Collins and Jeffery, 1999a) is evidence for strain-specific immunity

Unlike in the laboratory where strains can be physically separated, it is difficult to imagine how such a population structure could be sustained in the field despite sexual mixing (Ranford-Cartwright, *et al.*, 1993; Babiker, *et al.*, 1994; Hill and Babiker, 1995). However, using mathematical models, Gupta *et al* (1999) have shown that efficient immunity directed against a polymorphic antigenic determinant could constrain parasite populations into discrete non-overlapping strains with respect to that antigen (Gupta and Day, 1994; Dye, 1996; Gupta and Anderson, 1999; Gupta, *et al.*, 1999b).

Polymorphism is a common feature of many malaria antigens and is generated through recombination during fertilization and/or clonal antigenic variation (Anders and Smythe, 1989; Borst, *et al.*, 1995). The circumsporozoite protein (CSP) (Dame, *et al.*, 1984; Lockyer, *et al.*, 1989) and thrombospondin-related adhesive protein (TRAP) (Robson, *et al.*, 1998) on the surface of sporozoites all have regions of extensive polymorphism as does the major merozoite antigens; merozoite surface proteins (MSP-1 & MSP-2) (Cooper, 1993; Felger, *et al.*, 1994), ring stage erythrocyte surface antigen (RESA) (Perlmann, *et al.*, 1984) and the apical membrane antigen-1 (AMA-1) (Verra and Hughes, 1999). The parasite-induced erythrocyte surface antigens (PIESA) inserted by mature parasites on to the surface of the host red cells, examples of which are PfEMP1 and rifins, also exhibit extensive polymorphism (see section 1.5). The location of T-cell epitopes in the polymorphic regions of some of these malaria antigens, and the preponderance of non-synonymous mutations in these regions suggest that the regions may be under immune selection pressure (Favaloro, *et al.*, 1986; Anders and Smythe, 1989; Lockyer, *et al.*, 1989; Hughes and Hughes, 1995; Verra and Hughes, 1999)

Responses against PIESA are an example of immunity that might be sufficiently efficient to structure malaria parasite population into "strains" (for a detailed review see section 1.5). These antigens are highly polymorphic and undergo clonal antigenic variation (Roberts, *et al.*, 1992; Brannan, *et al.*, 1994). Antibodies to PIESA provide variant-specific protection against malaria (Marsh, *et al.*, 1989; Newbold, *et al.*, 1992; Bull, *et al.*, 1998; Bull, *et al.*, 1999). It is thought that the variation of these antigens serve as a parasite immune evasion mechanism and therefore the need to avoid the generation of cross-reactive responses would provide the selection pressure necessary to maintain distinct variants. The number of PIESA variants against which an individual has antibodies increases with age (Iqbal, *et al.*, 1993;

Reeder, *et al.*, 1994; Bull, *et al.*, 1998). Thus, acquisition of immunity to malaria might involve the accumulation of antibodies against the circulating repertoire of PIESA variants.

Also emerging from models proposed by the same research group is the hypothesis that contrary to classical thinking, immunity to severe disease may develop after only one or two episodes of disease (Gupta, *et al.*, 1999a; Gupta, *et al.*, 1999b). However, in a study in the Gambia, children who had severe malaria did not differ from controls in their ability to agglutinate randomly selected parasite isolates suggesting that they had had similar past malaria exposure (Erunkulu, *et al.*, 1992). A model based on the finding that parasite variants that caused severe disease were more commonly agglutinated than those causing mild disease has been proposed by Bull *et al.*, (1999). In this model there is a gradual trade off between virulence on the one hand and immunogenicity on the other. Virulent variants carry more immunogenic antigens and are thus more commonly recognised by antibodies from a malaria endemic population while benign variants have less immunogenic antigen phenotype (Bull, *et al.*, 1999). It is not clear if immunity to severe disease operates independent of immunity to mild malaria.

Persistence of acquired immunity to malaria

There is a serious dearth of data on the persistence of malaria immunity. The susceptibility of residents in low seasonal transmission areas to repeated infection suggests that any immunity they develop during the infections is short-lived in the absence of continuous exposure. In addition, the loss of agglutinating antibodies within a period of 4 months has been reported (Giha, *et al.*, 1998). However, during the recent malaria epidemics in the Madagascan highlands, some adults were partially protected against clinical malaria despite a thirty-year lapse since their last infection (Deloron and Chougnet, 1992). Furthermore,

immigrants from endemic areas to Italy who returned to their native countries after a number of years suffered milder malaria episodes and had lower parasitaemia than Italian visitors (Di Perri, *et al.*, 1994; Di Perri, *et al.*, 1995). These two reports suggest that an important degree of immunity to malaria may last longer than was previously thought.

Immune effector mechanisms in malaria immunity

The question of which immune mechanism are effective against malaria parasites is not any more clearer than that of how immunity develops. The relative importance of the cellular and humoral arms of the immune system in protection against malaria is not yet well established. This is partly due to lack of data in humans and partly because their relative importance varies markedly in different no-human models.

T-cells.

Humans T-cells can be divided into two main groups depending on their surface markers and the class of HLA that they interact with. CD4⁺ T-cells, which are restricted by class II HLA, provide help to B-cells and other effector cells, and as such are also referred to as T-helper cells. On the other hand, CD8⁺ T-cells, which interact with class I HLA, are also referred as cytotoxic T-cells (CTL) because they kill infected cells by various means. There is also a minor subset of T-cells that express $\gamma\delta$ receptors rather than $\alpha\beta$ receptors, and whose interaction with MHC is still uncertain. Roles for these three T-cell subsets in immunity to malaria have been described through either indirect observation in humans or in animal models. The caveat here is that many animals in which studies of malaria immunity have been carried out are poor models of human malaria.

CD8+ T-cells (CTL)

Because hepatocytes express class 1 HLA, the liver stage of malaria parasites is thought to be capable of inducing CTL responses. The role of CTL in the protection against malaria was first demonstrated in the classical experiments involving the immunization of animals and human with irradiated sporozoites. Such immunization resulted in complete, though short-lived, immunity (Rieckmann, *et al.*, 1974; Clyde, 1975). Adoptive transfer and depletion experiments in animals showed that although high levels of anti-sporozoite antibodies were observed in the immunized subjects, the protection observed was mediated by CTL (Schofield, *et al.*, 1987; Suss, *et al.*, 1988; Weiss, *et al.*, 1988). The fact that adoptively transferred CTL pre-primed with *P. berghei* failed to protect against infection by *P. yoelii* indicates that protection by CTL is species-specific (Romero, *et al.*, 1989). Indirect evidence for CTL protection against malaria in humans is borne in the association between some class 1 HLA alleles and protection against malaria (Hill, *et al.*, 1991). Over 30 peptides on the sporozoites and liver stage antigens of malaria parasites have now been identified as epitopes for human CTL (Aidoo, *et al.*, 1995; Bottius, *et al.*, 1996; Aidoo and Udhayakumar, 2000). Some of these epitopes exhibit extensive polymorphism generated by non-synonymous mutations, an indication that they are under some sort of selection possibly by host immunity (Lockyer, *et al.*, 1989; Schofield, 1989; Hughes and Hughes, 1995).

CTL could kill parasites by perforin-mediated lysis, FAS-induced apoptosis of infected cells (Kagi, *et al.*, 1994; Lowin, *et al.*, 1994), or via a cytokine pathway in which IFN- γ stimulates the host cell to kill the parasites through nitric oxide production. The importance of the cytokine pathway has been demonstrated in mice (Schofield, *et al.*, 1987) but the contribution of the other mechanisms remains unclear.

Although naturally infected individuals show relatively poor responses to circumsporozoite protein (CSP) and the liver stage specific antigen (LSA) possibly because of low numbers of sporozoites in mosquito inocula and the lack of CTL co-stimulatory signals on hepatocytes (Aidoo, *et al.*, 1995), it might be possible to boost these responses using a vaccine (Hoffman and Franke, 1994). Irradiated sporozoites, though strongly immunizing, (Rieckmann, *et al.*, 1974; Clyde, 1975) are impractical for large-scale vaccination thus the need to identify specific CTL epitopes in malaria antigens. Several peptides that are putative epitopes for CTL have been shown to provide effective immunization in animal models (Romero, *et al.*, 1989; Bottius, *et al.*, 1996). An important part of CTL vaccine design is the vehicle for delivery. Both naked DNA coding for CSP (Sedegah, *et al.*, 1994; Wang, *et al.*, 1998) and live vectors such as recombinant *Salmonella typhimurium* (Aggarwal, *et al.*, 1990), and influenza or vaccinia viruses (Rodrigues, *et al.*, 1994) have been used successfully in experimental immunization. The potential hazard of live vectors could be avoided by using recombinant yeast-Ty virus-like particle expressing CS epitopes that have been shown to produce impressive levels of CTL activation in mice, (Gilbert, *et al.*, 1997).

A promising recent development in CTL-based vaccinology is the prime-boost technique that involves priming a subject with naked plasmid DNA coding for the target antigen and later boosting the responses with the target antigen borne on a different carrier such as Modified Vaccinia Virus, or Fowlpox Virus. This technique has been shown to provoke strong CTL responses in animal models (Sedegah, *et al.*, 1998; Gilbert, *et al.*, 1999) and this forms the basis for the ongoing studies on the possibility of using the technique against human malaria. Two concerns in CTL vaccines that require consideration are the polymorphic nature of some CTL epitopes that might restrict the number of people responding to a particular vaccine construct (Good, 1994a ; Aidoo and Udhayakumar, 2000)

and the mutual inhibition of CTL responses by variants of the same epitope (Gilbert, *et al.*, 1998; Plebanski, *et al.*, 1999). The first problem could be circumvented by the use of multivalent vaccines (Doolan, *et al.*, 1996), while the second can only be resolved by experimentally determining which epitopes might be mutually antagonistic.

CD4+ T-cells.

Traditionally mature CD4+ T-cells are placed in two groups that are associated with distinct cytokine profiles. Production of interferon alpha/gama (INF- α/γ), lymphotoxin- α (TNF- β), interleukin-12 (IL-12) defines type 1 helper cells (TH1) and is associated with a strong cell-mediated immunity while production of IL-4, 5, 6, 9, 10 and 13 define type 2 (TH2) which is associated with antibody production. However, because some T-cells and non-T-cells can produce both TH1 and TH2 cytokines, it may be more appropriate to talk of a type 1 (TR1) or a type 2 response (TR2) (Clerici and Shearer, 1994). In malaria, the TR1/TR2 dichotomy is most clearly seen in the mouse-*P. chabaudi* model. In this model, TR1 dominates the early response of mice to acute *P. chabaudi* infection and parasite killing is mediated by INF- γ , tumour necrosis factor (TNF- α) and nitric oxide (NO) secreted by activated TH1 CD4+, macrophages, and natural killer cells. TR1 cytokines - NO, INF- γ and TNF- α are also thought to mediate disease symptoms. On the other hand, a shift towards TR2 leads to less symptomatic chronic infections. Along with inhibiting both INF- γ and TNF- α , type 2 cytokines also stimulate B-cells to secrete of antibodies (Taylor-Robinson, 1995; Pretolani and Goldman, 1997; Fell and Smith, 1998). The dual anti-parasite/ pathogenetic nature of TR1 is also evident in *P. berghei* infections (Rudin, *et al.*, 1997; Hirunpetcharat, *et al.*, 1999). Other murine-malaria models display variable tendencies towards either type of responses during acute and chronic infections (Taylor-Robinson and Smith, 1999).

The distinction between type 1 and 2 responses is less clear in human malaria. Increased IFN- γ is associated with the resolution of parasitaemia in acute malaria episodes (Winkler, *et al.*, 1998) and a delay in re-infection (Luty, *et al.*, 1999), while reduced levels accompany hyper-parasitaemia in children (Winkler, *et al.*, 1999). IFN- γ levels were also found to be higher in pregnant women who did not have placental malaria than in those who did (Moore, *et al.*, 1999). These observations argue for a possible anti-parasite role of TR1 in humans. On the other hand, IL-10 and IL-4, both type 2 cytokines, have been associated with protection against malarial anaemia (Kurtzhal, *et al.*, 1998; Biemba, *et al.*, 2000). Although reduced secretion of IFN- γ by immune T-cells in response to malaria led to the conclusion that reduced pathology in immune individuals may be attributable to down-regulation of TR1 cytokines (Chizzolini, *et al.*, 1990), Winkler *et al.* (1999) observed a striking increase in type 1 cytokines in immune adults (Winkler, *et al.*, 1999). It is likely that efficient immunity to malaria requires a balance between TR1 and TR2. The effect of HIV infection, which selectively destroys CD4+ cells, (Rosenberg and Fauci, 1990) on malaria is still not well established. Although some studies suggest that HIV infection is not associated with increased malaria morbidity or mortality (Migot, *et al.*, 1996; Chandramohan and Greenwood, 1998), others suggest the converse might be true especially in HIV patients with advanced decline in CD4+ counts (Whitworth, *et al.*, 2000) and in HIV-positive pregnant women (Steketee, *et al.*, 1996). Taken together these observations suggest that in less advanced stages of HIV infections, other mechanisms may compensate the loss of CD4+ T-cells in the maintenance of malaria immunity (Butcher, 1992,).

$\gamma\delta$ T-cells

In healthy individuals, the majority of T-cells receptors are made up of α and β chains, however a minority of T- cells, whose MHC restriction is uncertain, express receptors made

of γ and δ chains. Infection with malaria causes a marked increase in the proportion of $\gamma\delta$ T-cells (Ho, *et al.*, 1990a; Goodier, *et al.*, 1992) but the significance of this phenomenon is yet to be established. Most of the work that indicate a role for $\gamma\delta$ T-cells in resistance to malaria is based on mice that had immunological disruptions (Tsuji, *et al.*, 1994; Langhorne, 1996; Yanez, *et al.*, 1999) and may not necessarily reflect the situation in immunologically intact mice or human. Nonetheless, there is evidence that $\gamma\delta$ T-cells from both malaria immune and non-immune individuals can produce INF- γ , TNF- α , and LT- α in response to malaria antigens. Thus $\gamma\delta$ T-cells might be involved in early type 1 reactions in acute malaria infections (Ho, *et al.*, 1990a; Goodier, *et al.*, 1992; Ferrick, *et al.*, 1995; Pichyangkul, *et al.*, 1997; Waterfall, *et al.*, 1998; McKenna, *et al.*, 2000).

Humoral responses in malaria

There is no doubt that humoral responses are important in protection against malaria. Evidence for *in-vivo* protection against malaria by antibodies comes from passive transfer experiments both in animal models (Groux and Gysin, 1990) and humans. Passive transfer of immunity to malaria in man was first demonstrated in a series of experiments carried out in the early 1960s by Cohen, Macgregor, and Carrington. In these experiments, intramuscular administration of purified gamma globulins from malaria immune African adults into Gambian and East African children suffering from severe malaria caused a marked drop in parasitaemia within five days. Gamma globulins from Europeans without prior exposure to malaria did not show the parasitocidal effect, indicating that the antibodies from Africans were malaria-specific (Cohen, *et al.*, 1961; McGregor, 1963). In addition, Edozien *et al* (1962) showed that antibodies that protected against malaria could be obtained from cord blood thus demonstrating the maternal transfer of anti-malaria antibodies (Edozien, *et al.*, 1962). More recently, Sabchareon *et al* (1991) repeated these experiments in Thai malaria

patients who they treated with intravenous IgG from malaria immune African adults. A marked drop in parasitaemia within 24 hours of treatment was observed in all the 8 patients (Sabchareon, *et al.*, 1991; Druilhe and al, 1997). The faster rate of response in the Thai experiments compared to those observed in the earlier ones is probably due to the different route of administration of the antibodies.

In-vitro, antibodies from immune individuals have been shown to inhibit sporozoites invasion of hepatocytes (Fidock, *et al.*, 1997; Pasquetto, *et al.*, 1997), prevent merozoites invasion of red blood cells (Vande Waa, *et al.*, 1984), depress parasite growth (Mitchell, *et al.*, 1976; Brown and Smalley, 1980; Flyg, *et al.*, 1997), and promote parasite phagocytosis by macrophages (Druilhe and Khusmith, 1987; Groux, *et al.*, 1990). In addition, immune serum can disrupt rosetting (Carlson, *et al.*, 1990; Wahlgren, *et al.*, 1990; Treutiger, *et al.*, 1992) and the binding of infected erythrocytes to endothelial cell ligands (Udeinya, *et al.*, 1983; Iqbal, *et al.*, 1993; Ricke, *et al.*, 2000); two process that are implicated in the pathogenesis of severe malaria. However, it is not clear how these *in-vitro* activities correlate with effector mechanisms *in-vivo*.

Despite the evidence cited, the malaria literature is replete with reports of lack of a correlation between total antibody titres and malaria protection (Marsh, *et al.*, 1989; Thelu, *et al.*, 1991; Erunkulu, *et al.*, 1992). The majority of malaria antibodies are probably directed against cellular debris released when schizonts burst and are of little consequence. However, even antibodies against antigens that are deemed to be important for parasite survival often do not correlate with protection (Hoffman, *et al.*, 1987). There are several reasons why this could be. The immuno-dominant regions of many malaria antigens consist of tandem amino acid repeats, altering the number of which is an easy way to generate polymorphisms that

may help the parasite escape immune recognition (Anders and Smythe, 1989; Lockyer, *et al.*, 1989; Day and Marsh, 1991). At the same time, polymeric antigens can cross-link B-cell antigen receptors and induce T-cell independent antibody production that is characterised by IgM dominance and poor affinity maturation and memory cells induction. Besides being short-lived and ineffective, T-cell independent responses can also thwart protective responses to adjacent critical epitopes through epitopic inhibition (Schofield, 1991).

Under a variety of *in-vitro* situations, malaria antibodies are often ineffective against parasites in the absence of effector cells and may even promote parasite growth (Shi, *et al.*, 1999). Despite exhibiting potent anti-parasitic activity *in-vivo*, the antibodies used in the transfer experiments in Thailand showed no activity *in-vitro* except in presence of monocytes (Bouharoun-Tayoun, *et al.*, 1990; Sabchareon, *et al.*, 1991). Conversely, antibodies that do not protect *in-vivo* were unable to interact with monocytes *in-vitro* (Groux and Gysin, 1990). Thus the ability of antibodies to co-operate with effector cells may be more important than their quantity (Bouharoun Tayoun and Druilhe, 1992). It has been noted that humoral responses to malaria show pronounced skewing towards cytophilic antibodies IgG1 and IgG3, unlike responses to other pathogens where IgG1 and IgG2 dominate (Ferrante and Rzepczyk, 1997). This bias has been reported severally in responses against ring-infected erythrocyte surface antigen (RESA) (Dubois, *et al.*, 1993; Beck, *et al.*, 1995a), merozoites surface antigens (MSA1/2) (Taylor, *et al.*, 1995; Rzepczyk, *et al.*, 1997) and schizont antigens (Thelu, *et al.*, 1991; Nguer, *et al.*, 1997; Piper, *et al.*, 1999b).

This skew towards cytophilic antibodies that need to bind to effector cells before they can mediate any action against antigens could explain the failure of malaria antibodies to exert anti-parasitic activity on their own. *In-vitro* work has shown that while cytophilic antibodies

cooperate with monocytes in inhibiting parasites, non-cytophilic subclasses antagonise this cooperation. Data from field studies indicate that young children and non-immune adults have a high proportion of non-cytophilic antibodies (Wahlgren, *et al.*, 1983), while cytophilic antibodies are associated with protection against infection (Salimonu, *et al.*, 1982; Aribot, *et al.*, 1996; Ferreira, *et al.*, 1996) and better prognosis during acute malaria episodes (Sarthou, *et al.*, 1997). Taken together, these data suggests that acquisition of immunity to malaria may involve a shift in responses from non-cytophilic to cytophilic antibodies (Bouharoun Tayoun and Druilhe, 1992).

An interesting observation in the transfer experiments was the failure of passively transferred antibodies to completely eradicate all the parasites. This may have parallels in the failure of otherwise highly immune individuals to eliminate chronic low-grade infections. One proposal is that the parasites that escaped the transferred immunity comprised “strains” of parasites against which the antibodies lacked specificity. Two arguments against this are that the antibodies from immune African adults are expected to be directed against multiple antigens, which should help overcome restriction, by the strain-specificity of responses to some of the antigens, and more importantly, the same antibodies were subsequently shown to be effective against the breakthrough parasites. Druilhe and Perignon (1997) have proposed a density dependent mechanism to account for the observations above (Druilhe and Perignon, 1997). They have coined the term antibody dependent cellular inhibition (ADCI), for a proposed cytophilic antibody-mediated interaction between monocytes and merozoites that cause the monocytes to release mediators that reversibly inhibit the growth of parasite ring stages. The amount of inhibiting mediators released is proportional to the ratio of merozoites to monocytes, which explains why the drop in parasitaemia following injection of immune IgG was proportional to the initial parasitaemia. Decline of either antibody levels, or numbers of

monocytes or merozoites reverses inhibition and the parasite population flares up. A further implication of the hypothesis is that since the inhibiting mediators are non-specific, this mechanism does not select for particular parasite variants. However, the huge in drop parasitaemia seen in the transfer experiment is more consistent with a parasitocidal rather than the parasitostatic effect implied by ADCI and other antibody-mediated mechanisms cannot be excluded.

Malaria antigens that are targets for immune response.

At each stage of their human cycle, malaria parasites present to the host antigens that are potential targets for immune responses. Some of the antigens from each stage that are well characterised are indicated in figure 1.5. It is hoped that the sequencing of the malaria genome will facilitate even more rapid identification of potentially important antigens. Due to limitation on space and the focus of this thesis, I will only describe briefly some the major merozoite antigens and then provide a more detailed review of the variant antigens inserted onto the surface of infected red blood cells by mature stages of malaria parasites.

Merozoite surface Proteins 1

MSP-1 and MSP-2 are the best characterised antigens on the surface of merozoites. MSP-1 consists of 17 blocks; 7 highly polymorphic blocks interspersed with 10 conserved and semi-conserved blocks. Despite the polymorphisms, there is sufficient homology between sequences of MSP1 from different parasite isolates to allow the distinction of two allelic families; K1 and MAD20, in all the blocks except in block 2 where three allelic families; K1, MAD20 and RO33 are recognised. MSP-1 is initially synthesized as a high molecular weight precursor (195 kDa) that subsequently undergoes proteolytic processing to yield fragments of 83, 42, 36, 28 - 30, and 19 kDa (reviewed by (Cooper, 1993; Holder, 1994).

The exact function of MSP-1 is not yet defined but it is thought to be involved in the binding to and invasion of erythrocytes by merozoites (Cowman, *et al.*, 2000).

Merozoites are briefly accessible to the host immune system between schizont rupture and the invasion of a new red cell and are thus possible targets for protective immunity. Although immune responses to the 83 kDa and 42 kDa fragments (Fruh, *et al.*, 1991; Riley, *et al.*, 1992; Tolle, *et al.*, 1993) and also to block 2 (Conway, *et al.*, 2000) have been shown to be associated with protection against natural infections in West African children, the most effective responses against MSP-1 appear to be directed at the 19 kDa carboxy-terminal fragment (MSP-1₁₉). *In vitro*, antibodies against this fragment can inhibit merozoite invasion of red cells (Egan, *et al.*, 1999) while immunization of mice with the *P. yoelii* equivalent of this region protect them against challenge infections by the same species. (Daly and Long, 1993) Epidemiological studies indicate that levels of anti-MSP-1₁₉ antibodies are in strongly correlated with protection against clinical malaria among Sierra Leonian (Egan, *et al.*, 1996), and Gambian children (Riley, *et al.*, 1992; Shai, *et al.*, 1995) and also among Kenyan children and pregnant women (Branch, *et al.*, 1998). Studies in Kenya and Senegal suggest cytophilic antibodies responses to these targets may be particularly important (Shi, *et al.*, 1996; Nguer, *et al.*, 1997).

Merozoite Surface Protein-2 (MSP-2)

MSP-2 is a 42 KD protein that exist as two allelic families: 3D7/CAMP and FC27. The protein has five blocks, with relatively conserved blocks 2 and 4 flanking an allele-defining variable block 3. For some unexplained reason, parasites bearing alleles of the FC27 family have been reported to be associated with increased severity of malaria episodes (Engelbrecht, *et al.*, 1995; Al-Yaman, *et al.*, 1997b). Evidence for the protective role of

responses against MSP-2 comes from both experimental work in animals and also immunology-epidemiology studies. Mice immunized with conserved regions of *P. falciparum* MSP-2 were protected against challenge infection by both *P. falciparum* and *P. chabaudi*. (Saul, *et al.*, 1992). Studies in West Africa (Taylor, *et al.*, 1998), Papua New Guinea, (Al-Yaman, *et al.*, 1997b) and Solomon islands (Rzepczyk, *et al.*, 1997) have demonstrated decreased risk and severity of clinical malaria among individuals who had antibodies against MSP-2. A skew towards cytophilic antibodies similar to that observed in the case of responses to anti-MSP-1 has also been observed in anti-MSP-2 response (Taylor, *et al.*, 1995; Rzepczyk, *et al.*, 1997).

Figure 1.5

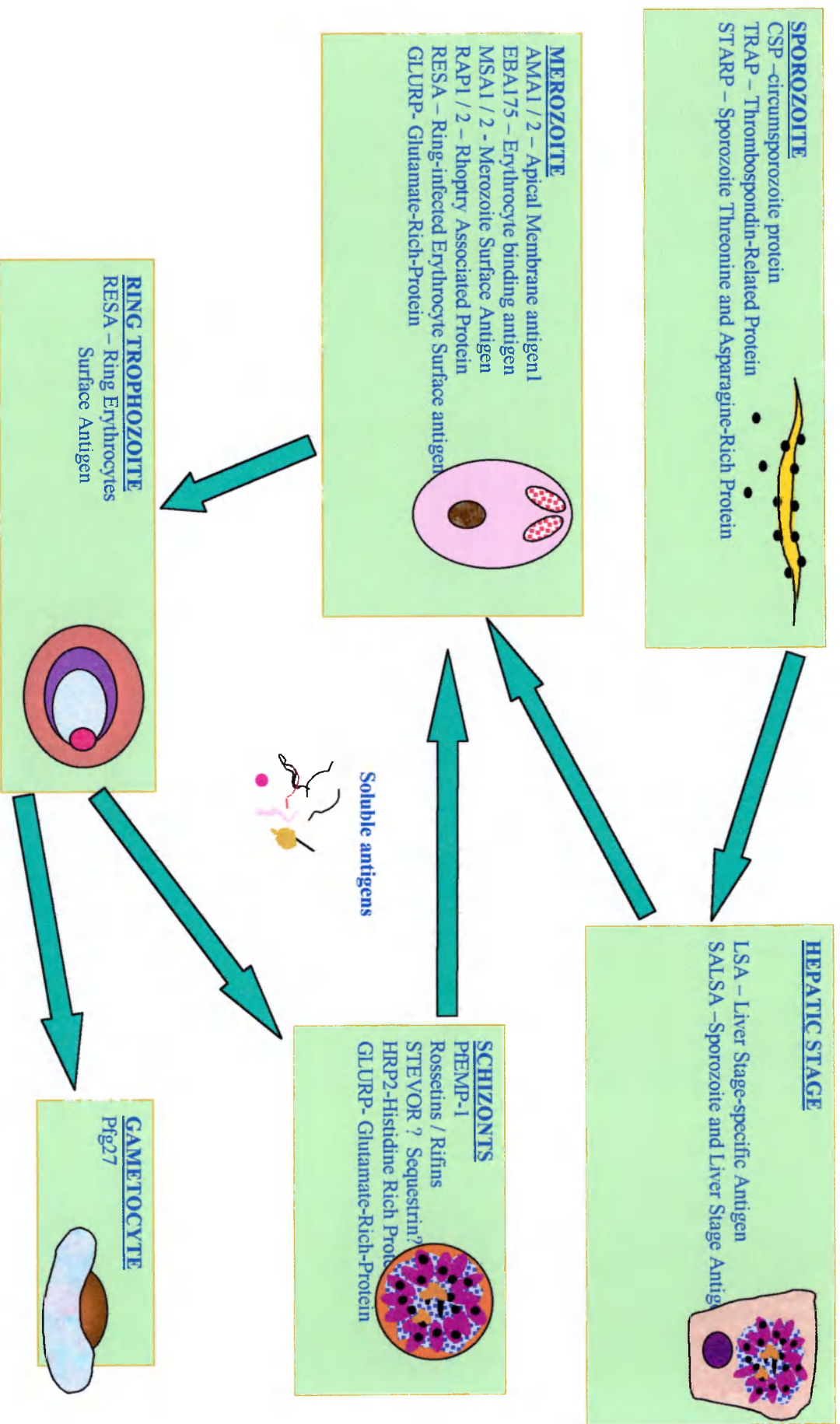

Antigens associated with various stages of malaria parasites that might be targets for the host immune responses

Apical Membrane Antigen –1 (AMA-1)

P. falciparum AMA-1 is an 83 kDa antigen that appears to originate from the apical end of the merozoite and is then transported to its surface. The identification of AMA-1 as a potential target for malaria responses is based mainly on work on its homologues in animal malaria parasites. Monoclonal antibodies against PK66, which is a 66kDa *P. knowlesi* homologue of AMA-1, inhibits merozoite invasion of red cells. In addition, immunization of rhesus monkeys with PK66 provided strong protection against challenge infection (Deans, *et al.*, 1982; Deans, *et al.*, 1988). *P. fragile* AMA-1 coupled with a Monatinide ISA 720 adjuvant has also been shown to provide squirrel monkeys with protection against *P. fragile* and also *P. falciparum* infection (Collins, *et al.*, 1994). There is evidence that humans also respond to AMA-1 and a high (94%) age-related prevalence of anti-AMA-1 antibody levels was observed in Guinea-Bissau. Similarly high prevalence was observed in Senegal although the age trend was absent (Thomas, *et al.*, 1994). Although the antibodies were not associated with decreased infection or clinical severity, analysis of the polymorphic region of this antigens revealed a preponderance for non-synonymous mutations suggesting that the region might be under some selection pressure from the host immune system (Verra and Hughes, 1999). AMA-1 is a constituent of NYVAC-Pf7, a multivalent vaccine, which was shown to be safe and immunogenic in man. However, this vaccine did not protect a group of 35 volunteers from challenge infections. (Ockenhouse, *et al.*, 1998).

Rhoptry associated proteins-1/2 (RAP-1/2)

RAP-1 and 2 are proteins with a relatively conserved amino acid sequence. RAP-1 is processed into 86, 82, 70, and 67 kDa polypeptides that then form complexes with RAP-2 or RAP-3. The complex is expelled from the rhoptries during invasion and carried through to the parasitophorus vacuoles with the merozoites (Ridley, *et al.*, 1990b). These proteins are thought to be involved the invasion of red cells, although gene knockout experiments suggest

that parasites can still invade red cell even after the disruption of RAP-1 (Cowman, *et al.*, 2000). Monoclonal antibodies against RAP-1/2 are able to stop erythrocyte invasion *in-vitro* (Schofield, *et al.*, 1986). Furthermore, Immunisation with RAP-1/RAP-2 protects Saimiri monkeys from a lethal challenge of *P. falciparum* (Ridley, *et al.*, 1990a). The results of studies involving several areas with different malaria endemicity showed that the prevalence of anti-RAP-1 IgG and IgM antibodies increase with increasing endemicity and is associated with chronic or acute infections but not protection against malaria (Jakobsen, *et al.*, 1997).

Ring stage erythrocytes surface antigen (RESA)

RESA is a 155kDa protein that is expressed on the interior side of infected erythrocytes shortly after merozoites invasion. It can be detected in this location by modified indirect immunofluorescence assay (Perlmann, *et al.*, 1984). Structurally, RESA consist of two regions of tandem amino acid repeats that contain both T-cell and B-cell epitopes (Favaloro, *et al.*, 1986). Anti-RESA antibodies are able to stop reinvasion of erythrocytes by merozoites *In-vitro* (Wahlin, *et al.*, 1984; Wahlin Flyg, *et al.*, 1999). Passive immunization with human anti-RESA antibodies (Berzins, *et al.*, 1991) and active immunization with recombinant RESA (Collins, *et al.*, 1986; Collins, *et al.*, 1988) protects Aotus monkeys against challenge infections. However, several studies in humans have reported either no correlation or a negative correlation between anti-RESA antibody titres and protection against malaria (Wahlgren, *et al.*, 1986; Chougnet, *et al.*, 1990; Dubois, *et al.*, 1993). On the other hand, Beck *et al* (1995) reported that while total anti-RESA antibody titres were not correlated with protection, the levels of cytophilic antibody (IgG1 and IgG3) were. However, a recombinant vaccine containing RESA along with two merozoites antigens failed to provide any protection against parasites in 12 human volunteers (Lawrence, *et al.*, 2000).

Antigens on the surface of malaria schizont–infected erythrocytes

Our current knowledge of the parasite-induced variant antigens on the surface of malaria-infected erythrocytes has emerged from studies on three phenomena that initially seemed unrelated: 1) the isolate-specific agglutination of schizont-infected erythrocytes by sera from malaria immune hosts. 2) The attenuation of parasite virulence through repeated passaging in splenectomized animals and 3) the absence of mature forms of malaria parasites in peripheral blood circulation.

Eaton (1938) was first to demonstrate that sera from Rhesus monkey that were immune to *P. knowlesi* agglutinated erythrocytes bearing *P. knowlesi* schizonts while sera from non-immune monkeys did not. The immune sera did not however agglutinate uninfected erythrocytes or erythrocytes containing immature stages suggesting that a new antigen was being expressed on the surface of the schizont bearing erythrocytes. Subsequently, Brown *et al* (1965) observed that during chronic malaria infections, sera obtained prior to a recrudescence peak did not agglutinate parasites associated with the peak while sera obtained after the peak did. These observations suggested that the recrudescence corresponded with the emergence of parasites with novel antigenic determinants against which the host had no agglutinating antibodies and raised the possibility that malaria parasites undergo antigenic variation similar to that seen in trypanosomes. The antigens in *P. knowlesi* that are targets for the agglutinating antibodies were eventually isolated and characterised by Howard *et al* in 1983. These antigens, designated SICA (Schizont-Infected Cells Agglutination) have a molecular mass of 180–210 kDa, were accessible to lactoperoxidase radio-iodination, insoluble in non-ionic detergent such as Triton X-100 but soluble in sodium dodecyl sulphate (SDS) and could be immunoprecipitated by malaria immune sera.

In the course of working with malaria animal models, it was observed that repeated passaging of parasites through splenectomised animals resulted in the parasite becoming progressively less virulent. For example, *P. cynomolgi* parasites isolated from splenectomised Rhesus monkeys either failed to establish a patent infection or produced relatively low parasitaemia in intact animals (Schmidt, *et al.*, 1987). A relationship between virulence and the expression of SICA antigens was established in several studies which reported that passaging parasites through splenectomised animals attenuated not only their virulence but also their agglutinating capacity (Barnwell, *et al.*, 1982; Biggs, 1991 #608; Gilks, *et al.*, 1990). The parasite used in these studies were cloned, indicating that the changes described above reflected antigenic variation rather than simply the selection of parasites with a particular phenotype from a mixed population. Consequently, it was shown that the spleen and the presence of specific antibodies were essential in the expression and variation of the SICA antigen (Barnwell, *et al.*, 1983a; David, *et al.*, 1983; Fandeur, *et al.*, 1995)

Third, it has been known for sometime now that in some malaria infections including those of *P. falciparum* in human, mature parasites are absent in the peripheral circulation as they sequester in the capillaries of organs such as the heart (Luse and Miller, 1971), liver (Gilks, *et al.*, 1990), and brain (Aikawa, 1988). Sequestration is thought to contribute to malaria pathology by occluding blood flow in the affected organs while helping the parasite avoid splenic clearance. Erythrocytes bearing mature parasites attach to endothelial cells by knob-like protrusions on the surface (Rudzinska and Trager, 1968; Luse and Miller, 1971; Kilejian, 1979; MacPherson, *et al.*, 1985). Some of the proteins that are associated with knobs have a bias for histidine in their amino acid constitution and were therefore designated knob-associated histidine-rich-protein (KAHRP) (Leech, *et al.*, 1984a). Reduced cytoadherence observed in parasites that have lost the KAHRP genes through either spontaneous chromosomal truncation during culturing (Biggs, *et al.*, 1989) or targeted disruption (Crabb,

et al., 1997) confirmed the importance of knobs in cytoadherence. In addition, Nakamura *et al.* (1992) have demonstrated that parasite receptors for the endothelial cell adhesive ligands CD36 and thrombospondin are restricted to knobs. However, the lack of an extra-cellular domain and fact that some knob-bearing parasites fail to cytoadhere (Aley, *et al.*, 1984; Rock, *et al.*, 1988) while on the converse some knob-negative parasite exhibit cytoadherence (Crabb, *et al.*, 1997) suggest that expression of KAHRP is not sufficient for cytoadherence. Other proteins found in the knobs that do not directly mediate cytoadherence but may be important in maintaining the integrity of knobs include PfEMP2 (Lustigman, *et al.*, 1990) and PFEMP3 (Van Schravendijk, *et al.*, 1993; Waterkeyn, *et al.*, 2000).

In-vitro models of infected red cells cytoadherence to endothelial cells have been developed using melanoma cells (C32), human umbilical vein endothelial cells (HUVEC), and other transformed cell lines (Udeinya, *et al.*, 1981; Marsh, *et al.*, 1988; Udeinya, 1990). That sequestration is related to spleen-induced antigenic variation was deduced from the fact that splenectomy abrogated *in-vivo* sequestration of mature parasite while *in-vitro*, parasites passaged through splenectomised monkeys failed to bind to melanoma cells (David, *et al.*, 1983). Similar observation was made in a murine-*P. chabaudi* model (Gilks, *et al.*, 1990) and in splenectomized malaria patients (Looareesuwan, *et al.*, 1993).

Endothelial cell ligands for cytoadherence

Thrombospondin (TSP), a 420 kDa glycoprotein synthesised by platelets and other adherent cells such as macrophages was the first to be identified as a receptor for cytoadherence. Infected erythrocytes were shown to adhere to a plastic surface adsorbed with TSP but not with other adhesive glycoproteins such as fibronectin and laminin. Adhesion to adsorbed TSP correlated with binding to C32 melanoma cells and could be reversed by anti-TSP antibodies (Roberts, *et al.*, 1985). However, there were reasons to believe that TSP was not the only

cytoadherence receptor (Sherwood, *et al.*, 1989). There is compelling evidence that CD36 is a cytoadherence receptor. Infected cells adhere to CD36 immobilised on plastic and this adherence can be inhibited by the monoclonal anti-CD36 antibody: OKM5. Cytoadherence to C32 melanoma cells is also inhibited by OKM5 (Panton, *et al.*, 1987; Barnwell, *et al.*, 1989). Binding of infected red cell to Simian COS cells transfected with cDNA is reversible by anti-CD36 antibodies (Oquendo, *et al.*, 1989). However, the absence of CD36 in brain capillaries, (Aikawa, 1988) the lack of correlation between CD36 binding and disease severity (Marsh, *et al.*, 1988; Ho, *et al.*, 1991) and the fact that some binding was insensitive to both anti-CD36 and Anti-TSP antibodies led to the search of an alternative cytoadherence receptor.

By screening COS cells transfected with cDNA for various adhesion molecules, Berendt *et al* (1989) demonstrated that intercellular adhesion molecule 1 (ICAM-1) is also a cytoadherence receptor for some parasite lines (Berendt, *et al.*, 1989). ICAM-1 is considered a potential mediator of sequestration in cerebral malaria because of its presence in cerebral vessels and its up-regulation by malaria cytokines (Willimann, *et al.*, 1995; McGuire, *et al.*, 1996; Newbold, *et al.*, 1997b; Kaul, *et al.*, 1998). Cytoadherence to CD36 and ICAM-1 differ in that the former causes a static arrest of infected cells, while the latter allows the infected cells to continue rolling on the adhesive molecules. Thus cytoadherence *in-vivo* may involve synergy between the two molecules (Cooke, *et al.*, 1994; McCormick, *et al.*, 1997; Udomsangpetch, *et al.*, 1997).

Other putative ligands for cytoadherence include CD31/PECAM (Treutiger, *et al.*, 1997), glycosaminoglycans, blood group antigens (Barragan, *et al.*, 2000), thrombomodulin (Rogerson, *et al.*, 1997), complement receptor-1, (CR1) (Rowe, *et al.*, 1997) and CSA (Fried and Duffy, 1996, Reeder, 1999 #576) (review by (Coppel, *et al.*, 1998)). The last receptor is

of particular interest as its expression is up regulated in the placenta and also parasites that bind CSA do not bind CD36 (Rogerson, 1995; Fried and Duffy, 1996). It has been suggested that selection of previously unencountered CSA-binding parasites in the placenta might explain the increased incidence of malaria during pregnancy in otherwise malaria immune women (Bray and Sinden, 1979; Maubert, *et al.*, 2000; Ricke, *et al.*, 2000).

PfEMP1

Some of the knob associated antigens that are directly involved in cytoadherence in *P. falciparum* were identified by Leech *et al* in 1984 (Leech, *et al.*, 1984b) who described proteins of parasite origin with a molecular weight of 260 kDa – 350 kDa and properties similar to those of *P. knowlesi* SICA antigens, i.e. they were accessible to lactoperoxidase-catalysed radio-iodination of infected erythrocytes and the radio-iodinated proteins were cleaved by low concentrations of trypsin; they were immuno-precipitated in a strain-specific manner by immune sera that also blocked cytoadherence of the source cells in a strain-specific fashion; finally the proteins were insoluble in non-ionic detergents such as Triton X-100 but soluble in SDS. These proteins, which are expressed on the infected erythrocytes surface 18 – 48 hours after invasion, were named *Plasmodium falciparum* erythrocytes membrane protein 1 (PfEMP1).

Var genes

The genes that code for PfEMP1 remained inaccessible until 1995 when their discovery was simultaneously published by three research groups. Su *et al.*,(1995) identified the genes while using Yeast artificial chromosomes (YACs) to map a segment of chromosome 7 that is linked to chloroquine resistance and designated them *var*. By screening the genomic DNA expression library of MC parasites with anti-PfEMP1 serum, Baruch *et al.*,(1995) identified cDNA that coded for PfEMP1, while Smith *et al* (1995) showed that expression of the

putative genes in a given parasite clone correlates with the expression of clone-specific PfEMP1. Each parasite is estimated to have approximately 50 *var* genes located mainly in the sub-telomeric regions of chromosomes (Fig. 1.6A). Though very diverse, these genes have a similar basic structure consisting of two exons. The first exon codes for multiple extra-cellular domains that are homologous to the cystein-rich domains of *P. falciparum* erythrocyte binding antigens (EBA175) (Rodriguez, *et al.*, 2000) and the *P. knowlesi* duffy binding proteins (DABP) (Adams, *et al.*, 1992) and have therefore been termed Duffy binding-like domains (DBL). A short trans-membrane region precedes the second exon coding for a conserved sub-membrane acidic terminal segment (ATS) that probably anchors PfEMP1 in the knob (Voigt, *et al.*, 2000).

The first extra cellular domain (DBL1) is relatively conserved and is adjacent to another conserved region, the cystein-rich inter-domain region (CIDR) (Smith, *et al.*, 2000b). Conservation of these two regions is suggestive of functional constraint and in fact the two have been shown to be the binding sites for CD36, PECAM/CD31, blood group antigens and glycosaminoglycans (Baruch, *et al.*, 1997; Chen, *et al.*, 1998a; Smith, *et al.*, 1998; Chen, *et al.*, 2000). PfEMP1 from different parasites isolates have different number of extra-cellular domains and this appears to influence the isolates' binding phenotype so that while ICAM-1-binding A4*var* (Gene ID 3540145) has five DBL and two CIDR domains (Fig. 1.6B), FCR3 *var* CSA (Gene ID 6165411) has seven DBL domains and one CIDR (Smith, *et al.*, 2000b).

PfEMP1 is an infected erythrocytes receptor for vascular endothelial cells ligands

There is overwhelming evidence that PfEMP1 is indeed a receptor for a number of endothelial cells adhesive ligands. Gardner *et al* (1996) reported that treatment of schizont-infected erythrocytes with V8 proteases and trypsin abrogated the binding of parasite clones A4, C9, and C18 to ICAM-1 and CD36-coated plates respectively. This suggested that the

binding is mediated by a receptor with characteristics similar to those of PfEMP1, i.e. protease-sensitivity. In addition, the differential sensitivity of the binding of each clone to proteases corresponded with the expression of a different variant of PfEMP1. These observations provided strong evidence that PfEMP1 binds to CD36 and ICAM-1 and also that these two ligands bind to different parts of this PfEMP1. Further evidence for the role of PfEMP1 in binding was provided in studies by Baruch *et al* (1996). They showed that affinity purification of detergent extracts of radio-iodinated infected cells using CD36, ICAM-1, and TSP yields proteins with all the properties of PfEMP1. The binding phenotype of the purified proteins corresponded with the binding phenotype of the infected cells from which they were extracted. Furthermore, trypsinization of intact PRBC yield protein fragments that bound specifically to CD36 and TSP. Pre-adsorption of the infected erythrocytes with antibodies against CD36 or TSP markedly reduced the binding of the purified proteins. Taken together these data confirmed that PfEMP1 is the parasitised erythrocyte receptor for CD36, TSP, and ICAM-1 (Baruch, *et al.*, 1996).

Examination of the binding characteristics of different DBL domains of PfEMP1 expressed in mammalian cell lines identified the relatively conserved CIDR as the binding site for CD36 (Smith, *et al.*, 1998; Chen, *et al.*, 2000) while the binding sites for CD31/PECAM, blood group antigens, glycosaminoglycans and non-immune IgM were located on DBL1 (Chen, *et al.*, 2000). DBL-2 and the C2 domain were shown to mediate binding to ICAM in parasite of the A4 clone (Smith, *et al.*, 2000a) while DBL3 and 7 mediate the binding to CSA (Buffet, *et al.*, 1999).

Figure 1.6A

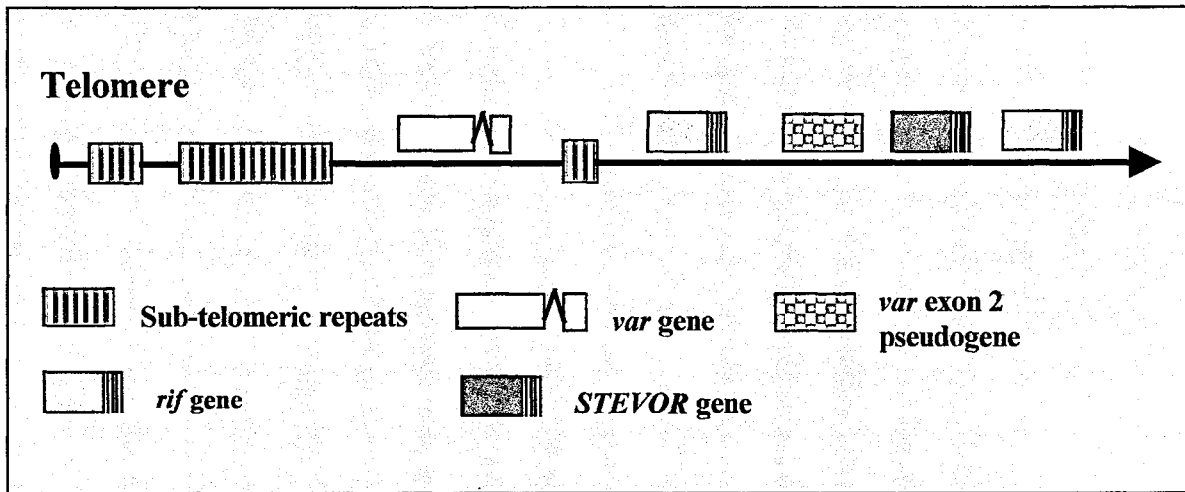

A schematic diagram of *P. falciparum* telomere based on the published clone 3D7 chromosome 3 sequence showing the location of genes that are potentially involved in cytoadherence

Figure 1.6B

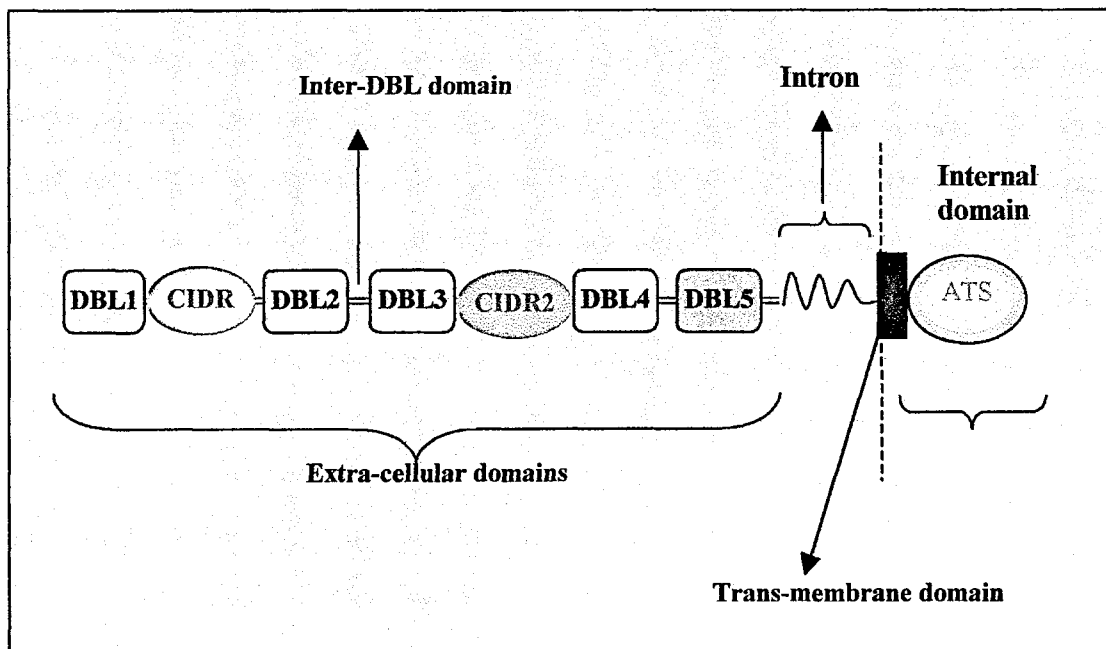

A schematic diagram of A4var gene domain organization showing the Duffy-like (DBL) domains and two cysteine-rich inter-domain regions (CIDR)

In addition, recombinant proteins containing PfEMP1 DBL1 were found to adhere to un-infected erythrocytes, disrupt naturally formed rosettes and prevent rosette formation and also bind to heparin sulphate matrix suggesting that rosette formation may involve interaction between PfEMP1 and a heparan sulphate-like molecule on the un-infected red cell surface (Chen, *et al.*, 1998a).

Other Antigens on the surface malaria-schizont infected red cells

The isolation of sequestrin, a protein with similar properties to PfEMP1, except for solubility in Triton X-100, as a putative parasite receptor for endothelial cell ligands (Ockenhouse, *et al.*, 1991) gave the hint that besides PfEMP1 there were other antigens on the surface of infected red cells (Fig. 1.7). Recently, rifins, which are highly polymorphic, low molecular mass (20-40 KDa), radio-iodinatable, SDS-soluble, Triton x-100 insoluble proteins that are expressed 14-16 hours after parasite invasion were identified (Kyes, *et al.*, 1999). Rifins have characteristics similar to those of rosettins described earlier on by Helmby *et al* (1993) and Walgren *et al* (1994) as the putative parasite receptors for un-infected red cell in rosettes and it is likely that the two protein families are synonymous. Each parasite has over 200 copies of *rif* genes clustered in the sub-telomeric regions of its chromosomes (Bowman, *et al.*, 1999; Gardner, *et al.*, 1999) and may be able to express more than one copy at a time.

Rifins are less sensitive to cleavage by trypsin than PfEMP1 and one study has suggested that agglutination seen in trypsinized infected cell may reflect rifins-mediated agglutination (Fernandez, *et al.*, 1999). However, trypsin-resistant PfEMP1-mediated agglutination has been reported previously (Gardner, *et al.*, 1996). Second, there is data to suggest that increasing concentrations of trypsin cleave PfEMP1 in a progressive manner, beginning from the N-terminus so that even at a concentration of 100 ul/ml a part of the extra-cellular

domains that could mediate some agglutination remain (Fagan, 1999). Third, Kyes *et al* (1999) were unable to immuno-precipitate rifins using pooled malaria immune sera. Thus, the evidence for rifins-mediated agglutination is equivocal.

STEVOR belong to a multi-gene family that is closely related to *rif genes*. Like *rif genes* they are located at the telomeres and have two exons of sizes similar to those of *rif genes*. To date, the location and function of the products of *STEVOR* genes have not yet been established but the predicted proteins appears to have three trans-membrane regions suggesting the presence of an extra-cellular loop (Cheng, *et al.*, 1998, Horrocks, 2000 #614).

Previous work has shown that loss of cytoadherence to melanoma cells during prolonged *in-vitro* culturing of malaria parasites is associated with deletion of the right arm of the parasites chromosome 9 (Kemp, *et al.*, 1992; Day, *et al.*, 1993; Bourke, *et al.*, 1996). Using positional cloning, Gardiner *et al* 2000) located a gene on this chromosome that is involved in maintaining cytoadherence to melanoma cells. Ablation of cytoadherence following targeted disruption or inhibition with anti-sense RNA of the cytoadherence-linked asexual gene (*CLAG9*) confirmed its involvement in cytoadherence (Trenholme, *et al.*, 2000). *CLAG9* proteins are yet to be isolated but the predicted structure has four putative trans-membrane sequences suggestive of the presence of extra-cellular domains. (see also review by (Cooke, *et al.*, 2000)

Figure 1.7

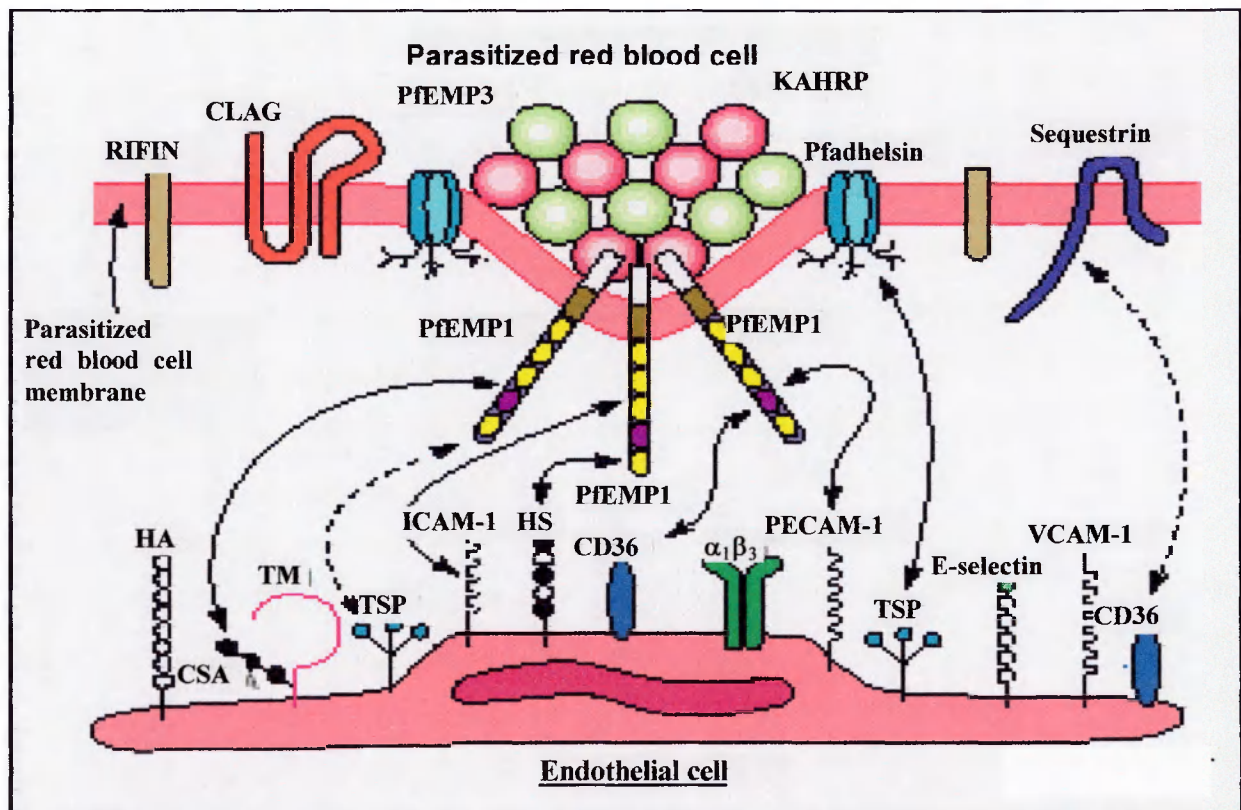

Schematic representation of the molecules implicated in the cyto-adhesive interaction between red cells and vascular endothelial cells or syncytiotrophoblasts. A region of a PRBC membrane incorporating a characteristic knob-like protuberance formed by the deposition parasite-encoded proteins such as KAHRP and PfEMP1 under the membrane skeleton of the PRBC is shown. The solid arrows indicate interactions that have been unequivocally confirmed while the broken arrows are interactions for which there is less compelling evidence or the binding membranes have not precisely mapped. Abbreviations: $\alpha_1\beta_3$ – integrins; CLAG - cytoadherence-linked asexual gene; CRI - complement receptor 1; CSA - chondroitin sulphate A; HA - hyaluronic acid; HS - heparan sulphate; ICAM-1 - intercellular adhesion molecule 1; KAHRP - knob-associated histidine rich protein; PECAM-1- platelet-endothelial cell adhesion molecule1, PfAdhelsin - modified native red cell band 3 protein; TM - thrombomodulin; TSP - thrombospondin; and VCAM-1 - vascular cell adhesion molecule 1

(adapted from Parasitology Today 2000. vol 16. pg 417)

The mechanism of antigenic variation

The most common way to demonstrate the variation over space and time of the antigens on the surface of schizont-infected erythrocytes has been by agglutination assays. By examining the agglutination of both field and laboratory- adapted parasites isolate by a panel of sera from people who are semi-immune, several studies have established that these antigens are extremely diverse and rarely are two isolates found that share similar agglutination profiles (Marsh, *et al.*, 1986; Forsyth, *et al.*, 1989; Aguiar, *et al.*, 1992; Reeder, *et al.*, 1994). This lack of cross-reactivity between isolates is also revealed in the low rate of mixed agglutination observed between isolates (Newbold, *et al.*, 1992). Although other antigens besides PfEMP1 have been found on the surface of schizont-infected, their role in agglutination is not very well established, on the other hand several pieces of evidence suggest that PfEMP1 is a major target for agglutinating antibodies: the correlation between changes in *var* genes and with changes in agglutination phenotype (Smith, *et al.*, 1995a); the correlation between sensitivity of a given PfEMP1 variant to trypsin digestion and ability of trypsin to abrogate agglutination of the source cells (Gardner, *et al.*, 1996) and the change in parasites agglutination phenotype following selection on endothelial receptors such as ICAM-1 which interact with PfEMP1 (Roberts, *et al.*, 1992). Agglutination data from the field can be taken as an indicator of the extremely diversity of PfEMP1 and hence *var* genes.

Analysis of *var* DBL1 domain from a panel of different parasite isolates suggests that this diversity is generated by frequent chromosomal recombination during cross-fertilization in mosquitoes (Ward, *et al.*, 1999; Taylor, *et al.*, 2000). Such a suggestion is consistent with the fact that *var* genes are found in the sub-telomeric region of most chromosomes (Rubio, *et al.*, 1996) where chromosome recombination is most frequent. It is clear that *var* genes expression undergoes a high rate of switching (*in-vitro*) (Roberts, *et al.*, 1992; Brannan, *et al.*, 1994; Gardner, *et al.*, 1996) but how this happens remains an open question. By drawing

parallels from antigenic variation in other organisms such as trypanosomes, a number of mechanisms by which antigenic variation in malaria parasites could proceed have been proposed (Borst, *et al.*, 1995, Barry, 1997 #233; Cross, *et al.*, 1998). While there is no evidence for duplicative transposition of inactive *var* genes into expression sites, there is evidence that active genes may be irreversibly lost through deletion (Deitsch, *et al.*, 1999). Experiments using reporter genes fused to a *var* promoter suggest that *var* expression may be under epigenetic control (Deitsch, *et al.*, 1999; Newbold, 1999). Although each parasite only express one *var* gene product on the surface, it appears that initially all *var* genes are transcribed and then selectively degraded to leave only one (Chen, *et al.*, 1998b). As indicated earlier, the spleen (Gilks, *et al.*, 1990) and antibodies have a role in promoting *var* switching (Barnwell, *et al.*, 1983a; David, *et al.*, 1983) but practically nothing is known about the signalling mechanism involved.

Why antigenic variation ?

Because the relative importance of all the antigens on the surface of schizont-infected red cells is yet to be established, for the purpose of this discussion all the surface antigens including PfEMP1, rifins, and sequestrin will collectively be referred to as parasite-induced erythrocyte surface antigens (PIESA). Before discussing the field data on human responses to PIESA I will consider briefly the relationship between PIESA, antigenic variation and host immunity. The amount of genetic resource (2%- 6% of the parasite genome in case of PfEMP1) (Su, *et al.*, 1995) dedicated to PIESA suggests they may have a major survival value. As parasites inside red cells are potentially concealed from the immune system, it puzzling why they express PIESA that give away their location. The classical view is that since changes on the host cell membrane as the parasite matures would eventually make the infected cell susceptible to non-specific splenic clearance (Pongponratn, *et al.*, 1989), PIEsAs' basic function is to sequester the parasites away from the spleen. This view is

supported by observations that parasites passaged in splenectomised animals show reduced expression of PIESA and sequestration (Barnwell, *et al.*, 1983a; Barnwell, *et al.*, 1983b; David, *et al.*, 1983; Gilks, *et al.*, 1990) and also the fact that splenectomised monkeys, unlike intact monkeys, are unable to control the parasitaemia of PIESA-expressing parasites (Contamin, *et al.*, 2000). Because the host would eventually mount an immune response against PIESA, antigenic variation is seen as way of trying to evade these immune responses once they are mounted (Brown and Brown, 1965).

However, two alternative views have been offered for the expression of PIESA. Newbold *et al* (1999) have suggested that the expression of PIESA by non-cytoadherent malaria species indicates that PIESA predates cytoadherence and might initially have evolved for other reasons. The recent findings that *P. falciparum* attaches to and inhibits maturation of dendritic cells through PfEMP1 points to the modulation of the host immune system as a possible reason for the evolution of PIESA (Urban, *et al.*, 1999). A third view is that PIESA may be a parasite population self-regulatory mechanism. By making the otherwise concealed parasites visible to the immune system it enables the host to respond and control parasitaemia. Hence, antigenic variation is a way of maintaining a balance between an overwhelming asexual parasitaemia that would the kill host before transmission has occurred, and the complete elimination of parasites by the host immune system (Hayward, *et al.*, 1999; Piper, *et al.*, 1999a; Saul, 1999). The fact that some knobless parasite lines are unable to maintain a chronic infection lends some credit to this view (Gilks, *et al.*, 1990).

Immune response to parasite induced erythrocyte surface antigens (PIESA)

Studies in animal models

PIESA's location on erythrocytes surface, their characteristics, and potential involvement in the pathogenesis of malaria suggest that they are bound to provoke immune responses in the host. Early information on immune responses to PIESEA came from studying responses to the antigens involved in schizont-infected cell agglutination (SICA) that were subsequently shown to be the animal malaria equivalent of *P. falciparum* PIESEA, and from studies of the strain-specific protection of experimentally infected animals against re-infection by parasite strains homologous to the primary infection.

The development of SICA assays and the demonstration that SICA is variant-specific (Eaton, 1938) made the assays a useful tool for studying antibody responses to PIESEA. Brown *et al.*, (1965) were the first to observe that during chronic infections of *P. knowlesi* in rhesus monkeys, each parasitaemia relapse was accompanied by the appearance of SICA antibodies that were specific to the relapse parasites within six days. Subsequently they showed that the titres of SICA antibodies to a given parasite strain/variant reached a peak three weeks after infection then dropped slightly in the next three weeks before stabilising for at least four months (Brown, *et al.*, 1968). Butcher and Cohen (1972) also reported similar kinetics of SICA antibodies responses against *P. Knowlesi* in rhesus monkeys.

There are several pieces of evidence pointing to the involvement of SICA antibodies in variant-specific protection against malaria in animal models. First, several studies have clearly shown that antibody responses are an important factor in promoting antigenic variation (of SICA antigens) in different animal malaria models (Barnwell, *et al.*, 1983a; David, *et al.*, 1983, Fandeur, 1995 #63). These studies provide indirect evidence that the

interaction between antibodies and SICA antigens is sufficiently adverse to cause the parasite to try and evade it by altering its SICA phenotype. Second, the SICA antigens equivalent in *P. falciparum* have been shown to be involved in the sequestration of mature forms of the parasites in deep vasculature of host organs as a way of escaping the immune system. Sequestration is thought to contribute to the pathogenesis of *P. falciparum* malaria. Thus, one way that antibodies against this antigens could protect against *P. falciparum* infections is to prevent sequestration. David *et al* (1983) showed that resolution of *P. falciparum* infections in squirrel monkeys following treatment with immune sera was preceded by an increase in the proportion of mature parasites in the peripheral circulation of the animals, suggesting that the immune sera reversed sequestration. Finally, the involvement of SICA antibodies in the opsonization of infected cells *in-vivo* has been reported (Brown and Hills, 1971).

However, it should be noted that each relapse during the experimental chronic infections cited above, resulted in a lower peak parasitaemia than in the previous relapses (Brown and Brown, 1965). This suggests that with repeated exposure to malaria parasites, the hosts eventually developed some degree of variant-transcending immunity that might or might not have been directed against SICA antigens.

Studies in humans

Agglutination and surface immunofluorescence assays have been adapted from animal studies to facilitate studies on human immune response to PIESA (Marsh, *et al.*, 1986). Other assays that have also been used include serum-mediated disruption of rosettes (Wahlgren, *et al.*, 1990), cytoadherence inhibition (Udeinya, *et al.*, 1983) and flow cytometry (Piper, *et al.*, 1999b). Although it is not clear how these assays relate to anti-PIESA immune mechanisms *in-vivo*, they have nevertheless given us some insight into anti-PIESA immunity.

The ability of humans to mount a rapid anti-PIESA response following an infection has been demonstrated in several studies; first by Marsh and Howard (1986) who also showed that anti-PIESA agglutinating antibodies are largely-isolate specific and subsequently by others (Forsyth, *et al.*, 1989; Iqbal, *et al.*, 1993; Reeder, *et al.*, 1994; Bull, *et al.*, 1998). These antibodies are mainly IgG of the cytophilic subclasses (Marsh and Howard, 1986; Piper, *et al.*, 1999b), but IgM's involvement cannot be ruled out. Due to its short half-life, IgM would only be detected in studies done immediately following an acute episode and would only be only against the infecting parasites.

Observations from antibody elution experiments (Marsh and Howard, 1986) had suggested that different isolates might express cross-reactive PIESA. However, the isolate-specificity of anti-PIESA antibodies involved in agglutination was demonstrated in an elegant experiment by Newbold *et al.*, (1992). Using a differential staining technique they demonstrated the lack of co-agglutination by different field and laboratory isolates to form. The induction of antibodies during an acute episode to parasites that are apparently not involved in the episode has also been cited elsewhere as evidence for cross reactivity between PIESA variants (Giha, *et al.*, 2000). However, a point to note is that although one PIESA variant might predominate in wild isolates, often, several other variants may be present, albeit in minor proportions. As such, antibodies eluted off one isolate may agglutinate a proportion of other apparently heterologous isolates containing overlapping variants. Second, antigen variation in natural infections means that even a single infection will eventually result in the stimulation of multiple specificities. Giha *et al.*, (1999) reported a high correlation in the induction of anti-PIESA responses to two parasite isolates during a malaria transmission season and concluded that the isolates were expressing an overlapping repertoire of PIESA. The isolates, which came from two siblings who were living in the same house and were simultaneously ill with malaria, were shown to be isogenic with respect to three genetic markers (MSA1,

MSA2 and GLURP). However, they did not form mixed agglutinates indicating they were expressing distinct PIESA. A possible explanation for the correlation is that the isolates were variants from a single parental parasite that were being co-transmitted. Transmission in Daraweesh in the Sudan where the study was done is low and the transmission season brief and may have been insufficient to cause complete disruption of the initial clustering of the two variants. The fact that agglutination of the two isolates by adult sera from a remote location on the other side of Africa (Ghana), where such co-transmission was not expected, showed poor correlation supports this explanation.

A protective role of anti-PIESA antibodies has been suggested by studies in Gambian and Kenyan children and among Sudanese individuals. In the Gambian study (Marsh, *et al.*, 1989), the relationship between titres of antibodies to various malaria antigens and risk of suffering a clinical episode of malaria was determined in a group of children monitored longitudinally during a transmission season. After correction for potential confounders such as age, and bed-net usage, only levels of agglutinating antibodies to a randomly selected wild parasite isolate were found to be associated with protection against an acute malaria episode. In Kenya, the ability of a sera (index) obtained from children who subsequently suffered a malaria episode (cases) to agglutinate parasite isolates obtained during the episode was compared with that of sera from matched control children. The proportion of case index sera that agglutinated the infecting parasites was significantly lower than that of control sera. However, both sets of index sera agglutinated a heterologous parasite isolate to the same extent indicating that children are less likely be infected by parasite against whose PIESA they already had antibodies. Sera obtained from the cases during the episode agglutinated the infecting parasites to a higher extend than either the index case or control sera reflecting the induction of anti-PIESA antibody responses in the cases (Bull, *et al.*, 1998). In the Sudan, the risk of having malaria episode was associated with the inability to detect antibodies to the

surface of a parasite isolate from Ghana by flow cytometry at the beginning of the transmission season (Giha, *et al.*, 2000).

One of the strongest, albeit indirect, piece of evidence that antibodies directed against PIESA with a particular binding phenotype can protect against malaria is seen in pregnancy-associated malaria. Parasites that cause malaria during pregnancy sequester in the placenta mainly (Bray and Sinden, 1979) and have the distinction of binding to chondroitin sulphate A (CSA) only but not CD36 (Rogerson, 1995; Chaiyaroj, *et al.*, 1996; Fried and Duffy, 1996). There is a clear correlation between the possession of antibodies that can disrupt the binding of placental parasites to CSA, or CSA-expressing syncytiotrophoblast cells and protection against malaria during pregnancy. The titres of anti CSA-binding parasites antibodies increase with increasing parity and are accompanied by decreasing incidence of pregnancy-associated malaria (Fried, *et al.*, 1998; Maubert, *et al.*, 1999; Ricke, *et al.*, 2000).

While non-immune individuals are unable to agglutinate any parasite isolates, individuals living in malaria endemic areas exhibit increasing capacity to agglutinate a randomly selected parasite isolate following repeated exposure to malaria (Bull, *et al.*, 1998). Hence immune adults can agglutinate a large number of isolates (Marsh and Howard, 1986; Forsyth, *et al.*, 1989; Iqbal, *et al.*, 1993; Reeder, *et al.*, 1994) including those from remote locations and time (Aguiar, *et al.*, 1992). It is not clear exactly how such a capacity is acquired but two possibilities have been raised. This capacity could simply reflect the accumulation of a wide set of variant specific anti PIESA antibodies over time (Gupta and Day, 1994). Alternatively, the ability to agglutinate isolates that an individual is unlikely to have encountered due to the remoteness of their site of origin and time of isolation (Aguiar, *et al.*, 1992) has been taken as an indication that beyond certain threshold of repeated exposure, a variant-transcending immunity is acquired. On the other hand, it might suggest that the

parasites PIESA repertoire is limited. However, even immune adults fail to agglutinate all the isolate when tested against a sufficiently large panel (Forsyth, *et al.*, 1989; Iqbal, *et al.*, 1993)

Marked seasonal fluctuation in agglutinating antibody has been reported in individuals living in an area with seasonal unstable transmission (Giha, *et al.*, 1998). Individuals who suffered an acute malaria episode during the transmission season predominantly acquired new specificities to both the infecting parasite isolate and also to other isolates. On the other hand, both loss and gain of specificities were observed among individuals who did not did not suffer any acute episode during the season. These observations suggest that both clinical and sub-clinical infections may contribute in the accumulation of variant specific anti-PIESA antibodies. The loss of specificities within a period of four months observed in this study, suggests that some anti-PIESA antibody responses are short lived. An interesting question is whether such short-lived responses are due to host factors or to the infecting parasites' PIESA phenotype.

The relative rarity of severe malaria cases led to the notion this syndrome was caused by a restricted set of rare parasite variants. On the contrary, Bull *et al* (1999, 2000) found that in fact parasites that caused severe disease were more frequently agglutinated by a panel of sera than parasites causing mild disease were i.e. they were more common with respect to PIESA. In addition they also found a negative correlation between the frequency with which a parasites isolate was agglutinated by a panel of sera from children, and the age of the patient from whom the isolate was obtained. Similar observations were made in a study in Daraweesh, although, the authors do not discuss it in their publication. Two isolates from individuals aged 20 and 32 years old were not agglutinated by any pre-transmission season sera from 64 individuals compared to over 30% who agglutinated isolates from 10 and 12

year old individuals. After the transmission season recognition of the first two isolates increased to only 10 and 17 % respectively while recognition of the latter two rose to nearly 100% (Giha, *et al.*, 1998). Taken together, these observations have led to the hypothesis that there may be a trade off between more functionally efficient (hence virulent) but more immunogenic PIESA variant and less immunogenic but also less virulent (more novel) variants. In such a scenario, Variants infecting non-immune individual such as children try to maximise virulence in order to out-compete other variants while in immune adults, the expression of novel PIESA variants to escape immune detection may be more critical to parasites' survival (Bull, *et al.*, 2000).

Doubts have been raised over the usefulness of PIESA as candidates for a malaria vaccine because of the extreme diversity. However, the finding that severe malaria is caused by parasites that express common PIESA variants offers some hope that a vaccine against PIESA might only need to include a limited number of common variants. Among pregnant women, disruption of CSA binding by antibodies was found to be isolate- independent raising hopes that designing a vaccine to stimulate antibodies against CSA binding sites of the parasite may be feasible (Duffy, *et al.*, 2001). Finally, in natural infections, responses to PIESA might be directed mainly toward variable but non-functional regions of PIESA while it might be possible to construct variant-transcending vaccines directed against the more conserved functional domains.

1.6 JUSTIFICATION AND OBJECTIVES

Understanding immunity to malaria is a key pre-requisite for the development of the much-needed malaria vaccines. However, despite years of research, immunity to malaria is still poorly understood. This is partly because of the inability to distinguish between protective and non-protective responses provoked by malaria parasites and partly because longitudinal studies required to provide the data to help untangle these questions are difficult and costly to set up. There is evidence to suggest that responses directed against the variable antigens on the surface of red cells infected with mature stages of malaria parasites (PIESA) may be important in the protection against malaria. However, the natural history of these responses is poorly documented. There is little data describing the kinetics of antibody responses to PIEASA following an acute episode of malaria. In addition, it is thought that acquisition of immunity against malaria may involve the accumulation of variant-specific antibodies against the circulating repertoire of PIEASA variants. However, the dynamics of this process are also poorly documented and understood. Thus, the objectives of the studies described in this thesis were

General objectives.

To Describe the natural history of antibody responses to parasite-induced antigen on the surface of malaria-infected red cells.

Specific objectives

1. To describe the kinetics of antibody responses to PIESA in Kenyan children following an acute episode of malaria with respect to the rate, magnitude, persistence and isotype profile of the responses.
2. To describe the changes in individuals' anti-PIESA specificities repertoire over a period of one year.
3. To determine if having anti-PIESA antibodies to particular isolates at the beginning of a follow-up period is associated with protection against clinical episodes during the follow-up period
4. To examine the influence of chronic infections on an individual's anti-PIESA antibodies repertoire and on the protective role of the antibodies.
5. To use the same longitudinal studies to identify other parasite antigens that might be targets for protective antibody response.

CHAPTER 2

MATERIALS AND METHOD

2.1 STUDY SITE

These studies were carried out at the Wellcome Trust /Kenya Medical Research Laboratories at Kilifi District Hospital, 40 kilometres North of Mombasa on the Kenya coast (Fig. 2.1). The hospital serves nearly 100,000 people living in two areas separated by an ocean creek. The majority of the people belong to the Miji Kenda ethnic group that consists of nine closely related subgroups. An area along the coast line to the north of the creek about 40 kilometres long and 10 kilometres deep was defined in 1991 for demographic surveillance and has been the base for several epidemiological, public health, bed-nets and drug intervention research projects (Snow, *et al.*, 1994).

Malaria transmission is perennial with peaks following the main rainy season in April and September. The main mosquito vectors are the *Anopheles gambiae* complex and *A. funestus* (Mbogo, *et al.*, 1995). Data from a paediatric ward death survey between 1991 and 1995 put the yearly malaria-attributable mortality at 1.2 per 1000 in children below 4 years. However, it is estimated that twice as many children die at home and the corrected rate is 3.8 children per 1000 per year (Snow, *et al.*, 1998a). Although transmission is higher south of the creek (EIR= 60 – 200) than north of the creek (EIR= 10 – 30), the rate of children admission to hospital with severe malaria differs in a somewhat paradoxical manner so that it is higher in the north than in the south (25.9 Vs 16.7 per 1000 children under the age of 10 years) (Snow, *et al.*, 1997).

2.2 ETHICAL CONSIDERATIONS

The proposal for these studies was reviewed and passed as ethically acceptable by the Kenya National Ethic review board. In addition, for each section of the study a fully informed consent (appendix II, III) was obtained from adult on their own or their children's behalf.

Fig. 2.1

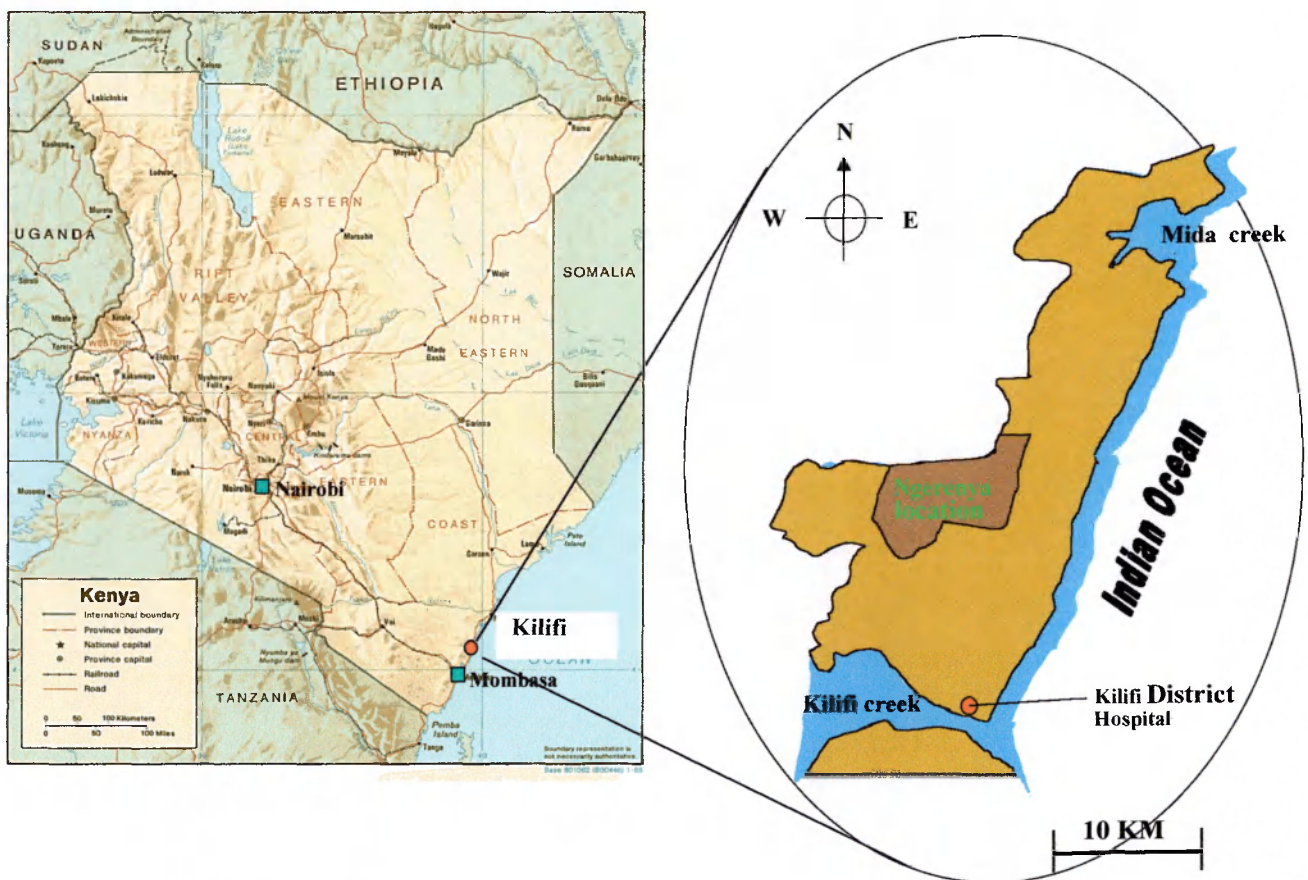

A map of Kenya showing the location of Kilifi. The insert is a close-up map of Kilifi district indicating the location of the district hospital and Ngerenya location where the longitudinal studies were carried out.

2.3 LABORATORY METHODS

Although each section of these studies had a specific design, a number of laboratory techniques were common to most of the sections and will therefore be described in this section for later reference. The validation of these methods will also be described. The suppliers of all the reagents used in these studies are listed in appendix I

Parasite culture

Culture media

RPMI 1640 supplemented with 37.5 mM HEPES, 20 mM glucose, 100 uM hypoxanthine, 2 mM glutamine, 25 ug/ml gentamicin sulphate, and adjusted to a pH of 7.2 with NaOH was used for cell washing purposes and is referred to here simply as “RPMI”. For parasite culture, this RPMI was further supplemented with 10% (v/v) pooled AB serum from malaria non-exposed Europeans, and is referred to as complete culture media. Reagents were either supplied sterile or sterilised by filtration through a 0.22um nitrocellulose filter.

Field isolates

Field isolates were obtained from children at the outpatient clinic of KDH (mild) or from children admitted to KDH with uncomplicated or severe malaria (WHO, 2000). Blood was drawn by venepuncture with a gauge 23 needle either from the dorsum of the hand or the ante-cubital fossae into a 15ml centrifuge tube containing 50ul of heparin (final concentration: 10 – 15ul/ml of blood) and centrifuged at 2000 rpm for 5 minutes to separate plasma. The pellet was

re-suspended in an equal volume of RPMI and carefully layered on top of 3ml of Lymphoprep in a 15ml centrifuge tube. The tube was spun at 4000 rpm for 15 minutes and the supernatant, which contained mononuclear cells, removed. To remove granulocytes, the pellet was suspending in 70% Plasmagel in RPMI, incubated at 37⁰C and allowed to sediment by gravity for 15 minutes. Granulocytes remained in the supernatant and were removed by aspiration. After washing the red cell pellet twice in RPMI, a portion of the cells containing parasites at ring stage was immediately cryopreserved in liquid nitrogen while another portion was put into culture.

Laboratory isolates

All the laboratory isolates were cultured from liquid nitrogen cryopreservation. C4, C10, and A4 are part of the IT4/25/4 clone tree that was generated by Roberts *et al* (1992) (Fig. 2.2). ITGIC15 was also derived from the IT4/25/4 but on a different occasion and was selected for ICAM-1 binding. These clones were kind gifts from Bob Pinches at the Weatherall Institute of Molecular Medicine, Oxford. The parasites were occasionally floated on Plasmagel during culturing to select for knobby variants (Pasvol, *et al.*, 1978).

Figure 2.2

Tree showing the derivation of some of the laboratory clones used in this thesis (bold font) (Roberts et al, 1992)

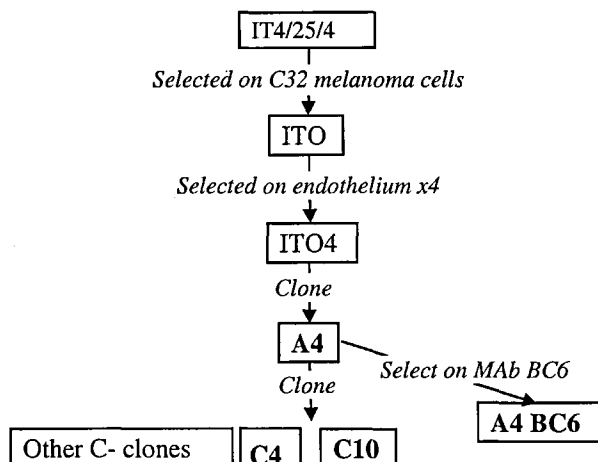

Cryopreservation and recovery of field and laboratory isolates

Parasites were cryopreserved in glycerolyte. To prepare glycerolyte, 26.6g of Sodium lactate, 300mg of KCl, and 15.8g of NaH₂PO₄ were added to 590g of glycerol and the mixture made up to one litre with deionised water. The pH was adjusted to 6.8 using NaOH, the solution filtered through a 0.45µm filter and stored at 4°C.

To cryopreserve the parasites, an infected cell pellet was obtained from culture by centrifugation, and washed twice in RPMI. 1/3 X pellet volume of glycerolyte was added slowly over five minutes with continuous agitation and then the tube was left to stand for five minutes. A further 3 X pellet volume of glycerolyte was added in the same manner, as was the first. 1 ml aliquots of the suspension were put into 1.2ml cryovials, labeled, and stored in a -80°C freezer overnight before being transferred to a liquid nitrogen tank for long-term preservation.

Thawing of the frozen stabilates

The parasites were thawed rapidly by enclosing the cryo-tube in a fist. The stabilates was then transferred to a 15 or 50 ml centrifuge tube depending on volume. Recovery was by a three step restoration of isotonicity, beginning with 12% saline added slowly over 5 minutes to a 1:5 saline to sample volume ratio. After incubation for five minutes at room temperature, 5 volume of 1.8% saline was added gradually. The sample was then centrifuged at 1800 rpm. A final wash in 5 volumes of 0.9% saline/ 0.2% glucose solution was done before suspending the pellet in RPMI.

Cultivation of parasites

Field isolates were either cultured freshly immediately they were obtained from the patient or recovered from cryopreservation, while all the laboratory clones were recovered from cryopreservation and maintained by diluting with fresh O positive red blood cells from a volunteer. Culture was according to standard methods (Trager and Jensen, 1976) at 37 °C in complete culture media. The amount of complete culture media required for culturing a given volume of parasite was given by the formula:

$$\text{Packed cell volumes (ml)} \times \text{Parasitaemia (\%)} \times 5 = \text{volume of culture media required (ml)}$$

The cultures were gassed with a 3% CO₂, 5% O₂, 92% N₂ mixture. When necessary, Aphidocolin (1.5ug/ml) was added to the culture to synchronise growth by arresting development at the mature schizont stage (Inselburg and Banyal, 1984). This treatment does not affect the parasite agglutination phenotype (Bull, *et al.*, 1998).

Determination of Parasitaemia

The percentage of cells infected was assessed by microscopy. A 200ul aliquot of culture was pipetted into a 0.5ul Eppendorf tube using a Gilsons pipette and centrifuged to obtain a cell pellet. The pellet was then pipetted on to a clean glass slide and a thin film prepared by the standard technique of spreading the cells with the edge of another slide that is inclined at a 45⁰. The smear was fixed with methanol and staining done for 10 minutes with 10% giemsa in phosphate buffer, pH 7.2. Excess stain was then washed off with tap water and the slides dried in either air or using a blow dryer. 1000 cells were counted through a 100x objective lens under

oil immersion and the number of cells infected by each stage (rings, mature trophozoites and schizonts and gametocytes) expressed as a percent.

In the longitudinal studies, where the parasitaemia was too low to be effectively detected by thin smears, a thick smear was prepared. To do this, a small volume of blood was pipetted on a glass slide and spread in to circular smear with the corner of another slide. The smear was then left to dry for at least an hour before being carefully overlaid with 10% giemsa stain in buffer (pH 7.2). The slides were stained for 10 minutes, washed, dried, and examined through a 100x objective lens under oil immersion. Parasites were expressed relative to 200 white blood cells (WBC) and then converted to parasite per micro litre of blood by the formula below:

$$\text{Patients WBC count (per ul)} * \text{parasite count}/200$$

Agglutination assays

The method of Marsh *et al* (1986) was used with some modifications. This method depends on the ability of antibodies against the malaria parasite-induced erythrocyte surface antigens (PIESA) to agglutinate red cells infected by mature malaria parasites in a variant-specific manner. The agglutinated cells are visualized under low power microscopy against a dark background by staining them with a fluorescent dye such as acridine orange or ethidium bromide and illuminating them with UV light of the appropriate wavelength (Fig. 2.3).

Parasite isolates were assayed when the majority of parasites in a culture were in late trophozoite or schizont stage. A red cell pellet was obtained from the culture by centrifugation at 1800rpm. The cells were washed thrice in RPMI and the parasitaemia adjusted to between 1 – 5% by

adding an appropriate volume of uninfected cells. A 5% haematocrit suspension of the parasitised red blood cells in RPMI was prepared and ethidium bromide added to a final concentration of 10ug/ml. 10ul of the suspension was pipetted into 0.5ul Eppendorf tubes or into a U-bottomed 96-well. To avoid the effect of drying, the wells in outmost rows and columns on the plate were not used instead 25 ul of plain RPMI was pipetted into them. 2.5 ul of test serum was then added into the tube or microtitre plate well and the mixture agitated continuously on a vertical rotator at 25 rpm for 1 hour at room temperature.

Initially, the reactions were examined as wet smears. To prepare these, the reaction mixture was pipetted onto a clean microscope slide and covered with a petroleum jelly-rimmed glass slip to prevent drying. The slides were then examined by microscopy under UV light at x10 objective. Agglutinates were sized relative to a 0.1 mm graticule and a score assigned as follows an agglutinate of 3-5 cells was assigned a score of one; while agglutinates that were $\approx 1/8$ graticule (5-10 cells) were assigned a score of 2; $\approx 1/4$ graticule (11-30 cells) = 4; $\approx 1/2$ graticule (31-70 cells)= 8 and ≈ 1 graticule (>71 cells)=16. The total score for each slide was calculated by multiplying the number of agglutinates of each size by the numeric score assigned to that size and then summing up the scores for the five sizes. Checkerboards based on the total score were constructed to facilitate visual comparison of scores.

Figure 2.3

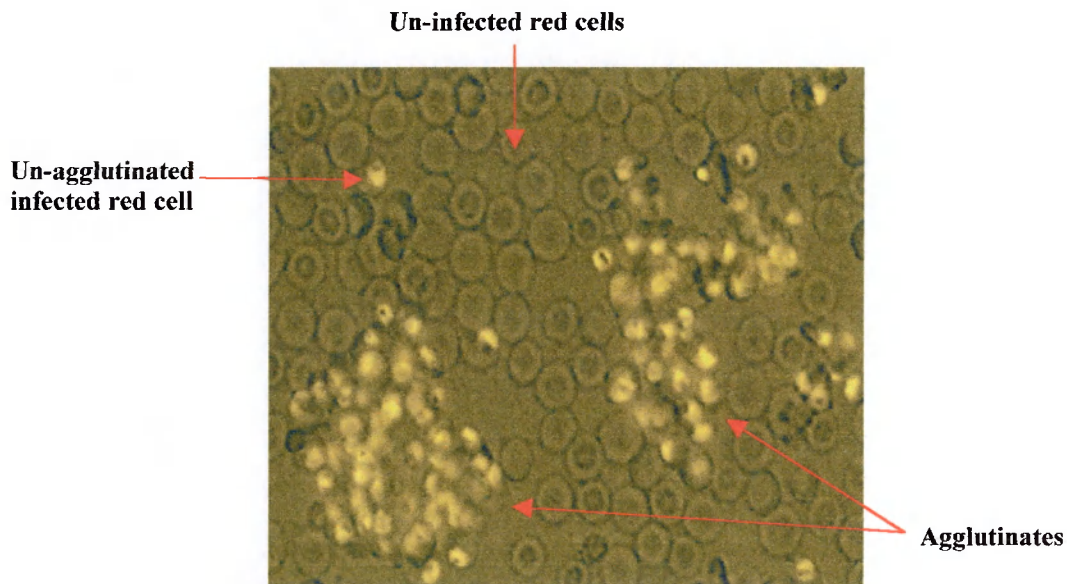

An example of agglutinates stained with acridine orange and illuminated with UV light to contrast the infect cells with un-infected cells.

Modification of agglutination assays to allow longer storage of slides

Because wet smears can only be maintained for a few hours before the parasites begin showing sign of deterioration, it would have been impossible to carry out experiments that involved a large number of reactions or required simultaneous reading of slides prepared at different times. Therefore, a modification of the assay was made to facilitate longer storage of the slides. The reactions were carried out as before except that the fluorescent dye was not added during the preparation of the reaction mixture. At the end of the rotation, instead of making wet smears, the mixture was spread out onto a microscope slide into a circular thin smear of about 18mm diameter and left to dry in air before fixing with methanol for about 30 seconds, these slides could then be stored for later reading. This method compares well with the use of wet smears,

could then be stored for later reading. This method compares well with the use of wet smears, while allowing slides to be stored for later simultaneous blinded assessment. To read the dry smears, 12.5ul of acridine orange (10 ug/ml) were placed on an 18 x 18 mm cover slip and the agglutination slide inverted on it to stain the slide. The entire smear was examined microscopically in a manner similar to the wet smears.

Flow cytometry

An increasingly larger number of publications are reporting the use of flow cytometry as a method of exploring the expression of and immunity to PIESA (Piper, *et al.*, 1999b; Urban, *et al.*, 1999; Giha, *et al.*, 2000). There are a number of reasons why flow cytometry has been adapted as a method of studying responses to PIESA. First, it is a more rapid and less labour intensive method and hence a larger number of samples can be assayed at a time. Second, it is less subjective than agglutination assays hence results can be better standardized. Third, it is difficult to assess the isotype of antibodies that bind to the surface of infected cells except by flow cytometry. Fourth, flow cytometry yields data that are more easily analysed with standard mathematical techniques than data from agglutination assays. However, a word of caution here is that the two assays may not necessarily measure exactly the same parameters although one would expect them to overlap to some extent. It is possible that not all antibodies bound to the cell surface, which are otherwise detected on a flow cytometer, mediate agglutination (Table 2.4)

The assay

A pellet of red cells infected by mature parasite stages was obtained from culture by centrifugation at 1800rpm. The pellet was washed thrice in RPMI, and then re-suspended at 1% haematocrit in 0.1% Bovine serum albumin/Phosphate buffer saline (0.1%BSA/PBS). 10ul of the infected cell suspension was placed in a well of a round-bottomed 96-well plate and 2.5ul of test serum added to give a final test serum dilution of 1:5. The reaction mixture was incubated for 30 minutes at room temperature following which the cells were washed thrice with 0.1% BSA/PBS centrifuging at 1500 rpm between each wash to remove the wash medium. After washing, the cells were re-suspended in 50 ul of 0.1% BSA/PBS containing 10ug/ml ethidium bromide and a 1:50 dilution of FITC-coupled goat antibodies directed against either human IgM, IgG or the four IgG isotypes (IgG1, 2,3 and 4) (Binding Site, UK) depending on assay. After incubation for another 30 minutes, the cells were washed thrice and at least 1000 infected erythrocytes counted on an EPIC/XL flow cytometer (Coulter-electronics, UK).

The formula by which the percentage of infected cells staining positive for bound antibodies (FITC fluorescence) and their mean fluorescent intensity is given along with figure 2.4.

Figure 2.4

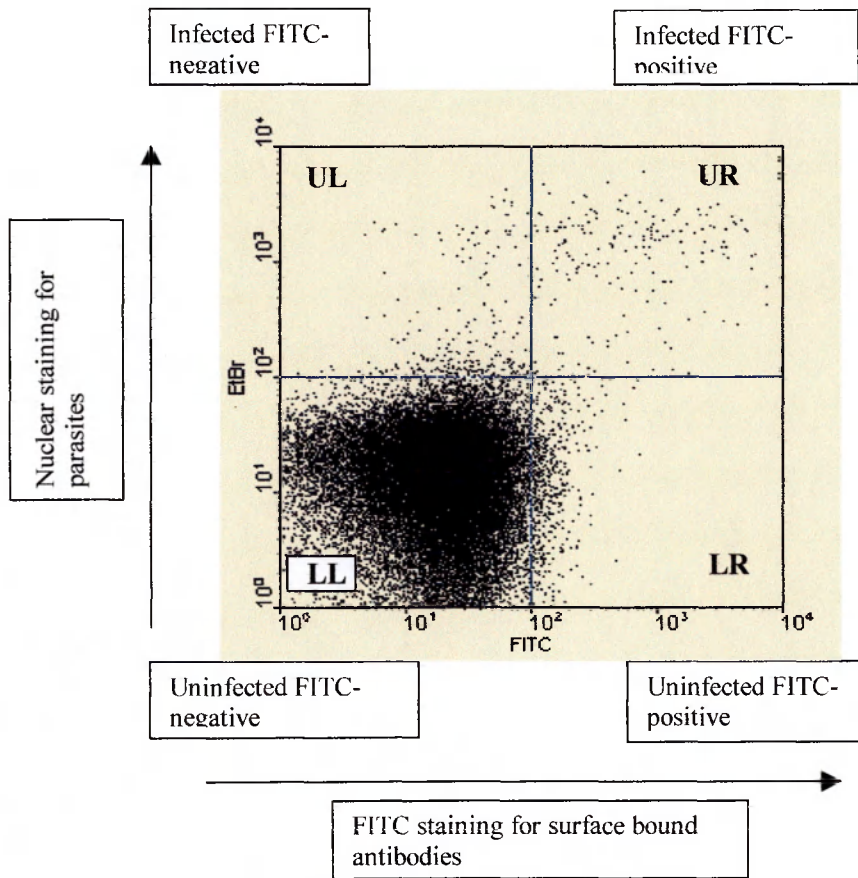

An example of a flow cytometer output graph showing the four regions into which cells may be sorted.

The mean fluorescent intensity (MFI) is given as a ratio

$$\frac{(MFI_{UR} \times COUNT_{UR}) / (MFI_{UL} \times COUNT_{UL})}{(MFI_{LR} \times COUNT_{LR}) / (MFI_{LL} \times COUNT_{LL})}$$

and the percent infected cell positive for FITC

$$\left[\frac{COUNT_{UR} / (COUNT_{UR} + COUNT_{UL})}{COUNT_{LR} / (COUNT_{LR} + COUNT_{LL})} \right] \times 100$$

Where COUNT is the number of cells in the subscripted quadrant.

2.4 VALIDATION OF THE LABORATORY METHODS

Validation of the agglutination scoring method. (Fig. 2.5)

In order to assess the reproducibility of the method used to score agglutination, A4 parasites were assayed against a panel of 20 children plasma. Duplicate dry agglutination smears were prepared from each reaction, blinded and scored. The difference between the pair scores was tested for significance using a paired t-test. Bias was assessed by the method of Altman, 1991. In this method, a scatter plot of the difference between the pair scores and the average of the pair is constructed. Symmetry of the plot around X-axis (zero difference) indicates a lack of systematic bias. The duplicate scores did not differ significantly ($P=0.960$) and the scatter plot revealed a high level of correlation ($r = 0.998$) between the scores. The plot of the difference between the pairs versus the average of the pair was symmetrical around zero indicating that there was no systematic bias for one set of scores.

Figure 2.5

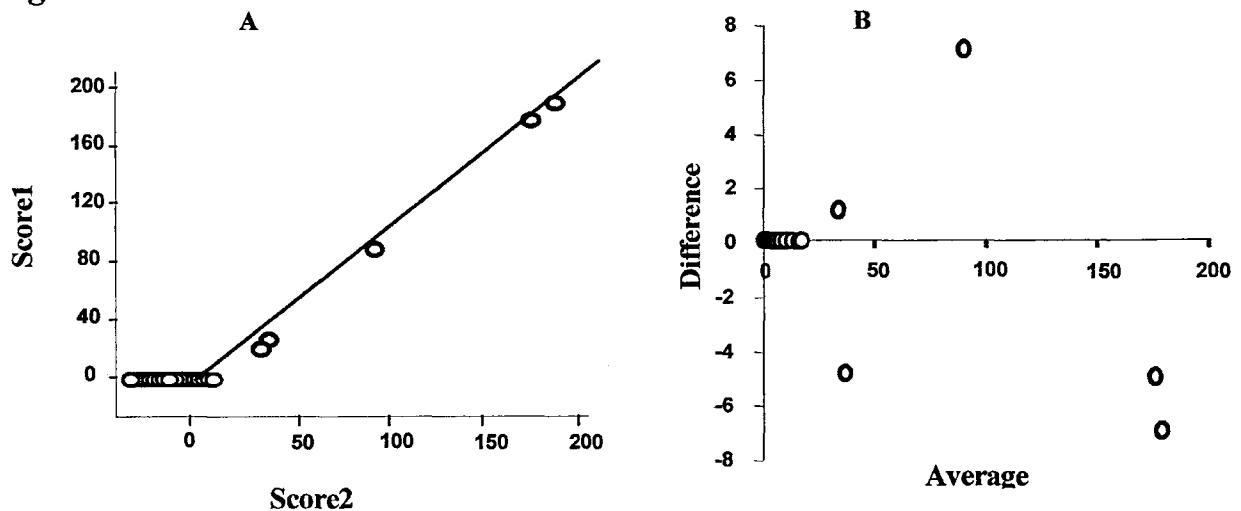

A) Scatter plot of scores from duplicate assays. The diagonal line represents score1=score2. (B) A plot of the difference (score 1-score2) Vs the average of the scores (score1+score2) /2.

Effects of repeated freezing and thawing plasma on agglutination antibodies.

(Fig. 2.6)

Freezing of plasma is a standard storage procedure in many field studies. However, it is widely believed that repeated freezing and thawing of plasma may be detrimental to antibodies although I could not find published data supporting this notion. Since my studies involved the storage of plasma samples at -20° C, it was necessary for me to establish if, and how much, repeated freezing and thawing of the samples could be adversely affect the antibodies present in them.

Serum samples obtained from two immune adults in an earlier study were selected on basis of their ability to agglutinate the A4 parasites. The plasma was aliquoted and frozen at -20° C. Subsequently, the samples were subjected to either 2, 4, 8 or 16 freeze-thawing cycles before assessing their ability to agglutinate A4 parasites. The samples were allowed about half an hour of thawing by which time they achieved room temperature and then immediately put back into the freezer. At least a 2-hour lapse was allowed before the next thaw. Each sample was assayed at 1:5, 1:10, 1:20, 1:40, and 1:80 dilutions. The titre of agglutinating antibodies in the sample was taken as the highest dilution at which agglutinates were still evident. A checkerboard was constructed to allow visual assessment of the scores. Before the first freeze-thaw cycle, the antibodies in the samples titred out at a 1:40 dilution. After the first freeze-thaw cycle, a drop was observed in the titres (1:20) after which they remained constant even after another 15 freeze-thaw cycles.

Figure 2.6

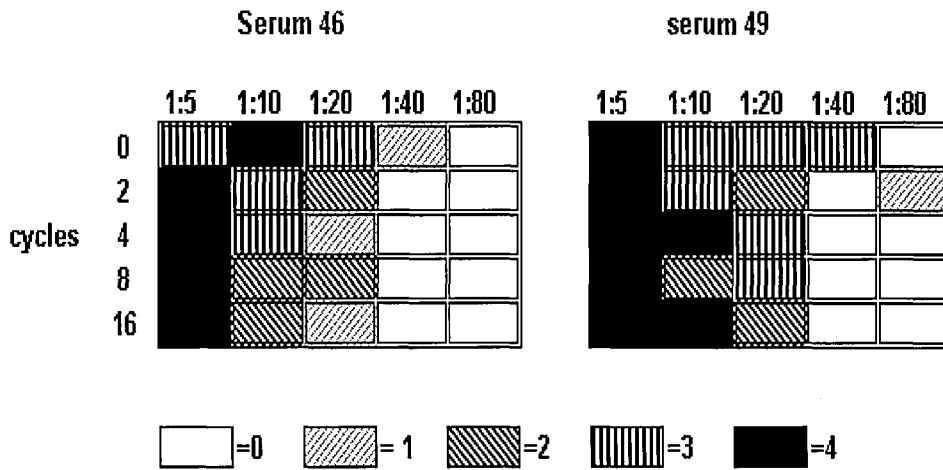

The effect of repeated freezing and thawing of serum on agglutination. 0–4 indicate increasing degrees of agglutination where 0 is negative.

Inter-assay variation. (Fig. 2.7)

Profiles of agglutination of 6 wild and one laboratory isolate (A4) by a panel of 8 children plasma were compared in duplicate experiments that were separated by an hour's interval. Pooled plasma from malaria non-immune Europeans and RPMI were included in order to assess non-specific agglutination. Aphidocolin was used to arrest parasite growth at the schizont stage and prevent possible PIESA changes during the intervening hour. Kappa-statistic was used to determine if the concordance between the experiments was significantly different from the level of concordance that could be observed if the data was generated randomly (Kappa-statistic ranges from 0 when there is no agreement to 1 when the agreement between sets of outcomes from duplicate experiments is perfect).

While the agglutination profiles of 2 isolates (1433 and 1489) did not show any variations in the duplicate experiments, the profiles of the other 5 showed variations involving gain or loss of positivity. Overall, 82% concordance was observed between the experiments (expected concordance if the variation was random = 56%, Kappa=0.602, P<0.001). The variation was not biased towards either of the experiments, so that while isolates A4, 1424, 1542, and 3983 lost positivity with some plasma in the second experiment, isolate 3950 appear to have acquired novel positivity. However, within the isolates, the gain or loss of positivity tended to be biased towards one experiment. Except for plasma 10 which showed a slightly higher tendency to react positively with parasites in the first but not the second experiment, reactions with the rest of the plasma were not biased for either experiment. Isolate 3893 showed non-specific agglutination in non-immune plasma in the first experiment but subsequently lost it in the second. It was in this isolate also that the highest variation was observed with all the positive reactions (5 out of 10 plasma) in the first experiment becoming negative in the second.

Figure 2.7

Agglutination profiles of seven isolates against a panel of 10 plasmas from duplicate experiments (a and b). Eu - Non-immune European plasma. The scores are represented on a semi-quantitative scale of increasing intensity from negative to 4.

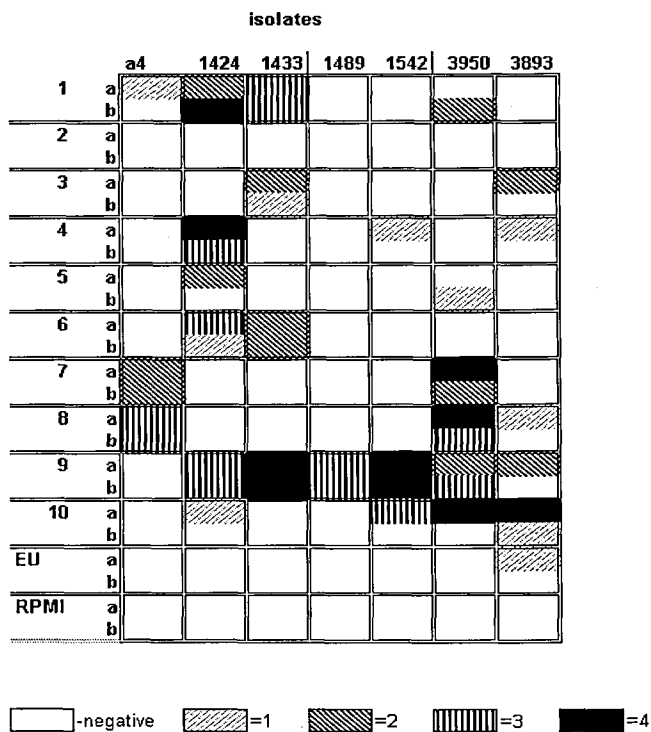

Correlation between antibody titres and flow cytometry parameters. (Fig 2.8)

Two parameters are considered when using flow cytometry: 1. The percentage of infected cells that have antibodies bound to their surface as indicated by positive FITC staining. This reflects both the proportion of infected cell expressing PIESA variants against which there are antibodies present in the test plasma and the titres of those antibodies. 2. the mean fluorescent intensity (MFI) of the positive cells which potentially could reflect three things: a) the amount of antibody bound to the cells and therefore a proxy measure for titre; b) the affinity of the antibodies binding to the cell surface and c) the amount of PIESA being expressed by the cells. I assessed the relationship between both of these parameters and titres of anti-PIESA antibody in plasma samples in order to facilitate the interpretation of our flow cytometry data.

Serial dilution of plasma from a malaria immune adult was tested for antibodies against A4 and a wild isolate 3353. The A4 was grown in culture and floated on Plasmagel to concentrate PIESA-expressing parasites. The culture was then diluted down to a 2% parasitaemia with fresh O positive red cells and grown for one generation before the assay was carried out. Isolate 3353 was recovered from cryopreservation and cultured overnight before being diluted to a 5% parasitaemia with fresh group O red blood cells and left to grow to maturity. Both isolates were first tested for agglutination in the test serum and shown to be positive. The test plasma was diluted in AB pooled plasma from malaria non-immune European adults in the following ratios - 1:5, 1:25, 1:50, 1:100, 1:200, 1:400, 1:800, and 1:1600. The pooled European sera were also used as a negative control.

Figure 2.8

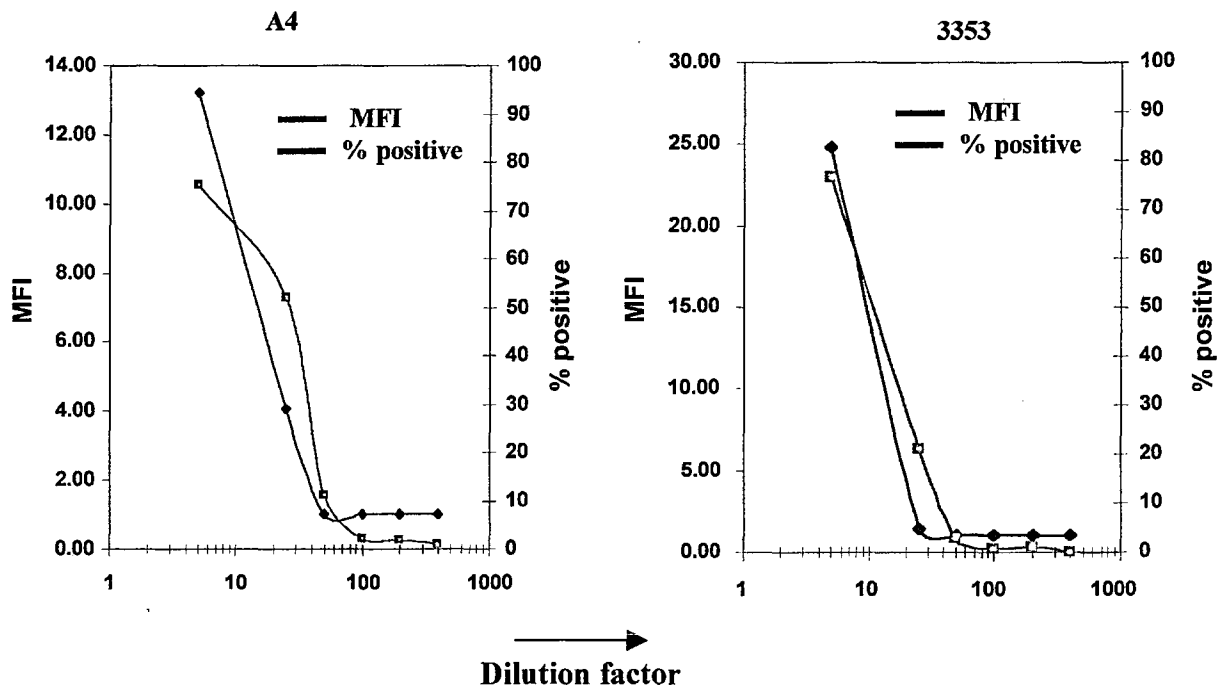

Plots of the ratio of MFI in test VS non-immune AB pooled plasma MFI and percentage of cell positive for FITC staining against plasma dilution

The parasites were assayed when the majority of parasites were in the mature stage. Agglutination assays were first done to confirm that the parasites were still expressing PIESA and that the serum selected had antibodies against the PIESA of the isolates being tested. The test plasma agglutinated both isolates although to a different extent. Large three-dimensional agglutinates were observed with A4 while few and smaller isolates were observed with 3353.

Antibodies against both isolates titrated out at a dilution of 1:100. Below, this dilution, titre was highly correlated with percentage of cells positive for FITC and also the MFI of the cells ($R > 0.8$, $P > 0.001$) except in the case of A4 where the percentage of cells positive and titres were less

well correlated ($r=0.65$). It was observed that at the lowest dilution (1:5) the percentage of A4 cells positive was lower than the correlation model predicted (Fig. 2.8). It was also observed that the parasitaemia detected in this sample was significantly (Z score $P = 0.001$) lower than in the rest of the samples (1.78 Vs 5.73 ± 0.72 -mean \pm SD). Examination of a sample of the A4 1:5 dilution reaction mixture by microscopy revealed that some of the infected cells had agglutinated.

The use of cryopreserved schizonts in agglutination assays and flow cytometry

Because the mature parasites that express PIESA sequester in capillary beds and are absent in the peripheral circulation, parasite samples for studies on PIESA are obtained and cryopreserved as rings and cultured to maturity when required. However, this has limitations as some cryopreserved isolates do not grow in culture upon thawing (Forsyth, *et al.*, 1989; Reeder, *et al.*, 1994) and among those that do, a substantial proportion of parasites may be lost during cryopreservation and thawing. Thus, recovery from cryopreservation could select a parasite subpopulation with altered characteristics (Jadin, *et al.*, 1976). Second, variation in the times that recovered rings from different isolates take to mature makes planning experiments involving simultaneous assaying of many isolates difficult. I therefore used two approaches to examine whether mature *P. falciparum* stages grown from fresh blood and cryopreserved in glycerolyte are suitable for determining PIESA phenotype by agglutination and by flow cytometry.

First, I used mixed agglutination to determine if cryopreservation of schizonts affected the variant-specificity of agglutination assays and second, I assessed the effect of cryopreservation

on the reactivity profiles of 9 isolates against a panel of 22 children sera using agglutination and flow cytometry. Parasite culture, cryopreservation, thawing agglutination assays, and flow cytometry were carried out as per the protocols described earlier on.

Recovery of cryopreserved mature parasites. (Table 2.1)

Recovery is given as the parasitaemia after cryopreservation expressed as a percentage of the parasitaemia before cryopreservation. Parasitaemia was determined by flow cytometry. A pellet of cells was incubated for 10 minutes with ethidium bromide, washed thrice in 1% BSA/PBS buffer and run through the flow cytometer. 100,000 cells were counted. The difference between the mean parasitaemia for the fresh and recovered sample was assessed for significance using a paired t-test. Parasitaemia was higher, although not significantly ($P=0.412$) in the fresh samples ($2.83\% \pm 2.12$) than in the cryopreserved ones ($1.83\% \pm 1.5$) (mean \pm 95% C.I.). The mean recovery rate for the cryopreserved parasites was $84.56\% \pm 24.23$. Despite appearing to be morphologically intact, the recovered parasites failed to grow in culture and turned pyknotic after 24 hours.

Table 2.1

Isolate	fresh	Cryo	% recovered
T996	0.87	0.90	103.45
va12	0.79	0.63	79.75
va13	1.46	1.41	96.58
va14	3.97	1.72	43.32
va9	0.47	0.58	123.40
va6	2.27	3.00	132.16
va8	3.02	1.40	46.36
va7	9.78	5.03	51.43
mean	2.83	1.83	84.56
sd	3.06	1.50	34.96
95% CI	2.12	1.04	24.23
P (ttest)		0.4124	

Recovery of schizonts from cryopreservation. Fresh is percentage of red cells parasitised at time of cryopreservation while cryo is the parasitaemia of the recovered sample. % recovered = cryo / fresh X 100.

The effect of cryopreservation on the degree of mixed agglutination between laboratory isolates. (Table 2.2)

The rates of mixed agglutination among fresh (FS) and cryopreserved schizonts (CS) of three laboratory isolates; A4, C10, and C4 (Fig. 2.2) were compared. The method of Newbold *et al* (1992) was used. Briefly, the isolates were grown to maturity diluted to an equal parasitaemia (3 - 4%) and an aliquot of each cryopreserved. The remaining cells from each culture were divided

into two portions and one portion stained with DAPI (1 ug/ml) and the other with ethidium bromide (10ug /ml) for 5 minutes. The cells were then washed thrice with RPMI and re-suspended at 5% haematocrit. 5ul of cell suspension of one isolate was mixed with 5ul of cell suspension from a second isolate that had been stained with a different dye. The resulting 10ul of suspension were mixed with 2.5ul of immune adult serum and rotated on a wheel for an hour to facilitate agglutination. Wet smears were then prepared and blinded before scoring the reactions. 100 agglutinates were considered and the proportion of agglutinates that contained cells stained by both dyes taken as the degree of mixed agglutination. The assays were then repeated using cryopreserved schizonts and the degree of mixed agglutination compared with that observed in among fresh schizonts.

Table 2.2

Isolate Pairs stain	Fresh schizonts		Cryopreserved schizonts	
	Single colour	mixed	Single colour	mixed
<i>A4 EtBr - A4DAPI</i>	0	100	2	98
<i>C10 EtBr - C10 DAPI</i>	0	100	0	100
<i>C4 EtBr - C4 DAPI</i>	2	98	0	100
<i>A4 EtBr - C4 DAPI</i>	95	5	78	22
<i>A4 DAPI - C4 EtBr</i>	90	10	88	12
<i>C10 EtBr - C4 DAPI</i>	85	15	92	8
<i>C10 DAPI - C4 EtBr</i>	87	13	86	14

The Degree of mixed agglutination among fresh and cryopreserved schizonts of three laboratory isolates.

The three isolates exhibited between 5% and 13% mixed agglutination. However, C10 and A4 exhibited over 40% mixed agglutination and the combination was not used in the assays. No changes were observed in the level of mixed agglutination when cryopreserved schizonts were used in the assays except in one combination A4 (EtBr) - C4 (DAPI) where a slight increase occurred. However, the cryopreserved schizonts from the same isolates that had been stained in a reverse manner A4 (DAPI) - C4 (EtBr) did not exhibit increased mixed agglutination.

Agglutination profiles of fresh and cryopreserved schizonts. (Fig. 2.9)

Reactivity profiles of fresh and cryopreserved schizonts from 9 isolates with a panel of 22 children plasmas were compared. The isolates showed distinct agglutination profiles with some (va13) reacting positively with the majority of the plasmas while others (va5) were positive with just a few. T9/96, an isolate that does not express PfEMP1 did not agglutinate in any of the plasmas. Only va5 and A4 retained the same agglutination profiles in FS and CS while the rest of the isolates showed some degree of variation. Although variations involving decrease in degree of positivity were observed, here I have mainly considered those variations that involved complete loss or the gain of novel positivity. A good level of concordance was observed in agglutination of schizonts from the two sources (concordance = 86.96%, expected concordance = 60.72%, Kappa = 0.667, $P < 0.001$). While a predominant loss of positivity was observed in va13 and va8 following cryopreservation, the other isolates exhibited a less biased variation with both gain and loss of positivity occurring. Non-specific agglutination by non-immune plasma was observed in FS of va7, va8, and va12 but not in the CS. None of the plasma showed a bias towards agglutinating schizonts from either sources.

Figure 2.9

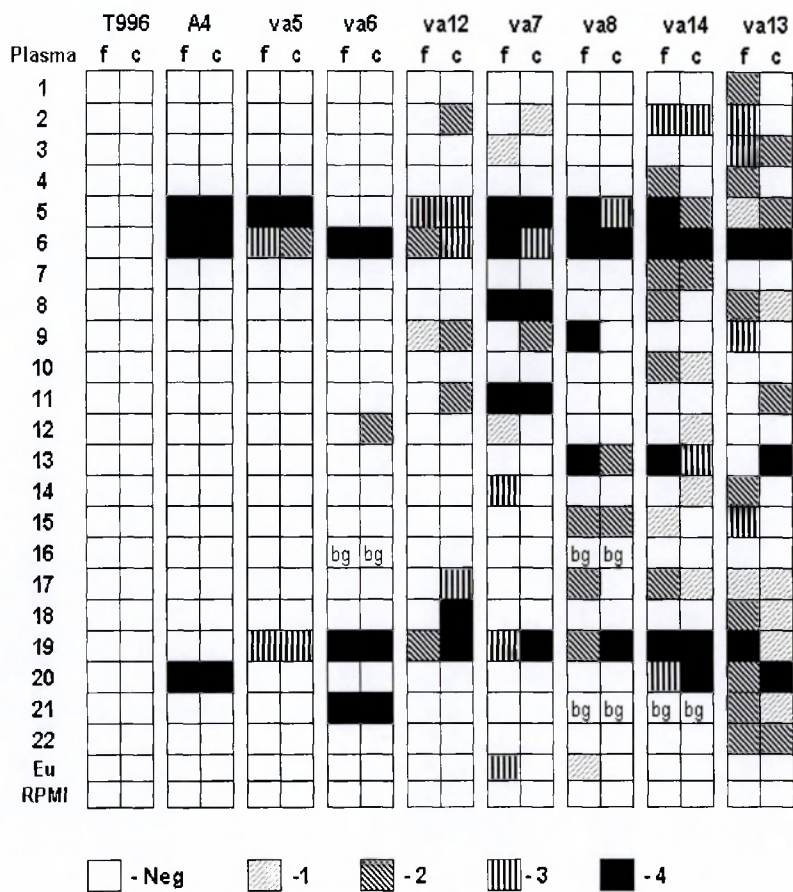

Agglutination of fresh (f) and cryopreserved (c) schizonts of 9 isolates by a panel of 22 plasmas, pooled plasma from non-immune Europeans (Eu) and RPMI were included to assess non-specific agglutination. bg- blood group incompatibility.

Detection of antibodies bound to the surface of fresh and cryopreserved schizonts by flow cytometry. (Table 2.3 & Fig. 2.10)

Antibody binding to the cells surface was assessed in two ways; the proportion of infected cells that were positive, and the mean fluorescent intensity (MFI) which is a proxy measure of the amount of antibody binding to each cell. For each isolate, the difference in percentage of infected FS or CS positive for surface FITC staining or in their MFI was assessed for significance using a paired t-test. All the paired data was then pooled, log transformed and the difference between FS and CS plotted against the average of the pair, $(FS+CS)/2$. Table 2.3 gives a summary of the flow cytometry data. The mean percentages of infected cells positive for antibody binding was greater in FS of isolates; va5, va6, va7 and va12 and in the CS of isolates va8, va13, va14 but the differences were not significant.

Figure. 2.10

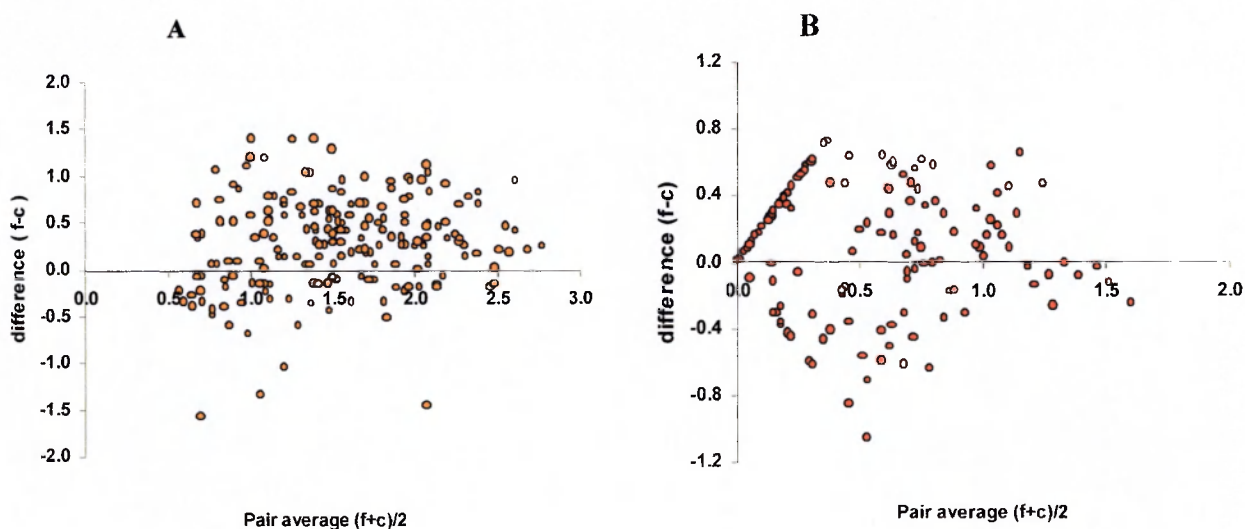

Plots of the difference and the average of log-transformed A) MFI and B) percent of cells positive for fresh and cryopreserved schizont pairs.

A strong correlation was observed between the paired data. On the other hand, mean MFI was consistently higher in FS than in CS in all the isolates, the difference being significant ($P < 0.05$). The plots in figure 2.10 shows that the difference between percentage of FS and CS positive is symmetrical about zero thus there is no systematic bias toward either set of cells while the plot of MFI differences is biased towards FS.

Table 2.3

		% cells positive			MFI		
		Mean (Range)	P	*Corr. Coeff.	mean	P	*Corr. Coeff.
va5	FS	4.12 (0 – 30)			100.9		
	CS	1.51 (0 – 9)	0.103	0.877	26.1	0.006	0.521
va6	FS	2.91 (0 – 14)			111.1		
	CS	2.23 (0 – 18)	0.318	0.895	28.21	0.443	0.443
va7	FS	3.12 (0 – 21)			42.0		
	CS	1.73 (0 – 21)	0.219	0.857	11.3	0.022	0.835
va8	FS	4.23 (0 – 29)			77.5		
	CS	7.13 (0 – 53)	0.228	0.950	24.6	0.002	0.849
va12	FS	8.36 (0 – 21)			102.4		
	CS	2.91 (0 – 26)	0.385	0.926	94.2	0.530	0.782
va13	FS	4.65 (0 – 14)			95.7		
	CS	5.24 (0 – 15)	0.375	0.702	30.9	0.000	0.600
va14	FS	2.29 (0 – 14)			33.2		
	CS	2.70 (0 – 15)	0.260	0.791	27.0	0.556	0.017

*Comparison of mean percentage cells positive and MFI of FS and CS of various isolates reacted with a panel of 22 children plasma samples. The P - paired t test of the difference between the means . * Coefficient of the correlation between reactivity of CS and FS to the plasma panel.*

Correlation between Flow cytometry and agglutination (Table 2.4)

Each isolates' flow cytometry data from both fresh and cryopreserved schizont were pooled and assessed for correlation with pooled agglutination scores (44 data pairs). The level of correlation varied among the isolates but agglutination correlated better with percent cells positive than with MFI and the correlation was significant in all instances. Between themselves, the two flow cytometry parameters were only moderately correlated ($r^2 = 0.588$).

Table 2. 4

Isolate	Agglu. Vs % cells positive		Agglu. Vs MFI	
	Corr. Coeff.	P value	Corr. Coeff.	P value
Va5	0.683	>0.001	0.506	0.001
Va6	0.722	>0.001	0.303	0.045
Va7	0.553	>0.001	0.384	0.100
Va8	0.800	>0.001	0.532	>0.001
Va12	0.410	0.004	-0.050	NS
Va13	0.443	0.003	0.123	NS
Va14	0.565	0.001	0.128	NS

The correlation between percent of cell positive on flow cytometer, MFI and agglutination (agglu). n =44 pairs per isolate. P values for the coefficients are given in brackets. NS – not significant.

2.5 DISCUSSION

A number of experiments were conducted to validate the laboratory methods that were to be used in these studies. This was necessary in order to know the optimum conditions for the assay and the level of inherent assay variation expected. First, I assessed the reproducibility of the scoring method that was used in the agglutination assays. Scoring agglutination assays is inherently subjective and might be expected to be prone to poor reproducibility, especially when a scale that is more complex than a simple binary negative/positive scale is used. However, I observed good agreement between scores of duplicate smears prepared from the same reaction tube and no systematic bias indicating that the method of scoring was highly reproducible.

I examined the widely held belief that repeated freezing and thawing could affect the concentration of antibody in plasma and serum samples. Plasma samples were subjected to between 2 and 16 freeze-thaw cycles and the levels of agglutinating antibodies in the samples assessed. The first freezing-thaw cycle resulted in a two-fold decrease in antibody levels in all the samples, subsequent cycles did not have any effect. One possibility is that some antibodies sedimented out of the plasma along with other plasma protein that were precipitated following the first freezing cycle. These results notwithstanding, the plasma samples used in these studies were aliquoted into small volumes each sufficient for only a few assays in order to minimise number of freeze-thaw cycles that each sample was subjected to. In addition, fresh and frozen samples were not used in the same assay.

Having established that the scoring method I intended to use for these studies was reproducible and that freezing-thawing plasma did not affect the levels of antibodies in my samples

significantly, I went on to explore the level of inter-assay variation that is expected when using fresh schizonts in agglutination assays. The modification of the assay to using dry agglutination smears, which unlike wet preparations can be stored for a long time, allowed the simultaneous reading of slides from assays done at different times. Duplicate experiments that were separated by an hour were done and the reactions scored blind. Agglutination by a panel of plasma of all but two isolates varied between the two experiments. While slight changes in assay parameters and scoring could explain minor variations, the larger variations are harder to explain. Isolate 3893 exhibited non-specific agglutination in non-immune European serum in the first but not the second experiment. Agglutination of this isolate was also lost in 4 other plasmas. It seems likely that the agglutination observed in the other plasmas initially was also non-specific and may be weaker and more prone to variation than specific antibody-mediated agglutination. Whatever the underlying cause, this experiment indicates that agglutination assays are inherently prone to a degree inter-assay variation and is consistent with previous reports by others (Aguiar, *et al.*, 1992; Reeder, *et al.*, 1994; Bull, *et al.*, 1999).

Because the mature parasites that express PIESA sequester in capillary beds and are therefore absent in the peripheral circulation, parasite samples for studies on PIESA are obtained and cryopreserved as rings and cultured to maturity when required. However, this has limitations as some cryopreserved isolates do not grow in culture upon thawing (Forsyth *et al.*; 1989; Reeder *et al.*, 1994; personal obs.) and among those that do, a substantial proportion of parasites may be lost during cryopreservation and thawing. Thus, recovery from cryopreservation could select a parasite subpopulation with altered characteristics (Jadin, *et al.*, 1976). Second, variation in the times that recovered rings from different isolates mature makes planning for experiments

involving simultaneous assaying of many isolates difficult. I observed that parasites cultured fresh from patients tend to grow well in culture for at least one generation and therefore explored the possibility of using parasites grown in fresh blood and cryopreserved as mature parasites in agglutination assays and flow cytometry.

I was able to recover up to 83% of the cryopreserved schizonts in contrast to previous reports of the preferential recovery from cryopreservation of rings over mature parasites (Diggs, *et al.*, 1977; Wilson, *et al.*, 1977; Margos, *et al.*, 1992). I examined the effect of cryopreservation on PIESA phenotype in two ways. First, I used the mixed agglutination technique to determine if the variant specificity of the parasite antigens involved in agglutination was retained or lost. Although the three laboratory isolates used for the experiments are part of the same IT/4/25/4 clone tree, they do not exhibit mixed agglutination, indicating that the targets of agglutinating antibodies on them vary and also underlining the variant-specificity of agglutination assays. The observation that cryopreservation of these isolates did not result in increased mixed agglutination between them is an indication that the variant specificity of their PIESA was unaltered. In addition, this also indicates that no novel infected erythrocyte surface antigens that might be conserved across the isolates were revealed after cryopreservation.

Second, I used an alternative approach to further confirm the observations above. I assessed the effect of cryopreservation on the flow cytometry and agglutination reactivity of 7 and 9 isolates respectively with 22 plasma samples. Overall, the variations in agglutination profiles of a panel the isolates following cryopreservation was similar to those observed in the inter-assay experiment and could be explained thus. No systematic bias in the agglutination of schizonts

from either of the sources was observed. The loss of non-specific agglutination following cryopreservation could have contributed to variations in the agglutination profiles of some isolates (va7, va8, va12 and 13)

The lower parasitaemia in CS compared to the corresponding fresh samples indicates that some parasites may have been lost during cryopreservation. However, the lack of significant alteration in the proportion of infected cells in each isolate reacting positively with each of the test plasmas on the flow cytometer before and after cryopreservation suggests that the overall population constitution of each isolate was not altered. The decreased MFI in CS suggests that some degree of cell membrane alteration occurred on the remaining cells affecting the amount of antibody that bound to the cell surface cytometer assay. Both temporary and permanent damage in red cell membrane ultra-structure following cryopreservation has been reported (Diggs, *et al.*, 1977) As such, caution needs to be exercised when using CS for flow cytometry if MFI is the parameter of interest. The source of schizonts in each section of this study is indicated in the description of the experimental design. Failure to grow in culture confirms the schizonts suffered irreversible damage during cryopreservation. The use of different freezing protocols to try to improve viability of CS (Margos, *et al.*, 1992) will be explored in future.

Taken together these data suggests that cryopreservation does not affect the variant specificity of PIESA and as a result, the agglutination phenotype of malaria parasites cryopreserved as schizonts is not altered. However, there may be some alterations on the infected cell surface that could result in reduced surface immunofluorescence. As such, CS could be suitable for

determining PIESA phenotype by agglutination and flow cytometer when percent cell positive is the parameter of interest but caution should be exercised where MFI is the parameter of interest.

In order to facilitate the interpretation of flow cytometry results, I assessed the relationship between both MFI and percentage of infected cells staining positive with FITC with antibody titres. Because antibodies against the test isolates titred out by the 4th dilution (1:100) of the plasma, the calculation for correlation was based on a few points. Nevertheless, within this dilution range, a strong correlation was observed between both flow cytometry parameters and antibody titres. However, the percentage of A4 cells positives was less well correlated with titre than MFI was and the reason appears to be a dip in the parasitaemia detected in the 1:5 serum dilution reaction sample. Microscopic examination of this sample revealed agglutination of the parasites, which would explain the drop in the apparent parasitaemia. It seems likely that agglutinates might interfere with flow cytometry if parasites are assayed at a high parasitaemia. Therefore, subsequent assays were done with parasite samples at a lower parasitaemia. In view of these results, either of the two flow cytometer parameters could be taken as proxy measures for titre.

Finally, I also explored the relationship between data from flow cytometry and agglutination assays. Although a level of overlap between two assays is expected, variations could arise because of differences in the sensitivity and specificity of the two methods. Furthermore, whilst all the antibodies leading to agglutination ought in theory to be detectable by flow cytometry, the reverse does not follow, since not all specificities may have the same capacity to cause agglutination and surface fluorescence has been reported on schizont infect cells that failed to

agglutinate (Barnwell, *et al.*, 1983). The correlation between the parameters varied between isolates although on whole agglutination correlated better with percent cell positive than MFI. This is not surprising as the method of scoring agglutination used here estimated the total number of cells that were agglutinated and were therefore a subset of all the cells that have antibodies on their surface. MFI, which is potentially an indicator of how much antibody is bound to the cell surface, was less well correlated with agglutination. It is possible there is a minimum threshold of amount of antibody surface binding required to maintain stable agglutinates beyond which any increase, though resulting in increased MFI, will not affect agglutination levels. However, such a threshold was not evident in these data.

**THE NATURAL HISTORY OF IMMUNE
RESPONSES TO MALARIA**

SAMSON MUCHINA KINYANJUI

DOCTOR OF PHILOSOPHY THESIS (2001)

Volume 2

2.6 LONGITUDINAL STUDIES.

Two longitudinal study frameworks were used in the work described in this thesis.

Kinetics of anti-PIESA responses (chapter3).

For this part of the studies, children who had a primary diagnosis of malaria but who did not fulfill the WHO (2000) criteria for severe malaria were recruited during admission to the paediatric ward of Kilifi District Hospital. Children who had a haemoglobin level below 4g/dl and were therefore likely to be receive a blood transfusion during their stay in hospital were excluded from the study

A 2-3 ml blood sample was obtained from the child by venepuncture on the dorsum of the hand or the ante-cubital fossae upon a written consent from the accompanying guardian. The guardian was then given a card indicating the date they were requested to bring the child back for convalescent sample collection

Children whose condition subsequently deteriorated to encompass the criteria for severe malaria or who received a blood transfusion were excluded from the study

The study was carried out in two phases, in the first phase, (July 1997 – October 1997) convalescent samples were obtained 1, 2, 3, and 6 weeks after treatment while in the second phase (July 1998- January 1999) they were obtained 1, 2, 3, 6, 9 and 12 week after treatment.

During the convalescent visits, the children were examined by a clinician, laboratory tests including a malaria slide done and appropriate treatment given for any complaints.

Children who failed to turn up within two days of the appointed day were followed up at home and were considered lost to follow-up if no samples could be obtained at two consecutive time points.

The dynamics and protective role of anti-PIESA responses

As mentioned in the declaration, these studies were conducted within a larger longitudinal study framework that was designed to look at the epidemiology of mild malaria in Kilifi over a period of two years. Both the principal investigators in the mild malaria study and I were equally involved in the setting up of the longitudinal study framework.

Study population and subject selection

The studies were carried out in Ngerenya location that is part of the Northern study area as indicated on the map in the methods sections (Fig. 2.1). Re- enumeration of all the people residing in the area was done to update the census list before the selection of study subjects. 40 households were randomly selected from a map drawn during the setting up of the study area in 1992 (Snow, *et al.*, 1994). In total about 540 individuals; about half of who were children below the age of 10 years were included in the study.

Informing the target population of the study plans and consenting for the study.

Information concerning the study was passed on to the target community in two stages. Before beginning the recruitment drive, we held meetings with the administrative officials and community leaders of Ngerenya location, informed them of our intentions to carry out the studies, and explained the details of the studies. Next, we held similar meetings with parents, teachers, and pupils in schools around the location. During the recruitment process, a team of trained field workers visited the household where the selected individuals resided and explained the study to them or their guardian in a local language. After the information, individuals were given the opportunity to ask questions and then decide if they would consent to their children or themselves being in the study. If they did, they were requested to sign a consent form on their own or their children's behalf

Cross-sectional survey

At the beginning of the follow-up period (September 1997), all the participants were invited to attend the hospital for an initial cross-sectional survey. During the survey, 2-5ml of blood were obtained by venepuncture. A 1ml aliquot was placed in a serum separator microtainer tube while the rest was placed into a 15ml tube containing 50ul of heparin and taken to the laboratory for plasma separation by centrifuging. The plasma obtained was stored at -20°C . In addition, a full examination including a malaria slide and body temperature reading was done by a doctor and all histories of fever recorded. Appropriate treatment was given for any condition that was diagnosed. A second survey on a selected group of 130 individuals was carried out at the end of the 1st year. The selection was done to include all individuals who during the year presented with three or more episodes, and a proportion of those who had had two, one, or no episodes.

Active and passive surveillance of malaria episodes

All the participants were actively monitored for malaria episodes for a period of two years. During this period, field workers visited each participant once a week and recorded their body temperatures, and noted any history of fevers in the preceding 24 hours. Anyone with current fever (auxiliary body temperature ≥ 37.5) was given bus fare and requested to go to a special study clinic at the hospital immediately. At the hospital, further examination including a full blood count and a malaria slide was carried out and appropriate treatment given. For individuals who gave a history of fever in the preceding 24 hours, a malaria smear was made from a finger-prick blood sample and taken back to the lab for examination. In order to ensure that no fevers were missed between the field worker visits, all participants were asked to report to the study clinic any time they had any health complaint. Individuals who were inaccessible to the field workers for more than three weeks were withdrawn from the study

Data storage.

Both field and hospital surveillance data were recorded on specially designed forms before being double entered and verified in a FoxPro data base on IBM-compatible personal computers at the Center.

CHAPTER 3

THE KINETICS OF ANTIBDOY RESPONSES TO PIESA

3.1 INTRODUCTION

Several studies have shown that most individuals can make humoral responses to PIESA (Forsyth, *et al.*, 1989; Aguiar, *et al.*, 1992; Iqbal, *et al.*, 1993) and that these responses may protect against malaria in a variant-specific manner (Marsh, *et al.*, 1989; Bull, *et al.*, 1998; Giha, *et al.*, 2000; Dodo, *et al.*, 2001). However, most of the studies on PIESA have assessed responses to parasite isolates from sources that are different from that of the sera (heterologous), or to autologous parasites for only a short period after an episode. Such studies can only assess residual markers of a response but shed relatively little light on its natural history. As a result, no data are available on the kinetics of anti-PIESA response to the autologous parasites an acute episode of malaria. The aim of this study was therefore to describe the rate, magnitude, and isotype profiles of anti-PIESA antibody responses to autologous parasites in children following an acute episode of malaria.

3.2 STUDY DESIGN

Patients and blood sampling

Plasma samples obtained from children convalescing from an acute episode of malaria were assayed for agglutinating antibodies directed against PIESA of the parasite that had caused the episode. The study was done in two phases, the first between July 1997 – October 1997, and the second between July 1998 and January 1999. During the first phase, plasma samples were

obtained 1, 2, 3, 6, after treatment while in the second phase the follow-up was extended to 9 and 12 weeks. Details of the study frameworks are given in section 2.6.

Agglutination assays

Each child's set of plasmas from different time points was titrated for agglutinating antibodies against the autologous parasite isolate. The plasmas were at first diluted in sera from Europeans with no prior exposure to malaria (non-immune) and then a further 1:5 dilution was done in RPMI so that the final assay dilutions were 1:5, 1:25, 1:50, 1:100, and 1:200. In the first phase, some of the assays were done on parasites grown to maturity from cryopreserved rings, while the rest were done on parasites that were grown fresh from patients and cryopreserved as mature parasites. All the assays in the second phase used cryopreserved mature parasites. The suitability of cryopreserved schizonts as a source of parasite material in agglutination assays was assessed and is described in section 2.4.

Reading of the assay slides differed slightly between the two phases: in the first phase, agglutinates were first sought in every third field. If no agglutinates were found in this run was the whole slide re-read considering all the fields; in the second phase, all the fields were read in the first run. The highest dilution at which agglutination was positive was taken as the titre of agglutinating antibodies in the sample. Pooled non-immune European sera and RPMI without plasma were included as negative controls to assess non-specific agglutination.

Flow cytometry

The isotypes of the PIESA antibodies were assessed by flow cytometry as per the described protocol (chapter 2). The percentage of cells positive was taken as a proxy measure of antibody titre.

Data analysis

Data was stored, formatted, and analysed with Microsoft Excel. Further analyses were done using Stata. Where proportions have been compared, Fischer's exact test was used.

3.3 RESULTS

General results

48 children were recruited in the first phase, 6 of these were lost to follow-up, parasites from 9 children failed to grow in culture after recovery from cryopreservation while parasites from 6 other children failed to agglutinate even in pooled immune serum that agglutinates most isolates from Kilifi. 5 isolates exhibited non-specific agglutination. Therefore, data from 22 children were included in the analysis. In the second phase, 48 children were recruited, 6 of who were lost to follow-up, 13 isolates either failed to grow properly or looked damaged upon recovery from cryopreservation, while another 5 exhibited non-specific agglutination. Consequently, data from 26 children were analysed. The flow cytometer became available at Kilifi sometime during the second phase of the study and due to lack of parasite material, isotype analysis was done for responses in 11 children only.

Prevalence of antibodies to autologous parasites over time. (Fig. 3.1)

About a third of the children had agglutinating antibodies to the infecting parasite at the time of admission to hospital; this proportion increased to over 80% by the second week and remained above 80% for the next 10 weeks (Fig. 3.1A). The geometric mean titres also followed a similar trend showing a sharp rise between the time of admission and the second week (Fig. 3.1B). The peak at week 2 was followed by a dip until the 6th week, a slight rise occurred in the 9th week after which the titres continued to fall. Both the percentage of children who were positive at each time point and the titres of antibodies were lower among children from the first phase compared to the second but showed similar trends.

Figure 3.1

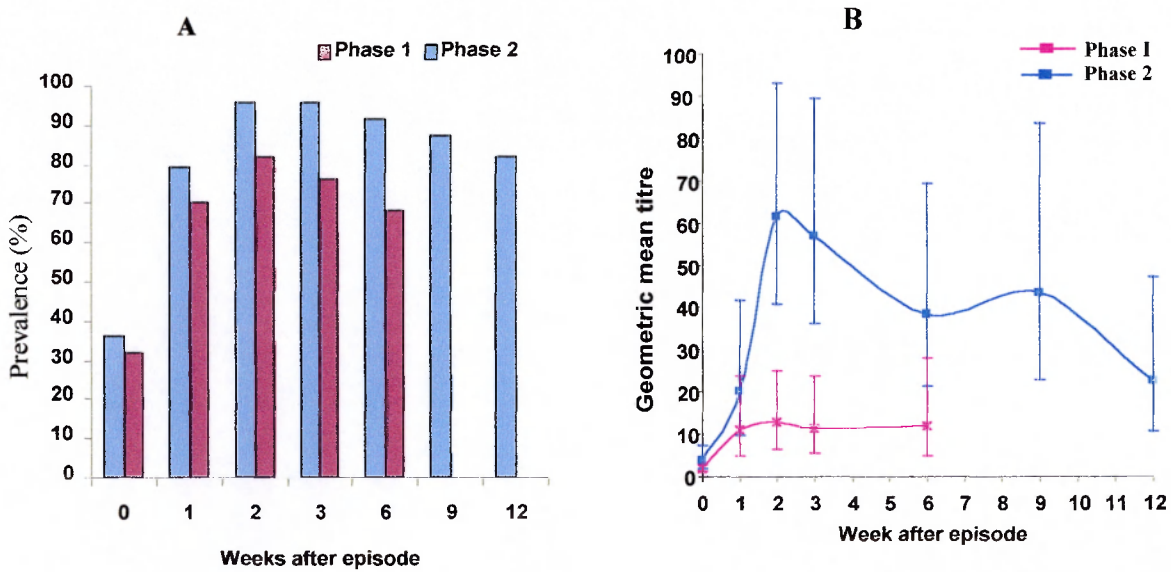

The prevalence (A) and geometric mean titres (B) of agglutinating antibodies to autologous parasites at various time points after the episode.

Isotypes profiles of anti-PIESA antibodies. (Fig. 3.2)

Plasma samples from 11 children were analysed by flow cytometry to determine the isotypes of PIESEA antibodies. Although individual profiles varied in magnitude of response, in general, IgM dominated the early response and increased to a peak in the first two weeks after which the titres dropped sharply in the third week before decreasing more gradually through the rest of the study period. IgG3 dominated the IgG responses rising to a peak in the first two weeks, which was followed by a gradual decline in the next 11 weeks. Except for a slight peak in week 2, IgG1 titres were generally low throughout the study period. Both IgG2 and IgG4 titres also remained low throughout the study period. One child (no. 49) differed slightly in that early responses were dominated by relatively high titres of IgG3 while levels of IgG1 also rose rapidly and continued to rise for the next 12 weeks.

Factors influencing rate and magnitude of response

Logistic regression was used to determine what factors influenced the time to sero-conversion and the highest titres achieved. Age, parasitaemia at admission, assay parasitaemia or area of residence of the children did not influence these two parameters

Figure 3.2

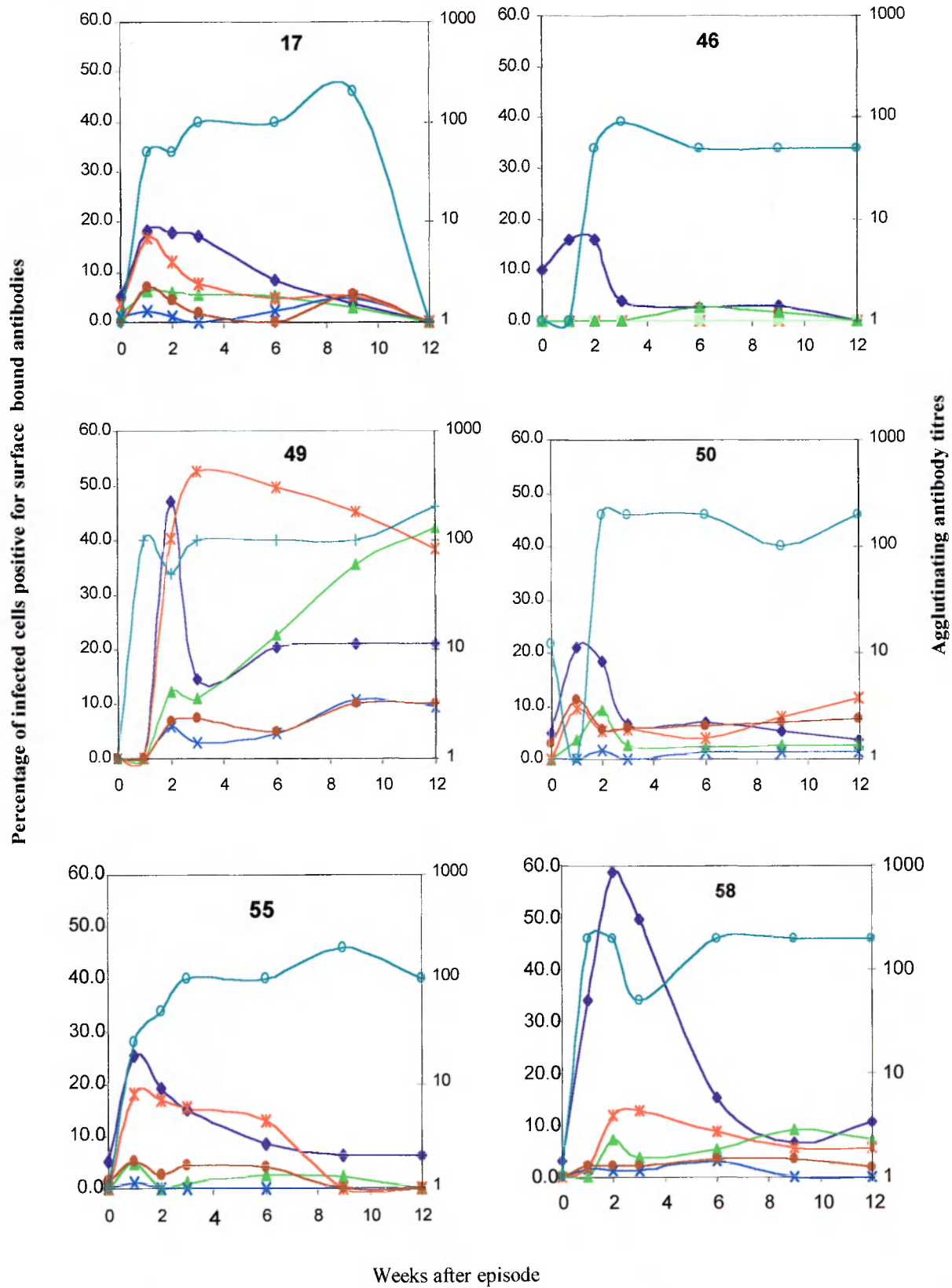

◆ IgM ▲ IgG1 X IgG2 * IgG3
● IgG4 ○ Agglutination

Figure 3.2 cont'd

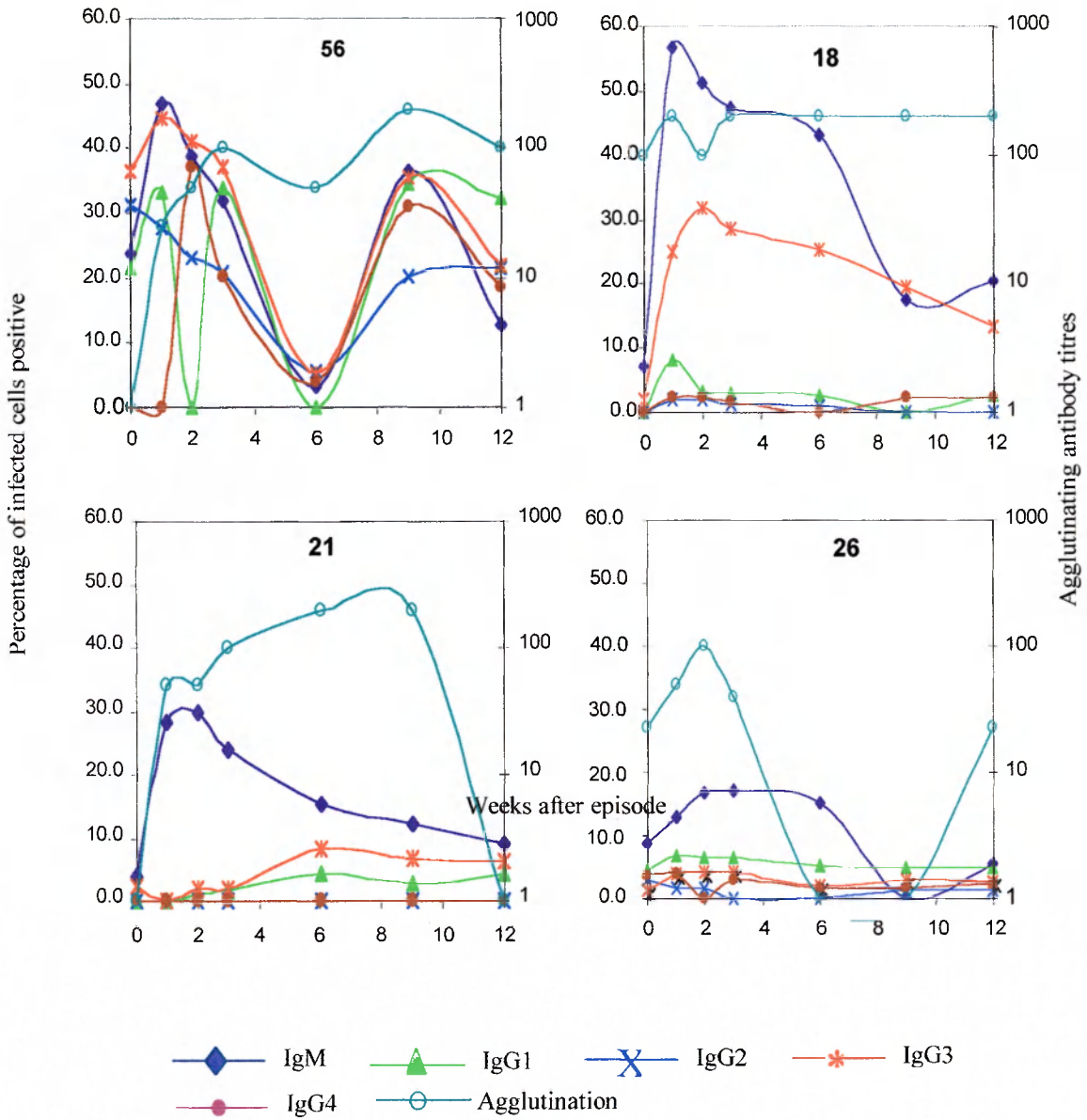

Individual isotype - time profiles, child number 18 was classified among the second group with respect to agglutinating antibody profile, while 21 and 26 were in the third group, the rest of the children were in the first group

Individual agglutination profiles. (Fig. 3.3)

The children exhibited wide variations in their agglutination antibody profiles. I first assessed the profiles visually and grouped together children who had similar profiles. Three groups became apparent when I did this. Figure 3.3 shows the plots of agglutination profiles of all individuals in each group, and the corresponding antibody isotype profiles for the children in each group. These groups were apparent in both phases of the study despite the fact that lower antibody titres were observed in children during the first phase.

Children in the first group had no agglutinating antibodies at admission, but they showed a rapid increase in antibody titres in the first two weeks after which the titres remained constant through week 12. Eleven (50%) children in the first phase and 14 (54%) in the second fell into this group. The second group consisted of 5 (one from phase 1) children who already had agglutinating antibodies to the infecting parasite at the time of admission and in whom antibody titres remained high throughout the study period. Isotype profiles from children in these groups were consistent with a primary response with IgM dominating the early part of the responses and IgG subclasses the later part. In the third group, 18 (40%) consisting of 11 (50%) children in phase 1 and 7 (26%) in phase 2 responses appeared to be transient, with antibody titres being generally lower than in the first two groups and disappearing at various time points during the study. Responses from two children (no 21 and 26) in this were dominated by IgM response while IgG responses remained very low through out the study period

Figure 3.3

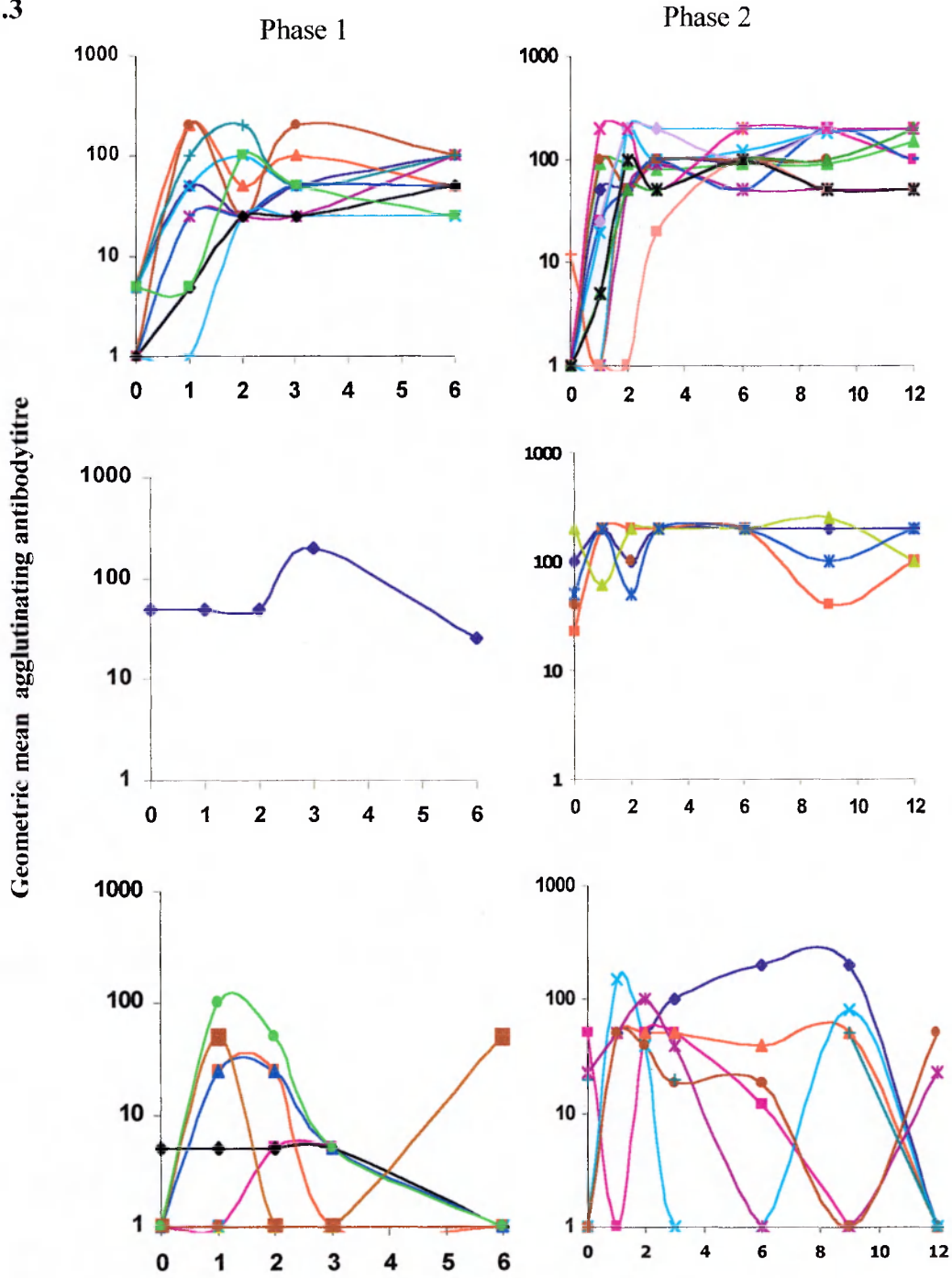

Agglutinating antibody profiles of all the children from the two phases (A and B) categorised into three groups of similar profiles. Each line represents an individual child's profile.

Antibody profiles and re-parasitisation.

I monitored re-parasitisation of the study children by preparing malaria slides during each convalescence visit. It was not possible to distinguish between recrudescence and re-infection, or to determine the phenotype of the emergent parasites as the parasitaemia were too low for culturing. During the first phase, two children returned with parasitaemia, one in the third, and one in the sixth week. 11 (42%) children presented with parasitaemia at various time points during the second phase of the study. One child became parasitaemic within two weeks of the initial episode, 3 children in the third week, while 6 more children were parasitaemic at week 6, 9, or 12. The majority (71%) of children in the third response profile group were re-parasitised during the study while only 6 out of 19 (31%) in the other two groups were (Odds ratio = 5.42, C.I. 0.62 – 57.87, P= 0.085).

3.4 DISCUSSION

The ability of individuals from malaria endemic areas to respond to PIESA has been demonstrated frequently. The protective role of antibodies to these antigens has also been demonstrated. However, most of the studies on PIESA have been cross-sectional or longitudinal studies restricted to three weeks after an episode. No data is available on the kinetics of response to PIESA. In this study, I looked at the rate, magnitude, and quality of anti-PIESA response in children recovering from an acute episode of uncomplicated malaria.

The majority of children in this study developed agglutinating antibodies within two weeks of an acute malaria episode. This confirms the immunogenicity of PIESA and is consistent with

previous reports (Marsh and Howard, 1986; Forsyth, et al., 1989; Iqbal, et al., 1993; Reeder, *et al.*, 1994; Bull, et al., 1998). The prevalence of these responses remained high even ten weeks after the clinical episode with which they were associated. The mean titre on the other hand rose sharply during the first two weeks then dipped slightly until the sixth week. A slight rise was observed in week nine then the titres continued declining. This kinetics profile is similar to that of SICA antibodies observed in *P. knowlesi* infections in rhesus monkeys (Butcher and Cohen, 1972). There was a significant difference between the magnitude of responses observed in the first and second phases of the study. No good explanation could be found for this although it is possible that differences in the way the agglutination slides were read in the two phase may have had a contribution.

The isotype profiles of responses in 11 of the children were typical of a primary antibody response with IgM dominating the early part of the responses and IgG gradually taking over later and corresponded with the profile of agglutinating antibodies. The peak in agglutinating antibody titres at week 2 corresponds with the IgM and IgG3 peak while agglutination beyond this point seems mediated by IgG3 and the decreasing IgM antibodies. IgM's short half-life compared to IgG's would explain why other studies using heterologous isolates failed to observe its involvement in agglutination and surface immunofluorescence assays (Piper, *et al.*, 1999b).

The predominance of IgG3 is typical of responses to many malaria antigens (Beck, *et al.*, 1995a; Taylor, *et al.*, 1995; Rzepczyk, *et al.*, 1997). *In vitro*, cytophilic antibodies have been shown to co-operate with monocytes in inhibiting parasite growth and promoting phagocytosis while IgG2 and IgG4 appear to antagonise this co-operation (Bouharoun-Tayoun, *et al.*, 1990; Bouharoun-Tayoun, *et al.*, 1992). Correlation between protection against malaria morbidity and malaria-

specific cytophilic antibodies has also been reported (Salimonu, *et al.*, 1982; Aribot, *et al.*, 1996; Ferreira, *et al.*, 1996; Sarthou, *et al.*, 1997). Although IgG3 persisted beyond 12 weeks in the children, it has a relatively shorter half-life than the other IgG subclasses and might require constant boosting to maintain protective levels. The skew of responses to PIESA towards the short-lived IgG3 antibodies might help explain the seasonal variation in PIESA antibody levels observed in studies (Giha, *et al.*, 1998) elsewhere and also by ourselves (chapter 4).

When considered individually, the children exhibited considerable variation in the kinetics of the responses to PIESA. These variations may reflect differences in host factors such as the levels of development of malaria immunity or genetic makeup. They could also reflect varying ability of different PIESA variants to provoke immune responses. I placed the children into three groups based on similarities in their agglutinating antibody profiles. The first group comprised about half the children in the study. These children had no agglutinating antibodies at time of admission, but they showed a rapid rise in titres within the first two week, and subsequently maintained the antibody levels through week 12. The domination of IgM in the early part of the response in 6 children from this group nonetheless indicates that the responses were primary.

Children in the second group were able to agglutinate the infecting parasite at the time they were admitted to hospital. This may seem surprising, given that Bull *et al* (1998) have showed that children are unlikely to be infected by parasite against whose PIESA they already had antibodies. Only samples from one child in this group were analysed by flow cytometry for isotype profiles and it was therefore not possible to draw any firm conclusions. Nevertheless, in this child, the isotype profile was more consistent with a primary rather than a secondary response with IgM

peaking in the first week after the episode and IgG3 a week later. This suggests that these children either mounted a more rapid response or had had a longer period of exposure to the parasites before the time that the acute plasma sample was taken.

The third group consisted of children in whom the responses did not follow the typical profile observed in children in the other two groups. Responses in many of these children were low and short lived. In some of the children, the responses disappeared completely during the study period while in a few others they seem to disappear and then reappear sometime later. IgM dominated responses in two children in this group while IgG was poorly induced throughout the study period. Although it is not possible to tell if these isotype profiles were typical of responses in all the children in this group, the observation of such profiles nonetheless raises the possibility that some children may fail to respond adequately to some PIESA variants. Whether this is due to host or parasite factors is an interesting question. Children in this group appeared to have an increased risk of becoming re-parasitised during the study period. However, the increase was not significant, and these observations would need to be verified in a larger study. Even if these observations were true, it would still not be possible to attribute wholly the increased risk of re-infection to inadequate anti-PIESA responses without also examining the children's capacity to respond to other malaria antigens.

In summary, this study reveals a number of aspects of the kinetics of anti-PIESA responses in children. First, the majority of the children are able to mount some level of antibody responses against PIESA but they exhibit varying profiles of response over time. Analysing samples taken at only one time point would not reveal such differences and hence the importance of

longitudinal monitoring of responses. Second, while the many of the children appear to make a rapid and persistent response to PIESA, a number of children appear to have inadequate short-lived responses. It is possible that some of these children fail to switch to IgG after the initial IgM responses. These children also appear to have an increased risk of becoming re-parasitised earlier than the more the rest of the children. However, these observations will require further studies to verify. Third, IgG3, which was the dominant anti-PIESA IgG subclasses, persisted beyond 12 weeks and may therefore overlap with new infections that could boost its levels through cross-reactive or secondary responses. Finally, although agglutination assays and flow cytometry data do not correspond very well at individual levels, they do at a general level thus the former method may be used to provide data on kinetics of responses against *P. falciparum* schizont surface antigens where the more expensive flow cytometer is unavailable.

CHAPTER 4

THE DYNAMICS OF THE ANTI-PIESA REPOSES OVER TIME

4.1 INTRODUCTION

The role of anti-PIESA antibodies in mediating protection against malaria episodes has been demonstrated in Gambian (Marsh, *et al.*, 1989), Kenyan (Bull, *et al.*, 1998) Ghanaian (Dodoo, *et al.*, 2001) children, and in Sudanese individuals (Giha, *et al.*, 2000). Since these antibodies are variant specific, the period required by individuals to reach an immune state is thought to reflect the time required for the accumulation of antibodies to the majority of locally circulating PIESA variants (Gupta and Day, 1994). This concept is supported by the fact that in endemic areas, the number of variants that an individual is able to agglutinate correlates with age (Bull, *et al.*, 1999).

Although the induction of antibodies against both homologous and heterologous (different from the one causing an episode) variants during an acute malaria episode has been reported (Bull, *et al.*, 1999; Giha, *et al.*, 1999), the dynamics of accumulation of these specificities over time are poorly documented. The only published observations available are from the Sudan (Giha, *et al.*, 1998). However, Daraweesh, the area in which the study was done, has a short and very seasonal transmission period and hence the majority of the people have limited clinical immunity to malaria, even as adults. It is not known how the dynamics of acquiring anti-PIESA antibodies vary under different transmission and immunological backgrounds. This study therefore aimed at clarifying the role of both clinical and sub-clinical infections in

the acquisition and persistence of anti-PIESA antibodies in children living in an area with moderate to high malaria transmission.

4.2 STUDY DESIGN

Paired plasma samples obtained from 119 children at the beginning and the end of a one year follow-up period (see details in section 2.6.) were assayed for anti-PIESA antibodies to a panel of laboratory and field isolates by agglutination and flow cytometry. The changes in the children's antibody repertoire were assessed for relationship with the children's age and clinical experience of malaria during the longitudinal study. A clinical episode was defined as having an axillary body temperature of 37.5⁰C or above in the presence of 5000 or more parasites per microtitre of blood.

Agglutination and flow cytometer assays

48 paired plasma samples were assayed for agglutinating antibodies against a panel of 9 isolates (6 field isolates, and 3 lab isolates –A4, ITGIC5, C10). Details of the source of the field isolates; age and clinical history of donor are presented in table 4.2A. With each isolate, all the 48 plasma pairs were assayed at the same time and the slides read blind on the same run to avoid inter-assay variations.

A second set of 71 plasma pairs from children, 10 years and younger, including the 48 whose plasma was also assayed for agglutinating antibodies, were assayed for anti-PIESA IgG antibodies against a further panel of 6 isolates (details in table 4.2B) by flow cytometry. The selection was such that plasmas from all children who had three (n=10) or more malaria episodes, and a portion of those who had two (n=18), one (n=22), or no episode (n=21)

during the year were included. For the purpose of analysis children who suffered at least one episode during the follow-up year were designated as “cases” and those who did not were designated as “controls” Roughly an equal number was selected for four two-year age categories. The number of children in each category is given in table 4.1 below.

Table 4.1

Age (months)	0-23	24-47	48-71	>72
Agglutination	14	11	12	11
Flow cytometry	15	17	18	21

The number of children in each age category whose plasma was assayed by agglutination or flow cytometry

Data analysis

Agglutination reactions were scored as described earlier, and the data illustrated on a checkerboard for visual examination. The percentage of infected cell staining positively with FITC for antibodies bound on their surface on flow-cytometer was used as a proxy measure for antibody titres with any score below 5% being considered negative. Where proportions have been compared, Chi-squares analysis for differences was done using Intercooled Stata 6 (Stata corporation, Texas, USA).

4.3 RESULTS

Prevalence of antibodies to the test isolates at the first survey. (Table 4.2)

In both agglutination and flow cytometer assays, there was considerable variation in the prevalence of antibodies to each of the test isolates. Some isolates such as 1542 and 3940 (table 4.2A) and isolates 3661 and 3076 (table 4.2B) were recognised by the majority of children. On the other hand, many of the children failed to react positively with isolate B7 and the laboratory cloned isolate C10. Despite variations during the year, the relative prevalence of antibodies to the isolates remained similar at the beginning and end of the year. Overall, the prevalence of antibodies to the test isolates was higher among the controls than among the cases. The average titre was also higher among the controls. However, these differences were not significant. A more comprehensive assessment of the correlation between anti-PIESA antibodies and protection against malaria within this group of children is described in chapter 5.

Correlation between the prevalence of specific anti-PIESA and age

Agglutination (Fig. 4.1A)

Except for isolate 3661 and 3076 which were agglutinated by most children regardless of age, the prevalence of agglutinating antibodies to given isolate increased with age, though the rate of increase varied among the isolates. While the prevalence of anti-B7 antibodies increased from 4% to 14%, between the ages of 0-2 years and over 8 years, the prevalence of antibodies against isolate 3026 rose from 30% to 85% and that of antibodies to ITGIC5 increased 8-fold from 7% to 57%. A slight dip was observed in the percent of children agglutinating isolate 4386 after the age of 6-8 years.

Flow cytometry (Fig. 4.1B)

The prevalence of antibodies to isolates A4, 1541, 3893, and 3944 increased with age. The age-prevalence pattern was most distinct in the case of isolate 3944. Most of the children in this study agglutinated the other two isolates (1542, and 3940) regardless of age.

Figure 4.1

A

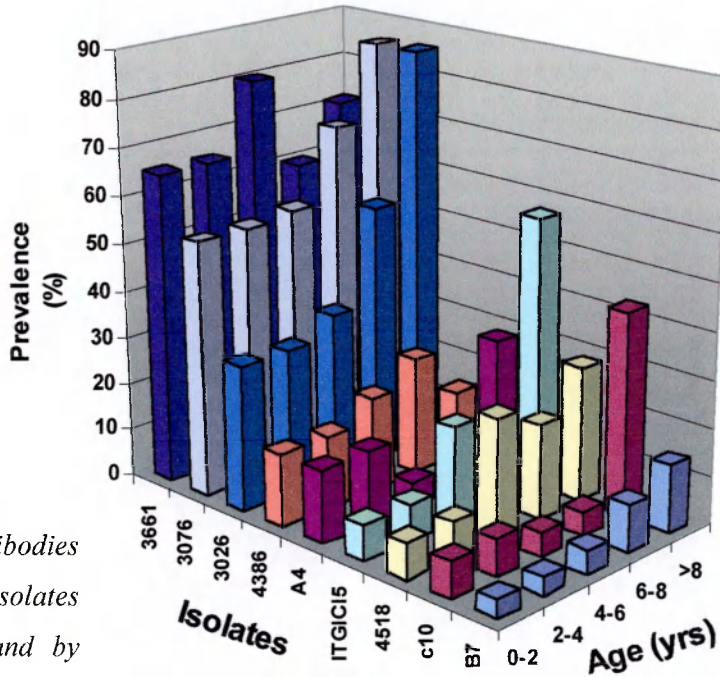

Age-prevalence plots for antibodies against PIESA of various isolates assayed by agglutination (A) and by flow cytometry (B)

B

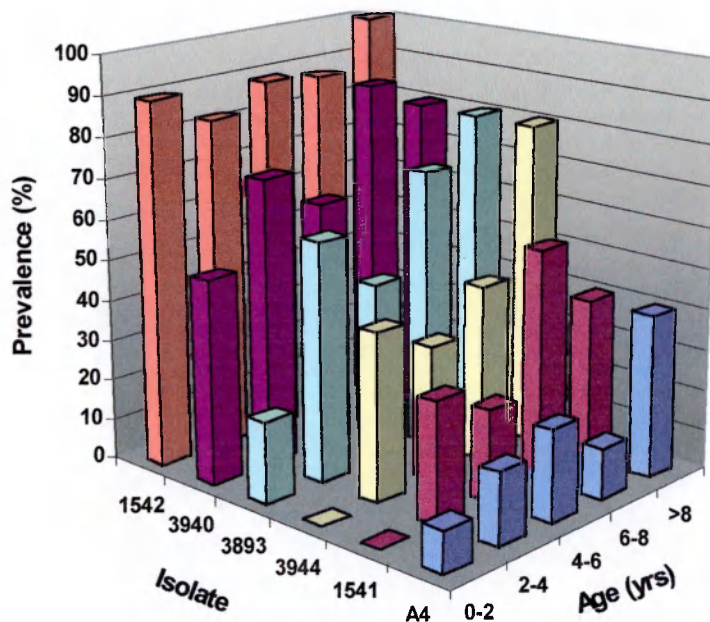

Variation in Anti-PIESA antibodies repertoire over a one-year period (Tables 4.2A & B).

Changes were observed in the prevalence of antibodies to all the isolates between the first and second bleed. These variations have been considered at two levels: those resulting in the acquisition of novel specificities or complete loss of pre-existing ones and those resulting in a partial loss or boosting of pre-existing agglutinating antibodies

Table 4.2A

Isolate	A4	1541	3944	3893	3940	1542
Age of donor (months)		48	47	24	48	19
Clinical history of donor		Mild	Severe	Severe	Mild	UC
Mean age of +ve at 1 st bleed \pm SD (months)	50 \pm 37	55 \pm 32	60 \pm 34	58 \pm 31	54 \pm 31	52 \pm 31
Positive at 1 st bleed	19 (26.8)	24 (33.8)	25 (35.2)	36 (50.7)	49 (69.0)	63 (88.7)
Positive at 2 nd bleed	14 (19.7)	27 (38.0)	17 (23.9)	25 (35.2)	55 (77.5)	52 (73.2)
Complete loss of Antibodies by end of year	12 (63.2)	11 (45.8)	14 (56.0)	21 (58.3)	8 (16.3)	17 (27.0)
Sero-conversion	7 (13.5)	14 (29.8)	6 (13.0)	10 (28.6)	14 (63.6)	6 (75.0)
Partial loss of antibodies	2 (10.5)	4 (16.7)	3 (12.0)	8 (22.2)	20 (40.8)	24 (38.1)
Boosting of existing responses	1 (5.3)	4 (16.7)	3 (12.0)	3 (8.3)	6 (12.2)	5 (20.8)

Summary data of the dynamics of anti-PIESA responses to 6 isolates assayed by flow Cytometry. Sero-conversion is the percentage of children who were initially negative that became positive by the end of the study. Clinical history of donor indicates the severity of the malaria episode during which the isolate was obtained. UC- uncomplicated. Percentages are given in parenthesis.

Table 4.2B

Isolate	B7	C10	A4	ITGIC15	4386	4518	3026	3076	3661
Age of isolate donor (months)	38	-	-	-	38	4	26	49	31
Clinical history of donor	UC				Severe	Severe	UC	Severe	UC
Age of positive at 1 st bleed (months) ± SD	95±25	78 ± 38	45 ± 30	75 ± 31	59 ± 22	59 ± 20	72 ± 30	47 ± 30	45 ± 31
Positive at 1 st bleed	2 (4.2)	4 (8.3)	5 (10.4)	7 (14.6)	7 (14.6)	5 (10.4)	14 (29.2)	36 (75.0)	39 (81.3)
Positive at 2 nd bleed	3 (6.3)	4 (8.3)	5 (10.4)	5 (10.4)	9 (18.8)	9 (18.8)	19 (39.6)	24 (50.0)	29 (60.4)
Sero-conversion	2 (4.3)	3 (6.8)	4 (9.3)	1 (2.4)	7 (17.1)	7 (16.3)	10 (29.4)	6 (50.0)	3 (33.3)
Complete loss of antibodies	1 (50.0)	3 (75.0)	4 (80.0)	3 (60.0)	5 (71.4)	3 (60.0)	5 (35.7)	18 (50.0)	13 (33.3)
Partial loss of antibodies	0 (0.0)	0 (0.0)	0 (0.0)	0 (0.0)	0 (0.0)	1 (20.0)	3 (21.4)	3 (8.3)	6 (15.4)
Boosting of existing responses	1 (50.0)	0 (0.0)	1 (20.0)	2 (28.6)	0 (0.0)	0 (0.0)	2 (14.3)	6 (16.7)	12 (30.8)

Summary data of the dynamics of agglutinating antibody responses to 9 isolates. Sero-conversion is the percentage of initially negative children who turned positive by the end of the study. Clinical history of donor indicates the severity of the malaria episode during which the isolate was obtained. UC – uncomplicated. Percentages are given in parenthesis.

Agglutination (Fig 4.2A &B)

There was a net increase over the year the prevalence of antibodies to isolates B7, 3026, 4386 and 4518, while the prevalence of antibodies to of children who recognised 3076 and 3661 fell by 33% and 25% respectively. There was no association between acquisition or loss of specificities and disease experience during the year. The majority (71%) of children who sero-converted to isolates 4518 and 4386 were older than 5 year ($X^2 = 8.42$ $P=0.004$) On the other hand 8/10 (80%) of those who sero-converted to isolate 3026 were below 5 years in age.

Flow cytometry (Fig 4.3A & B)

The prevalence of anti-PIESA antibodies to all the test isolates except isolates 1541 and 3940 decreased during the year. However, the variations were not significant. Neither acquisition nor loss of specificities was associated with disease experience during the follow-up period. Among the controls, the majority (84%) of children who acquired new specificities or in whom pre-existing antibodies were boosted were below the age of 7 years (OR= 6.59, 95% CI: 1.44 – 34.30, $P=0.004$).

Figure 4.2

A) Agglutination profiles of 9 isolate by plasma pairs from first (f) and second (s) survey stratified by episodes (epi) and then by age.

B) Changes in reactivity between the first and second survey

Key to A

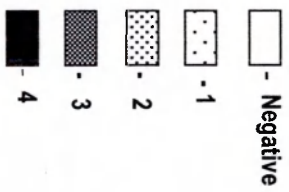

Key to B

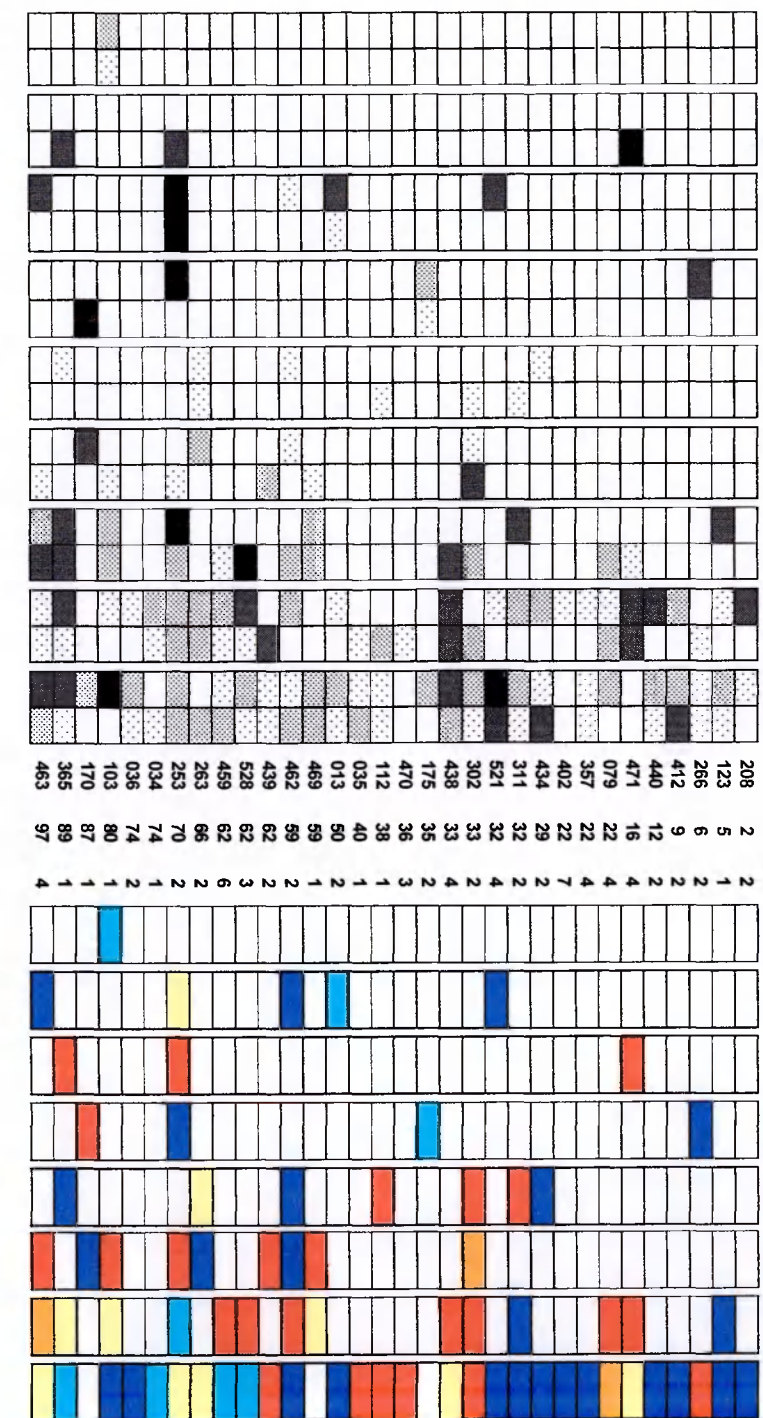
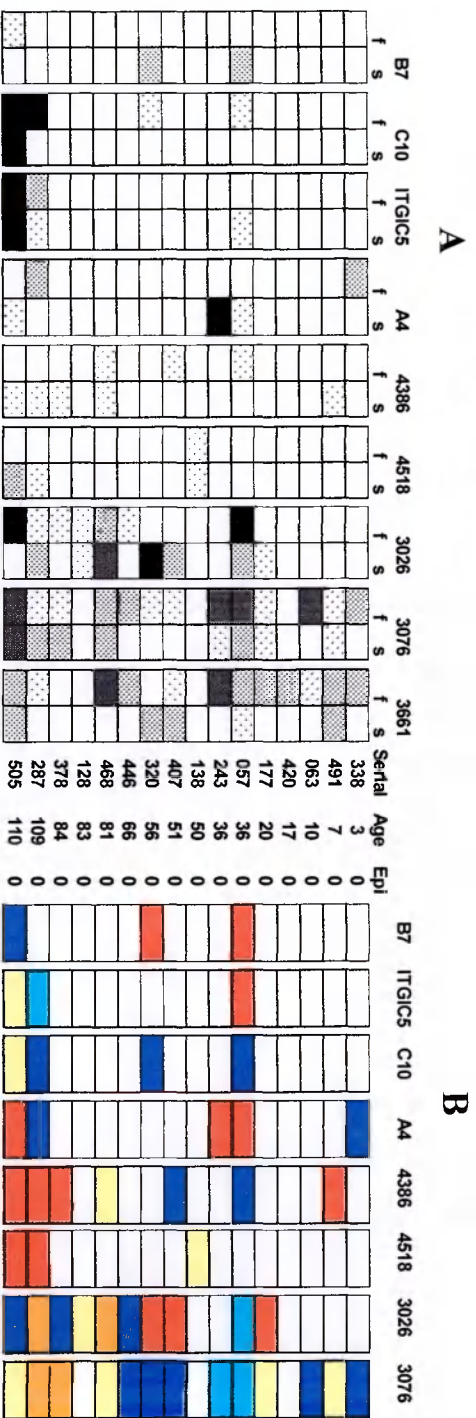
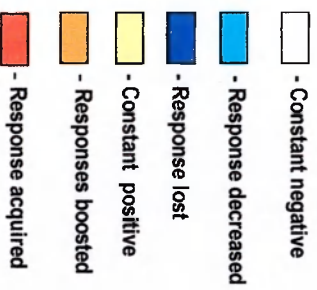
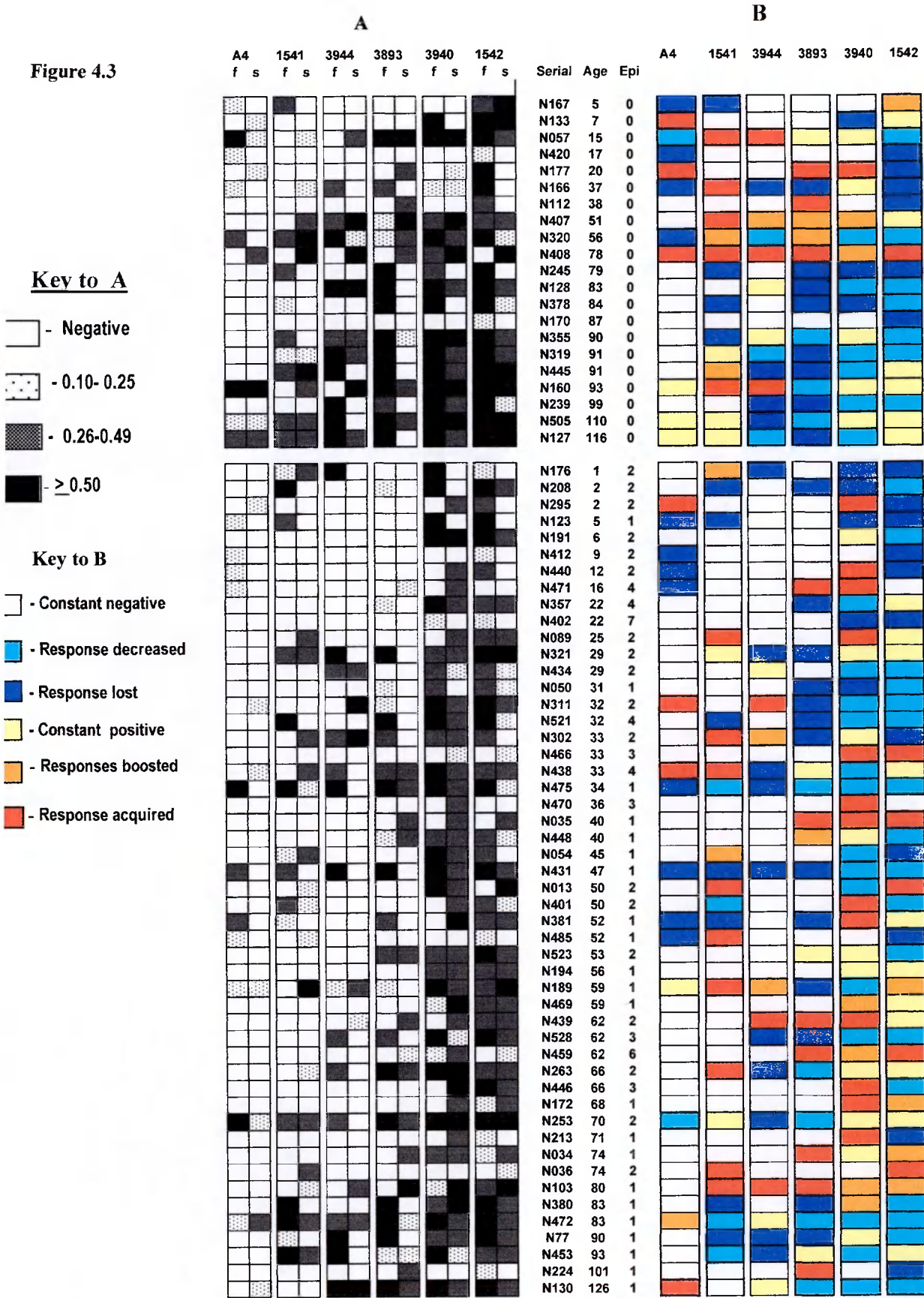

Figure 4.3



A) Surface fluorescence profiles of 6 isolate reacted with plasma pairs from first (f) and second (s) survey stratified by episodes (epi) and then by age. For each isolate, the percentage of parasites reacting positively with a plasma sample was expressed as a ratio of the percentage observed in the plasma sample that had the highest reactivity with the isolate. B) The change in reactivity between the first and second bleed

Acquisition and loss of specificities in relation to clinical experience. (Table 4.3)

I stratified the children by disease experience during the study and considered the average number of new specificities that each group gained and also the number of existing specificity that were lost the results are summarised in table 4.3. To avoid the effect of the decay of passively transferred maternal antibodies, five children who were below the age of 6 months were excluded in the analysis. The loss of specificities was higher among controls than among case but the difference was not statistically significant.

Table 4.3

	Flow cytometry		Agglutination	
	Acquired	Lost	Acquired	Lost
Control	0.80	1.35	1.07	1.33
Cases	0.85	0.94	0.90	0.90

Mean specificities acquired and lost during the study period in relation to disease experience

Acquisition and loss of specificities in relation to age. (Table 4.4)

To determine if age influenced the average number of specificities acquired or lost by an individual during the year, I stratified the children by age into three groups, those below the age of 6 months, between the age of 6 and 83 months and those above the age of 83 months. The 83 month cut off was chosen because the period prevalence of mild malaria incidences dropped significantly in individuals above this age suggesting they might be significantly

more immune than the rest (chapter 5). Children below the age of 6 months predominantly lost specificities, as did those above 83 months assayed by flow cytometry. On the other hand, children in the oldest group assayed by agglutination had higher, though not significant, loss and gain of specificities than the rest.

Table 4.4

	<u>Flow cytometry</u>		<u>Agglutination</u>	
	Acquired	Lost	Acquired	Lost
<6 months	0.40	2.60	0.00	2.30
6 –83 months	0.96	1.00	0.97	0.92
>83 months	0.31	1.31	1.50	1.50

Mean number of specificities acquired and lost during the study period in relation to age

Correlation between the initial prevalence of antibodies to each isolate and the dynamics of subsequent variation. (Fig. 4.4)

The proportion of children who sero-converted to a given isolate during the year was correlated with the initial prevalence of antibodies to the isolate ($r^2 = 0.751$, $P < 0.001$). The majority of children who initially lacked antibodies to isolates such as 3076, 3661, 1542 and 3940 that were extensively recognised at first cross-sectional survey, acquired antibodies to these isolates during the year (Fig 4.4A). On the other hand, fewer children acquired antibodies to isolates that were poorly recognised in the first survey.

The loss of antibodies to a given isolate showed a negative correlation ($r^2 = 0.605$, $P=0.004$) with the prevalence of antibodies to the isolate at the beginning of the year (Fig. 4.4B). There was no association between the chance of complete loss of antibodies and the initial levels the antibodies as measured by either flow cytometry or agglutination assays except for the case of response to isolate 1542 (OR - 0.215, 95% CI: 0.088 – 0.529, $P=0.001$)

Figure 4.4

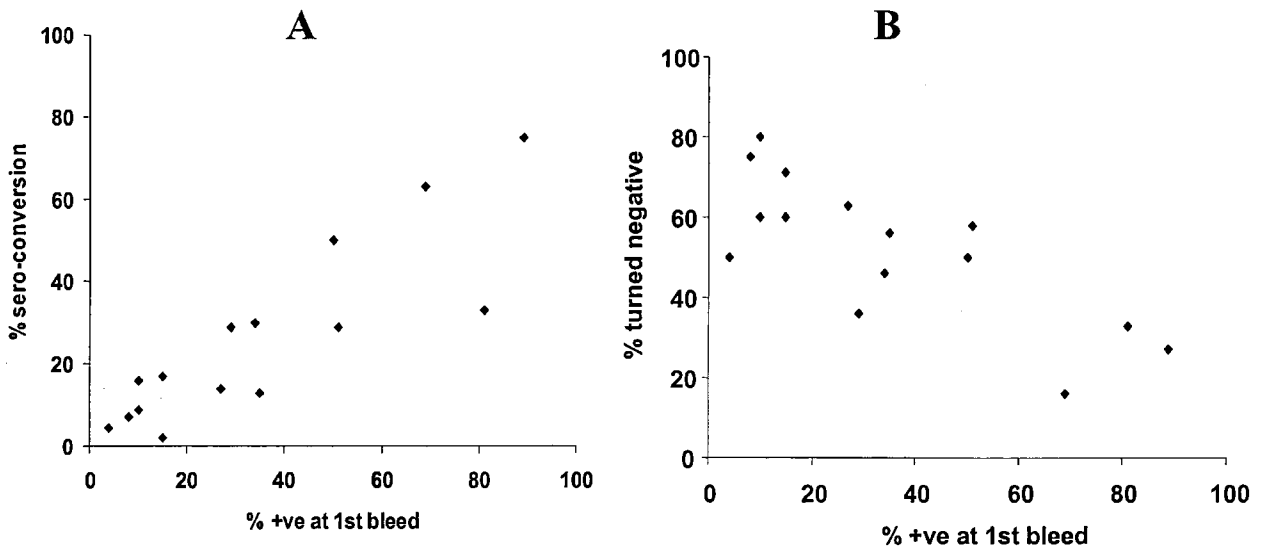

The percentage of children who sero-converted to each isolate during the year (A), and children who lost responses to the isolates (B) plotted against the prevalence of antibodies to each of the isolates at the beginning of the study year. Each point corresponds to an isolate. The plots combine from both the agglutination assays and flow cytometry

4.4 DISCUSSION

Antibodies to PIESA agglutinate schizont-infected erythrocytes in a variant-specific manner (Newbold, *et al.*, 1992) and are associated with protection against malaria episodes in some circumstances (Marsh, *et al.*, 1989; Bull, *et al.*, 1998; Giha, *et al.*, 2000; Doodoo, *et al.*, 2001). It has therefore been suggested that the acquisition of immunity to malaria might involve the accumulation of antibodies specific to the repertoire of locally circulating variants (Gupta and Day, 1994). That this might be the case is supported by the observation that the number of PIESA variants that individuals living in endemic areas can agglutinate increases with age (Bull, *et al.*, 1998). However, the dynamics of acquisition of anti-PIESA antibodies are unclear. Work done in the Sudan revealed that there is marked seasonal variation in individuals capacity to agglutinate a given parasite isolate and that both clinical and asymptomatic infections contribute to the stimulation of anti-PIESA responses (Giha, *et al.*, 1998). In Daraweesh, where the Sudanese study was done, transmission is unstable and seasonal, and the residents have poorly developed malaria immunity irrespective of age. It is not known how the acquisition of anti-PIESA antibodies varies under different transmission and immunological backgrounds. In this study, I examined the accumulation of anti-PIESA antibodies in Kilifi where transmission is higher and the classical age-immunity correlation is evident.

Plasma pairs obtained from children in two cross-sectional bleeds carried out a year apart were assayed for anti-PIESA antibodies against a panel of field and laboratory-adapted parasite isolates by agglutination and flow cytometry. The proportion of parasites positive for FITC surface staining rather than MFI was used as a proxy measure of antibody titres because this was better correlated with agglutination scores (see chapter 2).

The results confirmed previous observations from work done in Kilifi and elsewhere. First, both field and laboratory isolates display unique agglutination profiles when tested against a panel of sera confirming that they largely consisted of parasites expressing distinct PIESA variants (Newbold, et al., 1992). Second, the prevalence of antibodies to different isolates varies considerably. Some isolates such as 1542 3076, 3661 and 3940, were extensively recognised by the children while others (B7, and 4518) were only infrequently recognised. This is in line with the idea that there may exist common and rare PIESA variants (Bull, et al., 1999). Third, the prevalence of antibodies against PIESA variants increases with age (Forsyth, *et al.*, 1989; Iqbal, *et al.*, 1993; Bull, et al., 1998). Fourth, consistent with idea that increasing immunity with age might select for less commonly agglutinated PIESA variants (Bull, *et al.*, 2000), a strong, although not significant, inverse correlation ($r^2=0.742$) was observed between the frequency with which an isolate was agglutinated and the average age of the children who agglutinated it. However, this correlation was not evident in the flow cytometry arm of the study. Fifth, individuals exhibit seasonal variation in their anti-PIESA antibody repertoire (Giha, et al., 1998).

The laboratory cloned isolates A4, C10, and ITGIC15 from Brazil were not as widely recognised as the wild isolates. This may be because clones by nature contain a single or few variants while wild isolates many have multiple variants (S. Kyes, personal comm.) and therefore the prevalence of antibodies against a wild isolate is a sum of the prevalence of antibodies to it's constituent variants. Alternatively, the laboratory isolates may have been poorly represented in the local transmission system of Kilifi. It has been suggested that the ability of adults to agglutinate isolates from remote locations might be evidence for a variant-transcending immunity. I could not verify this as it was not possible to determine if the

children who acquired antibodies to these isolates actually encountered PIESA variants that are cross-reactive with the Brazilian isolates, or they were exhibiting variant-transcending responses. However, the fact that the children who recognise these isolates did not necessarily recognise all the other isolates suggests that if they had variant-transcending responses, these were not complete.

All children exhibited temporal variations in their PIESA antibodies repertoire. I assessed the effect of clinical episodes and age on the dynamics of these variations. Children who presented with at least one episode during the study year were designated cases while those who did not were designated controls. Both cases and controls showed similar level of the acquisition of novel specificities but the loss of specificity was slightly higher among the controls though not significantly. This suggests that although both symptomatic and asymptomatic infections contribute to the acquisition of novel specificities, clinical episodes may be more effective in maintaining detectable levels of anti-PIESA specificities. Similar observation were made by Giha *et al*, (2000) who reported that in Daraweesh, individuals who suffered a clinical episode during a follow-up period showed a significant increase in their post follow-up anti-PIESA responses repertoire while those who did not did not show any increase. Among the controls, acquisition of novel specificities was associated with a young age. This suggests that younger controls were acquiring new specificities through asymptomatic infections. Thus, despite not presenting with a clinical episode of malaria during the study period, the younger controls may still have been more susceptible to malaria infection than their older counterparts

When I considered the effect of age on the variation, I found that children below the age of 6 months primarily exhibited loss of specificities. This most likely reflects the decay of

passively acquired maternal antibodies. Despite having suffered at least one clinical episode of malaria, these children had lower levels of acquisition of novel specificities during the follow-up period than the rest of the children. One possibility is that the children failed to mount detectable response to variants encountered during the period. Alternatively, the older children might have had a wide repertoire of pre-existing, but undetectable specificities at the beginning of the year that were subsequently re-stimulated by infections with cross-reactive PIESA variants. If this were the case, such pre-existing repertoires might be expected to be limited in very young children.

Children who were above 7 years of age also displayed higher loss and lower acquisition of specificities compared to those between 6 and 83 months of age, although this differences were not significant. Since the majority of children in this age group did not suffer a clinical episode of malaria during the year, the observed higher level of loss of specificities is in line with the earlier proposal that clinical episodes may be important in maintaining detectable levels of anti-PIESA antibodies. The lower rate of acquisition of new specificities might be due to the higher prevalence of antibodies to the test variants among children in this age group at the beginning of the study.

I constructed checkerboards to help me explore the dynamics of anti-PIESA responses to each test isolates. The acquisition of agglutinating antibodies to isolates 4518 and 4386 occurred predominantly in children who were above 5 years of age. Isolate 4518 is interesting in that it came from a very young child (4 months) and yet was rarely recognised by the children in the study. Bull *et al* 1998 have described a similar isolate obtained from a 3 month old child and which was rarely agglutinated by children sera. They have suggested that the presence of maternal antibodies in the donor child could create an immune environment

similar to that in an adult and hence select for rare parasite variants that would normally be encountered at an older age. Thus, the acquisition antibodies to such variants may be associated with increasing immunity and age. Acquisition of antibodies to isolates 3026 on the other hand was associated with a young age. No obvious explanation could be found for this observation except perhaps that it came from a relatively young child though not as young as the donor of isolate 4518.

The proportion of children who sero-converted to a particular isolate during the year was highly correlated with the prevalence of antibodies to that isolate at the beginning of the year. In other words, the majority of children who initially did not recognise isolates such as 3076, 3661, 1542 and 3940 that were commonly recognised by other children, acquired antibodies to the isolates by the end of the year. This observation indicates that PIESA variants that were defined as common at the beginning of the year by agglutination assays and flow cytometry were indeed common in the local transmission system during the study year.

On the other hand, the proportion of children who lost antibodies to a given isolate was negatively correlated with the initial commonness of the isolate. This suggests that responses to the more common isolates are maintained by boosting through frequent contact with the isolates. Alternatively, it could be that the initial levels of antibodies to the commoner isolates were higher than those of antibodies to the less common isolates and hence persisted for a longer period. I did not titrate the test plasmas so I could not tell the levels of antibodies in them. However, I used results from cytometry and agglutination as proxy measures of antibody titres. Initial levels to all but one isolates did not influence the likelihood of the antibodies being absent by the end of the year. Thus, it is unlikely that the second explanation is applicable here. Finally, it is possible that the apparently large proportion of children

losing antibodies to the less commonly recognised isolates is simply due to the low number of children who initially recognised these isolates rather than lower initial levels of antibodies to this isolates.

The temporal variations in anti-PIESA specificities repertoire observed in this study suggest that anti-PIESA responses may be short-lived. Observations from these (chapter 3) and other studies elsewhere (Piper, *et al.*, 1999) suggest that antibody responses to PIESA may be dominated by IgG3 antibodies. If this were the case, then IgG3's short half-life would partly help explain the briefness of the responses observed here. In addition, isotype profiling of anti-PIESA responses among a separate group of 11 children from Kilifi (chapter 3) suggests that some children may fail to switch to IgG after initial IgM responses to PIESA. Such failure might reflect the induction of T-independent responses that are normally IgM dominated, short lived, and associated with poor induction of memory response. The observations that in malaria endemic areas, older individuals tend to have a wider repertoire of anti-PIESA specificities than children (Forsyth, *et al.*, 1989; Iqbal, *et al.*, 1993; Bull, *et al.*, 1998) suggest that despite these temporal variations, repeated infection nonetheless results in a net gain in the apparent size of an individual's anti-PIESA specificities repertoire.

In summary, this study has shown that children in Kilifi exhibit considerable temporal variation in their repertoire of anti-PIESA specificities, which suggests that the responses may be short-lived. It has also shown that both symptomatic and asymptomatic infections may be involved in the acquisition of anti-PIESA antibodies. The acquisition of antibodies to PIESA variants may be associated with age, consistent with the idea that the prevailing immune environment in a host might favour some PIESA variant over others. In addition, this study indicates that the commonness of a parasite as demonstrated by agglutination assays or

flow cytometry corresponds to the commonness of the isolate in the local transmission system. However, it is not clear over what duration this relationship holds. Finally, both agglutination assays and flow cytometry gave similar results. This is strong evidence that the two methods to a large extent are assessing the same responses.

CHAPTER 5

PROTECTION AGAINST CLINICAL EPISODES OF MALARIA BY VARIANT-SPECIFIC RESPONSES AGAINST PIESA

5.1 INTRODUCTION

Antibody responses to PIESA are variant-specific and there is evidence to suggest that they provide variant-specific protection against malaria. In view of this, the findings in a study in the Gambia (Marsh, *et al.*, 1989), the Sudan (Giha, *et al.*, 2000), and Ghana (Dodoo, *et al.*, 2001) that anti-PIESA antibodies to some variants but not others may be associated with protection against clinical episodes caused by apparently heterologous variants are difficult to explain. It is possible that such antibodies confer cross-protection against the variants causing clinical episodes. Alternatively, the variants in question might be a sufficiently common cause of disease in the study area so that possession of antibodies against them is associated with reduced incidence of disease. However, possession of these responses might simply reflect generally better anti-malaria immunity. We carried out a study to see if anti-PIESA responses to some local field and laboratory-cloned isolates were associated with protection against clinical episodes of malaria among children in Kilifi. We attempted to address the question of how such protection might be mediated by checking if protection was correlated with the relative frequency of a PIESA variant in the local transmission system during the study period

5.2 STUDY DESIGN

The relationship between the possession of antibodies against various PIESA variants and the risk of subsequently suffering a clinical episode of malaria was assessed in two sets of data. The first set of data came from 256 children of up to 10 years of age. These were all the children who participated in the cross-sectional survey at the beginning of the longitudinal study. The plasma samples obtained at the survey were assayed by flow cytometry for anti-PIESA antibodies against a panel of laboratory (A4 and ITGIC15) and 6 field isolates and the levels of response to each isolate assessed for association with protection against clinical episodes during the follow-up period. Details of the field isolate donors are given in table 5.2. The second set of data came from the study on the dynamics of antibody responses to PIESA described earlier on (Chapter 4). The children involved in this earlier study were a subset of the 256 mentioned earlier on in this paragraph. In this study, the children's anti-PIESA responses to a panel of 15 parasite isolates (Table 4.2A & B) at the beginning and the end of a one-year follow-up period were assessed by either agglutination (48 children) or flow cytometry (71 children). The rate of sero-conversion to the isolates during the study period was taken as a reflection of how frequently the isolate was encountered during the study period. These data was therefore used to explore the relationship between protection against clinical episodes by anti-PIESA responses and the relative frequency with which the test isolates were encountered in Kilifi.

Data analysis

For the purpose of this study, a clinical episode of malaria was defined as fever (axillary temperature = $>37.5^{\circ}\text{C}$) in the presence of 5000 parasites per micro litre of blood. For the responses that were assayed by agglutination, the degree of agglutination scored on a semi-quantitative scale of increasing intensity was taken as a proxy measure of the agglutinating

antibody titre. For flow cytometry, the proportion of cells positive for FITC staining was taken as proxy measure of antibody titre. Although the field isolates might have consisted of more than one PIESA variant, it could not have been possible to separate the constituent variants and therefore the isolate was treated as a single variant. Since the relationship between functionality and titre might differ among antibodies directed against different PIESA variants (i.e. high titres of antibodies against one variant might have effects equal to those of lower titres of antibodies against another variant), the titres were standardised by expressing each child's response against each of the isolates as a ratio of the highest response observed for that particular isolate. The relationship between titres of antibodies to each isolate on the risk of a child suffering a clinical episode of malaria during the two-year study period was assessed by logistic regression after correcting for age. Since responses to some of the isolates were significantly correlated, calculation of the protective effect of responses to each isolate was adjusted to take account of any other responses that were also associated with protection.

5.3 RESULTS

General Observations (Table 5.1 & Fig. 5.1)

The children were categorised into seven one-year age groups ranging from 0 to 7 years and above. 106 (41%) children had no episode during the two years while 63 (25%) children presented with one episode and 87 (34%) had two or more episodes. The highest number of episodes in any child in the two years was 8. Table 5.1 is a summary of the mean period prevalence of episodes per child within each age group in the two years of the study. The highest number of episodes per child was observed in the 5 years group. Figure 5.1 shows the distribution of episodes among the age groups. The proportion of children who had at least

one episode in the first year was similar among the children below age of 7 years lying between 40-60% with a peak in the 3-years group. However, a significant drop to 17% was observed at the age of 7 years and above ($X^2 = 12.11, P=0.0005$).

Table 5.1

Age (mnts)	0-11	12-23	24-35	36-47	48-59	60-71	72-83	>84
n	13	56	25	32	37	30	27	36
Year 1	0.62	0.89	0.76	0.76	0.76	0.97	0.52	0.17
(sd)	(0.87)	(1.44)	(0.83)	(0.96)	(0.83)	(1.32)	(0.70)	(0.38)
Year 2		0.92	0.70	0.32	0.60	0.70	0.50	0.30
(sd)		(1.15)	(0.90)	(0.69)	(0.98)	(1.13)	(0.94)	(0.67)

The average number of episodes per child in the two years follow-up up. Sd – standard deviation

Figure 5.1

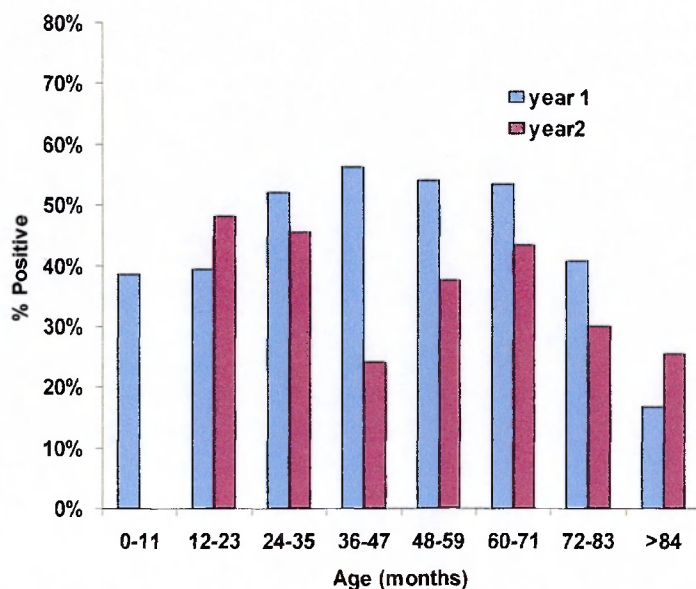

Percentage of children in each of the age category who presented with at least one episode during the first and second year of the study. The 0-11 month category was absent in the second year of the study.

The prevalence of antibodies to the test isolates. (Table 5.2 & Fig. 5.2)

Only 4% of the children had antibodies to Isolate B7 while 50% of the children had antibodies to isolate 3030. The other isolates were recognised by between 20-30% of the children (Table 5.2). The number of isolates an individual recognised was significantly correlated with age ($r^2 = 0.129$, $P > 0.001$, fig.5.2) but was not associated with protection against clinical episodes. Some of the children below the age of 6 months had high antibody titres and recognised a large number of isolates.

Table 5.2

Isolate	B7	1776	4451	4518	ITGIC15	1509	A4	3030
Clinical history of donor	UC.	Severe	Severe	Severe		UC.		Severe
Age of donor (months)	48	6	36	38		32		36
Antibody prevalence	3%	19%	20%	21%	23%	26%	30%	50%

The prevalence of anti-PIESA antibodies to the test isolates. UC. – uncomplicated malaria among 256 children

Figure 5.2

The number of isolates that a child recognised plotted against the child's age. The vertical bar corresponds to 6 months. The diagonal line is the regression line Each point represents data from an individual child (n=256).

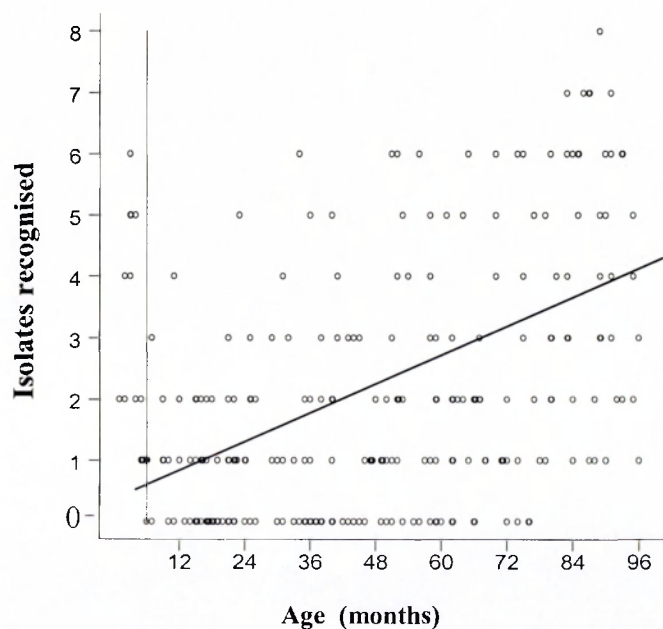

Relationship between specific anti-PIESA responses and age. (Fig. 5.3)

The titres of anti-PIESA responses to each of the test isolates were significantly ($R < 0.001$) associated with age except for response to isolates 4518.

Figure 5.3

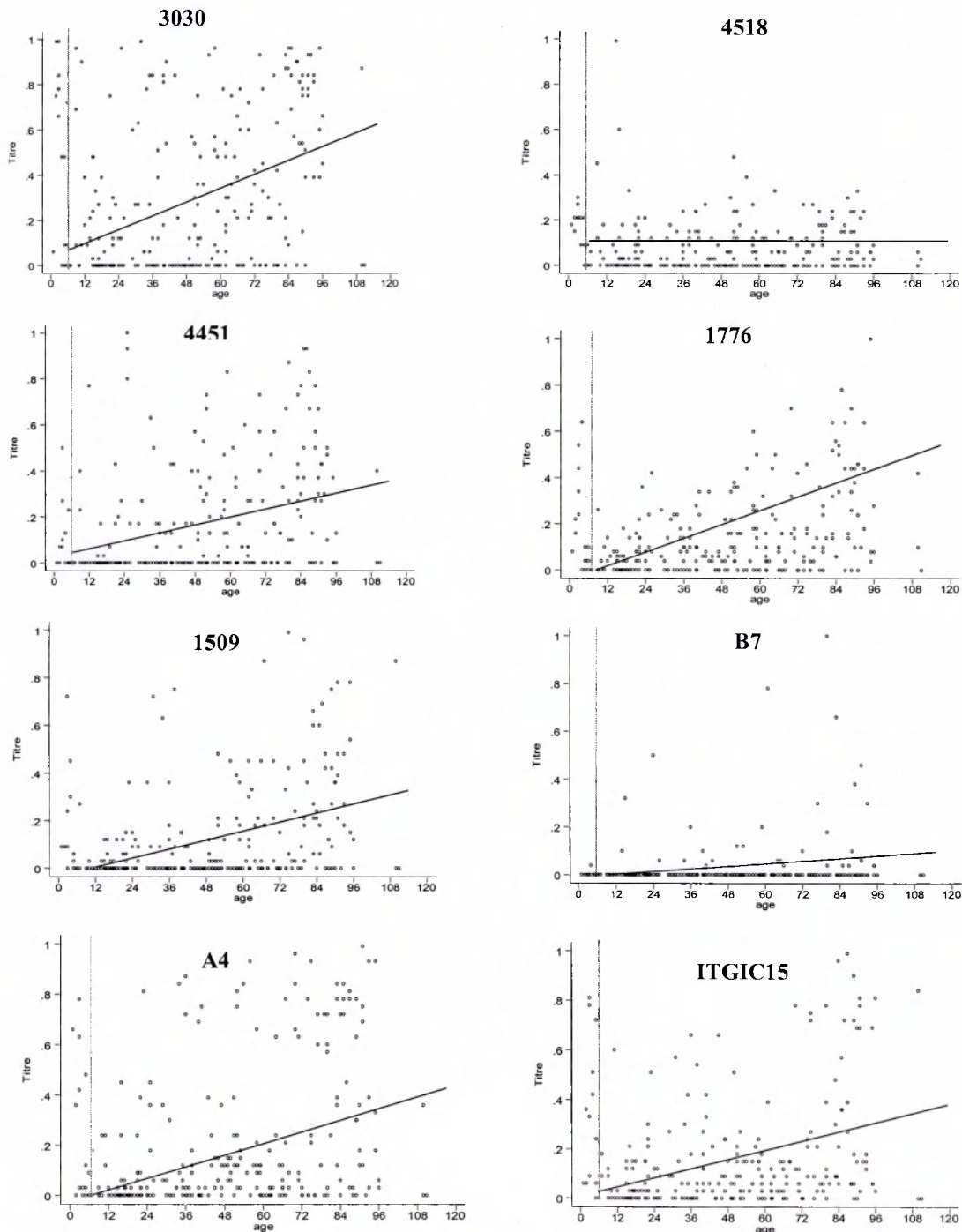

Individual antibody responses to 8 isolates plotted against age in months of the plasma donors, titre is a given as a ratio of the highest response to each isolate. The faint vertical line corresponds to 6 months (n=256). A regression line is included in each plot.

Correlation between titres of specific antibodies to each isolate and the total number of isolates that a child recognised.

Table 5.3 below gives the coefficients of correlation (r^2) between specific responses to each isolate and the total number of isolates against which a child had antibodies.

Table 5.3 A

Isolate	3030	1776	A4	4451	1509	ITGIC15	4518	B7
Corr Coeff.	0.740	0.661	0.561	0.538	0.536	0.506	0.392	0.258

B

Isolate	3893	1542	3940	3944	1541	A4
Corr. Coeff.	0.800	0.783	0.772	0.739	0.603	0.436

The correlation between responses to each isolate and the number of test isolates to which a child had antibodies. A – dataset 1, n=256. B - Data from study on dynamics of anti-PIESA responses (n=71)

Relationship between anti-PIESA antibodies and risk of clinical episodes.

(Table 5.4A)

Anti-PIESA responses to a panel of isolates by 256 children were analysed for association with protection against clinical episodes of malaria in a two-year period. Because responses to all the isolates tested except isolate 4518 were associated with age which in turn was associated with reduced period prevalence of clinical episodes, a logistic regression model with a correction for age was used. Possession of antibodies to isolate 1776 was significantly

associated with protection against clinical episodes in the first year of follow-up and when the analysis covered both years of follow-up but not when the second year was considered independently. Possession of antibodies to A4, ITGIC15, and isolate 3030 was associated with protection in the second year of follow-up. However, only the possession of antibodies to isolate 1776 remained significantly associated with protection even after adjusting for the other apparently protective responses.

The relationship between protection against clinical episodes by anti-PIESA responses and the relative frequency of isolates in the local transmission system. (Table 5.4B)

Using data from the study on the dynamics of accumulation of anti-PIESA antibodies (chapter 4), we examined whether protective responses could be demonstrated in the smaller group of children (n=71) tested against a different set of isolates and if there was any relationship between the protective efficacy of the responses and the relative frequency of the isolate in the local transmission system as determined by the proportion of children who sero-converted to the isolate during the study period. Responses to three isolates (1542, 3893 and 3940) at the beginning of the study period were significantly associated with protection against episodes in the two years even after allowing for age. After adjusting for responses to the other two isolates, only responses to isolate 3983 retained a significant association with protection .

Table 5.4A

ISOLATE	Corrected for response to the other isolates					
	Year 1 OR (95% CI)	P	Year2 OR (95% CI)	P	Year 1 + 2 OR (95% CI)	P
1776	0.157 (0.024 – 1.000)	0.050	0.172 (0.0257 – 1.161)	0.072	0.096 (0.017 – 0.550)	0.009
A4	0.536 (0.191 – 1.508)	0.237	0.306(0.097 – 0.958)	0.042	0.354 (0.131 – 0.956)	0.040
ITGIC15	0.682 (0.186 – 2.508)	0.565	0.185 (0.040 – 0.854)	0.031	0.38590.112 – 1.323)	0.130
3030	1.075 (0.449 – 2.573)	0.870	0.379(0.147 – 0.977)	0.045	0.917(0.386 – 2.177)	0.844
0.027					0.102 (0.014 – 0.771)	0.027
0.185					0.488 (0.169 – 1.411)	0.185
0.063					0.215 (0.043 – 1.084)	0.063
0.139					0.457 (0.162 – 1.290)	0.139

ISOLATE	Corrected for response to the other isolates						
	Sero- conversion	Year 1 OR (95% CI)	P	Year2 OR (95% CI)	P	Year 1+2 OR (95% CI)	P
3893	28.5 %	0.107 (0.009 – 1.355)	0.085	0.116 (0.0138 – 0.953)	0.047	0.009 (0.003 – 0.246)	0.005
1542	63.6 %	0.079 (0.006 – 1.066)	0.056	0.265 (0.034 – 2.066)	0.205	0.023 (0.001 – 0.596)	0.023
3940	75.0 %	0.231 (0.028 – 1.925)	0.176	0.611(0.014 – 0.970)	0.591	0.041 (0.003 – 0.629)	0.022
0.050						0.002 (0.001 – 1.000)	0.050
0.796						0.501 (0.002 – 93.322)	0.796
0.462						0.256 (0.007 – 9.689)	0.462

A. The odds ratio of a child suffering a clinical episode of malaria during the follow-up if they had antibodies against various isolates at the beginning of the follow-up (n=256) B. The relationship between the rate of sero-conversion to an isolate and the protective efficacy of responses against the isolate (n=71). Significant OR are highlighted in a bold font. ‡ Correction for other protective responses within the column where protection by response to the isolate in question was observed. For both tables antibody levels were assayed by flow cytometry

5.4 DISCUSSION

I investigated the relationship between anti-PIESA antibodies and protection against clinical episodes of malaria in children. Clinical episodes in 256 children were monitored for two years through active and passive case detection. A case definition of 5000 parasites per microlitre of blood and an axillary temperature of 37.5⁰C and above was used. This definition has a sensitivity and specificity of over 90% in Kilifi (T. Mwangi, personal communication) and other areas of similar endemicity (Schellenberg, *et al.*, 1994). 150 (59%) of the children had at least one clinical episode during the follow-up period that extended across two minor (November-December) and two major (May – July) transmission seasons. The period prevalence of episodes was roughly the same among children below 6 years of age although a peak was observed in the 3-4 years group. At 7 years of age, a significant drop in the period prevalence was observed. This distinct drop suggests that there may be a threshold effect in the development of immunity against clinical malaria.

The average number of isolates against which each child had antibodies increased with age as did the levels of antibodies against all the isolates except among the youngest children who had high titres probably reflecting passively acquired maternal responses. However, neither of these parameters was predictive of protection against clinical episodes of malaria. Although responses to isolates A4, ITGIC15, 3030, and 1776 appeared to be associated with protection against clinical episodes during the follow-up, only response to isolate 1776 were independently associated with protection in the two year period even after adjusting for age and the interaction with responses to the other isolates.

An advantage of this study is that length of follow-up extended over four transmission seasons. As a result, we were able to detect protective effects that were otherwise apparent when each of the two years was considered individually. Since some children with low titres of the protective antibodies might still go through a transmission season without suffering a clinical episode by chance, it is possible that considering clinical experience over a longer period allows better distinction of different immune status.

The finding that anti-PIESA response against some but not other isolates are predictive of protection against malaria episodes is consistent with report from studies done elsewhere. Marsh *et al* (1989) found that titres of agglutinating antibodies against a single parasite isolate were predictive of reduced risk of clinical episode of malaria in Gambian children. Two other studies using flow cytometry have also reported the association of protection against clinical episodes with possession of antibodies to particular isolates but not others. In the first study carried out in the Sudan, anti-PIESA responses to 9 isolates were examined, only antibodies against a Ghanaian parasite isolate were associated with protection against malaria (Giha, *et al.*, 2000) while in the second study in Ghana, responses to the surface of four isolates were analysed, only antibody responses to a Sudanese and a Ghanaian isolate were associated with protection (Dodoo, *et al.*, 2001).

Two possible explanations for these observations are: 1) the particular isolates that are target for protective response, were a major cause of morbidity among the study subjects. Thus, the possession of antibodies against the isolates at the onset of the study would protect against clinical episodes during the study; 2) the possession of these particular specificities was a marker of a wider repertoire of anti-PIESA responses and /or responses to other antigens. The first explanation might be plausible in the Sudanese study as all the

cases initially lacked the antibodies to the Ghanaian isolate that was associated with protective responses but over half of them had acquired them by the end of transmission season. This suggests that they had been infected by isolates bearing PIESA similar to those on the Ghanaian isolate during the season. Among this Sudanese population most infections tend to be symptomatic due to their low immunity. Thus, if the Ghanaian isolate was an important cause of morbidity during the study, pre-season ability to resist infection by the isolate would have prevented one from suffering clinical episode

We used data from a study on the dynamics of anti-PIESA responses described in chapter 4 to examine whether the first explanation also applied to our study. From this data we had previously calculated the relative frequency with which the isolates were encountered in the local transmission system. We therefore hypothesised that if the most frequently encountered isolates were also the main cause of morbidity during the study, responses directed against them would be associated with protection from clinical episodes. This appears to be the case on a univariate analysis, as possession of anti-PIESA responses to the two most frequently encountered isolates (3940 and 1542) was associated with protection. However, the association was lost when a correction for responses to a third less common isolate (3893) that were also associated with protection was done. Only responses to the third isolate remained protective even after allowing for age and responses to the other isolates. Thus, the relative frequency of an isolate does not explain the association between anti-PIESA antibodies to the isolate and protection against clinical disease.

Since responses to both isolate 1776 and 3893 had the highest correlation with the total number of isolates that an individual recognized, it might suggest that they were markers

of the size of anti-PIESA specificities repertoire in an individual. Thus, by having a wider repertoire of anti-PIESA responses, individuals who possessed responses to these two isolates at the beginning of the follow-up were more likely to be protected against any of the isolates that were circulating in Kilifi during the study period. However, the number of isolates a child recognised at the beginning of the study was not itself associated with protection against subsequent clinical episodes and hence this explanation may not be sufficient.

This study confirms the association of variant-specific response against certain PIEASA variants with protection against clinical episodes against malaria. However, I did not manage to resolve the question of how this apparently heterologous protection is mediated. Further work is required to try and establish how isolates that appear to be targets for protective anti-PIESA response during a surveillance period are related to the isolates causing morbidity during the same period. Mixed agglutination and genetic techniques could be used for this.

CHAPTER 6

PROTECTION AGAINST CLINICAL MALARIA BY ANTIBODIES AGAINST SCHIZONT ANTIGENS

6.1 INTRODUCTION

In the studies described in the previous chapters, we set up a longitudinal framework to enable us examine in detail immune response to the surface of malaria infected red cells. The same framework is clearly appropriate for examining responses to other malaria antigens. In chapter 1, I have reviewed the information on some of the merozoite antigens that have been identified as potentially important targets for protective immunity against malaria. Many of these antigens were initially identified through the screening of antigens on western blots, by immune-precipitation or the screening of expression libraries with “immune” sera. However, in these studies, the immune sera were often obtained from experimentally immunized animal or from people whose disease experience was poorly documented. Thus, the definition of “immune” sera was usually imprecise. We therefore decide to re-examine the issue of whether we could identify other schizont antigens that may be targets for protective immune responses if we incorporate more detailed information on disease experience obtained from the longitudinal study in the screening process.

6.2 STUDY DESIGN

Plasma samples from the 127 individuals, 26 of who were older than 10 years, who formed part of a two-year active malaria surveillance, were assayed for antibodies to schizont antigens of a laboratory isolate A4-BC6 separated by SDS PAGE. These individuals were

selected because they gave a second blood sample at the end of the first follow-up year. The plasmas from the first survey were first assayed individually for IgG antibodies, then the individuals were categorised into three groups in relation to their disease experience during the 1st year of follow-up. Those who did not suffer any acute episode during the year, those who had only one episode and those who had two or more episodes were designated “immune”, “semi-immune”, and “non-immune” respectively. Plasma from each category was then pooled in order to look for common response. As the number of children in each category differed, the pools were diluted using plasma from Europeans with no previous exposure to malaria so that final dilution of the constituent plasmas were the same as the dilution in the pool with the largest number of children. A second set of pools was also prepared with the corresponding second survey plasmas. The pools were then assayed for IgM, IgG, and IgG subclasses against the blotted proteins.

6.3 MATERIALS AND METHODS

Parasite culture and antigen extraction

A4-BC6 clone was used as the source for schizont antigens. This clone was selected by panning infected red cells on a monoclonal antibody BC6 that is specific for A4 var gene products (Fig 2.2). The parasites were cultured according to standard methods (Trager and Jensen, 1976) in group O positive red cells from malaria non-immune European donors until the majority of parasites were late trophozoites or schizonts. Infected erythrocytes were obtained by floating on Plasmagel. The separated infected cells were washed at least thrice in phosphate buffered saline (PBS) centrifuging between the washes to remove the buffer. After the final wash, the pellet was diluted 1:4 with PBS supplemented with protease inhibitors (2mM TLCK, 1mM TPCK, 1mM PMSF, 10µg/ml leupatin, 10µg/ml antipain, 10µg/ml

aprotinin and 10 μ g/ml chymostatin) and lysed with an equal volume of sample buffer (100mM Tris, 2% SDS, 10% glycerol, and 10% β -mercaptoethanol). DNA interferes the migration of proteins through the gel and was therefore removed from the sample by shredding through repeated passing of the sample through a narrow bore needle followed by centrifugation at 10,000g for 5 minutes. The supernatant was obtained, boiled for five minutes, spun again and the pellet discarded. Un-infected red cell proteins were also extracted in the same manner and used as controls on the blot to detect antibodies that might be directed against components of the red cell.

Preparation of polyacrylamide gels (Table 6.1 A & B)

The gels were run under reducing conditions. The running gel was prepared by mixing the appropriate volumes of buffers depending on the required strength and volume of gel in a 50ml centrifuge tube. The gel was then poured into the casting cell, overlaid with stacking gel that was in turn overlaid with methanol to prevent drying. A comb was placed into the stacking gel and the gel left to set. Once the gel had polymerised, the comb was removed and the wells washed at least thrice with double distilled water. The whole gel preparation was then transferred into an electrophoresis tank and running buffer (3g Tris, 14.4g glycine, 10ml 10% SDS, ddH₂O to 1000 ml) added. A few grains of bromo-phenol blue were added to the upper buffer to help track the protein migration through the gel. Table 6.1A is a summary of the buffers used in the preparation of the polyacrylamide gel while Table 6.1B gives the composition of the gels at 5% and 10% strength.

Table 6.1A

Solution A	Solution B	Solution C
48ml 1M HCL	48ml 1M HCL	30% (w/v) Acrylamide/0.8% (w/v) bisacrylamide
36.3g Tris	5.98g Tris	
0.23ml TEMED	0.48ml TEMED	
ddH ₂ O to 100ml	ddH ₂ O to 100ml	

B

	5% Running Gel	10% Running	Stacking Gel
Solution A	2.5 ml	2.5 ml	
Solution B			0.95 ml
Solution C	1.7 ml	3.3 ml	1.25 ml
10% (w/v) SDS	0.1 ml	0.1 ml	0.075 ml
10 (w/v) AMPS	0.1 ml	0.1 ml	0.075 ml
ddH ₂ O	5.7 ml	4.0 ml	5.0 ml

A) Buffers used to cast polyacrylamide gels for SDS-PAGE. B) Composition of gels for SDS-Page. SDS –sodium dodecyl sulphate, AMPS – ammonium persulphate, ddH₂O – double distilled water

Electrophoresis.

6ul of the protein suspension was loaded in each well on the gel and separated at 200 volts until the tracking dye migrated through the gel. Parasite proteins were separated on a 10% gel while un-infected red cell proteins were run at 5%. High precision molecular weight markers were electrophoresed along with the schizont extract as a guide to the protein molecular weights.

Electroblotting

After the end of the electrophoresis, the gel was transferred onto an electroblotting cassette and place into an electroblotting tank filled with ice-cold electroblot buffer (20% methanol, 3.03 Tris and 14.41 glycine made up to one litre with ddH₂O). In addition, ice packs were

place on both sides of the cassette and the buffer agitated continuously by a magnetic stirrer to prevent the gel from heating up during the transfer. Proteins were transferred for at least 1 hour at 100 volts onto a nitrocellulose membrane .

Probing the blots with antibodies

The membrane were blocked with 0.05% Tween, 0.5% BSA, 5% fat-free milk in CMF-PBS (0.13 M NaCl, 2 mM KCl, 8 mM Na₂HPO₄, 1.5 mM KH₂PO₄), for at least one hour. After washing twice in milk-free blocking buffer, the membranes were cut into strips, and each strip placed in a test tube containing test plasma diluted in milk-free blocking buffer. The tubes were placed on a shaker and agitated for an hour, after which four ten-minute washes in blocking buffer were done. The strips were then probed for half an hour with secondary antibodies conjugated to Horse Radish Peroxidase (HRP) diluted in blocking buffer. Individual plasma was assayed at a 1:250 dilution. Pools were assayed at 1: 600, 1:1200, 1:2400, and 1:4800 dilutions for IgG and at dilutions of 1:250, 1:500, 1:1000, and 1:2000 for IgG subclasses 1 and 3 while IgM, IgG2, and IgG4 were assessed at 1:50 and 1:200 dilutions. Malaria non-exposed European plasma was used as the negative control

After a further four ten-minutes washes, the strips were treated with Enhanced Chemiluminescence reagents as per the manufacturer's instructions. This involved mixing equal volumes of solutions A and B (pre-prepared by the manufacturer) and flooding the strips for about half a minute before drip drying the strips. The strips were then exposed to a photographic film in a dark room and the film developed. The highest dilution at which a positive reaction with a protein band was observed was taken as the titre for antibodies against that band

Data analysis

A template of the protein bands separation was obtained by staining a gel after electrophoresis with 0.05% (w/v) coomassie blue in 20% (v/v) methanol / 10% (v/v) glacial acetic acid for five minutes, then destaining for 30 minutes in the same buffer without the dye. The gel was then dried onto a blotting paper. Molecular weight of each band was estimated from a plot of migration distance of the standard molecular weight markers against the log of the markers' molecular weight.

The blots were examined visually and the protein bands with which each plasma reacted recorded by apparent molecular weight. Samples that reacted with less than four bands were re-assayed to rule out the possibility that this was due to technical flaws. The relationship between the numbers of episodes an individual suffered and the possession of antibody to the protein bands was assessed by a logistic regression with a correction for age. For the pooled plasmas, the blots were examined visually and the highest dilution at which a positive reaction with each band could be detected taken as the titre of antibodies against the particular band. The data was stored in Excel (Microsoft Corporation) and analysed in STATA ver. 6

6.4 RESULTS

Antibody responses to un-infected red cell proteins. (Fig 6.1)

Reactivity against red cell components was established by electrophoresing and blotting un-infected cells proteins extracted by the same protocol as the infected cells. Two major bands stained strongly on the gel; a 220-250 kDa doublet and a band that migrated between 66-70 kDa. When the blot was probed with pooled plasma, a weak reaction with the three bands and additional bands at about 100-110 kDa was observed. With washing that was more rigorous

and a longer period of incubation of the blot membrane in blocking buffer, the background staining was reduced to minimal. The more rigorous washing process was therefore adapted for the actual study.

Figure 6.1

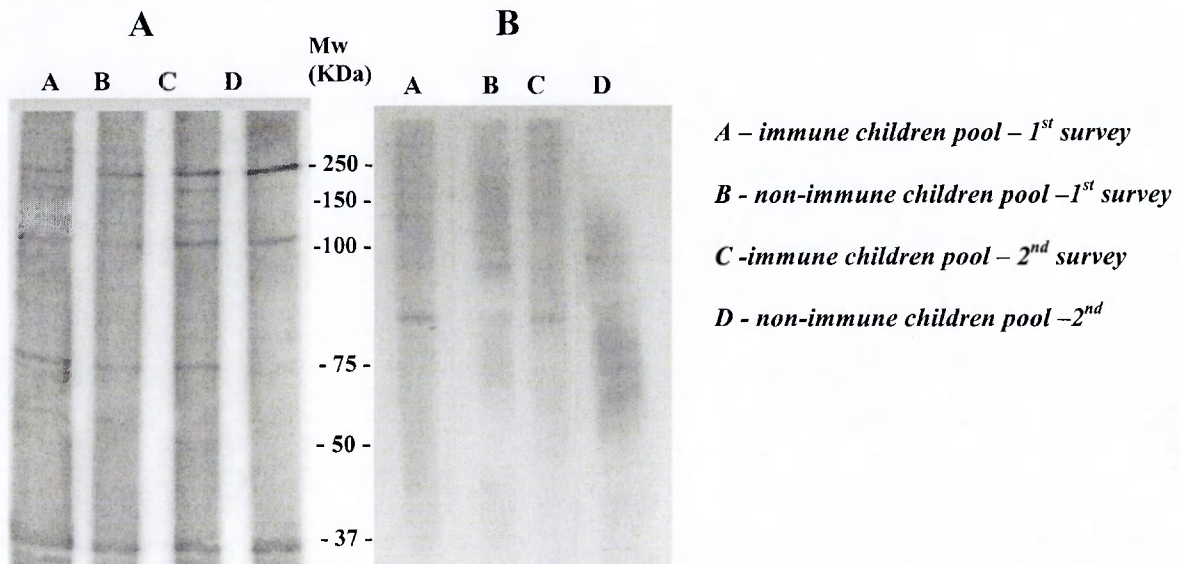

A) IgG responses to un-infected red blood cells proteins separated on a 5% gel. The membrane was subjected to either 3 washes of 10 minutes each in milk-free blotting buffer prior to probing with the secondary antibody, or B) 4 washes of 10 minutes each

Individual reactivity to malaria antigens. (Fig 6.2)

Plasma from the first survey was first assayed individually for IgG at a dilution of 1:250. While non-immune European plasmas did not react with any of the protein bands, plasma from most of the study subjects reacted with one or more bands. The number of bands that each individual recognised increased with age ($r^2=0.226$, $P=0.010$) but was not associated with protection against clinical episodes of malaria. However, it was observed that plasma from some older (>84 months), apparently immune (as judged by the lack of clinical episodes during the follow-up) individuals reacted with only a few bands. Individuals who were parasitaemic at the time of the first survey showed a higher, though not significant, tendency

to recognise a larger number of bands (OR=1.510, CI: 0.397-5.740, P= 0.545). Figure 6.2 is a sample of some of the individuals who had strong responses to many of the bands contrasted with individuals who had poor responses.

Figure 6.2

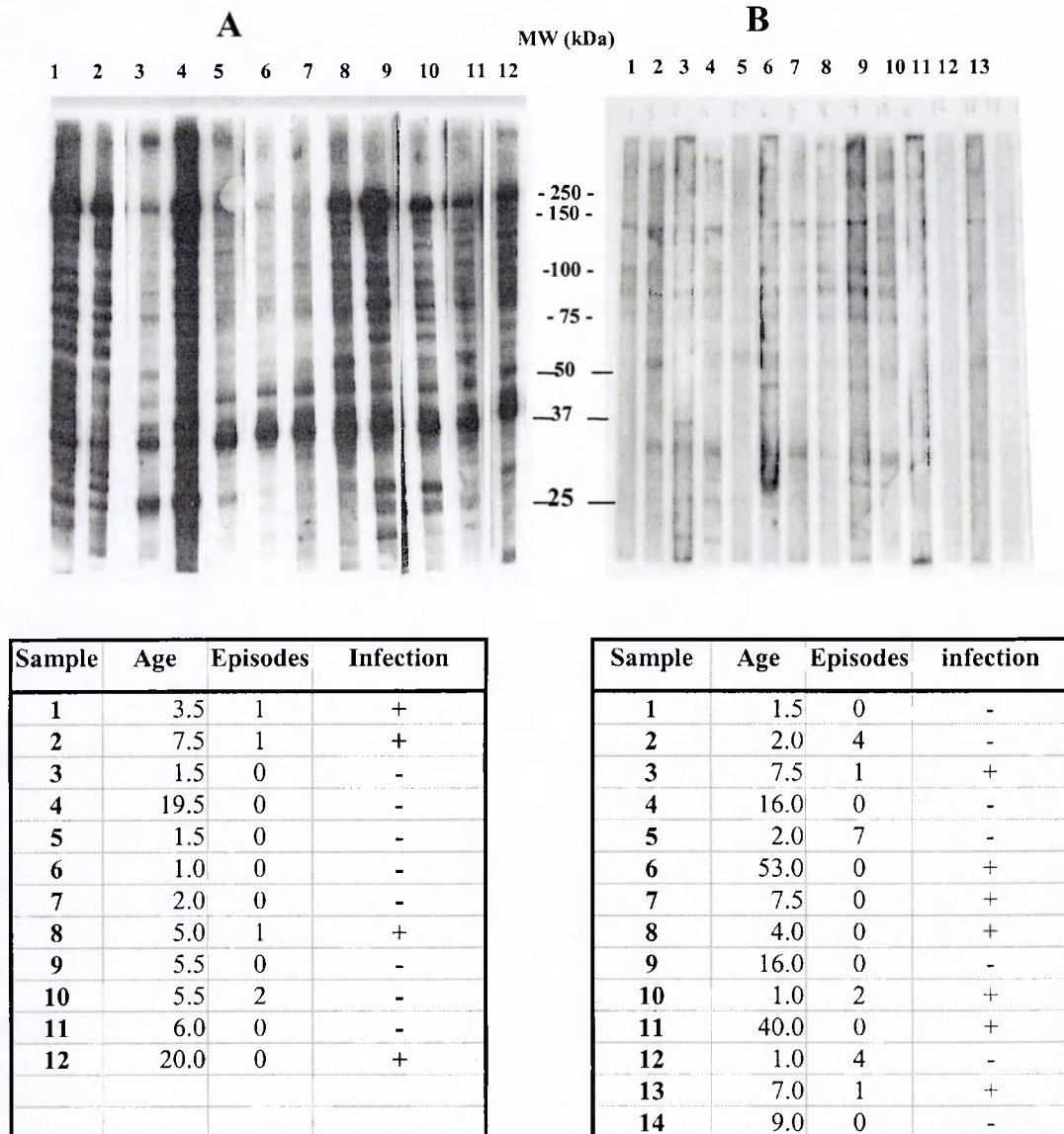

A sample of blots of individuals who had good responses (A) contrasted with individuals who reacted poorly with most of the antigens (B). The tables shows the age, disease experience, and parasitological status during the survey of the plasma donors..

Prevalence of antibodies against each protein band (Fig 6.3A)

14 protein bands ranging from 250 kDa to about 30kDa were recognised on the Coomassie blue-stained template and assigned a number based on their relative molecular. The prevalence of antibodies to each band varied considerably with some being recognised by majority of the plasma samples while others were only recognised by a few individuals. The majority of individuals recognised band(s) in the 200-250 kDa region. However, proteins above 200 kDa were poorly resolved and blotted. Therefore it is difficult to make any inferences on antibody responses directed against them. The prevalence of antibody response to the other bands that were frequently recognised were as follows: 110 kDa - 63%; 48kDa - 61%; 36 kDa - 60%; 88 kDa - 50%; 125kDa - 48%

Correlation between age, episodes, and reactivity to various antigens. (Fig. 6.3B)

The prevalence of antibodies generally increased with increasing immunity and age although the association with age was significant ($P < 0.05$) only in the case of response to the 250kDa, 76 kDa, 43kDa, 37kDa, and 33 kDa bands. Since the period prevalence of episodes also decreased with age (younger than 8 years Vs 8 years or older, $X^2 = 32.6$, $P > 0.000$), we corrected for age when assessing the protective effect of responses to each band. Only responses to the 192 kDa band were associated with protection against clinical episodes, although not significantly when age was taken into account (OR = 0.252 CI: 0.061-1.047, $P = 0.058$)

Figure 6.3

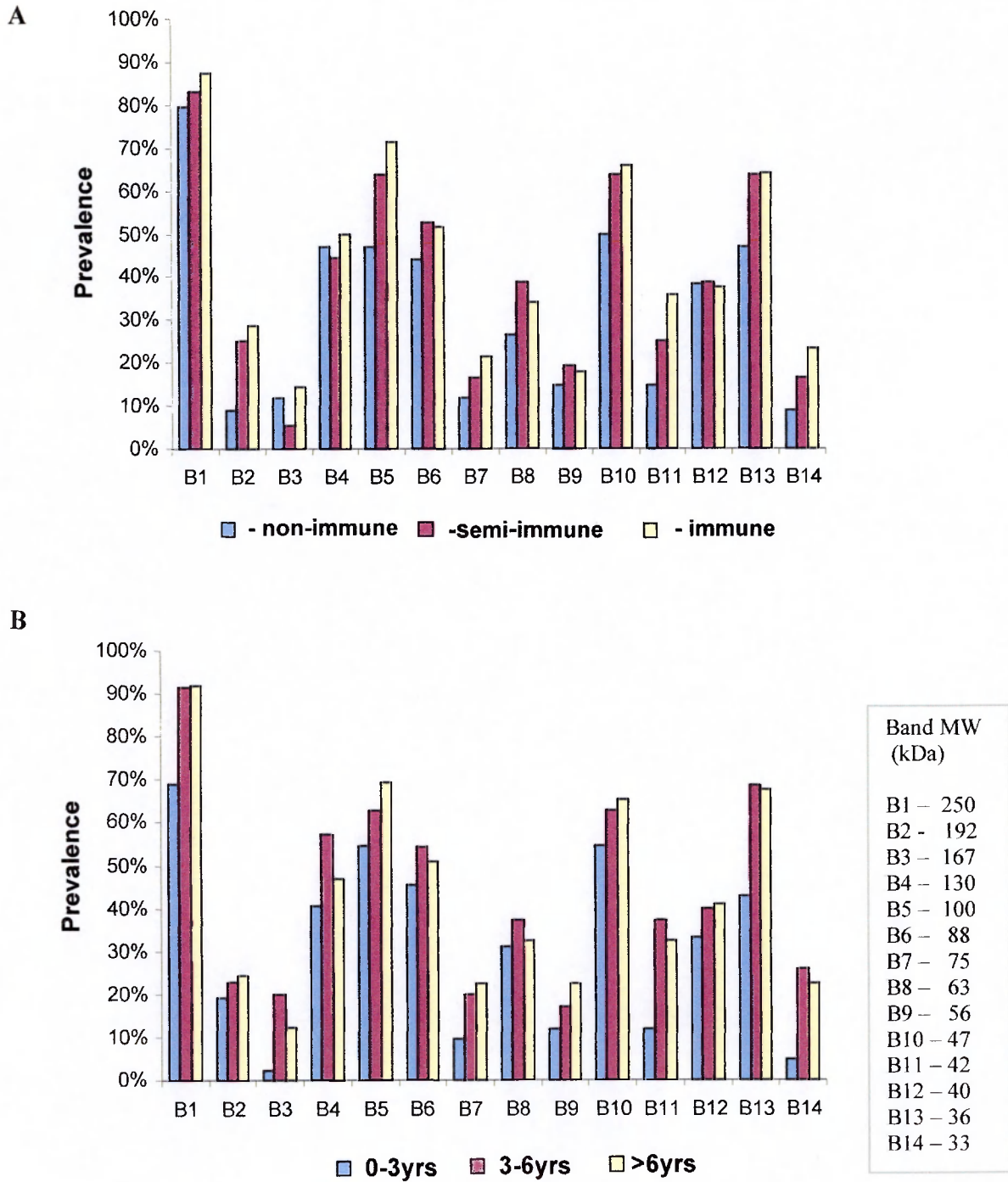

A) The prevalence of antibodies to various schizont antigens among the study subjects stratified by future disease experience and B) stratified by age. On the right are the molecular weights of the numbered bands.

Correlation between IgG levels in pooled plasma and immune status (Fig 6.4)

Children were categorised according to their disease experience in the first year of follow-up and plasmas from each category pooled. The relative amount of antibodies to each band in each pool was assessed by blotting with dilutions of the pool. All the six pools had high IgG titres (1:2400) against all the 14 bands. The first survey pool from immune children had higher titres responses to the 36 kDa band than the non-immune pool while the second survey immune pool had twice as high titres (4800 Vs. 2400 dilution factor) of antibodies to the 100, 88, 42, 40, 36, and 33 kDa bands as the corresponding non-immune pool.

Figure 6. 4

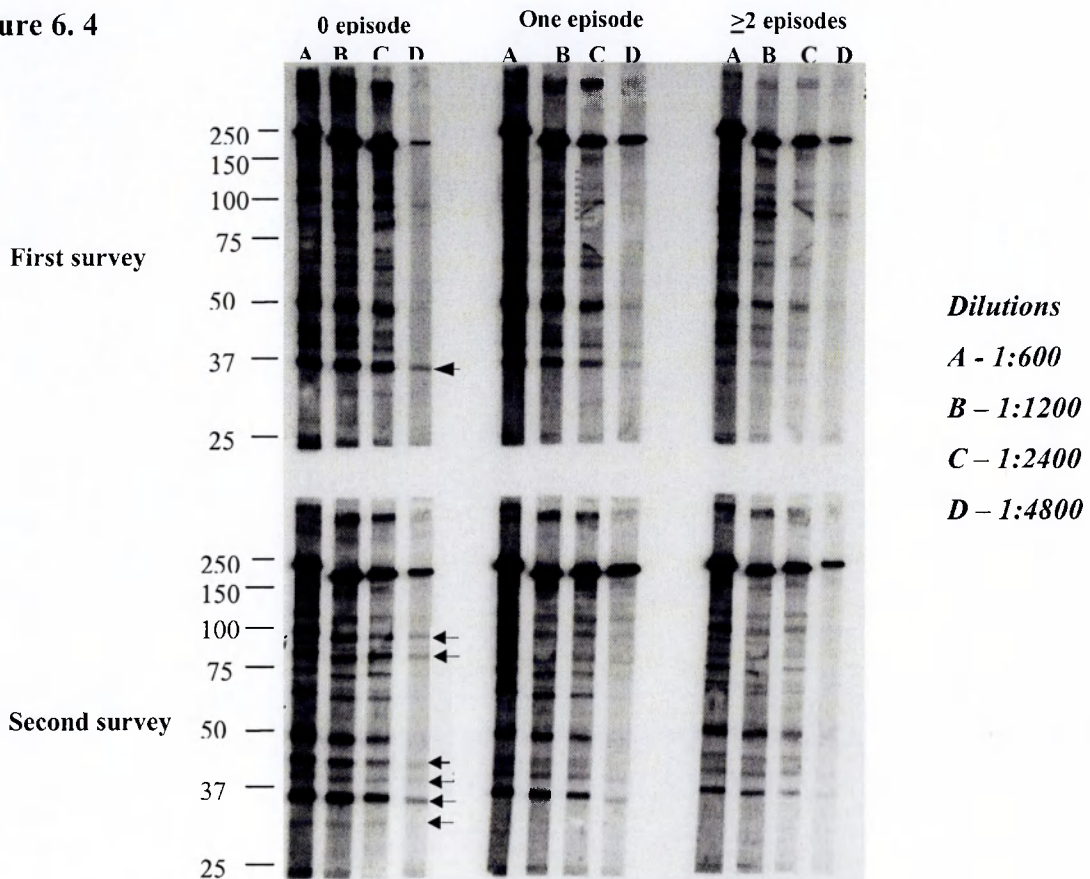

IgG responses in pooled plasma from immune (0 episodes), semi-immune (1 episode), and non-immune (≥ 2 episodes) children. The arrows indicate the responses that were reduced in non-immune children

Isotypes of antibodies directed against schizont antigens (Fig 6.5)

We did not detect IgM antibodies against schizont antigens in pooled plasmas in these study subjects. However, the anti-human-IgM HRP conjugate we used had not been validated for use in western blots, it may be that the failure to detect this isotype is due technical reasons rather than a real absence of the isotype.

IgG1 and IgG3 dominated the response to majority of the bands. Although both non-immune pool and immune pools had IgG1 antibodies to most of the bands, the titres were at least 5 times as high in the immune as they were in the non-immune pools (1:100 Vs 1:500). IgG3 responses to the 88, 75, 63, 56, 40 and 36 kDa bands were virtually absent in the non-immune pool from the first survey while those to the 130, 100 and 47 kDa bands were much reduced in the same pool compared to the immune pool. There was an enhancement of IgG3 response to 47, 40, and 36 kDa bands in the non-immune pools by the end of the first year of follow-up

IgG2 and IgG4 responses against most of the bands were absent in the two sets of pools that were assayed (non-immune first and second survey, immune first and second survey). Low titres (1:50) IgG2 and IgG4 response to the 250, 130, 100, 47 and 36 kDa bands were observed mainly in the immune pools.

6.5 DISCUSSION.

The identification of malaria parasite antigens that are putative targets for protective immune response against malaria is a prerequisite for the development of an effective malaria vaccine. Several methods including Western blots, ELISA, immunoprecipitation and more recently screening of expression libraries have been used in identifying important malaria

antigens. All these techniques employ the use of “immune sera” as a screening reagent. Because distinguishing between immune responses that are markers of protection and those that are marker of exposure is difficult in malaria, the definition of immune sera especially in a natural setting is often imprecise. We have already described a longitudinal framework that was used to study various aspects of immune response to PIESA and through which we obtained precise details about individuals’ disease experience. We therefore considered the same framework appropriate for examining immune responses to other schizont- associated antigens.

Plasma from 127 individuals in whom malaria episodes were actively monitored for one year was assayed for antibodies to schizont antigens using Western blots. First, we assessed the reactivity of the plasmas with un-infected red cells. Weak reaction against a 220-250 kDa doublet band, 110 kDa, and 75 kDa band was observed. There is evidence to suggest that individuals in malaria endemic areas may develop antibodies against components of the red cell membrane (Brown, *et al.*, 1986). Antibodies against 80 kDa, 70 kDa, 40 kDa, 28kDa red cell polypeptides and the α subunit of spectrin have previously been observed in malaria-exposed individuals (Berzins, *et al.*, 1983). It likely that the large doublet band observed in this study corresponds to spectrin. These reactions were reduced to a minimum by increasing the incubation time with blocking buffer and more rigorous washing of the blot membrane before probing with the secondary antibody.

Figure 6.5

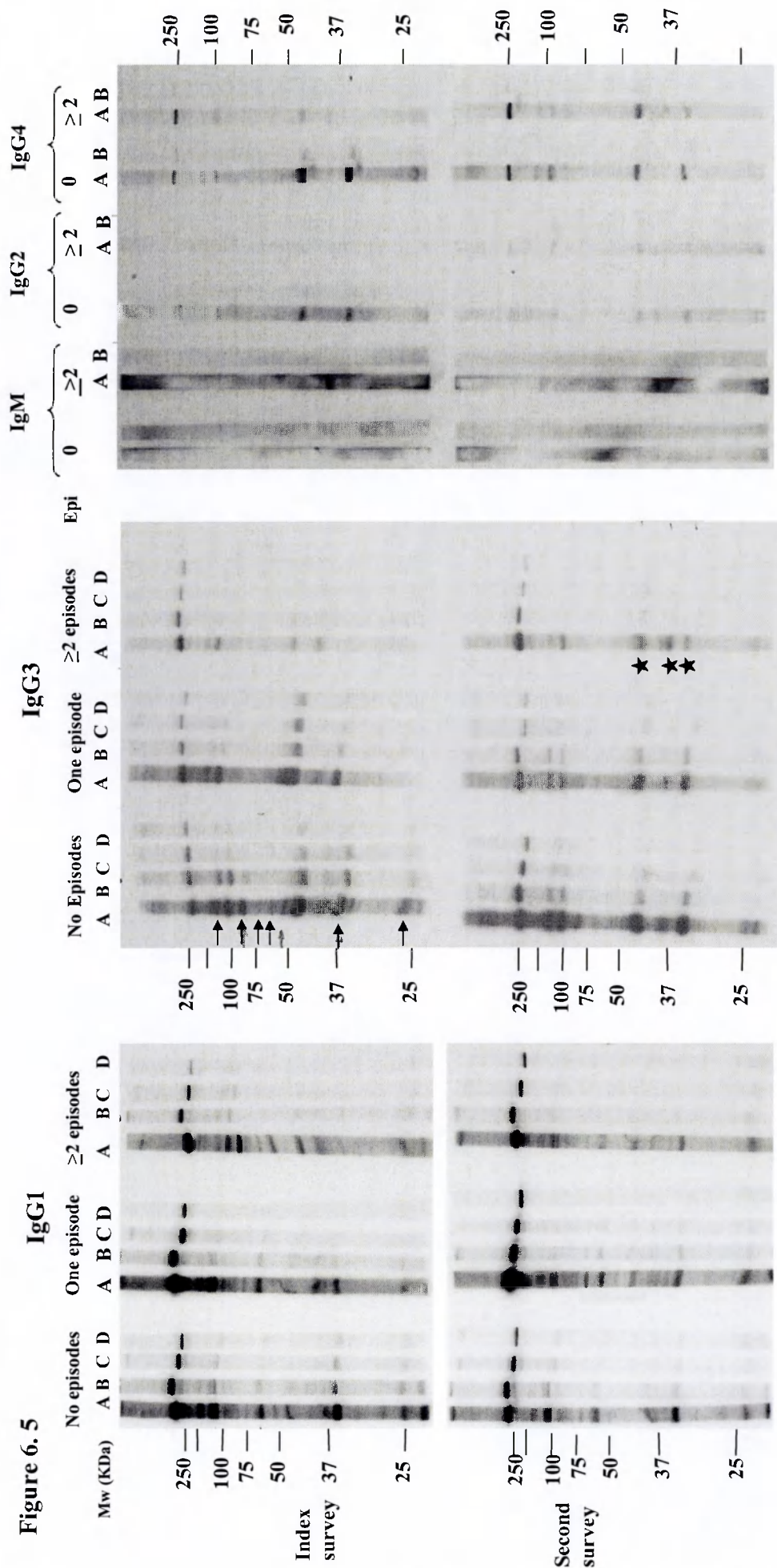

Isotypes of responses of pooled sera to schizont antigens. For IgG1 and IgG3 the pools were assayed at: A - 1:250, B - 1:500, C - 1:1000, D - 1:2000 dilution. Only pools from immune and non-immune children was assayed for IgM, IgG2 and IgG, each at A - 1:50 and B - 1:200 dilution. The arrows indicate IgG3 responses that were absent in the non-immune pools and the stars indicates responses that were enhanced during the second survey

Approximately 14 bands ranging from over 250 kDa to about 30 kDa were resolved on the gel. The prevalence of antibodies against these bands varied considerably with some bands being reacting with up to 60% of study subjects while others reacted with only a few individuals. Proteins of molecular weight above 200 kDa were poorly resolved and blotted and it is not possible to make much inference about them. However, responses to PIESA, some of which fall within this molecular weight range, were studied by other methods as already described. The prevalence of antibodies to most of the bands increased with age and with increasing immunity, but only the prevalence of antibodies to a 192-kDa protein was associated with protection against clinical malaria albeit not significantly. This molecular weight corresponds to the molecular weight of merozoite surface protein -1 (MSP-1), a protein that has been identified as a putative target for protective responses against malaria. However, it is not possible to say if the band seen here corresponds to MSP-1 without further work. The lack of association between protection and responses to all the other the antigens is consistent with reports from other studies which showed that responses to many malaria parasite antigens are not associated with protection (Hoffman, *et al.*, 1987; Marsh, *et al.*, 1989; Thelu, *et al.*, 1991; Miller, *et al.*, 1997).

Most of the individuals in this study had antibodies to one or more protein bands, indicating that they had been exposed to malaria parasites sometime in their life. As expected, the number of bands that an individual recognised increased with age. Age/exposure dependent acquisition of antibodies to various malaria antigens has been previously described in several studies. However, there were older (above 10 years of age) individuals who despite their age had antibodies to only a few of the bands. Plasma samples from these individuals were assayed along with other plasma that exhibited a broad range of responses and in addition, all samples that had antibodies to less than four bands were re-assayed. No difference was

observed between results from the first and second runs. Thus, the lack of responses observed in these plasmas was probably not due to a technical flaw.

The observation that these individuals were nonetheless immune to malaria disease (they did not present with a clinical episode during the follow-up period) supports the assertion that many of the responses measured here may be irrelevant to protection against clinical malaria. It should also be borne in mind that some protective responses against malaria may be directed against conformational epitopes on native proteins while proteins on a Western blot are in denatured form. Hence, the profile of responses to blotted proteins is not necessarily a good reflection of the individual's immune status. In addition, the domination of responses to some of the bands by IgG3 suggests the responses might be short-lived and hence their absence could reflect a lack of recent re-stimulation by recent malaria parasite infections. In this study, individuals who had concurrent infections during the cross-sectional survey showed a higher, albeit not significant, tendency to have a wider range of responses than those who were a parasitaemic (see analysis in chapter 7).

We categorized individuals as "immune", "semi immune", and "non-immune" according to their clinical malaria experience over the study period and pooled the plasmas of individuals in each category. We also pooled the corresponding plasmas from a second cross-sectional survey carried out a year later. The aim of this was to look for responses that were common to the individuals in each pool. The pools were titrated for IgM, IgG, and IgG isotypes against the blotted proteins. We failed to detect IgM in any of the pools. In the light of previous reports of high anti-malaria IgM levels in individuals from malaria endemic areas (Turner and Voller, 1966; Voller, *et al.*, 1971), it is unlikely that all the individuals in this study lacked anti-malaria IgM and more likely that our failure to detect IgM was due to the

some technical problem with the secondary antibody which had not been validated for use in Western blot. Quantitative and qualitative differences in the IgG and IgG subclass responses to the blotted proteins were observed between the immune and non-immune pools but less between immune and semi-immune pools. IgG titres to six bands were twice as high in the pooled second survey plasma from immune children compared to the levels in the corresponding non-immune pool.

Cytophilic antibodies dominated responses against most of the bands. Although all the pools had IgG1 antibodies to many of the bands, the titres were much higher in the immune compared to the non-immune pools. IgG3 responses to many of the bands were either markedly reduced or absent in non-immune pool. Poor IgG2 and IgG4 responses were observed in both immune and non-immune individuals. This skewed responses to schizont antigens towards cytophilic IgG antibodies have been reported for responses to ring-infected erythrocyte surface antigen (RESA) (Dubois, *et al.*, 1993; Beck, *et al.*, 1995), merozoites surface antigens 1& 2 (Taylor, *et al.*, 1995; Rzepczyk, *et al.*, 1997), schizont antigens (Thelu, *et al.*, 1991; Nguer, *et al.*, 1997); and PIESA (Piper, *et al.*, 1999) and have been associated with protection against malaria (Salimonu, *et al.*, 1982; Aribot, *et al.*, 1996; Ferreira, *et al.*, 1996).

An antibody dependent cellular inhibition (ADCCI) model in which cytophilic antibodies against merozoites attach to monocytes and mediate reversible inhibition of ring stage trophozoites has been proposed by Bouharoun-Tayoun *et al.* (1992). In this model, non-cytophilic IgG2 and IgG4 are said to antagonistic to the activities of the cytophilic subclasses. It is therefore possible the cytophilic responses that were increased among the immune individuals are markers of immunity rather than just exposure. Thus, further work could

focus on identifying the proteins corresponding to bands that reacted strongly with the cytophilic antibodies

In this study, we have identified a band of approximately 192 kDa protein that might correspond to antigens that are targets for protective responses against malaria. We have also shown that responses to the majority of schizont antigens are dominated by antibodies of the cytophilic subclasses (IgG1 and IgG3). Individuals who are immune to clinical episodes of malaria tend to have higher and qualitatively different responses to certain schizont antigens than non-immune individuals. Some of the bands against which the responses were directed have weights corresponding to those of antigens cited elsewhere in the literature. Antibodies to a 96 kDa antigen have been reported to be associated with protection against malaria (Nkomo-Akenji, *et al.*, 1993). The 33, 36, 42, and 47 kDa bands have molecular weights that correspond with fragments of the merozoites surface proteins MSP-1 and MSP-2, antibodies to which are associated with protection against malaria (Holder, *et al.*, 1985; Riley, *et al.*, 1992). It is not possible to identify the proteins that each band represents without further two-dimensional separation and proteomic analysis. Identification of the proteins corresponding to these bands could form the basis of further research work.

CHAPTER 7

THE RELATIONSHIP BETWEEN PARASITOLOGICAL STATUS AND ANTIBODY RESPONSES TO PIESA AND OTHER SCHIZONT ANTIGENS

7.1 INTRODUCTION

Although evidence from experimental infections in animal models suggests that chronic malaria infections could prevent super-infection by parasites of the same strain or species (Sinton, 1939; Singh and Singh, 1940), the evidence for the existence of such immunity in humans is scanty. Results from recent studies suggest that in humans, the multiplicity of the infection (Al-Yaman, *et al.*, 1997; Smith, *et al.*, 1999) or the concurrent presence of variant-specific antibody responses to PIESA (Bull *et al.*, in prep.) rather than the chronic infection *per se* may be the important factors in determining protection against super-infection. The mechanism that would underlie such type of immunity is yet to be established. Using data obtained from the longitudinal study described earlier on in this thesis, I explored the influence of parasitological status at the beginning of a period of active malaria episode surveillance on the magnitude and protective efficacy of pre-follow-up responses to PIESA and other schizont antigens.

7.2 STUDY DESIGN

A cross-sectional survey was carried out in September 1998 prior to a 2-year active malaria episode surveillance. During the survey, the parasitological status of 256 children under the age of 10 was assessed by microscopy. At the same time, a plasma sample was obtained from the children and assayed by flow cytometry for anti-PIESA antibodies against a panel of 9 isolates.

The longitudinal framework within which the clinical episode surveillance was carried out is described in fuller details in chapter 2 while the details of the assessment of anti-PIESA response by flow cytometry are given in chapter 5. I examined whether being parasitaemic at the cross-sectional survey influenced the protective efficacy of antibody responses to various PIESEA variants. In addition, I assessed the effect of being parasitaemic on the protective efficacy of antibody responses to schizont antigens separated on a western blot described in chapter 6.

Data analysis

All the data analysis was carried out using STATA 6.0. Various relationships between parasitological status, anti-PIESA responses, or response to schizont antigens, and the odds of presenting with at least one clinical episode of malaria during the follow-up were examined using logistic regression models. To assess the interactions between these parameters, they were first converted into binary categories of positive and negative, and then interaction variables were generated by multiplying the parameters and incorporated into logistic regression models. The following associations were examined:

1. The effect of parasitological status on the breadth of each child's antibody repertoire (as determined by responses to at least one of the test isolates, or four specific protein bands on the blot in the case of schizont antigens). Adjustments were made for age and the children's subsequent disease experience.
2. The association between parasitological status and the prevalence of antibodies to each of the test isolates or protein bands adjusted for age and the children's subsequent disease experience

1. The association between parasitological status and protection against clinical episodes by antibodies to PIESA and schizont antigens adjusted for age and other apparently protective responses and interaction.

7.3 RESULTS

Prevalence of microscopically-detectable infections. (Fig 7.1)

89/256 (34.8%) children had a microscopically-detectable infection during the cross-sectional survey of these 89 children, 19 were febrile (axillary temp. >37.49) and were treated with Fansidar (sulphadoxine / pyrimethamine). The prevalence of infections increased from birth to a peak among two year old children then declined slightly among the three and four year old children after which it continued to increase with age (OR - 1.76, 95% CI. 1.064 – 2.913, P=0.028)

Figure 7.1

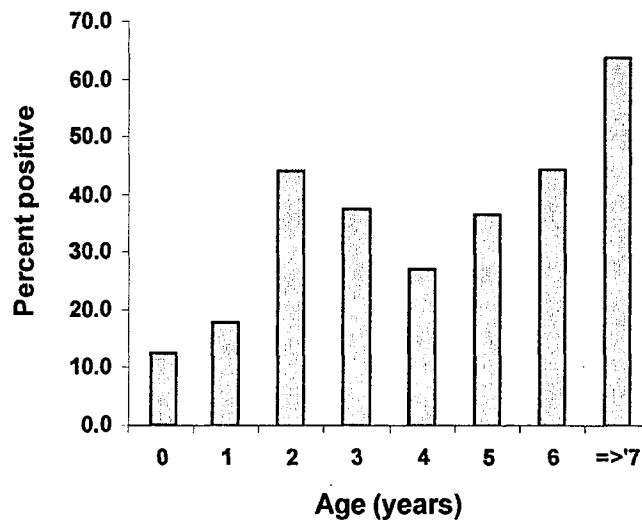

The prevalence of microscopically-detected infections stratified by age (n=256)

Association between parasitological status and an individual's repertoire of anti-PIESA specificities

Having anti-PIESA antibodies to at least one of the test isolates was taken as an indicator of the children's breadth of anti-PIESA antibody repertoire. Being parasitaemic was positively associated with a wider repertoire of anti-PIESA response among the future controls (OR – 35.373, 95%CI: 4.465 – 280.227, P=0.001) but was negatively associated (OR - 0.058, 95%CI: 0.005 – 0.603, P=0.017) among the future cases.

Association between parasitological status and anti-PIESA responses (Table 7.1)

Among the future controls, being parasitaemic was positively associated with the odds of having anti-PIESA responses to each of the test isolates. Among the future cases, parasite positivity was associated with reduced odds of being antibody positive and this reduction was significant in two instances. Fever status did not influence the associations above. A summary of the odds ratios is given in table 7.1. Interactions with responses to isolate B7 are not reported because their low prevalence among the study children resulted in unrealistic estimates of odds ratios.

Table 7.1

Isolate	Future controls		Future cases	
	Odds ratio (95% CI)	P	Odds ratio (95% CI)	P
A4	4.357 (1.926 – 9.851)	<0.001	0.200 (0.061 – 0.660)	0.008
ITGIC15	3.968 (1.786 – 8.818)	0.001	0.518 (0, 162 – 1.657)	0.268
4518	2.918 (1.162 – 7.331)	0.023	0.586 (0.160 – 2.137)	0.418
4451	3.247 (1.326 – 7.956)	0.010	0.987 (0.253 – 3.853)	0.984
1776	9.717 (3.536 – 26.704)	<0.001	0.265 (0.059 – 1.186)	0.082
3030	13.451 (4.823 – 37.516)	0.001	0.203 (0.054 – 0.730)	0.019
1509	3.982 (1.630 – 9.720)	0.002	0.177 (0.045 – 0.693)	0.013

The odds ratio of children having anti-PIESA responses to the test isolates if they were parasite positive adjusted for age and stratified by future disease experience.

Association between parasitological status and protection against clinical episodes of malaria by anti-PIESA antibodies . (Table7.2)

In chapter 5, I reported that only responses to isolate 1776 were associated with protection against clinical episodes of malaria after correcting for age and responses to other isolates (Fig. 5.4A). Here I have re-analysed the data to test for the influence of concurrent parasitaemia on the protective efficacy of anti-PIESA responses. Having both parasites and antibodies to isolates 1509, 3030 and A4 was significantly associated with protection against episodes in the first year of follow-up. However, only the interaction between being parasitised and having responses to isolate 1509 remained significantly associated with protection even after correcting for age and the other apparently protective interactions. Antibodies to isolate 1509 and being parasitaemic

were each independently associated with increased susceptibility to clinical episodes, (table 7.2). Interaction between parasites and responses to isolate ITGIC15 was found to be associated with protection in the second year. Having responses to isolate 1776 and concurrent infection was associated with protection against clinical episodes, though not significantly (OR – 0.264, 95% CI: 0.061 – 1.150, P= 0.076).

Association between parasitological status and antibody response to malaria antigens on a Western Blot

In chapter 6, I examined the association between possession of antibodies to various schizont antigens separated on a Western blot and protection against clinical episodes of malaria. Only responses to a 192 KDa protein were significantly associated with protection. Here I have examined the response data from chapter 6 to determine if there is a protective interaction between concurrent malaria infection and response to schizont antigens. I arbitrarily chose the ability to react positively with at least four protein bands as a measure of the breadth of responses to schizont antigens. Being parasitaemic was associated with an increased breadth of response, albeit not significantly (OR- 2.251, 95% CI: 0.870 – 5.823, P=0.094) in future controls but not in future cases (OR -0.856, 95% CI: 0.123 – 6.111, P=0.885). Although responses to some of the schizont antigens showed a slight tendency to be raised while others tended to be reduced among the parasite positive children, none of the associations was statistically significant. There was no significant interaction between responses to any of the 14 protein bands described earlier on and parasitological status in relation to protection against subsequent clinical episodes.

Table 7.2A

Isolate	Parameter	Adjusted for age	P	Adjusted for age and other responses. ‡	P
A4	Parasite + Abs	0.200 (0.062 – 0.647)	0.007	0.343 (0.095 – 1.256)	0.106
	Abs only	1.724 (0.847 – 3.500)	0.133	1.784 (0.872 – 3.650)	0.113
	Parasites only	1.844 (0.878 – 3.878)	0.106	3.097 (1.029 – 9.319)	0.044
3030	Parasite + Abs	0.194 (0.522 – 0.722)	0.014	0.308 (0.075 – 1.264)	0.102
	Abs only	1.784 (0.914 – 3.480)	0.090	1.930 (0.972 – 3.832)	0.060
	Parasites only	2.744 (0.923 – 8.161)	0.069	3.285 (1.082 – 9.971)	0.036
1509	Parasite + Abs	0.128 (0.342 – 0.476)	0.002	0.196 (0.048 – 0.910)	0.023
	Abs only	2.276 (0.959 – 5.399)	0.062	2.626 (1.066 – 6.472)	0.036
	Parasites only	1.702 (0.866 – 3.345)	0.123	3.057 (1.021 – 9.154)	0.046

B

ITGIC15	Parasite + Abs	0.177 (0.049 – 0.644)	0.009
	Abs only	0.913 (0.434 – 1.923)	0.811
	Parasites only	2.194 (1.027 – 4686)	0.043

The odds ratios (95% Confidence interval) of a child suffering a clinical episode during the first (A) and second year (B) of follow-up in relation to parasitisation and anti-PIESA responses. Abs – antibodies. ‡ Adjusted for responses to the other apparently protective interactions including responses to isolate 1776. No adjustment for other responses was necessary in table B. Significant OR are highlighted in bold font. Responses where no significant associations were observed are not included.

7.4 DISCUSSION

Immunity to malaria is usually not complete and many people in endemic areas often harbour chronic asymptomatic infections (Marsh, 1992). Data from animal malaria models suggest that chronic infections might prevent the establishment of super-infections in a strain or species-specific manner (Sinton, 1939; Singh and Singh, 1940). Although the idea of “premunity” in malaria dates back to 1935 when Sargent and Parrot coined the term for this type of immunity, the mechanisms underlying premunity remain poorly understood. Data on premunity in humans is scanty although the available data suggests that it may be associated with the number of clones or “strains” in a chronic infection (multiplicity) rather than the infection *per se* (Al-Yaman, *et al.*, 1997; Smith, *et al.*, 1999). The multiplicity of an infection can be defined with respect to polymorphic antigens such as MSA-1, MSA-2, and PIESA. Unpublished observations by Bull *et al* suggest that chronic infections might interact synergistically with response to some PIESA variants in the protection against clinical episodes of malaria. I have examined data on responses to PIESA and other schizont antigens separated on a Western blot from 256 and 126 children from Kilifi respectively to see if such an interaction would be evident.

89/256 (35%) children were parasitaemic at the pre-follow-up survey. The increase in parasite prevalence with age appeared to be biphasic with a short peak occurring in the two-years age group and a second one in the group of above 7 years in age. The rise in prevalence to about 70% among children aged 7-10 years is consistent with findings of a previous larger study, involving 2346 individuals resident in this same study area, which reported an overall prevalence of 50% (Lowe, 1999). The peak at two years is difficult to explain although it could simply be due to the relatively small sample size. 19 children were febrile in addition to being parasitaemic. Although

this number might be too small to base any firm conclusions on, fever status did not significantly affect either future disease experience or levels of antibodies to PIESA and other schizont antigens. As such, we did not attempt to distinguish between chronic and acute infections in the analyses. The febrile children were treated with anti-malarial drugs. It is not clear how elimination of the parasites affected the development of concomitant immunity. However, it should be noted that even children who did not receive anti-malarial drugs during the survey might still have spontaneously cleared the infections eventually. Thus, it might not be possible here to talk about premunition in the strict sense of a chronic infection preventing super-infections; nonetheless, the protective effects of chronic infections in animal models have been shown to linger on for even seven months after spontaneous or chemotherapeutic clearance of the infection (Sinton, 1939; Singh and Singh, 1940).

There are several ways in which chronic malaria infections might appear to be associated with protection against malaria super-infections and disease. First, chronic infections might in themselves not be protective and instead the ability to maintain them might reflect well-developed malaria immunity. Second, chronic infection might cause a generalised non-specific up-regulation of responses against malaria antigens. Third, chronic infections might induce or boost protective variant-specific responses to polymorphic antigens such as PIESA and prevent super-infection by parasites bearing homologous antigenic variants. Although as stated earlier, we cannot verify that the infections seen here were strictly chronic, the observation in this study that merely being parasitaemic was actually associated with increased susceptibility to clinical episodes rather than protection suggests that the first possibility cannot explain premunition. This

observation corroborates with observations in other studies both in Kilifi (Bull, unpublished obs.) and elsewhere (Al-Yaman, *et al.*, 1997; Smith, *et al.*, 1999).

In order to explore the second possibility, I examined the effect of parasitisation on an individual's repertoire of antibody to PIESA variants and to other schizont antigens in two ways. First, by examining the odds of having anti-PIESA antibodies to at least one of the test isolates, or having antibodies to at least four of the 14 schizont protein bands seen on a western blot among parasitised children compared to non-parasitised children. Second, I examined the odds of having antibodies to each of the nine test isolates and 14 protein bands. In both analyses, only the odds ratios of having anti-PIESA responses to the test isolates were apparently increased by the presence of parasites and this was only among children who did not subsequently present with clinical episodes during the first year of follow-up. These data clearly show that among the children in this study, being parasitised was not necessarily accompanied by a generalised up-regulation of immune responses to all malaria antigens. There is nonetheless a group of children within whom having microscopically detectable infection might have resulted in the induction or boosting of variant-specific responses to PIESA. This observation is consistent with the results discussed in chapter 4 of this thesis, where both asymptomatic and symptomatic infections were shown to contribute to the acquisition of new anti-PIESA specificities.

Given the variant-specificity of responses to PIESA the question of how an infection might induce response to an apparently heterologous set of variants has been a difficult one to answer. A possible explanation is that there is a degree of specificity overlap in the PIESA expressed in the chronic infection. Alternatively, chronic infections may be in the host for a sufficiently long

period to allow the expression of a large number of PIESA variants, including those that are cross-reactive with the test variants, through antigenic variation. In view of this up-regulation, one would expect to see an increase in prevalence of anti-PIESA response to any given set of isolates in plasma samples taken after a transmission season when nearly all children develop detectable infections. The observed loss of anti-PIESA specificities (chapter 4) in children sampled within three months of a peak transmission period (May - June) therefore suggests that these “heterologously” induced responses are short-lived. On the other hand, the observations described in chapter 3 suggest that responses to homologous parasites persist for more than 3 months an acute episode.

There is strong evidence from the results reported in chapter 5, work done in Kilifi (Bull, *et al.*, 1998), in the Gambia (Marsh, *et al.*, 1989) in Ghana (Dodoo, *et al.*, 2001) and in the Sudan (Giha, *et al.*, 2000) to suggest that responses to PIESA protect against malaria disease. Thus, the question that followed on from the observations above is whether the raised anti-PIESA responses in the parasitaemic children translated into apparent protection against clinical episodes during the follow-up. Except for response to isolate 1776, possession of anti-PIESA response to the other isolates was not independently associated with protection. In fact, responses to isolate 1509 were independently associated with increased susceptibility to disease episodes. On the other hand, possession of antibodies to isolate 1509 and being concurrently parasitised was associated with a nearly 8-fold reduction in the odds ratio of presenting with a clinical episode in the first year of follow-up. Being parasitised was independently associated with a three-fold increase in the odd ratio of suffering a clinical episode. Concurrent parasitisation and possession of antibodies to isolate ITGIC15 was associated with protection in the second year.

These data suggest that being parasitised could reflect poor malaria immunity in some children; such children have increased risk of becoming ill with malaria sometime during follow-up. These children appear to have reduced anti-PIESA responses to the test isolates. It not clear whether these poor responses were the result or the cause of their poor immune status. The finding that having anti-PIESA antibodies to some of the isolates in the absence of a concurrent infection was associated with increased odds of experiencing a clinical episode of malaria is interesting. Previous studies have shown that response to only some rather than all isolates appear to be associated with protection against clinical episodes (Marsh, *et al.*, 1989; Giha, *et al.*, 2000; Doodoo, *et al.*, 2001) but no previous studies have shown that response to some isolates might actually be adversely associated with malaria disease. This is possibly because in the other studies no adjustment was made for parasitisation in the analyses. The mechanism by which such antibodies might make one susceptible to malaria requires further studies to unravel

Although anti-PIESA responses to isolates such as 1776 might be independently associated with protection, responses to other isolates such as 1509 are only associated with protection in the presence of a concurrent infection. There is evidently some synergistic interaction between other immune responses induced by the infection and the response to PIESEA in mediating protection against malaria. The fact that this interaction was apparent with anti-PIESA response to only some and not all the isolates suggests that even the other responses might be directed against polymorphic targets. Thus, only responses to a particular combination of PIESEA variant and variants of the other targets are protective.

In summary, these data show that parasitisation has an effect on the level of anti-PIESA antibodies, but this does not necessarily translate into protection against malaria. Some PIEsa response may be interact with other responses induced by concurrent parasitisation but the mechanism of how this happens is not clear. There is therefore need to take into account possible confounding effects of parasitisation when examining the protective efficacy of responses to PIEsa and other antigens.

CHAPTER 8

SUMMARY

In this thesis, I have examined the natural history of humoral responses to the parasite-induced antigens on the surface of red cells infected by mature stages of *P. falciparum* (PIESA) and to other schizont antigens. The justification for carrying out these studies lies in the fact that despite the increasing evidence that variant-specific antibody responses to PIESEA may be protective against malaria (Marsh, et al., 1989; Alles, et al., 1998; Bull, et al., 1998; Giha, et al., 2000; Doodoo, et al., 2001), the natural history of these responses is still poorly documented. This is partly because the longitudinal studies required to provide these data are difficult and costly to set up. The KEMRI/Wellcome Trust Centre in Kilifi has over time acquired the skills and facilities to set up longitudinal frameworks within which sufficiently reliable data can be obtained. Thus, it is an appropriate set-up in which to carry out these studies.

Materials and Methods

Prior to the actual studies, I carried out experiments to validate the methods that I intended to use. This was necessary in order to determine the assays' optimum conditions and level of inherent variations. Two methods were used to study responses to PIESEA: agglutination and flow cytometry. Agglutination assays have been reported to be susceptible to inter-assay variations (Aguilar, et al., 1992; Reeder, et al., 1994; Bull, et al., 1999), partly because agglutinates are scored subjectively. The scoring method used in these studies was shown to be highly reproducible but some degree of inter-assay variation was still observed between duplicate assays confirming the inherent variability of agglutination assays. I made several modifications to the two methods in order to facilitate the comparative experiments carried out

these studies. First, I used dried agglutination smears, which give similar results to the standard wet preparations (Bull, et al., 1999) but have a much longer storage span than the latter. Second, in order to circumvent the problems associated with poor recovery and maturation in in-vitro culture of cryopreserved ring trophozoites, I adopted the use of cryopreserved schizonts as sources of parasite materials for the studies against PIESA responses. Using mixed agglutination assays (Newbold, et al., 1992) and by comparing agglutination and flow cytometry profiles of frozen and fresh parasites I showed that freezing schizonts did not significantly alter their PIESA phenotype.

Kinetics of anti-PIESA responses to homologous Parasites

Most of the studies on anti-PIESA responses to homologous parasites are restricted to the first few weeks after an episode (Forsyth, et al., 1989; Marsh, et al., 1989; Aguiar, et al., 1992; Iqbal, et al., 1993; Bull, et al., 1998). No previous study has tracked the rise and decay of the responses over a longer period. I monitored the kinetics of anti-PIESA responses for 12 weeks after acute episode of malaria. Agglutination antibody levels were monitored for 6 weeks after the episode in 26 children and for 12 weeks in another 22 children. The results were consistent with the previous reports that children mount anti-PIESA responses within two weeks of a malaria episode (Forsyth, et al., 1989; Marsh, et al., 1989; Aguiar, et al., 1992; Iqbal, et al., 1993; Bull, et al., 1998). The majority of children were able to sustain the high antibody levels for over 12 weeks. However, a number of children showed a rapid decay in responses after the peak in the second week. This could be due to either parasite or host-related factors. A larger study is needed to confirm these observations and to examine other immune responses to malaria in such children.

Analysis of the isotype profiles of responses from 11 of the children showed that they were typical of a primary response, with IgM dominating the early part of the responses. This is consistent with the idea that children are not infected by isolates against which they already have anti-PIESA responses (Bull, *et al.*, 1998). As with IgG responses to other malaria antigens (Beck, *et al.*, 1995; Taylor, *et al.*, 1995; Rzepczyk, *et al.*, 1997), IgG responses to PIESEA appear to be strongly skewed toward IgG3. Although the number of children where isotype analysis was done was small and therefore no inferences can be reliably made, there is a hint that the failure to sustain high antibody titres in some children may be due to a failure to switch from the IgM to IgG. There is clearly a need for further work to confirm the profiles seen here and to address the question of how malaria parasites influence isotype switching in B-cells.

The dynamic of the acquisition of Anti-PIESA antibodies over time

It has been suggested that the development of immunity to malaria might involve the accumulation of antibody specificities to the locally circulating repertoire of PIESEA variants (Gupta and Day, 1994). However, the process by which these specificities are accumulated is poorly documented. I used agglutination assays and flow cytometry to explore the dynamics of the accumulation of anti-PIESA specificities in children in Kilifi. All the children showed considerable variation in their anti-PIESA specificity repertoire over a period of one year. Both the loss of pre-existing specificities and acquisition of novel ones were observed. Evidently, antibodies to some PIESEA variants are accumulated more rapidly than others are and the rate of accumulation appears to be a function of how often the variant is encountered in the transmission system. Although both symptomatic and asymptomatic infections appear to be important in the

acquisition of novel specificities, symptomatic infections might be more efficient in maintaining detectable levels of specific response. The briefness of anti-PIESA responses seen in these studies might reflect the domination of the responses by IgG3 antibodies, which have a shorter half-life than the other IgG sub-classes. Whether after this apparent loss of antibodies, the children are able to mount good memory responses to future infections by a homologous PIESEA variant is a question that needs to be addressed.

Protection against clinical episodes of malaria by anti-PIESA responses

In view of the variant-specificity of anti-PIESA responses (Newbold, et al., 1992), the apparently heterologous protection against malaria episodes by anti-PIESA antibodies to randomly selected isolates reported in studies in the Gambia (Marsh, et al., 1989), the Sudan (Giha, et al., 2000) and in Ghana (Dodoo, et al., 2001), was rather surprising and difficult to explain. I attempted to address this question in this thesis first by looking for evidence of the occurrence of such protection among children in Kilifi. Second, I considered the relationship between the association of anti-PIESA responses to an isolate and the relative frequency with which the isolate was encountered in the transmission system in Kilifi. The results supported the findings from the studies cited above, that responses to some but not all isolates may be associated with protection against malaria episodes. This study did not resolve the question of the underlying mechanism. However, the results showed that in Kilifi the association between protection and anti-PIESA responses to a given isolate was not necessarily correlated with the relative frequency with which the isolate was encountered in the transmission system.

Assessment of the protective efficacy of responses to schizont antigens using Western blots

It is certain that besides PIESA, there are other malaria antigens that are targets for protective responses. To identify such antigens and responses requires precise definition of the immune status of the sera used in the screening process. The longitudinal framework set up to look at responses to PIESA provided a detailed history of disease experience of the study subjects during the follow-up period. This history was taken to be a good reflection of the subjects' immune status. Thus, the framework also provided an opportunity to explore the association between responses to other schizont antigens and protection against clinical episodes of malaria. When plasma samples from 126 individuals in the longitudinal surveillance were probed for antibodies against schizont antigens on a Western blot, only responses to a 192 kDa antigen band were found to be associated with reduced odds of disease episodes. More work is required to identify the proteins represented by this band. The lack of association between responses to most of the schizont antigens and protection is consistent with the idea that responses to the majority of malaria antigens are simply evidence of exposure, and do not confer protection. Some of these responses might be mechanisms by which parasites subvert protective responses (Hoffman, et al., 1987; Marsh, et al., 1989; Thelu, et al., 1991; Miller, et al., 1997).

Individuals were classified as immune, semi-immune, non-immune, and plasmas from each group pooled. Isotype analysis of the responses was done on the plasma pool. Cytophilic IgG1 and IgG3 antibodies dominated the responses to all the bands. The titres of both subclasses were higher in the immune pool than in the non-immune pool. IgG3 responses to several of the bands were virtually absent in the non-immune pool. In view of the reported association of cytophilic

antibody response with protection against malaria (Salimonu, *et al.*, 1982; Aribot, *et al.*, 1996; Ferreira, *et al.*, 1996), it is possible that the IgG3 responses that were exclusively seen in pooled immune plasma are markers of immunity rather than just exposure. Thus, their target antigens could be the focus of future studies.

The influence of parasitological status on the levels and protective efficacy of responses to PIESA and other schizont antigens

It has been speculated for sometime now that chronic infections may protect against super-infections but recent studies suggest that in humans, the protection is related to the multiplicity of infection rather than the infection *per se* (Smith, *et al.*, 1999). A finding of particular interest in this study and which has also been observed in another study in Kilifi (Bull, in prep.) is the interaction between concurrent infections and anti-PIESA responses in the protection against clinical episodes. Although being parasitaemic was associated with raised levels responses to anti-PIESA and increased range of responses to other schizont antigens, this was probably not the reason for the protection as having anti-PIESA responses to some of the isolates in the absence an of infection and vice versa was in fact associated with increased risk of subsequent clinical episodes of malaria. The observation that the protection conferred by the interaction between the two parameters was restricted to anti-PIESA responses to one rather than all the test isolates suggests that there may be some variant-specific synergy between anti-PIESA responses and responses to other polymorphic malaria antigens.

Final comments

This thesis adds strength to our current knowledge about immune responses to PIESA. In addition, it has revealed several aspects that were not previously documented. The conservation

of PIESA phenotype in cryopreserved schizonts; the kinetics and isotype profiles of anti-PIESA responses in children; the dynamics of anti-PIESA responses over a long period in children resident in an area of moderate malaria transmission and the protective interaction between infections and anti-PIESA responses to some isolates. The numbers of study subjects involved in some of the analyses were rather low and a larger study might be necessary to confirm the current conclusions. While this thesis adds to our general understanding of anti-PIESA responses there is clearly a need for further research aimed at understanding the underlying mechanisms.

REFERENCES

- Abdalla S, (1990), Haematopoiesis in human malaria. *Blood-Cells*. 1990; 16(2-3): 401-16
- Adams JH, Sim BK, Dolan SA, Fang X, Kaslow DC, *et al.*, (1992), A family of erythrocyte binding proteins of malaria parasites. *Proc. Natl. Acad. Sci. USA* 89(15): 7085-9.
- Aggarwal A, Kumar S, Jaffe R, Hone D, Gross M, *et al.*, (1990), Oral Salmonella: malaria circumsporozoite recombinants induce specific CD8+ cytotoxic T cells. *J. Exp. Med.* 172(4): 1083-90.
- Aguiar J, Albrecht G, Cegielski P, Greenwood B, Jensen J, *et al.*, (1992), Agglutination of *Plasmodium falciparum*-infected erythrocytes from East and West African isolates by human sera from distant geographic regions. *Am. J. Trop. Med. Hyg.* 47(5): 621-32
- Aidoo I and Udhayakumar I, (2000), Field studies of cytotoxic T lymphocytes in malaria infections: implications for malaria vaccine development. *Parasitol. Today* 16(2): 50-6.
- Aidoo M, Lalvani A, Allsopp CE, Plebanski M, Meisner SJ, *et al.*, (1995), Identification of conserved antigenic components for a cytotoxic T lymphocyte-inducing vaccine against malaria. *Lancet* 345(8956): 1003-7.
- Aikawa M, (1988), Human cerebral malaria. *Am. J. Trop. Med. Hyg.* 39(1): 3-10.
- Aikawa M, Iseki M, Barnwell JW, Taylor D, Oo MM, *et al.*, (1990), The pathology of human cerebral malaria. *Am. J. Trop. Med. Hyg.* 43(2 Pt 2): 30-7.
- Aley SB, Sherwood JA and Howard RJ, (1984), Knob-positive and knob-negative *Plasmodium falciparum* differ in expression of a strain-specific malarial antigen on the surface of infected erythrocytes. *J. Exp. Med.* 160(5): 1585-90.
- Allen SJ, O'Donnell A, Alexander ND, Alpers MP, Peto TE, *et al.*, (1997), alpha+-Thalassemia protects children against disease caused by other infections as well as malaria. *Proc. Natl. Acad. Sci. USA* 94(26): 14736-41.
- Alles H, Mendis K and Carter R, (1998), Malaria mortality rates in South Asia and Africa: Implications for malaria control. *Parasitol. Today* 14(9): 369 - 371
- Al-Yaman F, Awburn M and Clark I, (1997), Serum creatinine levels and reactive nitrogen intermediates in children with cerebral malaria in Papua New Guinea. *Trans. Roy. Soc. Trop. Med. Hyg.* 91(3): 303-5
- Al-Yaman F, Genton B, Reeder J, Anders R, Smith T, *et al.*, (1997a), Reduced risk of clinical malaria in children infected with multiple clones of *Plasmodium falciparum* in a highly endemic area: a prospective community study. *Trans. Roy. Soc. Trop. Med. Hyg.* 91(5): 602-5
- Al-Yaman F, Genton B, Reeder J, Mokela D, Anders R, *et al.*, (1997b), Humoral response to defined *Plasmodium falciparum* antigens in cerebral and uncomplicated malaria and their relationship to parasite genotype. *Am. J. Trop. Med. Hyg.* 56(4): 430-5
- Anders RF and Smythe JA, (1989), Polymorphic antigens in *Plasmodium falciparum*. *Blood* 74(6): 1865-75.
- Andersen E, Jones T, Purnomo, Masbar S, Wiady I, *et al.*, (1997), Assessment of age-dependent immunity to malaria in transmigrants. *Am. J. Trop. Med. Hyg.* 56(6): 647-9
- Anstey N, Granger D and Weinberg J, (1997), Nitrate levels in malaria [letter; comment] CM: Comment on: *Trans. Roy. Soc. Trop. Med. Hyg.* 1996 Jan-Feb;90(1):44-7. Comment on: *Trans. Roy. Soc. Trop. Med. Hyg.* 1996 May-Jun;90(3):270-3. *Trans. Roy. Soc. Trop. Med. Hyg.* 91(2): 238-40
- Aribot G, Rogier C, Sarthou J, Trape J, Balde A, *et al.*, (1996), Pattern of immunoglobulin isotype response to *Plasmodium falciparum* blood-stage antigens in individuals living in a holoendemic area of Senegal (Dielmo, west Africa). *Am. J. Trop. Med. Hyg.* 54(5): 449-57

- Ayala FJ, Escalante AA and Rich SM, (1999), Evolution of *Plasmodium* and the recent origin of the world populations of *Plasmodium falciparum*. *Parassitologia* 41(1-3): 55-68.
- Babiker H, Ranford-Cartwright L, Currie D, Charlwood J, Billingsley P, *et al.*, (1994), Random mating in a natural population of the malaria parasite *Plasmodium falciparum*. *Parasitology*. 109 (Pt 4): 413-21
- Babiker HA, Abdel-Muhsin AA, Hamad A, Mackinnon MJ, Hill WG, *et al.*, (2000), Population dynamics of *Plasmodium falciparum* in an unstable malaria area of eastern Sudan. *Parasitology* 120(Pt 2): 105-11.
- Baird J, (1995), Host age as a determinant of naturally acquired immunity to *Plasmodium falciparum*. *Parasitol. Today* 11(3):105-111
- Barnwell J, Howard R, Coon H and Miller L, (1983a), Splenic requirement for antigenic variation and expression of the variant antigen on the erythrocyte membrane in cloned *Plasmodium knowlesi* malaria. *Infect. Immun.* 1983 Jun; 40(3): 985-94
- Barnwell J, Howard R and Miller L, (1983b), Influence of the spleen on the expression of surface antigens on parasitized erythrocytes. *Ciba-Found-Symp.* 1983; 94: 117-36
- Barnwell JW, Howard RJ and Miller LH, (1982), Altered expression of *Plasmodium knowlesi* variant antigen on the erythrocyte membrane in splenectomized rhesus monkeys. *J. Immunol* 128(1): 224-6.
- Barnwell JW, Asch AS, Nachman RL, Yamaya M, Aikawa M, *et al.*, (1989), A human 88-kD membrane glycoprotein (CD36) functions *in vitro* as a receptor for a cytoadherence ligand on *Plasmodium falciparum*-infected erythrocytes. *J. Clin. Invest.* 84(3): 765-72.
- Barragan A, Kremsner PG, Weiss W, Wahlgren M and Carlson J, (1998), Age-related buildup of humoral immunity against epitopes for rosette formation and agglutination in African areas of malaria endemicity. *Infect. Immun.* 66(10): 4783-7.
- Barragan A, Kremsner PG, Wahlgren M and Carlson J, (2000), Blood group A antigen is a coreceptor in *Plasmodium falciparum* rosetting. *Infect. Immun.* 68(5): 2971-5.
- Baruch D, Pasloske B, Singh H, Bi X, Ma X, *et al.*, (1995), Cloning the P. *falciparum* gene encoding PfEMP1, a malarial variant antigen and adherence receptor on the surface of parasitized human erythrocytes [see comments] CM: Comment in: Cell 1995 Jul 14;82(1):1-4. *Cell* 82(1): 77-87
- Baruch D, Gormely J, Ma C, Howard R and Pasloske B, (1996), *Plasmodium falciparum* erythrocyte membrane protein 1 is a parasitized erythrocyte receptor for adherence to CD36, thrombospondin, and intercellular adhesion molecule 1. *Proc. Natl. Acad. Sci. USA.* 93(8): 3497-502
- Baruch DI, Ma XC, Singh HB, Bi X, Pasloske BL, *et al.*, (1997), Identification of a region of PfEMP1 that mediates adherence of *Plasmodium falciparum* infected erythrocytes to CD36: conserved function with variant sequence. *Blood* 90(9): 3766-75.
- Beck H, Felger I, Genton B, Alexander N, al-Yaman F, *et al.*, (1995a), Humoral and cell-mediated immunity to the *Plasmodium falciparum* ring-infected erythrocyte surface antigen in an adult population exposed to highly endemic malaria. *Infect. Immun.* 1995 Feb; 63(2): 596-600
- Beck HP, Felger I, Barker M, Bugawan T, Genton B, *et al.*, (1995b), Evidence of HLA class II association with antibody response against the malaria vaccine SPF66 in a naturally exposed population. *Am. J. Trop. Med. Hyg.* 53(3): 284-8.
- Beier JC, Killeen GF and Githure JJ, (1999), Short report: entomologic inoculation rates and *Plasmodium falciparum* malaria prevalence in Africa. *Am. J. Trop. Med. Hyg.* 61(1): 109-13.
- Bellamy R, Kwiatkowski D and Hill AV, (1998), Absence of an association between intercellular adhesion molecule 1, complement receptor 1 and interleukin 1 receptor antagonist gene polymorphisms and severe malaria in a West African population. *Trans. Roy. Soc. Trop. Med. Hyg.* 92(3): 312-6.

- Berendt A, Simmons D, Tansey J, Newbold C and Marsh K, (1989), Intercellular adhesion molecule-1 is an endothelial cell adhesion receptor for *Plasmodium falciparum*. *Nature* 341(6237): 57-9
- Berendt A, Ferguson D, Gardner J, Turner G, Rowe A, *et al.*, (1994a), Molecular mechanism of sequestration in malaria. *Parasitology* 108(S19-S28)
- Berendt A, Turner G and Newbold C, (1994b), Cerebral malaria: The sequestration hypothesis. *Parasitol Today* 10(10): 412 - 414
- Berzins K, Perlmann H, Wahlin B, Ekre HP, Hogh B, *et al.*, (1991), Passive immunization of Aotus monkeys with human antibodies to the *Plasmodium falciparum* antigen Pfl55/RESA. *Infect. Immun.* 59(4): 1500-6.
- Biemba G, Gordeuk VR, Thuma P and Weiss G, (2000), Markers of inflammation in children with severe malarial anaemia. *Trop. Med. Int. Health.* 5(4): 256-62.
- Bienzle U, Ayeni O, Lucas AO and Luzzatto L, (1972), Glucose-6-phosphate dehydrogenase and malaria. Greater resistance of females heterozygous for enzyme deficiency and of males with non-deficient variant. *Lancet* 1(7742): 107-10.
- Biggs BA, Kemp DJ and Brown GV, (1989), Subtelomeric chromosome deletions in field isolates of *Plasmodium falciparum* and their relationship to loss of cytoadherence *in vitro*. *Proc. Natl. Acad. Sci. USA* 86(7): 2428-32.
- Biggs BA, Gooze L, Wycherley K, Wilkinson D, Boyd AW, *et al.*, (1990), Knob-independent cytoadherence of *Plasmodium falciparum* to the leukocyte differentiation antigen CD36. *J. Exp. Med.* 171(6): 1883-92.
- Bloland PB, Boriga DA, Ruebush TK, McCormick JB, Roberts JM, *et al.*, (1999), Longitudinal cohort study of the epidemiology of malaria infections in an area of intense malaria transmission II. Descriptive epidemiology of malaria infection and disease among children. *Am. J. Trop. Med. Hyg.* 60(4): 641-8.
- Borst P, Bitter W, McCulloch R, Van-Leeuwen F and Rudenko G, (1995), Antigenic variation in malaria. *Cell* 82: 1-4
- Bottius E, BenMohamed L, Brahimi K, Gras H, Lepers JP, *et al.*, (1996), A novel *Plasmodium falciparum* sporozoite and liver stage antigen (SALSA) defines major B, T helper, and CTL epitopes. *J. Immunol* 156(8): 2874-84.
- Bouharoun Tayoun H and Druilhe P, (1992), Antibodies in *falciparum* malaria: what matters most, quantity or quality? *Mem. Inst. Oswaldo. Cruz.* 87 Suppl 3: 229-34
- Bouharoun-Tayoun H, Attanath P, Sabchareon A, Chongsuphajaisiddhi T and Druilhe P, (1990), Antibodies that protect humans against *Plasmodium falciparum* blood stages do not on their own inhibit parasite growth and invasion *in vitro*, but act in cooperation with monocytes. *J. Exp. Med.* 172(6): 1633-41.
- Bourke PF, Holt DC, Sutherland CJ, Currie B and Kemp DJ, (1996), Positional cloning of a sequence from the breakpoint of chromosome 9 commonly associated with the loss of cytoadherence. *Ann. Trop. Med. Parasitol.* 90(4): 353-7.
- Bowman S, Lawson D, Basham D, Brown D, Chillingworth T, *et al.*, (1999), The complete nucleotide sequence of chromosome 3 of *Plasmodium falciparum*. *Nature* 400(6744): 532-8.
- Branch O, Udhayakumar V, Hightower A, Oloo A, Hawley W, *et al.*, (1998), A longitudinal investigation of IgG and IgM antibody responses to the merozoite surface protein-1 19-kiloDalton domain of *Plasmodium falciparum* in pregnant women and infants: associations with febrile illness, parasitemia, and anemia. *Am. J. Trop. Med. Hyg.* 58(2): 211-9
- Brandts CH, Ndjave M, Graninger W and Kremsner PG, (1997), Effects of paracetamol on parasite clearance time in *Plasmodium falciparum* malaria. *Lancet* 350: 704-709

- Brannan L, Turner C and Phillips R, (1994), Malaria parasites undergo antigenic variation at high rates *in vivo*. *Proc. Roy. Soc. Lond. B. Biol. Sci.* 256(1345): 71-5
- Bray RS and Sinden RE, (1979), The sequestration of *Plasmodium falciparum* infected erythrocytes in the placenta. *Trans. Roy. Soc. Trop. Med. Hyg.* 73(6): 716-9
- Brewster DR, Kwiatkowski D and White NJ, (1990), Neurological sequelae of cerebral malaria in children. *Lancet* 336(8722): 1039-43.
- Brown H, Hien TT, Day N, Mai NT, Chuong LV, *et al.*, (1999), Evidence of blood-brain barrier dysfunction in human cerebral malaria. *Neuropathol. Appl. Neurobiol.* 25(4): 331-40.
- Brown IN, Brown KN and Hills LA, (1968), Immunity to malaria: the antibody response to antigenic variation by *Plasmodium knowlesi*. *Immunology* 14(1): 127-38.
- Brown J and Smalley ME, (1980), Specific antibody-dependent cellular cytotoxicity in human malaria. *Clin. Exp. Immunol.* 41(3): 423-9.
- Brown KN and Hills LA, (1971), Macrophage "activation" and the action of opsonizing antibodies in malaria. *Trans. Roy. Soc. Trop. Med. Hyg.* 65(1): 6
- Buffet PA, Gamain B, Scheidig C, Baruch D, Smith JD, *et al.*, (1999), *Plasmodium falciparum* domain mediating adhesion to chondroitin sulfate A: a receptor for human placental infection. *Proc. Natl. Acad. Sci. USA* 96(22): 12743-8.
- Bull P, Lowe B, Kortok M and Marsh K, (1999), Antibody recognition of *Plasmodium falciparum* Erythrocyte Surface Antigen in Kenya: Evidence for rare and prevalent variants. *Infect. Immun.* 67(2):
- Bull PC, Lowe BS, Kortok M, Molyneux CS, Newbold CI, *et al.*, (1998), Parasite antigens on the infected red cell surface are targets for naturally acquired immunity to malaria. *Nat. Med.* 4(3): 358-60
- Bull PC, Kortok M, Kai O, Ndungu F, Ross A, *et al.*, (2000), *Plasmodium falciparum*-infected erythrocytes: agglutination by diverse Kenyan plasma is associated with severe disease and young host age. *J. Infect. Dis.* 182(1): 252-9.
- Butcher G, (1992), HIV and malaria: A lesson in immunology. *Parasitol. Today* 8(9): 311
- Butcher GA and Cohen S, (1972), Antigenic variation and protective immunity in *Plasmodium knowlesi* malaria. *Immunology* 23(4): 503-21.
- Carlson J, Helmby H, Hill A, Brewster D, Greenwood B, *et al.*, (1990), Human cerebral malaria: association with erythrocyte rosetting and lack of anti-rosetting antibodies. *Lancet* 336(8729): 1457-60
- Carlson J, Nash G, Gabutti V, al Yaman F and Wahlgren M, (1994), Natural protection against severe *Plasmodium falciparum* malaria due to impaired rosette formation. *Blood* 84(11): 3909-14
- Carter R, Schofield L and Mendis K, (1992), HLA effect in malaria: Increased Parasite-killing immunity or reduced immunopathology? *Parasitol. Today* 8(2):41-42
- Chaiyaroj SC, Angkasekwinai P, Buranakiti A, Looreesuwan S, Rogerson SJ, *et al.*, (1996), Cytoadherence characteristics of *Plasmodium falciparum* isolates from Thailand: evidence for chondroitin sulfate a as a cytoadherence receptor. *Am. J. Trop. Med. Hyg.* 55(1): 76-80.
- Chandramohan D and Greenwood BM, (1998), Is there an interaction between human immunodeficiency virus and *Plasmodium falciparum*? *Int. J. Epidemiol.* 27(2): 296-301.
- Chen Q, Heddini A, Barragan A, Fernandez V, Pearce SF, *et al.*, (2000), The semiconserved head structure of *Plasmodium falciparum* erythrocyte membrane protein 1 mediates binding to multiple independent host receptors. *J. Exp. Med.* 192(1): 1-10.

- Chen QJ, Fernandez V, Sundstrom A, Schlichtherle M, Datta S, *et al.*, (1998b), Developmental selection of var gene expression in *Plasmodium falciparum*. *Nature* 394(6691): 392-395
- Cheng Q, Cloonan N, Fischer K, Thompson J, Waine G, *et al.*, (1998), *stevor* and *rif* are *Plasmodium falciparum* multicopy gene families which potentially encode variant antigens. *Mol. Biochem. Parasitol.* 97(1-2): 161-76.
- Chizzolini C, Grau GE, Geinoz A and Schrijvers D, (1990), T lymphocyte interferon-gamma production induced by *Plasmodium falciparum* antigen is high in recently infected non-immune and low in immune subjects. *Clin. Exp. Immunol.* 79(1): 95-9.
- Chougnet C, Deloron P, Lepers JP, Tallet S, Rason MD, *et al.*, (1990), Humoral and cell-mediated immune responses to the *Plasmodium falciparum* antigens PF155/RESA and CS protein: seasonal variations in a population recently reexposed to endemic malaria. *Am. J. Trop. Med. Hyg.* 43(3): 234-42.
- Clark I and Chaudhri G, (1988), Tumour necrosis factor may contribute to the anaemia of malaria by causing dyserythropoiesis and erythrophagocytosis. *Br. J. Haematol.* 70(1): 99-103
- Clark I and Cowden W, (1999), Why is the pathology of *falciparum* worse than that of vivax malaria. *Parasitol. Today* 15(11):
- Clark IA and Rockett KA, (1994), The cytokine theory of human cerebral malaria. *Parasitol Today* 10(10): 410-412
- Clerici M and Shearer GM, (1994), The Th1-Th2 hypothesis of HIV infection: new insights. *Immunol Today* 15(12): 575-81.
- Clyde DF, (1975), Immunization of man against *falciparum* and vivax malaria by use of attenuated sporozoites. *Am. J. Trop. Med. Hyg.* 24(3): 397-401.
- Cohen S, McGregor I and S C, (1961), Gama-Globulin and acquired immunity to huma malaria. *Nature* 192 735-737
- Collins W, Pye D, Crewther P, Vandenberg K, Galland G, *et al.*, (1994), Protective immunity induced in squirrel monkeys with recombinant apical membrane antigen-1 of *Plasmodium fragile*. *Am. J. Trop. Med. Hyg.* 51(6): 711-9
- Collins WE, Anders RF, Pappaioanou M, Campbell GH, Brown GV, *et al.*, (1986), Immunization of Aotus monkeys with recombinant proteins of an erythrocyte surface antigen of *Plasmodium falciparum*. *Nature* 323(6085): 259-62.
- Collins WE, Pappaioanou M, Anders RF, Campbell GH, Brown GV, *et al.*, (1988), Immunization trials with the ring-infected erythrocyte surface antigen of *Plasmodium falciparum* in owl monkeys (*Aotus vociferans*). *Am. J. Trop. Med. Hyg.* 38(2): 268-82.
- Collins WE and Jeffery GM, (1999a), A retrospective examination of secondary sporozoite- and trophozoite-induced infections with *Plasmodium falciparum*: development of parasitologic and clinical immunity following secondary infection. *Am. J. Trop. Med. Hyg.* 61(1 Suppl): 20-35.
- Collins WE and Jeffery GM, (1999b), A retrospective examination of sporozoite- and trophozoite-induced infections with *Plasmodium falciparum*: development of parasitologic and clinical immunity during primary infection. *Am. J. Trop. Med. Hyg.* 61(1 Suppl): 4-19.
- Contamin H, Behr C, Mercereau-Puijalon O and Michel J, (2000), *Plasmodium falciparum* in the squirrel monkey (*Saimiri sciureus*): infection of non-splenectomised animals as a model for exploring clinical manifestations of malaria. *Microbes Infect.* 2(8): 945-54.
- Conway DJ, Cavanagh DR, Tanabe K, Roper C, Mikes ZS, *et al.*, (2000), A principal target of human immunity to malaria identified by molecular population genetic and immunological analyses. *Nat. Med.* 6(6): 689-92.

Cooke BM, Berendt AR, Craig AG, MacGregor J, Newbold CI, *et al.*, (1994), Rolling and stationary cytoadhesion of red blood cells parasitized by *Plasmodium falciparum*: separate roles for ICAM-1, CD36 and thrombospondin. *Br. J. Haematol.* **87(1)**: 162-70.

Cooke BM, Wahlgren M and Coppel RL, (2000), *Falciparum* malaria: Sticking up, standing out and outstanding. *Parasitol. Today* **16(10)**: 416-420

Cooper JA, (1993), Merozoite Surface Antigen-1 of *Plasmodium*. *Parasitol. Today* **9(2)**: 50 - 54

Coppel RL, Brown GV and Nussenzweig V, (1998), Adhesive proteins of the malaria parasite. *Curr. Opin. Microbiol.* **1(4)**: 472-81.

Cowman AF, Baldi DL, Healer J, Mills KE, O'Donnell RA, *et al.*, (2000), Functional analysis of proteins involved in *Plasmodium falciparum* merozoite invasion of red blood cells. *FEBS Lett.* **476(1-2)**: 84-8.

Crabb B, Cooke B, Reeder J, Waller R, Caruana S, *et al.*, (1997), Targeted gene disruption shows that knobs enable malaria-infected red cells to cytoadhere under physiological shear stress. *Cell* **89(2)**: 287-96

Craig AG and Berendt AR, (1991), The role of ICAM-1 as a receptor for rhinovirus and malaria. *Chem. Immunol.* **50(116-34)**

Crandall I, Land KM and Sherman IW, (1994), *Plasmodium falciparum*: pfallhesin and CD36 form an adhesin/receptor pair that is responsible for the pH-dependent portion of cytoadherence/sequestration. *Exp. Parasitol.* **78(2)**: 203-9.

Crawley J, Smith S, Kirkham F, Muthinji P, Waruiru C, *et al.*, (1996), Seizures and status epilepticus in childhood cerebral malaria. *Q. J. Med.* **89(8)**: 591-7.

Cross GA, Wirtz LE and Navarro M, (1998), Regulation of vsg expression site transcription and switching in *Trypanosoma brucei*. *Mol. Biochem. Parasitol.* **91(1)**: 77-91.

Daly TM and Long CA, (1993), A recombinant 15-kilodalton carboxyl-terminal fragment of *Plasmodium yoelii yoelii* 17XL merozoite surface protein 1 induces a protective immune response in mice. *Infect. Immun.* **61(6)**: 2462-7.

Dame JB, Williams JL, McCutchan TF, Weber JL, Wirtz RA, *et al.*, (1984), Structure of the gene encoding the immunodominant surface antigen on the sporozoite of the human malaria parasite *Plasmodium falciparum*. *Science* **225(4662)**: 593-9.

David PH, Hommel M, Miller LH, Udeinya IJ and Oligino LD, (1983), Parasite sequestration in *Plasmodium falciparum* malaria: spleen and antibody modulation of cytoadherence of infected erythrocytes. *Proc. Natl. Acad. Sci. USA* **80(16)**: 5075-9.

Davis TM, Krishna S, Looareesuwan S, Supanaranond W, Pukrittayakamee S, *et al.*, (1990), Erythrocyte sequestration and anemia in severe *falciparum* malaria. Analysis of acute changes in venous hematocrit using a simple mathematical model. *J. Clin. Invest.* **86(3)**: 793-800.

Davis TM, Supanaranond W, Pukrittayakamee S, Crawley JC, Villaiwanna N, *et al.*, (1995), The effect of plasma free fatty acids and long-chain triglycerides on glucose metabolism in uncomplicated *falciparum* malaria. *Trans. Roy. Soc. Trop. Med. Hyg.* **89(5)**: 511-5.

Day K and Marsh K, (1991), Naturally acquired immunity to *Plasmodium falciparum*. *Immunol. Today* **A68 - A71**

Day K, Karamalis F, Thompson J, Barnes D, Peterson C, *et al.*, (1993), Genes necessary for expression of a virulence determinant and for transmission of *Plasmodium falciparum* are located on a 0.3-megabase region of chromosome 9. *Proc. Natl. Acad. Sci. USA.* **90(17)**: 8292-6

Deans JA, Alderson T, Thomas AW, Mitchell GH, Lennox ES, *et al.*, (1982), Rat monoclonal antibodies which inhibit the *in vitro* multiplication of *Plasmodium knowlesi*. *Clin. Exp. Immunol.* **49(2)**: 297-309.

Deans JA, Knight AM, Jean WC, Waters AP, Cohen S, *et al.*, (1988), Vaccination trials in rhesus monkeys with a minor, invariant, *Plasmodium knowlesi* 66 kD merozoite antigen. *Parasite Immunol* 10(5): 535-52.

Deutsch KW, del Pinal A and Wellems TE, (1999), Intra-cluster recombination and var transcription switches in the antigenic variation of *Plasmodium falciparum*. *Mol. Biochem. Parasitol.* 101(1-2): 107-16.

Dekker E, Hellerstein MK, Romijn JA, Neese RA, Peshu N, *et al.*, (1997a), Glucose homeostasis in children with *falciparum* malaria: precursor supply limits gluconeogenesis and glucose production. *J. Clin. Endocrinol. Metab.* 82(8): 2514-21.

Dekker E, Romijn JA, Moeniralam HS, Waruiru C, Ackermans MT, *et al.*, (1997b), The influence of alanine infusion on glucose production in 'malnourished' African children with *falciparum* malaria. *Q. J. Med.* 90(7): 455-60.

Deloron P and Chougnet C, (1992), Is immunity to malaria really short lived. *Parasitol. Today* 8(11): 375-378

Di Perri G, Solbiati M, Vento S, De Checchi G, Luzzati R, *et al.*, (1994), West African Immigrants and New Patterns of Malaria Imported to North Eastern Italy. *J. Travel. Med.* 1(3): 147-151.

Di Perri G, Bonora S, Vento S and Concia E, (1995), Acquired immunity to *Plasmodium falciparum*. *Parasitol Today* 11(9): 346-347

Dietz K, Molineaux L and Thomas A, (1974), A malaria model tested in the African Savannah. *Bull. World. Health. Organ.* 50(347 - 357):

Dietz K, (1988), Density-dependence in parasite transmission dynamics. *Parasitol. Today* 4(4): 91-97

Dieye A, Rogier C, Trape J-F, Sarthou J-L and Druilhe P, (1997), HLA class-1-associated resistance to severe malaria: A parasitological re-assessment. *Parasitol. Today* 13(2): 48-49

Diggs CL, Aikawa M and Haynes JD, (1977), Ultrastructure and viability of cryopreserved *Plasmodium falciparum*. *Bull. World. Health. Organ.* 55(2-3): 299-304

Dondorp AM, Angus BJ, Hardeman MR, Chotivanich KT, Silamut K, *et al.*, (1997), Prognostic significance of reduced red blood cell deformability in severe *falciparum* malaria. *Am. J. Trop. Med. Hyg.* 57(5): 507-11.

Dondorp AM, 1999, On the pathophysiology of severe *falciparum* malaria with special reference to red cell deformability. *D Phil, University of Amsterdam*

Dondorp AM, Kager PA, Vreeken J and White NJ, (2000), Abnormal blood flow and red blood cell deformability in severe malaria. *Parasitol Today* 16(6): 228-32.

Doolan DL, Sedegah M, Hedstrom RC, Hobart P, Charoenvit Y, *et al.*, (1996), Circumventing genetic restriction of protection against malaria with multigene DNA immunization: CD8+ cell-, interferon gamma-, and nitric oxide-dependent immunity. *J. Exp. Med.* 183(4): 1739-46.

Druilhe P and Khusmith S, (1987), Epidemiological correlation between levels of antibodies promoting merozoite phagocytosis of *Plasmodium falciparum* and malaria-immune status. *Infect. Immun.* 55(4): 888-91.

Druilhe P and al e, (1997), *In vivo* veritas: lessons from immunoglobulin-transfer experiments in malaria patients.

Druilhe P and Perignon J, (1997), A hypothesis about the chronicity of malaria infection. *Parasitol. Today* 13(9): 353-355

Dubois B, Deloron P, Astagneau P, Chougnet C and Lepers J, (1993), Isotypic analysis of *Plasmodium falciparum*-specific antibodies and their relation to protection in Madagascar. *Infect. Immun.* 1993 Oct; 61(10): 4498-500

Duffy PE, Craig AG and Baruch DI, (2001), Variant proteins on the surface of malaria-infected erythrocytes--developing vaccines. *Trends Parasitol.* **17(8): 354-6.**

Dye CL, JD; Curtis, CF, (1996), A test of the malaria Strain Theory. *Parasitol. Today* **12(3): 88-90**

Eaton MD, (1938), the agglutination of *Plasmodium knowlesi* by immune serum. *J. Exp. Med.* **67(857)**

Edozien J, Gilles H and Udeozo I, (1962), Adult and cord blood gammaglobulin and immunity to malaria in Nigerians. *Lancet* **2(951-955)**

Egan A, Morris J, Barnish G, Allen S, Greenwood B, *et al.*, (1996), Clinical immunity to *Plasmodium falciparum* malaria is associated with serum antibodies to the 19-kDa C-terminal fragment of the merozoite surface antigen, PfMSP-1. *J. Infect. Dis.* **173(3): 765-9**

Egan AF, Burghaus P, Druilhe P, Holder AA and Riley EM, (1999), Human antibodies to the 19kDa C-terminal fragment of *Plasmodium falciparum* merozoite surface protein 1 inhibit parasite growth *in vitro*. *Parasite Immunol* **21(3): 133-9.**

Engelbrecht F, Felger I, Genton B, Alpers M and Beck H, (1995), *Plasmodium falciparum*: malaria morbidity is associated with specific merozoite surface antigen 2 genotypes. *Exp. Parasitol.* **81(1): 90-6**

English M, Marsh V, Amukoye E, Lowe B, Murphy S, *et al.*, (1996a), Chronic salicylate poisoning and severe malaria. *Lancet* **347(1736-1737)**

English M, Punt J, Mwangi I, McHugh K and Marsh K, (1996b), Clinical overlap between malaria and severe pneumonia in African children in hospital. *Trans. Roy. Soc. Trop. Med. Hyg.* **90(658-662)**

English M, Muambi B, Mithwani S and Marsh K, (1997a), Lactic acidosis and oxygen debt in African children with severe malaria. *Q. J. Med.* **90(563-569)**

English M, Sauerwein R, Waruiru C, Mosobo M, Obiero J, *et al.*, (1997b), Acidosis in severe childhood malaria. *Q J Med.* **90(263-270): 263-270**

English M, Wale S, Binns G, Mwangi I, Sauerwein H, *et al.*, (1998), Hypoglycaemia on and after admission in Kenyan children with severe malaria. *Q. J. Med.* **91(3): 191-7.**

Erunkulu OA, Hill AV, Kwiatkowski DP, Todd JE, Iqbal J, *et al.*, (1992), Severe malaria in Gambian children is not due to lack of previous exposure to malaria. *Clin. Exp. Immunol.* **89(2): 296-300.**

Facer CA, (1980), Direct antiglobulin reactions in Gambian children with *P. falciparum* malaria. III. Expression of IgG subclass determinants and genetic markers and association with anaemia. *Clin. Exp. Immunol.* **41(1): 81-90.**

Fagan T, 1999, Structural, functional and antigenic analysis of PfEMP-1, the major variant surface antigen of *P. falciparum* infected erythrocytes. *D Phil, Oxford, Oxford*

Fandeur T, Le-Scanf, Bonnemains B, Slomianny C and Mercereau-Puijalon O, (1995), Immune pressure selects for *Plasmodium falciparum* parasites presenting distinct red blood cell surface antigens and inducing strain-specific protection in *Saimiri sciureus* monkeys. *J. Exp. Med.* **181(1): 283-95**

Favaloro JM, Coppel RL, Corcoran LM, Foote SJ, Brown GV, *et al.*, (1986), Structure of the RESA gene of *Plasmodium falciparum*. *Nucleic Acids Res.* **14(21): 8265-77.**

Fazekas de St G and Webster RG, (1966), Disquisitions of Original Antigenic Sin. I. Evidence in man. *J. Exp. Med.* **124(3): 331-45.**

Felger I, Tavul L, Kabintik S, Marshall V, Genton B, *et al.*, (1994), *Plasmodium falciparum*: extensive polymorphism in merozoite surface antigen 2 alleles in an area with endemic malaria in Papua New Guinea. *Exp. Parasitol.* **79(2): 106-16**

- Fell A and Smith N, (1998), Immunity to asexual blood stages of *Plasmodium*: Is resistance to acute malaria adaptive or innate. *Parasitol. Today* 14(9): 364-368
- Fernandez V, Hommel M, Chen Q, Hagblom P and Wahlgren M, (1999), Small, clonally variant antigens expressed on the surface of the *Plasmodium falciparum*-infected erythrocyte are encoded by the rif gene family and are the target of human immune responses. *J. Exp. Med.* 190(10): 1393-404
- Fernandez-Reyes D, Craig AG, Kyes SA, Peshu N, Snow RW, *et al.*, (1997), A high frequency African coding polymorphism in the N-terminal domain of ICAM-1 predisposing to cerebral malaria in Kenya. *Hum. Mol. Genet.* 6(8): 1357-60.
- Ferrante A and Rzepczyk C, (1997), Atypical IgG subclass antibody responses to *Plasmodium falciparum* asexual stage antigens. *Parasitol. Today* 13(4): 145 - 148
- Ferreira M, Kimura E, De S, JM and Katzin A, (1996), The isotype composition and avidity of naturally acquired anti-*Plasmodium falciparum* antibodies: differential patterns in clinically immune Africans and Amazonian patients. *Am. J. Trop. Med. Hyg.* 55(3): 315-23
- Ferrick DA, Schrenzel MD, Mulvania T, Hsieh B, Ferlin WG, *et al.*, (1995), Differential production of interferon-gamma and interleukin-4 in response to Th1- and Th2-stimulating pathogens by gamma delta T cells *in vivo*. *Nature* 373(6511): 255-7.
- Fidock D, Pasquetto V, Gras H, Badell E, Eling W, *et al.*, (1997), *Plasmodium falciparum* sporozoite invasion is inhibited by naturally acquired or experimentally induced polyclonal antibodies to the STARP antigen. *Eur. J. Immunol.* 1997 Oct; 27(10): 2502-13
- Flyg BW, Perlmann H, Perlmann P, Esposito F and Berzins K, (1997), Wild isolates of *Plasmodium falciparum* malaria show decreased sensitivity to *in vitro* inhibition of parasite growth mediated by autologous host antibodies. *Clin. Exp. Immunol.* 107(2): 321-7.
- Fontenille D and Lochouart L, (1999), The complexity of the malaria vectorial system in Africa. *Parassitologia* 41(1-3): 267-71.
- Forsyth K, Philip G, Smith T, Kum E, Southwell B, *et al.*, (1989), Diversity of antigens expressed on the surface of erythrocytes infected with mature *Plasmodium falciparum* parasites in Papua New Guinea. *Am. J. Trop. Med. Hyg.* 41(3): 259-65
- Fried, Nosten, Brockman, Brabin and Duffy, (1998), Maternal antibodies block malaria. *Nature* 395(6705): 852-2
- Fried M and Duffy PE, (1996), Adherence of *Plasmodium falciparum* to chondroitin sulfate A in the human placenta. *Science* 272(5267): 1502-4.
- Friedman MJ, (1978), Erythrocytic mechanism of sickle cell resistance to malaria. *Proc. Natl. Acad. Sci. USA* 75(4): 1994-7.
- Friedman MJ, (1979), Oxidant damage mediates variant red cell resistance to malaria. *Nature* 280(5719): 245-7.
- Fruh K, Doumbo O, Muller HM, Koita O, McBride J, *et al.*, (1991), Human antibody response to the major merozoite surface antigen of *Plasmodium falciparum* is strain specific and short-lived. *Infect. Immun.* 59(4): 1319-24.
- Garcia A, Cot M, Chippaux JP, Ranque S, Feingold J, *et al.*, (1998), Genetic control of blood infection levels in human malaria: evidence for a complex genetic model. *Am. J. Trop. Med. Hyg.* 58(4): 480-8.
- Gardiner DL, Holt DC, Thomas EA, Kemp DJ and Trenholme KR, (2000), Inhibition of *Plasmodium falciparum* clag9 gene function by antisense RNA. *Mol. Biochem. Parasitol.* 110(1): 33-41.
- Gardner JP, Pinches RA, Roberts DJ and Newbold CI, (1996), Variant antigens and endothelial receptor adhesion in *Plasmodium falciparum*. *Proc. Natl. Acad. Sci. USA* 93(8): 3503-8.

- Gardner MJ, Tettelin H, Carucci DJ, Cummings LM, Smith HO, *et al.*, (1999), The malaria genome sequencing project: complete sequence of *Plasmodium falciparum* chromosome 2. *Parassitologia* 41(1-3): 69-75.
- Giha HA, Theander TG, Staalso T, Roper C, Elhassan IM, *et al.*, (1998), Seasonal variation in agglutination of *Plasmodium falciparum*-infected erythrocytes. *Am. J. Trop. Med. Hyg.* 58(4): 399-405
- Giha HA, Staalsoe T, Dodoo D, Elhassan IM, Roper C, *et al.*, (1999), Overlapping antigenic repertoires of variant antigens expressed on the surface of erythrocytes infected by *Plasmodium falciparum*. *Parasitology* 119(Pt 1): 7-17
- Giha HA, Staalsoe T, Dodoo D, Roper C, Satti GM, *et al.*, (2000), Antibodies to variable *Plasmodium falciparum*-infected erythrocyte surface antigens are associated with protection from novel malaria infections. *Immunol. Lett.* 71(2): 117-26.
- Gilbert SC, Plebanski M, Harris SJ, Allsopp CE, Thomas R, *et al.*, (1997), A protein particle vaccine containing multiple malaria epitopes. *Nat. Biotechnol.* 15(12): 1280-4.
- Gilbert SC, Plebanski M, Gupta S, Morris J, Cox M, *et al.*, (1998), Association of malaria parasite population structure, HLA, and immunological antagonism. *Science* 279(5354): 1173-7.
- Gilbert SC, Schneider J, Plebanski M, Hannan CM, Blanchard TJ, *et al.*, (1999), Ty virus-like particles, DNA vaccines and Modified Vaccinia Virus Ankara; comparisons and combinations. *Biol. Chem.* 380(3): 299-303.
- Gilks C, Walliker D and Newbold C, (1990), Relationships between sequestration, antigenic variation and chronic parasitism in *Plasmodium chabaudi chabaudi*--a rodent malaria model. *Parasite. Immunol.* 1990 Jan; 12(1): 45-64
- Golenser J and Chevion M, (1989), Oxidant stress and malaria: host-parasite interrelationships in normal and abnormal erythrocytes. *Semin. Hematol.* 26(4): 313-25.
- Good M, (1994a), Antigenic diversity and MHC genetics in sporozoite immunity. *Immunol. Lett.* 1994 Jul; 41(2-3): 95-8
- Good M, (1994b), Immunological responses from non-exposed donors to malaria antigens: implications for immunity and pathology. *Immunol. Lett.* 41(2-3): 123-5
- Good MF, Zevering Y, Currier J and Bilsborough J, (1993), 'Original antigenic sin', T cell memory, and malaria sporozoite immunity: an hypothesis for immune evasion. *Parasite Immunol* 15(4): 187-93.
- Good MF, (1995), Development of immunity to malaria may not be an entirely active process. *Parasite Immunol* 17(2): 55-9.
- Goodier M, Fey P, Eichmann K and Langhorne J, (1992), Human peripheral blood gamma delta T cells respond to antigens of *Plasmodium falciparum*. *Int. Immunol.* 4(1): 33-41.
- Grau G, Piguet P, Vassalli P and Lambert P, (1989a), Tumor-necrosis factor and other cytokines in cerebral malaria: Experimental and clinical data. *Immunol. Rev.* 112(49-70
- Grau G, Taylor T, Molyneux M, Wirima J, Vassalli P, *et al.*, (1989b), Tumor necrosis factor and disease severity in children with *falciparum* malaria. *N. Eng. J. Med.* 320(24): 1586-1591
- Grau G and De-Kossodo S, (1994), Cerebral Malaria: Mediator, Mechanical obstruction or more? *Parasitol. Today* 10(10): 408-414
- Graves P, Bhatia K, Burkot T, Prasad M, Wirtz R, *et al.*, (1989), Association between HLA type and antibody response to malaria sporozoite and gametocyte epitopes is not evident in immune Papua New Guineans. *Clin-Exp-Immunol.* 1989 Dec; 78(3): 418-23

- Greenberg A, Ntumbanzondo M, Ntula NM, L, Howell J and Davachi F, (1989), Hospital-based surveillance of malaria-related paediatric morbidity and mortality in Kinshasa, Zaire. *Bull. World. Health. Organ.* 1989; 67(2): 189-96
- Greenwood B, Marsh K and Snow R, (1991), Why do some African children develop severe malaria. *Parasitol Today* 7(10): 277-281
- Greenwood BM, Stratton D, Williamson WA and Mohammed I, (1978), A study of the role of immunological factors in the pathogenesis of the anaemia of acute malaria. *Trans. Roy. Soc. Trop. Med. Hyg.* 72(4): 378-85
- Groux H and Gysin J, (1990), Opsonization as an effector mechanism in human protection against asexual blood stages of *Plasmodium falciparum*: functional role of IgG subclasses. *Res. Immunol.* 141(6): 529-42
- Groux H, Perraut R, Garraud O, Poingt JP and Gysin J, (1990), Functional characterization of the antibody-mediated protection against blood stages of *Plasmodium falciparum* in the monkey *Saimiri sciureus*. *Eur J. Immunol* 20(10): 2317-23.
- Gupta S and Day KP, (1994), A strain theory of malaria transmission. *Parasitol Today* 10(12): 476 - 481
- Gupta S, Trenholme K, Anderson RM and Day KP, (1994), Antigenic diversity and the transmission dynamics of *Plasmodium falciparum*. *Science* 263(5149): 961-3.
- Gupta S and Anderson RM, (1999), Population structure of pathogens: The role of immune selection. *Parasitol Today* 15(12): 497 - 500
- Gupta S, Snow RW, Donnelly C and Newbold C, (1999a), Acquired immunity and postnatal clinical protection in childhood cerebral malaria. *Proc. R. Soc. Lond. B. Biol. Sci.* 266(1414): 33-8.
- Gupta S, Snow RW, Donnelly CA, Marsh K and Newbold C, (1999b), Immunity to non-cerebral severe malaria is acquired after one or two infections. *Nat. Med.* 5(3): 340-3.
- Hamad AA, El Hassan IM, El Khalifa AA, Ahmed GI, Abdelrahim SA, *et al.*, (2000), Chronic *Plasmodium falciparum* infections in an area of low intensity malaria transmission in the Sudan. *Parasitology* 120(Pt 5): 447-56.
- Hay SI, Rogers DJ, Toomer JF and Snow RW, (2000), Annual *Plasmodium falciparum* entomological inoculation rates (EIR) across Africa: literature survey, Internet access and review. *Trans. Roy. Soc. Trop. Med. Hyg.* 94(2): 113-27.
- Hay SI, Rogers DJ, Shanks GD, Myers MF and Snow RW, (2001), Malaria early warning in Kenya. *Trends Parasitol.* 17(2): 95-9.
- Hayward RE, Tiwari B, Piper KP, Baruch DI and Day KP, (1999), Virulence and transmission success of the malarial parasite *Plasmodium falciparum*. *Proc. Natl. Acad. Sci. USA* 96(8): 4563-8.
- Helmby H, Cavelier L, Pettersson U and Wahlgren M, (1993), Rosetting *Plasmodium falciparum*-infected erythrocytes express unique strain-specific antigens on their surface. *Infect. Immun.* 61(1): 284-8.
- Henquin JC, Horemans B, Nenquin M, Verniers J and Lambert AE, (1975), Quinine-induced modifications of insulin release and glucose metabolism by isolated pancreatic islets. *FEBS Lett.* 57(3): 280-4.
- Hill A, Elvin J, Willis A, Aidoo M, Allsopp C, *et al.*, (1992), Molecular analysis of the association of HLA-B53 and resistance to severe malaria [see comments] CM: Comment in: *Nature* 1992 Dec 3;360(6403):417-8. *Nature.* 1992 Dec 3; 360(6403): 434-9
- Hill AV, Allsopp CE, Kwiatkowski D, Anstey NM, Twumasi P, *et al.*, (1991), Common west African HLA antigens are associated with protection from severe malaria. *Nature* 352(6336): 595-600.
- Hill AV, Yates SN, Allsopp CE, Gupta S, Gilbert SC, *et al.*, (1994), Human leukocyte antigens and natural selection by malaria. *Philos. Trans. R. Soc. Lond. B. Biol. Sci.* 346(1317): 379-85.

- Hill AV, (1997), Genetic susceptibility to multifactorial diseases. *Trans. Roy. Soc. Trop. Med. Hyg.* 91(4): 369-71.
- Hill W and Babiker H, (1995), Estimation of numbers of malaria clones in blood samples. *Proc. R. Soc. Lond. B. Biol. Sci.* 1995 Dec 22; 262(1365): 249-57
- Hirunpetcharat C, Finkelman F, Clark IA and Good MF, (1999), Malaria parasite-specific Th1-like T cells simultaneously reduce parasitemia and promote disease. *Parasite Immunol* 21(6): 319-29.
- Ho M, Webster HK, Tongtawe P, Pattanapanyasat K and Weidanz WP, (1990a), Increased gamma delta T cells in acute *Plasmodium falciparum* malaria. *Immunol. Lett.* 25(1-3): 139-41.
- Ho M, White NJ, Looareesuwan S, Wattanagoon Y, Lee SH, *et al.*, (1990b), Splenic Fc receptor function in host defense and anemia in acute *Plasmodium falciparum* malaria. *J. Infect. Dis.* 161(3): 555-61.
- Ho M, Singh B, Looareesuwan S, Davis TM, Bunnag D, *et al.*, (1991), Clinical correlates of *in vitro* *Plasmodium falciparum* cytoadherence. *Infect. Immun.* 59(3): 873-8.
- Hoffman S, Oster C, Plowe C, Woollett G, Beier J, *et al.*, (1987), Naturally acquired antibodies to sporozoites do not prevent malaria: vaccine development implications. *Science* 237(4815): 639-42
- Hoffman S and Franke E, (1994), Inducing protective immune responses against the sporozoite and liver stages of *Plasmodium*. *Immunol. Lett.* 41(2-3): 89-94
- Hogh B, Marbiah N, Burghaus P and Andersen P, (1995), Relationship between maternally derived anti-*Plasmodium falciparum* antibodies and risk of infection and disease in infants living in an area of Liberia, west Africa, in which malaria is highly endemic. *Infect. Immun.* 1995 Oct; 63(10): 4034-8
- Holder A, (1994), what is the function of MSP-1 on the malaria merozoite. *Parasitol. Today* 10(5): 182-184
- Hughes M and Hughes A, (1995), Natural selection on *Plasmodium* surface proteins. *Mol. Biochem. Parasitol.* 1995 Apr; 71(1): 99-113
- Iqbal J, Perlmann P and Berzins K, (1993), Serological diversity of antigens expressed on the surface of erythrocytes infected with *Plasmodium falciparum*. *Trans. Roy. Soc. Trop. Med. Hyg.* 1993 Sep-Oct; 87(5): 583-8
- Jadin J, Timperman G and De Ruysser F, (1976), Physiological and morphological characters in two pyrimethamine- resistant lines of *Plasmodium berghei* SP11 after cryopreservation. *Trans. Roy. Soc. Trop. Med. Hyg.* 70(3): 235-7
- Jaffar S, Van-Hensbroek M, Palmer A, Schneider G and Greenwood B, (1997), Predictors of a fatal outcome following childhood cerebral malaria. *Am. J. Trop. Med. Hyg.* 57(1): 20-4
- Jakobsen PH, Kurtzhals JA, Riley EM, Hviid L, Theander TG, *et al.*, (1997), Antibody responses to Rhoptry-Associated Protein-1 (RAP-1) of *Plasmodium falciparum* parasites in humans from areas of different malaria endemicity. *Parasite Immunol* 19(9): 387-93.
- Jeffery GM, (1966), Epidemiological significance of repeated infections with homologous and heterologous strains and species of *Plasmodium*. *Bull. World. Health. Organ.* 35(6): 873-82
- Johnson A, Leke R, Harun L, Ginsberg C, Ngogang J, *et al.*, (2000), Interaction of HLA and age on levels of antibody to *Plasmodium falciparum* rhoptry-associated proteins 1 and 2. *Infect. Immun.* 68(4): 2231-6.
- Kagi D, Vignaux F, Ledermann B, Burki K, Depraetere V, *et al.*, (1994), Fas and perforin pathways as major mechanisms of T cell-mediated cytotoxicity. *Science* 265(5171): 528-30.
- Kampfl A, Pfausler B, Haring H, Denchev D, Donnemiller E, *et al.*, (1997), Impaired microcirculation and tissue oxygenation in human cerebral malaria: a single photon emission computed tomography and near-infrared spectroscopy study. *Am. J. Trop. Med. Hyg.* 56(6): 585-7

- Karunaweera N, Carter R, Grau G and Mendis K, (1998), Demonstration of anti-disease immunity to *Plasmodium vivax* malaria in Sri Lanka using a quantitative method to assess clinical disease. *Am. J. Trop. Med. Hyg.* 58(2): 204-10
- Kaul DK, Liu XD, Nagel RL and Shear HL, (1998), Microvascular hemodynamics and *in vivo* evidence for the role of intercellular adhesion molecule-1 in the sequestration of infected red blood cells in a mouse model of lethal malaria. *Am. J. Trop. Med. Hyg.* 58(2): 240-7.
- Kemeny DM, Noble A, Holmes BJ and Diaz-Sanchez D, (1994), Immune regulation: a new role for the CD8+ T cell. *Immunol Today* 15(3): 107-10.
- Kemp D, Thompson J, Barnes D, Triglia T, Karamalis F, *et al.*, (1992), A chromosome 9 deletion in *Plasmodium falciparum* results in loss of cytoadherence. *Mem. Inst. Oswaldo. Cruz.* 1992; 87 Suppl 3: 85-9
- Kern P, Hemmer CJ, Van Damme J, Gruss HJ and Dietrich M, (1989), Elevated tumor necrosis factor alpha and interleukin-6 serum levels as markers for complicated *Plasmodium falciparum* malaria. *Am J Med* 87(2): 139-43.
- Kilejian A, (1979), Characterization of a protein correlated with the production of knob-like protrusions on membranes of erythrocytes infected with *Plasmodium falciparum*. *Proc. Natl. Acad. Sci. USA* 76(9): 4650-3.
- Kohler H, Muller S and Nara P, (1994), Deceptive imprinting in the immune response against HIV-1. *immunol. Today* 15(10): 475-478
- Kremsner PG, Winkler S, Wildling E, Prada J, Bienzle U, *et al.*, (1996), High plasma levels of nitrogen oxides are associated with severe disease and correlate with rapid parasitological and clinical cure in *Plasmodium falciparum* malaria. *Trans. Roy. Soc. Trop. Med. Hyg.* 90(1): 44-7.
- Krishna S, Waller DW, ter Kuile F, Kwiatkowski D, Crawley J, *et al.*, (1994), Lactic acidosis and hypoglycaemia in children with severe malaria: pathophysiological and prognostic significance. *Trans. Roy. Soc. Trop. Med. Hyg.* 88(1): 67-73.
- Kun JF, Mordmuller B, Lell B, Lehman LG, Luckner D, *et al.*, (1998), Polymorphism in promoter region of inducible nitric oxide synthase gene and protection against malaria. *Lancet* 351(9098): 265-6.
- Kun JF, Klabunde J, Lell B, Luckner D, Alpers M, *et al.*, (1999), Association of the ICAM-1 Kilifi mutation with protection against severe malaria in Lambarene, Gabon. *Am. J. Trop. Med. Hyg.* 61(5): 776-9.
- Kurtzhal JA, Adabayeri V, Goka BQ, Akanmori BD, Oliver-Commey JO, *et al.*, (1998), Low plasma concentrations of interleukin 10 in severe malarial anaemia compared with cerebral and uncomplicated malaria. *Lancet* 351(1768-72)
- Kwiatkowski D, Hill AV, Sambou I, Twumasi P, Castracane J, *et al.*, (1990), TNF concentration in fatal cerebral, non-fatal cerebral, and uncomplicated *Plasmodium falciparum* malaria. *Lancet* 336(8725): 1201-4.
- Kwiatkowski D, Bate C, Scragg I, Beattie P, Udalova I, *et al.*, (1997), The malarial fever response--pathogenesis, polymorphism and prospects for intervention. *Ann. Trop. Med. Parasitol.* 91(5): 533-42
- Kyes SA, Rowe JA, Kriek N and Newbold CI, (1999), Rifins: a second family of clonally variant proteins expressed on the surface of red cells infected with *Plasmodium falciparum*. *Proc. Natl. Acad. Sci. USA* 96(16): 9333-8
- Langhorne J, (1996), Gama-Delta cells in malaria infections. *Parasitol. Today* 12(5):
- Lawrence G, Cheng QQ, Reed C, Taylor D, Stowers A, *et al.*, (2000), Effect of vaccination with 3 recombinant asexual-stage malaria antigens on initial growth rates of *Plasmodium falciparum* in non-immune volunteers. *Vaccine* 18(18): 1925-31.
- Leech JH, Barnwell JW, Aikawa M, Miller LH and Howard RJ, (1984a), *Plasmodium falciparum* malaria: association of knobs on the surface of infected erythrocytes with a histidine-rich protein and the erythrocyte skeleton. *J. Cell. Biol.* 98(4): 1256-64.

- Leech JH, Barnwell JW, Miller LH and Howard RJ, (1984b), Identification of a strain-specific malarial antigen exposed on the surface of *Plasmodium falciparum*-infected erythrocytes. *J. Exp. Med.* **159(6)**: 1567-75.
- Lockyer M, Marsh K and Newbold C, (1989), Wild isolates of *Plasmodium falciparum* show extensive polymorphism in T cell epitopes of the circumsporozoite protein. *Mol. Biochem. Parasitol.* **1989 Dec**; **37(2)**: 275-80
- Looareesuwan S, Suntharasamai P, Webster HK and Ho M, (1993), Malaria in splenectomized patients: report of four cases and review. *Clin Infect Dis* **16(3)**: 361-6.
- Lowe B. (1999), Does prior exposure of Kenyan children to *Plasmodium ovale* infection confer protective cross-immunity to disease caused by *Plasmodium falciparum*?, MPhil, Liverpool
- Lowin B, Hahne M, Mattmann C and Tschopp J, (1994), Cytolytic T-cell cytotoxicity is mediated through perforin and Fas lytic pathways. *Nature* **370(6491)**: 650-2.
- Luse SA and Miller LH, (1971), *Plasmodium falciparum* malaria. Ultrastructure of parasitized erythrocytes in cardiac vessels. *Am. J. Trop. Med. Hyg.* **20(5)**: 655-60.
- Lustigman S, Anders RF, Brown GV and Coppel RL, (1990), The mature-parasite-infected erythrocyte surface antigen (MESA) of *Plasmodium falciparum* associates with the erythrocyte membrane skeletal protein, band 4.1. *Mol. Biochem. Parasitol.* **38(2)**: 261-70.
- Luty AJ, Lell B, Schmidt-Ott R, Lehman LG, Luckner D, *et al.*, (1999), Interferon-gamma responses are associated with resistance to reinfection with *Plasmodium falciparum* in young African children. *J. Infect. Dis.* **179(4)**: 980-8.
- Mbogo C, Kabiru E, Muiruri S, Nzovu J, Ouma J, *et al.*, (1993), Bloodfeeding behavior of *Anopheles gambiae s.l.* and *Anopheles funestus* in Kilifi District, Kenya. *J-Am-Mosq-Control-Assoc.* **9(2)**: 225-7
- Macdonald G, (1952), The analysis of equilibrium in malaria. *Trop. Dis. Bull.* **49(813 - 828)**
- MacPherson GG, Warrell MJ, White NJ, Looareesuwan S and Warrell DA, (1985), Human cerebral malaria. A quantitative ultrastructural analysis of parasitized erythrocyte sequestration. *Am J Pathol* **119(3)**: 385-401.
- Maegraith B and Fletcher A, (1972), The pathogenesis of mammalian malaria. *Adv Parasitol* **10(49-75)**
- Margos G, Maier WA and Seitz HM, (1992), Experiments on cryopreservation of *Plasmodium falciparum*. *Trop Med Parasitol* **43(1)**: 13-6.
- Marsh K and Howard R, (1986), Antigens induced on erythrocytes by *P. falciparum*: expression of diverse and conserved determinants. *Science* **231(4734)**: 150-3
- Marsh K, Sherwood J and Howard R, (1986), Parasite-infected-cell-agglutination and indirect immunofluorescence assays for detection of human serum antibodies bound to antigens on *Plasmodium falciparum*-infected erythrocytes. *J-Immunol-Methods.* **91(1)**: 107-15
- Marsh K, Marsh VM, Brown J, Whittle HC and Greenwood BM, (1988), *Plasmodium falciparum*: the behavior of clinical isolates in an *in vitro* model of infected red blood cell sequestration. *Exp. Parasitol.* **65(2)**: 202-8.
- Marsh K, Otoo L, Hayes R, Carson D and Greenwood B, (1989), Antibodies to blood stage antigens of *Plasmodium falciparum* in rural Gambians and their relation to protection against infection. *Trans. Roy. Soc. Trop. Med. Hyg.* **1989 May-Jun**; **83(3)**: 293-303
- Marsh K, (1992), Malaria--a neglected disease? *Parasitology.* **1992**; **104 Suppl**: S53-69
- Marsh K, Forster D, Waruiru C, Mwangi I, Winstanley M, *et al.*, (1995), Indicators of life threatening malaria in African children. *New England Journal of Medicine* **332**: 1399-1404

- Marsh K, English M and Crawley J, (1996), The pathogenesis of severe malaria in African children. *Annals of Tropical Medicine and Parasitology* 90(4): 395-402
- Marsh K and Snow R, (1997), Host-parasite interaction and morbidity in malaria endemic areas. *Philos-Trans-R-Soc-Lond-B-Biol-Sci.* 352(1359): 1385-94
- Martin S, (1994), The malaria/G6PD hypothesis revisited. *Parasitol. Today* 10(7): 251-252, 262
- Maubert B, Fievet N, Tami G, Cot M, Boudin C, *et al.*, (1999), Development of antibodies against chondroitin sulfate A-adherent *Plasmodium falciparum* in pregnant women. *Infect. Immun.* 67(10): 5367-71.
- Maubert B, Fievet N, Tami G, Boudin C and Deloron P, (2000), Cytoadherence of *Plasmodium falciparum*-infected erythrocytes in the human placenta. *Parasite Immunol* 22(4): 191-9.
- McCormick CJ, Craig A, Roberts D, Newbold CI and Berendt AR, (1997), Intercellular adhesion molecule-1 and CD36 synergize to mediate adherence of *Plasmodium falciparum*-infected erythrocytes to cultured human microvascular endothelial cells. *J. Clin. Invest.* 100(10): 2521-9.
- McGregor IA, (1963), Treatment of East African *P. falciparum* malaria with west African human globulin. *Trans. Roy. Soc. Trop. Med. Hyg.* 57(170-175)
- McGuire W, Hill AV, Allsopp CE, Greenwood BM and Kwiatkowski D, (1994), Variation in the TNF-alpha promoter region associated with susceptibility to cerebral malaria. *Nature* 371(6497): 508-10.
- McGuire W, Hill AV, Greenwood BM and Kwiatkowski D, (1996), Circulating ICAM-1 levels in *falciparum* malaria are high but unrelated to disease severity. *Trans. Roy. Soc. Trop. Med. Hyg.* 90(3): 274-6.
- McGuire W, Knight JC, Hill AV, Allsopp CE, Greenwood BM, *et al.*, (1999), Severe malarial anemia and cerebral malaria are associated with different tumor necrosis factor promoter alleles. *J. Infect. Dis.* 179(1): 287-90.
- McKenna KC, Tsuji M, Sarzotti M, Sacci JB, Witney AA, *et al.*, (2000), gammadelta T cells are a component of early immunity against preerythrocytic malaria parasites. *Infect. Immun.* 68(4): 2224-30.
- McKenzie F, (2000), Why model malaria. *Parasitology today* 16(12): 511-516
- Mendis K and Carter R, (1995), Clinical disease and pathogenesis of malaria. *Parasitol. Today* 11(5): 2-15
- Migot F, Ouedraogo JB, Diallo J, Zampan H, Dubois B, *et al.*, (1996), Selected *P. falciparum* specific immune responses are maintained in AIDS adults in Burkina Faso. *Parasite Immunol* 18(7): 333-9.
- Miller K, Silverman P, Kullgren B and Mahlmann L, (1989), Tumor necrosis factor alpha and the anemia associated with murine malaria. *Infect. Immun.* 1989 May; 57(5): 1542-6
- Miller L, Good M and Kaslow D, (1997), The need for assays predictive of protection in development of malaria bloodstage vaccines. *Parasitol. Today* 13(2): 46-47
- Miller LH, Mason SJ, Clyde DF and McGinniss MH, (1976), The resistance factor to *Plasmodium vivax* in blacks. The Duffy-blood- group genotype, FyFy. *N. Engl. J. Med.* 295(6): 302-4.
- Miller LH, McGinniss MH, Holland PV and Sigmon P, (1978), The Duffy blood group phenotype in American blacks infected with *Plasmodium vivax* in Vietnam. *Am. J. Trop. Med. Hyg.* 27(6): 1069-72.
- Mitchell G, Butcher G, Voller A and Cohen S, (1976), The effect of human immune IgG on the *in vitro* development of *Plasmodium falciparum*. *Parasitology* 72(2): 149-62
- Modiano D, Chiacchiuini A, Petrarca V, Sirima B, Luoni G, *et al.*, (1998a), Humoral response to *Plasmodium falciparum* Pf155/ring-infected erythrocyte surface antigen and Pf332 in three sympatric ethnic groups of Burkina Faso. *Am. J. Trop. Med. Hyg.* 58(2): 220-4

- Modiano D, Sirima BS, Sawadogo A, Sanou I, Pare J, *et al.*, (1998b), Severe malaria in Burkina Faso: influence of age and transmission level on clinical presentation. *Am. J. Trop. Med. Hyg.* 59(4): 539-42.
- Modiano D, Sirima BS, Sawadogo A, Sanou I, Pare J, *et al.*, (1999), Severe malaria in Burkina Faso: urban and rural environment. *Parassitologia* 41(1-3): 251-4.
- Molineaux L, (1985), The pros and cons of modelling malaria transmission. *Trans. Roy. Soc. Trop. Med. Hyg.* 1985; 79(6): 743-7
- Molineux L, *Malaria, Principles and Practice of Malariology, 2, London, Churchill Livingstone, 1988,*
- Molyneux ME, Taylor TE, Wirima JJ and Borgstein A, (1989), Clinical features and prognostic indicators in paediatric cerebral malaria : A study of 131 comatose Malawian children. *Q. J. med. New series* 71(265): 441-459
- Moore JM, Nahlen BL, Misore A, Lal AA and Udhayakumar V, (1999), Immunity to placental malaria. I. Elevated production of interferon- gamma by placental blood mononuclear cells is associated with protection in an area with high transmission of malaria. *J. Infect. Dis.* 179(5): 1218-25.
- Nagel RL, (1990), Innate resistance to malaria: the intraerythrocytic cycle. *Blood Cells* 16(2-3): 321-39
- Najera J, (1974), A critical review of the field application of a mathematical model of malaria eradication. *Bull-World-Health-Organ.* 50(5): 449-57
- Nakamura K, Hasler T, Morehead K, Howard RJ and Aikawa M, (1992), *Plasmodium falciparum*-infected erythrocyte receptor(s) for CD36 and thrombospondin are restricted to knobs on the erythrocyte surface. *J Histochem Cytochem* 40(9): 1419-22.
- Newbold C, Pinches R, Roberts D and Marsh K, (1992), *Plasmodium falciparum*: the human agglutinating antibody response to the infected red cell surface is predominantly variant specific. *Exp. Parasitol.* 1992 Nov; 75(3): 281-92
- Newbold C, Craig A, Kyes S, Berendt A, Snow R, *et al.*, (1997a), PfEMP1, polymorphism and pathogenesis. *Ann. Trop. Med. Parasitol.* 91(5): 551-7
- Newbold C, Warn P, Black G, Berendt A, Craig A, *et al.*, (1997b), Receptor-specific adhesion and clinical disease in *Plasmodium falciparum*. *Am. J. Trop. Med. Hyg.* 57(4): 389-98.
- Newbold CI, (1999), Antigenic variation in *Plasmodium falciparum*: mechanisms and consequences. *Curr. Opin. Microbiol.* 2(4): 420-5.
- Newton C, Warn P, Winstanley P, Peshu N, Snow R, *et al.*, (1997), Severe anaemia in children living in malaria endemic area of Kenya. *Trop. Med. Int. He.* 2(2): 165-178
- Newton CR, Kirkham FJ, Winstanley PA, Pasvol G, Peshu N, *et al.*, (1991), Intracranial pressure in African children with cerebral malaria. *Lancet* 337(8741): 573-6.
- Newton CR, Peshu N, Kendall B, Kirkham FJ, Sowunmi A, *et al.*, (1994), Brain swelling and ischaemia in Kenyans with cerebral malaria. *Arch. Dis. Child.* 70(4): 281-7.
- Nguer C, Diallo T, Diouf A, Tall A, Dieye A, *et al.*, (1997), *Plasmodium falciparum*- and merozoite surface protein 1-specific antibody isotype balance in immune Senegalese adults. *Infect. Immun.* 1997 Nov; 65(11): 4873-6
- Ockenhouse C, Klotz F, Tandon N and Jamieson G, (1991), Sequestrin, a CD36 recognition protein on *Plasmodium falciparum* malaria-infected erythrocytes identified by anti-idiotypic antibodies. *Proc. Natl. Acad. Sci. USA.* 88(8): 3175-9

Ockenhouse CF, Tegoshi T, Maeno Y, Benjamin C, Ho M, *et al.*, (1992), Human vascular endothelial cell adhesion receptors for *Plasmodium falciparum*-infected erythrocytes: roles for endothelial leukocyte adhesion molecule 1 and vascular cell adhesion molecule 1. *J. Exp. Med.* 176(4): 1183-9.

Ockenhouse CF, Sun PF, Lanar DE, Welde BT, Hall BT, *et al.*, (1998), Phase I/IIa safety, immunogenicity, and efficacy trial of NYVAC-Pf7, a pox-vectored, multiantigen, multistage vaccine candidate for *Plasmodium falciparum* malaria. *J. Infect. Dis.* 177(6): 1664-73.

Okitolonda W, Delacollette C, Malengreau M and Henquin JC, (1987), High incidence of hypoglycaemia in African patients treated with intravenous quinine for severe malaria. *Br Med J (Clin Res Ed)* 295(6600): 716-8.

Oquendo P, Hundt E, Lawler J and Seed B, (1989), CD36 directly mediates cytoadherence of *Plasmodium falciparum* parasitized erythrocytes. *Cell.* 1989 58(1): 95-101

Panton LJ, Leech JH, Miller LH and Howard RJ, (1987), Cytoadherence of *Plasmodium falciparum*-infected erythrocytes to human melanoma cell lines correlates with surface OKM5 antigen. *Infect. Immun.* 55(11): 2754-8.

Pasquetto V, Fidock DA, Gras H, Badell E, Eling W, *et al.*, (1997), *Plasmodium falciparum* sporozoite invasion is inhibited by naturally acquired or experimentally induced polyclonal antibodies to the STARP antigen. *Eur J. Immunol* 27(10): 2502-13.

Pasvol G, Wilson RJ, Smalley ME and Brown J, (1978), Separation of viable schizont-infected red cells of *Plasmodium falciparum* from human blood. *Ann. Trop. Med. Parasitol.* 72(1): 87-8.

Pasvol G, (1986), The anaemia of malaria [editorial]. *Q. J. Med.* 58(227): 217-9

Perlmann H, Berzins K, Wahlgren M, Carlsson J, Bjorkman A, *et al.*, (1984), Antibodies in malarial sera to parasite antigens in the membrane of erythrocytes infected with early asexual stages of *Plasmodium falciparum*. *J. Exp. Med.* 159(6): 1686-704.

Pichyangkul S, Saengkrai P, Yongvanitchit K, Stewart A and Heppner DG, (1997), Activation of gammadelta T cells in malaria: interaction of cytokines and a schizont-associated *Plasmodium falciparum* antigen. *J. Infect. Dis.* 176(1): 233-41.

Picot S, Peyron F, Vuillez JP, Barbe G, Marsh K, *et al.*, (1990), Tumor necrosis factor production by human macrophages stimulated *in vitro* by *Plasmodium falciparum*. *Infect. Immun.* 58(1): 214-6.

Piper KP, Hayward RE, Cox MJ and Day KP, (1999a), Malaria transmission and naturally acquired immunity to PfEMP-1. *Infect. Immun.* 67(12): 6369-74.

Piper KP, Roberts DJ and Day KP, (1999b), *Plasmodium falciparum*: analysis of the antibody specificity to the surface of the trophozoite-infected erythrocyte. *Exp. Parasitol.* 91(2): 161-9

Plebanski M, Lee EA, Hannan CM, Flanagan KL, Gilbert SC, *et al.*, (1999), Altered peptide ligands narrow the repertoire of cellular immune responses by interfering with T-cell priming. *Nat. Med.* 5(5): 565-71.

Pongponratn E, Riganti M, Harinasuta T and Bunnag D, (1989), Electron microscopic study of phagocytosis in human spleen in *falciparum* malaria. *S.E. Asian J. Trop. Med. Public. Health.* 20(1): 31-9.

Pongponratn E, Riganti M, Punpoowong B and Aikawa M, (1991), Microvascular sequestration of parasitized erythrocytes in human *falciparum* malaria: a pathological study. *Am. J. Trop. Med. Hyg.* 44(2): 168-75.

Pretolani M and Goldman M, (1997), IL-10: a potential therapy for allergic inflammation? *Immunol Today* 18(6): 277-80.

Quakyi IA, Otoo LN, Pombo D, Sugars LY, Menon A, *et al.*, (1989), Differential non-responsiveness in humans of candidate *Plasmodium falciparum* vaccine antigens. *Am. J. Trop. Med. Hyg.* 41(2): 125-34.

Quigley MA, Armstrong-Schellenberg JR and Snow RW, (1996), Algorithms for verbal autopsies: a validation study in Kenyan children. *Bull. World. Health. Organ.* 74(2): 147-54

- Ranford-Cartwright L, Balfe P, Carter R and Walliker D, (1993), Frequency of cross-fertilization in the human malaria parasite *Plasmodium falciparum*. *Parasitology*. 107 (Pt 1): 11-8
- Reeder J, Rogerson S, al Y, F, Anders R, Coppel R, *et al.*, (1994), Diversity of agglutinating phenotype, cytoadherence, and rosette-forming characteristics of *Plasmodium falciparum* isolates from Papua New Guinean children. *Am. J. Trop. Med. Hyg.* 1994 Jul; 51(1): 45-55
- Reeder J, Davern K, Baird J, Rogerson S and Brown G, (1997), The age-specific prevalence of *Plasmodium falciparum* in migrants to Irian Jaya is not attributable to agglutinating antibody repertoire. *Acta. Trop.* 65(3): 163-73
- Ricke CH, Staalsoe T, Koram K, Akanmori BD, Riley EM, *et al.*, (2000), Plasma antibodies from malaria-exposed pregnant women recognize variant surface antigens on *Plasmodium falciparum*-infected erythrocytes in a parity-dependent manner and block parasite adhesion to chondroitin sulfate A. *J. Immunol* 165(6): 3309-16.
- Ridley RG, Takacs B, Etlinger H and Scaife JG, (1990a), A rhoptry antigen of *Plasmodium falciparum* is protective in Saimiri monkeys. *Parasitology* 101 Pt 2(187-92).
- Ridley RG, Takacs B, Lahm HW, Delves CJ, Goman M, *et al.*, (1990b), Characterisation and sequence of a protective rhoptry antigen from *Plasmodium falciparum*. *Mol. Biochem. Parasitol.* 41(1): 125-34.
- Rieckmann KH, Carson PE, Beaudoin RL, Cassells JS and Sell KW, (1974), Letter: Sporozoite induced immunity in man against an Ethiopian strain of *Plasmodium falciparum*. *Trans. Roy. Soc. Trop. Med. Hyg.* 68(3): 258-9
- Rihet P, Traore Y, Aucan C, Traore-Leroux T, Kumulungui B, *et al.*, (1999), Genetic dissection of *Plasmodium falciparum* blood infection levels and other complex traits related to human malaria infection. *Parassitologia* 41(1-3): 83-7.
- Riley E, Olerup O and Blomberg T, (1991), The immune recognition of malaria antigens. *Parasitol. Today* 7(1): 5-11
- Riley E, Allen S, Wheeler J, Blackman M, Bennett S, *et al.*, (1992), Naturally acquired cellular and humoral immune responses to the major merozoite surface antigen (PfMSP1) of *Plasmodium falciparum* are associated with reduced malaria morbidity. *Parasite. Immunol.* 14(3): 321-37
- Riley E, (1996), The role of MHC- and non-MHC-associated genes in determining the human immune response to malaria antigens. *Parasitology*. 1996; 112 Suppl: S39-51
- Riley EM, Ong CS, Olerup O, Eida S, Allen SJ, *et al.*, (1990), Cellular and humoral immune responses to *Plasmodium falciparum* gametocyte antigens in malaria-immune individuals. Limited response to the 48/45-kilodalton surface antigen does not appear to be due to MHC restriction. *J. Immunol* 144(12): 4810-6.
- Riley EM, (1999), Is T-cell priming required for initiation of pathology in malaria infections? *Immunol Today* 20(5): 228-33.
- Ringwald P, Peyron F, Lepers JP, Rabarison P, Rakotomalala C, *et al.*, (1993), Parasite virulence factors during *falciparum* malaria: rosetting, cytoadherence, and modulation of cytoadherence by cytokines. *Infect. Immun.* 61(12): 5198-204.
- Roberts D, Craig A, Berendt A, Pinches R, Nash G, *et al.*, (1992), Rapid switching to multiple antigenic and adhesive phenotypes in malaria. *Nature*. 1992 Jun 25; 357(6380): 689-92
- Roberts DD, Sherwood JA, Spitalnik SL, Panton LJ, Howard RJ, *et al.*, (1985), Thrombospondin binds *falciparum* malaria parasitized erythrocytes and may mediate cytoadherence. *Nature* 318(6041): 64-6.
- Robson KJ, Dolo A, Hackford IR, Doumbo O, Richards MB, *et al.*, (1998), Natural polymorphism in the thrombospondin-related adhesive protein of *Plasmodium falciparum*. *Am. J. Trop. Med. Hyg.* 58(1): 81-9.

Rock E, Saul A, Taylor D, Leech J, Sherwood J, *et al.*, (1988), Expression of the histidine-rich protein PfHRP1 by knob-positive *Plasmodium falciparum* is not sufficient for cytoadherence of infected erythrocytes. *Infect. Immun.* 56(12): 3301-4

Rockett KA, Awburn MM, Aggarwal BB, Cowden WB and Clark IA, (1992), *In vivo* induction of nitrite and nitrate by tumor necrosis factor, lymphotoxin, and interleukin-1: possible roles in malaria. *Infect. Immun.* 60(9): 3725-30.

Rodrigues M, Li S, Murata K, Rodriguez D, Rodriguez JR, *et al.*, (1994), Influenza and vaccinia viruses expressing malaria CD8+ T and B cell epitopes. Comparison of their immunogenicity and capacity to induce protective immunity. *J. Immunol* 153(10): 4636-48.

Rodriguez LE, Urquiza M, Ocampo M, Suarez J, Curtidor H, *et al.*, (2000), *Plasmodium falciparum* EBA-175 kDa protein peptides which bind to human red blood cells. *Parasitology* 120(Pt 3): 225-35.

Rogerson S, Novakovic S, Cooke B and Brown G, (1997), *Plasmodium falciparum*-infected erythrocytes adhere to the proteoglycan thrombomodulin in static and flow-based systems. *Exp. Parasitol.* 86(1): 8-18

Rogerson SC, SC; Ng, K; Reeder, JC; Brown, GV, (1995), Chondroitin sulfate A is a cell surface receptor for *Plasmodium falciparum*-infected erythrocytes. *J. Exp. Med.* 182(1): 15-20

Rogier C, Ly AB, Tall A, Cisse B and Trape JF, (1999a), *Plasmodium falciparum* clinical malaria in Dielmo, a holoendemic area in Senegal: no influence of acquired immunity on initial symptomatology and severity of malaria attacks. *Am. J. Trop. Med. Hyg.* 60(3): 410-20.

Rogier C, Tall A, Diagne N, Fontenille D, Spiegel A, *et al.*, (1999b), *Plasmodium falciparum* clinical malaria: lessons from longitudinal studies in Senegal. *Parassitologia* 41(1-3): 255-9.

Romero P, Maryanski J, Corradin G, Nussenzweig R, Nussenzweig V, *et al.*, (1989), Cloned cytotoxic T cells recognize an epitope in the circumsporozoite protein and protect against malaria. *Nature* 341(6240): 323-6

Rosenberg ZF and Fauci AS, (1990), Immunopathogenic mechanisms of HIV infection: cytokine induction of HIV expression. *Immunol Today* 11(5): 176-80.

Ross A, *The prevention of malaria, Murray, 1911,*

Rougemont A, Breslow N, Brenner E, Moret A, Dumbo O, *et al.*, (1991), Epidemiological basis for clinical diagnosis of childhood malaria in endemic zone in West Africa [see comments] *CM: Comment in: Lancet* 1991 Dec 21-28;338(8782-8783):1601. *Comment in: Lancet* 1992 Mar 14;339(8794):690; discussion 690-1. *Comment in: Lancet* 1992 Mar 14;339(8794):691. *Lancet* 338(8778): 1292-5

Rowe A, Obeiro J, Newbold CI and Marsh K, (1995), *Plasmodium falciparum* rosetting is associated with malaria severity in Kenya. *Infect. Immun.* 63(6): 2323-6.

Rowe J, Moulds J, Newbold C and Miller L, (1997), *P. falciparum* rosetting mediated by a parasite-variant erythrocyte membrane protein and complement-receptor 1. *Nature* 388(6639): 292-5

Rubio J, Thompson J and Cowman A, (1996), The var genes of *Plasmodium falciparum* are located in the subtelomeric region of most chromosomes. *EMBO J.* 15(15): 4069-77

Rudin W, Favre N, Bordmann G and Ryffel B, (1997), Interferon-gamma is essential for the development of cerebral malaria. *Eur. J. Immunol.* 27(4): 810-5

Rudzinska MA and Trager W, (1968), The fine structure of trophozoites and gametocytes in *Plasmodium coatneyi*. *J. Protozool.* 15(1): 73-88.

Ruwende C, Khoo S, Snow R, Yates S, Kwiatkowski D, *et al.*, (1995), Natural selection of hemi- and heterozygotes for G6PD deficiency in Africa by resistance to severe malaria. *Nature* 376(6537): 246-9

- Rzepczyk CM, Hale K, Woodroffe N, Bobogare A, Csurhes P, *et al.*, (1997), Humoral immune responses of Solomon Islanders to the merozoite surface antigen 2 of *Plasmodium falciparum* show pronounced skewing towards antibodies of the immunoglobulin G3 subclass. *Infect. Immun.* 65(3): 1098-100.
- Sabchareon A, Burnouf T, Ouattara D, Attanath P, Bouharoun-Tayoun H, *et al.*, (1991), Parasitologic and clinical human response to immunoglobulin administration in *falciparum* malaria. *Am. J. Trop. Med. Hyg.* 1991 Sep; 45(3): 297-308
- Salimonu LS, Williams AI and Osunkoya BO, (1982), IgG subclass levels in malaria-infected Nigerians. *Vox Sang* 42(5): 248-51
- Sarthou J, Angel G, Aribot G, Rogier C, Dieye A, *et al.*, (1997), Prognostic value of anti-*Plasmodium falciparum*-specific immunoglobulin G3, cytokines, and their soluble receptors in West African patients with severe malaria. *Infect. Immun.* 65(8): 3271-6
- Saul A, Lord R, Jones GL and Spencer L, (1992), Protective immunization with invariant peptides of the *Plasmodium falciparum* antigen MSA2. *J. Immunol* 148(1): 208-11.
- Saul A, (1999), The role of variant surface antigens on malaria-infected red blood cells. *Parasitol Today* 15(11): 455-7.
- Schellenberg J, Smith T, PL A and Hayes R, (1994), What is clinical Malaria? Finding case definition for field research in highly endemic areas. *Parasitol. Today* 10(1) 439-441
- Schellenberg D, Menendez C, Kahigwa E, Font F, Galindo C, *et al.*, (1999), African children with malaria in an area of intense *Plasmodium falciparum* transmission: features on admission to the hospital and risk factors for death. *Am. J. Trop. Med. Hyg.* 61(3): 431-8.
- Schmidt LH, Fradkin R, Sesler C, Squires W and Zeyen P, (1987), Attenuation of the virulence of the M strain of *Plasmodium cynomolgi* during prolonged multiplication in splenectomized rhesus monkeys. *Am. J. Trop. Med. Hyg.* 37(3): 460-90.
- Schofield L, Bushell GR, Cooper JA, Saul AJ, Upcroft JA, *et al.*, (1986), A rhoptry antigen of *Plasmodium falciparum* contains conserved and variable epitopes recognized by inhibitory monoclonal antibodies. *Mol. Biochem. Parasitol.* 18(2): 183-95.
- Schofield L, Villaquiran J, Ferreira A, Schellekens H, Nussenzweig R, *et al.*, (1987), Gamma interferon, CD8+ T cells and antibodies required for immunity to malaria sporozoites. *Nature* 330(6149): 664-6
- Schofield L, (1989), T cell immunity to malaria sporozoites. *Exp. Parasitol.* 68(3): 357-64
- Schofield L, (1991), On the function of repetitive domain in protein antigen of *Plasmodium* and eukaryotic parasites. *Parasitol. Today* 7(5): 99-105
- Scholander C, Carlson J, Kremsner PG and Wahlgren M, (1998), Extensive immunoglobulin binding of *Plasmodium falciparum*-infected erythrocytes in a group of children with moderate anemia. *Infect. Immun.* 66(1): 361-363
- Sedegah M, Hedstrom R, Hobart P and Hoffman SL, (1994), Protection against malaria by immunization with plasmid DNA encoding circumsporozoite protein. *Proc. Natl. Acad. Sci. USA* 91(21): 9866-70.
- Sedegah M, Jones TR, Kaur M, Hedstrom R, Hobart P, *et al.*, (1998), Boosting with recombinant vaccinia increases immunogenicity and protective efficacy of malaria DNA vaccine. *Proc. Natl. Acad. Sci. USA* 95(13): 7648-53.
- Sehgal V, Siddiqui W and Alpers M, (1989), A seroepidemiological study to evaluate the role of passive maternal immunity to malaria in infants. *Trans. Roy. Soc. Trop. Med. Hyg.* 1989; 83 Suppl: 105-6
- Senok AC, Li K, Nelson EA, Yu LM, Tian LP, *et al.*, (1997a), Invasion and growth of *Plasmodium falciparum* is inhibited in fractionated thalassaemic erythrocytes. *Trans. Roy. Soc. Trop. Med. Hyg.* 91(2): 138-43.

Senok AC, Nelson EA, Li K and Oppenheimer SJ, (1997b), Thalassaemia trait, red blood cell age and oxidant stress: effects on *Plasmodium falciparum* growth and sensitivity to artemisinin. *Trans. Roy. Soc. Trop. Med. Hyg.* 91(5): 585-9.

Sergent E and Parrot L, (1935), L'immunité, la prémunition et la résistance innée. *Archives de l'Institut Pasteur g'Algerie* 13(279-319)

Shai S, Blackman M and Holder A, (1995), Epitopes in the 19kDa fragment of the *Plasmodium falciparum* major merozoite surface protein-1 (PfMSP-1(19)) recognized by human antibodies. *Parasite. Immunol.* 1995 May; 17(5): 269-75

Sherry BA, Alava G, Tracey KJ, Martiney J, Cerami A, *et al.*, (1995), Malaria-specific metabolite hemozoin mediates the release of several potent endogenous pyrogens (TNF, MIP-1 alpha, and MIP-1 beta) *in vitro*, and altered thermoregulation *in vivo*. *J. Inflamm.* 45(2): 85-96

Sherwood JA, Roberts DD, Spitalnik SL, Marsh K, Harvey EB, *et al.*, (1989), Studies of the receptors on melanoma cells for *Plasmodium falciparum* infected erythrocytes. *Am. J. Trop. Med. Hyg.* 40(2): 119-27.

Shi Y, Sayed U, Qari S, Roberts J, Udhayakumar V, *et al.*, (1996), Natural immune response to the C-terminal 19-kilodalton domain of *Plasmodium falciparum* merozoite surface protein 1. *Infect. Immun.* 64(7): 2716-23

Shi YP, Udhayakumar V, Oloo AJ, Nahlen BL and Lal AA, (1999), Differential effect and interaction of monocytes, hyperimmune sera, and immunoglobulin G on the growth of asexual stage *Plasmodium falciparum* parasites. *Am. J. Trop. Med. Hyg.* 60(1): 135-41.

Silamut K and White NJ, (1993), Relation of the stage of parasite development in the peripheral blood to prognosis in severe *falciparum* malaria. *Trans. Roy. Soc. Trop. Med. Hyg.* 87(4): 436-43.

Singh J and Singh H, (1940), Observations on immunity in monkey malaria as evidenced by the results of superinfections. *J. Mal. Inst. India* 3(1): 99-114

Sinton J, (1939), A summary of our present knowledge of the mechanism of immunity in malaria. *J. Mal. Inst. India* 2(1):

Smith JD, Chitnis CE, Craig AG, Roberts DJ, Hudson-Taylor DE, *et al.*, (1995a), Switches in expression of *Plasmodium falciparum* var genes correlate with changes in antigenic and cytoadherent phenotypes of infected erythrocytes [see comments]. *Cell* 82(1): 101-10

Smith JD, Kyes S, Craig AG, Fagan T, Hudson-Taylor D, *et al.*, (1998), Analysis of adhesive domains from the A4VAR *Plasmodium falciparum* erythrocyte membrane protein-1 identifies a CD36 binding domain. *Mol. Biochem. Parasitol.* 97(1-2): 133-48.

Smith JD, Craig AG, Kriek N, Hudson-Taylor D, Kyes S, *et al.*, (2000a), Identification of a *Plasmodium falciparum* intercellular adhesion molecule-1 binding domain: a parasite adhesion trait implicated in cerebral malaria. *Proc. Natl. Acad. Sci. USA* 97(4): 1766-71.

Smith JD, Subramanian G, Gamain B, Baruch DI and Miller LH, (2000b), Classification of adhesive domains in the *Plasmodium falciparum* erythrocyte membrane protein 1 family. *Mol. Biochem. Parasitol.* 110(2): 293-310.

Smith T, Charlwood JD, Kihonda J, Mwankusye S, Billingsley P, *et al.*, (1993), Absence of seasonal variation in malaria parasitaemia in an area of intense seasonal transmission. *Acta Trop* 54(1): 55-72.

Smith T, Schellenberg J and Hayes R, (1994), Attributable fraction estimates and case definitions for malaria in endemic areas. *Statistics in Medicine* 13(2345-2358)

Smith T, Hurt N, Teuscher T and Tanner M, (1995b), Is fever a good sign for clinical malaria in surveys of endemic communities? *Am. J. Trop. Med. Hyg.* 52(4): 306-10

Smith T, Felger I, Tanner M and Beck HP, (1999), Premunition in *Plasmodium falciparum* infection: insights from the epidemiology of multiple infections. *Trans. Roy. Soc. Trop. Med. Hyg.* 93 Suppl 1(59-64).

Snow R, Omumbo J, Lowe B, Molyneux C, Obiero J, *et al.*, (1997), Relation between severe malaria morbidity in children and level of *Plasmodium falciparum* transmission in Africa [see comments] CM: Comment in: *Lancet* 1997 Jun 7;349(9066):1636-7. *Lancet* 349(9066): 1650-4

Snow RW, Armstrong JR, Forster D, Winstanley MT, Marsh VM, *et al.*, (1992), Childhood deaths in Africa: uses and limitations of verbal autopsies. *Lancet* 340(8815): 351-5.

Snow RW, Bastos de Azevedo I, Lowe BS, Kabiru EW, Nevill CG, *et al.*, (1994), Severe childhood malaria in two areas of markedly different *falciparum* transmission in east Africa. *Acta Trop* 57(4): 289-300.

Snow RW, Marsh K and Le Sueur D, (1996), The need for maps of transmission intensity to guide malaria control in Africa. *Parasitol. Today* 12(12): 455-457

Snow RW, Gouws E, Omumbo J, Rapuoda B, Craig MH, *et al.*, (1998a), Models to predict the intensity of *Plasmodium falciparum* transmission: applications to the burden of disease in Kenya. *Trans. Roy. Soc. Trop. Med. Hyg.* 92(6): 601-6.

Snow RW, Nahlen B, Palmer A, Donnelly CA, Gupta S, *et al.*, (1998b), Risk of severe malaria among African infants: direct evidence of clinical protection during early infancy. *J. Infect. Dis.* 177(3): 819-22

Snow RW, Craig MH, Deichmann U and le Sueur D, (1999), A preliminary continental risk map for malaria mortality among African children. *Parasitol Today* 15(3): 99-104.

Sokhna CS, Rogier C, Dieye A and Trape JF, (2000), Host factors affecting the delay of reappearance of *Plasmodium falciparum* after radical treatment among a semi-immune population exposed to intense perennial transmission. *Am. J. Trop. Med. Hyg.* 62(2): 266-70.

Sowunmi A, Walker O and Salako L, (1992), Hyperparasitaemia: not a reliable indicator of severity or poor prognosis in *falciparum* malaria in children in endemic African countries. *Ann. Trop. Paed.* 12(155-158)

Steketee RW, Wirima JJ, Bloland PB, Chilima B, Mermin JH, *et al.*, (1996), Impairment of a pregnant woman's acquired ability to limit *Plasmodium falciparum* by infection with human immunodeficiency virus type-1. *Am J Trop Med Hyg* 55(1): 42-9.

Su X, Heatwole V, Wertheimer S, Guinet F, Herrfeldt J, *et al.*, (1995), The large diverse gene family var encodes proteins involved in cytoadherence and antigenic variation of *Plasmodium falciparum*-infected erythrocytes [see comments] CM: Comment in: *Cell* 1995 Jul 14;82(1):1-4. *Cell* 82(1): 89-100

Suss G, Eichmann K, Kury E, Linke A and Langhorne J, (1988), Roles of CD4- and CD8-bearing T lymphocytes in the immune response to the erythrocytic stages of *Plasmodium chabaudi*. *Infect. Immun.* 56(12): 3081-8.

Taylor HM, Kyes SA and Newbold CI, (2000), Var gene diversity in *Plasmodium falciparum* is generated by frequent recombination events. *Mol. Biochem. Parasitol.* 110(2): 391-7.

Taylor R, Smith D, Robinson V, McBride J and Riley E, (1995), Human antibody response to *Plasmodium falciparum* merozoite surface protein 2 is serogroup specific and predominantly of the immunoglobulin G3 subclass. *Infect. Immun.* 63(11): 4382-8

Taylor RR, Allen SJ, Greenwood BM and Riley EM, (1998), IgG3 antibodies to *Plasmodium falciparum* merozoite surface protein 2 (MSP2): increasing prevalence with age and association with clinical immunity to malaria. *Am. J. Trop. Med. Hyg.* 58(4): 406-13.

Taylor TE, Molyneux ME, Wirima JJ, Fletcher KA and Morris K, (1988), Blood glucose levels in Malawian children before and during the administration of intravenous quinine for severe *falciparum* malaria. *N. Engl. J. Med.* 319(16): 1040-7.

Taylor-Robinson A and Philips R, (1993), Anti-malarial antibodies in twins. *Parasitol. Today* 9(1): 1-2

Taylor-Robinson A, (1995), Regulation of immunity to malaria: Valuable lessons learned from murine models. *Parasitol. Today* 11(9): 341

Taylor-Robinson A and Smith E, (1999), A role for cytokines in potentiation of malaria vaccines through immunological modulation of blood stage infections. *Immunol. Rev.* 171(105-124

Thelu J, Sheick-Zakiuddin I, Boudin C, Peyron F, Picot S, *et al.*, (1991), Development of natural immunity in *Plasmodium falciparum* malaria: study of antibody response by Western immunoblotting. *J. Clin. Microbiol.* 29(3): 510-8

Thomas AW, Trape JF, Rogier C, Goncalves A, Rosario VE, *et al.*, (1994), High prevalence of natural antibodies against *Plasmodium falciparum* 83- kilodalton apical membrane antigen (PF83/AMA-1) as detected by capture- enzyme-linked immunosorbent assay using full-length baculovirus recombinant PF83/AMA-1. *Am. J. Trop. Med. Hyg.* 51(6): 730-40.

Tolle R, Fruh K, Doumbo O, Koita O, N'Diaye M, *et al.*, (1993), A prospective study of the association between the human humoral immune response to *Plasmodium falciparum* blood stage antigen gp190 and control of malarial infections. *Infect. Immun.* 61(1): 40-7.

Trager W and Jensen JB, (1976), Human malaria parasites in continuous culture. *Science* 193(4254): 673-5

Trape J, Rogier C, Konate L, Diagne N, Bouganali H, *et al.*, (1994), The Dielmo project: a longitudinal study of natural malaria infection and the mechanisms of protective immunity in a community living in a holoendemic area of Senegal. *Am. J. Trop. Med. Hyg.* 51(2): 123-37

Trenholme KR, Gardiner DL, Holt DC, Thomas EA, Cowman AF, *et al.*, (2000), clag9: A cytoadherence gene in *Plasmodium falciparum* essential for binding of parasitized erythrocytes to CD36. *Proc. Natl. Acad. Sci. USA* 97(8): 4029-33.

Treutiger CJ, Hedlund I, Helmsby H, Carlson J, Jepson A, *et al.*, (1992), Rosette formation in *Plasmodium falciparum* isolates and anti-rosette activity of sera from Gambians with cerebral or uncomplicated malaria. *Am. J. Trop. Med. Hyg.* 46(5): 503-10.

Troye-Blomberg M, (1994), Human T-cell responses to blood stage antigens in *Plasmodium falciparum* malaria. *Immunol. Lett.* ; 41(2-3): 103-7

Tsuji M, Mombaerts P, Lefrancois L, Nussenzweig RS, Zavala F, *et al.*, (1994), Gamma delta T cells contribute to immunity against the liver stages of malaria in alpha beta T-cell-deficient mice. *Proc. Natl. Acad. Sci. USA* 91(1): 345-9.

Udeinya I, Miller L, McGregor I and Jensen J, (1983), *Plasmodium falciparum* strain-specific antibody blocks binding of infected erythrocytes to amelanotic melanoma cells. *Nature* 303(5916): 429-31

Udeinya IJ, Schmidt JA, Aikawa M, Miller LH and Green I, (1981), *Falciparum* malaria-infected erythrocytes specifically bind to cultured human endothelial cells. *Science* 213(4507): 555-7.

Udeinya IJ, (1990), *In vitro* and ex-vivo models of sequestration in *Plasmodium falciparum* infection. *Am. J. Trop. Med. Hyg.* 43(2 Pt 2): 2-5.

Udomsangpetch R, Wahlin B, Carlson J, Berzins K, Torii M, *et al.*, (1989), *Plasmodium falciparum*-infected erythrocytes form spontaneous erythrocyte rosettes. *J. Exp. Med.* 169(5): 1835-40

Udomsangpetch R, Sueblinvong T, Pattanapanyasat K, Dharmkrong-at A, Kittikalayawong A, *et al.*, (1993), Alteration in cytoadherence and rosetting of *Plasmodium falciparum*- infected thalassemic red blood cells. *Blood* 82(12): 3752-9.

Udomsangpetch R, Reinhardt P, Schollaardt T, Elliott J, Kubes P, *et al.*, (1997), Promiscuity of clinical *Plasmodium falciparum* isolates for multiple adhesion molecules under flow conditions. *J-Immunol.* 1997 May 1; 158(9): 4358-64

Urban BC, Ferguson DJ, Pain A, Willcox N, Plebanski M, *et al.*, (1999), *Plasmodium falciparum*-infected erythrocytes modulate the maturation of dendritic cells. *Nature* 400(6739): 73-7

- Van Schravendijk MR, Pasloske BL, Baruch DI, Handunnetti SM and Howard RJ, (1993), Immunochemical characterization and differentiation of two approximately 300-kD erythrocyte membrane-associated proteins of *Plasmodium falciparum*, PfEMP1 and PfEMP3. *Am. J. Trop. Med. Hyg.* 49(5): 552-65.
- Vande Waa JA, Jensen JB, Akood MA and Bayoumi R, (1984), Longitudinal study on the *in vitro* immune response to *Plasmodium falciparum* in Sudan. *Infect. Immun.* 45(2): 505-10.
- Verra F and Hughes AL, (1999), Natural selection on apical membrane antigen-1 of *Plasmodium falciparum*. *Parassitologia* 41(1-3): 93-5.
- Voigt S, Hanspal M, LeRoy PJ, Zhao PS, Oh SS, *et al.*, (2000), The cytoadherence ligand *Plasmodium falciparum* erythrocyte membrane protein 1 (PfEMP1) binds to the *P. falciparum* knob-associated histidine-rich protein (KAHRP) by electrostatic interactions. *Mol. Biochem. Parasitol.* 110(2): 423-8.
- Vounatsou P, Smith T, Kitua AY, Alonso PL and Tanner M, (2000), Apparent tolerance of *Plasmodium falciparum* in infants in a highly endemic area. *Parasitology* 120(Pt 1): 1-9.
- Wahlgren M, Berzins K, Perlmann P and Persson M, (1983), Characterization of the humoral immune response in *Plasmodium falciparum* malaria. II. IgG subclass levels of anti-*P. falciparum* antibodies in different sera. *Clin-Exp-Immunol.* 54(1): 135-42
- Wahlgren M, Bjorkman A, Perlmann H, Berzins K and Perlmann P, (1986), Anti-*Plasmodium falciparum* antibodies acquired by residents in a holoendemic area of Liberia during development of clinical immunity. *Am. J. Trop. Med. Hyg.* 35(1): 22-9.
- Wahlgren M, Carlson J, Ruangjirachuporn W, Conway D, Helmby H, *et al.*, (1990), Geographical distribution of *Plasmodium falciparum* erythrocyte rosetting and frequency of rosetting antibodies in human sera. *Am. J. Trop. Med. Hyg.* 43(4): 333-8
- Wahlgren M, Fernandez V, Scholander C and Carlson J, (1994), Rosetting. *Parasitol. Today* 10(2): 73-78
- Wahlin B, Wahlgren M, Perlmann H, Berzins K, Bjorkman A, *et al.*, (1984), Human antibodies to a Mr 155,000 *Plasmodium falciparum* antigen efficiently inhibit merozoite invasion. *Proc. Natl. Acad. Sci. USA* 81(24): 7912-6.
- Wahlin Flyg B, Siddique AB, Perlmann P, Esposito F and Berzins K, (1999), Inhibition of *in vitro* growth of *Plasmodium falciparum* field isolates mediated by human antibodies to Pf155/RESA and Pf332. *Parasite Immunol* 21(6): 331-4.
- Waitumbi JN, Opollo MO, Muga RO, Misore AO and Stoute JA, (2000), Red cell surface changes and erythrophagocytosis in children with severe *Plasmodium falciparum* anemia. *Blood* 95(4): 1481-6
- Waller D, Krishna S, Crawley J, Miller K, Nosten F, *et al.*, (1995), Clinical features and outcome of severe malaria in Gambian children. *Clin. Infect. Dis.* 21(577-87
- Wang R, Doolan DL, Le TP, Hedstrom RC, Coonan KM, *et al.*, (1998), Induction of antigen-specific cytotoxic T lymphocytes in humans by a malaria DNA vaccine. *Science* 282(5388): 476-80.
- Ward CP, Clotney GT, Dorris M, Ji DD and Arnot DE, (1999), Analysis of *Plasmodium falciparum* PfEMP-1/var genes suggests that recombination rearranges constrained sequences. *Mol. Biochem. Parasitol.* 102(1): 167-77.
- Warrell DA, Looareesuwan S, Phillips RE, White NJ, Warrell MJ, *et al.*, (1986), Function of the blood-cerebrospinal fluid barrier in human cerebral malaria. *Am. J. Trop. Med. Hyg.* 35(5): 882-889
- Waterfall M, Black A and Riley E, (1998), Gammadelta+ T cells preferentially respond to live rather than killed malaria parasites. *Infect. Immun.* 66(5): 2393-8.

Waterkeyn JG, Wickham ME, Davern KM, Cooke BM, Coppel RL, *et al.*, (2000), Targeted mutagenesis of *Plasmodium falciparum* erythrocyte membrane protein 3 (PfEMP3) disrupts cytoadherence of malaria-infected red blood cells. *Embo J* 19(12): 2813-23.

Weatherall D, (1996), Host genetics and infectious disease. *Parasitology*. 1996; 112 Suppl: S23-9

Weatherall DJ, (1997), Thalassaemia and malaria, revisited. *Ann. Trop. Med. Parasitol.* 91(7): 885-90.

Weiss L, Geduldig U and Weidanz W, (1986), Mechanisms of splenic control of murine malaria: reticular cell activation and the development of a blood-spleen barrier. *Am J Anat* 176(3): 251-85.

Weiss W, Sedegah M, Beaudoin R, Miller L and Good M, (1988), CD8+ T cells (cytotoxic/suppressors) are required for protection in mice immunized with malaria sporozoites. *Proc. Natl. Acad. Sci. USA*. 1988 Jan; 85(2): 573-6

Wernsdorfer W and McGregor IA, *Malaria: Principles and practice of malariology, 2, London, Churchill Livingstone, 1988, 913 - 1091*

Whitworth J, Morgan D, Quigley M, Smith A, Mayanja B, *et al.*, (2000), Effect of HIV-1 and increasing immunosuppression on malaria parasitaemia and clinical episodes in adults in rural Uganda: a cohort study. *Lancet* 356(9235): 1051-6.

WHO, Ad hoc committee of health research relating to future intervention options. Investing in health research and development. *Geneva, 1996*

WHO, (2000), Severe *falciparum* malaria. World Health Organization, Communicable Diseases Cluster [In Process Citation]. *Trans. Roy. Soc. Trop. Med. Hyg.* 94 Suppl 1(S1-90

Willmann K, Matile H, Weiss NA and Imhof BA, (1995), *In vivo* sequestration of *Plasmodium falciparum*-infected human erythrocytes: a severe combined immunodeficiency mouse model for cerebral malaria. *J. Exp. Med.* 182(3): 643-53.

Wilson RJ, Farrant J and Walter CA, (1977), Preservation of intraerythrocytic forms of malarial parasites by one- step and two-step cooling procedures. *Bull. World. Health. Organ.* 55(2-3): 309-15

Winkler S, Willheim M, Baier K, Schmid D, Aichelburg A, *et al.*, (1998), Reciprocal regulation of Th1- and Th2-cytokine-producing T cells during clearance of parasitemia in *Plasmodium falciparum* malaria. *Infect. Immun.* 66(12): 6040-4.

Winkler S, Willheim M, Baier K, Schmid D, Aichelburg A, *et al.*, (1999), Frequency of cytokine-producing T cells in patients of different age groups with *Plasmodium falciparum* malaria. *J. Infect. Dis.* 179(1): 209-16.

Yanez DM, Batchelder J, van der Heyde HC, Manning DD and Weidanz WP, (1999), Gamma delta T-cell function in pathogenesis of cerebral malaria in mice infected with *Plasmodium berghei* ANKA. *Infect. Immun.* 67(1): 446-8.

Yuthavong Y, Bunyaratvej A and Kamchonwongpaisan S, (1990), Increased susceptibility of malaria-infected variant erythrocytes to the mononuclear phagocyte system. *Blood* 16(602-604

Yuthavong Y and Wilairat P, (1993), Protection against malaria by thalassaemia and haemoglobin variants. *Parasitol. Today* 9(7): 241-145

Yuthavong Y and Wilairat P, (1997), Is the high incidence of malaria in alpha-thalassaemic children evidence against the 'Malaria hypothesis' ? *Parasitol. Today* 13(6): 207

Appendix I

SOURCE OF REAGENTS AND CONSUMABLES

PROCEDURE	REAGENT	SUPPLIER
Blood collection	Heparin	LEO LABS LTD, Bucks, UK
Parasite culture and cryopreservation	Malaria non-immune sera	BLOOD TRANSFUSION SERVICES <i>Southmead Road, Bristol, UK</i>
	Lymphoprep	NYCOMED PHARMA AS, <i>Oslo, Norway</i>
	Plasmagel	SIGMA ALDRICH CO LTD, <i>Dorset, UK</i>
	Hypoxanthine	SIGMA
	RPMI 1640	GIBCO-BRL LIFE TECHNOLOGIES LTD, <i>Paisley, UK</i>
	Hepes buffer	GIBCO
	Gentamicin sulphate	GIBCO
	L-glutamine	GIBCO
	Glucose	BDH (Merck Ltd), <i>Leicester, UK</i>
	Sodium hydroxide	BDH
	Aphidicolin	BDH
	Sodium lactate	BDH
	Giensa	BDH
	Immersion oil	BDH
	Glycerol	BDH
	Sodium dihydrogen phosphate	BDH
	Potassium chloride	BDH
	Methanol	BDH
Sodium chloride	BDH	
Special culture gas mixture	BOC (K) LTD, <i>Nairobi, Kenya</i>	
Agglutination	Ethidium bromide	SIGMA
	Acridine orange	SIGMA
	DAPI	SIGMA
	Petroleum jelly	JOHSON & JOHNSON (K) LTD, <i>Nairobi, Kenya</i>
Flow cytometry	Bovine serum albumin	GIBCO
	Phosphate buffer saline tablets	BDH
	FITC-conjugate sheep anti-human IgM, IgG & IgG subclasses	BINDING SITE, <i>Birmingham, UK</i>
	Ethidium bromide	SIGMA

SOURCE OF REAGENTS AND CONSUMABLES *cont'd...*

PROCEDURE	REAGENT	SUPPLIER
Western Blot	Anti-proteases - TLCK, TPCK, PMSF, antipain, Aprotinin, leupatin, chymostatin	SIGMA
	Tris (trizma base)	SIGMA
	Sodium dodecyl sulphate (SDS)	SIGMA
	Coomasie blue	BDH
	β - Mercaptoethanol	BDH
	Tween - 20	BDH
	Glycine	BDH
	HRP-conjugate rabbit Anti-human IgM, IgG & IgG - Subclasses	DAKO, <i>Cambridgeshire, UK</i>
	Protogel acrylamide	SIGMA
	Fat free milk	PREMIER BEVERAGE, <i>Stafford, UK</i>
	Photography film	AMERSHAM LIFE SCIENCE LTD, <i>Buckinghamshire, UK</i>
	High precision Molecular weight markers	AMERSHAM LIFE SCIENCE
	TEMED	GIBCO
	Ammonia persulphate	GIBCO
	HCl	FISHER SCIENTIFIC UK, <i>Leicestershire, UK</i>
	Acetic acid	FISHER SCIENTIFIC
	Nitrocellulose membrane	PHARMACIA BIOTECH, <i>Hertfordshire, UK</i>
	ECL Reagents	BOEHRINGER MANNHEIM, <i>Sussex UK</i>

CONSUMABLES

ITEM	SUPPLIER
Culture flasks 50ml, 250ml	BECTON DICKINSON, <i>France</i>
microtitre trays u-bottom well	BECTON DICKINSON
Syringes	BECTON DICKINSON
Needles	BECTON DICKINSON
Microtainer Serum Separator tubes	BECTON DICKINSON, <i>New jersey, USA</i>
Aspirating pipettes 2ml	FARENHEIT, <i>Milton Keynes, UK</i>
Pipettes plastic disposable 1ml, 5ml, 10ml, 25ml	FARENHEIT
Filter disk 0.22um	FARENHEIT
Centrifuge tubes , 15ml, 50ml	FARENHEIT
Pasteur pipette plastic sterile (fine)	ALPHA, <i>Hampshire, UK</i>
Pipette micro-volume tips 0.5 - 10ul	ALPHA
Pipette tips Yellow (200ul), Blue (1000ul)	SARSTEDT, <i>Leicester, UK</i>
Pasteur pipettes glass (150mm)	PATTERSON, <i>Luton, UK</i>
Glass slides and cover slips	CHANCE PROPPER LTD, <i>Warley, UK</i>
Cryovials 1.2ml	JENCONS, <i>Bedfordshire, UK</i>
Sample tubes, 1.5ml	JENCONS
Eppendorf tubes, 0.5ml, 1.5ml	ADERMAN & CO, <i>Surrey, UK</i>

Appendix II

KEMRI RESEARCH UNIT KILIFI

INFORMED CONSENT

Title of Study: Kinetics of responses to the surface of red cells infected by malaria schizonts.

Investigators: Prof. Kevin Marsh, Samson Kinyanjui

We would like to do a study to understand the way the body develops ability to fight malaria parasites. It is known that adults are able to fight malaria parasites and avoid becoming sick while children are infected easily and become very sick. This study will help us understand the following things.

1. The way the body fights malaria infection
2. How this capability develop as a child grows
3. How we can develop vaccine to prevent malaria infection

To do carry out this study we will need to obtain blood samples from children when they are sick and the 1, 2, 3, 6, 9, and 12 weeks after treatment. The blood samples will be obtained from the child's arm by a trained clinician . This process may be slightly painful but will not harm the child. We are requesting you to allow your child to participate in this study.

Your child will benefit in having regular examination for fever and malaria parasites and receiving prompt treatment. The results of this study will help us in understanding better how we can prevent malaria. However, your child's participation is purely voluntary and you will in no way be penalized for refusing to your child to participate. You will also be free be withdraw him/her from the study anytime you wish without any explanation. Please feel free to ask any questions about the study and if after this discussion you have decided to allow you child to participate in this study, we would like you to sign the accompanying form

I, _____ the (mother/father/guardian) of the children listed here below confirm that _____ has explained this study to me in Kiswahili / Kigiriyama /English which is a language in which I am fluent. In giving consent to this study I understand that refusal or withdrawal of consent will in no way prejudice my child's treatment, and that I may withdraw my child from the study at any time.

Signature or thumb print _____ (guardian/father/mother)

Date _____

Name of person obtaining consent _____

Signature _____

Investigator _____

Appendix III

KEMRI RESEARCH UNIT KILIFI

INFORMED CONSENT (children)

Title of Study: The Natural History Of Acquired Immunity To Malaria.

Investigators: Prof. Kevin Marsh Dr. Tabitha Mwangi, Samson Kinyanjui, Victor Odera, Dr. Peter Bull, Dr. Bob Snow,

We would like to do a study to try to improve the diagnosis, treatment and prevention of malaria. In this study, we are interested in trying to understand two things about malaria. Firstly, we want to know the various symptoms that accompany mild malaria fevers, treated at outpatient clinics or at home without admission to hospital. Secondly would like to study the way the body's ability to resist infection by malaria parasites develops as a person becomes older.

To do this we need to follow up a group of children and adults for a year during which period we will record all cases of fever and the presence of malaria parasite in their blood. We are requesting you to allow your child to participate in this study.

At the start of the study, you will be provided with bus fare to take your child to Kilifi District Hospital where he/she shall be examined for fever and asked to give a small volume of blood to be examined for malaria parasites. After this, your child will be followed up for a year. During this period, KEMRI workers will visit you once a week and take his/her body temperature. If your child has fever, a small blood sample will be drawn from him/her by a prick on the finger to make a malaria slide. You will be given bus fare to take the child to Kilifi District Hospital where he/she will receive treatment and bus fare for your journey back home. You will also be requested to bring the child back to the hospital two weeks after treatment where a small volume of blood will be taken for immunity studies. All volumes of blood will be taken by trained personnel. A special cream shall be applied on the part to be pricked to reduce pain.

A blood smear will also be made if your child has had a fever at any time since the last visit by KEMRI workers even though he/she is well during the current visit, If malaria parasites are found on the smear, the workers will bring you antimalarial drugs the next day.

A general examination in of all the participants similar to the one at the beginning of the study will be carried out halfway through the study and at the end of the study

Your child will benefit in having regular examination for fever and malaria parasites and receiving prompt treatment. The results of this study will help us in understanding how we can best diagnose, treat and prevent malaria. However, your child's participation is purely voluntary and you will in no way be penalized for refusing to your child to participate. You will also be free be withdraw him/her from the study anytime you wish without any explanation. Please feel free to ask any questions about the study and if after this discussion you have decided to allow you child to participate in this study, we would like you to sign the accompanying form

I, _____ the (mother/father/guardian) of the children listed here below confirm that _____ has explained this study to me in Kiswahili / Kigiriama /English which is a language in which I am fluent. In giving consent to

this study I understand that refusal or withdrawal of consent will in no way prejudice my child's treatment, and that I may withdraw my child from the study at any time.

Signature or thumb print _____ (guardian/father/mother)

Date _____

Name of person obtaining consent _____

Signature _____ Investigator _____

List of children

Enumeration zone |__|__| Household No |__|__|__|__|

Relation with the consenter - mother [] father [] guardian []

Brady no	Name	Age	School	Class