



Citation for published version:

Rodger, D, Lai, HC, Hill-Cottingham, RJ, Coles, PC & Robinson, F 2006, 'A New High Efficiency Line Start Motor with High Starting Torque' Paper presented at Power Electronics, Machines and Drives, 2006. The 3rd IET International Conference on, 1/01/06, pp. 551-555.

Publication date:
2006

Document Version
Early version, also known as pre-print

[Link to publication](#)

University of Bath

General rights

Copyright and moral rights for the publications made accessible in the public portal are retained by the authors and/or other copyright owners and it is a condition of accessing publications that users recognise and abide by the legal requirements associated with these rights.

Take down policy

If you believe that this document breaches copyright please contact us providing details, and we will remove access to the work immediately and investigate your claim.

A New High Efficiency Line Start Motor with High Starting Torque

D. Rodger, H.C. Lai, R.J. Hill-Cottingham, P.C. Coles, F. Robinson

Dept of Electronic and Electrical Engineering, University of Bath, Bath Avon BA2 7AY, U.K.

e-mail: d.rodger@bath.ac.uk

Abstract

A new electrical machine which starts directly on line and does not require power electronics has been developed. Compared with the standard line start induction motor it has about 30% less losses and a similar starting performance. The new machine has a conventional stator and a two part rotor.

1 Introduction

A new fixed speed line start permanent magnet machine (LSPM) is described here for the first time. The machine requires no power electronics and can be designed to have similar starting performance to a squirrel cage induction machine. The machine has a two part rotor shown disassembled in Fig. 1. The performance of a 4kW prototype machine is compared with that of an EFF1 efficiency band induction motor. Efficiency savings of around 3% and an improved power factor are demonstrated.

It has been estimated that in Europe, induction machines consume around 50% of all electricity generated. This is also true in the UK, electric motors consume around half of all generated electricity and about 66% of generated electricity used by industry.

'It is estimated that over 10 million motors, with a total capacity of 70GW, are installed in UK industry. The annual cost of running these machines is about £3000 million, while a further £1000 million is spent each year on electrical energy for motors in commercial applications. Most of these drives are powered by three-phase induction motors rated up to 300kW' [1] In financial terms, a 3% increase in electric motor efficiency equates to a saving of £120 million per annum. The saving in green house gas emission is also significant. As an example, the electrical power required to keep a 1kW motor running continuously for a year is 8760kW hours. A coal fired power station emits about 1 kg of CO₂ per kW hour, so, neglecting losses in the grid, the 1kW motor causes 8.76 tonnes of CO₂ to be emitted per annum.

Induction machine efficiency has been greatly improved in the last 100 years or so, better materials have contributed a large amount to increased efficiency, and improved design has also been important. However, one of the few avenues open to a manufacturer seeking a large improvement in efficiency

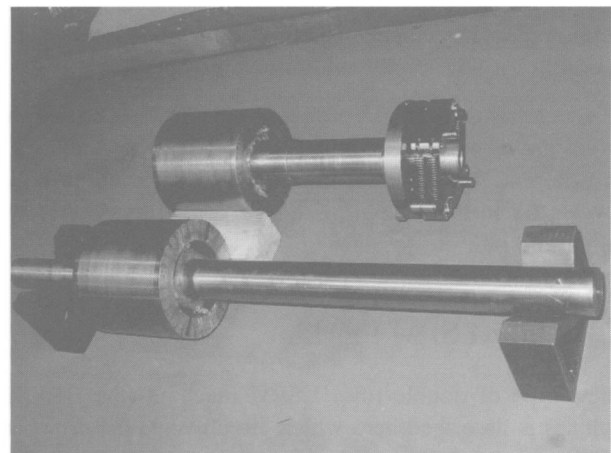

Fig. 1. Showing the prototype machine double rotors and release mechanism.

involves using hybrid permanent magnet (PM)-induction machines, often known as line start permanent magnet (LSPM) motors. These machines generally comprise a conventional n -pole induction machine stator and a special rotor. The rotor is fitted with a conventional rotor cage and also permanent magnets, to provide n rotor poles. The conductors on the rotor provide asynchronous torque below synchronous speed to accelerate and run up the rotor from rest and the permanent magnets provide synchronising torque to lock the rotor in at synchronous speed.

Once the rotor is synchronised, the cage no longer carries currents, and so rotor losses are significantly reduced compared with a conventional cage motor. As a result of this, the losses in an LSPM are typically 30% lower than those of an induction motor of equivalent rating, giving a significant increase in efficiency. In effect, an LSPM brings the efficiency advantage of PM construction without the attendant need for control electronics to provide starting capability. Furthermore, the cage acts as a damper once the rotor is synchronised, reducing unwanted speed oscillations caused by pulsating or shock loads, and provides an automatic resynchronising capability should a temporary overload cause the rotor to drop out of synchronism.

The basic principles of operation of LSPM machines have been known for many years. The development of PM machines started at least as far back as the early fifties [2],

and a hybrid PM- induction start machine is described in [3].

Despite this, LSPM machines have never been manufactured in numbers which come anywhere close to those of the equivalent sized workhorse induction machine. There are two main reasons for this.

The first is cost. The initial purchase cost of an LSPM machine must be more than an induction machine of a given volume because of the PM material. However this gap is narrowing as the price of PM material has recently fallen. When life time costs are considered, however, the hybrid machine soon pays back its initial cost premium, often in the order of a few months of continuous operation.

The second is a technical problem, it is difficult to optimise the design of a conventional LSPM, which is a hybrid of two different types of machine. This leads to compromises between, for instance, starting torque, supply transients, over-heating and pull out torque.

2 The new LSPM machine

A new type of double rotor LSPM machine (the DRLSPM machine) is described here which circumvents the drawbacks of the conventional LSPM. The design of a conventional LSPM machine is a compromise between the design of an induction machine and a synchronous machine. Good locking performance depends on high asynchronous torques near synchronous speed and high synchronous torques at synchronous speed. Unfortunately, maximising induction torque near synchronous speed (by lowering cage resistance) tends to reduce induction starting performance, while increasing synchronous torque capability by increasing reluctance and/or PM torques also increases drag, with the consequent possibility of crawling at subsynchronous speeds. The poor starting performance tends to limit the application of conventional LSPM machines to fan type loads which require little effort at standstill and build up smoothly to full load at the running speed. The new machine overcomes the disadvantages of the traditional LSPM by using a two part rotor which allows cancellation of unwanted PM fields during run up.

The rotor utilises normal cage construction but with buried permanent magnets. The rotor is split into two parts; one fixed permanently to the shaft, the other axially fixed but allowed to rotate on the shaft through a limited angle of $\pm 180^\circ$ electro-magnetic. At standstill, a mechanism is used to hold the two parts of the rotor at 180° electro-magnetic with respect to each other. This means that the magnetic field from the permanent magnets will tend to cancel. This is shown in Fig. 2, for the particular case of a four-pole machine. Thus when the stator is energised, the machine behaves as an ordinary induction motor and starts in the usual way. At some speed less than synchronous speed, the mechanism will release the moving rotor part, which because of its relatively low inertia will move rotationally with respect to the fixed rotor. When the rotor has moved to the nil-relative-displacement position, illustrated in

Fig. 3, the mechanism will lock its position with respect to the fixed rotor. The machine will now behave as a permanent magnet synchronous machine, and synchronise to the stator travelling field in the normal way. The mechanism may be integrated within the machine, or be mounted external to the main housing. It may be operated automatically (for example centrifugally), or by some external control.

A prototype DRLSPM machine based on an EFF1 4kW induction machine from a reputable manufacturer was built. The stator and frame were unchanged but a new double rotor, each part with cage and permanent magnets, was designed. The new rotor lamination was based on that of the original rotor, but with extra slots cut for the PM material. In order to avoid casting aluminium, for convenience a fabricated copper (Cu) cage was used instead of the original cast aluminium (Al). In order that the performance of the new Cu rotor would not be too different from that of the Al rotor, the whole of the rotor slot was not filled with Cu. The rotor bars consisted of three Cu bars, as shown in Fig. 4. A cross section of the machine is shown in Fig. 5. A photograph of the rotors is shown in Fig. 1. The centrifugal release mechanism is on the top rotor in Fig. 1, for convenience in observing the behaviour of the prototype, the release mechanism is on the outside of the motor housing. The whole of the top rotor of Fig. 1 is mounted on a sleeve which is then put on the shaft of the lower rotor. At predetermined speeds dependent on preloaded springs, the release mechanism unlatches the free rotor which turns 90° with respect to the fixed rotor.

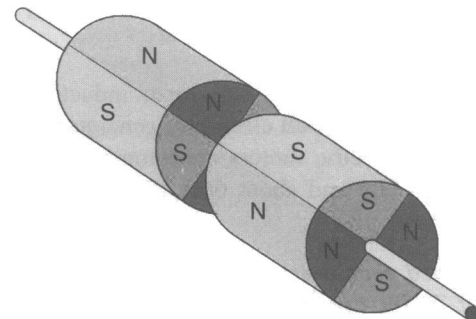

Fig. 2. Magnet orientation on rotor at standstill and initial runup (unaligned).

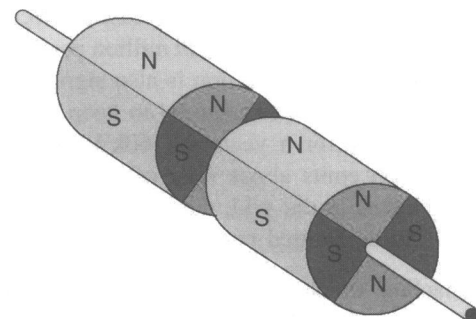

Fig. 3. Magnet orientation on rotor at normal running (aligned).

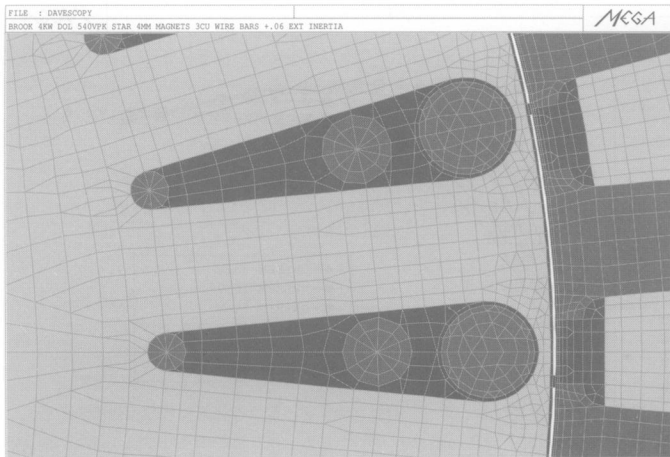

Fig. 4. Finite Element mesh showing the triple Cu bar used in the prototype cage.

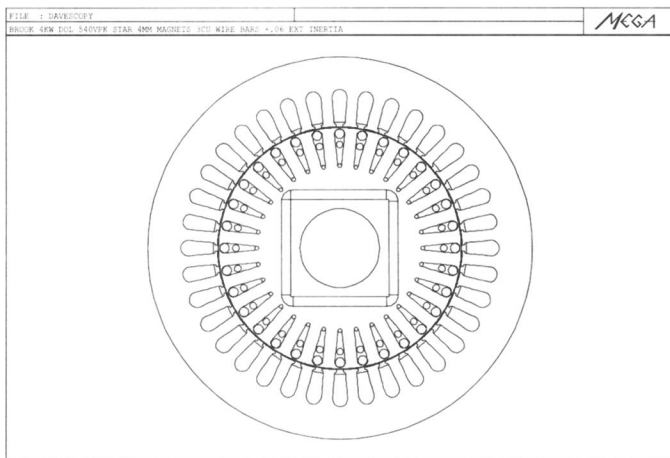

Fig. 5. Cross section of the DRLSPM prototype machine.

3 Performance comparisons between the new DRLSPM machine and a conventional EFF1 induction machine

The new DRLSPM machine was compared with a 4kW EFF1 induction machine, at various loads and voltages. The test rig and DRLSPM machine is shown in Fig. 6. The end bells of the motor frame are supported by bearings in plummer blocks, in such a way that the frame is free to swing. The frame is restrained by a load cell, which is used to measure the torque. The centrifugal switch may be seen in the foreground. Both machine torques are measured in the same way, and are both varied using a DC load machine.

Fig. 7 shows the speed (in rads/s) versus time when the DRLSPM machine is switched on at full voltage. The measured speed curve is the noisiest curve in Fig. 7, due to mechanical vibration in the rig. Also shown is a time transient simulation carried out using our finite element code, MEGA. The simulated speed of both rotors is shown. This speed is identical up to 140rads/s because the rotors are locked together

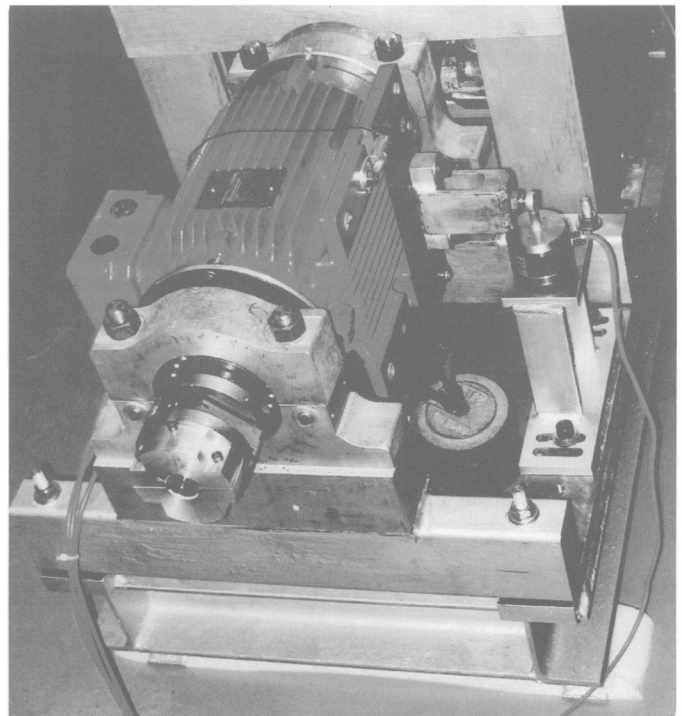

Fig. 6. Showing the test rig.

in the orientation depicted in Fig. 2. At 140rads/s they are unlocked by the centrifugal mechanism and the free rotor, now unloaded, increases speed and moves 90° with respect to the rotor which is fixed to the shaft. The rotors are locked together again in the orientation shown in Fig. 3 at about 0.55s. The double rotor then synchronises with the travelling wave at 157rads/s (1500rpm).

Since the movement of one of the rotors of the DRLSPM machine relative to the other is important to the action of the machine, the finite element model involves solving the time transient behaviour of both rotors simultaneously. The centrifugal switch is modelled as well, to release at 140rads/s and to clamp the two rotors together after the 90° move has taken place. Fig. 8 shows the computer model at one instant in time just after the free rotor is locked in the aligned position.

The two machines were tested at various loads and with three different supply voltages, 381, 363 and 346V. One of the machines was a conventional industrial high efficiency EFF1 induction machine. EFF1 for a 4kW 4 pole induction machine implies an efficiency greater than or equal to 88.3%. The DRLSPM machine used an identical stator to the 4kW induction machine, but was fitted with the new double rotor.

Fig. 9 shows that the efficiency of the DRLSPM machine is improved as compared with the induction machine. At the rated output power of 4kW and the design voltage of 381V, the efficiency is 91.5% for the DRLSPM and 88.4% for the induction motor. The DRLSPM efficiency remains at 90% or above over a wide range of power output, from 1kW to 5kW.

Fig. 10 shows that the power factor of the DRLSPM is also

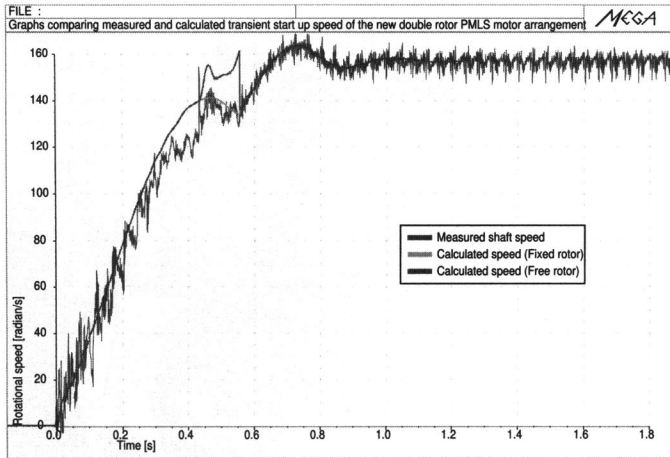

Fig. 7. Variation in speed during an on line start of the DRLSPM.

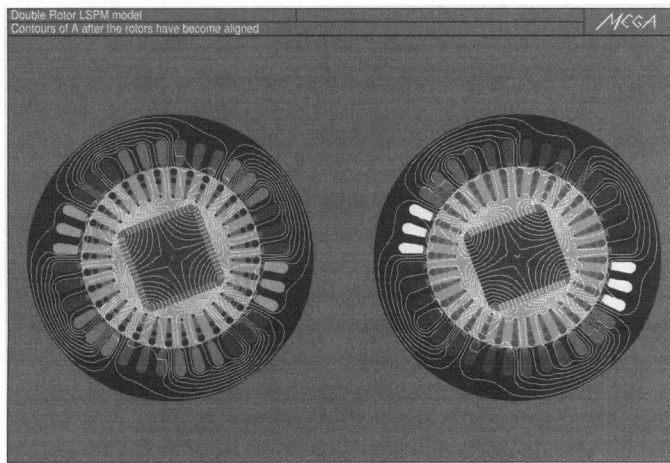

Fig. 8. The DRLSPM machine just after the free rotor is aligned

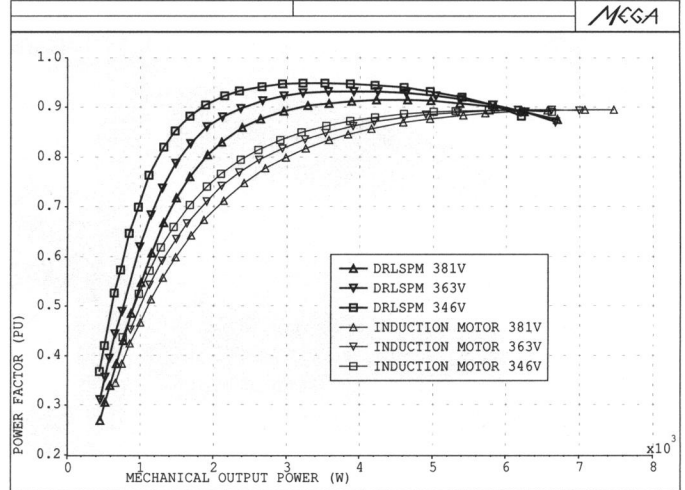

Fig. 10. Power factor of the new machine compared with an EFF1 induction machine.

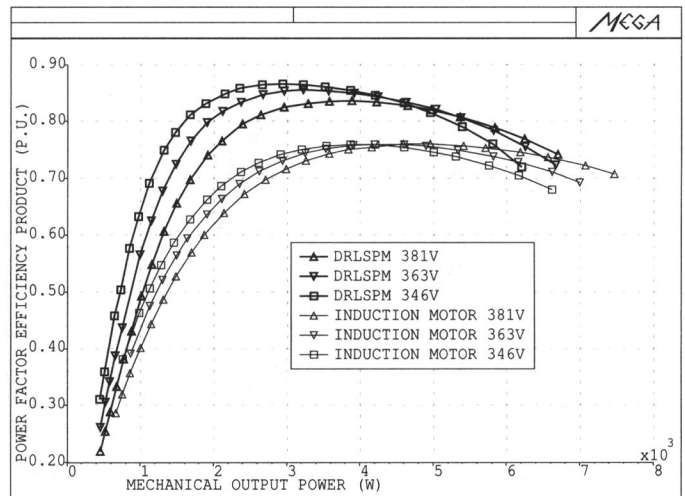

Fig. 11. Power factor efficiency product of the new machine compared with an EFF1 induction machine.

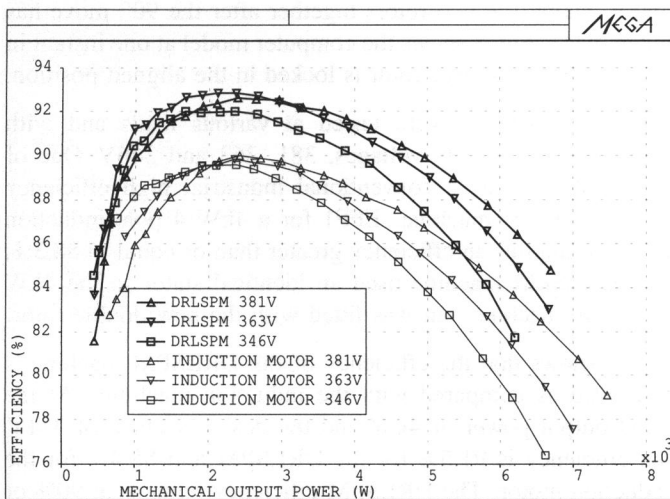

Fig. 9. Efficiency of the new machine compared with an EFF1 induction machine.

superior, 0.914 compared with 0.851 at 381V and 4kW for the induction motor. It will also be appreciated that the power factor of the DRLSPM machine is better than the induction machine in the range 1kW - 6kW.

Sometimes a motor is judged by the product of power factor and efficiency, this is shown on Fig. 11, the DRLSPM is 0.83 and the induction motor is 0.753 at 381V and 4kW.

When an induction machine runs on a lighter load than rated, the efficiency and particularly the power factor is reduced. This effect can be seen on Fig. 9, for the induction motor at 4kW the efficiency is 88.4% and at 1kW the efficiency is 85.9% at 381V.

Methods for improving the efficiency and power factor of lightly loaded induction machines by reducing the supply voltage have previously been investigated by several groups. At 1kW the induction machine efficiency can be increased to

88.1% by decreasing the voltage to 346V. The reduced supply voltage results shown in Figs. 9 and 10 demonstrate that this scheme could also be applied to the new machine if desired. For instance, the 1kW results for the DRLSPM machine show that the 89.9% efficiency at 381V becomes 91.2% efficiency at 363V.

4 Conclusions

A new line start electric motor has been developed. The machine has a starting performance similar to that of a squirrel cage induction motor, has no need for power electronics, and has 30% less losses than one of the latest high efficiency EFF1 induction motors. The improvement over older or standard efficiency class induction motors would be even more significant. The efficiency of a power electronic drive for a 4kW motor is at most around 96%. When this drive is used to supply a conventional PM machine of around 93% efficiency, the overall efficiency of the system is only $0.96 \times 0.93 = 89\%$. The new machine prototype has demonstrated 93% efficiency and so has a 4% efficiency advantage. The new machine would therefore be a good choice in an application where a fixed speed drive is required. As more is learned about optimising the design of the new machine, greater improvement in performance should be possible.

5 Acknowledgements

The authors would like to acknowledge an EPSRC grant for this project. Thanks are also due to Prof Steve Williamson and Dr Sandy Smith, now at Manchester University, who helped us to obtain funding for the project while they were working in industry.

References

- [1] ETSU Harwell and Doug Warne REMACS. "Energy savings with motors and drives Good practice guide 2 ". *Best Practice Programme, Dept of Environment, Transport and Regions*, March 1998.
- [2] R.M.Saunders and R.H.Weakley. *AIEE Trans.*, 70(Pt II):1578–1581, 1951.
- [3] K.J.Binns, W.R.Barnard, and M.A.Jabbar. *Proc IEE*, 125(3):203–208, March 1978.