



Citation for published version:

Plummer, AR 2009, 'Highly dynamic servohydraulic motion control' Paper presented at International Conference on Fluid Power Transmission and Control: ICFP 2009, Hangzhou, China, 7/04/09 - 10/04/09, pp. 23-27.

Publication date:
2009

[Link to publication](#)

University of Bath

General rights

Copyright and moral rights for the publications made accessible in the public portal are retained by the authors and/or other copyright owners and it is a condition of accessing publications that users recognise and abide by the legal requirements associated with these rights.

Take down policy

If you believe that this document breaches copyright please contact us providing details, and we will remove access to the work immediately and investigate your claim.

Highly dynamic servohydraulic motion control

A R Plummer

Centre for Power Transmission and Motion Control, University of Bath, UK

A.R.Plummer@Bath.ac.uk

Abstract

Non-linear model-based controller design enables high bandwidth motion control of servohydraulically actuated systems. In this paper, results are presented for three example systems from the structural testing industry: a pedestrian impact test system, a crash testing catapult, and an earthquake simulation table. An important element of such control systems is the provision of high accuracy, low noise feedback signals (for example combining position and acceleration measurements to improve motion estimation). Closed loop bandwidth well above the hydraulic resonant frequency is achievable.

1 Introduction

Servocontrolled hydraulic actuators have a wide performance envelope, thus providing the opportunity to control motion at high frequency (typically hundreds of hertz). This is in contrast to electromagnetic actuators, for which gearing is normally required to provide sufficient force or torque output, and the resulting effective inertia of the actuator limits the high frequency motion to an unusably small amplitude. In servohydraulic position control, conventional control methods (such as proportional-integral) are adequate for some applications. However, more sophisticated control algorithms are required if the full high-frequency potential is to be realised.

This paper gives three examples of model-based control used to give an extended control bandwidth, enabling much improved tracking response and disturbance rejection. All three applications are from the structural testing industry; one requires velocity control, and two require acceleration control. The only significant difference between controlling position and controlling velocity or acceleration, is that in the latter cases the requirement tends to be for accurate command following up to higher frequency.

2 Example: launcher for pedestrian impact testing

The automotive regulatory authorities in many countries require new vehicle designs to have proven standards of safety for pedestrian impact. This includes leg impact for the front of the vehicle, and head impact on the bonnet. In order to test for safety, an instrumented dummy headform or legform is fired at the vehicle at a prescribed location and velocity. The deceleration of the dummy body part (impactor) is monitored to ensure it is within the required limits.

The impactor is required to strike the vehicle at high velocity (e.g. 50km/h, which is 13.9m/s), with a desired accuracy of 0.1m/s. In the past, in order to approach this accuracy the launch mechanism which fires the impactor must be calibrated for every target velocity, angle of launch, and impactor mass. This is a laborious trial-and-error process, and accuracy is susceptible to other parameter variations (e.g. oil temperature).

A launcher using a servocontrolled hydraulic actuator mounted in a recoil mechanism, and positioned using a commercial robot, is shown in Fig. 1. In order to accelerate the impactor using a small stroke actuator the acceleration period is short – between 10ms and 100ms.

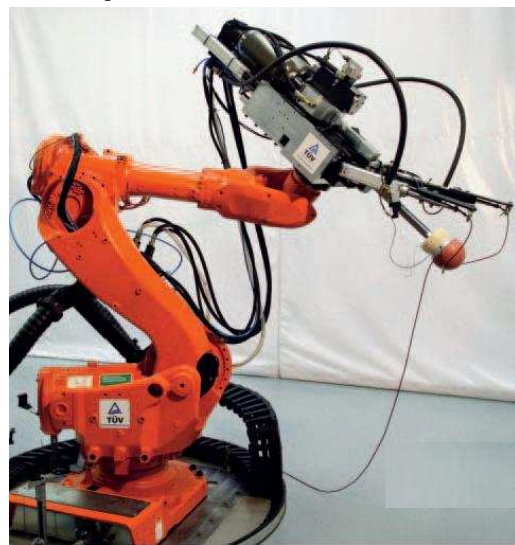

Fig. 1: Pedestrian impact test launcher

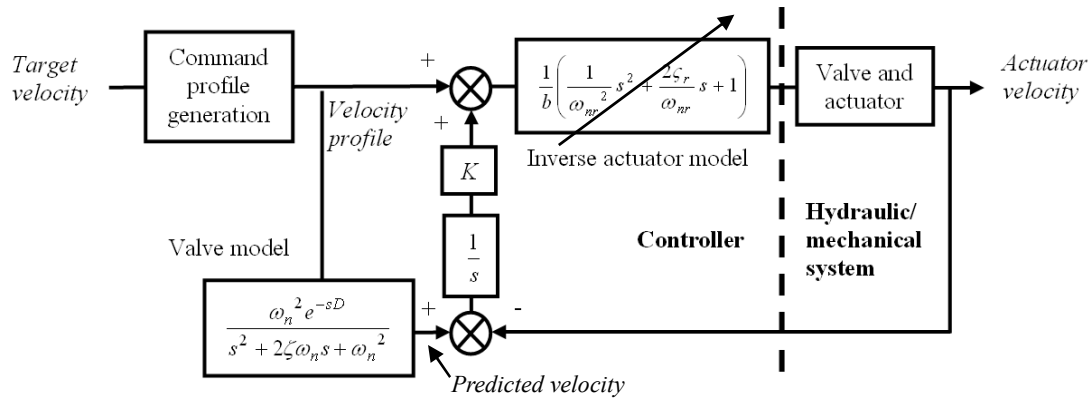

Fig. 2: Launcher control system [1]

The high bandwidth controller shown in Fig. 2 uses an inverse actuator model to compensate for the hydraulic resonance, allowing the closed loop bandwidth to extend beyond the hydraulic resonant frequency. This inverse model also compensates for the non-linear pressure-flow characteristic of the valve – it does this by varying gain parameter b as a function of the estimated valve pressure drop. The residual dynamics of the combined plant and inverse actuator model are the valve dynamics. Thus even without feedback, the direct command signal feedforward path gives an expected velocity response equal to the valve dynamic response. Using a valve dynamic model, the controller compares the predicted and actual response, using the difference as a feedback signal. Such an arrangement can be thought of as a disturbance observer, as the correction from closing the loop is zero if there are no disturbances and no modelling errors. The integrator in the closed loop path equates to proportional position control; such a simple scheme is effective as the residual valve dynamics are benign (well damped).

A very accurate velocity signal is required, as the signal is integrated and differentiated, the inverse actuator model effectively using position, velocity and acceleration. In reality the velocity signal is generated from a combination of measured position (differentiated and low pass filtered) and acceleration (integrated and high pass filtered), as shown in Fig. 3. Complementary low and high pass filters are used so that when the two velocity components are summed there is no amplitude or phase distortion of the resulting velocity estimate. The exact choice of filters is very important to ensure that the effect of noise and calibration errors is

minimized. The optimal calculation of filters is described in [2].

Fig. 4 shows an example time response for a legform launcher using this controller, with a terminal command velocity of 11.1m/s. The launcher has a 350mm stroke actuator, 20kN stall force, and a 3-stage valve rated at 630 L/min.

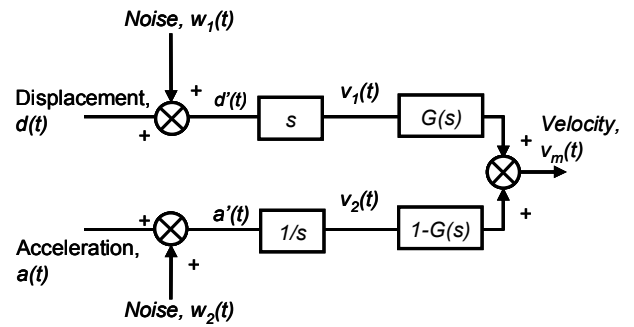

Fig. 3: Velocity estimator [2]

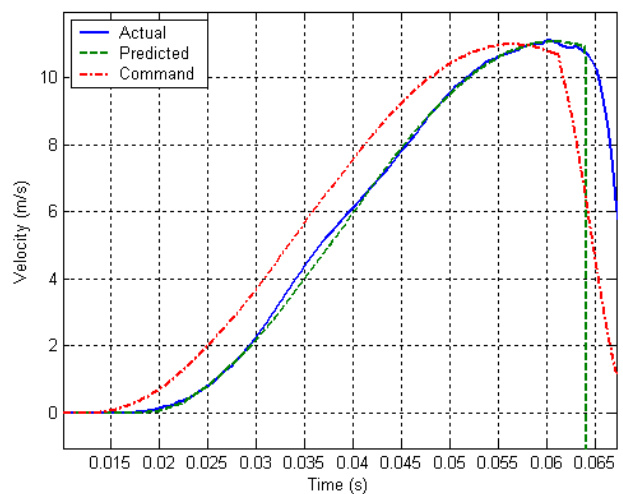

Fig. 4: Velocity response (11.1m/s target)

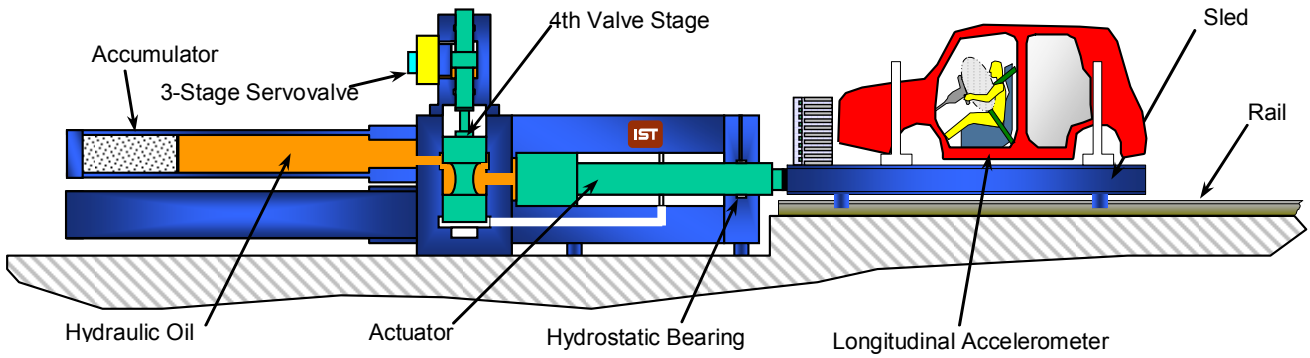

Fig. 5: Crash test catapult [3]

3 Example: crash testing catapult

A common method for evaluating the crashworthiness of a vehicle is a full-scale crash test against a barrier. However, for the development of passenger protection systems it is more convenient to perform non-destructive tests in the laboratory. So for a frontal crash, rearward vehicle acceleration is measured during a barrier crash test, and a simulator rig is used to reproduce this acceleration on a vehicle in the laboratory. The most accurate crash simulators consist of the vehicle buck (just the body structure and required passenger compartment fittings) mounted on a sledge which runs on rails; see Fig. 5. A hydraulic catapult provides the acceleration force. The catapult is a large, high speed, hydraulic actuator which accelerates the vehicle backwards from rest.

Iterative control is used to determine a command signal which gives the required acceleration profile. In other words, an approximate inverse model of the catapult dynamics is used to predict the required command signal, and this signal is tried out; any error between the target and actual acceleration profile is then used to modify the drive signal, again using the inverse model. The process, illustrated in Fig. 6, is repeated until the required accuracy is achieved. This approach is only acceptable as in this case it is possible to do a number of ‘dummy runs’ without damaging the specimen. By implementing the inverse model off-line as opposed to part of a closed-loop system, phase-compensated filters can be used, enabling a higher order inverse model to be feasible (i.e. with higher derivatives). Thus unlike the previous impact test example, both valve and actuator models can be inverted.

Until the work described in [3], linear frequency

domain models were typically used for this iterative control process. However, in that paper it was shown that non-linear physically-based modelling in the time domain gives significant reductions in the number of iterations required. Fig. 7 shows a close match between actual and target accelerations, which was achieved after an initial run and two subsequent iterations. These results are for a 2.5MN stall force actuator, driven by a 4-stage valve with 140 000 L/min maximum flowrate, giving a 25m/s peak velocity.

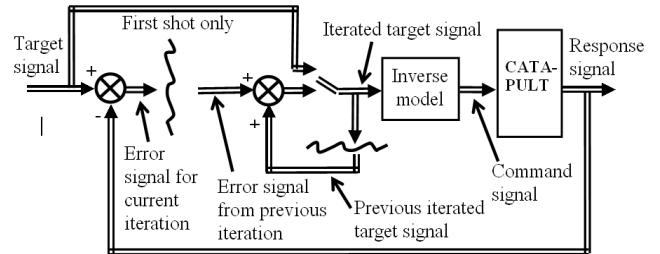

Fig. 6: Iterative control process

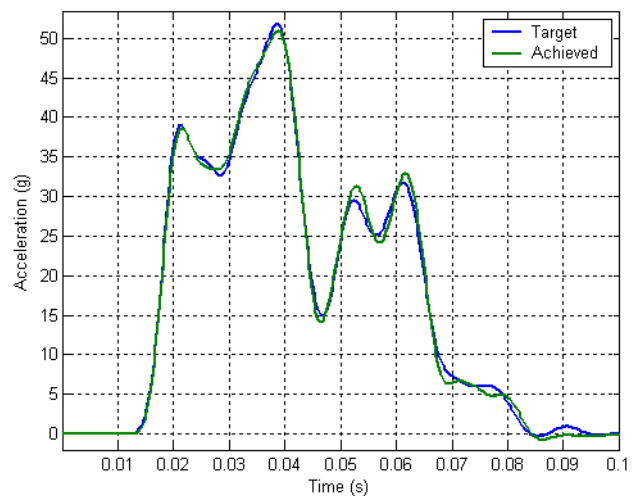

Fig. 7: Replicating a crash acceleration profile

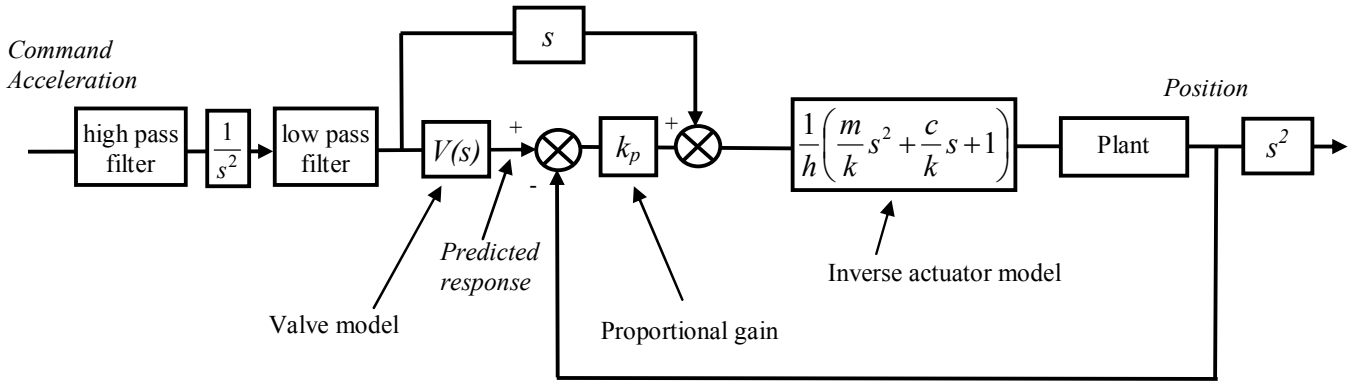

Fig. 8: Controller for single-axis earthquake simulation table [4]

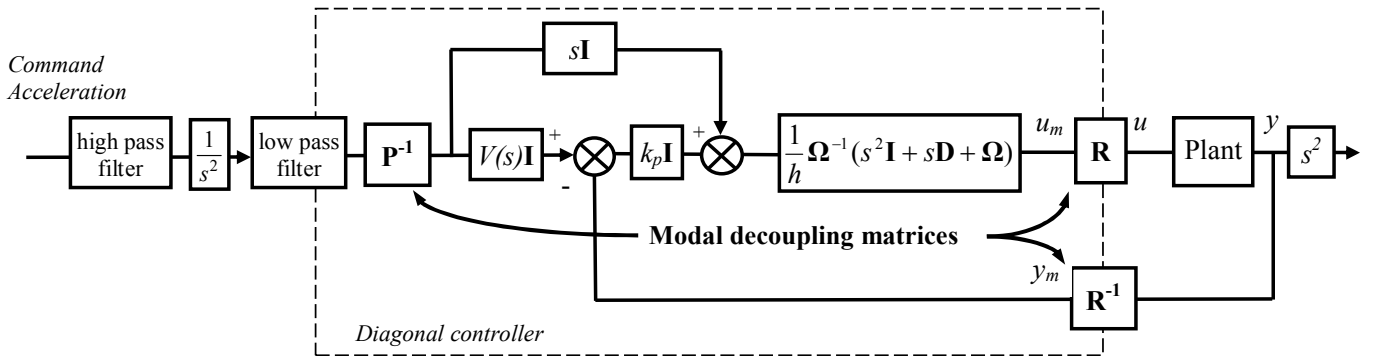

Fig. 9: Controller for 6 degree-of-freedom earthquake simulation table [4]

4 Example: earthquake simulation table

Large servohydraulic shaker tables are used for earthquake simulation, often replicating acceleration profiles measured in real earthquakes. The control of such systems is challenging, as often test frequencies are significantly higher than the hydraulic resonant frequencies of the system. Further, a high centre of gravity and large horizontal accelerations may be encountered, generating a large overturning moment which tends to cause the table to pitch. Many of the test structures suffer damage during testing, so it is not possible to use multiple trials and iterative control to converge on the required acceleration profile.

Fig. 8 shows a control scheme for a single-axis shaker table. Like the first example, this uses an inverse actuator model, a forward valve model, and requires a combination of position and acceleration measurements to provide accurate motion feedback. In reality, most shaker tables are multi-axis, many having six degrees-of-freedom, and a multivariable version of the controller is required (Fig. 9). Such a controller is described in [4], which uses modal decomposition to generate decoupled control axes for each hydraulic

resonance. A limitation of the method is the approximation of the test structure as a rigid mass. The closed loop response for acceleration in one horizontal axis is shown in Figures 10 and 11; these are for a proportional-integral controller and the new model-based controller respectively. The ability to reject unwanted pitching motion is also greatly improved. These responses were obtained for the 5mx5m 20-tonne table shown in Fig.12, which has a dominant horizontal hydraulic resonant frequency of about 15Hz.

5 Conclusions

Through three examples, the effectiveness of using model-based control for high performance servohydraulic motion control has been demonstrated. In the first and third examples (the pedestrian impact launcher and the earthquake simulation table), high closed loop bandwidth is achieved. In the crash test catapult example, the task is simplified by the ability to do multiple trials and hence iterate to reduce tracking error; as a result the accuracy expected is particularly high. In all three examples the ability to control high frequency motion allows very high velocities and accelerations to be reproduced with

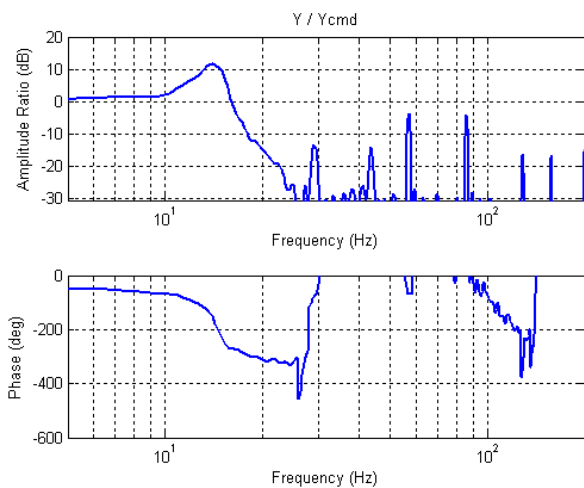

Fig. 10: Horizontal acceleration frequency response, PI controller

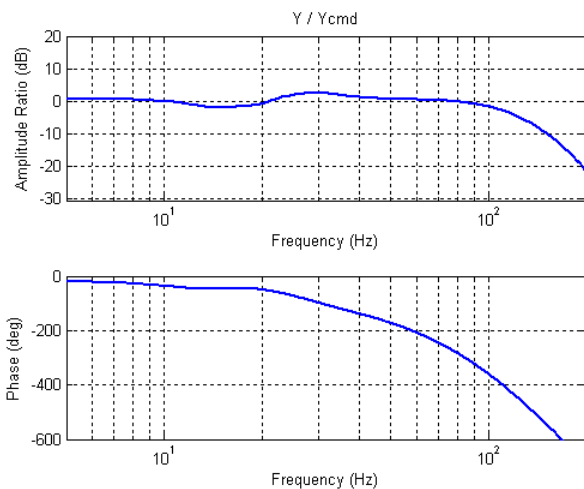

Fig. 11: Horizontal acceleration frequency response, model-based controller

relatively short stroke actuators. No technology, other than valve-controlled hydraulic actuators, can produce anywhere close to the dynamic performance shown for the three applications in this paper. For the first two examples, in which the test requires just one extension of the actuator, mechanically-braked pneumatic actuators can be used, but accuracy and reliability are not as good.

Model-based control requires both a good knowledge of the key characteristics that must be included in the model, and the parameter values for the particular system in question. Parameter values can be determined from a combination of known component data, and estimation from experimental data. Modelling of an earthquake simulation table is described in detail in [5]. A difficulty often encountered in testing systems which prevents the control methods described here from being adopted is when unknown specimen dynamics greatly influence the system. In this case, a greater reliance on iterative

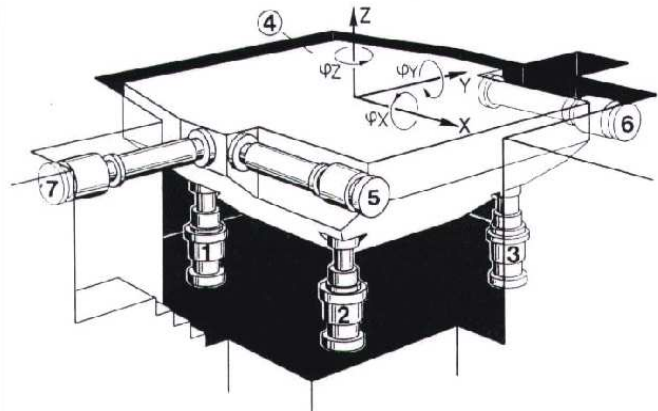

Fig. 12: 5m x 5m shaker table

control (based on identified non-parametric system models), or sometimes adaptive control is required; a variety of alternative methods is reviewed in [6].

Acknowledgement

Much of the work reported in this paper was undertaken while the author was an employee of Instron Ltd.. Instron is thanked for granting permission to publish relevant data.

References

- [1] Plummer, A.R. Closed-loop velocity control for an electrohydraulic impact test system. **PTMC 2005 Bath**, September 2005, 75-90.
- [2] Plummer, A R. Optimal complementary filters and their application in motion measurement **Proc. Instn. Mech. Engrs, Part I, Journal of Systems and Control Engineering**, 220(6), 489-508, 2006.
- [3] Plummer, A R Iterative acceleration control of a hydraulic actuator for vehicle crash simulation. **PTMC 2002**, Bath, September 2002, 191-202.
- [4] Plummer A R. High bandwidth motion control for multi-axis servohydraulic mechanisms. **ASME International Mechanical Engineering Congress and Exposition, IMECE2007**. (article number IMECE2007-41240). Seattle, USA, November 2007.
- [5] Plummer A R. A Detailed Dynamic Model of a Six-axis Shaking Table. **Journal of Earthquake Engineering**. 12 (4). pp. 631-662., 2008.
- [6] Plummer, A.R. Control techniques for structural testing: a review **Proc. Instn. Mech. Engrs, Part I, Journal of Systems and Control Engineering**, 221(2),139-169, 2007.