



Citation for published version:

Muelaner, JE, Wang, Z & Maropoulos, PG 2010, 'Concepts for and Analysis of a High accuracy and High Capacity (HAHC) Aerospace Robot' Paper presented at The 21st International Computer-Aided Production Engineering Conference: CAPE 2010, Edinburgh, 13/04/10 - 14/04/10, .

Publication date:
2010

Document Version
Peer reviewed version

[Link to publication](#)

University of Bath

General rights

Copyright and moral rights for the publications made accessible in the public portal are retained by the authors and/or other copyright owners and it is a condition of accessing publications that users recognise and abide by the legal requirements associated with these rights.

Take down policy

If you believe that this document breaches copyright please contact us providing details, and we will remove access to the work immediately and investigate your claim.

CONCEPTS FOR AND ANALYSIS OF A HIGH ACCURACY AND HIGH CAPACITY (HAHC) AEROSPACE ROBOT

J. E. Muelaner, Z. Wang, P. G. Maropoulos

Department of Mechanical Engineering, The University of Bath, Bath, ,
United Kingdom, email: j.e.muelaner@bath.ac.uk

Abstract: Case study work carried out within the aerospace sector has highlighted the requirement for highly accurate and high capacity robots in aerospace assembly, literature supports this observation. This paper presents the generic capabilities of such a system. These include the ability to rapidly locate its-self within a large measurement volume using supplementary laser metrology systems, to carry out detailed inspection beyond the line of sight, and to accurately locate parts, drill holes and fettle interfaces. The concept presented is for a standardised robot which will provide a flexible automation system able to carry out a full range of operations required in the assembly of large aerospace structures.

Keywords: Aerospace, Automation, Metrology

Introduction

The assembly of large aerospace structures relies on monolithic jigs and high levels of manually intensive reworking, fettling and drilling operations. The fundamental process is to bring together large flexible components and secure them to a rigid jig which controls the shape of the emerging structure. Interface gaps are detected through the use of slip gauges and other manual inspection techniques. Components are shimmed or fettled to maintain interface tolerances. Holes are then drilled through the components and they are fastened together. This has been summarized as, “Place, clamp, fasten and release” [1]. A generic aerospace assembly is shown in more detail in Figure 1.

Assembly may account for as much as 40% of the total cost of manufacturing an airframe due largely to the labour and quality issues inherent to drilling thousands of holes per aircraft [2]. Approximately 5% of the total manufacturing cost of an aircraft [3] or 10% of the airframe [4] is related to the use of fixed tooling while reworking also represents a significant proportion of the total cost of aircraft [5].

Some progress has been made in the automation of hole drilling and fastener placement [6-8]. However, due to the difficulties in controlling tool placements at large scales, low production volume and high complexity, automation within aerospace remains a considerable distance behind automotive production. Current automation solutions also rely on very capital intensive bespoke machines, often large gantry based systems. There is therefore a strong interest within industry in replacing these bespoke machines with flexible and low cost industrial robots.

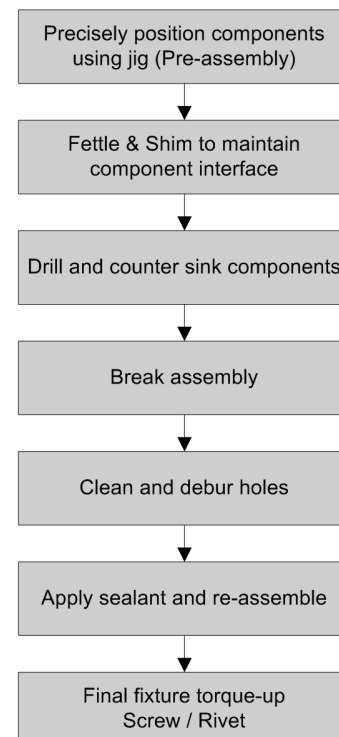

Figure 1: Generic Aerospace Assembly Process [9]

The adoption of flexible automation systems has the potential to reduce the expensive requirement for skilled labour working within a potentially dangerous environment. Use of these automation systems is likely to improve quality and greatly reduce the complexity of jigs required to accurately position holes and components on an assembly. Ultimately a jigless manufacturing system would require tooling only to position components with all tool placements made by flexible automation. This greatly simplified tooling is also more likely to be practical to construct using reconfigurable components. The tooling costs would therefore be further reduced.

There are numerous examples of the use of industrial robots in aerospace processes. For example component location and riveting [10], positioning ribs to an accuracy of ± 0.5 mm under guidance from a laser tracker [11], composite dry layup [12] and tape laying [13].

Studies have been carried out to determine the accuracy and repeatability of industrial robots, for example focusing on the ability to program robots off line [14] and the suitability of industrial robots for drilling in aerospace assemblies [15]. These studies have shown that without an external metrology system providing positional feedback the absolute accuracy of industrial robots is of the order of 1 mm which is not sufficient for aerospace processes.

A number of attempts to improve the performance of industrial robots have utilized external optical metrology systems. These include Adaptive Robotic Control [15] which utilizes a photogrammetry system and Leica T-Robot [16] which uses a hybrid laser-tracker and photogrammetry system.

One disadvantage of these systems is the requirement for lines of sight. This complicates the off-line programming of operations and puts additional limitations on which operations are possible.

Perhaps a more fundamental disadvantage is that the external metrology system only provides accurate feedback on the 6 degrees of freedom DOF position of the end effector. Providing feedback in this way makes it difficult to fully integrate the feedback with the robot's controller in real time to give high accuracy and full speed movements. This is in contrast to a fully metrology integrated robot, such as that proposed below, in which case the metrology system provides accurate feedback on the angular rotations of each articulation in the robot structure.

If the robot is supplied with real time information on the angular rotation of each joint then it is likely to be able to achieve high accuracy in real time with the robot operating at full speed. This will allow operations to be carried out which are not possible without real time high accuracy such as fettling high quality surfaces.

Generic Capabilities of a HAHC Robot

This paper presents a conceptual design for a high accuracy and high capacity robot in which accurate feedback is provided to the robot controller giving not just the 6 DOF position of the end effector but also the angular rotations of each articulation in the robot structure. The design and analysis of the system are presented in the following sections. This section describes the generic capabilities of such a system, these include the ability to rapidly locate its-self within a large measurement volume using supplementary laser metrology systems, to carry out detailed inspection beyond the line of sight, and to accurately locate parts, drill holes and fettle interfaces. Importantly the system also has a large working envelope and wide range of motion, in common with other serial link industrial robots. Parallel kinematic machines (PKM) and conventional machine tools have many of the advantages described but lack the working volume in relation to machine size and the flexibility of operation. Some current serial robotic systems possess some of the capabilities described although there are currently no systems which possess all of these in a single system. In particular the ability to have high accuracy combined with high load carrying capacity is not currently possible with commercial robot systems. The concept presented is for a standardised robot which will provide a flexible automation system able to carry out a full range of operations required in the assembly of large aerospace structures.

Ability to Rapidly Locate within a Large Measurement Volume

The high accuracy and high capacity (HAHC) robot may be driven between fixed locations within the production environment using some form of lower accuracy automation such as an automated guided vehicle (AGV) or gantry system. Some method of accurately locating the HAHC robot in its fixed position before it carries out operations is required if high accuracy is to be achieved with respect to some global reference system.

Methods of locating articulated arm coordinate measuring machines (CMM's) within a larger measurement volume are commercially available. For example the FARO TrackArm [17] system uses a laser tracker to locate the CMM in 6 DOF. The method is to manually point the laser tracker at a retroreflector located on the final link of the CMM arm, a measurement is then taken by both the laser tracker and the CMM arm. The arm is manually moved into another pose while the laser tracker tracks the retroreflector and a measurement is again taken by both instruments. This procedure is repeated at least three times. It is then possible to locate the base of the CMM arm in 6 DOF with respect to the laser tracker.

A similar procedure could be carried out to locate the HAHC robot using a laser tracker or other large volume measurement instrument. In this case however the position of the HAHC robot base will be approximately known based on the encoders within the lower accuracy automation system which has positioned it. It will therefore be possible to fully automate the location procedure. The robot end effector could be driven to a number of poses and the approximate position of a retroreflector built into the end effector sent wirelessly to a laser tracker controller. The laser tracker would then be able to carry out a spiral search to locate the retroreflector. This process is illustrated in Figure 2.

Further refinements to this process may involve including process models to automatically determine the robot path to avoid collisions with parts and tooling while moving the retroreflector into positions visible to the laser tracker. Another refinement could be the inclusion of additional measurement data to track the movement of the robot around the larger measurement volume, for example the AGV may be equipped with an inertial measurement unit or vision system to compensate for wheel slippage which would otherwise lead to significant errors in position.

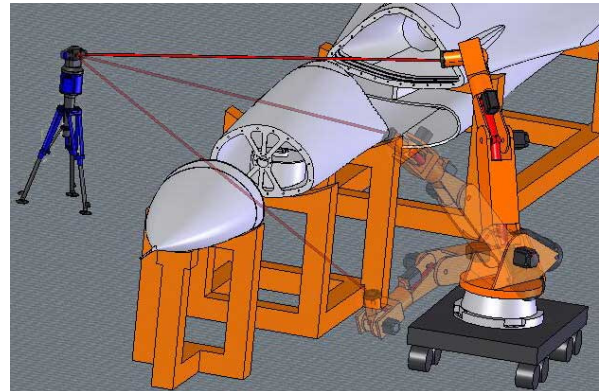

Figure 2: 6 DOF Location using a Laser Tracker

Ability to Carry out Inspection beyond Line of Sight

There are existing systems in which a robot is used to move a localized non-contact measurement system over an object, in these systems the position of the end effector is tracked in 6 DOF using an external metrology system such as photogrammetry [18] or a laser tracker [16]. This allows a number of separate localized measurements to be combined into a single global reference frame. The major

disadvantage to using an external metrology system is the requirement to maintain lines of sight between the end effector and the external system. This makes it very difficult to use such systems within confined spaces, for example a wing box, while automated inspections within such environments would be particularly beneficial.

A HAHC robot has the inherent capability to carry out such localized non-contact measurement since the position of the end effector is known to a high level of accuracy. Contact probing inspection using a touch trigger or scanning probe would also be possible.

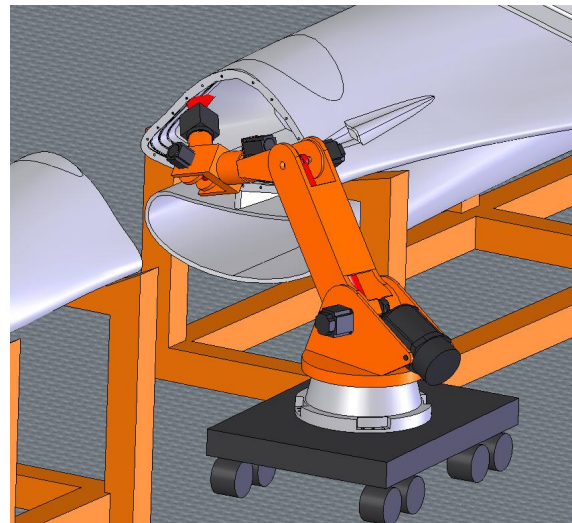

Figure 3: Image of line scanning inside an enclosure

Accurate Location of Parts, Drilling and Fetting

The ability to locate parts, drill holes and fettle interfaces to high levels of accuracy has to an extent been realized by robots operating with external metrology systems as discussed above. These systems are somewhat limited by line of sight restrictions as for the other processes described above.

A more fundamental limitation for machining operations is the lack of real time feedback on individual joint angles and the corresponding limitation on carrying out operations at full speed with high accuracy. By simultaneously providing independent metrology system feedback on all joint angles and the 6 DOF position of the end effector it would become possible to achieve high accuracy real time control.

Possible Concepts for a HAHC Robot

The requirements of a HAHC robot are that it must be capable of carrying out operations with an accuracy of less than 0.1 mm [15] while carrying loads and resisting process forces amounting to over 200 kg. Additionally the robot must be capable of a flexibility of movement and operating speeds comparable with current industrial robots. Two possible concepts are presented below.

Error Mapping Conventional Robot

It is generally understood that industrial robots have very good repeatability but poor accuracy. In fact this is also true of other machines such as conventional machine tools and coordinate measurement machines. In these cases error mapping is used to improve the accuracy. Provided that a machine is repeatable then it should be possible to correct for a lack of accuracy. It is however considerably more difficult to error map an industrial robot since it is not a simple cartesian machine. The first problem is that it is not possible to error map one axis at a time and then simply combine them, this problem is however solved through the use of a coordinate measurement machine to carry out error mapping, laser trackers are ideal for this application. The second problem is that there are multiple poses of the robot which can achieve the same end effector position. Where for a cartesian machine tool an error map might involve a 3 dimensional grid of points, for a serial robot a 5 dimensional array of positions would be required greatly increasing the time required for a calibration procedure.

The first stage in investigating the feasibility of error mapping a standard industrial robot is to establish what the true repeatability of the robot is over a time period sufficient to allow recalibration. Tests were carried out on a KUKA KR240 Robot as shown in Figure 4 using the following experimental procedure:

1. The Tool Centre Point (TCP) was specified as being the centre of a Spherically Mounted Retroreflector (SMR) and was calibrated using a laser tracker.
2. The KR240 robot was guided through a grid of 30 points (5x3x2), each roughly 500mm apart, utilizing a series of linear moves. The layout of the points is illustrated in Figure 5.
3. At each point, the arm dwells for 6 seconds; enough time for the arm to settle and for Spatial Analyzer (SA) software to automatically take a stable measurement using the laser tracker averaged over 4 seconds.
4. The process is repeated over a two hour period, each complete run through 30 points took approximately 4 minutes 25 seconds, yielding 27 trials.

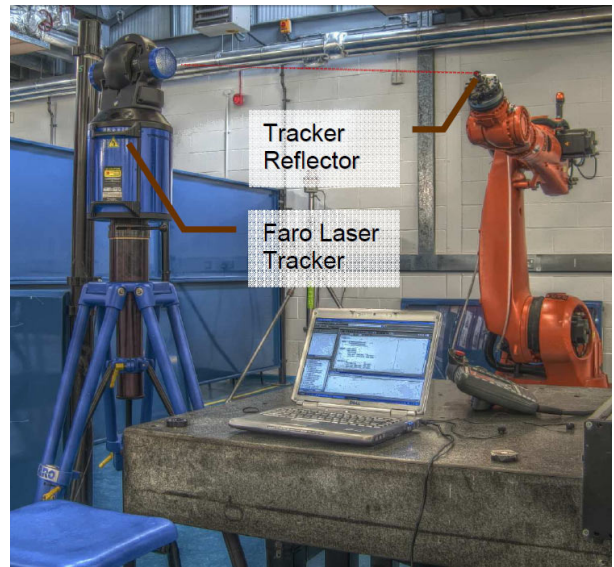

Figure 4: Experiment setup

Measurement uncertainties and possible sources of error in this procedure include:

- Flexibility within the SMR mount, which was fixed to the robot using adhesive.
- The Faro laser tracker used has a Maximum Permissible Error (MPE) of 10 – 15 μ m in ADM mode over the measurement range of 0.5 – 4.0m.
- Some of the points are measured with the laser hitting the SMR at very large angles which may increase the uncertainty of the laser tracker.

The collected data for each of the 30 points is plotted in Figure 5, with the drift over time from the first set of measurement exaggerated 2000 times for ease of visualization. Rather than a random scatter, the general trends of the drift are clearly discernable. Qualitatively, major direction of the drift seems to be away from the robot. The presence of clearly observable trends is encouraging as this would suggest that a very high grid point density would not be required for an error map.

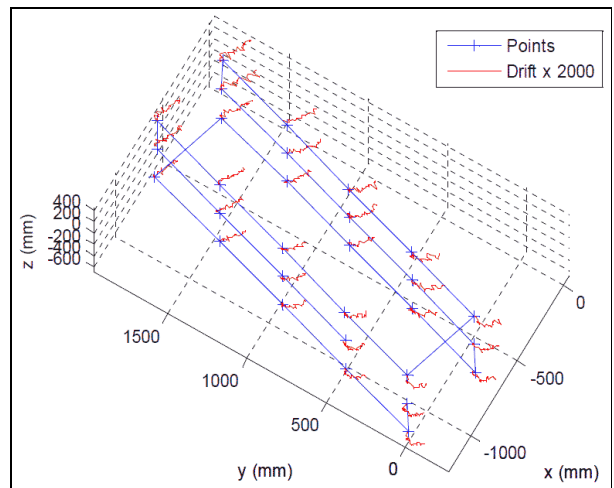

Figure 5: Drift in measured points

Figure 6 is a control chart showing the x-axis drift for each of the measured points across 27 trial runs. The largest drift over two hours was in the x-axis and was approximately 0.11mm. While this is below the manufacturer's specification for repeatability of ± 0.12 mm, the trend in the data is for the drift to continue if the experiment were carried out over a longer period and it is therefore unclear whether the robot would continue to drift beyond the manufacturers specification.

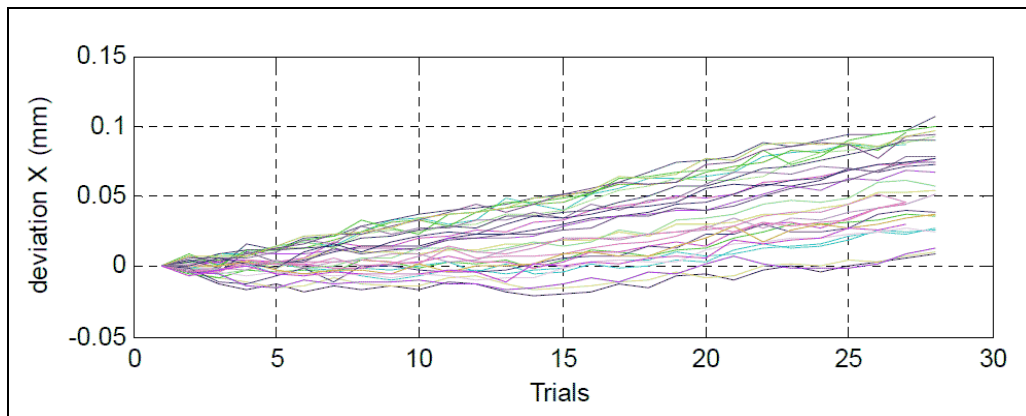

Figure 6: Control chart of X, Y and Z drift over trial number

In processes where a teach cycle is used to correct robot positions followed immediately by the robot carrying out the actual operation it is more relevant to determine the short term repeatability of the robot. If instead of considering the drift over all the trials, the deviation of the each point from its previous measurement is recorded then the short term repeatability is found to be of the order of 10 μ m.

It would appear that regular error mapping of a robot is impractical due to the complexity and time involved in error mapping a serial link device at a frequency of less than 2 hours. This approach has in fact been attempted by manufacturers with high-accuracy versions of standard robots being made available, these are not able to achieve better than 1 mm absolute accuracy.

Exoskeleton HAHC Robot

An alternative approach to achieving high accuracy from a high capacity robot suggested in this paper is to design a structure that bypasses the major sources of error in a conventional robot. Robots are fitted with encoders on the joints of the main robot structure; these are not able to provide accurate information on the end effector position due to factors such as thermal expansion and structural displacements. By placing an independent articulated structure inside the main driven and load carrying structure it should be possible to insulate this from the structural and thermal loads. The inner arm would be slaved to the outer structure so that it moves with it; the arrangement is illustrated in Figure 7.

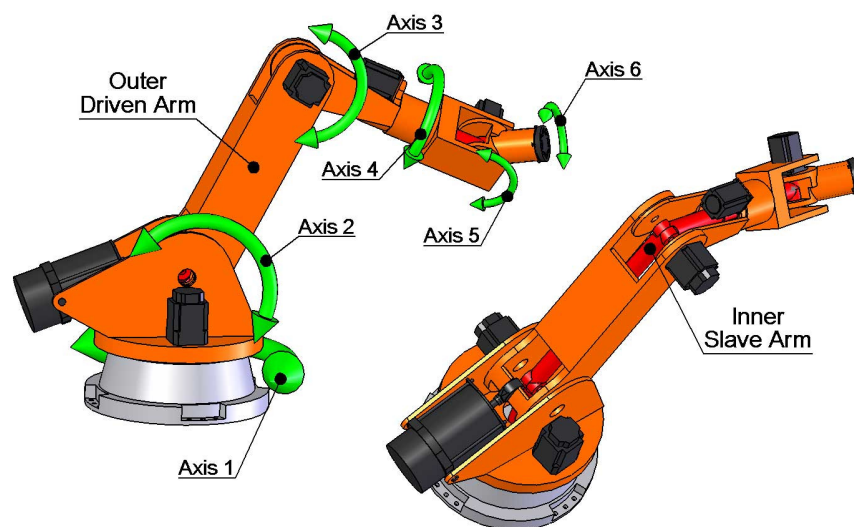

Figure 7: Concept Drawing of Exoskeleton HAHC Robot

Examples of such passive articulated structures with high accuracy encoders already exist in the form of articulated arm coordinate measuring machines (CMM's). These are able to achieve absolute accuracies of around 70 microns at scales similar to a high capacity industrial robot [19]. Similar performance could therefore be expected from an exoskeleton HAHC robot although lag in the control of the motors compared to the metrology system may lead to increased errors at higher speeds.

Conclusion

If a high accuracy and high capacity robot were available this would enable a wide range of new processes within aerospace assembly with the potential to dramatically reduce airframe assembly cost. Experimental work has shown that the most readily available solution, that of error mapping a conventional robot is unlikely to give the required performance due to limited system repeatability and the complexity involved in the calibration procedure. An alternative approach which has the potential to achieve high accuracies at high capacities is described. Further work would be required to simulate this type of system in order to predict actual performance.

Development of a commercial product with the described capabilities is likely to depend more on the perceived market demand for such systems. Although there is clearly a need for specialized robots within the aerospace sector the perception within the industrial robot industry is currently that the demand is for an insufficient volume of robots to warrant production of specialized products.

Acknowledgments

The authors wish to thank ABB Robotics for access to equipment and technical support. This research has been carried out as part of the IdMRC at the Department of Mechanical Engineering of the University of Bath, under EPSRC Grants No. EP/E002617/1 and EP/E00184X/1.

References

- [1] Pickett, N., S. Eastwood, P. Webb, N. Gindy, D. Vaughan, and J. Moore. *A Framework to Support Component Design in Jigless Manufacturing*. in *Aerospace Manufacturing Technology Conference & Exposition*. 1999. Bellevue, Washington
- [2] Bullen, G.N., *The Mechanization / Automation of Major Aircraft Assembly Tools*. Production and Inventory Management Journal, 1997: p. 84-87.
- [3] Rooks, B., *Assembly in aerospace features at IEE seminar*. Assembly Automation, 2005. **25**(2): p. 108-111.
- [4] Burley, G., R. Odi, S. Naing, A. Williamson, and J. Corbett. *Jigless Aerospace Manufacture - The Enabling Technologies*. in *Aerospace Manufacturing Technology Conference & Exposition*. 1999. Bellevue, Washington: Society of Automotive Engineers
- [5] Curran, R., A. Kundu, S. Raghunathan, and R. McFadden, *Impact of aerodynamic surface tolerance on aircraft cost driver*. Proc Instn Mech Engrs Part G: J Aerospace Engineering, 2002. **216**: p. 29-39.
- [6] Hogan, S., J. Hartmann, B. Thayer, J. Brown, I. Moore, J. Rowe, and M. Burrows. *Automated Wing Drilling System for the A380-GRAWDE*. 2003: SAE
- [7] Calawa, R., S. Smith, I. Moore, and T. Jackson. *HAWDE Five Axis Wing Surface Drilling Machine*. 2004: SAE
- [8] Hempstead, B., B. Thayer, and S. Williams, *Composite Automatic Wing Drilling Equipment (CAWDE)*. 2006, SAE.
- [9] Muelaner, J.E. and P.G. Maropoulos. *Large Scale Metrology in Aerospace Assembly*. in *5th International Conference on Digital Enterprise Technology*. 2008. Nantes, France
- [10] Webb, P., S. Eastwood, N. Jayaweera, and Y. Chen, *Automated aerostructure assembly*. Industrial Robot: An International Journal, 2005. **32**(5): p. 383-387.
- [11] Rooks, B., *Automatic wing box assembly developments*. Industrial Robot: An International Journal, 2001. **28**(4): p. 297-301.

- [12] Zhang, Z. and M. Sarhadi, *Integrated CAD/CAM system for automated composite manufacture*. Journal of Materials Processing Technology, 1996. **61**(1-2): p. 104-109.
- [13] Kimball, K. and D. Hauber. *In-situ Consolidated Thermoplastic Composite Aerospace Structures*. in *SEICO 08*. 2008. Paris
- [14] Young, K. and C.G. Pickin, *Accuracy assessment of the modern industrial robot*. Industrial Robot: An International Journal, 2000. **27**(6): p. 427-436.
- [15] Summers, M. *Robot Capability Test and Development of Industrial Robot Positioning System for the Aerospace Industry*. in *AeroTech Congress & Exhibition*. 2005. Grapevine, Texas: SAE International
- [16] Leica, *PCMM System Specifications: Leica Absolute Tracker and Leica T-Products*. 2008.
- [17] FARO. *New TrackArm Extends "Measure Anywhere" Capability*. 2006 [cited 2009 17th March]; Available from: <http://www.faro.com/content.aspx?ct=kr&content=news&item=117&tab=2>.
- [18] Metris, *K-Robot*. 2009.
- [19] FARO, *Quantum FaroArm Techsheet*. 2008.