

**Serological and molecular characterization
of begomoviruses infecting cassava
(*Manihot esculenta* Crantz) in Africa**

Vom Fachbereich Gartenbau
der Universität Hannover
zur Erlangung
des akademischen Grades eines

Doktors der Gartenbauwissenschaften

- Dr. rer. hort. -

Genehmigte Dissertation von
Were Hassan Karakacha, BSc, MSc, Nairobi
geboren am 30.11.1967 in Busia, Kenia

vorgelegt im
Oktober 2001

Referent:

Prof. Dr. Edgar Maiß

Koreferent:

Prof. Dr. Günter Adam

Tag der Promotion: 21.12.2001

Eidesstattliche Erklärung

Hiermit versichere ich an Eides Statt, die vorliegende Arbeit selbstständig angefertigt und keine anderen als die angegebenen Quellen und Hilfsmittel benutzt zu haben, sowie die Arbeit noch nicht als Dissertation oder andere Prüfungsarbeit vorgelegt zu haben.

Hannover, den 17. Oktober 2001

Hassan Were Karakacha

Declaration

I hereby declare to have independently prepared this work with no other than the indicated sources and support. This composition has never been submitted elsewhere, as thesis or as any other examination paper.

Hannover, the 17. October 2001

Hassan Were Karakacha

To my family

ABSTRACT

The outbreak of an extremely severe form of cassava mosaic virus disease (CMD) that is sweeping across East and Central Africa and causing food shortages and consequently famine related deaths provided the incentive for this study. A diagnostic survey of the disease was conducted in cassava growing areas of Kenya, to identify the viruses associated with the disease and to study the presence of whitefly transmitted begomoviruses namely, *African cassava mosaic virus* (ACMV), *East African cassava mosaic virus* (EACMV) and the recombinant Uganda variant virus (UgV). This “new” UgV virus was of particular interest, since it was this virus type which was found persistently associated with the severe form of CMD. In addition, cassava samples were obtained from many other cassava growing regions in sub-Saharan Africa, to gain an overview of the identities and distribution of viruses causing CMD in Africa.

A total of 230 leaf samples and 185 hardwood stem cuttings were collected and analyzed. Disease severity data were collected and viruses were typed and characterized using ELISA and PCR. In Kenya, the disease incidence was highest (80-100%) in the western regions neighbouring Uganda and lowest (25-50%) at the coastal region of the country. In Western and Nyanza provinces, 52.2% of the samples tested were infected with UgV, 21.7% with ACMV and 17.4% with mixed infections of ACMV and UgV. All samples from the coast province were infected with EACMV only and no other begomovirus was found in this cassava growing region. However, in about 15% of the cassava samples, filamentous viruses were found, which were not detected in samples from other regions.

When cassava samples obtained from other major cassava cultivating regions of Africa were analyzed, ACMV was the only virus found in West Africa, with very few exceptions of EACMV that was detected in samples from Nigeria and Guinea. Outside Kenya, UgV was detected in samples from Uganda and the Democratic Republic of the Congo, D.R.C. This indicates that UgV is rapidly spreading into western regions of the continent thereby endangering the cassava production in West Africa.

Symptoms of begomovirus diseases in cassava were indistinguishable, however, the most distinct and outstanding feature of UgV infections was the almost

complete reduction of tuber formation and often very severe foliar symptoms which were also induced by double infections with both ACMV and UgV. Symptoms in *Nicotiana benthamiana* plants infected with an ACMV isolate from Kenya, ACMV-KE, could be distinguished from an ACMV isolate from Nigeria, ACMV-NG, by the bright yellow blotches which are typically induced by ACMV-KE on the inoculated leaves. Symptoms induced by EACMV in *N. benthamiana* were similar to those induced by UgV and considerably milder than those induced by either ACMV-KE or ACMV-NG. Severely affected *N. benthamiana* plants were mostly doubly infected with ACMV and UgV.

The complete nucleotide (nt) sequences of DNA-A (2781 – 2801 nt) and DNA-B (2724 - 2726 nt) genomic components of selected virus types were obtained. The sequences of DNA-A genomic components shared a high identity with those of either ACMV, EACMV, or UgV already described, implying that DNA-A was highly conserved among the different cassava begomoviruses. The “new”, recombinant UgV was verified by the characteristic and almost invariable recombination sequences present in the coat protein genes of all isolates sequenced. This sequence originates from ACMV, while all other DNA-A regions reflect typical sequences of EACMV. Since the recombination comprised only a short segment of the coat protein, the virus was verified as a strain of EACMV and hence named EACMV-UgV, which is used synonymously with UgV.

Analysis of the DNA-B sequence of a Kenyan isolate of EACMV-UgV revealed a DNA-B component identical to those of ACMV isolates described. Furthermore, for all virus isolates with characteristic EACMV-UgV-like DNA-A genomic components, only ACMV-like DNA-B genomic components were amplified.

Full-length clones of DNA-A and DNA-B genomic components were constructed and attempts were made to introduce homologous (ACMV/ACMV) and heterologous (EACMV/ACMV; EACMV-UgV/ACMV) combinations of DNA-A and DNA-B genomic components into *N. benthamiana* plants. Inoculation of linearized constructs containing full-length clones or of partial head-to-tail dimers of DNA-A and DNA-B genomic components resulted in the introduction of DNA-A genomic components into the host plant. However, in heterologous combinations, only DNA-A genomic component was detected in inoculated plants which showed weak

attenuated symptoms. Only homologous combinations of ACMV DNA-A and DNA-B components resulted in an infection with a fully viable virus and showing typical CMD symptoms. This indicated that EACMV-UgV probably has a unique DNA-B genomic component which was, however, not found in this study.

Breeding cassava for resistance against begomoviruses and producing virus free planting material is problematic mainly due to the difficulties encountered by plant breeders and seed producers in selecting resistant varieties and particularly clean planting material. Robust, reliable and sensitive detection methods would present a substantial improvement in virus indexing schemes. Serological and nucleic acid based diagnostic techniques were developed and evaluated for their reliability and sensitivity in detecting and differentiating begomoviruses infecting cassava. Monoclonal antibodies (MAbs) used in TAS-ELISA provide a useful means to determine the virus status in cassava. When a definite determination of mixed infections is required, or the virus(es) in question have to be unequivocally identified, only a PCR approach will provide a clear differentiation among the begomoviruses. For routine indexing in plant breeding and nurseries, as well as for virus detection and identification for quarantine purposes, appropriate methods are now available for diagnosing begomoviruses infecting cassava.

Keywords: Cassava mosaic begomoviruses, diagnosis, distribution

ZUSAMMENFASSUNG

Die epidemieartige Ausbreitung einer neuen Form der Cassava Mosaikerkrankung (CMD) über weite Teile der Maniokanbauggebiete von Ost- und Zentral Afrika, die mit Nahrungsmittelmangel und Hungersnot einhergeht, stellte den Anstoß für diese Studie dar.

Es wurde eine Feldstudie in den Maniok-Anbaugebieten Kenias durchgeführt, um die mit der Krankheit assoziierten Viren zu identifizieren und die durch die Weiße Fliege übertragenen Begomoviren, *African cassava mosaic virus* (ACMV), *East African cassava mosaic virus* (EACMV) und das rekombinante Virus, die Uganda Variante (UgV), zu untersuchen. Dieses „neue“ Virus war von besonderem Interesse, da dieser Virustyp grundsätzlich mit der neuartigen Cassava Mosaikerkrankung gefunden wurde. Um einen Überblick über die verschiedenen an CMD beteiligten Viren und deren Verteilung zu erhalten, wurden Proben aus vielen anderen Maniokanbaugebieten Sub-Sahara Afrikas erhalten und in die Untersuchung einbezogen.

230 Blattproben und 185 Stängelstecklinge wurden gesammelt und analysiert. Die Schwere der Symptome wurde bonitiert und die Viren mittels ELISA und PCR typisiert und charakterisiert. Das Vorkommen von CMD war in Kenia, in den westlichen Regionen an der Grenze zum benachbarten Uganda, mit 80-100% Befallshäufigkeit sehr hoch, während in den Küstengebieten nur etwa 25-50% Befall mit CMD festgestellt wurde. In den westlichen Regionen und den Nyanza Provinzen wurden in 52,2% aller Proben das rekombinante UgV gefunden, während in 21,7% aller Fälle ACMV und in 17,4% der Proben Mischinfektionen von ACMV und UgV festgestellt wurden. In der Küstenprovinz Kenias wurde ausschließlich EACMV und kein anderes Begomovirus gefunden. Allerdings wurden in dieser Maniokanbauregion auch in ungefähr 15% der Cassavaproben, fadenförmige, flexible Viren gefunden, die in Pflanzenproben anderer Regionen nicht zu finden waren.

Die Untersuchung von Cassavaproben aus anderen bedeutenden Anbaugebieten Afrikas ergab, dass in West Afrika, mit wenigen Ausnahmen in Nigeria und Guinea, wo auch EACMV gefunden wurde, einzig ACMV vorkommt. Außerhalb Kenias konnte das rekombinante UgV in Uganda und vor allem in der Demokratischen

Republik Kongos ermittelt werden. Damit ist die zunehmende westwärts gerichtete Ausbreitung des UgV bewiesen und der Maniokanbau in West Afrika besonders gefährdet.

Die Krankheitssymptome der bekannten Cassava Mosaikviren sind in Maniok nicht zu unterscheiden. Die herausragendste Eigenschaft der Virusinfektionen mit der neuen Variante UgV war jedoch die fast komplette Unterdrückung der Knollenbildung in Cassava, die bei Infektionen mit anderen Virustypen nicht beobachtet wurde. Für UgV wurden auch besonders schwere Blattsymptome beobachtet, jedoch war dieses oft auch ein Hinweis auf Mischinfektionen von ACMV und UgV. Symptome in *N. benthamiana* Pflanzen, die mit einem kenianischen ACMV Isolat, ACMV-KE, infiziert wurden, konnten von Infektionen mit einem nigerianischen Isolat, ACMV-NG, durch die auf den inokulierten Blättern sichtbaren chlorotischen Flecke, unterschieden werden. Symptome von EACMV Infektionen in *N. benthamiana* waren denen von UgV sehr ähnlich. Die Virusinfektion verlief jedoch beträchtlich milder als die Infektionen der ACMV Isolate. Sehr schwere Symptome waren bei ACMV/UgV Mischinfektionen in *N. benthamiana* zu beobachten.

Vollständige Nukleotidsequenzen (nt) von DNA-A (2781 - 2801 nt) und DNA-B (2724 - 2726 nt) ausgewählter Virustypen wurden erstellt. Die Sequenzen der DNA-A Komponenten wiesen eine hohe Identität zu bereits beschriebenen Sequenzen von ACMV, EACMV oder UgV auf. Dies zeigt, dass DNA-A Komponenten der verschiedenen Begomoviren sehr konservierte Sequenzen haben.

Das „neue“ rekombinante UgV wurde durch die nahezu invariable Rekombinationssequenz charakterisiert, die in den Hüllproteingenen aller sequenzierten Isolate vorhanden war. Diese Sequenz stammt von ACMV, während die restlichen DNA-A Bereiche typische EACMV Sequenzen darstellen. Da das Rekombinationsereignis nur ein kurzes Segment des Hüllproteins erfasst, wurde das Virus als Stamm des EACMV bestätigt und folglich als EACMV-UgV bezeichnet, das synonym zu UgV verwendet wird.

Die Analyse der DNA-B Nukleotidsequenz eines kenianischen EACMV-UgV Isolats, zeigte eine DNA-B Komponente, die ähnlich den für ACMV beschriebenen DNA-B Komponenten war. Für alle Virusisolate mit charakteristischen EACMV-UgV DNA-A

Komponenten, wurden nur DNA-B Genomkomponenten amplifiziert, die ACMV DNA-B ähnlich waren.

Es wurden vollständige Klone der DNA-A und DNA-B Genomkomponenten hergestellt und Versuche unternommen, *N. benthamiana* mit homologen (ACMV/ACMV) und heterologen (EACMV/ACMV; EACMV-UgV/ACMV) Kombinationen der Genomkomponenten zu infizieren. Die Inokulation mit linearisierten Konstrukten vollständiger Klone, oder mit partiellen, sog. „head-to-tail“ Dimeren von DNA-A und DNA-B, resultierte in einer Übertragung der jeweiligen DNA-A Genomkomponenten in die Wirtspflanze. In heterologen Genomkombinationen konnten nur die DNA-A Genomkomponenten in inokulierten Pflanzen mit sehr schwachen Symptomen nachgewiesen werden. Nur mit homologen Kombinationen mit ACMV DNA-A und DNA-B Genomkomponenten wurden Infektionen in *N. benthamiana* mit einem vollständigen und infektiösen Virus erreicht. Dies zeigte, dass eine spezifische DNA-B Genomkomponente für EACMV-UgV existieren muss, die jedoch bislang nicht gefunden wurde.

Die Resistenzzüchtung von Cassava gegen die Begomoviren und die Produktion von virusfreiem Pflanzenmaterial ist besonders problematisch, da resistente Zuchtlinien und sauberes bzw. virusfreies Material nur schwer zu selektieren sind. Zuverlässige und sensitive Virusnachweismethoden würden hier eine substantielle Verbesserung der Virus-Indexierungsroutinen darstellen. Serologische Methoden und Nukleinsäuretechniken wurden entwickelt und auf ihre Zuverlässigkeit und Empfindlichkeit geprüft, um Begomoviren in Maniok nachzuweisen und zu differenzieren. Monoklonale Antikörper (MAbs), die in TAS-ELISA Verfahren eingesetzt werden, sind nützlich, um den Virusstatus in Maniok festzustellen. Wenn eine definitive Aufklärung von Mischinfektionen gefordert wird oder Viren in Cassava zweifelsfrei identifiziert werden müssen, kann jedoch nur mit Hilfe der PCR eine klare Differenzierung zwischen den Begomoviren erreicht werden.

Für Routineuntersuchungen von Pflanzenzüchtern und Vermehrungsbetrieben und zum Virusnachweis und Virusidentifizierung in der Pflanzenquarantäne sind nun adäquate Methoden vorhanden, Begomoviren in Maniok zu diagnostizieren.

Schlagworte: Cassava Mosaik Begomoviren, Diagnose, Verbreitung

TABLE OF CONTENTS

| | | |
|-------|--|----|
| 1 | INTRODUCTION | 1 |
| 1.1 | The cassava plant | 1 |
| 1.1.1 | Origin and description | |
| 1.1.2 | Cassava production in Africa | 2 |
| 1.1.3 | Constraints to cassava production in Africa | 3 |
| 1.2 | The cassava mosaic disease in Africa | 4 |
| 1.2.1 | History and economic importance | 4 |
| 1.2.2 | Aetiology | 6 |
| 1.3 | Geminiviruses as causal agents of the cassava mosaic disease | 7 |
| 1.3.1 | General features and taxonomic assignment | 7 |
| 1.3.2 | Begomovirus genome structure | 8 |
| 1.3.3 | Recombination | 10 |
| 1.3.4 | Antigenic variation | 12 |
| 1.3.5 | Virus transmission and spread | 13 |
| 1.4 | Objective and scope of the study | 14 |
| 2. | MATERIALS AND METHODS | 16 |
| 2.1 | Viruses and virus isolates | 16 |
| 2.1.1 | Reference strains and sample collection | 16 |
| 2.1.2 | Survey of cassava mosaic disease in Kenya | 18 |
| 2.1.3 | Maintenance and transmission of viruses and virus isolates | 19 |
| 2.2 | Serological assays | 21 |
| 2.2.1 | Antisera and monoclonal antibodies used for serological analysis | 21 |
| 2.2.2 | Production of monoclonal antibodies | 22 |

II

| | | |
|----------|---|----|
| 2.2.2.1 | Antigen preparation | 22 |
| 2.2.2.2 | Materials, media, animals and cell lines | 22 |
| 2.2.2.3 | Immunization scheme | 24 |
| 2.2.2.4 | Growth of myeloma cell lines | 24 |
| 2.2.2.5 | Production of hybridomas | 25 |
| 2.2.2.6 | Growth of hybridomas | 26 |
| 2.2.2.7 | Detection and selection of antibody-secreting hybridoma cells | 26 |
| 2.2.2.8 | Cell cloning | 27 |
| 2.2.2.9 | Harvesting Mabs | 28 |
| 2.2.2.10 | Cryopreservation of cell cultures | 28 |
| 2.2.2.11 | Naming of Mabs | 29 |
| 2.2.2.12 | Concentration of MAbs from culture supernatants | 29 |
| 2.3 | Enzyme-linked immunosorbent assay (ELISA) | 29 |
| 2.3.1 | Preparation of IgG | 29 |
| 2.3.2 | Labelling of IgG with alkaline phosphatase | 30 |
| 2.3.3 | ELISA formats | 32 |
| 2.3.3.1 | Sample preparation | 32 |
| 2.3.3.2 | Double antibody sandwich ELISA (DAS-ELISA) | 32 |
| 2.3.3.3 | Triple antibody sandwich ELISA (TAS-ELISA) | 33 |
| 2.3.3.4 | Tissue-blot immuno-assay (TBIA) | 34 |
| 2.4 | Protein analysis | 35 |
| 2.4.1 | SDS-polyacrylamide gel electrophoresis (SDS-PAGE) | 35 |
| 2.4.2 | Electro-blot immunoassay (EBIA/ Western-blot) | 38 |
| 2.4.2.1 | Protein transfer to polyvinylidene difluoride (PVDF) membranes - Electroblothing | 39 |
| 2.4.2.2 | Immunological detection of viral coat proteins | 40 |
| 2.5 | Electron Microscopy (EM) | 41 |
| 2.5.1 | Adsorption preparations | 41 |
| 2.5.2 | Immunosorbent electron microscopy (ISEM) | 42 |

| | | |
|---------|--|----|
| 2.6 | Nucleic acid analysis | 42 |
| 2.6.1 | Extraction of total DNA from virus-infected leaves | 42 |
| 2.6.2 | Quantification of DNA | 44 |
| 2.6.2.1 | Spectrophotometric determination | 44 |
| 2.6.2.2 | Agarose gel electrophoresis | 44 |
| 2.6.3 | Preparation of tissue-prints and plant sap dot-blot | 46 |
| 2.6.4 | Preparation of DNA probes | 47 |
| 2.6.5 | DNA hybridization and autoradiography | 48 |
| 2.6.6 | Detection of begomovirus DNA-A genomic sequences by Polymerase chain reaction (PCR) | 49 |
| 2.7 | Nucleic acid manipulations | 51 |
| 2.7.1 | Cloning begomovirus genome fragments and full-length DNA-A and DNA-B genomic components | 51 |
| 2.7.1.1 | Growth media and buffer solutions | 51 |
| 2.7.1.2 | Enzymes, plasmid vectors and preparation kits | 53 |
| 2.7.1.3 | Amplification and cloning of coat protein genes | 53 |
| 2.7.2 | Cloning of coat protein genes in the pBluescript II SK- plasmid vector | 54 |
| 2.7.3 | Cloning of PCR fragments in pGEM-T | 55 |
| 2.7.4 | Preparation of competent cells - DND method | 56 |
| 2.7.5 | Transformation of <i>Escherichia coli</i> | 57 |
| 2.7.6 | Plasmid preparations | 57 |
| 2.7.6.1 | Extraction of plasmid DNA from <i>E. coli</i> | 57 |
| 2.7.6.2 | Analysis of plasmid minipreparations for presence of DNA fragments | 59 |
| 2.8 | Sequencing and sequence analysis | 59 |
| 2.9 | Generation of full-length DNA-A and DNA-B genomic clones | 60 |
| 2.9.1 | Use of degenerate primers to amplify DNA-B fragments | 60 |
| 2.9.2 | Amplification of full-length DNA-A and –B components using abutting primers | 61 |
| 2.9.3 | Cloning of full-length DNA-A genomic components | 62 |

| | | |
|---------|--|----|
| 2.9.4 | Cloning of full-length DNA-B genomic components | 65 |
| 2.9.5 | Inoculation studies to infect <i>Nicotiana benthamiana</i> with cloned full-length virus genomes | 67 |
| 2.10 | Expression of EACMV and UgV coat protein genes | 67 |
| 2.10.1 | Construction of the expression vector pET (cpEACMV and cpUgV) | 68 |
| 2.10.2 | Transformation of Epicurian coli® strain BL21 (DE3) pLysS | 69 |
| 2.10.3 | Expression of fusion proteins | 69 |
| 2.10.4 | Purification of recombinant protein from expressed <i>E. coli</i> BL21 (DE3) pLysS cells | 71 |
| 2.10.5 | Detection of coat protein by electro-blot immunoassay | 72 |
| 2.11 | Characterization of filamentous viruses from cassava | 72 |
| 2.11.1 | Mechanical transmission and host range studies | 72 |
| 2.11.2 | Virus propagation and purification | 73 |
| 3. | RESULTS | 74 |
| 3.1 | Characterization of begomoviruses infecting Cassava in Africa | 74 |
| 3.1.1 | Symptoms of ACMV, EACMV, and UgV in Cassava and in <i>Nicotiana benthamiana</i> | 74 |
| 3.1.2 | Mechanical transmission of begomoviruses infecting cassava to <i>Nicotiana benthamiana</i> | 77 |
| 3.1.3 | Particle morphology | 80 |
| 3.1.4 | Analysis of viral capsid proteins | 81 |
| 3.2 | Serological assays, nucleic acid hybridization and PCR | 82 |
| 3.2.1 | Production and characterization of monoclonal antibodies, Mabs | 82 |
| 3.2.1.1 | Expression of EACMV coat protein in bacteria for antigen preparation | 82 |
| 3.2.1.2 | Titre determination of monoclonal antibodies in hybridoma cell culture supernatants | 83 |
| 3.2.1.3 | Evaluation of monoclonal antibodies for detection and differentiation of begomoviruses | 83 |

| | | |
|---------|--|-----|
| 3.2.1.4 | Determination of antibody classes and subclasses | 85 |
| 3.2.1.5 | Particle decoration and ISEM | 85 |
| 3.2.2 | Detection of begomoviruses by ELISA | 86 |
| 3.2.3 | Detection of begomoviruses by tissue blot immuno-assay, TBIA | 87 |
| 3.2.4 | Detection of begomoviruses in cassava by nucleic acid hybridization | 89 |
| 3.2.5 | Detection and differentiation of cassava begomoviruses by PCR | 90 |
| 3.3 | Survey of CMD in Kenya | 91 |
| 3.3.1 | CMD symptoms in cassava fields | 91 |
| 3.3.2 | Locations and samples collected | 92 |
| 3.3.3 | Cropping systems, disease symptoms, and other pests | 93 |
| 3.3.4 | CMD severity and incidence | 94 |
| 3.3.5 | Sample analysis by TAS-ELISA and PCR for cassava begomoviruses | 95 |
| 3.4 | Distribution of cassava begomoviruses in Africa | 98 |
| 3.4.1 | Analysis of of CMD affected cassava materials from Africa | 98 |
| 3.4.2 | Distribution of ACMV, EACMV, and UgV in Africa | 101 |
| 3.5 | Sequence analysis | 103 |
| 3.5.1 | Amplification and analysis of DNA-A genomic components | 103 |
| 3.5.2 | Comparison of coat protein genes | 104 |
| 3.5.3 | Comparison of DNA-A nucleotide sequences | 111 |
| 3.5.4 | Comparison of DNA-A intergenic regions | 113 |
| 3.5.5 | Comparison of DNA-A ORFs of EACMV-UgV (Ca002) with those of other cassava begomoviruses | 116 |
| 3.5.6 | Analysis of DNA-B genomic components | 117 |
| 3.6 | Infectivity studies of cloned begomovirus genomes | 119 |
| 3.6.1 | Mechanical inoculation of cloned DNA-A and DNA-B genomic components | 119 |
| 3.7 | Characterization of other viruses from Cassava | 122 |
| 3.7.1 | Host range and symptomatology | 122 |
| 3.7.2 | Description of particle morphology | 126 |

VI

| | | |
|-------|---|-----|
| 3.7.3 | Virus propagation and purification trials | 128 |
| 3.7.4 | Determining capsid proteins of putative filamentous viruses of Cassava | 128 |
| 4 | DISCUSSION | 130 |
| 5 | LIST OF REFERENCES | 143 |
| 6 | ANNEX | 160 |
| | List of tables | 160 |
| | List of figures | 161 |
| | List of begomovirus isolates selected for genetic analysis | 163 |
| | Begomovirus sequences used for comparative analysis | 164 |

ACKNOWLEDGEMENTS

CURRICULUM VITAE

List of abbreviations

| | |
|----------------|--|
| A | absorbance |
| A | adenine |
| aa | amino acid(s) |
| AP | alkaline phosphatase |
| APS | ammonium persulphate |
| AS | antiserum |
| bp | base pair(s) |
| BSA | bovine serum albumin |
| <i>Bam</i> H I | restriction enzyme isolated from <i>Bacillus amyloliquefaciens</i> H |
| C | cytosine |
| CMD | cassava mosaic disease |
| CP | coat protein |
| CR | common region |
| DAS | double antibody sandwich |
| DMSO | dimethyl sulfoxide |
| DNA | deoxyribonucleic acid |
| DNase | deoxyribonuclease |
| dNTP | 2',3 '-deoxyribonucleoside 5'-triphosphate |
| DRC | Democratic Republic of the Congo |
| ds | double stranded |
| DTT | dithiothreitol |
| EBIA | electro-blot immunoassay |
| <i>Eco</i> RI | restriction enzyme isolated from <i>Escherichia coli</i> RY13 |
| <i>Eco</i> RV | restriction enzyme isolated from <i>Escherichia coli</i> |
| EDTA | ethylendiamine tetra-acetic acid |
| ELISA | enzyme-linked immunosorbent assay |
| EM | electron microscope |
| EMBL | European Molecular Biology Laboratory |
| <i>et al.</i> | and others |
| Fig. | figure |
| g | gram(s) |

VIII

| | |
|----------------|---|
| G | guanine |
| GAR | goat anti rabbit |
| GenBank | National Center for Biotechnology Information, NCBI Gene bank |
| h | hour(s) |
| <i>HindIII</i> | restriction enzyme isolated from <i>Haemophilus influenzae</i> Rd |
| IC-PCR | immunocapture polymerase chain reaction |
| IgG | immunoglobulin G |
| IgM | immunoglobulin M |
| IL-6 | Interleukin-6 |
| IPTG | isopropyl β -D-thiogalactopyranoside |
| IR | intergenic region |
| IR-A | intergenic region DNA-A |
| ISEM | immunosorbent electron microscopy |
| kDa | kilodalton(s) |
| LB | Luria Bertani-medium |
| LL | local lesion(s) |
| M | molar |
| MAb | monoclonal antibody |
| min | minute(s) |
| M _r | relative molecular mass |
| <i>Nco I</i> | restriction enzyme isolated from <i>Nocardia corallina</i> |
| nt | nucleotides |
| OD | optical density |
| ORF | open reading frame |
| PAGE | polyacrylamide gel electrophoresis |
| PBS | phosphate buffered saline |
| PCR | polymerase chain reaction |
| PEG | polyethyleneglycol |
| PVDF | polyvinylidene difluoride |
| PVP | polyvinylpyrrolidone |
| RAM | rabbit anti mouse |
| REn | replication enhancer protein gene |
| REP | replication initiator protein gene |

| | |
|--------------|---|
| RNA | ribonucleic acid |
| RNase | ribonuclease |
| rpm | revolutions per minute |
| RT-PCR | reverse transcription polymerase chain reaction |
| SDS | sodium dodecylsulphate |
| sec. | second(s) |
| sp. | species (singular) |
| spp. | species (plural) |
| ss | single stranded |
| T | thymine |
| Taq | <i>Thermophilus aquaticus</i> |
| TAS | triple antibody sandwich |
| TBIA | tissue blot immunoassay |
| TEMED | N,N,N',N'-tetramethylethylenediamine |
| TFB | transformation buffer |
| TrAP | transcription activator protein gene |
| Tris | tri(hydroxymethyl)aminomethane |
| U | unit |
| UAc | uranyl acetate |
| UV | ultraviolet |
| vol. | volume |
| v/v | volume per volume |
| w/v | weight per volume |
| <i>Xba</i> I | restriction enzyme isolated from <i>Xanthomonus badrii</i> |
| X-gal | 5-bromo-4-chloro-3-indolyl β -D-thiogalactopyranoside |

Nucleotide symbol combinations (IUPAC code)

Pairs: K = G/T; M = A/C; R = A/G; S = C/G; W = A/T; Y = C/T

Triples: B = C/G/T; D = A/G/T; H = A/C/T; V = A/C/T; N = A/C/G/T

Amino acid codes

| | |
|---------------|---|
| Alanine | A |
| Arginine | R |
| Asparagine | N |
| Aspartic acid | D |
| Asparagine or | B |
| Aspartic acid | B |
| Cystein | C |
| Glutamine | Q |
| Glutamic acid | E |
| Glutamine or | Z |
| Glutamic acid | Z |
| Glycin | G |
| Histidine | H |
| Isoleucine | I |
| Leucine | L |
| Lysine | K |
| Methionine | M |
| Phenylalanine | F |
| Proline | P |
| Serine | S |
| Threonine | T |
| Tryptophan | W |
| Tyrosine | Y |
| Valine | V |

List of virus names and acronyms

| | |
|-----------|---|
| AbMV | <i>Abutilon mosaic virus</i> |
| ACMV | <i>African cassava mosaic virus</i> |
| BGMV | <i>Bean golden mosaic virus</i> |
| BCTV | <i>Beet curlytop virus</i> |
| CALV | <i>Cassava American latent virus</i> |
| CBB | <i>Cassava bacterial blight</i> |
| CBSV | <i>Cassava brown streak virus</i> |
| CCMV | <i>Cassava common mosaic virus</i> |
| CGMV | <i>Cassava green mottle virus</i> |
| CIBV | <i>Cassava Ivorian bacilliform virus</i> |
| CVMV | <i>Cassava vein mosaic virus</i> |
| CsXV | <i>Cassava x virus</i> |
| CLCrV | <i>Cotton leaf crumble virus</i> |
| CLCV-Pk | <i>Cotton leaf curl virus from Pakistan</i> |
| EACMV | <i>East African cassava mosaic virus</i> |
| ICMV | <i>Indian cassava mosaic virus</i> |
| MSV | <i>Maize streak virus</i> |
| SACMV | <i>South African cassava mosaic virus</i> |
| SqLCV | <i>Squash leaf curl virus</i> |
| SgMV | <i>Sida golden mosaic virus</i> |
| TLCV | <i>Tobacco leaf curl virus</i> |
| TGMV | <i>Tomato golden mosaic virus</i> |
| TPCTV | <i>Tomato pseudo-curlytop virus</i> |
| TYLCV | <i>Tomato yellow leaf curl virus</i> |
| TYLCV-Sar | <i>Tomato yellow leaf curl Sardinia virus</i> |
| ToLCV-AU | <i>Tomato leaf curl virus- Australia</i> |
| UgV | <i>Uganda variant East African cassava mosaic virus</i> |
| EACMV-UgV | <i>Uganda variant East African cassava mosaic virus</i> |
| WDV | <i>Wheat dwarf virus</i> |

1 INTRODUCTION

1.1 The cassava plant

1.1.1 Origin and description

Cassava (*Manihot esculenta* Crantz) originated in South America where it was domesticated between 4000-2000 B.C. Portuguese sailors first brought cassava to the Gulf of Guinea in Africa in the 16th century, to the East African coast and the Indian Ocean islands of Madagascar, Reunion and Zanzibar, and probably to India and Sri Lanka in the 18th century. In Africa, cassava was not accepted at first, but in the 19th century it extended rapidly across the continent and it is now grown in 39 countries.

Cassava belongs to the botanical family *Euphorbiaceae* and, like most other members of the family, it contains latex and produces latex. Cassava is the only member of the genus that is cultivated as a food crop.

Numerous cassava cultivars exist in each locality where the crop is grown. They can be distinguished on the basis of morphology (leaf shape and size, plant height, petiole colour etc.), earliness to maturity, yield and cyanogenic glucoside content of the roots. Based on the last characteristic, cassava cultivars have been placed into two groups: the bitter varieties in which the cyanogenic glucoside is high and is distributed throughout the tuber, and the sweet varieties, in which the glucoside content is low and is confined mainly to the peel. The flesh of the sweet varieties is therefore relatively free of glucosides (Purselove, 1968).

Cassava is cultivated throughout the year up to a maximum altitude of 2000 m and prefers a warm moist climate where mean temperatures range from 25 – 29°C. Apart from the first few weeks after planting, cassava tolerates drought but performs best where annual rainfall reaches 1000 – 2000 mm. Continuous light delays tuberization and lowers yields (Mogilaer *et al.*, 1967). Cassava is therefore most productive when day length is up to 12 hours and hence between latitudes of 30° S and 30° N. The best soils for cassava are light, sandy loam with medium fertility and good drainage.

On a world basis average yields are estimated between 5 – 10 tonnes/ha, however, on experimental stations yields of up to 80 tonnes/ha have been recorded. Cassava is ranked high among the top ten most significant food crops produced in developing countries (Scott *et al.*, 2000 a, b) and as a major source of carbohydrate for human consumption throughout the tropics, but particularly in Africa (Fauquet and Fargette, 1990). Cassava is grown and consumed by the world's poorest and most food-insecure households. Besides, it adapts to a wide range of uses: food security crop (consumed in fresh or processed form), cash crop, feed crop, and raw materials for industrial uses such as starch and alcohol production (Wright, 1996; Kisgeci, 1989). Thus cassava constitutes an important source of income in rural and often marginal areas, and for women. The total world production in the year 2000 was 172,737,202 tonnes with 91,849,415 tonnes being produced in Africa alone (FAO, 2000).

1.1.2 Cassava production in Africa

The importance of cassava to African agriculture was described in detail by Johnston (1958) and Jones (1959). A recent study on cassava was done by the Collaborative Study on Cassava in Africa (COSCA) under the umbrella of the IITA and results are reported in 12 COSCA working papers (Carter and Jones, 1989). In Africa, cassava is produced by traditional farmers on a subsistence basis and over 200 million people are employed in the cassava industry. In the year 2000, the area under cassava cultivation in Africa was 10,006,678 ha with Kenya contributing over 100,000 ha. The total cassava production was 91,849,415 and 950,000 metric tonnes for Africa and Kenya, respectively (FAO, 2000). Production and consumption of cassava is expected to rise in the next two decades due to population growth, low and stagnant per capita incomes and rapid urbanisation all of which generate demand for cheap starchy staple to feed the poor rural and urban consumers alike (Scott, *et al.*, 2000 b).

1.1.3 Constraints to cassava production in Africa

Since cassava is not indigenous to Africa, there are a few pest and disease constraints for the crop on the continent. In the early 70s, the following two new pests appeared.

- The cassava green mite, *Mononychellus tanajoa* Bondar (*Acari, Tetranychidae*), first observed in Uganda (Nyiira, 1972).
- The cassava mealybug, *Phenacoccus manihoti* Matile-Ferrero, (*Homoptera, Pseudococcidae*), first observed in what is now known as Democratic Republic of the Congo (Leuschner, 1978).

The two pests were imported inadvertently with planting material from Latin America, and they cause significant damage to cassava. The mealybug has now been brought under economically manageable levels using biological control measures coordinated by the Kenya Agricultural Research Institute (KARI) and the International Institute of Tropical Agriculture (IITA) (Herren and Neuenschwander, 1991) while the cassava green mite is being controlled using a similar approach (Schaab, 1977; Yaninek *et al.*, 1993).

About 30 diseases of cassava have been described worldwide. In Africa, Cassava Bacterial Blight (CBB) caused by *Xanthomonas campestris* pathovar *manihotis* has been reported occurring sporadically in parts of the Kenyan coast and mount Elgon areas. This bacterial disease also has been reported from Brazil, whereas *Ralstonia solanacearum* was only found on cassava in Indonesia.

Fungal diseases include cassava anthracnose caused by *Glomerella cingulata* (*Colletotrichum gloeosporioides f.sp.manihotis*), dry root and stem rot caused by *Diplodia manihotis* (Asia and tropical America), Phomopsis blight caused by *Phomopsis manihotis* (perfect stage *Diaporthe manihotis*) and related species, superelongation disease caused by *Sphaceloma manihoticola* (perfect stage *Elsinoe brasiliensis*).

Several viral diseases have been reported. They include: cassava mosaic disease caused by *African cassava mosaic begomoviruses*; cassava brown streak disease caused by *Cassava brown streak virus* (CBSV) reported along the coast of Kenya (Bock, 1994c); *Tobacco leaf curl virus* (TLCV); *Cassava common mosaic virus*

(CCMV), (South America, Ivory coast); *Cassava green mottle virus* (CGMV), (Solomon islands); *Cassava vein mosaic virus* (CVMV), (Brazil); *Cassava American latent virus* (CALV), (Brazil and Guyana); *Cassava Ivorian bacilliform virus* (CIBV), (Cote d'Ivoire); *Cassava x virus* (CsXV), (Columbia); *Cassava c virus* (an unnamed virus), (Cote d'Ivoire, Malawi and Cameroon) and Frogskin disease (FSD) for which the causal agent is unknown but a virus is suspected (Columbia). Other diseases are: Cassava antholysis (Brazil, the Caribbean, Central America) and Cassava witches' broom (Brazil and Mexico), diseases caused by phytoplasmas

1.2 The Cassava mosaic disease in Africa

1.2.1 History and economic importance

Cassava mosaic disease is predominantly a foliar disease and the symptoms range from chlorotic spots, leaf curling, bright mosaic and stunting of severely affected plants. The severity of symptoms depends on environmental factors (Gibson and Otim-Nape, 1997), type of infection, with mixed infections being more severe than single infections (Harrison *et al.*, 1997; Fondong *et al.*, 2000), virus or virus strain (Gibson *et al.*, 1996) and, the variety of the cassava plant (Gibson and Otim-Nape, 1997).

The disease was first reported from what is now known as Tanzania (Warburg, 1894). Thereafter, research efforts were fragmented and not sustained until the late 1980s. During this time, there were two research programmes, the first based in Amani, Tanzania, ran from the 1930s through to the 1950s, the second was within the framework of plant virology research in Kenya and ran from the 1970s through to the mid 80s. The work at Amani provided the first epidemiological information on CMD (Storey, 1938), described virus strains (Storey, 1936) and mechanisms of transmission (Storey and Nichols, 1938). The work on virus resistant germplasm selection was also initiated (Nichols, 1947; Jennings, 1957) and later formed the basis for the major germplasm development programme of IITA (Hahn *et al.*, 1980).

The Kenyan virology research project provided the definitive proof for the aetiology of the cassava mosaic disease (Bock and Woods, 1983), developed an understanding of the factors determining its epidemiology (Bock, 1987; 1994a),

quantified yield losses (Seif, 1982), described the population dynamics of the whitefly vector (Robertson, 1987) and outlined control measures (Bock, 1994b). None of these two programmes however, provided quantitative information on the prevalence of CMD in Kenya or Tanzania.

The disease incidence is often high, ranging from 25% in some areas and may exceed 80% in others (Bock and Guthrie, 1982; Otim-Nape, 1993; Otim-Nape *et al.*, 1998; Legg and Raya, 1998). Currently a particularly severe epidemic of the disease is sweeping across Eastern and Central Africa (Gibson *et al.*, 1996; Legg and Okoa-Okuja, 1999). The worst effects of which were reported in North Eastern Uganda and Western Kenya (Otim-Nape *et al.*, 1997) where cassava varieties being grown were highly susceptible to the disease. Losses were therefore great, and farmers responded by completely abandoning cultivation of the crop. The localised food shortages resulting from this epidemic led to a number of famine related deaths (Otim-Nape, *et al.*, 1996).

The first attempt to estimate the overall losses caused by CMD in Africa was made by Watts Padwick (1956) who put losses in the then British colonies to 15%. Fargette *et al.* (1988) using data from Ivory Coast reported a 35% crop loss in one of the main varieties being grown when plants were raised from infected cuttings. Those assessments were made on the assumption that almost a total infection with ACMV existed in all cassava-growing areas of Africa. Thresh *et al.* (1994) revised these estimates of the overall losses caused by CMD and provided a more realistic assumption with 70 – 80% of all plants being infected with CMD and sustaining an average yield loss between 40 – 50%. Recent surveys in Uganda and Nigeria (Yanineck *et al.*, 1993) suggest a CMD incidence in the range of 50 – 60% for Africa, which is considerably lower than the previous assumptions. This, combined with a yield loss of 30 – 40% puts overall losses at 15 – 24%, equivalent to 1,500 – 2,400 million tonnes. Based on an annual cassava production figure of 92 million tonnes (FAO, 2000) and given a conservative value of US \$ 100.00 per tonne, such losses are equivalent to US \$1.5 – 2.4 billion.

In Western Kenya, cassava production and financial losses associated with the disease is well over 140,000 tonnes which is half the total production figure of 430,000 tonnes (FAO, 1997), equivalent to US \$ 14 million. This is based on the

assumption that overall CMD incidence is over 70% (Legg *et al.*, 1999) and yield losses attributed to severe CMD is 40%. Comparable calculations for Uganda (Otim-Nape *et al.*, 1997) put annual losses there to be US \$ 60 million.

1.2.2 Aetiology

Pioneering work on CMD (Bock *et al.*, 1978; 1981) revealed that the disease is caused by a geminivirus and that the virus is transmitted by whiteflies. Subsequent work (Bock and Woods, 1983; Hong *et al.*, 1993; Zhou, *et al.*, 1997; Rey and Thompson, 1998) triggered by outbreaks of a severe form of the disease, associated it with at least four distinct whitefly transmitted geminiviruses (WTGs). Three species, the *African cassava mosaic virus* (ACMV), the *East African cassava mosaic virus* (EACMV) and the *South African cassava mosaic virus* (SACMV) occur in Africa. SACMV is closely related to EACMV but probably resembles more a virus from tomato since a recombination likely to be from a tomato virus was detected in its AC1, Rep-gene (Berrie *et al.*, 2001). Improved diagnostic techniques have resulted in identification of other begomoviruses. In Uganda and the neighbouring countries, a new virus variant has been detected and identified. This virus resembles EACMV because most of its genome is derived from the virus except the core region of the coat protein gene, which is identical to that of ACMV. The virus has been referred to as a distinctive strain of EACMV (EACMV-UG) (Deng *et al.*, 1997) or as the *Uganda variant cassava mosaic virus* (UgV) (Zhou *et al.*, 1997).

Until recently (Harrison, *et al.*, 1991; 1995), it was thought that EACMV and ACMV had distinct but largely non-overlapping geographical distributions with ACMV occurring in West, Central and Central Southern Africa, while EACMV was largely restricted to the East African coast, Madagascar, Malawi, Mozambique and Zimbabwe. Latest studies (Gibson, 1996; Ogbé *et al.*, 1996; 1997; Legg *et al.*, 1999; Fondong *et al.*, 2000) showed that EACMV occurs over a much wider area including Western Kenya, Western Tanzania, Zambia, Nigeria, Togo, Guinea, Ivory Coast and Cameroon. Epidemiological data for EACMV occurring in West Africa from cassava growing regions where the virus was found, is however lacking.

The highly aggressive and rapidly spreading UgV has been detected in samples from Uganda, Tanzania, Rwanda and Southern Sudan (Harrison *et al.*, 1997; Legg

and Okoa-Okuja, 1999a). It is worth noting that until now, a begomovirus causing indistinguishable disease on cassava in India, the *Indian cassava mosaic virus* (ICMV) has not been reported from Africa.

1.3 Geminiviruses as causal agents of the cassava mosaic disease

1.3.1 General features and taxonomic assignment

Geminiviruses are a large diverse family of plant viruses that infect a broad variety of plants and cause significant crop losses worldwide. They are characterized by their bisegmented (geminate) shape and size (30 x 20nm) of their particles, a capsid protein of about 30 kDa and by their propensity to infect phloem cells. Each geminate particle encapsidates a small (2.5 – 3.0 kb) circular single stranded (ss) DNA genome that replicates in the nuclei of host cells via a double stranded (ds) DNA intermediate through a rolling circle mechanism (Saunders *et al.*, 1991). They are classified within the family *Geminiviridae*. The *Geminiviridae* consist of four genera that differ with respect to host range, genome organisation and vector species (Rybicki, 1994; Briddon *et al.*, 1995; Padidam *et al.*, 1995a; Fauquet *et al.*, 2000).

Mastreviruses (formally subgroup I) such as *Maize streak virus* (MSV) and *Wheat dwarf virus* (WDV) have monopartite genomes, are transmitted by leafhoppers and, with a few exceptions, infect monocots.

Curtoviruses (formally subgroup II) such as *Beet curly top virus* (BCTV) and *Horseradish curly top virus* (HrCTV) occupy an intermediate position between Mastreviruses and Begomoviruses, in that they have monopartite genomes, are transmitted by leafhoppers but infect dicots.

Topocuviruses (formally classified under curtoviruses) such as *Tomato pseudo-curly top virus* (TPSTV) have a monopartite genome, infect dicots and are transmitted by a species of a treehopper, *Micrutalis malleifera*, Fowler.

Begomoviruses (formally subgroup III) such as *Bean golden mosaic virus* (BGMV) and *African cassava mosaic virus* (ACMV) are transmitted by whiteflies (*Bemisia tabaci*) all infect dicots and, with a few exceptions, have bipartite genomes.

1.3.2 Begomovirus genome structure

The circular single stranded DNA genomes of begomoviruses are mostly bipartite and both components (DNA-A and DNA-B) are approximately 2500 to 2800 nt (Fig. 1) and have protein coding sequences (ORFs) in the virus and complementary strands respectively. DNA-A contains two genes (AV1 and AV2) in the virus strand and four genes (AC1, AC2, AC3 and AC4) in the complementary strand. DNA-B contains one gene (BV1) in the virus strand and one gene (BC1) in the complementary strand.

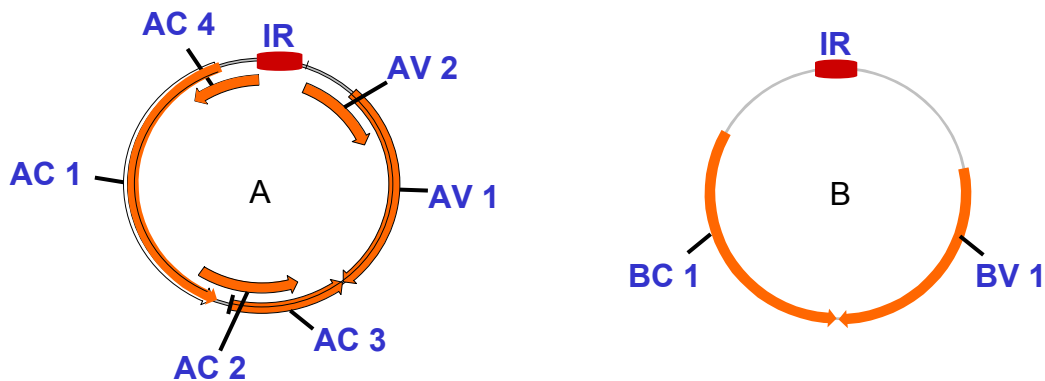

Figure 1. Genome organisation of a typical begomovirus. Arrows show arrangements of ORFs in the genomic DNA-A (left) and DNA-B (right) of ACMV. ORFs indicated occur in all cassava begomoviruses and the IRs contain shared sequences in both components.

Between the initiation codons of AV2 and AC1 in DNA-A lies the intergenic region (IR) and in DNA-B there is an equivalent IR between the initiation codons of BV1 and BC1. Because these two IRs are the only regions in both components with high sequence similarity (90-100%), they are referred to as the common region (CR) and each is approximately 200 nt and contains several regulatory elements including two TATA motifs, one near 3' end and the other at the 5' half which are probably involved in initiation of transcription of AV1 and/ or AV2 and AC1 and/ or AC4 respectively. The 5' half also contains sequence elements of 6 – 12 nt that are repeated 2 – 5 times sometimes imperfectly sometimes in inverted orientation. These `iterons` are the binding sites for the replicase, Rep, and have a role in the initiation of DNA replication (Argüello-Astorga *et al.*, 1994; Chatterji *et al.* 1999;

Eagle *et al.*, 1994; Fontes *et al.*, 1994; Laufs *et al.*, 1995; Zhan *et al.*, 1991). The conserved nonanucleotide TAATATTAC invariably present in the loop of the hairpin, has the origin of replication at A of the genomic DNA (Laufs *et al.*, 1995; Stanley, 1995).

The virus coat protein (CP) gene (AV1) plays among others a crucial role in vector transmissibility. This role is demonstrated in the following experiments: Begomoviruses are all transmitted by *Bemisia tabaci* and have antigenically related particles whereas many leafhopper transmitted geminiviruses are antigenically unrelated and have different vector species (Roberts *et al.*, 1984). Transferring a CP gene of the leafhopper BCTV into a genome of ACMV conferred on the chimeric virus leafhopper transmissibility (Briddon *et al.*, 1990). Substituting the CP gene of the *B. tabaci* transmitted *Sida golden mosaic virus* (SGMV) for that of the vector non-transmissible begomovirus, *Abutilon mosaic virus* (AbMV) made the latter transmissible by *B. tabaci* (Höfer *et al.*, 1997). A single amino acid substitution in the CP of *Tomato yellow leaf curl virus* (TYLCV) abolished its whitefly transmissibility although its ability to replicate and form geminate particles was not affected (Noris *et al.*, 1998).

AC1 codes for the replicase protein (Rep) that is essential for virus DNA replication (Lauf *et al.*, 1995). The protein product of AC2 is a transcriptional activator for the virus sense genes in both DNA-A and DNA-B (Sunter and Bisaro, 1991). The AC3 product, which is not essential for infectivity, increases virus replication (Sunter *et al.*, 1990).

The virus (V) and complementary (C) strands of DNA-B contain one gene each, BV1 and BC1 respectively. The protein product of BV1 binds and transports ssDNA across the nuclear envelope (Pascal *et al.*, 1994; Sanderfoot *et al.*, 1996a) while that of BC1 plays a role in cell-to-cell movement (Noueiry *et al.*, 1994; Ward *et al.*, 1997). Both gene products are therefore responsible for virus movement in the plant and act cooperatively (Sanderfoot and Lazarowitz, 1996b). The AC4 ORF contained within but not part of AC1 ORF occurs in many begomoviruses. Mutations that destroyed the AC4 ORF without changing the amino acid sequence encoded by AC1 had no effect on the infectivity of, or symptom production by TGMV or ACMV (Elmer *et al.*, 1988; Etesami *et al.*, 1991), but in TYLCV-Sar from

Sardinia and *Tomato leaf curl virus* (ToLCV-AU) from Australia, such mutations led to attenuated symptom development and / or diminished virus movement (Jupin *et al.*, 1994; Rigden *et al.*, 1994). Thus AC4 seems to be functional in begomoviruses that lack DNA-B. AV2 overlapping AV1 has been found in many begomoviruses from the old world but not in those from the new world. Mutations that destroyed AV2 coding sequence and AV1 coat protein gene had no effect on replication but blocked infectivity, most likely by inhibiting movement (Rigden *et al.*, 1993; Padidam *et al.*, 1996). Interestingly, TYLCV V1 and V2 mutants accumulated lower levels of ssDNA (Wartig *et al.*, 1997), suggesting that these proteins sequester viral DNA like AV1 and BV1.

1.3.3 Recombination

Recombination is a physical process culminating in exchange of segments of polynucleotides between two DNA molecules and can result in the progeny of a genetic cross possessing combinations of alleles not displayed by either parent.

Pseudo-recombination. The IR regions of DNA-A and DNA-B are specific for a particular begomovirus and are highly homologous. Pseudo-recombination can be achieved by re-assorting the genomic DNA-A and DNA-B of isolates of the same begomovirus (Stanley *et al.*, 1985) but not of those of distinct begomovirus species (Lazarowitz *et al.*, 1992; Frischmuth *et al.*, 1997) apparently because the heterologous B components are not replicated since their IRs are not homologous enough to allow the binding of the replicase, and not necessarily because their gene products are inactive. It has been shown (Frischmuth *et al.*, 1993) that some DNA-B gene products can mediate movement within the plant of a heterologous DNA-A. Pseudo-recombination may also occur where the parental viruses differ in properties to the extent that taxonomic splitters would regard them as distinct but closely related viruses, whereas lumpers would call them distantly related strains of the same virus (Gilbertson *et al.*, 1993).

Genetic recombination is the rearrangement of the genetic material of a cell or a virus. Evidence that genetic recombination was involved in an evolution of a begomovirus genome comes from identification of chimeric sequences (continuous regions of the nucleotide sequence that are of apparently different origins).

Begomovirus recombination has been observed under a range of experimental conditions (Brough *et al.*, 1988; Etessami *et al.*, 1989; Frischmuth and Stanley, 1998), however, the earliest persuasive evidence of naturally occurring recombination is probably provided by comparing the nucleotide sequences of DNA of mild and severe Israeli strains of TYLCV (Antignus and Cohen, 1994). The other example is provided by the highly virulent begomovirus found in cassava in Uganda named the Uganda variant (UgV). The nucleotide sequence of its DNA-A is essentially identical to that of EACMV except that the central 60% of the CP is virtually the same as that of ACMV and only 75% identical to the equivalent EACMV sequence (Zhou *et al.*, 1997). Serologically UgV is indistinguishable from ACMV, and quite different from EACMV. UgV is therefore a recombinant between EACMV and ACMV that possesses a CP with ACMV like properties. UgV infected plants show severe symptoms, however, some UgV infected plants express only moderate or mild symptoms suggesting that UgV strains differ in virulence and/ or, that cassava genotypes differ in reaction to the virus (Harrison *et al.*, 1997).

Other probable recombinants have now been found among EACMV-like virus isolates from Malawi and Cameroon that incorporate heterologous begomovirus sequences consisting of either the AV2 and CP genes together with the 3' half of the IR (Zhou *et al.*, 1998) or AC2 and AC3 genes (Padidam *et al.*, 1999) in both examples, the second parent is not known.

More recent examples of variation interpreted as recombination in begomoviruses infecting cassava have been reported in a virus resembling EACMV from Cameroon (Fondong *et al.*, 2000). Evidence of recombination was found in AC2-AC3 region and also in BC1 of the DNA-B. In South Africa, Berrie *et al.*, (2001), identified a recombination event in the SACMV spanning the entire AC4 ORF. Both cases incorporated heterologous begomovirus sequences from unknown donor parents.

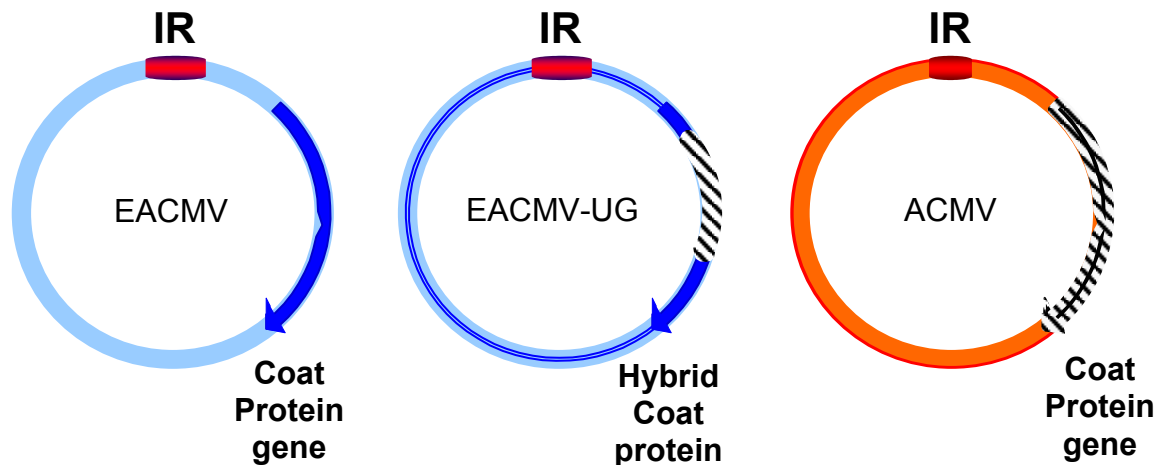

Figure 2. DNA-A components of EACMV (left), ACMV (right) and UgV (center). The core region of ACMV CP is inserted into what is an otherwise an EACMV background forming a hybrid coat protein. Each part of the UgV DNA-A is almost identical to the corresponding part of the DNA-A of one progenitor and differs considerably from that of the other. Despite the hybrid nature of its CP, UgV isolates are serologically indistinguishable from those of ACMV.

1.3.4 Antigenic variation

The extent of serological relationships among different viral species was first observed in work on ACMV, BGMV, *Tomato golden mosaic virus* (TGMV) and *Squash leaf curl virus* (SqLCV), in which the relationship of polyclonal antibodies were tested by immunodiffusion, ELISA and immunosorbent electron microscopy (Cohen *et al.*, 1983; Sequeira and Harrison, 1982; Stein *et al.*, 1983). Other workers (Swanson, 1992; Swanson and Harrison, 1993; Thomas *et al.*, 1986) have explored the nature of these relationships in detail by tests with monoclonal antibodies (MAbs) most of which were specific for discontinuous epitopes (Swanson, 1992). Further works (Harrison *et al.*, 1997; Harrison and Robinson, 1988; Natesh *et al.*, 1996; Swanson *et al.*, 1992) have established that begomoviruses from different hosts in the same geographical region tend to be antigenically more closely related to one another than to viruses causing indistinguishable diseases in other regions. For instance the epitope profile of *Indian cassava mosaic virus* (ICMV) is more similar to that of *Cotton leaf curl virus* from Pakistan (CLCV-Pk) than to ACMV. In turn the epitope profile of CLCV-Pk differs greatly from that of *Cotton leaf crumble*

virus (CLCrV) from the United States, which is more closely related to TGMV from Brazil and BGMV from Puerto Rico.

1.3.5 Virus transmission and spread

Bock and Guthrie (1978) suggested that humans are the principle vectors of ACMV in Kenya because of the widespread and inadvertent use of infected cuttings as planting material. Although the hypothesis does not hold for very susceptible varieties (Bock, 1994b), the most important control measure of CMD is to plant virus-free stem cuttings because cassava begomoviruses are cutting perpetuated and are neither sap transmitted nor are they transmitted through true seed. They can be mechanically transmitted from cassava to several *Solanaceous* plants including species of *Datura* and *Nicotiana* (Bock *et al.*, 1978) but successful transmission back to cassava is difficult and is only feasible with very susceptible cassava cultivars (Bock and Woods, 1983).

The natural vector of cassava begomoviruses, which is responsible for their spread, is the whitefly (*Bemisia tabaci* Gennadius) (Kufferath and Chesquière, 1932; Storey and Nichols, 1938). *B. tabaci* belongs to the order *Homoptera*, family *Aleyrodidae* and sub-family *Aleyrodinae* (Mound and Halsey, 1978; Martin, 1987). Distinguishing *B. tabaci* is complicated by the fact that various factors have been shown to influence nymphal morphology (Mound, 1963; Bethke *et al.*, 1991), which is used when identifying other whitefly species. *B. tabaci* has 4 nymphal instars, the last of which is mobile. The life span of *B. tabaci* depends on temperature but on average is 21 days. The adult is 2 mm long and difficult to identify. The adult whitefly must feed for about 3.5 hours to acquire the virus and needs a latent period of at least 8 hours, and about 10 minutes of inoculation feeding to transmit the virus. The whitefly then remains viruliferous for more than a week and does not lose the virus during molting (Dubern, 1979). No transovarial transmission has been reported. The percentage of individual whiteflies that becomes viruliferous when given access to infected cassava ranges from 0.15% to 1.7% (Dubern, 1979).

The path taken by the virus after being ingested by the insect vector has been explored by Hunter *et al.*, (1998) using a novel technique incorporating immunofluorescence labelling in freshly dissected whiteflies followed by indirect-

fluorescent-microscopy. More recently, Rossel *et al.*, (1999) conducted a more detailed study using Polymerase Chain Reaction (PCR) to track SqLCV in whole whitefly body extracts including saliva, haemolymph and honeydew. The two authors seem to agree with the theory that the virus is ingested along with plant fluids into the oesophagus and foregut. As food enters the filter chamber excess water is shunted to the ileum of the hindgut (Lindsay and Mashall, 1981), thus nutrients and virus become concentrated in the filter chamber. The virus may adsorb to specific sites on the alimentary membranes here or at sites along the anterior region of the midgut but the exact mode of virus entry into the cells is unknown. The virus then moves out of these cells into the haemolymph (Rossel *et al.*, 1997) eventually invading the salivary glands (Briddon *et al.*, 1990). The form (uncoated viral DNA-protein complex or as complete virion) in which the virus moves through the whitefly system is unknown. However, it is likely that once the virus reaches the salivary gland, it passes through the salivary gland membranes via small ductules to the salivary ducts, where it is passed out of the insect with saliva (Esler and Coley-Smith, 1984) into the plant cells where the insect is feeding. Vector distribution, virus concentration and susceptibility to virus inoculations are all related to leaf age. Up to 95% of whiteflies found on cassava are concentrated on the abaxial surface of the five youngest leaves per shoot. Whiteflies are not distributed evenly within cassava fields. Their numbers are highest on the upwind borders and lowest within fields irrespective of field size or whitefly population (Fauquet and Fargette, 1990).

1.4 Objective and scope of the study

The outbreak of an extremely severe epidemic of CMD in Uganda that is advancing in all directions at a rate of 20-25 km/year (Thresh *et al.*, 1997) prompted this study. This aggressive form of the disease has devastated cassava fields and caused food shortages and famine related deaths in the districts where the crop was the major staple (Otim-Nape *et al.*, 1996). A correlation exists between the presence of the new virus recombinant between ACMV and EACMV, UgV, and the epidemic (Deng *et al.*, 1997; Zhou *et al.*, 1997).

This study intended to gain a better understanding of the dynamics of this epidemic and to characterize the viruses involved. A first goal was to conduct an extensive diagnostic survey, to determine the distribution of begomoviruses in cassava growing areas of Kenya and to collect diseased cassava samples showing various types of CMD symptoms. The samples collected were to be analysed to gain an insight into the composition of the diseases and to attribute a specific virus type to a respective disease phenotype. In addition, virus infected cassava leaves and stem cuttings sent by collaborators from a number of countries in Africa were included in the analysis.

With the information on the different viruses gathered, diagnostic methods will be developed, which should help in detecting viruses in infected plant material and, to differentiate between begomoviruses causing CMD in Africa. To achieve this, several approaches were followed, including antibody production for serological detection and differentiation and development of differential PCR tests.

The definition of cassava begomovirus types in cassava will be reached by sequence analysis of DNA-A and DNA-B genomic components of specific viruses. This will provide additional information on molecular variation of viruses contributing to CMD in Africa.

In order to assign disease phenotype to a specific virus type, full-length viral genomes should be constructed to study infectivity of the virus clones. This study of disease phenotypes induced by different homologous and heterologous combinations of virus DNA-A and DNA-B genomic components should provide information on the relationships of the viruses.

The results of the various experimental approaches are reported in this thesis.

2 MATERIALS AND METHODS

2.1 Viruses and virus isolates

2.1.1 Reference strains and sample collection

All virus isolates used in this study were provided by collaborators and colleagues working in various cassava growing regions of Africa or collected during an intensive survey in Kenya conducted in May/July 1999 (Table 1).

The following characterized isolates of cassava begomovirus species and variants provided by Dr. S. Winter of the German Collection of Microorganisms and Cell Cultures (DSMZ), Braunschweig, Germany, were used as reference viruses.

ACMV: African cassava mosaic virus

PV-0095 (ACMV-KE) from Western Kenya,

PV-0421 (ACMV-NG) from Nigeria

EACMV: East African cassava mosaic virus

PV-0423 from Coastal Kenya

UgV: Uganda variant cassava mosaic virus

PV-0422 from Western Kenya

ICMV: Indian cassava mosaic virus

PV-0424 from Kerala, India

Table 1. Countries and cities/locations from which CMD infected cassava samples were obtained

| Country | City/location | Number of samples |
|----------------------------------|------------------------|-------------------|
| Democratic Republic of the Congo | Bas Msokomgulu / Mboka | 4 |
| | Kinshasa | 5 |
| | Kisangani | 17 |
| Ghana | Kumasi | 4 |
| Guinea | Conakry | 8 |
| India | Trivanthuparan | 6 |
| Kenya | Bungoma | 2 |
| | Busia | 6 |
| | Kakamega | 4 |
| | Kilifi | 10 |
| | Kwale | 12 |
| | Luanda | 3 |
| | Siaya | 6 |
| | Suba | 10 |
| | Teso | 6 |
| | Vihiga | 5 |
| Madagascar | Antananarivo | 6 |
| Nigeria | Ibadan | 3 |
| | Isumi K. | 5 |
| Togo | Boke | 11 |
| | Foulaya | 7 |
| | Linsan | 4 |
| | Sinta | 5 |
| Uganda | Busiu | 1 |
| | Kamuli | 2 |
| | Ngiya | 1 |
| | Nyenga | 4 |
| Zambia | Chanda | 3 |
| | Kalipopo | 2 |
| | Ndasemana | 3 |

2.1.2 Survey of cassava mosaic disease in Kenya

During the period May-July 1999, a diagnostic survey for cassava mosaic virus disease (CMD) was conducted in major cassava growing regions of Kenya. The areas surveyed were the districts of Bungoma, Busia, Kakamega, Teso and Vihiga in the Western Province; Suba and Siaya in the Nyanza Province, and Kilifi and Kwale in the Coastal Province (Fig. 3). The study was timed for this season, to take advantage of the vigorous vegetative growth of cassava after the long March - June rains.

The survey was conducted by walking through cassava fields and visually inspecting cassava plants for presence of typical virus disease symptoms as described in section 3.1.1. A questionnaire was used to interview farmers pertaining planting material, varieties grown, cultural practices and presence of other diseases and pests including whiteflies.



Figure 3. Map of Kenya showing locations from which cassava samples with CMD symptoms were collected.

Where cassava plants had just sprouted, the lowermost first formed leaves were examined for CMD symptoms. If symptoms were present, the infection source was considered as originating from infected cuttings. If the oldest leaves of a fully grown cassava plant were symptom free and only the young freshly formed leaves showing symptoms, the infection was considered as derived from inoculation of virus(es) by whitefly transmission.

Disease incidence was calculated according to James (1974) as the percentage of plants showing CMD symptoms to the total number of plants observed in a field. CMD severity on randomly selected plants was determined by scoring level of infection using a 1 – 5 point scale of symptom expression with 1 = no CMD symptom; 2 = presence of mild chlorotic patterns on leaves (often the upper leaves); 3 = an overall moderate mosaic pattern present in all leaves; 4 = severe mosaic and distortion of all leaves with a general reduction of leaf size and; 5 = complete (severe) chlorosis and leaf distortion, plants are severely stunted with very short internodes.

To determine the types of viruses present in cassava, young cassava leaves showing virus-like symptoms were collected in plastic bags and kept cool until further testing by ELISA. Hardwood cuttings from plants with severe CMD symptoms were collected, brought to Germany, rooted and maintained in the greenhouse for further analysis.

2.1.3 Maintenance and transmission of viruses and virus isolates

For maintenance and propagation of viruses and virus isolates, virus-infected cassava (*Manihot esculenta* Crantz) cuttings obtained from different parts of Africa were planted in plastic pots containing sterilized Floradur®:sand mixture (3:1, v/v) and kept in an insect-free glasshouse at 23 – 27°C with a 16 h light period.

Plants were constantly examined for pests particularly mites and insects were sprayed when necessary with Pirimicarb (Pirimor, ICI) or pyrethrin (Spruzit, Neudorff).

All viruses were maintained in cassava varieties in which they were initially collected. Transmission of the viruses to other cassava varieties and breeding lines,

and to *Nicotiana benthamiana* plants was carried out by one of the following three methods:

Sap inoculation: Leaf samples from virus-infected cassava were ground (1:10, w/v) in standard inoculation buffer [0.05 M K/Na phosphate buffer, pH 7.5, containing 2% (w/v) polyvinylpyrrolidone (PVP), 0.2% (w/v) Na₂SO₃]. Leaf homogenates were rubbed on 2-3 carborundum-dusted leaves of *Nicotiana benthamiana* plants at 3-5 leaf stage and the inoculated plants were kept in the glasshouse for 2-8 weeks for symptom observation and further testing.

Grafting: For transmission of viruses to cassava, scions from virus-infected cassava plants were grafted onto the rootstocks of either healthy plants or, to plants that were already virus infected in order to induce mixed infections (of different virus species and variants) and to study their effects on severity of CMD symptoms.

Biolistic inoculation: This method involves the use of a hand-held gun to bombard (deliver) DNA, RNA or purified virus into plant cells. The method is particularly beneficial for plants that are poor hosts of *Agrobacterium*, a natural vector used in gene transfer to plants (Weising *et al.*, 1988). Other advantages offered by the method include the flexibility to use different plasmid constructs, elimination of false positives due to *Agrobacterium* persistence and simplified transformation protocols (Gray and Finer, 1993). In this study, a simple particle bombardment device in which DNA-coated tungsten particles are directly accelerated into plant cells by pressurized air was used. The study was conducted essentially as described by Varrelmann (1999).

For sample preparation, total DNA of virus infected plants was extracted from young symptomatic cassava leaves as described in section 2.6.1. Microcarriers preparation: 100 mg Tungsten (Tungsten M-17 microcarriers ~ 1.1 µm; BioRad#165-2267) were weighed in a 1.5 ml reaction vial, suspended in 1 ml absolute ethanol, vortexed and allowed to soak for 10 min with occasional vortexing. The slurry was then centrifuged for 5 min at 10,000 x g, and washed 3 times each with 1 ml H₂O followed by centrifugation. The final pellet was resuspended in 1 ml H₂O and kept at 4°C until use.

Total plant DNA was adsorbed to the Tungsten suspension using $\text{Ca}(\text{NO}_3)_2$. For each treatment (shot), the following reaction mix was prepared in a 1.5 ml microfuge tube:

- 3 μl DNA (containing approx. 500 ng DNA)
- 3 μl of the Tungsten suspension (vortexed before use)
- 3 μl 1.25 M $\text{Ca}(\text{NO}_3)_2$ pH 8.0

The reaction mix was incubated at room temperature for 5-10 min. For each treatment 6 μl of the supernatant was carefully discarded by aspiration and the reaction mix was then placed on ice until use. For shooting, the slurry was resuspended by vortexing and an aliquot of 3 μl (for each shot) was immediately loaded onto the filter carrier and *N. benthamiana* plants at the 3-5 leaf stage as well as young cassava plants were shot once at a pressure of 4 bars and a vacuum of 800 mbar. The inoculated plants were kept in an insect-free glasshouse for 2-8 weeks and examined daily for symptoms of viral infection.

2.2 Serological assays

2.2.1 Antisera and monoclonal antibodies used for serological analysis

For serological detection and differentiation of cassava mosaic begomoviruses, a polyclonal antiserum for virus trapping (coating) and 11 monoclonal antibodies (MAbs) were used (Table 2). Since the coat proteins of begomoviruses from different hosts within the same geographical region are highly similar (Harrison *et al.*, 1997; Harrison and Robinson 1988; Natesh *et al.*, 1996; Swanson *et al.*, 1992), MAbs raised against *Tomato yellow leaf curl virus* (TYLCV) were screened for detection of the cassava begomoviruses ACMV, EACMV, and their strains and variants.

Table 2. Antibodies used for serological analysis of cassava samples

| Antisera (AS)/MAb | Produced against | Source |
|-------------------|------------------|--|
| AS 0421 | ACMV-NG | DSMZ, Braunschweig |
| MAb SCR 23 | ACMV-NG | Scottish Crop Research Institute (SCR), Dundee, UK |
| MAb SCR 33 | ACMV-NG | “ |
| MAb 4F10 | TYLCV | Dr. Vetten, BBA, Braunschweig |
| MAb 4F11 | ” | “ |
| MAb 1C1 | ” | “ |
| MAb 1H2 | ” | “ |
| MAb 2F1 | “ | “ |
| MAb 6A6 | ” | “ |
| MAb 5D8 | ” | “ |
| MAb 5B5 | ” | “ |
| MAb 4G7 | ” | “ |

2.2.2 Production of monoclonal antibodies

2.2.2.1 Antigen preparation

For further detection of viruses and especially to discriminate between ACMV and UgV, attempts were made to purify begomoviruses from virus-infected *N.benthamiana* plants using the protocol of Sequeira and Harrison (1982). However, virus purity and concentration was not satisfactory and hence no further attempts were made to purify virions.

However, recombinant coat proteins of EACMV and UgV, expressed in and purified from *Escherichia coli* cells (section 2.10) were used as antigens to produce monoclonal antibodies.

2.2.2.2 Materials, media, animals and cell lines

All manipulations were carried out under sterile conditions. Media were prepared using distilled water and sterilized through 0.2 µm pore size filters or, bought sterile. Cell cultures were incubated at 37°C, 8% CO₂ and 95% relative humidity.

Mice: Balb/c strain

Myeloma lines: FOX- NY (derived from NS-1) by Taggart and Samloff (1983), and kindly provided by Dr. Vetten, BBA, Braunschweig, Germany.

DME-Medium: Dulbecco's modified eagles medium (per liter)

13.4 g DME powder (Gibco cat. No. 52100 - 047)

3.7 g Sodium bicarbonate (Gibco cat. No. 066 – 01810)

0.29 g or 2 mM L-Glutamine (Sigma, G-3126)

0.11 g or 1 mM Na-pyruvate (sigma, P-2256)

0.05 g Gentamycin-sulphate (Sigma, G-3632)

5 µl Mercaptoethanol

Adjusted to pH 6.9 with 1M HCl and stored at 4°C.

FBS: Fetal Bovine Serum (CELLect® Silver, Sterile Flow Laboratories, USA).

HAT- additives:

For each 100 ml (100x conc.):

136.1 mg Hypoxanthine (Sigma, H9377) dissolve for 1 h at 50°C.

1.76 mg Aminopterin (Sigma, A1784) dissolve in 90 ml H₂O + 0.5 ml NaOH
neutralize with 0.5 ml HCl add up to 100 ml.

37.8 mg Thymidine (Sigma, T3763)

HAT- Medium:

1 ml Hypoxanthine (100x)

1 ml Aminopterin (100x)

1 ml Thymidine (100x)

20 ml FBS

77 ml DME-Medium

PEG: Polyethyleneglycol (MW 4000, Serva)

IL-6: Interleukin-6 (Human recombinant, Sterile, 200,000U/ml, Cell Biology Boehringer).

DMSO: Dimethylsulfoxide

2.2.2.3 Immunization scheme

The success of any monoclonal antibody production project depends on the immune state of the animal from which the spleen is taken. The induction of antigen-specific B lymphocytes, the fusion of these cells with myeloma cells and the culturing of the resultant hybridoma cells are very important for the efficient production of high antigen specific clones (hybridomas). A good immune response can be elicited through good doses of antigen injections in a given time period.

For production of MAbs, recombinant viral coat protein expressed in bacteria (section 2.10.3) was used. For immunization, the coat protein polypeptide was excised from SDS-PAGE gel, emulsified in 300 μ l 0.5x PBS and injected intraperitoneally into mice. Three (4-month old) mice were immunized receiving two injections each at 2 week intervals. Three days before splenectomy and cell fusion, a booster injection was administered for proliferation of B lymphocytes.

2.2.2.4 Growth of myeloma cell lines

One week before fusion, myeloma cells (FOX-NY) kept in liquid nitrogen were revived from a stock culture. A 1-ml culture was thawed in a water bath at 37°C and centrifuged for 10 min at 800 rpm to pellet the cells and to remove the freeze protection medium, DMSO. The supernatant was aspirated and the cells were resuspended in 10 ml of 20% FBS/DME medium in a sterile plastic petri dish and placed in an incubator (maintained at 37°C and 8% CO₂) for growth.

When the cells had grown to cover over 50% of the petri dish (approx. 3 days), they were transferred to a 250-ml sterile plastic bottle containing 20 ml of 10% FBS/DME medium and kept in an incubator.

After two days, the cells were washed and transferred to another fresh bottle containing 20 ml of 10% FBS/DME medium. The cells were left to grow until they had covered 50-70% of the bottles' bottom surface, at this point, they were ready for fusion.

2.2.2.5 Production of hybridomas

The critical stage in production of hybridomas is the fusion of two parental lines (myelomas + spleen cells) without causing more than minimal damage to the cells. The mechanism of cell fusion is complex, (involving cell agglutination, swelling and membrane fusion) and optimal conditions for the three processes are often at odds (Campbel, 1984). Membrane fusion and toxicity increases with an increase in PEG concentrations (30-50%) in a time period (2–10 min). A good fusion protocol should operate under these ranges compromising conflicting needs to achieve sufficient fusion while keeping cell damage at an acceptable level.

The adopted procedure was as follows:

1. Ten percent DME medium was adjusted to 50% PEG while warming slightly, 10% DMSO medium was added and the medium was kept at 37°C until use.
2. Thymus glands were extracted from two (4-week old) mice and crushed in a sterile petri dish containing 10 ml DME medium to release the cells. The resulting cell suspension was placed in sterile 10-ml Falcon tubes and centrifuged for 10 min at 800 rpm. The cell pellets were resuspended in 10 ml HAT medium and kept at 37°C.
3. The bottles containing myeloma cells (FOX-NY) growing in the logarithmic phase (section 2.2.2.4) were slightly tapped at the bottom. With the help of a pasteur pipette the cells were rinsed gently then filled in a 50-ml Falcon tube and centrifuged as above.
4. Lymphoblasts from the spleen of the immunized mouse were extracted in 10 ml DME medium in a similar manner as the thymus cells in (2) above. After centrifugation, the resulting pellet was dissolved in the 10 ml DME-myeloma cell suspension (3) above and centrifuged for 10 min at 800 rpm.
5. The tube containing the pelleted mixture of spleen and myeloma cells was immersed half way in a water bath at 37 °C. While gently stirring, the following solutions were added with a 5-ml pipett:
 - 1 ml 50% PEG solution, pipetted drop-wise over 1 min period
 - 1 ml DME medium, pipetted drop-wise over 1 min period

2 ml DME medium, pipetted drop-wise over 1 min period

6 ml DME medium, pipetted drop-wise over 3-5 min period

6. The 10 ml of the fusion cell suspension were mixed with 10 ml thymocyte suspension (feeder cells) and diluted to 60 ml with HAT medium. This suspension was transferred to 6 culture plates (96 wells, 100 µl/well) and incubated at 37°C.

2.2.2.6 Growth of hybridomas

Four days after the fusion, the cells were fed by adding (100 µl per well) HT medium (HAT without aminopterin). Seven days after fusion, the medium was removed by aspiration and 200 µl of a fresh HT medium added to the culture wells. Ten days after fusion, the culture supernatant was tested by TAS-ELISA for the presence of virus-specific antibodies.

2.2.2.7 Detection and selection of antibody-secreting hybridoma cells

For testing of culture supernatants of the 6 fusion plates a TAS-ELISA protocol was adopted. 18 ELISA plates were coated with IgG to ACMV diluted 1:1000 (v/v) in coating buffer and incubated at 37°C for 2 h. After the incubation, a blocking and washing step was carried out as described in section 2.3.3.3.

Extracts from (young) healthy and symptomatic cassava leaves infected with EACMV, UgV were homogenized in ELISA extraction buffer and loaded onto parallel wells of the coated ELISA plates and incubated overnight at 4°C.

The plates were washed and after removal of the washing buffer 180 µl of the culture supernatants were taken under sterile conditions from each cell culture well and dispensed as 60-µl aliquots into each well of the three parallel wells in which one of the three samples EACMV, UgV and healthy was trapped. The plates were incubated for 2 h at 37°C.

After washing, 100 µl of alkaline phosphatase rabbit-anti-mouse IgG conjugate, diluted 1:1000 (v/v) in conjugate buffer was added and incubated for 45 min at 37°C.

Hundred μl of p-nitrophenyl phosphate substrate, 1 mg/ml (w/v) in substrate buffer was then added. Positive reactions were assessed visually and spectrophotometrically at $A_{405\text{nm}}$ using an ELISA reader (section 2.3.3.2) after 30 min, 1h and after overnight incubation of the substrate.

All cell lines producing culture supernatants that reacted positive with sap from virus-infected leaf material and negative with sap of healthy plants were marked and their culture supernatant tested again after 2 days. The cell lines testing positive in the second round of assay were subcloned and retested after one week.

2.2.2.8 Cell cloning

Only primary cell cultures that produced antibodies resulting in specific reactions with infected plant sap were cloned. Cloning was done by serially diluting each culture in a 96-well plate to the extent that only one cell per well was assumed present. Primary cultures were diluted in the presence of thymocytes as feeder cells or, by adding 20 U/ml of interleukin 6 (IL-6), and incubating at 37°C. Thymocytes from one thymus gland were sufficient for 3-4 cloning experiments. The number of colonies per well was evaluated by light microscopy after the 4th and the 6th day. Only single-growing colonies per well were marked and grown further.

The following method of cloning was performed:

1. In the first well, at position A1 of a 96-well plate, 200 μl of 20% FBS/DME medium was added to 10 μl of a chosen primary culture (300-500 cells).
2. Hundred μl of the A1 dilution was transferred into well B1, 100 μl 20% FBS/DME medium was added and mixed well. This 1:1 dilution series was continued to well H1. The cells were allowed to settle for 30 min after which they were counted under a microscope.
3. One well from this series containing about 100 cells was selected and the cell suspension diluted further in 18 ml of 20% FBS/DME medium containing thymocytes or IL-6. 100 μl /well of this dilution was dispensed into the remaining wells of the plate and the cultures were subsequently incubated at 37 °C.

4. After the 4th and the 6th day, wells containing only one colony were microscopically examined and the cells were fed with 100 µl of 20% FBS/DME medium.
5. Cell culture supernatants of individual colonies were subsequently tested in TAS-ELISA as described in section 2.3.3.3.

2.2.2.9 Harvesting MAbs

MAbs were produced *in vitro* by culturing cell clones in the petri dishes as described above. When the cell density was above 70%, MAbs secreted into the spent culture medium were harvested by collecting culture supernatants which were subsequently centrifuged (800 rpm, 10 min) to remove cells and cell debris. Culture supernatants were stored at 4°C after adding 0.05% NaN₃ to prevent microbial growth.

2.2.2.10 Cryopreservation of cell cultures

For preservation of MAb secreting hybridoma cell lines, cells were harvested from 10-ml petri dish cultures when approximately 60 to 80% of the petri dish was covered with a cell layer. Cells were centrifuged for 10 min at 800 rpm, pellets were resuspended in 7.5-ml bottles containing 4 ml of 10% DMSO in FBS, and 1.5 ml of suspension were aliquoted into two 2-ml pre-cooled cryopreservation screw-top vials. The vials were kept overnight at -80°C and thereafter transferred into liquid nitrogen.

2.2.2.11 Naming of MAbs

For a clear denomination of hybridoma cells whose MAbs and source of parental cell lines is to be traced, the following naming scheme was adopted, e.g.,

EACMV-1-6E9-C9

| | |
|-------|--|
| EACMV | Immunogen |
| -1- | Fusion mouse number |
| -6E9- | Primary culture cells from the 6 th plate and well E9 |
| C9 | Subclone from well C9 |

Although each cell line was cloned at least twice, sometimes only the code for the primary culture was used for MAb denomination.

2.2.2.12 Concentration of MAbs from culture supernatants

To 13-ml culture supernatant an equal volume of saturated ammonium sulphate (50%) pH 7.4 was added drop-wise while stirring. After an additional 2 h stirring at room temperature, the mixture was centrifuged for 15 min at 8000 rpm and the pellet resuspended in 1 ml 0.5 x PBS. This was then dialyzed against 4 changes of 500 ml of 0.5 x PBS. To 1 ml MAb solution, 5 mg/ml BSA and 20 μ l of (20%) NaN₃ was added for stabilization prior to storage at 4°C.

2.3 Enzyme-linked immunosorbent assay (ELISA)

2.3.1 Preparation of IgG

Antisera AS-0421 was obtained from the DSMZ collection and γ -immunoglobulin (IgG) isolated from raw antiserum as follows:

One ml of antiserum was added to 9 ml of distilled water. While stirring 10 ml of saturated ammonium sulphate, (NH₄)₂SO₄, were added drop-wise and incubated for 1h at room temperature without further stirring. The serum proteins were then sedimented by centrifugation at 8000 rpm (Sorvall RC-SB) for 15 min at 4°C. The supernatant was discarded and the resulting pellet resuspended in 2 ml 0.5 x PBS (section 2.3) buffer. Residual (NH₄)₂SO₄ was dialyzed out of the solution by three dialysis changes (2 h, 2h, and overnight at 4°C) against 0.5x PBS buffer. The protein suspension was further fractionated in a DEAE-cellulose column prepared in

0.5x PBS. Absorption of the 1-ml fractions was measured at a wavelength (λ) of 280 nm. IgG-containing fractions with $A_{280\text{nm}}$ values greater than 0.5 were pooled and adjusted to 1 mg per ml ($A_{280\text{ nm}} = 1.4$) using 0.5x PBS. To every ml of IgG, 20 μl NaN_3 were added and stored at 4°C.

2.3.2 Labelling of IgG with alkaline phosphatase

For conjugation of IgG, the procedures described by Clark and Adams (1977) and Casper and Meyer (1981) were used as follows:

1. To one ml of purified IgG, 70 μl of alkaline phosphatase (Boehringer Mannheim, Germany) were added and dialysed for 5 h at room temperature against 300 ml of 0.5x PBS buffer containing 720 μl of 25% glutaraldehyde that was added drop-wise to the solution.
2. Excess glutaraldehyde was then removed from the coupling reaction by four dialysis exchanges of 500 ml of 0.5x PBS.
3. The contents of the dialysis bag was carefully removed and placed in a 1.5-ml microfuge tube. 5 mg of bovine serum albumin (BSA) and 20 μl of NaN_3 were added for stabilization and stored at 4°C.

To establish the optimal working dilutions for IgG for coating and for the detecting antibody conjugate, different dilutions of IgG and conjugate (1:200, 1:500, 1:1000 and 1:2000 v/v) were tested. Serial dilutions of sap homogenates of virus-infected and non-infected plants were prepared in ELISA sample extraction buffer and subjected to DAS-ELISA to select optimum reagent dilutions resulting in maximum detection sensitivity and minimum background reactions.

Buffers:

Phosphate buffered saline (PBS); 10x PBS pH 7.4 (per liter):

80.0 g NaCl

2.0 g NaN₃

2.0 g KCl

14.4 g Na₂HPO₄·2H₂O

2.0 g KH₂PO₄

dissolve in 800 ml distilled water, adjust pH, make up to 1 liter.

Coating buffer, pH 9.6 (per liter):

1.59 g Na₂CO₃

2.93 g NaHCO₃

0.20 g NaN₃

dissolve in 900 ml distilled water, adjust pH, make up to 1 liter.

Sample extraction buffer, pH 7.4 (per liter):

100 ml 10x PBS, pH 7.4

20 g PVP (w/v) 10,000 (M_r)

500 µl Tween 20

add up to 1 liter with distilled water.

Washing buffer-PBST (per liter):

100 ml 10x PBS, pH 7.4

500 µl Tween 20

make up to 1 liter with distilled water.

Conjugate buffer, pH 7.4 (per liter):

100 ml 10x PBS

500 µl Tween 20

20 g PVP 10,000 (M_r)

0.2 % egg albumin, make up to 1 liter with distilled water.

Substrate buffer, pH 9.8 (per liter):

97 ml Diethanolamine

0.2 g NaN₃

dissolve in 600 ml distilled water,

adjust pH with HCl, make up to 1 liter.

The alkaline phosphatase IgG conjugate was detected using the substrate, *p*-nitrophenyl phosphate (Sigma, N9389) at a concentration of 1mg/ml in 1M diethanolamine buffer pH 9.8.

2.3.3 ELISA formats

2.3.3.1 Sample preparation

For sample testing in ELISA, leaf tissues of virus-infected plants were ground 1:10 (w/v) in sample extraction buffer. This sap dilution was found most appropriate in optimisation tests used in the detection of phloem limited cassava begomoviruses. The uppermost youngest symptomatic cassava leaves were chosen, since virus titers were low to almost undetectable levels in lower older ones including those with pronounced mosaic symptoms.

2.3.3.2 Double antibody sandwich ELISA (DAS-ELISA)

DAS-ELISA was done essentially as described by Clark and Adams (1977).

For all ELISA tests, Microtiter plates (Greiner Microlon medium binding) were used and generally volumes for each reactant were kept at 100 µl/well.

Between incubations 3, intensive washing steps each lasting 3 min were carried out by repeated soaking of the plates in washing buffer.

1. For detection of cassava begomoviruses by DAS ELISA, microtiter plates were coated with ACMV IgG (AS-0421) diluted 1:1000 (v/v) in coating buffer and incubated for 2 h at 37°C.
2. Sap extracts were added and incubated overnight at 4 °C. Extracts from healthy plants and of plants infected with known begomoviruses were used as negative and positive controls, respectively.
3. IgG-alkaline phosphatase conjugate, diluted 1:1000 (v/v) in conjugate buffer, was added and incubated for 2 h at 37°C.
4. The substrate, p-nitrophenyl phosphate diluted 1 mg/ml in substrate buffer was added and incubated for 1 h and 2h at 37°C.

Quantitative measurements of the p-nitrophenol substrate conversion resulting in a yellow color was made by determining absorbance at 405 nm (A_{405}) in a Titertek Multiscan® MCC/340 model spectrophotometer (Labsystems Co., Finland). The mean absorbance readings of non-infected controls were determined and twice the values were used as the positive/negative thresholds.

2.3.3.3 Triple antibody sandwich ELISA (TAS-ELISA)

TAS-ELISA was conducted essentially as described by Thomas *et al.* (1986) with minor modifications.

1. Microtitre plates (96 wells) were coated with ACMV IgG diluted 1:1000 (v/v) in coating buffer and incubated for 2 h at 37°C.
2. After washing, blocking was done by adding 2% skimmed milk in PBST (200 µl/well) and incubating for 30 min at 37°C.
3. Sap extracts prepared as described in section 2.3.3.2 were added and incubated overnight at 4°C. Extracts from healthy plants and of plants infected with known begomoviruses were used as negative and positive controls, respectively.

4. Culture supernatants containing MAbs raised against TYLCV (Table 2) were used as detecting antibodies at dilutions in conjugate buffer 1:1 (v/v), 1:50 (v/v), 1:100 (v/v), 1:200 (v/v), 1:500 (v/v), and 1:1000 (v/v). MAbs raised against ACMV (SCR23 and SCR 33, Thomas *et al.* 1986) were diluted 1:1000 (v/v) in conjugate buffer and used as references.
5. 100 µl of each culture supernatant dilution were loaded onto microtiter plates and incubated for 2 h at 37°C.
6. After washing the plates, an alkaline phosphatase labeled, rabbit-anti-mouse IgG-ap, (DAKO A/S, Denmark) diluted 1:1000 (v/v) in conjugate buffer was added (100 µl/well) and the plates incubated for 45 min at 37°C.
7. Substrate addition, incubation and absorbance readings were as described above in section 2.3.3.2.

2.3.3.4 Tissue-blot immuno-assay (TBIA)

For detection and localisation of cassava begomoviruses in plant tissues, a modified method of the tissue blot assay developed by Lin *et al.* (1990) was used.

Nitrocellulose (NC) membranes (0.45 µm pore size, Schleicher and Schuell, Dassel, Germany) were marked with a waterproof pen into square grids equivalent to the size of plant material to be blotted. All manipulations and incubations were done at room temperature with agitation.

1. Just before blotting, the membranes were wetted briefly in a 2.5% Na₂SO₃ solution.
2. CMD-infected cassava plants from Kenya, Uganda, Zambia, the Democratic Republic of the Congo and Nigeria and, *N. benthamiana* plants mechanically inoculated with cassava begomoviruses were examined.
3. Fresh plant tissue (stems, sprouts, petioles) was cut with a sharp blade (disinfected with 70% alcohol after every cut) and cut surfaces immediately pressed firmly but gently onto the membrane.

4. After all the samples were blotted, protein-binding sites on the membranes were blocked by immersing membranes in PBS buffer containing polyvinyl alcohol (PVA) 72000 (Merck, 821038) at a concentration of 1 µg/ml for 1 min.
5. The membranes were then washed for a few seconds in PBST after which a detecting MAb (4F10, 1C1, 5D8, or 1H2) diluted 1:200 (v/v) in conjugate buffer was added and incubated for 1h and then washed twice (each time 10 min) in PBST.
6. AP-labelled rabbit-anti-mouse diluted 1:1000 (v/v) in ELISA conjugate buffer was then added and the membranes incubated for 45 min.
7. After a final washing step, the membranes were pre-equilibrated for 5 min in Tris-buffered saline (TBS, 0.2 M Tris-HCl, pH 8.0, 2.0 mM MgCl₂).
8. For colorimetric detection, the membranes were developed for 10 min in a freshly prepared substrate mixture (1:1 v/v) of solution A [Naphtol-AS-MX phosphate sodium salt (Sigma, N500) in distilled water, 6 mg/15ml] and solution B [Fast Red TR-salt (Sigma, F2768) in TBS, pH 8.6, 90 mg/15 ml].
9. The reaction was continued until the development of distinct red color and/ or spots appeared, the substrate solution was quickly exchanged with water and the membrane dried between Whatman 3MM paper.

For interpretation of the results the membranes were observed under a dissecting microscope (Stemi 2000-C, Zeiss, Germany).

2.4 Protein analysis

2.4.1 SDS-polyacrylamide gel electrophoresis (SDS-PAGE)

To determine the molecular weights of the structural coat proteins of cassava begomoviruses, samples from virus-infected plants or partially purified virus preparations were analysed by SDS-polyacrylamide gel electrophoresis (PAGE) using a 12 % polyacrylamide gel. The putative capsid protein size was estimated by comparison with protein bands of a molecular weight marker (Amersham Pharmacia Biotech, Cat. No. 17-0446-01), phosphorylase b 94,000; albumin

67,000; ovalbumin 43,000; carbonic anhydrase 30,000; trypsin inhibitor 20,100; alpha lactoalbumin 14,400 that was separated in parallel to the virus samples in each gel.

Solutions for SDS-PAGE

30% Polyacrylamide stock solution

(29 g acrylamide, 1g N´N´bis acrylamide dissolved in 100 ml of distilled water and kept at 4°C in the dark)

Resolving gel buffer (4x): 1.5 M Tris- HCl, pH 8.8

Stacking gel buffer (4x): 1 M Tris-HCl, pH 6.8

10% (w/v) sodium dodecylsulphate (SDS)

10% (w/v) ammonium persulphate (APS)

TEMED: N,N,N´,N´-tetramethylethylenediamine

2x sample buffer, pH 6.8, (Laemmli, 1970):

| | |
|---------------------|---------|
| 10% SDS | 12.5 ml |
| Stacking gel buffer | 20.0 ml |
| Glycerol | 10.0 ml |
| 1% bromophenol blue | 2.5 ml |
| Mercaptoethanol | 5.0 ml |

Electrophoresis buffer

25 mM Tris base, 192mM glycine,0.1%(w/v) SDS, pH 8.3.

Staining solution (Coomasie):

| | |
|------------------------------------|--------|
| 0.25% Coomasie brilliant blue R250 | 1 g |
| 50% methanol | 200 ml |
| 10% glacial acetic acid | 40 ml |
| distilled water | 160 ml |

Destaining solution (per liter):

| | |
|--------------------------|--------|
| 25 % methanol | 250 ml |
| 10 % glacial acetic acid | 100 ml |
| distilled water | 650 ml |

Solutions for preparing 12 % resolving gels and 5 % stacking gels for SDS- PAGE

| Solution | 20 ml Resolving gel (12%) | 5 ml Stacking gel (5%) |
|---------------------------|---------------------------|------------------------|
| Distilled water | 6.6 ml | 3.4 ml |
| 30% acrylamide | 8.0 ml | 0.85 ml |
| Resolving gel buffer (4x) | 5.0 ml | - |
| Stacking gel buffer (4x) | - | 0.625 ml |
| 10% SDS | 200 μ l | 50 μ l |
| 10% APS | 200 μ l | 50 μ l |
| TEMED | 8 μ l | 5 μ l |

Using a dual gel caster (Mighty Small™ SE 245, Amersham Pharmacia Biotech, Freiburg, Germany), solutions for the resolving gel were mixed carefully (without introducing air bubbles) and immediately poured between the glass plates and overlaid with 2 ml distilled water. When polymerization was complete (approx. after 30 min.) the water overlay was poured off and the gel well drained using Whatmann 3MM paper. A comb used to form gel slots was inserted and solutions for the stacking gel mixed and poured on top of the resolving gel. The stacking gel was allowed to polymerize for 20 min. The comb was removed and the gel carefully washed with distilled water to remove unpolymerised gel solution. The gel plates were subsequently detached from the caster and fixed to the gel apparatus to form upper and lower buffer chambers, which were filled with cold electrophoresis buffer.

Sample preparation and electrophoresis conditions

1. Leaf material from virus-infected and non-infected control plants were ground 1:10 (w/v) in ice cold protein extraction buffer (50 mM Tris, 5 mM boric acid, 5% glycerin, 1.5% polyclar AT, 0.01% mercaptoethanol, pH 8.0).
2. The homogenate was transferred to 1.5-ml reaction vials and centrifuged at 13,000 rpm for 30 s to pellet plant debris.

3. 50 µl of each supernatant containing the soluble leaf protein fraction was aliquoted and an equal volume of 2x Laemmli sample loading buffer added.
4. Partially purified virus preparations were mixed (1:1 v/v) with the 2x sample-loading buffer.
5. To denature the proteins, samples were boiled for 6 min and immediately placed on ice until use.
6. 20 µl of each sample to be analysed was loaded on gels (10 cm long x 8 cm wide x 2 mm thick) and the respective protein molecular weight marker was loaded onto lane 1 and 10.
7. Gel electrophoresis was conducted at 100 volts in a vertical gel electrophoresis apparatus (Mighty Small II, Amersham Pharmacia Biotech, Cat.No.: 17-0446-01) for about 1.5 h or until the bromophenyl blue dye had migrated to the bottom of the gel.

At the end of the electrophoresis, the gel was carefully removed from the glass plates and stained by soaking in the staining solution for 20 min with gentle agitation. Excess stain was then removed by immersing the gel for 1 h in several changes of the destaining solution each lasting 15-20 min.

2.4.2 Electro-blot immunoassay (EBIA) / Western-blot

For serological detection of the viral coat proteins, the electrophoretically separated proteins needed to be transferred (electro-blotted) onto polyvinylidene difluoride (PVDF) membranes. The method is particularly useful for identification and quantification of specific proteins in a complex mixture of proteins.

This technique, also known as Western blot, was conducted essentially following the methods of Towbin *et al.* (1979) and Burnette (1981).

2.4.2.1 Protein transfer to polyvinylidene difluoride (PVDF) membranes- Electroblotting

Solutions:

Western blot transfer buffer (per liter):

| | |
|---------------|-----------------------------|
| 48 mM Tris | 5.81 g |
| 39 mM glycine | 2.93 g |
| 0.0375 % SDS | 3.75 ml of 10% SDS solution |
| 20% methanol | 200 ml |

make up to 1 liter with distilled water.

Amido black staining solution (per 0.5 liters):

| | |
|---|--------|
| 45 % ethanol | 225 ml |
| 10 % acetic acid | 50 ml |
| 0.1 % amido black 10B (E. MERCK AG, Darmstadt, Cat. No.2047) | 0.5 g |
| distilled water | 225 ml |

Amido black destaining solution (per 0.5 liters):

| | |
|------------------|-----------------------|
| 25 % isopropanol | 125 ml |
| 10 % acetic acid | 50 ml |
| 0.1 % SDS | 5 ml of 10 % solution |
| distilled water | 320 ml |

SDS – Page was carried out to separate proteins in a 12% polyacrylamide gel as described in section 2.4.1.

After electrophoretic separation of proteins, the glass plates sandwiching the gel were removed, and the gel carefully rinsed in transfer buffer.

Prior to electrophoretic transfer, the PVDF-membrane (Milipore, 0.45 μ m pore size, P15374, Bedford, MA, USA) was cut to size of the gel, briefly soaked in methanol and then put in a sandwich assembled in the western blot transfer cassette (Pharmacia Biotech, code No. 80-6204-64, San Francisco, CA, USA) as follows:

Anode

Sponge (porous) pad

2 Whatman 3 MM paper

PVDF membrane

Gel

2 Whatman 3 MM paper

Sponge (porous) pad

Cathode

The assembly was done carefully and under submersion in transfer buffer, not to introduce air bubbles in between the sandwich layers.

The transfer cassette was carefully placed in the vertical transfer chamber (Amersham Pharmacia Biotech, Freiburg, Germany) that was filled with cold transfer buffer. The electro-transfer of the separated proteins from the gel to the membrane was accomplished by applying maximum voltage and approximately 400 mA for 1.5 h with cooling.

2.4.2.2 Immunological detection of viral coat proteins

After completion of the blotting, the gel was discarded and the marker lane was cut off the membrane and developed separately in amido black staining solution.

1. The remaining membrane was placed overnight at 4°C in ELISA blocking buffer containing 2% skimmed milk, to block the unspecific protein binding sites on the membrane.
2. The membrane was washed by soaking in ELISA washing buffer (section 2.3.3.2) 2 times each for 10 min. ACMV IgG (AS-0421) diluted 1:1000 (v/v) in ELISA wash buffer was added (10 ml/membrane) and incubated with gentle agitation for 2 h at room temperature.
3. The membrane was washed as in the previous step and goat anti-rabbit IgG-AP conjugate diluted 1:1000 (v/v) in wash buffer (10 ml/membrane) added and incubated with gentle agitation for 1 h at room temperature.

4. The membrane was washed in ELISA wash buffer, rinsed in water and equilibrated with 10 ml NBT/BCIP substrate buffer (100 mM NaCl, 5 mM MgCl₂, 100 mM Tris-Cl, pH 9.5) for 10 min at room temperature.
5. The membrane was transferred to another tray containing freshly mixed 66 µl NBT (Promega, s380c 4930511) and 33 µl BCIP (Promega, s381c 7985703) in 10 ml substrate buffer and incubated with agitation at room temperature for a few min until the desired intensity of the bands was attained.
6. To stop the substrate conversion reaction, the membrane was dipped in distilled water for a few seconds and dried between two pieces of Whatman 3MM paper.

2.5 Electron Microscopy (EM)

Buffers and solutions:

Buffer 1: 0.1 M Na/K- phosphate buffer, pH 7.0

Buffer 2: 0.1 M Na/K-phosphate buffer, pH 7.0 containing 2% PVP (w/v) and 0.2% Na₂SO₃ (w/v)

Buffer 3: 0.1 Na/K- phosphate buffer, pH 7.0, containing 0.05% NaN₃

Staining solution: 1% Uranyl acetate (UAc) in distilled water, pH 4.3

2.5.1 Adsorption preparations

Leaf samples were ground in Buffer 2 and drops of the resulting extract were placed on a piece of parafilm. Pioloform-coated and carbon stabilized Nickel grids were floated on the leaf extracts or on drops of purified virus for 5 min, washed with 40 drops of distilled water and stained with 5 drops of 1% UAc staining solution.

2.5.2 Immunosorbent electron microscopy (ISEM)

This technique, developed by Derrick (1973), involved trapping of virus particles from a suspension by a specific antibody that is coated on the grid. The virus particles become selectively attached to the grid whereas the unbound host plant material is easily removed by a subsequent washing step (Dijkstra and de Jager, 1998).

ISEM was conducted essentially as described by Milne and Lesemann (1984). Nickel grids were incubated for 5 min on drops of ACMV antiserum diluted 1:1000 (v/v) in buffer 3. After washing with 20 drops of buffer 1, the grids were floated onto leaf extracts or purified virus preparations for 3 h at room temperature. After washing with 40 drops of distilled water, grids were negatively stained with 5 drops of 1%UAc.

All EM preparations were viewed in a Zeiss TEM 906 transmission electron microscope.

2.6 Nucleic acid analysis

2.6.1 Extraction of total DNA from virus-infected leaves

Total DNA was extracted from plant tissues using either a plant DNA minipreparation method (Dellaporta *et al.*, 1983) or a modification of the CTAB method developed by Murray and Thompson (1980). The latter procedure was only used in cases where large quantities of DNA were required.

The Dellaporta method

1. Fresh leaf tissue (100 - 150 mg) harvested in a polythene sample bag was shortly placed in liquid nitrogen and then crushed in 1 ml extraction buffer (100 mM Tris-HCl, pH 8, 50 mM EDTA, 500 mM NaCl, 1% 2-mercaptoethanol and 10 µl of RNase A, 10 mg/ml) using a wallpaper roller and 500 µl aliquot of the homogenate transferred to a 1.5-ml microfuge tube.
2. Thirty-three µl of 20% SDS were added to the homogenate and incubated for 10 min at 65°C.

3. Hundred and sixty μl (0.25 vol.) of 5 M potassium acetate were immediately added, the mixture vortexed thoroughly and then centrifuged for 10 min at 13,000 rpm at room temperature.
4. About 400 – 450 μl of clarified supernatant were carefully transferred to a new tube and 0.5 vol. isopropanol added, vortexed and centrifuged for 10 min at 4°C to precipitate nucleic acids.
5. Isopropanol was carefully decanted and DNA pellets washed with 500 μl of 70% ethanol by centrifugation for 5 min at 13,000 rpm at 4°C.
6. The final DNA pellet was air dried at 37°C and resuspended in 100 μl of distilled water.

The CTAB method

Extraction buffer:

- 10 mM Tris, pH 7.4
- 150 mM NaCl
- 50 mM EDTA
- 0.5% 2- β -mercaptoethanol

Adjust buffer:

- 10% CTAB (Hexadecyltrimethylammonium bromide)
- 0.5 M Tris, pH 8.0
- 0.1 M EDTA

1. Plant leaves were ground in liquid nitrogen using a motor and pestle and homogenized in extraction buffer (20 ml/g leaf tissue).
2. To the slurry, 100 μl of 20 mg/ml proteinase K was added and incubated for 15 min on ice while stirring.
3. The mixture was transferred to a new tube, adjusted to 2 % SDS and incubated at 65°C for 35 min. To pellet cell debris, the homogenate was centrifuged for 10 min at 10,000 rpm at room temperature.

4. The supernatant was adjusted to 1.4 M NaCl before adding 0.1 volume of Adjust buffer and then adjusting it to 1% RNase A (20 mg/ml). This was then incubated at 65°C for 10 min and allowed to cool on ice for 15 min.
5. To further denature plant cell constituents and release nucleic acid, supernatants were washed twice with an equal volume of chloroform and centrifuged at 10,000 rpm for 10 min.
6. Total nucleic acids were precipitated by addition of 0.8 vol. isopropanol followed by incubation on ice for 30 min and centrifugation at 10,000 rpm for 20 min at 4°C.
7. The final pellets were washed with 70% ethanol, dried at 37°C for 5 min and resuspended in appropriate amount of sterile bi-distilled water.

2.6.2 Quantification of DNA

2.6.2.1 Spectrophotometric determination

DNA was quantified by taking spectrophotometric absorbance (A) readings at wavelengths (λ) of 260 and 280 nm. Readings at 260 nm allowed calculation of nucleic acid in the sample (Sambrook *et al.*, 1989) whereby, an A_{260} of 1 corresponds to approximately 50 $\mu\text{g/ml}$ for dsDNA and to 40 $\mu\text{g/ml}$ of ssDNA and RNA. The $A_{260\text{nm}}/A_{280\text{nm}}$ ratio provides an estimate of the purity. Pure preparations of DNA and RNA have $A_{260\text{nm}}/A_{280\text{nm}}$ of 1.8 and 2.0, respectively but contaminations with protein or phenolic substances will significantly lower these ratios.

2.6.2.2 Agarose gel electrophoresis

In cases where either the quantity of DNA was not sufficient (<250 ng/ml) to be spectrophotometrically assayed, the amount of DNA was estimated rapidly in the agarose gel directly after electrophoresis. This method utilizes the ultraviolet-induced fluorescence emitted by ethidium bromide molecules that are intercalated into the DNA. Since the amount of fluorescence is proportional to the total mass of DNA, the quantity of DNA can be estimated by comparing the fluorescence of the sample with that of the standards.

Electrophoresis buffer (TAE):

0.04 M Tris acetate, pH 8.0

1 mM EDTA

Sample buffer:

25% Ficoll

25% Bromophenol blue in 5x TAE.

For the analysis of total DNA preparations from plants, PCR amplicons or plasmid DNA, standard 1% agarose gels prepared in TAE electrophoresis buffer were used. Agarose powder was added to a TAE buffer (1% w/v) and microwaved for 2 min to dissolve the powder. To the cooling solution, 0.005% ethidium bromide was added and the solution subsequently poured into a tray in which a comb was inserted to form sample slots. The agarose gel was allowed to solidify for approximately 30 min before the comb was removed and the gel immersed in the electrophoresis tank containing TAE buffer.

To 3-10 μ l of DNA sample, 3 μ l of sample buffer were added and the total volume (6-13 μ l) loaded into a slot in the gel. The gel was run at 120 volts and maximum current for 45 min before being viewed under UV light and photographed.

In most experiments, a λ Pst I digested phage DNA (Fermentas NBI, Germany) was used as a molecular size marker that was run in parallel i.e. in one lane of each gel.

2.6.3 Preparation of tissue-prints and plant sap dot-blot

Membranes:

Boehringer (Nylon membranes, positively charged, Cat.: 1209299)

Solutions:

20x SSC (per liter):

3 M NaCl 175.3 g
0.3 M tri-Na-Citrate ($C_6H_5Na_3O_7 \cdot 2H_2O$) 88.2 g
dissolve in 800 ml distilled water
adjust to pH 7.0 with 1 N NaOH
make up to 1 liter with distilled water

20% SDS:

20 g sodium dodecylsulphate (SDS)
70 ml water
dissolve by warming
make up to 100 ml with water

Denaturation buffer

1.5 M NaCl
0.5 M NaOH

Neutralization buffer

1.5M NaCl
0.5 M Tris
0.001 M Na_2EDTA , pH 7.5.

For nucleic acid dot-blot preparation, fresh tissue was ground in extraction buffer (6x SSC) and 10 μ l of each sample corresponding to 10 mg fresh tissue spotted onto nylon membranes using a micropipette.

For tissue printing, plant shoot tissues were applied onto the membrane as described for the TBIA procedure (section 2.3.3.5).

After the application of the sap dots and tissue prints, membranes were washed for 5 min in a solution containing 2x SSC and 0.1% SDS followed by a 5 min incubation in 2x SSC.

Thereafter DNA on membranes was denatured for 10 min in denaturation buffer followed by a 5 min step in neutralization buffer. Membranes were subsequently washed briefly in 2x SSC and DNA was fixed by a UV crosslinking at a wavelength of 254 nm and 1200 joules.

Membranes were dried, and either stored in the dark at room temperature or directly used for hybridization.

2.6.4 Preparation of DNA probes

Radiolabelling of DNA-A clone pBSk011 (ACMV) and pBSk002 (UgV) was done using the Megaprime™ DNA labelling systems kit (Amersham Life Science, England) according to the manufacturer's recommendations as follows:

Reaction mix:

2 µl (20 ng) plasmid DNA

5 µl H₂O

5 µl primer

boil at 95°C for 5 min and spin, then add

10 µl labelling buffer

2 µl DNA polymerase I Klenow

23 µl H₂O

3 µl [α -³²P]dCTP

Incubate reaction mix at 37°C for 30 min and then stop reaction by addition of 5 µl 0.2 M EDTA

Prior to hybridization, the probe solution was denatured by heating at 95°C for 5 min and chilled on ice. The probe was added directly to 15 ml of hybridization solution.

2.6.5 DNA hybridization and autoradiography

Solutions:

Pre-and Hybridization solution:

50 % (v/v) formamide

5 % (v/v) SDS

5x SSC

50 mM sodium phosphate buffer, pH 7.2

For DNA hybridization, the nylon membranes were carefully placed in a hybridization tube and 15 ml of pre-hybridization solution added in order to completely submerge the membranes. Pre-hybridization was done for 90 min at 42°C by slowly rolling the hybridization tubes. The hybridization solution was removed and a fresh one added. The radioactive labelled DNA probe (25-40 ng labelled PCR product /ml solution) was boiled for 5 min at 95°C and added directly to the fresh hybridization solution. Hybridization was done overnight at 42°C with gentle rolling of the hybridization tubes to submerge DNA bound on the membranes. The DNA hybridization solution was removed and post hybridization washes conducted.

To remove DNA probe which was unspecifically bound, membranes were washed 2 x each for 15 min at room temperature in 2x SSC, 0.5% SDS followed by 2 x washing in 0.5x SSC, 0.5% SDS and subsequently, in a high stringency step, by washing the membranes 2 x each for 15 min in 0.1x SSC, 0.5% SDS at 65°C.

For autoradiographic detection of labelled DNA/DNA hybrids, membranes were wrapped in sheets of transparencies and placed in a light tight cassette (Agfa Curix MR 800). In the dark, an X-ray film (Curix, Agfa or Hyperfilm MP, Amersham) was placed on the top side of the membrane before the cassette was closed and exposed overnight at -80°C.

After exposure, the X-ray film was removed from the cassette in the darkroom and developed using standard photographic procedures.

2.6.6 Detection of begomovirus DNA-A genomic sequences by Polymerase chain reaction (PCR)

For detection and differentiation of cassava begomoviruses, ACMV, UgV, and EACMV in single and, in mixed virus infections, a polymerase chain reaction (PCR) approach was followed. Published sequences available at GenBank and the European Molecular Biology Laboratory (EMBL) were compared for DNA-A genomic sequences of ACMV Nigeria (Gen1G), ACMV Western Kenya (Ge1G), UgV (CVUV39) and EACMV Tanzania (EACMVT). Primers used to detect viral DNA-A in cassava are shown in Table 3. Seven primers with unique sequences to each virus were used to discriminate the virus types. Two primers, Begomo 146 and 672, from sequences that are common to all cassava (and most) begomoviruses were included for virus detection purposes. Depending on the virus to be detected, primer combinations shown in Table 4 were used.

Table 3. Primers used to detect viral DNA-A fragments in cassava samples from Africa

| Primer | Sequence (5' → 3') | Strand | Target |
|--------------|---------------------------|---------------|--------|
| ACMV AL1/F* | gcggaatccctaacattatc | Sense | AL1 |
| ACMV ARO/R* | gctcgtatgtatcctctaaggcctg | Complementary | AR2 |
| EACMVT588U20 | cactggtatgggccgatgtg | Sense | CP |
| UV ECO/CP | gaattcctaattgtcactgcat | Complementary | CP |
| UV CP/R* | gttacggagcaacatgcaat | Complementary | CP |
| UV AL1 /F1* | tgtcttctgggacttgtgtg | Sense | AL1 |
| UgV1129L20 | cactacaagttacggagcaa | Complementary | CP |
| Begomo 146 | taatattacckgwkgvccsc | Sense | AR2 |
| Begomo 672 | tggacyttrcawggbccttcaca | Complementary | CP |

* Primers designed by Zhou *et al.* (1997)

Table 4. Primer combinations and annealing temperatures used for detection of different begomoviruses in cassava

| Virion primer | sense | Complementary primer | Annealing Temperature | Virus detected |
|------------------|-------|----------------------|-----------------------|----------------|
| 1. ACMV AL1/F | | ACMV ARO/R | 52°C | ACMV |
| 2. EACMV T588U20 | | UV ECO/CP | 55°C | EACMV |
| 3. UV AL1/F1 | | UgV 1129 | 52°C | UgV |
| 4. BEGOMO 146 | | BEGOMO 672 | 52°C | begomoviruses |

One μl of total DNA (section 2.6.1) was subjected to PCR in a total volume of 50 μl . The reaction consisted of 2.5 μl MgCl_2 (50 mM), 1 μl of each primer (100 pmol), 5 μl of 10x *Taq* polymerase buffer, 1 μl dNTPs (25 mM) and 0.5 μl (2.5 units) of *Taq* DNA polymerase (GIBCO BRL). After an initial denaturation step of 3 min at 95°C, 35 amplification cycles followed with 1 min denaturation at 95°C, 1.5 min primer annealing at temperatures specified for the respective primer combinations (Table 4), and 1 min strand extension at 72°C. PCR amplification was terminated by a final extension period of 10 min at 72°C.

The predicted length of the DNA amplified by the primer combination 1 is 975 bp, of 2 and 4 is 520 bp and that of 3 is 1800 bp.

To determine the presence and size of the PCR products, 10 μl of the cycled PCR reaction mix were analyzed by electrophoresis in 1% agarose gels (section 2.6.2.2).

2.7 Nucleic acid manipulations

2.7.1 Cloning begomovirus genome fragments and full-length DNA-A and DNA-B genomic components

2.7.1.1 Growth media and buffer solutions

All media, solutions and distilled water used were sterilized and either supplied in kits, prepared and autoclaved (121°C, 1 bar, 30 min) or, filter sterilized (pore size 0.2 µm).

LB-medium (per liter):

10 g Tryptone

5 g Yeast extract

10 g NaCl

adjust pH to 7.5 with 1N NaOH

LB-agar plates (per liter):

10 g Tryptone

5 g Yeast extract

10 g NaCl

15 g BiTek™-agar

adjust pH to 7.5 with 1N NaOH

make up to 1 liter with distilled water.

After autoclaving and just before pouring onto plates, antibiotics were added as required (e.g. 100 mg/l Ampicilin or 30 mg/l Kanamycin).

SOB-medium (per liter):

2% Tryptone 20 g

0,5% yeast extract 5 g

10 mM NaCl 0.58 g

2.5 mM KCl 0.2 g

adjust pH to 7.0 with NaOH

2 M Mg⁺⁺ stock solution (100 ml):

MgCl₂·6H₂O 20.3 g

MgSO₄·7H₂O 24.6 g

dissolve in water and adjust volume to 100 ml

SOC-medium (per ml):

980 µl SOB

10 µl of 2 M Mg⁺⁺

10 µl of 2 M Glucose

Transformation buffer (TFB):

0.1 M RbCl

0.045 M MnCl₂

0.01 M CaCl₂

0.003 M Hexamin-CoCl₃

0.01 M KOH-MES, pH 6.3

filter sterilize

DTT: 2.25 M Dithiothreitol

in 0.004 M KAc, pH 6.0

DND (10 ml):

1.53 g DTT

9 ml DMSO

100 µl 1 M KAc

store at -20°C in 300 µl aliquots

DMSO: Dimethylsulfoxide

2.7.1.2 Enzymes, plasmid vectors and preparation kits

All laboratory chemicals restriction enzymes and buffers were obtained from GIBCO BRL, Roche, Promega and Fermentas MBI.

The Qiaex® II DNA gel extraction kit and the plasmid mini/ maxi kits (Qiagen, Hilden, Germany) were utilized for purification of dsDNA fragments from agarose gels and for plasmid preparations respectively.

For all general cloning purposes, the phagemid pBluescript II SK- (Stratagene) was used, whereas for initial cloning of PCR products, the T-tailed vector pGEM-T (Promega) was employed.

The bacterial strains *Escherichia coli* JM 109 (Promega) or DH 5 α cells (GIBCO BRL) were used as transformation hosts for propagation of foreign DNA in the above stated plasmids.

2.7.1.3 Amplification and cloning of coat protein genes

Total plant DNA was extracted from cassava plants infected with specific begomoviruses, ACMV, EACMV or UgV by using DNA extraction methods as described in section 2.6.1.

Coat protein genes of the respective viruses and/ or isolates were then amplified using the primer UV *Bam*HI CP (5'-ACG TGG ATC CAT GTC GAA GCG ACC AGG AGA T-3') as the upstream, sense primer and, ACM *Xba*I (5'-TGT TTC TAG ATT GCC AAT ACT GTC ATA-3') or UV *Eco*RI CP (5'- GAA TTC TTA ATT TGT CAC TGC AT -3') as the downstream complementary primer (Table 5).

PCR was done essentially as described in section 2.6.6 and 10 μ l of each cycled PCR reaction were subjected to agarose gel electrophoresis to check for the presence of amplified coat protein fragments under UV light.

Table 5. Primer combinations used to amplify cassava begomovirus coat protein genes.

| Virion sense primer | Complementary primer | Annealing temperature | Virus amplified |
|------------------------|----------------------|-----------------------|-----------------|
| 1. UV <i>Bam</i> HI CP | ACM <i>Xba</i> I | 52°C | ACMV |
| 2. UV <i>Bam</i> HI CP | UV <i>Eco</i> RI CP | 55°C | EACMV |
| 3. UV <i>Bam</i> HI CP | UV <i>Eco</i> RI CP | 52°C | UgV |

2.7.2 Cloning of coat protein genes in the pBluescript II SK- plasmid vector

To prepare compatible ends for cloning, PCR products of the expected size and pBluescript II SK- vector DNA was restriction digested in separate reactions as follows:

Digestion reaction

30µl DNA (PCR reaction) or approx. 5 µg vector

6µl React 3 buffer (Gibco BRL)

2µl *Eco*RI or *Xba* I

2µl *Bam*HI

adjust to 60 µl total volume with sterile distilled water

After incubation for 2 h at 37°C, DNA was separated by electrophoresis in a 1% agarose gel and visualized under UV light. The respective PCR fragments (inserts) and prepared vectors were excised from the gel and purified using the Qiaex® II kit according to the manufacturers recommendations.

Aliquots of the purified insert and vector fragments were again checked for integrity and DNA quantification prior to the ligation.

To ligate insert into vector DNA fragments with compatible ends for directional cloning, T4 DNA ligase was added to a ligation reaction as follows:

Ligation mix:

6µl digested DNA fragment (approx. 300 ng)

3µl prepared vector (approx. 50 ng)

2µl T4- DNA ligase buffer (10x)

8µl H₂O

1µl T4-DNA ligase

incubate overnight at 4°C

2.7.3 Cloning of PCR fragments in pGEM-T

To directly clone PCR fragments without prior plasmid or extensive PCR product manipulations, pGEM-T plasmid (Promega, linearized at the *Eco* RV site and T-tailed by the manufacturer) was used as a vector.

Although PCR dsDNA products amplified by the use of Taq polymerase already carry a 3' -A overhang, an additional A-tailing reaction was carried out to increase the number of 3' -A tail.

A-tailing was accomplished by a Taq polymerase incubation of the PCR fragment prior to cloning as follows:

A-tailing reaction mix:

2.5 µl distilled water

4 µl DNA insert

1 µl 10x Taq pol. Buffer

1 µl dATP (10 mM)

0.5 µl MgCl₂

1 µl Taq polymerase

10 µl (incubated at 72°C for 30min)

Two µl of the above reaction mix were used in the ligation reaction below.

Ligation mix:

2µl DNA A-tailed reaction mix (approx. 300 ng insert)

2µl pGEM-T vector (approx. 100 ng)

2µl T4- DNA ligase buffer (10x)

13µl H₂O

1µl T4-DNA ligase

20 µl incubated overnight at 4°C

2.7.4 Preparation of competent cells, DND method (Hanahan, 1983)

1. A day before transformation, *E.coli* JM109 cells from a bacterial stock culture were thawed, streaked on an LB-agar plate and incubated overnight at 37°C.
2. A few colonies were picked and each was resuspended in 1 ml SOB-medium and added to a 2-liter Erlenmeyer flask containing 30 ml SOB and 300 µl 2 M Mg⁺⁺.
3. Bacterial cells from (2) above were then incubated at 37°C with vigorous shaking at 125 rpm for about 1-1.5 h until A_{550nm} reached between 0.45 – 0.55.
4. The flask was then placed on ice for 15 min to stop cell division. To harvest cells, the slurry was transferred to 30 ml sterile ice cold Corex centrifuge tubes, which were then placed on ice for 10 min and then centrifuged at 3000 rpm at 4°C.
5. The pellet was resuspended in 10 ml TFB buffer by gentle shaking and then incubated on ice for 10 min and centrifuged again as above.
6. The pellet was again carefully resuspended in 4 ml TFB buffer and incubated on ice for 10 min.
7. To the cell suspension, 140 µl DND were added and incubated on ice for 15 min after which another 140 µl of DND were added and the mixture again kept on ice for another 15 min.
8. Competent bacterial cells were used directly for transformation.

For cloning of full length DNA-A and -B genomic components, bacterial cells of higher competence were required. Hence MAX EFFICIENCY DH 5 α cells (GIBCO BRL) reaching $>1 \times 10^9$ transformants/ μg DNA and library efficiency JM 109 cells (Promega) were bought competent for transformation and kept at -80°C until use.

2.7.5 Transformation of *Escherichia coli*

Transformation:

1. 200 μl of competent cells (or 50 μl of ready made competent cells) were added to an ice cold 1.5-ml microfuge tube.
2. 2-3 μl of each ligation reaction were mixed with the cells by gently swirling the suspension before incubating on ice for 30 min.
3. As a transformation control, 1 μl of uncut vector DNA was added to a similar tube containing competent cells.
4. Each transformation reaction was heat shocked in a 42°C water bath for 45 sec and immediately incubated on ice for 2 min.
5. Eight hundred μl (or 950 μl) of SOC were added to the cells and incubated for 1 h at 37°C with agitation at 125 rpm.
6. Two hundred μl of each transformation reaction were streaked onto A/X-agar plates (containing 100 mg/l ampicillin, 47 mg/l IPTG and 40 mg/l X-gal) and incubated (plates upside down) overnight at 37°C .

2.7.6 Plasmid preparations

2.7.6.1 Extraction of plasmid DNA from *E. coli*

Solution A: 25 mM Tris-HCl, pH 8.0
50 mM Glucose
10 mM EDTA

Solution B: 200 mM NaOH
1 % (w/v) SDS

Solution C: 3 M NaAc pH 4.8

Solution D: 0.1 M NaAc pH 7.0

0.05 M tris-HCl, pH 8.0

The extraction of recombinant plasmid DNA from the bacterial cells also called “minipreparation” was performed by the alkaline lysis method (Birnboim and Doly, 1979) as follows:

1. Clones carrying an insert were identified by blue/white screening. Single white bacterial colonies formed by bacteria whose lacZ genes had been interrupted by insertion of a DNA fragment were picked and inoculated into 3-ml LB-medium containing 100 mg/l ampicillin and incubated (at 37°C, 125 rpm) overnight.
2. Bacteria were harvested by centrifuging 2 ml of the cell suspension at 13,000 rpm for 2 min at room temperature.
3. Cell pellets were resuspended completely (leaving no cell clumps) in 200 µl solution A and incubated at room temperature for 10 min.
4. Four hundred µl of solution B and 300 µl of solution C were then added, mixed gently but thoroughly and the suspension incubated on ice for 30 min.
5. To pellet cell debris, cells were centrifuged at 13,000 rpm for 10 min at room temperature. The supernatant was placed in a new microfuge tube and recentrifuged.
6. Plasmid DNA in the supernatant was precipitated by adding 600 µl of ice-cold isopropanol and centrifuged at 13,000 rpm for 10 min at 4°C.
7. The pellet was dissolved in 200 µl of solution D and the DNA precipitated by adding 400 µl of absolute ethanol and centrifuged as in 6 above.
8. The DNA pellet was dried at 37°C and dissolved in 60 – 100 µl TE containing 20 µg/ml RNase.

2.7.6.2 Analysis of plasmid minipreparations for presence of DNA fragments

To determine the presence and size of DNA fragments in the plasmid DNA preparations, 4- μ l aliquots of plasmid DNA were digested with restriction enzymes used for cloning or with enzymes having recognition sites in the multiple cloning sites of the pGEM-T vector.

In general a digestion reaction comprised 4 μ l plasmid DNA and 0.5 μ l (5 units) of each of the respective restriction enzymes e.g. Sal I/Sac I for release of inserts from pGEM-T plasmid vector. After 1-1.5 h incubation at 37°C, 2 μ l sample loading buffer were added to 10 μ l of the total reaction mix and subsequently analyzed by electrophoresis in a 1% agarose gel containing ethidium bromide (section 2.6.6).

Plasmid minipreparations containing DNA fragments of the expected size were selected for further analysis.

Checking DNA inserts in recombinant plasmids by PCR

As an alternative to a plasmid minipreparation and subsequent restriction analysis, plasmid preparations were analysed for presence of DNA inserts by PCR. A standard PCR reaction was carried out as described in section 2.6.6 using the vector primers T7/T3 for pBluescript II SK- and T7/SP6 for pGEM-T flanking the multiple cloning sites of the respective vectors.

10 μ l of the PCR reactions were subsequently analysed for presence of amplicons by electrophoresis in 1% agarose gels.

2.8 Sequencing and sequence analysis

For sequencing DNA inserts of interest, plasmid DNA was extracted using the Qiagen mini kit following the manufacturers recommendations.

The services of a commercial company (Sequiseve, Vaterstetten, Germany) were used for DNA sequencing. Nucleotide sequences of the cloned PCR products were determined by cycle sequencing using a fluorescent dye dideoxy chain termination sequencing reaction kit and an applied Biosystems 373 A sequencer (PE – Applied Biosystems). Sequencing reactions were primed on both strands using either the

T7, T3 or Sp6 promoter sequences of the pBluescript II SK- or pGEM-T vectors or specifically designed sequencing primers.

Sequence alignment was done using the Clustal W (Thompson *et al.*, 1994) alignment routine. Clustal alignments were used to analyse critical regions in the sequences (intergenic regions, virus genes, coat protein) and, for inferring phylogenetic trees using the neighbour joining method developed by Saitou and Nei (1987). To determine the confidence values for the grouping within a tree, a bootstrap analysis (Felsenstein, 1985) was performed using 1000 resamplings of the data. These alignment routines are essentially part of the sequence analysis software DNAMAN for windows® 95/98, version 4.0 (Lynnon Biosoft).

2.9 Generation of full-length DNA-A and DNA-B genomic clones

2.9.1 Use of degenerate primers to amplify DNA-B fragments

Since a very limited sequence information was available for DNA-B components, degenerate primers c154, 5'-GGT AAT ATT ATA HCG GAT GG-3' and PBL1 v 2040 5'-GCC TCT GCA GCA RTG RTC KAT CTT CAT ACA-3' designed by Rojas *et al.* (1993) were used to amplify begomovirus DNA-B fragments.

Primer c154 was designed to anneal in the stem loop region of the genomic components, which is highly conserved among all begomoviruses. Primer BL 1 v 2040 was designed to anneal to the complementary sense strand within the 5' region of the BC1 gene. Its degenerate sequence reflected the amino acids Cys Met Lys Ile Asp His Cys, which are highly conserved in the BC1 genes.

PCR was carried out as described in section 2.6.6 with the annealing temperature set to 50°C.

PCR fragments obtained by this approach were ligated into pGEM-T vectors, used to transform *E. coli* and subsequently analysed by sequencing.

2.9.2 Amplification of full-length DNA-A and -B components using abutting primers

To generate complete sequences of DNA-A and DNA-B genomic components of respective cassava begomoviruses, sequences of DNA-A and DNA-B components retrieved from EMBL and GenBank, as well as sequences obtained from own experiments were analysed for presence of single restriction enzyme recognition sites.

Overlapping abutting primers for DNA-A were designed in the single restriction site for *Bam*HI just upstream of the AV2 ORF. For amplification of DNA-B full-length sequences, primers abutting at the *Nco*I site in BC1 as shown were used (Table 6 and 7).

Table 6. Primers used to amplify full-length DNA-A and DNA-B components of cassava begomoviruses

| Primer | Sequence(5'→3') | Strand | Target |
|-------------------|---------------------------------------|---------------|--------|
| ACMV A Bam up | taacgaagtgatgggatccactggtgaatgatgtt | virion | CP |
| ACMV A Bam lo | aacctcaagctggatcccacattgcgactagca | complementary | CP |
| UV/EA A Bam up | Taacgaagtcatgggatccattggtgaacgat | virion | CP |
| UV/EA A Bam lo | acctcaagctggatcccacatgttgacgcgctcta | complementary | CP |
| CLV NCO B up | tacgcccgggcatggtacgttatcatcaattgaa | virion | BC1 |
| CLV NCO B lo | cgagctcgagccatggcagctgctgtataaggtgaag | complementary | BC1 |

Table 7. Primer combinations used to amplify full-length DNA-A and DNA-B components.

| Virion sense primer | Complementary primer | Annealing temp.°C | Virus detected |
|---------------------|----------------------|----------------------|----------------|
| 1. ACMV A Bam up | ACMV A Bam lo | 61, 59, 57, 55, (53) | ACMV DNA-A |
| 2. UV/EA A Bam up | UV/EA A Bam lo | “ | EACMV DNA-A |
| 3. UV/EA A Bam up | UV/EA A Bam lo | ” | UgV DNA-A |
| 4. CLV B up | CLV B lo | ” | ACMV/UgV DNA-B |

One μ l of total plant DNA was subjected to a touch down PCR in a total reaction volume of 50 μ l, essentially as described in section 2.6.6, but using a mixture of a proof reading polymerase and a Taq polymerase (TaqPlus® Precision, Stratagene), and a buffer supplied with the enzyme by the manufacturer.

The annealing temperatures for the first 1 - 4 cycles were 61, 59, 57 and 55°C respectively. The lowest annealing temperature of 53°C was for the remaining 31 cycles. The annealing and extension time was 2 min for each incubation step . where a final extension period of 10 min at 72°C ended the PCR amplification. The predicted length of each component was about 2.8 kbp.

To determine the presence and size of PCR products, 10 μ l of the cycled PCR mix were analyzed by electrophoresis in a 1% agarose gel (section 2.6.2.2).

2.9.3 Cloning of full-length DNA-A genomic components

Full-length copies of genomic DNA-A components of different viruses were generated by PCR and cloned into the *Bam*HI site of pBluescript II SK- essentially as described in section 2.7.2.

A so-called head to tail partial dimer of the genomic DNA-A and respective DNA-B components was used for the infectivity studies of the cloned virus components.

For illustration of the cloning strategy used, cloning of the cassava begomovirus isolate Ca002 (UgV) from Siaya, Kenya, will be described.

The initial full-length DNA-A clone pBSK- Ca002A was digested at the unique restriction sites with *Bam*HI and *Hind*III resulting in three fragments, a 640 bp product, an approximately 2140 bp fragment and a vector fragment of approximately 3000 bp. The 640 bp fragment carrying the stem loop and origin of replication was gel purified as described in section 2.7.2 and then cloned in a *Bam*HI and *Hind*III digested pBSK- vector to result in pBSK-Ca002 0.3 H/B (Fig. 4).

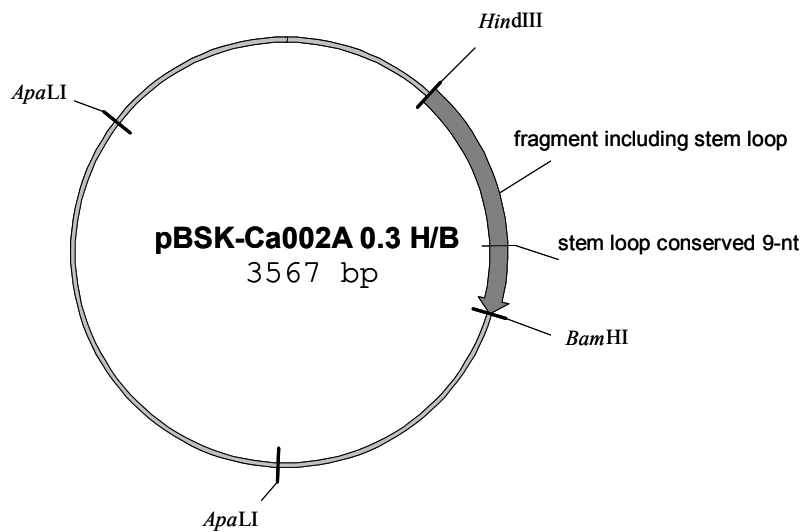

Figure 4. Subcloning of a DNA-A fragment containing the origin of replication into pBSK-.

A full-length DNA-A fragment of approx. 2800 bp was *Bam*HI excised from pBSK- and gel purified or, amplified from the plasmid by PCR using a proof reading polymerase, *Bam*HI digested and gel purified. The full-length DNA-A fragment was then cloned in the *Bam*HI linearized pBSK-Ca002 0.3 H/B to result in the partial dimeric pBSK-Ca002A 1.3 plasmid (Fig. 5).

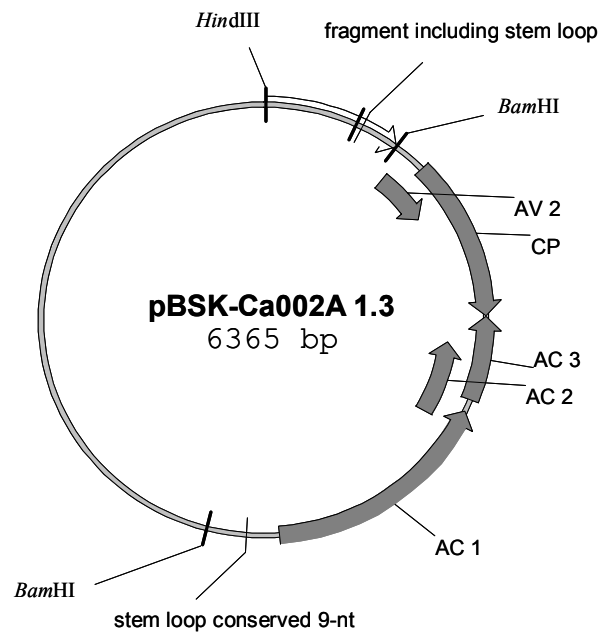

Figure 5. Construction of a partial head-to-tail dimer of Ca002 genomic component DNA-A.

The position of the partial repeat, as a head-to tail partial dimer was confirmed by a series of *Eco*RI and *Hind*III digestions resulting in characteristic fragments indicative of the position of the repeated genome sequences in the pBSK- vector.

2.9.4 Cloning full-length DNA-B genomic components

The DNA-B component (Ca002) was amplified by PCR, A-tailed (section 2.7.3) and subsequently cloned in the pGEM-T vector resulting in pGEM-T Ca002B (Fig. 6).

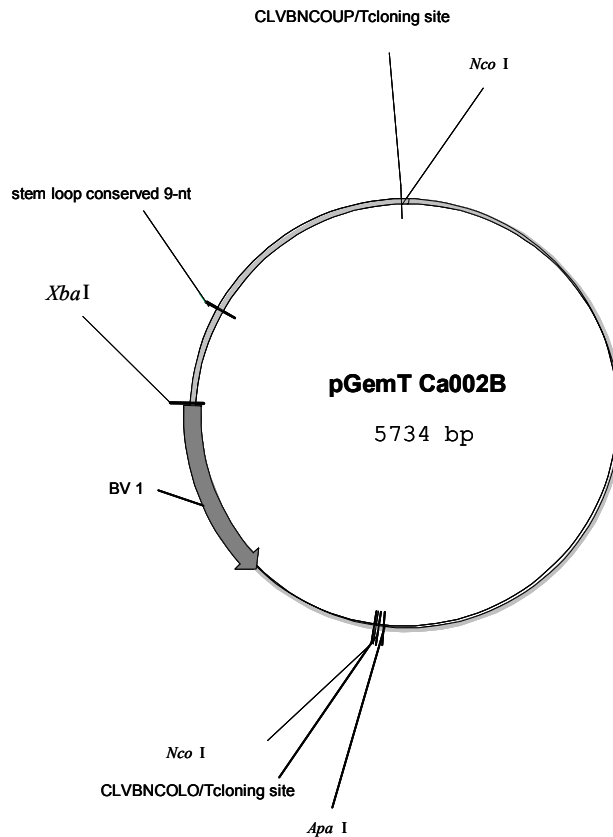

Figure 6. Cloning of a full-length NcoI DNA-B fragment of Ca002 into pGEM-T.

From pGEM-TCa002B an *ApaI/XbaI*, 0.3 full-length DNA-B fragment was released which comprised the stem loop structure of DNA-B. The *XbaI* site is unique in DNA-B while the *ApaI* site flanks the pGEM-T cloning site and was carried from the vector to comprise the *NcoI* DNA-B cloning site. The *ApaI/XbaI* fragment was subsequently cloned into an *ApaI/XbaI* digested pBSK- resulting in pBSK-Ca002B 0.3 A/X (Fig. 7).

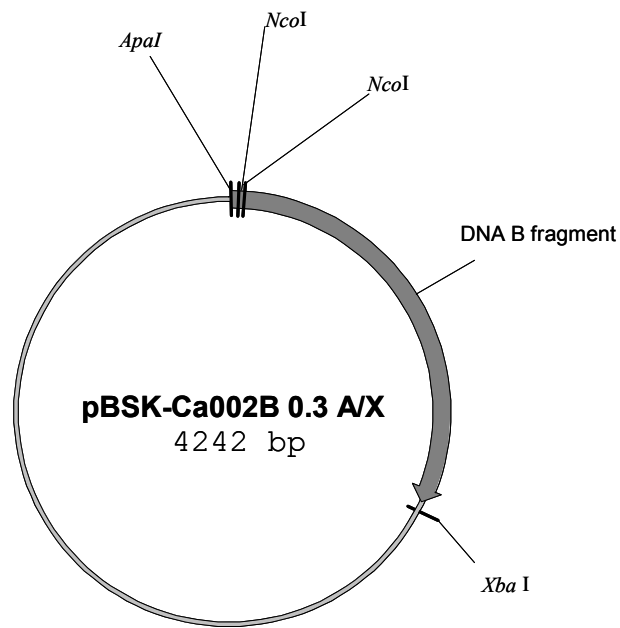

Figure 7. Subcloning of a 0.3 full-length DNA-B fragment into pBSK-.

This construct was *NcoI* digested and a full-length DNA-B fragment released from pGEM-T Ca002B was ligated into the introduced *NcoI* site of pBSK-Ca002B 0.3 A/X (Fig. 8).

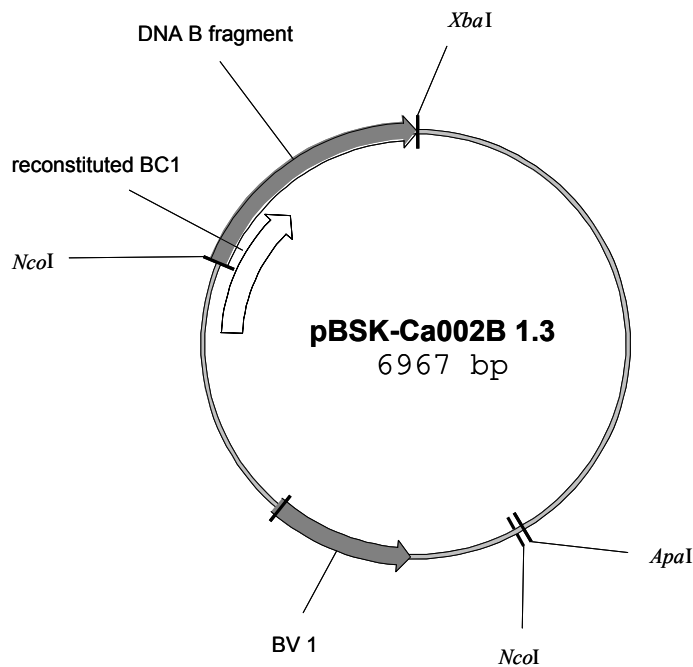

Figure 8. Construction of a 1.3 full-length partial head-to-tail dimer of a DNA-B genomic component.

The 1.3 partial dimeric DNA-B construct (pBSK-Ca002B 1.3) was digested with a series of restriction enzymes to confirm the head-to tail positioning.

2.9.5 Inoculation studies to infect *Nicotiana benthamiana* with cloned full-length virus genomes

All inoculation experiments were done in a security glasshouse under strict consideration of the biosafety guidelines governed by the German law (Gentechnik Gesetz, GenTG).

Full-length DNA-A and DNA-B components were excised from the cloning vector using *Bam*HI for DNA-A or *Nco*I for DNA-B mixed in equal amounts and inoculated onto *N. benthamiana* seedlings (1µg of each clone/plant) essentially as described by Stanely (1995).

Linearized DNA-A and DNA-B constructs using *Hind*III or *Xba*I, and undigested plasmid constructs carrying head-to-tail partial dimers were also used as inoculum in mechanical inoculation of cloned viral genomes to *N. benthamiana*.

Virus infections in *N. benthamiana* were monitored daily for symptom development. Presence of viral DNA and virions was verified 14-21 days post inoculation, using ELISA, PCR and ISEM.

2.10 Expression of EACMV and UgV coat protein genes

For cloning and expression of recombinant (EACMV-CP and UgV-CP) protein in *E. coli*, a pET 28a expression plasmid vector (Novagen, USA) was used.

Target genes are cloned in pET plasmids under control of strong Bacteriophage T7 transcription and translation signals, whereby expression is induced by provision of a source of T7 RNA polymerase in the host cells. When this is done, all the cell's resources are diverted to target gene expression and the desired product can comprise more than 50% of the total cell protein a few hours after induction.

2.10.1 Construction of the expression vector pET (cpEACMV and cpUgV)

The plasmids carrying the coat protein fragments of EACMV and UgV, cpEACMV and cpUgV were *Bam*HI/*Eco*RI digested as described in section 2.7.2 and separated by agarose gel electrophoresis. CP fragments were excised from the gel and purified using the QiaEx® II kit (section 2.7.2). The pET vector-28a was prepared accordingly to generate compatible ends. The two CP DNA fragments were subsequently ligated overnight at 16 °C into the pET expression vector 28a (Fig. 9) generating a translational fusion to the 5'- His Tag as follows:

Ligation mix:

6 µl insert DNA

3 µl pET vector

2 µl T₄ – DNA ligase buffer (10x)

1 µl T₄ – DNA ligase

8 µl H₂O

20 µl incubated at 16°C overnight

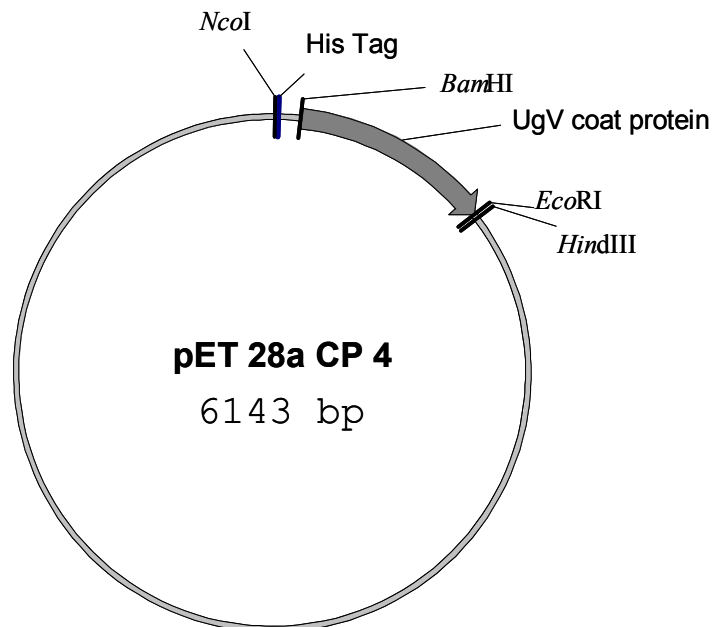

Figure 9. The expression vector pET 28a CP 4 construct containing the coat protein gene of EACMV.

Three μl of the ligation reaction were used in the transformation of JM109 *E. coli* cells as described in section 2.7.5. Positive transformants were checked by minipreparation (section 2.7.6.2) and subsequent restriction digestion. Some constructs were also analysed by sequencing to confirm their integrity (in-frame fusion) before being used to transform expression *E. coli* cells of strain BL 21 (DE3) pLysS.

2.10.2 Transformation of Epicurian coli® strain BL21 (DE3) pLysS

For protein expression, pET 28a CP plasmids were prepared and subsequently used to transform *E. coli* cells of strain BL21 (DE3) pLysS (Stratagene). These cells were grown under high selection pressure using the antibiotics kanamycin (30 mg/ml) and chloramphenicol (34 mg/ml).

2.10.3 Expression of fusion proteins

LB agar plates were prepared as described in section 2.7.1.1 but using kanamycin (30 mg/ml) and chloramphenicol (34 mg/ml) as selection antibiotics.

Solutions

Expression buffer:

50 mM Tris-HCl pH 8.0

1 mM EDTA

50 mM NaCl

IPTG 100 mM stock solution

1. For protein expression, a single BL21 colony was picked from a freshly streaked plate and used to inoculate 50 ml of LB medium in a 300-ml Erlenmeyer flask. The culture was incubated with shaking (125 rpm) at 37 °C until an A_{600} of 0.480 – 0.600 was reached.
2. A 2-ml cell suspension was aliquoted and was later used as un-induced expression control. Protein expression was induced by adding IPTG to a final concentration of 1 mM to the remaining culture.
3. The incubation was further continued for 4 h during which 2-ml samples were aliquoted at 2 and 4 h periods after induction. After the 4h incubation period, the bacterial cells were placed on ice for 5 min, harvested by centrifugation at 5000 rpm in a Sorvall centrifuge for 5 min and kept at -20 °C overnight and were used for batch protein purification (section 2.10.4).
4. To analyse protein expression levels and the fraction of soluble proteins in the protein fraction, samples taken at the time points in (2) and (3) above were centrifuged at 13,000 rpm for 1 min and resuspended in 500 μ l of expression buffer.
5. The bacterial cell suspension was sonicated on ice for 3 min at 50 watt and then centrifuged at 13,000 rpm for 10 min at 4°C.
6. A 30 μ l of the supernatants was aliquoted as the fraction of soluble cell proteins and the pellets were dissolved in 30 μ l water to comprise the fraction of insoluble matter. Both were mixed with an equal volume of SDS sample buffer (section 2.4.1) and either subjected immediately to electrophoresis or, kept at -20°C until use.

Samples were analyzed by SDS-PAGE as described in section 2.4 for the presence and solubility of the expressed coat proteins.

2.10.4 Purification of recombinant protein from expressed *E. coli* BL21 (DE3) pLysS cells

For His-Cp purification bacterial cells were purified using the Qiagen kit (QIAexpressionist™, Qiagen GmbH, Germany) basically following the manufacturer's protocol. Since essentially all protein was expressed in an insoluble form, a protein purification protocol was chosen which employs urea as a mild detergent, to purify protein under denaturing conditions.

Buffers:

Buffer B: 8 M Urea; 0.1 M NaH₂PO₄; 0.01 M Tris-Cl, pH 8.0

Buffer C: 8 M Urea; 0.1 M NaH₂PO₄; 0.01 M Tris-Cl, pH 6.3

Buffer D: 8 M Urea; 0.1 M NaH₂PO₄; 0.01 M Tris-Cl, pH 5.9

Buffer E: 8 M Urea; 0.1 M NaH₂PO₄; 0.01 M Tris-Cl, pH 4.5

1. The frozen pellet from the 50-ml IPTG induced culture (section 2.10.3) was thawed for 15 min on ice and resuspended in 5 ml of Buffer B.
2. Cells were lysed by agitation at room temperature for 1 hour or until the solution became translucent.
3. The lysate was centrifuged at 10,000 rpm for 30 min at room temperature to pellet the cellular debris.
4. One ml of a 50% Ni-NTA slurry was added to 4 ml lysate and mixed gently by shaking for 60 min at room temperature.
5. The lysate-resin mixture was carefully loaded onto a 10 ml column with the bottom cap still attached.
6. When the lysate-resin mixture had settled, the column cap was removed and the flow through collected for SDS-PAGE analysis.
7. The lysate-resin mixture was washed twice with 4 ml of Buffer C.

8. Elution of the recombinant protein from the Ni-NTA column was achieved by washing 4 times with 0.5 ml Buffer D, followed by 4 times elution with 0.5 ml Buffer E.
9. All collected fractions were analysed by SDS-PAGE.

2.10.5 Detection of coat protein by electro-blot immunoassay

To confirm whether the expressed protein was that of the viral CP expressed, an electro-blot immunoassay (Western blot) was conducted as described in section 2.4.2.

2.11 Characterization of filamentous viruses from cassava

2.11.1 Mechanical transmission and host range studies

A batch of *N. benthamiana* plants when inoculated with sap extracted from cassava leaves showing unusual CMD symptoms (clone Ca119 from Kwale, Kenya) developed symptoms, which were very unusual for a begomovirus infection.

Cassava brown streak virus (CBSV) was suspected as the putative pathogen and consequently a host range study was conducted for virus preliminary characterization. Mechanical inoculations were done as described in section 2.1.3 onto 5 plants of the following species that were at the 3-5 leaf stage: *Gomphrena globosa* L. (Amaranthaceae), *Chenopodium amaranticolor* Coste and Reynier, *C. quinoa* (Chenopodiaceae), *C. murale*, *Datura metel*, *D. stramonium* L., *Lycopersicon esculenta* (L) karst., *Nicotiana benthamiana*, *N. clevelandii* Gray, *N. debneyi* L., *N. glutinosa*, *N. glutinosa* 24a, *N. tabacum* cv. Samsun NN, *Physalis floridana* Rydb. and *Solanum demisum* L. (Solanaceae).

The plants were kept in the glasshouse for 2-3 weeks and monitored for symptom development.

2.11.2 Virus propagation and purification

Three to four weeks after inoculation with the putative CBSV symptomatic *N. benthamiana* plants were harvested and kept at -80°C until use.

1. For virus purification, 200 g of systemically infected leaves were homogenized (1:3, w/v) in 0.5 M phosphate buffer, pH 7.5, containing 0.5% Na_2SO_3 .
2. The homogenate was filtered through three layers of cheesecloth, 7% n-butanol was added and stirred for 1 h at 4°C . This was then clarified by centrifugation at 10,000 rpm for 10 min in a Sorvall GSA rotor at 4°C . The water phase was removed, adjusted to 6% polyethyleneglycol (PEG) MW 6000 and stirred for 1 h at 4°C .
3. The precipitate was collected after low speed centrifugation at 10,000 rpm for 10 min and the pellet dissolved in 0.02 M phosphate buffer, pH 8.2, containing 0.1% mercaptoethanol and stirred overnight at 4°C .
4. After a centrifugation step at 10,000 rpm for 10 min at 4°C , the supernatant was decanted and 0.4 g CsCl added to each ml of solution. CsCl was thoroughly dissolved and a buoyant density gradient centrifugation was done at 45,000 rpm in a Beckman 70.1Ti rotor for 20 h.
5. Light breaking, opalescent bands were removed from the gradient using a syringe, diluted in 0.02 M phosphate buffer, pH 8.2, containing 0.1% mercaptoethanol, and centrifuged at 55,000 rpm in a Beckman 70 Ti rotor for 2h to remove the CsCl .
6. The final pellet was resuspended in 0.02 M Tris buffer, pH 8.2.

The resulting partially purified virus preparations were analysed by electron microscopy (section 2.5) and SDS-PAGE (section 2.4.1).

3 RESULTS

3.1 Characterization of begomoviruses infecting Cassava in Africa

3.1.1 Symptoms of ACMV, EACMV, and UgV in Cassava and in *Nicotiana benthamiana*



Figure 10. Cassava plants with typical symptoms of a) UgV, b) EACMV, c) ACMV + EACMV and d) ACMV infections.

The symptoms induced by ACMV, EACMV and UgV in cassava and in *N. benthamiana* under experimental conditions are shown in Fig. 10 and 11. In cassava, symptoms ranged from barely perceptible mosaic to bright mosaic with mild to severe leaf distortions, extreme reduction of the leaf blades and complete stunting of the plant. Observations made in the field and in the glasshouse indicate that all the three viruses induce similar symptom patterns on the foliage of infected cassava. Symptom severity of CMD in cassava plants which were maintained in the glasshouse over a 2-year period and which were singly or doubly infected with ACMV, EACMV and UgV showed the following: 1) plants infected with ACMV showed mild to severe symptoms and often recovered from the disease, 2) plants infected with either EACMV or UgV exhibited moderate to severe symptoms on a continuous basis and rarely recovered from the disease and 3) plants doubly infected with both ACMV and UgV developed symptoms similar to those infected with UgV alone. Two cassava plants obtained from Kisangani in the DRC in 1998 when doubly infected with both ACMV and UgV and whose virus infection status was being checked after every 6 months, 'lost' ACMV in June 2000. Subsequent checks have since failed to trace ACMV in the plants and CMD symptoms could hardly be seen. Some varieties obtained from the field when infected with ACMV and showing CMD symptoms recovered from the disease completely after having been planted in the glasshouse. It is worth noting that some mild isolates of ACMV and EACMV turn severe and vice versa depending on environmental and nutritional conditions of the plant. However, this phenomenon rarely occurred in samples infected with UgV isolates. In addition, most field samples from the DRC, Kenya and Uganda doubly infected with either ACMV and UgV or ACMV and EACMV did not develop severe symptoms. Based on these observations it was concluded that cassava begomoviruses induce similar, non-distinctive symptoms in host cassava plants.

In *N. benthamiana*, symptoms of diffuse chlorotic lesions followed by systemic curling, leaf deformation and yellow blotching were observed. Plants infected with EACMV and UgV often developed similar and mild symptoms beginning with systemic curling and crinkling of leaves followed by stunting but failed to develop chlorotic lesions and/ or yellow blotching. In contrast, ACMV and ICMV always induced severe symptoms in *N. benthamiana* plants and the symptoms of

ACMV-KE and ACMV-NG, though similar in severity, were different in appearance in that ACMV-KE induced early yellow blotching symptoms whereas ACMV-NG induced late and milder yellow blotches in host plants



Figure 11. Symptoms of CMD in *N. benthamiana* plants after biolistic (a and b) and sap (c and d) inoculation. Plants infected with: a) UgV, b) ACMV + UgV, c) ACMV-KE and d) ACMV-NG.

3.1.2 Mechanical transmission of begomoviruses infecting cassava to *Nicotiana benthamiana*

Twenty cassava begomovirus isolates (Table 8) were tested for their transmissibility to *N. benthamiana*. This was done either by rub inoculation of sap extracts from leaves (under 'I', Table 8), or by biolistic bombardment of total DNA extracted from infected plants (under 'II', Table 8).

Infections were recorded according to symptoms observed 9 to 21 days post inoculation. Virus detection was done by TAS-ELISA using ACMV antisera for coating and MAbs 4F10, 1H2 and 1C1 for detection, and by PCR.

Table 8 summarizes the results of the virus transmission studies. Both methods of virus transmission resulted in good virus infections with efficient virus delivery into the host plants. However, while isolates of ACMV, ICMV and EACMV were readily transmissible, UgV isolates from Western Kenya and Uganda were not effectively transmitted to *N. benthamiana*. Ca002, a UgV sample from Kenya was not transmitted by either method and only 1 of 20 *N. benthamiana* plants became infected by biolistic inoculation with Ca016 from Uganda. However, UgV samples (Nos. 171, 178 and 185) obtained from the DRC could be transmitted more easily to *N. benthamiana* by both methods.

When sap extracted from plants doubly infected with either ACMV and UgV (No. 171) or, with ACMV and EACMV (No. 35) was inoculated onto *N. benthamiana*, only ACMV was successfully transmitted.

EACMV (No. 112) was transmitted more efficiently by biolistic method than by sap inoculation, whereas EACMV samples (Nos. 119, 123, 124, and 125) from Kwale, Kenya, were transmitted moderately to *N. benthamiana* by biolistic inoculation and could not be transmitted by sap inoculation. EACMV was not detected in symptomatic plants by ELISA and by PCR. A virus in sample Ca126 obtained from a cassava plant infected with EACMV, was not transmitted by either approach, however, severe viral symptoms were induced by mechanical inoculation of *N. benthamiana*. However ELISA and PCR failed to detect EACMV in symptomatic *N. benthamiana* plants inoculated with sap from Ca126.

When additional herbaceous test plants were inoculated with sap extracts from Ca126, symptoms different from typical begomovirus symptoms were obtained. In *N. benthamiana*, vein yellowing, mottling and vein banding and systemic chlorosis

was visible approximately 5-8 days after inoculation (Fig. 11a). Cassava begomovirus infections were not detected in these plants, however, upon electron microscopical examination, filamentous virus-like particles were demonstrated. Further analysis showed that in addition to samples Ca126, samples 119, 123, 124 and 125, all obtained from the same location contained similar filamentous viruses, but in a mixed infection with EACMV. Attempts to characterize the putative viruses are described separately in section 3.7.

Cassava begomovirus isolates were transmitted more easily to cassava by grafting than by biolistic inoculation. The isolates induced bright mosaic symptoms on cassava 2-3 weeks after grafting with infected scions. After a few months, most of the cassava varieties started to produce flushes of symptomatic leaves interspersed with symptomless ones. The introduction of mixed infections in a cassava variety from Madagascar infected with ACMV and grafted with UgV infected scions (Fig.10c) resulted in very severe symptoms while similar mixed infections of ACMV/UgV with samples from Uganda, the DRC and Kenya, did not result in more pronounced disease symptoms. A virus-free cassava variety from Nigeria (Isumi) when graft inoculated with both ACMV and EACMV developed very severe symptoms, the plant became completely stunted and the stem remained soft and brittle.

Symptom development of virus infections in cassava induced by mechanical inoculation, biolistics or by grafting was highly dependent on the cassava variety used as the virus host. A general statement on the symptom status of a cassava plant infected with one or more begomoviruses could not reliably be made.

Table 8. Infectivity of 20 cassava begomovirus isolates to *N.benthamiana* by sap (I) and by biolistic (II) inoculation.

| Sample number | Sample origin | Virus detected in cassava | Infected/inoculated | | Virus detected in <i>N. benthamiana</i> |
|---------------|-----------------|---------------------------|---------------------|------------------|---|
| | | | I | II | |
| 2 | Siaya, Kenya | UgV | 0/20 | 0/6 | - |
| 5 | Nyenga, Uganda | ACMV/UgV | ^a 15/20 | 5/6 | ACMV |
| 7 | Kakamega, Kenya | ACMV/EACMV | 12/20 | 5/6 | ACMV |
| 16 | Ngiya, Uganda | UgV | 0/20 | 1/5 | UgV |
| 23 | Madagascar | ACMV | 15/20 | 4/5 | ACMV |
| 31 | Isumi, Nigeria | ACMV | 18/20 | 6/6 | ACMV |
| 35 | Guinea | ACMV/EACMV | ^a 18/20 | 3/6 | ACMV |
| 36 | India | ICMV | 16/20 | 5/6 | ICMV |
| 65 | Busia, Kenya | ACMV | 13/20 | 5/6 | ACMV |
| 77 | Ghana | ACMV | 17/19 | 4/6 | ACMV |
| 84 | Kinshasa, DRC | ACMV | 12/20 | 3/6 | ACMV |
| 112 | Kilifi, Kenya | EACMV | 3/20 | 4/6 | EACMV |
| 119 | Kwale, Kenya | EACMV | ^b 20/20 | ^c 2/6 | EACMV |
| 123 | Kwale, Kenya | EACMV | ^b 18/20 | ^c 3/6 | EACMV |
| 124 | Kwale, Kenya | EACMV | ^b 20/20 | ^c 2/5 | EACMV |
| 125 | Kwale, Kenya | EACMV | ^b 16/20 | ^c 2/6 | EACMV |
| 126 | Kwale, Kenya | EACMV | ^b 17/20 | 0/6 | - |
| 171 | Ikelanoke, DRC | ACMV/UgV | ^a 13/20 | 4/6 | ACMV |
| 178 | Yafela, DRC | UgV | 10/20 | 4/6 | UgV |
| 185 | Kisangani, DRC | Ugv | 6/20 | 3/6 | UgV |

^a Plants infected only with ACMV.

^bPlants infected with filamentous virus. EACMV could not be detected in these test plants.

^cOnly EACMV was detected in these test plants.

3.1.3 Particle morphology

Upon examination of crude sap extracts from infected *N. benthamiana* and cassava under EM, only the bi-segmented, geminate, icosahedral particles typical of cassava mosaic begomovirus infections were observed in both field and glasshouse samples from virus-infected plants (Fig. 12). These particles were observed only in ISEM, whereby crude sap of virus-infected plants was incubated overnight on ACMV polyclonal antiserum coated grids.

The particles were morphological indistinguishable (Fig. 12).

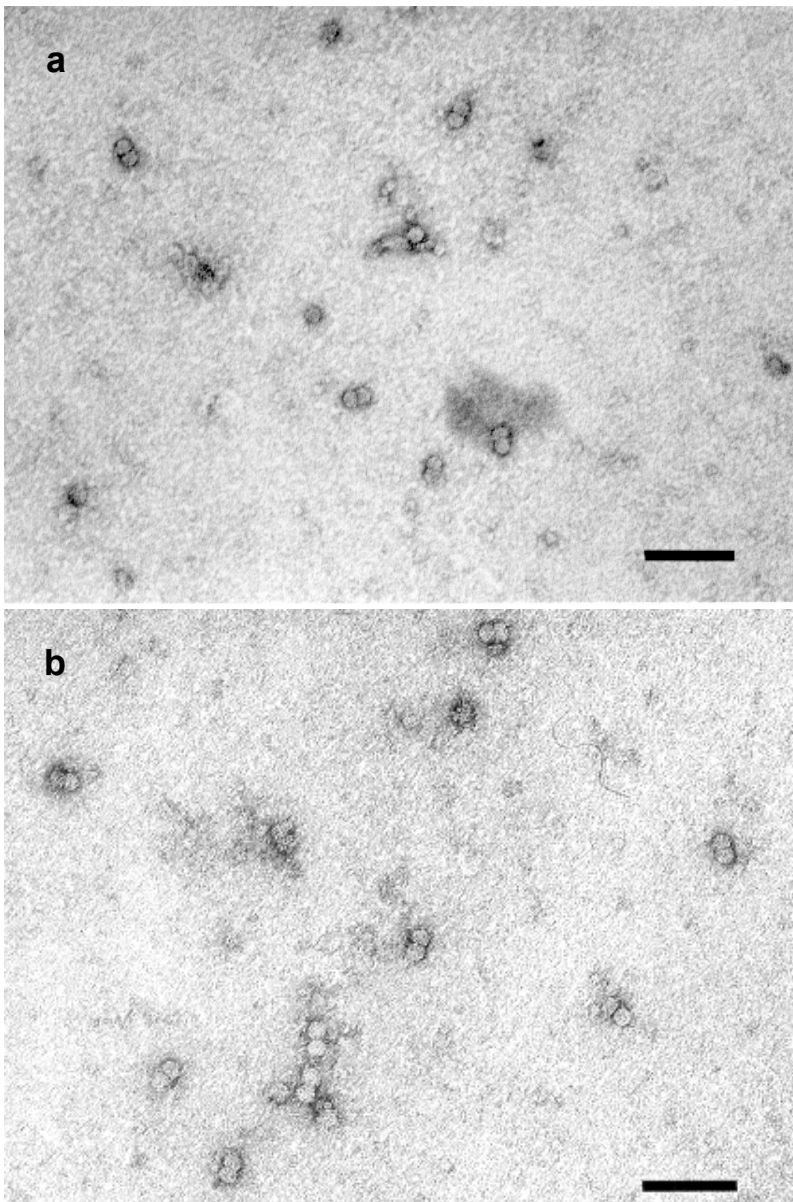

Figure 12. Electron micrograph showing a negatively stained preparation (1% UAc) of begomovirus particles from crude sap of a) ACMV-, and b) EACMV-infected cassava, and decorated with ACMV-IgG diluted at 1:1000 (v/v). Bar represents 100 nm.

3.1.4 Analysis of viral capsid proteins

The coat proteins of cassava begomoviruses in protein extracts of infected *N. benthamiana* plants and of cassava were analysed by electrophoresis followed by electro-blot immunoassay, EBIA. Despite the severe symptoms in these plants, a peptide band representing the size of the putative coat protein could not be detected in Coomassie stained gels (Fig.13, left), hence the need for EBIA (Fig. 13, right). RuBisCo, a 54 kDa protein (Fig.13, left open arrow), which comprises almost 80% of the total protein of the green plant cell, was the most predominant band in total leaf protein extracts. It was also unspecifically stained during substrate incubation in EBIA (Fig.13, left, open arrow).

The detection of begomovirus coat protein peptides by EBIA was possible with protein extracts of *N. benthamiana* and with cassava. In extracts of infected plants (lane 4-9), a coat protein peptide of approximately 30-31 kDa reacting with the polyclonal ACMV IgG, was verified after substrate incubation (Fig. 13, black arrow). Coat protein sizes of all viruses assayed were similar and minor differences in size were attributed to variable conditions of western transfer (Fig. 13, left). Although in *N. benthamiana*, virus concentration was generally higher (lane 9), high virus concentrations were especially found in young shoots of cassava plants suffering from mixed infections with UgV and ACMV (lane 4).

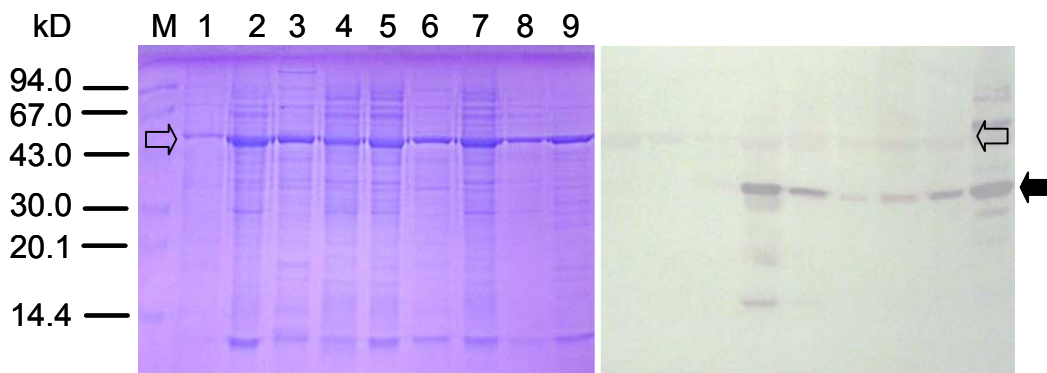

Figure 13. SDS polyacrylamide electrophoresis (left) and electroblot immunoassay (right) for detection of begomoviruses in leaf extracts of cassava plants infected with: 4) ACMV and UgV, 5) UgV, 6) ICMV, 7) EACMV, 8) ACMV, 9) PV-0095, ACMV-KE. Lane 1, non-infected cassava control; lane 2, non-infected *N. benthamiana*; lane 3, cassava infected with unknown virus and M = Low molecular weight marker. M_r in kDa, is indicated on the left.

3.2 Serological assays, nucleic acid hybridization and PCR

3.2.1 Production and characterization of monoclonal antibodies, MAbs

A panel of hybridoma cell lines raised against a *Tomato yellow leaf curl virus* isolate from Yemen was screened against begomoviruses infecting cassava. This was merely, to disclose the capacity of existing MAbs raised against one begomovirus and to take into account the extremely tight amino acid conservation among the coat proteins of many species of this genus.

To complement the library of MAbs and to obtain antibodies with specific reaction to EACMV, attempts were also made to raise MAbs against this particular virus species.

3.2.1.1 Expression of EACMV coat protein in bacteria for antigen preparation

Recombinant EACMV coat protein was expressed and purified from *E. coli*. After expression for 4 h at 37°C, a definite band representing expressed coat protein was not visible and extracts prepared from induced and un-induced controls appeared similar in SDS-PAGE. However, when expressed protein was purified by binding on Ni-NTA columns (section 2.10.4), a band slightly bigger (approximately 37 kDa) than the expected size of the CP was enriched in fraction 1 and 2 of the elution buffer D (Fig. 14 a).

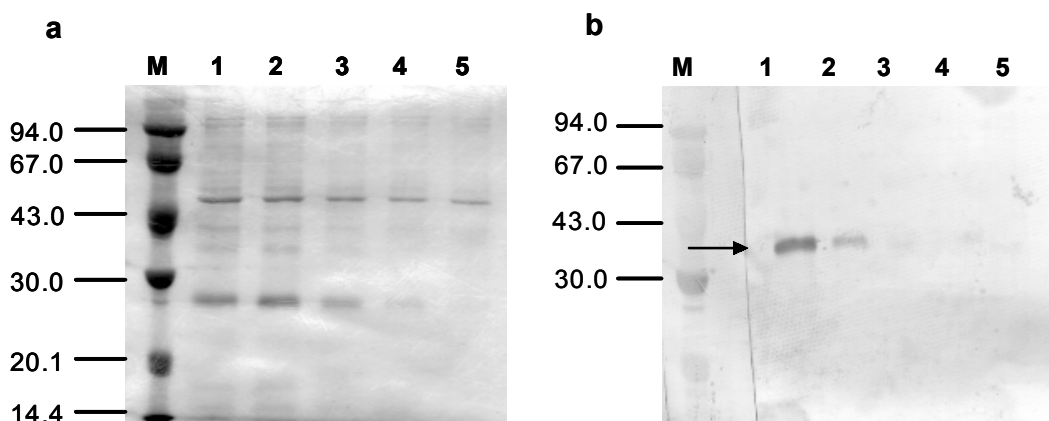

Figure 14. a) SDS-PAGE of expressed EACMV coat protein; b) Western blot signals of the expressed EACMV coat protein using ACMV polyclonal antisera. Lane 1-3, Ni-NTA column eluates in elution buffer D; lanes 4 and 5, column fractions in elution buffer E.

This protein fraction eluted was verified as the expressed EACMV coat protein by Western blot analysis and immunoreaction with ACMV IgG (Fig. 14 b). There was still a fair amount of bacterial protein evident in SDS gels and hence the CP band was excised from the polyacrylamide gel and solubilized in PBS for immunization of mice.

Three fusions were carried out with spleenocytes from mice immunized with expressed coat protein excised from SDS polyacrylamide gels. From these fusions 4 cell lines specifically reacted with begomovirus infected plant material, however, after the subcloning regime, only 1 hybridoma cell line remained positive and virus specific. Furthermore, during the evaluation process using different viral antigens, it became evident, that this clone 6E9 selected only reacted with ACMV-NG and ACMV-KE (Table 9).

3.2.1.2 Titre determination of monoclonal antibodies in hybridoma cell culture supernatants

The activity of the monoclonal antibodies in the culture supernatants was determined by TAS-ELISA. MAb concentrations in the cell cultures were reflected by the dilution of the antibodies used for TAS-ELISA ranging between 10^{-1} - 10^{-2} and resulting in clear ELISA positive reactions after a substrate incubation at 37°C for 1-3 h. These hybridoma culture supernatant dilutions were used for all further analysis by TAS-ELISA.

3.2.1.3 Evaluation of monoclonal antibodies for detection and differentiation of begomoviruses

MAbs from TYLCV hybridoma cell lines and from EACMV hybridomas were tested against 4 African cassava begomovirus isolates and against ICMV, in a TAS-ELISA format (Table 10). For reference purposes, two MAbs, raised against ACMV SCR 23 and SCR 33 were included in the analysis.

In TAS-ELISA using the ACMV polyclonal antibody for coating 16 of 23 MAbs screened were selected with specific and differential reaction against the begomoviruses from Africa and India (Table 9).

Table 9. Reactions of MAbs raised against TYLCV and EACMV in TAS-ELISA with cassava mosaic begomoviruses from Africa and ICMV from India.

| MAb | ACMV-KE | ACMV-NG | EACMV | UgV | ICMV |
|----------------|----------|----------|----------|----------|----------|
| 6A6 | Strong | Moderate | None | Strong | None |
| 4F10 | Strong | Moderate | None | Strong | None |
| 1B3 | Moderate | Moderate | None | Moderate | None |
| 5B5 | Strong | Moderate | None | Moderate | None |
| 2F1 | Strong | Moderate | None | Moderate | None |
| SCR 33 | Moderate | Moderate | None | Weak | None |
| 1C1 | Strong | Moderate | Moderate | Strong | None |
| 4D12 | Strong | Moderate | Moderate | Strong | None |
| 4G8 | Strong | Moderate | Moderate | Moderate | None |
| 4E6 | Weak | Weak | Weak | Weak | None |
| SCR 23 | Weak | Weak | Weak | Weak | None |
| 4F11 | None | Strong | Strong | Strong | None |
| 1H2 | None | Strong | Moderate | Strong | None |
| 5D8 | None | Strong | Strong | Strong | None |
| 4G7 | None | None | None | None | Moderate |
| (EACMV) 6E9 | Weak | Weak | None | None | None |

| | |
|--|--|
| | > 2.500 (Strong reaction) |
| | 1.500 – 2.499 (Moderately strong reaction) |
| | 0.500 – 1.499 (Weak reaction) |
| | < 0.500 (No reaction or insignificant reaction, Healthy) |

ICMV, which is a well separated virus species was detected specifically by MAb 4G7 which did not react with any of the African cassava begomoviruses tested.

All MAbs screened reacted with more than one isolate, which reflects the very close homology and sequence conservation of the viral coat proteins. ACMV-NG and UgV isolates had a similar MAb reaction profile but 3 MAbs (4F11, 1H2, 5D8) failed

to react with ACMV-KE despite the fact that they had strong reactions with the other two begomoviruses.

5 TYLCV MAbs (6A6, 4F10, 1B3, 5B5, 2F1) and SCR 33 failed to react with EACMV, whereas all MAbs, with the exception of 6E9, reacted with UgV.

3.2.1.4 Determination of antibody classes and subclasses

As shown in Table 10, most monoclonal antibodies, except 4F11 and 1H2, reacted with only one Ig-type specific antibody. This provided evidence for monoclonality of the MAbs or, lack of it. 9 MAb lines tested were of the type IgG1, IgG2b or IgM. Lines 4F11 and 1H2 reacted with two antisera specific for IgG1 and for IgG2b implying that the two MAbs were not monoclonals. Nevertheless, they were frequently used for detection in TAS-ELISA.

3.2.1.5 Particle decoration and ISEM

The results of ISEM are summarised in Table 10. MAbs 6E9, 6A6, 1C1,4D12 and 6E9 failed to trap virus particles in ISEM. However, 4F10, 1H2, 4F11 and 4G7 were able to trap virus particles. In ISEM + decoration, medium reactions in which particles were clearly but not strongly decorated were observed with MAbs 1H2, 4F10 and 4F11.

Table 10. Properties of some monoclonal antibodies that were used in routine analysis

| Antigen | MAb | Titre | Isotype | ISEM | ISEM + Decoration |
|---------|------|------------------|-----------|------|-------------------|
| TYLCV | 6A6 | 10 ⁻² | IgG1 | - | - |
| | 4F10 | 10 ⁻² | IgG2b | ++ | ++ |
| | 1C1 | 10 ⁻² | IgG2b | - | - |
| | 4D12 | 10 ⁻² | IgG2b | - | - |
| | 4F11 | 10 ⁻² | IgG1 + 2b | ++ | ++ |
| | 1H2 | 10 ⁻² | IgG1 + 2b | + | ++ |
| | 4G7 | 10 ⁻¹ | IgG1 | + | - |
| EACMV | 6E9 | 10 ⁻¹ | IgM | - | - |

++ medium reaction, + weak reaction and - no reaction.

3.2.2 Detection of begomoviruses by ELISA

From the MAb reactions summarized in Table 9, it became evident that a positive detection of a respective begomovirus type in infected plants was not possible. Hence, a serological approach for differentiating begomoviruses required the use of a panel of differentially reacting MAbs for specific determination of a virus type by TAS-ELISA (Table 11).

Table 11. Differential reactions of four monoclonal antibodies in TAS-ELISA for definition of an African cassava mosaic begomovirus type in an infected plant

| MAb 1C1 | MAb 6E9 | MAb 4F10 | MAb 1H2 | MAb 4G7 | Virus defined |
|---------|---------|----------|---------|---------|----------------|
| + | + | + | + | - | ACMV-NG |
| + | + | + | - | - | ACMV-KE |
| + | - | + | + | - | UgV |
| + | - | - | + | - | EACMV |
| - | - | - | - | + | ICMV |

One major drawback of this serological approach for virus definition was that mixed virus infections, consisting of ACMV and UgV or, ACMV and EACMV could not be satisfactorily resolved.

3.2.3 Detection of begomoviruses by tissue blot immuno assay, TBIA

For a rapid serological analysis of begomovirus infections in cassava plants, a tissue blotting protocol was developed. Various MAbs were used in TBIA and the reaction of MAb 4F10 with a tissue blot of a UgV infected cassava and a UgV infected *N. benthamiana* is exemplified in Fig. 15. Positive reactions seen as red pigments were clearly observed in infected tissues and were absent in tissue prints of healthy ones (Fig. 15 a-c). Detection of begomovirus antigen in cassava (Fig. 15b) using TBIA was rather weak compared to signals obtained with infected *N. benthamiana* plants (Fig. 15a). Apart from the apparently higher concentration of virus in *N. benthamiana* compared to cassava, TBIA also revealed different tissue tropisms of begomoviruses in different plant species.

While viral antigen was only detected in phloem areas of infected cassava, antigen was more evenly distributed in *N. benthamiana* and detected in phloem and parenchyma tissues of transversely sectioned stem, petiole, leaves and sprouts (Fig.15a).

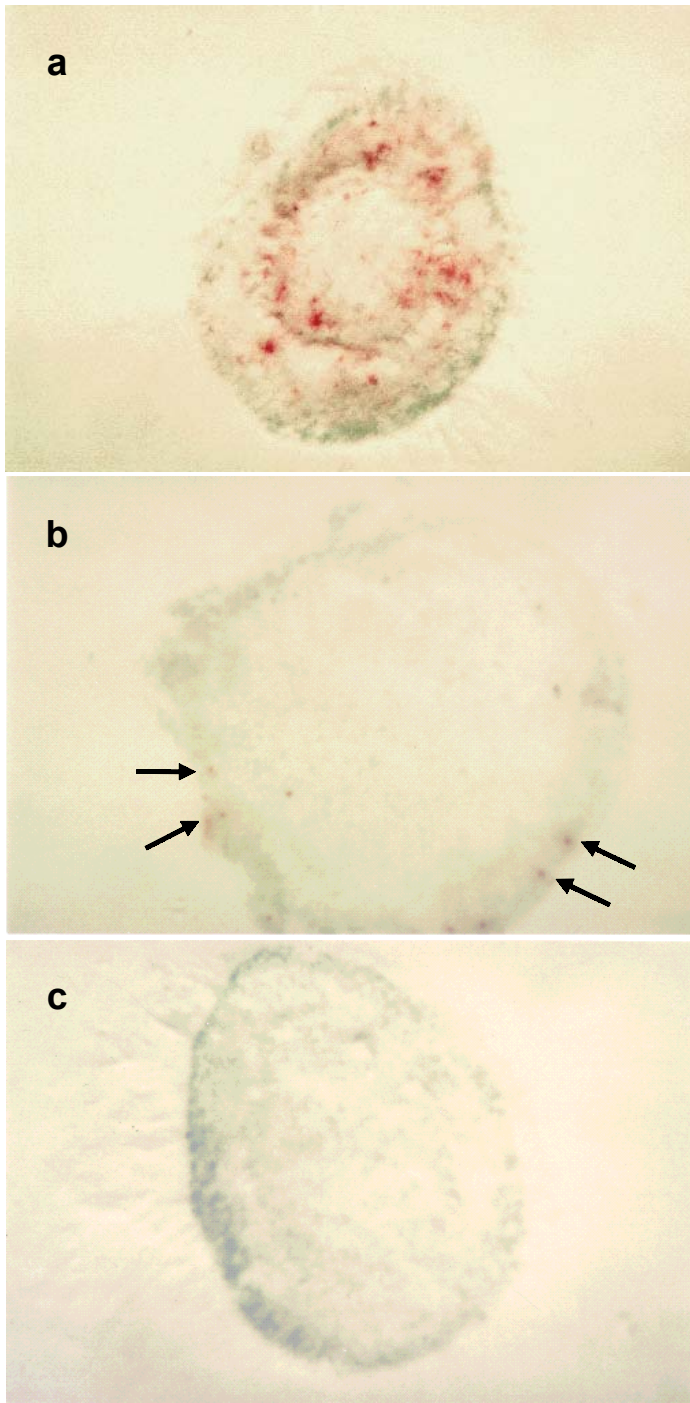

Figure 15. Detection of UgV by tissue blot immunoassay, TBIA, in shoot sections of a) *N. benthamiana* and b) cassava using MAb 4F10 and the substrate Fast red. c) control reaction of non-infected *N. benthamiana*. Positive reactions with virus antigen appear as red spots (a and b) indicated by arrows.

3.2.4 Detection of begomoviruses in cassava by nucleic acid hybridization

Using full-length pBSK011 (ACMV) DNA-A probes radiolabelled with α 32 P dCTP, it was not possible to detect virus DNA in tissue prints of either cassava or *N. benthamiana*.

When cassava leaf extracts were prepared and spotted onto nylon membranes, viral DNA was detected by nucleic acid hybridization (Fig.16a and b). Using a full-length pBSK002 (UgV) DNA-A probe, only sequences related to the Uganda variant virus were detected and under high stringency washing conditions only UgV (Fig 16 b, column 4) and EACMV (Fig. 16b, column 7) sequences were detected in hybridization analysis, while ACMV sequences remained undetected (Fig. 16b, column 2,3). The weak hybridization signal obtained with EACMV sample Ca112 reflected the low concentration of EACMV in infected cassava rather than limited sequence identity between EACMV DNA-A and that of UgV.

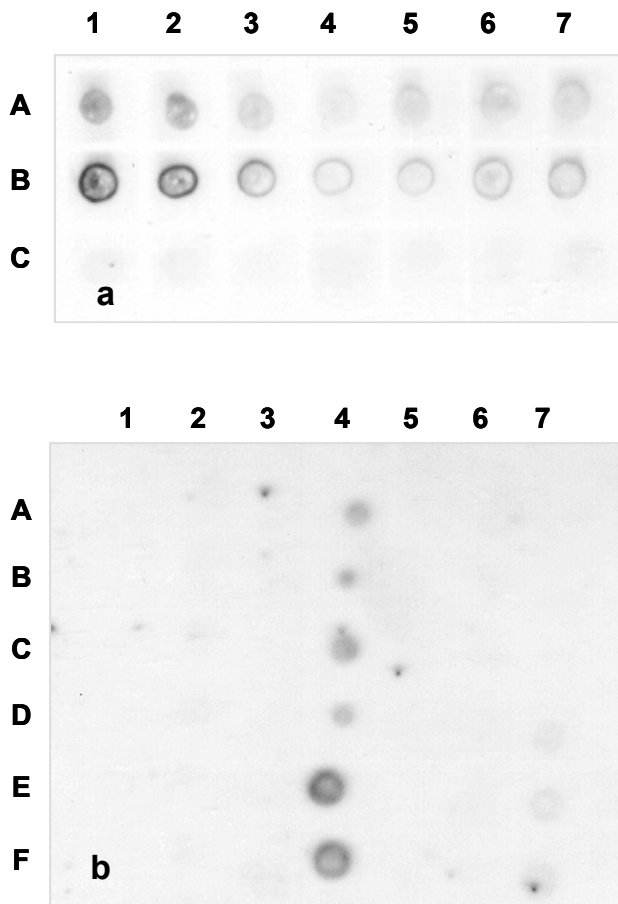

Figure 16. Detection of cassava begomoviruses by dot blot hybridization using α 32 P dCTP radiolabelled a) ACMV DNA-A specific probe (pBSK011).

Cassava samples infected with, A= ACMV-KE; B= ACMV-Togo and C= non-infected control. The number represent age of shoot / leaf used with 1= very young and 7= old.

b)UgV DNA-A specific probe (pBSK002). Cassava samples infected with 1= ACMV-NG; 2= ACMV-KE; 3= non infected *N.benthamiana*; 4= UgV; 5= non-infected cassava; 6= ACMV-Ghana and 7= EACMV-KE. Letters represent age of shoot / leaf used with A= old shoot and F= very young shoot.

3.2.5 Detection and differentiation of cassava begomoviruses by PCR

PCR was most versatile for virus detection in cassava since the amplification of viral sequences during PCR made a reliable detection of cassava begomoviruses largely independent from initial virus DNA concentrations.

A limited number of DNA-A sequences of cassava begomoviruses (ACMV-NG, ACMV-KE, EACMV, and UgV) was available that was essential in designing primers for detection particularly for discrimination between and among the viruses. Fig. 17 exemplifies the results of a discriminative PCR.

For detection of EACMV and UgV a primer combination developed by Zhou *et al.* (1997) was used, however, this primer combination could not differentiate between the two viruses (data not shown) either singly or in mixed infection. Hence a primer combination EACMVT588U20 // UV ECO CP was designed and could distinguish EACMV from other viruses even in samples where both viruses were present (Fig. 17b). The primer combination UV AL1 /F1 // CAGUCO1129L20 amplified only DNA-A fragments related to UgV (Fig.17c) whereas the primer combination developed by Zhou *et al.* (1997), ACMV AL1/F // ACMV ARO/R, only amplified ACMV sequences (Fig 17a).

The general begomovirus primer combination (Table 3, Begomo 146 // 672) with primers designed to anneal in highly conserved regions of begomoviruses covering the first 550 nt of DNA-A and spanning into the coat protein core region, amplified DNA-A fragments of isolates of the following viruses: ACMV, EACMV and UgV (Fig. 9D), as well as ICMV, TYLCV and Lima bean golden mosaic virus (data not shown).

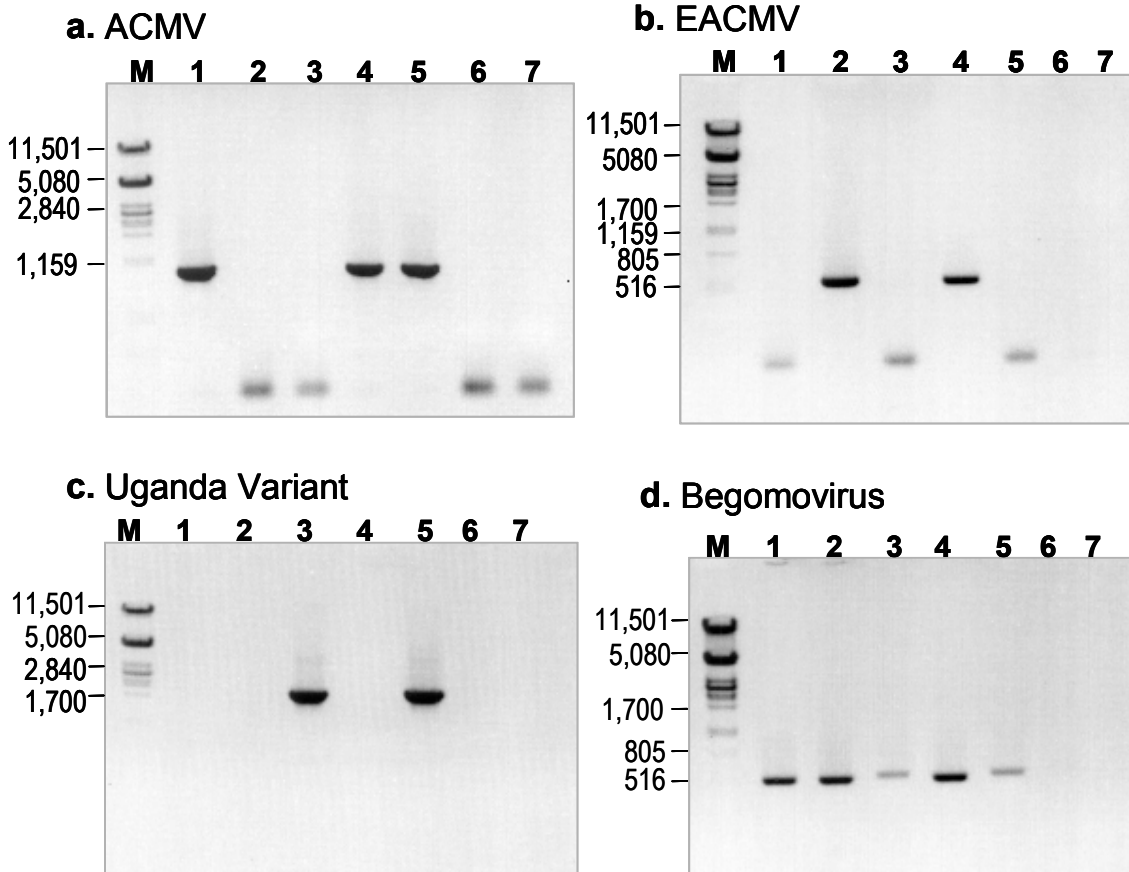

Figure 17. Gel electrophoresis of PCR amplified DNA fragments with primers specific for A) ACMV, B) EACMV and C) UgV. D) genus-specific primer amplifying many begomoviruses.

Lane M-Marker, lanes 1-7 represent cassava samples infected with: 1-ACMV, 2-EACMV, 3-UgV, 4-ACMV+EACMV, 5-ACMV+UgV, 6-non-infected cassava plant and 7-water control.

3.3 Survey of CMD in Kenya

3.3.1 CMD symptoms in cassava fields

As described in section 1.2.1, various types of CMD symptoms were observed in cassava plants in the field (Fig. 18). Symptoms of virus infected cassava plants maintained in the glasshouse (Fig. 10) resembled symptom types observed in the field.

Cassava plants showing only mild symptoms on leaves developed normally and frequently, symptomatic leaves were interspersed or alternated with flushes of

leaves with fewer or no symptoms. Cassava plants with severe mosaic symptoms displayed distinct chlorosis, reduction of leaf size along with leaf distortion. Despite severe symptoms on the leaves, medium-sized tubers could still be harvested from plants with ACMV or EACMV infection (Fig. 18 bottom right).



Figure 18. Typical severe CMD symptoms in cassava in the field (left) with leaves showing mosaic and leaf distortion (upper right). Medium sized tubers from infected plants (bottom right) could still be obtained.

3.3.2 Locations and samples collected

In total, 230 cassava leaf samples and 61 hardwood stem cuttings from farmers fields throughout cassava growing regions in Kenya were collected and analysed (Fig.19 and in Table 12, section 3.3.5).

3.3.3 Cropping systems, disease symptoms, and other pests

Coast province: Most popular cassava varieties grown in this province were Kibandameno, Gusho, Number 4 and Kibesho. In Kilifi district, cassava was grown mostly under fruit plants like mangoes and bananas and in Kwale, it was grown under cashewnuts and pineapples. In this district few farmers had intercropped cassava with maize and many were expanding the area under cassava cultivation. Two farms had some whitefly infestation but of insignificant number. Other pests such as moles, nematodes and mealybugs as well as cassava bacterial blight disease were also observed.

In general, most farms were well weeded and cassava plants including those that had CMD-like symptoms appeared strong sustaining vigorous growth.

In Kwale, some cassava plants showed mottling symptoms in addition to the typical CMD symptoms described in section 1.2.1. There were no signs of whitefly-transmitted infection as the young cassava sprouts already showed clear CMD symptoms. Despite presence of CMD, farmers were unaware of the impact of the disease and the considerable yield losses. CMD here was regarded as an aberrant growth behaviour. Production was stable and generally regarded as satisfactory.

Western and Nyanza provinces: Popular cassava varieties found in Western and Nyanza provinces include Adhiambolela, Serere, Obwanaterani, Muwumba, Siprosa, Mwakamoja and Habune. Most farms that had no intercrops were not well weeded while those with intercrops of less importance to farmers attracted little attention. In Busia, Bungoma, Kakamega and Teso districts, cassava was intercropped mainly with maize, millet, tobacco, kales, sorghum and in rare cases with bananas. The area under cassava had been reduced drastically and cassava was being replaced with sugarcane, sweet potatoes and maize. In Siaya, Vihiga and Suba districts, cassava was intercropped with sorghum, maize, millet, sweet potato and bananas. Besides, some farmers were replacing cassava with sweet potato and sorghum. In Suba district this crop shift was not as drastic as in Siaya, Busia and Teso districts.

Although farmers in the two provinces, hardly got harvestable tubers from cassava, like in the Coast province, most of them were not aware of the disastrous effects of

the virus disease and blamed the deteriorating cassava yields on aging soils. Many cassava plants were showing severe CMD symptoms but still sustained a vigorous growth on fertile soils. Despite the vigorous growth, plants failed to produce tubers and instead, the cutting used for propagation enlarged and looked like a tuber. There was no selection of planting material in favour of cuttings taken from symptomless cassava plants as farmers were planting own or seed from neighbours. Some had gone as far as across the border into Uganda in search of high yielding planting material.

In both provinces, only few whiteflies were seen on one cassava plant. Apparently, moles were the most important pests in the whole area. Cassava cuttings imported from the International Institute of Tropical Agriculture (IITA) (Uganda and Nigeria) and thought to be resistant to CMD had been planted at multiplication sites at Alupe, Busia F.T.C (Farmers' Training Center) and Siaya F.T.C. These cassava plants were heavily infested with cassava green mite (*Mononychellus anajoa* Bondar) and some had CMD-like symptoms.

3.3.4 CMD severity and incidence

Coast province: The highest CMD incidence of 50% was observed in a farm intercropped with cashew nuts while the lowest incidence of 23% was observed in a farm intercropped with bananas in Kwale district. Severity score ranged from 1.5 in two varieties, Kibandameno and Number 4, to 2.8 in the variety Kibeso. Generally, disease severity seemed to increase with the number of generations from an infected mother plant.

Western and Nyanza provinces: A disease incidence of up to 100% was evident in most farms and there was hardly a farm with a CMD incidence below 50%. Severity scores ranged from 2.4 to 4.5. The lowest severity score of 2.4 was observed in resistant material (variety Amygera, obtained from IITA in Uganda), which was still at the multiplication stages. Despite its CMD resistance level, this material showed a high susceptibility to the cassava green spider mite which was not the case with the most popular varieties grown in this area that appeared resistant to this pest.

At Siaya F.T.C. the agricultural officers had tried to reduce the incidence of CMD by roguing infected plants from the cassava multiplication plots, but this caused the removal of a large number of cassava plants from the plot because the infection pressure was too high.

3.3.5 Sample analysis by TAS-ELISA and PCR for cassava begomoviruses

TAS-ELISA was performed for virus detection and differentiation as indicated above in section 2.3.3.3. using polyclonal antisera against ACMV for coating and the MAbs that reacted specifically with respective viruses (Table 11). In this test, the MAb 6E9 was not included in TAS-ELISA since it was not available at the time of the experiments.

PCR was performed using specific primer combinations designated by I, II and III. Primer combination I is specific for detecting ACMV, II is specific for EACMV and III, specific for UgV.

The results of this investigation on virus types detected in cassava sample are summarized in Fig. 19 and Table 12.

Table 12. Detection of begomoviruses in CMD-infected cassava samples from different districts in Kenya by PCR and TAS-ELISA.

| Sample No. | Sample origin District | Virus detected | Primer combination | | | Mab (TAS-ELISA) | | | |
|------------|---------------------------|----------------|--------------------|----|-----|-----------------|-----|-----|-----|
| | | | I | II | III | 4F10 | 1C1 | 1H2 | 4G7 |
| 150 | Bungoma | UgV | - | - | + | + | + | + | - |
| 151 | Bugoma | UgV | - | - | + | + | + | + | - |
| 65 | Busia | ACMV | + | - | - | + | + | - | - |
| 66 | Busia | ACMV | + | - | - | + | + | - | - |
| 67 | Busia | ACMV | + | - | - | + | + | - | - |
| 106 | Busia | UgV | - | - | + | + | + | + | - |
| 111 | Busia | UgV | - | - | + | + | + | + | - |
| 157 | Busia | EACMV | - | + | - | - | + | + | - |
| 158 | Busia | UgV | - | - | + | + | + | + | - |

Table 12. continued...

| Sample No. Ca... | Sample origin District | Virus detected | Primer combination | | | Mab (TAS-ELISA) | | | |
|---------------------|---------------------------|----------------|--------------------|----|-----|-----------------|-----|-----|-----|
| | | | I | II | III | 4F10 | 1C1 | 1H2 | 4G7 |
| 7 | Kakamega | ACMV + EACMV | + | + | - | + | + | + | - |
| 18 | Kakamega | UgV | - | - | + | + | + | + | - |
| 147 | Kakamega | UgV | - | - | + | + | + | + | - |
| 148 | Kakamega | UgV | - | - | + | + | + | + | - |
| 53 | Kilifi | EACMV | - | + | - | - | + | + | - |
| 54 | Kilifi | EACMV | - | + | - | - | + | + | - |
| 104 | Kilifi | EACMV | - | + | - | - | + | + | - |
| 107 | Kilifi | EACMV | - | + | - | - | + | + | - |
| 112 | Kilifi | EACMV | - | + | - | - | + | + | - |
| 115 | Kilifi | EACMV | - | + | - | - | + | + | - |
| 122 | Kilifi | EACMV | - | + | - | - | + | + | - |
| 124 | Kilifi | EACMV | - | + | - | - | + | + | - |
| 100 | Kwale | EACMV | - | + | - | - | + | + | - |
| 110 | Kwale | EACMV | - | + | - | - | + | + | - |
| 114 | Kwale | EACMV | - | + | - | - | + | + | - |
| 119 | Kwale | EACMV | - | + | - | - | + | + | - |
| 120 | Kwale | EACMV | - | + | - | - | + | + | - |
| 123 | Kwale | EACMV | - | + | - | - | + | + | - |
| 125 | Kwale | EACMV | - | + | - | - | + | + | - |
| 126 | Kwale | EACMV | - | + | - | - | + | + | - |
| 14 | Luanda | UgV | - | - | + | + | + | + | - |
| 20 | Luanda | ACMV | + | - | - | + | + | + | - |
| 21 | Luanda | ACMV | + | - | - | + | + | + | - |
| 22 | Luanda | ACMV | + | - | - | + | + | + | - |
| 2 | Siaya | UgV | - | - | + | + | + | + | - |
| 6 | Siaya | UgV | - | - | + | + | + | + | - |
| 108 | Siaya | UgV | - | - | + | + | + | + | - |
| 121 | Siaya | UgV | - | - | + | + | + | + | - |
| 127 | Siaya | UgV | - | - | + | + | + | + | - |
| 160 | Siaya | UgV | - | - | + | + | + | + | - |
| 136 | Suba | EACMV | - | + | - | - | + | + | - |
| 137 | Suba | ACMV + UgV | + | - | + | + | + | + | - |

Table 12. continued.

| Sample No. Ca... | Sample origin District | Virus detected | Primer combination | | | Mab (TAS-ELISA) | | | |
|---------------------|---------------------------|----------------|--------------------|----|-----|-----------------|-----|-----|-----|
| | | | I | II | III | 4F10 | 1C1 | 1H2 | 4G7 |
| 139 | Suba | ACMV + UgV | + | - | + | + | + | + | - |
| 140 | Suba | UgV | - | - | + | + | + | + | - |
| 141 | Suba | UgV | - | - | + | + | + | + | - |
| 142 | Suba | ACMV + UgV | + | - | + | + | + | + | - |
| 143 | Suba | UgV | - | - | + | + | + | + | - |
| 144 | Suba | ACMV + UgV | + | - | + | + | + | + | - |
| 145 | Suba | ACMV + UgV | + | - | + | + | + | + | - |
| 146 | Suba | ACMV | + | - | - | + | + | + | - |
| 101 | Teso | EACMV | - | + | - | + | + | + | - |
| 102 | Teso | UgV | - | - | + | + | + | + | - |
| 109 | Teso | UgV | - | - | + | + | + | + | - |
| 116 | Teso | ACMV + UgV | + | - | + | + | + | + | - |
| 117 | Teso | UgV | - | - | + | + | + | + | - |
| 118 | Teso | UgV | - | - | + | + | + | + | - |
| 152 | Vihiga | ACMV + UgV | + | - | + | + | + | + | - |
| 153 | Vihiga | UgV | - | - | + | + | + | + | - |
| 154 | Vihiga | ACMV + UgV | + | - | + | + | + | + | - |
| 155 | Vihiga | ACMV | + | - | - | + | + | + | - |
| 156 | Vihiga | ACMV | + | - | - | + | + | + | - |

* Primer combination as described in Table 4:

I – ACMV AL1/F // ACMV ARO/R specific for ACMV

II – EACMV T588U20 // UV Eco CP specific for EACMV

III – UV AL1/F1 // UgV 1129 specific for UgV

Using ELISA and PCR neither ACMV nor UgV were detected in samples from Kilifi and Kwale districts at the Coastal areas of Kenya. All the 30 cassava samples tested positive for EACMV only.

In Western and Nyanza provinces, the three cassava begomoviruses ACMV, EACMV and UgV were detected by the two methods. In addition, PCR results showed that 52.2% of the infected cassava samples in the two provinces were infected with UgV and 21.7% with ACMV while 17.4% had mixed infections of UgV and ACMV. EACMV was detected only in 3 samples, Ca101 from Alupe in Teso

district, at the Kenya-Uganda border, Ca157 from Busia district near lake Victoria and Ca136 found from Mbita in Suba district. One sample from Kagamega (Ca007) had a mixed infection of EACMV and ACMV.

Most samples from the districts of Busia, Teso, Siaya, Kakamega and Bungoma, tested positive for UgV even though ACMV was previously known to be the predominant virus in this area.



Figure 19. Map of Kenya showing the areas from which cassava samples were collected. Types of begomoviruses detected in the cassava growing regions are indicated by coloured dots.

3.4 Distribution of cassava begomoviruses in Africa

3.4.1 Analysis of CMD affected cassava materials from Africa

All samples received from or collected in several cassava growing countries of Africa (Table 1, section 2.1.1) were tested by TAS-ELISA as well as by PCR, to detect and to discriminate between cassava begomoviruses using the Mab combinations, 4F10, 1C1 and 4G7 (Table 12) and the differential primer pair combinations described in section 2.6.7 (Table 3). Results of this study are presented in Table 13 and Fig.20.

Table 13. Identification of begomovirus types in CMD-affected cassava samples collected from various African countries.

| Sample No. Ca... | Sample origin Country | Location | Virus detected | Primer combination | | | Mab TAS-ELISA | | |
|---------------------|--------------------------|--------------|----------------|--------------------|----|-----|---------------|-----|-----|
| | | | | I | II | III | 4F10 | 1C1 | 4G7 |
| 82 | D.R. Congo | Bas Mboka | ACMV + UgV | + | - | + | + | + | - |
| 86 | D.R. Congo | Bas Musongul | ACMV + UgV | + | - | + | + | + | - |
| 172 | D.R. Congo | Elongo | ACMV + UgV | + | - | + | + | + | - |
| 171 | D.R. Congo | Ikelenoke | ACMV | + | - | - | + | + | - |
| 176 | D.R. Congo | Kafuka | ACMV + UgV | + | - | + | + | + | - |
| 177 | D.R. Congo | Kelenga | ACMV + UgV | + | - | + | + | + | - |
| 173 | D.R. Congo | Mbongo | ACMV + UgV | + | - | + | + | + | - |
| 175 | D.R. Congo | Ndjiko | ACMV + UgV | + | - | + | + | + | - |
| 174 | D.R. Congo | Ronana | UgV | - | - | + | + | + | - |
| 178 | D.R. Congo | Yafela | UgV | - | - | + | + | + | - |
| 80 | D.R. Congo | Kinshasa | ACMV | + | - | - | + | + | - |
| 81 | D.R. Congo | Kinshasa | ACMV | + | - | - | + | + | - |
| 84 | D.R. Congo | Kinshasa | ACMV | + | - | - | + | + | - |
| 87 | D.R. Congo | Kinshasa | ACMV | + | - | - | + | + | - |
| 69 | D.R. Congo | Kisangani | ACMV + UgV | + | - | + | + | + | - |
| 70 | D.R. Congo | Kisangani | UgV | - | - | + | + | + | - |
| 73 | D.R. Congo | Kisangani | ACMV + UgV | + | - | + | + | + | - |
| 179 | D.R. Congo | Kisangani | UgV | - | - | + | + | + | - |
| 180 | D.R. Congo | Kisangani | ACMV | + | - | - | + | + | - |
| 181 | D.R. Congo | Kisangani | ACMV | + | - | - | + | + | - |
| 182 | D.R. Congo | Kisangani | ACMV + UgV | + | - | + | + | + | - |
| 183 | D.R. Congo | Kisangani | ACMV + UgV | + | - | + | + | + | - |
| 184 | D.R. Congo | Kisangani | ACMV + UgV | + | - | + | + | + | - |
| 185 | D.R. Congo | Kisangani | UgV | - | - | + | + | + | - |
| 186 | D.R. Congo | Kisangani | ACMV + UgV | + | - | + | + | + | - |
| 187 | D.R. Congo | Kisangani | ACMV | + | - | - | + | + | - |
| 77 | Ghana | NN | ACMV | + | - | - | + | + | - |
| 78 | Ghana | NN | ACMV | + | - | - | + | + | - |
| 79 | Ghana | NN | ACMV | + | - | - | + | + | - |
| 35 | Guinea | NN | ACMV + EACMV | + | + | - | - | + | - |
| 41 | Guinea | NN | ACMV | + | - | + | + | + | - |
| 42 | Guinea | NN | ACMV | + | - | - | + | + | - |
| 76 | Guinea | NN | ACMV | + | - | - | + | + | - |
| 36 | India | Trivanan | ICMV | - | - | - | - | - | + |
| 23 | Madagascar | Atanarivo | ACMV | + | - | - | + | + | - |
| 25 | Madagascar | Atanarivo | ACMV | + | - | - | + | + | - |
| 28 | Madagascar | Atanarivo | ACMV | + | - | - | + | + | - |
| 30 | Nigeria | Isumi K. | ACMV | + | - | - | + | + | - |
| 31 | Nigeria | Isumi K. | ACMV | + | - | - | + | + | - |
| 32 | Nigeria | Isumi K. | ACMV | + | - | - | + | + | - |
| 33 | Nigeria | Isumi K. | ACMV | + | - | - | + | + | - |

Table 13. continued.

| Sample No. Ca... | Sample origin Country | Location | Virus detected | Primer combination | | | Mab TAS-ELISA | | |
|---------------------|--------------------------|--------------|----------------|--------------------|----|-----|---------------|-----|-----|
| | | | | I | II | III | 4F10 | 1C1 | 4G7 |
| 34 | Nigeria | Isumi K. | ACMV | + | - | - | + | + | - |
| 161 | Nigeria | Ibadan | 'EACMV | - | + | - | - | + | - |
| 12 | Togo | Wouliazou K. | ACMV | + | - | - | + | + | - |
| 15 | Togo | Linsan | ACMV | + | - | - | + | + | - |
| 17 | Togo | Foulaya | ACMV | + | - | - | + | + | - |
| 19 | Togo | Boubouya | ACMV | + | - | - | + | + | - |
| 26 | Togo | Obetail | ACMV | + | - | - | + | + | - |
| 27 | Togo | Boke | ACMV | + | - | - | + | + | - |
| 29 | Togo | Sinta | ACMV | + | - | - | + | + | - |
| 37 | Togo | Kourania | ACMV | + | - | - | + | + | - |
| 39 | Togo | Yonya | ACMV | + | - | - | + | + | - |
| 43 | Togo | Bensenken | ACMV | + | - | - | + | + | - |
| 44 | Togo | Boubouya | ACMV | + | - | - | + | + | - |
| 46 | Togo | boucherie | ACMV | + | - | - | + | + | - |
| 51 | Togo | Khola Kourè | ACMV | + | - | - | + | + | - |
| 56 | Togo | Khola Kourè | ACMV | + | - | - | + | + | - |
| 57 | Togo | Foulaya | ACMV | + | - | - | + | + | - |
| 61 | Togo | Foulaya | ACMV | + | - | - | + | + | - |
| 64 | Togo | Samaya | ACMV | + | - | - | + | + | - |
| 68 | D.R.Congo | Kisangani | UgV | - | - | + | + | + | - |
| 71 | Togo | Khola Kourè | ACMV | + | - | - | + | + | - |
| 74 | Togo | Tolo Bengu | ACMV | + | - | - | + | + | - |
| 164 | Togo | NN | ACMV | + | - | - | + | + | - |
| 165 | Togo | NN | ACMV | + | - | - | + | + | - |
| 166 | Togo | NN | ACMV | + | - | - | + | + | - |
| 167 | Togo | NN | ACMV | + | - | - | + | + | - |
| 168 | Togo | NN | ACMV | + | - | - | + | + | - |
| 169 | Togo | NN | ACMV | + | - | - | + | + | - |
| 170 | Togo | NN | ACMV | + | - | - | + | + | - |
| 3 | Uganda | Nyenga | UgV | - | - | + | + | + | - |
| 4 | Uganda | Nyenga | UgV | - | - | + | + | + | - |
| 5 | Uganda | Nyenga | ACMV + UgV | + | - | + | + | + | - |
| 9 | Uganda | Busiu | UgV | - | - | + | + | + | - |
| 10 | Uganda | Kamuli | UgV | - | - | + | + | + | - |
| 11 | Uganda | Kamuli | UgV | - | - | + | + | + | - |
| 13 | Uganda | Nyenga | UgV | - | - | + | + | + | - |
| 16 | Uganda | Ngiya | UgV | - | - | + | + | + | - |
| 58 | Zambia | Ndasemana | ACMV | + | - | - | + | + | - |
| 59 | Zambia | Chanda | ACMV | + | - | - | + | + | - |
| 60 | Zambia | Kalipopo | ACMV | + | - | - | + | + | - |
| 62 | Zambia | Chanda 2 | ACMV | + | - | - | + | + | - |
| 63 | Zambia | Ndasemana 2 | ACMV | + | - | - | + | + | - |

3.4.2 Distribution of ACMV, EACMV, and UgV in Africa

Based on ELISA- and PCR- results of samples collected between 1997 and 2001 from Africa, a distribution map of cassava begomoviruses occurring in Africa has been drawn (Fig.20). Cassava growing regions in Africa range from the savannah zones of the Sahel to the northern regions of South Africa. ACMV was detected in at least one sample from all cassava growing countries of Africa.

EACMV was the only cassava begomovirus detected in samples collected along the coast of Kenya and Madagascar, albeit there were a few isolated cases of the virus in Western areas of Kenya around lake Victoria. However, no EACMV was detected in samples obtained from Uganda. EACMV was also detected in samples from Guinea and Nigeria.

The recombinant virus UgV was found in samples from Western Kenya, Uganda and the Democratic Republic of the Congo. The DRC is the largest cassava consuming country in Africa. The virus was most prevalent in Orientale region around Kisangani, and the Bas Congo area extending from Kinshasa South West wards towards Republic of the Congo and Angola. This was the Western most region of Africa where UgV was found in the year 2000.

The South African cassava mosaic virus (SACMV) has been reported only in South Africa (Rey and Thompson, 1998) and this virus is included in this map although it was never found in any of the samples analysed. Hence SACMV is so far reported only from South Africa but with a hitherto undefined epidemiological significance.

The distinct species ICMV was not found in any of the cassava samples from Africa and is therefore still a virus with a geographical distribution restricted to India alone.

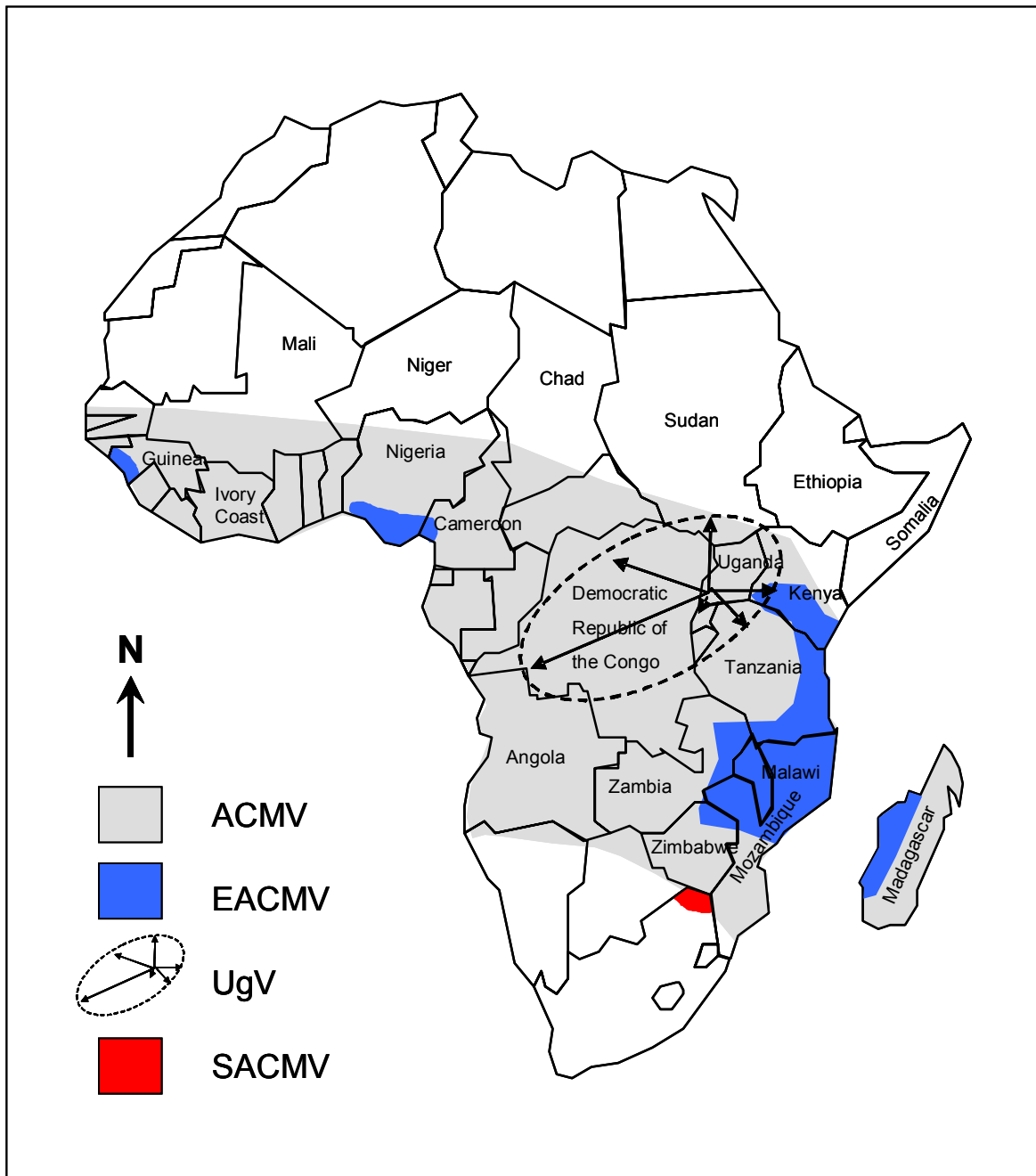

Figure 20. Map of Africa showing the distribution of cassava begomoviruses in cassava growing countries.

3.5 Sequence analysis

3.5.1 Amplification and analysis of DNA-A genomic components

The strategy followed to retrieve full-length DNA-A for different begomoviruses using an abutting primer procedure with oligonucleotides positioned at a single, unique restriction site of DNA-A, resulted in amplicons of approximately 2800 bp.

Full-length PCR products were obtained for different cassava begomoviruses previously defined by TAS-ELISA and PCR, however, for sequence analysis, only a limited number of DNA-A genomic components was cloned and further analyzed. The DNA-A clones used in sequence analysis were representatives of all cassava begomoviruses obtained in this study.

For a more detailed investigation, coat protein genes were amplified, cloned and sequenced in order to gather information on the variability of coat protein sequences and, to specifically define variations of the putative recombination events within UgV coat protein genes.

Sequence alignments were done using the multiple sequence alignment application of DNAMAN and the aligned sequences were used to construct phylogenetic trees. This was done using the sequence distance method that utilizes the neighbour joining algorithm of Saitou and Nei (1987). The confidence values for the grouping within a tree, a bootstrap analysis (Felsenstein, 1985), was performed using a value of 1000. Sequences of African cassava mosaic viruses and East African cassava mosaic viruses available at GenBank and EMBL (Appendix) were used for direct comparison and cowpea golden mosaic virus, CPGMV, was selected as an out-group virus sequence.

3.5.2 Comparison of coat protein genes

Since the “new” type of begomovirus was described having a coat protein with a deviant composition (Zhou *et al.*, 1997) the analysis of coat protein sequence was a prerequisite for all further investigations.

Coat protein gene (CP) sequences of ACMV, EACMV and UgV virus types previously typified by TAS-ELISA and PCR, were amplified from CMD-affected cassava obtained from different locations, cloned as described in section 2.7.2 and sequenced. To define putative recombination events, the nucleotide sequences were aligned and further examined for critical sequence elements within the coat protein genes.

Cassava begomoviral CPs analyzed were approximately 780 nucleotides. Clustal W alignments revealed a high degree of nucleotide (nt) sequence identity with >97% identical nt sequences for ACMV isolates, about 96% identical nt sequences for EACMV isolates and 99% identical nt sequences for UgV isolates. The clusters formed (Fig. 21) defined separate groups with ACMV and UgV type coat protein sequences forming a branch (>89% identical sequences among all sequences of ACMV and UgV coat protein genes) that is well separated from that of EACMV (75-77% identical sequences) and also SACMV (75% identical sequences).

A comparison of the 258 amino acid (aa) sequences comprising the coat protein genes resulted in an identical tree structure with EACMV and SACMV amino acid sequences forming a well separated cluster from those formed by ACMV and UgV. This provided further evidence that the coat protein of UgV is more closely related to ACMV than to EACMV or SACMV.

An interesting observation for aa sequences of ACMV isolates was that a diversion into geographic origin could be resolved, with isolates from Kenya and Uganda separated from those of Nigeria and Cameroon (Fig. 21).

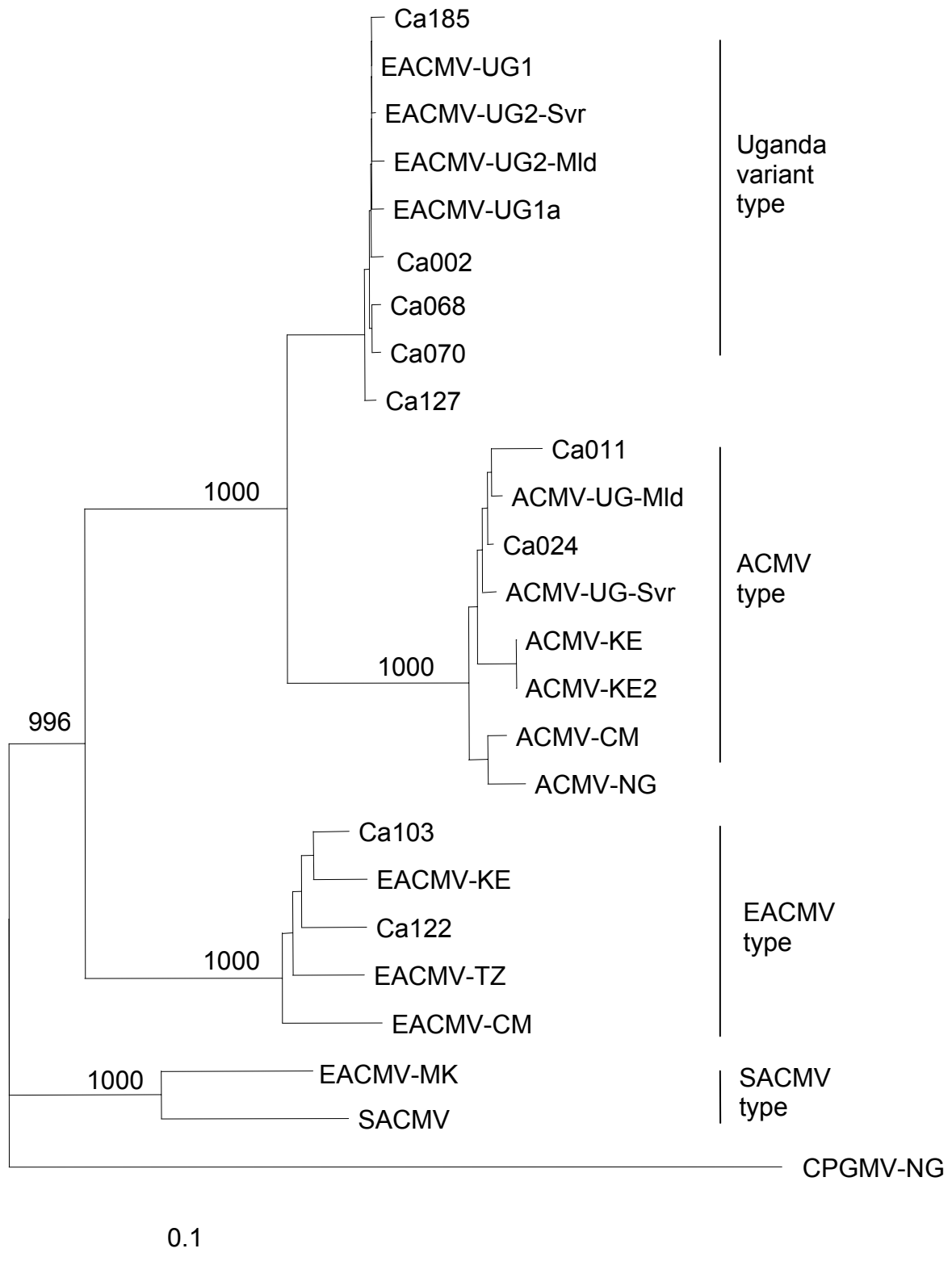

Figure 21. Phylogenetic tree constructed from nucleotide sequence alignments of coat protein genes of cassava begomoviruses. The coat protein gene of cowpea golden mosaic virus, CPGMV, was used as an out-group.

When nucleotide sequence alignments of the coat protein genes were analysed in more detail, sequences located at 5'-terminal, core and at 3'- terminal regions of the coat protein gene showed a varying sequence identity grouping (Fig. 22).

```

ACMV-KE      ATGTCGAAGCGACCAGGAGATATCATCATTTCCTCCAGGATCCAAGGTTTCGTGCGAAGA
Af126802    ATGTCGAAGCGACCAGGAGATATCATCATTTCCTCCAGGCTCCAAGGTTTCGTGCGAAGA
Ca011       ATGTCGAAGCGACCAGGAGATATCATCATTTCCTCCAGGCTCCAAGGTTTCGTGCGAAGA
EACMV-UG1   ATGTCGAAGCGACCAGGAGATATAATAATCTCAACACCCGTATCCAAGGTGCGGAGGAGG
Ca127      ATGTCGAAGCGACCAGGAGATATAATAATCTCAACACCCGTATCCAAGGTGCGGAGGAGG
EACMV-UG2-Svr ATGTCGAAGCGACCAGGAGATATAATAATCTCAACACCCGTATCCAAGGTGCGGAGGAGG
EACMV-UG2-Mld ATGTCGAAGCGACCAGGAGATATAATAATCTCAACACCCGTATCCAAGGTGCGGAGGAGG
Ca002      ATGTCGAAGCGACCAGGAGATATAATAATCTCAACACCCGTATCCAAGGTGCGGAGGAGG
Ca103      ATGTCGAAGCGACCAGGAGATATAATAATCTCAACACCCGTATCCAAGGTGCGGAGGAGG
Ca122      ATGTCGAAGCGACCAGGAGATATAATAATCTCAACACCCGTATCCAAGGTGCGGAGGAGG
EACMV-KE    ATGTCGAAGCGACCAGGAGATATAATAATCTCAACACCCGTATCCAAGGTGCGGAGGAGG
EACMV-TZ    ATGTCGAAGCGACCAGGAGATATAATAATCTCAACACCCGTATCCAAGGTGCGGAGGAGG
*****

```

```

ACMV-KE      CTGAACTTCGACAGCCCATACAGGAACCGTGCTACTGCCCCACTGTCCACGTACAAAA
ACMV-UG-Svr CTGAACTTCGACAGCCCATACAGGAACCGTGCTACTGCCCCACTGTCCACGTACAAAA
Ca011       CTGAACTTCGACAGCCCATACAGGAACCGTGCTACTGCCCCACTGTCCACGTACAAAA
EACMV-UG1   CTGAACTTCGACAGCCCATACAGGAACCGTGTTGTTGCCCCACTGTCCGCGTCACCAGA
Ca127      CTGAACTTCGACAGCCCATACAGGAACCGTGTTGTTGCCCCACTGTCCGCGTCACCAGA
EACMV-UG2-Svr CTGAACTTCGACAGCCCATACAGGAACCGTGTTGTTGCCCCACTGTCCGCGTCACCAGA
EACMV-UG2-Mld CTGAACTTCGACAGCCCATACAGGAACCGTGTTGTTGCCCCACTGTCCGCGTCACCAGA
Ca002      CTGAACTTCGACAGCCCATACAGGAACCGTGTTGTTGCCCCACTGTCCGCGTCACCAGA
Ca103      CTGAACTTCGACAGCCCATACAGGAACCGTGTTGTTGCCCCACTGTCCGCGTCACCAGA
Ca122      CTGAACTTCGACAGCCCATACAGGAACCGTGTTGTTGCCCCACTGTCCGCGTCACCAGA
EACMV-KE    CTGAACTTCGACAGCCCATACAGGAACCGTGTTGTTGCCCCACTGTCCGCGTCACCAGA
EACMV-TZ    CTGAACTTCGACAGTCCATATACAGGAACCGTGTTGTTGCCCCACTGTCCGCGTCACCAGA
*****

```

```

ACMV-KE      CGAAAACGGGCCGTTGGTGAACAGGCCCATGTACAGAAAGCCACGATGTACAGGATGTAT
ACMV-UG-Svr CGAAAACGGGCCGTTGGTGAACAGGCCCATGTACAGAAAGCCACGATGTACAGGATGTAT
Ca011       CGAAAACGGGCCGTTGGTGAACAGGCCCATGTACAGAAAGCCACGATGTACAGGATGTAT
EACMV-UG1   AGCAAAA--ATAAGGGCCAACAGGCCCATGTATCGGAAACCCAAGATGTACAGAATGTAT
Ca127      AGCAAAA--ATAAGGGCCAACAGGCCCATGTATCGGAAACCCAAGATGTACAGACTGTAT
EACMV-UG2-Svr AGCAAAA--ATAAGGGCCAACAGGCCCATGTATCGGAAACCCAAGATGTACAGAATGTAT
EACMV-UG2-Mld AGCAAAA--ATAAGGGCCAACAGGCCCATGTATCGGAAACCCAAGATGTACAGAATGTAT
Ca002      AGCAAAA--ATAAGGGCCAACAGGCCCATGTATCGGAAACCCAAGATGTACAGAATGTAT
Ca103      AGCAAAA--ATAAGGGCCAACAGGCCCATGTATCGGAAAGCCCAAGATGTACAGAATGTAT
Ca122      AGCAAAA--ATAAGGGCCAACGGGCCCATGTACCGGAAGCCCAAGATGTACAGAATGTAT
EACMV-KE    AGCAAAA--ATAAGGGCCAACAGGCCCATGTATCGGAAAGCCCAAGATGTACAGAATGTAT
EACMV-TZ    AGCAAAA--ATAAGGGCCAACAGGCCCATGTATCGGAAAGCCCAAGATGTACAGAATGTAT
*   *   *   *   *   *   *   *   *   *   *   *   *   *   *   *   *

```

```

ACMV-KE      AGAAGCCCAGACATACCTAGGGGCTGTGAAGGCCCATGTAAGGTCAGTCGTTTGAGCAG
ACMV-UG-Svr AGAAGCCCAGACATACCTAGGGGCTGTGAAGGCCCATGTAAGGTCAGTCGTTTGAGCAG
Ca011       AGAAGCCCAGACATACCTAGGGGCTGTGAAGGCCCATGTAAGGTCAGTCGTTTGAGCAG
EACMV-UG1   CGAAGCCCAGATGTCCTAAGGGCTGTGAAGGCCCATGTAAGGTCAGTCGTTTGAGCAG
Ca127      CGAAGCCCAGACGTCCCTAAGGGCTGTGAAGGCCCATGTAAGGTCAGTCGTTTGAGCAG
EACMV-UG2-Svr CGAAGCCCAGATGTCCTAAGGGCTGTGAAGGCCCATGTAAGGTCAGTCGTTTGAGCAG
EACMV-UG2-Mld CGAAGCCCAGATGTCCTAAGGGCTGTGAAGGCCCATGTAAGGTCAGTCGTTTGAGCAG
Ca002      CGAAGCCCAGATGTCCTAAGGGCTGTGAAGGCCCATGTAAGGTCAGTCGTTTGAGCAG
Ca103      CGAAGCCCAGATGTCCTAAGGGCTGTGAAGGCCCATGTAAGGTCAGTCCTATGAACAG
Ca122      CGAAGCCCAGATGTCCTAAGGGCTGTGAAGGCCCATGTAAGGTCAGTCGTTTGAGCAG
EACMV-KE    CGAAGCCCAGATGTCCTAAGGGCTGTGAAGGCCCATGTAAGGTCAGTCCTATGAACAG
EACMV-TZ    CGAAGCCCAGATGTCCTAAGGGCTGTGAAGGCCCATGTAAGGTCAGTCCTATGAACAG
*****

```

| | |
|---------------|---|
| ACMV-KE | AGGGATGATGTGAAGCACCTTGGTATCTGTAAGGTGATTAAGTATGACGCGTGGGCCT |
| ACMV-UG-Svr | AGGGATGATGTGAAGCACCTTGGTATCTGTAAGGTGATTAAGTATGACGCGTGGGCCT |
| Ca011 | AGGGATGATGTGAAGCACCTTGGTATCTGTAAGGTGATTAAGTATGACGCGTGGGCCT |
| EACMV-UG1 | AGGGATGATGTGAAGCACCTTGGTATCTGTAAGGTGATTAAGTATGACGCGTGGGCCT |
| Ca127 | AGGGATGATGTGAAGCACCTTGGTATCTGTAAGGTGATTAAGTATGACGCGTGGGCCT |
| EACMV-UG2-Svr | AGGGATGATGTGAAGCACCTTGGTATCTGTAAGGTGATTAAGTATGACGCGTGGGCCT |
| EACMV-UG2-Mld | AGGGATGATGTGAAGCACCTTGGTATCTGTAAGGTGATTAAGTATGACGCGTGGGCCT |
| Ca002 | AGGGATGATGTGAAGCACCTTGGTATCTGTAAGGTGATTAAGTATGACGCGTGGGCCT |
| Ca103 | AGGGATGATGTTAAGCACACTGGTATGGTTCGATGTGTCAAGTATGTAACCTCGTGGGTCA |
| Ca122 | AGGGATGATGTTAAGCACACTGGTATGGTTCGATGTGTCAAGTATGTTACTCGTGGGTCA |
| EACMV-KE | AGGGATGATGTTAAGCACACTGGTATGGTTCGATGTGTCAAGTATGTTACTCGTGGATCA |
| EACMV-TZ | AGAGATGATGTTAAGCACACTGGTATGGTTCGATGTGTCAAGTATGTTACTCGTGGATCA |
| | ** ***** ** * * ***** * * ***** * |

| | |
|---------------|--|
| ACMV-KE | GGGCTGACACACAGGGTCGGAAAGAGGTTTTGTATCAAGTCCATTACATCTTGGTAAAG |
| ACMV-UG-Svr | GGGCTGACACACAGGGTCGGAAAGAGGTTTTGTATCAAGTCCATTACATCTTGGTAAAG |
| Ca011 | GGGCTGACACACAGGGTCGGAAAGAGGTTTTGTATCAAGTCCATTACATCTTGGTAAAG |
| EACMV-UG1 | GGGCTGACACACAGGGTCGGAAAGAGGTTTTGTATCAAGTCCATTACATCTTGGTAAAG |
| Ca127 | GGGCTGACACACAGGGTCGGAAAGAGGTTTTGTATCAAGTCCATTACATCTTGGTAAAG |
| EACMV-UG2-Svr | GGGCTGACACACAGGGTCGGAAAGAGGTTTTGTATCAAGTCCATTACATCTTGGTAAAG |
| EACMV-UG2-Mld | GGGCTGACACACAGGGTCGGAAAGAGGTTTTGTATCAAGTCCATTACATCTTGGTAAAG |
| Ca002 | GGGCTGACACACAGGGTCGGAAAGAGGTTTTGTATCAAGTCCATTACATCTTGGTAAAG |
| Ca103 | GGTATTACCCATAGAGTCGGGAAGAGGTTTTGTGTGAAGTCCATATATATATTGGGCAAG |
| Ca122 | GGCATTACCCATAGAGTCGGGAAGAGGTTTCTGTGTGAAGTCCATATATATATTGGGCAAG |
| EACMV-KE | GGCATTACCCATAGAGTCGGGAAGAGGTTTTGTGTGAAGTCCATATATATATTGGGCAAG |
| EACMV-TZ | GGTATTACCCATAGAGTCGGGAAGAGGTTTTGTGTGAAGTCCATATATATATTGGGCAAG |
| | ** |

| | |
|---------------|---|
| ACMV-KE | ATCTGGCTGGATGAAACTATTAAGAAGCAAATCACACTAATAATGTGATTTTTACCTG |
| ACMV-UG-Svr | ATCTGGATGGATGAAATATCAAGAAGCAGAATCACACTAATAATGTGATTTTTACCTG |
| Ca011 | ATCTGGATGGATGAAATATTAAGAAGCAGAATCACACTAATAATGTGATTTTTACCTG |
| EACMV-UG1 | ATCTGGATGGATGAAATATTAAGAAGCAGAATCACACTAATAATGTGATTTTTACCTG |
| Ca127 | ATCTGGATGGATGAAATATTAAGAAGCAGAATCACACTAATAATGTGATTTTTACCTG |
| EACMV-UG2-Svr | ATCTGGATGGATGAAATATTAAGAAGCAGAATCACACTAATAATGTGATTTTTACCTG |
| EACMV-UG2-Mld | ATCTGGATGGATGAAATATTAAGAAGCAGAATCACACTAATAATGTGATTTTTACCTG |
| Ca002 | ATCTGGATGGATGAAATATTAAGAAGCAGAATCACACTAATAATGTGATTTTTACCTG |
| Ca103 | ATCTGGATGGATGAGAATATCAAGAAGCAAATCATAACGACCATGTGATGTTCTTCCTT |
| Ca122 | ATTTGGATGGATGAGAATATCAAGAAGCAAACCATACGACCATGTTATGTGTTTTCCTT |
| EACMV-KE | ATCTGGATGGATGAGAATATCAAGAAGCAAATCATAACGACCATGTTATGTGTTCTTCCTT |
| EACMV-TZ | ATCTGGATGGATGAGAATATCAAGAAGCAAATCATAACGACCATGTTATGTGTTCTTCCTT |
| | ** ** |

| | |
|---------------|---|
| ACMV-KE | CTTAGGGATAGAAGGCCGTATGGCAATGCGCCCCAAGACTTTGGGCAGATATTTAACATG |
| ACMV-UG-Svr | CTTAGGGATAGAAGGCCCTTATGGCAATGCGCCCCAAGACTTTGGGCAGATATTTAACATG |
| Ca011 | CTTAGGGATAGAAGGCCCTTATGGCAATGCGCCCCAAGACTTTGGGCAGATATTTAACATG |
| EACMV-UG1 | CTTAGGGATAGAAGGCCGTATGGCAATGCGCCCCAAGACTTTGGGCAGATATTTAACATG |
| Ca127 | CTTAGGGATAGAAGGCCGTATGGCAATGCGCCCCAAGACTTTGGGCAGATATTTAACATG |
| EACMV-UG2-Svr | CTTAGGGATAGAAGGCCGTATGGCAATGCGCCCCAAGACTTTGGGCAGATATTTAACATG |
| EACMV-UG2-Mld | CTTAGGGATAGAAGGCCGTATGGCAATGCGCCCCAAGACTTTGGGCAGATATTTAACATG |
| Ca002 | CTTAGGGATAGAAGGCCGTATGGCAATGCGCCCCAAGACTTTGGGCAGATATTTAACATG |
| Ca103 | GTGCGAGATAGAAGGCCCTTATGGTCCGAGTCTCAAGATTTGGACAAGTGTCAACATG |
| Ca122 | GTGCGAGATAGAAGGCCCTTATGGTCCGAGTCCGCAAGATTTGGACAAGTGTCAACATG |
| EACMV-KE | GTGCGAGATAGAAGGCCCTTATGGTCCGAGTCTCAAGACTTTGGACAAGTGTCAACATG |
| EACMV-TZ | GTTTCGTAGATAGAAGGCCGTATGGTCCGAGTCTCAAGATTTGGACAAGTGTCAACATG |
| | * |

| | |
|---------------|--|
| ACMV-KE | TTTGATAATGAGCCAGTACTGCAACAATTAAGAACGATTTGAGGGATAGGTTTCAGGTG |
| ACMV-UG-Svr | TTTGATAATGAGCCAGTACTGCAACAATTAAGAACGATTTGAGGGATAGGTTTCAGGTG |
| Ca011 | TTCGATAATGAGCCAGTACTGCAACAATTAAGAACGATTTGAGGGATAGGTTTCAGGTG |
| EACMV-UG1 | TTTGATAATGAGCCAGTACTGCAACAATTAAGAACGATTTGAGGGATAGGTTTCAGGTG |
| Ca127 | TTTGATAATGAGCCAGTACTGCAACAATTAAGAACGATTTGAGGGATAGGTTTCAGGTG |
| EACMV-UG2-Svr | TTTGATAATGAGCCAGTACTGCAACAATTAAGAACGATTTGAGGGATAGGTTTCAGGTG |
| EACMV-UG2-Mld | TTTGATAATGAGCCAGTACTGCAACAATTAAGAACGATTTGAGGGATAGGTTTCAGGTG |
| Ca002 | TTTGATAATGAGCCAGTACTGCTACAATTAAGAACGATTTGAGGGATAGGTTTCAGGTG |
| Ca103 | TTCGATAATGAACCTACTACTGCAACTGTGAAAAATGATCTTAGGGACCGGTATCAGGTG |
| Ca122 | TTTGATAATGAACCTACTACTGCAACTGTGAAGAATGATCTTAGGGACCGGTATCAGGTG |
| EACMV-KE | TTTGATAATGAACCTACAACCGCAACTGTGAAGAATGATCTTAGGGACCGGTATCAGGTG |
| EACMV-TZ | TTTGATAATGAACCTACGACAGCGACTGTGAAGAATGATCTTAGGGACCGGTATCAGGTG |
| | ** ***** |

| | |
|-------------|---|
| ACMV-KE | TTGAGGAAATTTTCATGCCACTGTTGTTGGTGGTCCATATGGCATGAAGGAGCAGGCGTTG |
| ACMV-UG-Svr | TTGAGGAAATTTTCATGCCACTGTTGTTGGTGGTCCATCTGGCATGAAGGAGCAGGCGTTG |
| Ca011 | TTGAGGAAATTTTCATGCCACTGTAGTTGGTGGTCCATCAGGCATGAAGGAGCAGGCGTTG |
| EACMV-UG1 | TTGAGGAAATTTTCATGCCACTGTTGTTGGTGGTCCATCTGGCATGAAGGAGCAGGCGTTG |
| Ca127 | TTGAGGAAATTTTCATGCCACTGTTGTTGGTGGTCCATCTGGCATGAAGGAGCAGGCGTTG |

| | |
|---------------|---|
| EACMV-UG2-Svr | TTGAGGAAATTTTCATGCCACTGTTGTTGGTGGTCCATCTGGCATGAAGGAGCAGGCGTTG |
| EACMV-UG2-Mld | TTGAGGAAATTTTCATGCCACTGTGGTTGGTGGTCCATCTGGCATGAAGGAGCAGGCGTTG |
| Ca002 | TTGAGGAAATTTTCATGCCACTGTTGTTGGTGGTCCATCTGGCATGAAGGAGCAAGCGTTG |
| Ca103 | TTACGTAAATTTCTATGCGACTGTTGTTGGTGGACCTCTGGGATGAAGGAACAAGCTCTG |
| Ca122 | TTACGTAAATTTCTATGCGACTGTTGTTGGTGGACCTCTGGGATGAAGGAACAAGCTCTG |
| EACMV-KE | TTACGTAAATTTCTATGCGACGGTGTGGTGGACCTCTGGGATGAAGGAACAAGCTCTG |
| EACMV-TZ | TTACGTAAATTTCTATGCGACTGTTGTTGGTGGACCTCTGGGATGAAGGAGCAATCGCTG |
| | ** * ***** ** ** * ** * ** * ** * ** * ** * ** * ** * ** * |
| ACMV-KE | GTGAAAAGGTTTTACAGGTTGAATCATCACGTGACATACAATCATCAGGAGGCAGGGAAG |
| ACMV-UG-Svr | GTGAAAAGGTTTTACAGGTTGAATCATCACGTGACATATAATCATCAGGAGGCAGGGAAG |
| Ca011 | GTGAAAAGGTTTTACAGGTTGAATCATCACGTGACATATAATCATCAGGAGGCAGGGAAG |
| EACMV-UG1 | GTGAAAAGGTTTTACAAGCTGAATCATCACGTGACATATAATCATCAGGAGGCAGGGAAG |
| Ca127 | GTGAAAAGGTTTTACAAGTTGAATCATCACGTGACATATAATCATCAGGAGGCAGGGAAG |
| EACMV-UG2-Svr | GTGAAAAGGTTTTACAAGCTGAATCATCACGTGACATATAATCATCAGGAGGCAGGGAAG |
| EACMV-UG2-Mld | GTGAAAAGGTTTTACAAGCTCAATCATCACGTGACATATAATCATCAGGAGGCAGGGAAG |
| Ca002 | GTGAAAAGGTTTTACAAGCTGAATCATCACGTGACATATAATCATCAGGAGGCAGGGAAG |
| Ca103 | GTTAAGAGGTTTTTTAGGATCAATAATCATGTAGTGTATAATCATCAGGAACAGGCCAAG |
| Ca122 | GTTAAGAGGTTTTTTAGGATCAATAATCATGTAGTGTATAATCATCAGGAACAGGCCAAG |
| EACMV-KE | GTTAAGAGGTTTTTTAGGATCAATAATCATGTGTGTATAATCATCAGGAACAGGCCAAG |
| EACMV-TZ | GTCAGAGGTTTTTTAGGATTAATAATCATGTAGTGTATAATCATCAGGAACAGGCCAAG |
| | ** ** ***** * * * ** * ** * ** * ** * ** * ** * ** * ** * |
| ACMV-KE | TATGAGAATCACACAGAGAATGCTTTGCTTCTGTACATGGCATGTACTCATGCCTCCAAT |
| ACMV-UG-Svr | TATGAGAATCACACAGAGAATGCTTTGCTTTTGTACATGGCATGTACTCATGCCTCCAAT |
| Ca011 | TATGAGAATCACACAGAGAATGCTTTGCTTCTGTACATGGCATGTACTCATGCCTCCAAC |
| EACMV-UG1 | TATGAGAATCACACAGAGAATGCGTTGTTATTGTATATGGCATGTACACATGCCTCGAAT |
| Ca127 | TATGAGAATCACACAGAGAATGCGTTGTTATTGTATATGGCATGTACACATGCCTCGAAT |
| EACMV-UG2-Svr | TATGAGAATCACACAGAGAATGCGTTGTTATTGTATATGGCATGTACACATGCCTCGAAT |
| EACMV-UG2-Mld | TATGAGAATCACACAGAGAATGCGTTGTTATTGTATATGGCATGTACACATGCCTCGAAT |
| Ca002 | TATGAGAATCACACAGAGAATGCTTTGTTATTGTATATGGCATGTACACATGCCTCGAAT |
| Ca103 | TATGAGAATCATACTGAGAATGCGTTGTTATTGTATATGGCATGTACACATGCCTCGAAT |
| Ca122 | TATGAGAATCATACTGAGAATGCGTTGTTATTGTATATGGCATGTACACATGCCTCAAAT |
| EACMV-KE | TATGAGAATCATACTGAGAATGCGTTGTTATTGTATATGGCATGTACACATGCCTCGAAT |
| EACMV-TZ | TATGAGAATCATACTGAGAATGCGTTGTTATTGTATATGGCATGTACACATGCCTCGAAT |
| | ***** ** ***** ** * ***** ***** ***** ***** ** |
| ACMV-KE | CCTGTATATGCGACGTTGAAAATACGTATATACTTCTATGACAGTATTGGCAATTAA |
| ACMV-UG-Svr | CCTGTATATGCGACGTTGAAAATACGTATATAATTCTATGACAGTATTGGCAATTAA |
| Ca011 | CCTGTATATGCGACGTTGAAAATACGTATATACTTCTATGACAGTATTGGCAATTAA |
| EACMV-UG1 | CCTGTGTATGCTACGCTGAAAATACGCATCTATTTTATGATGCAGTGACAAATTA |
| Ca127 | CCTGTGTATGCTACGCTGAAAATACGCATCTATTTTATGATGCAGTGACAAATTA |
| EACMV-UG2-Svr | CCTGTGTATGCTACGCTGAAAATACGCATCTATTTTATGATGCAGTGACAAATTA |
| EACMV-UG-Mld | CCTGTGTATGCTACGCTGAAAATACGCATCTATTTTATGATGCAGTGACAAATTA |
| Ca002 | CCTGTGTATGCTACGCTGAAAATACGCATCTATTTTATGATGCAGTGACAAATTA |
| Ca103 | CCTGTGTACGCTACGCTGAAAATACGCATCTATTTCTATGATGCAGTGACAAATTA |
| Ca122 | CCTGTGTATGCTACTCTGAAAATACGCATCTATTTCTATGATGCAGTGACAAATTA |
| EACMV-KE | CCTGTGTACGCTACGCTGAAAATACGCATTTTATTCTATGATGCAGTGACAAATTA |
| EACMV-TZ | CCTGTGTACGCTACGCTGAAAATACGCATCTATTTCTATGATGCAGTGACAAATTA |
| | ***** ** * ** * ***** ** * ** * ** * ** * ** * ** * ** * |

Figure 22. Alignment of nucleotide sequences from selected coat protein genes of ACMV (ACMV-KE, ACMV-UG-SVR, Ca011), UgV (EACMV-UG1, CA127, EACMV-UG2-Svr, EACMV-UG2-Mld, Ca002) and EACMV (Ca103, Ca122, EACMV-KE, EACMV-TZ). * depicts identical sequences. Grey shaded sequences reflect ACMV type sequences, dark grey and light grey shaded areas in blocks show nucleotide sequences specific for UgV/ EACMV (dark grey) or EACMV (light grey).

The 5'- and -3' terminal sequences of the coat protein genes of UgV type viruses and EACMV were highly similar, with an invariable sequence element (red shaded area) present in both sequence types. In contrast, in the core region of UgV coat protein genes, almost identical ACMV type sequences were present

| | |
|---------------|---------------------|
| ACMV-NG | NPVYATLKIRIYFYDSIGN |
| ACMV-KE | NPVYATLKIRIYFYDSIGN |
| Ca011 | NPVYATLKIRIYFYDSIGN |
| ACMV-CM | NPVYATLKIRIYFYDSIGN |
| ACMV-UG-M1d | NPVYATLKIRIYFYDSIGN |
| ACMV-UG-Svr | NPVYATLKIRIYFYDSIGN |
| Ca002 | NPVYATLKIRIYFYDAVTN |
| Ca068 | NPVYATLKIRIYFYDAVTN |
| Ca127 | NPVYATLKIRIYFYDAVTN |
| Ca185 | NPVYATLKIRIYFYDAVTN |
| Ca070 | NPVYATLKIRIYFYDAVTN |
| EACMV-UG1A | NPVYATLKIRIYFYDAVTN |
| EACMV-UG1 | NPVYATLKIRIYFYDAVTN |
| EACMV-UG2-Svr | NPVYATLKIRIYFYDAVTN |
| EACMV-UG2-M1d | NPVYATLKIRIYFYDAVTN |
| EACMV-CM | NPVYATLKIRIYFYDAVTN |
| Ca103 | NPVYATLKIRIYFYDAVTN |
| Ca122 | NPVYATLKIRIYFYDAVTN |
| EACMV-KE | NPVYATLKIRIYFYDAVTN |
| EACMV-TZ | NPVYATLKIRIYFYDAVTN |
| | *****. . * |

Figure 23. Alignment of amino acid sequences from selected coat protein genes of ACMV (ACMV-NG, ACMV-KE, Ca011, Ca024, ACMV-CM, ACMV-UG-SVR, AF126800), UgV (Ca002, EACMV-UG1, EACMV-UG1A, Ca127, Ca068, EACMV-UG2-SVR, AF 126804) and EACMV (Ca103, AF12354, EACV06458, EACV6460, EACMVT). * depicts identical amino acid sequences . shows similar amino acids. Grey shaded areas highlight identical ACMV type amino acid sequences in 3 key motifs, while dark grey shaded area highlights a motif specific for EACMV-CM.

3.5.3 Comparison of DNA-A nucleotide sequences

Upon sequence analysis of complete DNA-A genomic components, EACMV isolates including SACMV and the *East African cassava mosaic virus* from Cameroon (ACMV-CM), formed a cluster with UgV isolates (Fig.24). However, there were a higher percentage sequence identity (approx.99%) within UgV isolates than between those of UgV and EACMV (up to 92%). The comparison also revealed that the cluster formed by these begomoviruses shared less than 80% identical nt sequences with that formed by ACMV isolates. Further nt sequence comparisons revealed a more interesting observation that ACMV isolates from the same geographical location have a higher percentage nt sequence identity than those from different geographical locations. For instance ACMV isolates from East Africa, ACMV-KE are clearly separated from those of West Africa, ACMV-NG.

The high percentage (>90%) sequence identity in DNA-A genomic components between UgV isolates and those of EACMV provides evidence that UgV is a strain of EACMV and not that of ACMV. Following the convention on naming of

geminiviruses (Fauquet *et al.*, 2000), the species name, EACMV has to precede the country of origin.

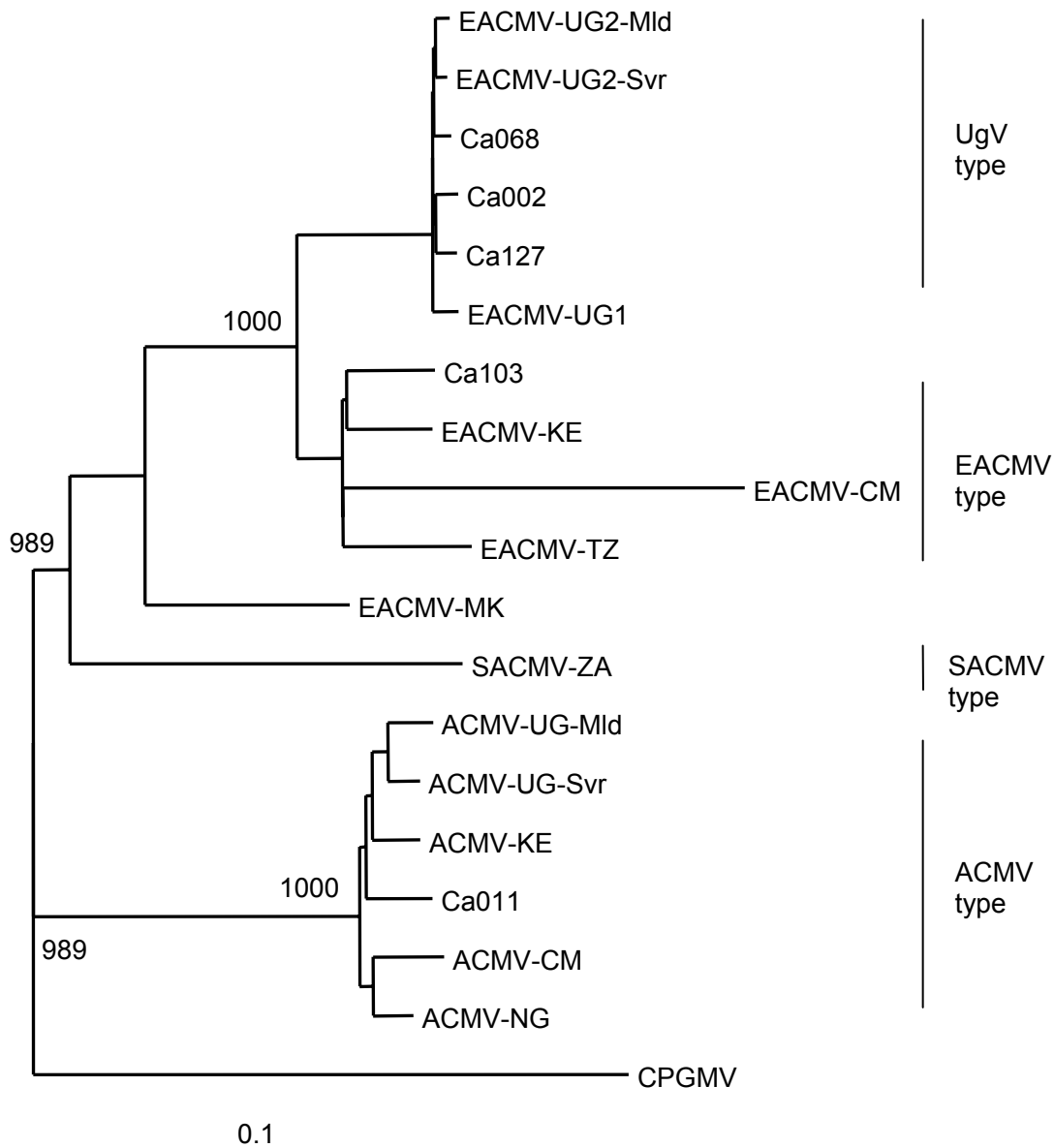

Figure 24. Phylogenetic tree constructed from nucleotide sequence alignments of DNA-A genomic components of cassava begomoviruses. DNA-A of *Cowpea golden mosaic virus*, CPGMV, was used as an out-group. Numbers reflect confidence values reached by bootstrap analysis.

3.5.4 Comparison of DNA-A intergenic regions

Intergenic regions (IRs) of geminivirus species are the genomic elements that vary most between/ among themselves. Similar or identical IR sequences between begomoviruses provide evidence for a close relationship. For instance viruses within a species have identical IR sequences while those outside a species have different IR sequences.

In the intergenic region, functional elements are located that are required for rolling cycle replication. The invariable nonameric motif 5'-TAATATTAC -3' located at the loop of a conserved hairpin element (Fig. 25) is where the Rep introduces a site specific nick, to initiate replication. This is why in this TAATATT//AC motif, the last A is defined as the nicking site and is therefore nucleotide number 1 in the circular DNA-A. In addition, a tandemly repeated motif located at variable distance to the conserved hairpin structure is bound specifically by its cognate Rep protein and functions as a major recognition site for the Rep protein of begomoviruses. Therefore, analogies in this repeated, iterated DNA elements imply close virus relationships. For related viruses, that is, viruses with highly similar iterons, Rep proteins are capable of replicating DNA-B genomic components of corresponding virus isolates or strains.

Segments of approximately 320 nt sequences of selected DNA-A genomic components ranging from just about the start of the AC1 (Rep) in the complementary sense to AV2 (the precoat protein) in the virion sense were aligned. This nucleotide comparison was performed to demonstrate sequence variability and to illustrate a common lineage for the begomoviruses infecting cassava.

ACMV-NG TTTTGACCAAGTCAATTGGAGACACTCAACTGGAGACACCCCTTGAGCATCTCCTCCTATT
Ca011 TTTTGACCAAGTCAATTGGAGACACTCAACTGGAGACACTCTTGAGCATCTTCTCCTATT
Ca024 TTTTGACCAAGTCAATTGGAGACACTCAACTAGAGACACTCTTGAGCATCTCCTCCTGTT
ACMV-CM TCTTGACCAAGTCAATTGGAGACACTCAACTAGAGACACTCTTGAGCATCTCCTCCTGTT
ACMV-UG-Svr TGTTGACCAAGTCAATTGGAGACACTCAACTAGAGACACTCTTGAGCATCTCCTCCTGTT
ACMV-KE TGTTGACCAAGTCAATTGGAGACACTCAACTAGAGACACTCTTGAGCATCTCCTCCTATT
ACMV-UG-M1d TGTTGACCAAGTCAATTGGAGACACTCAACTAGAGACACTCTTGAGCATCTCCTCCTGTT
Ca002 TATTGGCT--GTCGTTTT-----GATCGGGGACACTCAAACCTCCAGGGGAACGGT
EACMV-UG1 TATTGGCT--GTCGTTTT-----AATCGGGGACACTCAAAGTCTGTAGCAATCGGT
EACMV-UG1a TAATGGCT--GTCGTTTT-----GATCGGGGACACTCAAACCTCCAGGGGAACGGT
Ca127 TATTGGCT--GTCGTTTT-----AATCGGGGACACTCAAACCTCCAGGGGAACGGT
Ca068 TATTGGCT--GTCGTTTT-----GATCGGGGACACTCAAACCTCCAGGGGAACGGT
EACMV-UG2-Svr TATTGGCT--GTCGTTTT-----GATCGGGGACACTCAAACCTCCAGGGGAACGGT
EACMV-UG2-M1d TATTGGCT--GTCGTTTT-----GATCGGGGACACTCAAACCTCCAGGGGAACGGT
Ca103 TATTGGCT--GTCGTTTT-----GATCGGGTGCACACTCAAACCTCCAGGGGAACGGT
EACMV-CM TATTGGCT--GTCGTTTT-----GATCGGGGACACTCAAACCTCCAGGGGAACGGT
EACMV-KE TATTGGCT--GTCGTTTT-----GATCGGGGACACTCAAACCTCCAGGGGAACGGT
EACMV-MK TATTGGCT--GTCGTTTT-----GATCGGGGACACTCAAACCTCCAGGTGAATGGT
EACMV-TZ TATTGGCT--GTCGTTTT-----GATCAGGGGACACAAAGTCTATGGCAATCGGT
* * * ** *

ACMV-NG AATTGGAGACATTAATA-GTTGTCTCTAAA-TGGCATTCTTGTAAATAAGTGGTACTTTA
Ca011 AATTGGAGACATTAATA-GGTGTCTCTAAA-TGGCAGTCTTGTAAATAAGTGAACCTTTA
Ca024 AATTGGAGACATTAATA-GGTGTCTCTAAA-TGGCATTCTTGTAAATAAGTGAACCTTTA
ACMV-CM AATTGGAGACATTAATA-GTTGTCTCTAAA-TGGCATTCTGGTAATAAGTGAACCTTTA
ACMV-UG-Svr AATTGGAGACATTAATA-GGTGTCTCTAAA-TGGCATTCTGGTAATAAGTGAACCTTTA
ACMV-KE AATTGGAGACATTAATA-GGTGTCTCTAAA-TGGCATTCTTGTAAATAAGTGAACCTTTA
ACMV-UG-M1d AATTGGAGACATTAATA-GGTGTCTCTAAA-TGGCATTCTTGTAAATAAGTGAACCTTTA
Ca002 GGAATGGGGGGCATTATAATATGATGTCCCCCAA-TGGCATATGTGTAAATAGGTAGACTT
EACMV-UG1 GGAATGGGGGGCATTATAATATGATGTCCCCCAA-TGGCATATGTGTAAATAGGTAGACTT
EACMV-UG1A GGAATGGGGGGCATTATAATATGATGTCCCCCAA-TGGCATATGTGTAAATAGGTAGACTT
Ca127 GGAATGGGGGGCATTATAATATGATGTCCCCCAA-TGGCATATGTGTAAATAGGTAGACTT
Ca068 GGAATGGGGGGCATTATAATATGATGTCCCCCAA-TGGCATATGTGTAAATAGGTAGACTT
EACMV-UG2-SVR GGAATGGGGGGCATTATAATATGATGTCCCCCAA-TGGCATATGTGTAAATAGGTAGACTT
EACMV-UG2-MLD GGAATGGGGGGCATTATAATATGATGTCCCCCAA-TGGCATATGTGTAAATAGGTAGACTT
Ca103 GGAATGGTGGACATTATAATAGGATGTCCCCCAA-TGGCATTCTGTAAATAGGTAGACTT
EACMV-CM GGAATGGGGGGCATTATAATATGATGTCCCCCAA-TGGCATATGTGTAAATAGGTAGACTT
EACMV-KE GGAATGGGGGGCATTATAATAGGATGTCCCCCAA-TGGCATATGTGTAAATAGGTAGACTT
EACMV-MK GGAACGGGGGACATTATAATAGGATGTCCCCCAA-TGGCATATGTGTAAATAGGTAGACTT
EACMV-TZ GGAATGGGGGGCATTATAATATGATGTCCCCCAA-TGGCATATGTGTAAATAGGTAGACTT
* ** * ** ** ** *

ACMV-NG ATTTGAATGAAAAGGCTCAAAGGCGCAGAACACCCAAGGGGCCAACCGTATAATATT/AC
Ca011 ATTTGAATGAAAAGGCTCAAAGGCGCAGAACACCCAAGGGGCCAACCGTATAATATTAC
Ca024 ATTTGAATGAAAAGGCTCAAAGGCGCAGAACACCCAAGGGGCCAACCGTATAATATTAC
ACMV-CM ATTTGAATGAAAAGGCTCAAAGGCGCAGAACACCCAAGGGGCCAACCGTATAATATTAC
ACMV-UG-Svr ATTTGAATGAAAAGGCTCAAAGGCGCAGAACACCCAAGGGGCCAACCGTATAATATTAC
ACMV-KE ATTTGAATGAAAAGGCTCAAAGGCTCAAAGGCGCAGAACACCCAAGGGGCCAACCGTATAATATTAC
ACMV-UG-M1d ATTTGAATGAAAAGGCTCAAAGGCGCAGAACACCCAAGGGGCCAACCGTATAATATTAC
Ca002 CCATTCAA-----ATTTGAATTCGGAATATT---GGCGGCCATCCGATTAATATTAC
EACMV-UG1 CCATTCAA-----ATTTGAATTCGGAATATT---GGCGGCCATCCGATTAATATTAC
EACMV-UG1A CCATTCAA-----ATTTGAATTCGGAATATT---GGCGGCCATCCGATTAATATTAC
Ca127 CCATTCAA-----ATTTGAATTCGGAATATT---GGCGGCCATCCGATTAATATTAC
Ca068 CCATTCAA-----ATTTGAATTCGGAATATT---GGCGGCCATCCGATTAATATTAC
EACMV-UG2-Svr CCATTCAA-----ATTTGAATTCGGAATATT---GGCGGCCATCCGATTAATATTAC
EACMV-UG2-M1d CCATTCAA-----ATTTGAATTCGGAATATT---GGCGGCCATCCGATTAATATTAC
Ca103 CCATTCAA-----ATTTGAATTCGGAATATT---GGCGGCCATCCGATTAATATTAC
EACMV-CM CCATTCAA-----ATTTGAATTCGGAATATT---GGCGGCCATCCGATTAATATTAC
EACMV-KE CCATTCAA-----ATTTGAATTCGGAATATT---GGCGGCCATCCGATTAATATTAC
EACMV-MK ACATTCAA-----ATTTGAATTCGGAATAAT---GGCGGCCATCCGATTAATATTAC
EACMV-TZ CCATTGAA-----ATTTGAATTCGGAATATT---GGCGGCCATCCGATTAATATTAC
* * * * * ** ** *

ACMV-NG CGGTTGGCCCCGCCCTC-----TTTA
Ca011 CGGTTGGCCCCGCCCTC-----TTTA
Ca024 CGGTTGGCCCCGCCCTC-----TTTA
ACMV-CM CGGTTGGCCCCGCCCTC-----TTTA
ACMV-UG-Svr CGGTTGGCCCCGCCCTC-----TTTA
ACMV-KE CGGTTGGCCCCGCCCTC-----TTTA
ACMV-UG-M1d CGGTTGGCCCCGCCCTC-----TTTA
Ca002 CGGATGGCCCGCCCGAAAAA-GCAGGTGGCCCCACAA--TGACCGCGCCCGTGAAAGA
EACMV-UG1 CGGATGGCCCGCCCGAAAAA-GCAGGTGGACCCACAA--TGACCGCGCCCGTGAAAGA
EACMV-UG1A CGGATGGCCCGCCCGAAAAA-GCAGGTGGACCCACAA--TGACCGCGCCCGTGAAAGA

```

Ca127      CGGATGGCCGCGCCCGAAAAA-GCAGGTGGACCCACAA--TGACCGCGCCCGTGAAAGA
Ca068      CGGATGGCCGCGCCCGAAAAA-GCAGGGGGACCCACAA--TGACCGCGCCCGTGAAAGA
EACMV-UG2-Svr  CGGATGGCCGCGCCCGAAAAA-GCAGGTGGACCCACAA--TGACCGCGCCCGTGAAAGA
EACMV-UG2-Mld  CGGATGGCCGCGCCCGAAAAA-GCAGGTGGATCCACAA--TGACCGCGCCCGTGAAAGA
Ca103      CGGATGGCCGCGCCCGAAAAA-GCAGATGGACCCACAGGATCGCCGCGCCCGTGAAAGA
EACMV-CM     CGGATGGCCGCGCCCGAAAAAAGCAGGTGGGCCCCATGA-TAGTCCGCGTCCGCAAAAGA
EACMV-KE     CGGATGGCCGCGCCCGAAAAA-GCAGGTGGACCCACAGGATGGCCGCACTCGTGAAAGA
EACMV-MK     CGGATGGCCGCGCCCGAAAAA-GTAGGTGGACCCATTGGACGGCCGCGTCCGTAAGGA
EACMV-TZ     CGGATGGCCGCGCCCGAAAAA-GTAGGTGGACCCACATGTTGGACGCGCCTGTGAAAGA
***  *****  *****  *

ACMV-NG     AACGTGGTCCCCGCGCAC-TACTCATGTGCGCCAATCATGCTGTAGCGTTAAAGGTTATT
Ca011      AACGTGGTCCCCGCGCAC-TACGTATGTGCGCCAATCATGTTGTAGCGTTAAAGGTTAAGT
Ca024      AACGTGGTCCCCGCGCAC-TACGTATGTGCGCCAATCATGTTGTAGCTTTAAAGGTTATT
ACMV-CM     AACGTGGTCCCCGCGCAC-TACGTATGTGCGCCAATCATGCGGTAGCGTTAAAGGTTAGT
ACMV-UG-Svr  AACGTGGTCCCCGCGCAC-TACGTATGTGCGCCAATCATGTTGGTAGTCTTAAAGGTTATT
ACMV-KE     ATGTGGTCCCCGCGCAC-TACTTATGTGCGCCAATCATGATGTAGCTTTAAAGGTTATGT
ACMV-UG-Mld  ATGTGGTCCCCGCGCACATACGTATGTGCGCCAATCATGTGGAAGCTGTAAAGATTATGT
Ca002      AAGTGGTCCCTGCGCACTTGGTTTTGGTTCGGCCAGTCATATTCACGCGTGAAAGTCTAGAT
EACMV-UG1   AAGTGGTCCCTGCGCACTTGGTTTTGGTTCGGCCAGTCATATTCACGCGTGAAAGTCTAGAT
EACMV-UG1A  AAGTGGTCCCTGCGCACTTGGTTTTGGTTCGGCCAGTCATATTCACGCGTGAAAGTCTAGAT
Ca127      AAGTGGTCCCTGCGCACTTGGTTTTGGTTCGGCCAGTCATATTCACGCGTGAAAGTCTAGAT
Ca068      AAGTGGTCCCTGCGCACTTGGTTTTGGTTCGGCCAGTCATATTCACGCGTGAAAGTCTAGAT
EACMV-UG2-Svr  AAGTGGTCCCTGCGCACTTGGTTTTGGTTCGGCCAGTCATATTCACGCGTGAAATTTCTAGAT
EACMV-UG2-Mld  AAGTGGTCCCTGCGCACTTGGTTTTGGTTCGGCCAGTCATATTCACGCGTGAAAGTCTAGAT
Ca103      AAGTGGTCCCCGCGCACATGTTTTGGTTCGGCCAGTCATATTCACGCGTGAAAGTCTAGAT
EACMV-CM     AAGTGGTCCCCGCGCACGCATGTTTTGGTTCGGCCAATAATAGTTGCGCCTTGAATGCTAGAT
EACMV-KE     AAGTGGTCCCCGCGCACTTGGTTTTGGTTCGGCCAGTCATATTCACGCGTGAAAGTCTAGAT
EACMV-MK     TAAAGTCCCCGCGCACGTGTTGCTGTACGCCAGTCATATTCACGCGTGAAAGTCTAGAT
EACMV-TZ     AAGTGGTCCCCGCGCACTCGTTTTGGTTCGGCCAGTCATATTCACGCGTGAAAGTCTAGAT
*  *  *  *  *  *  *  *  *  *  *  *  *  *  *  *  *  *  *  *  *  *

ACMV-NG     TATTAGTGGTGGACCACTATATAC-TTACAGGCCAAGTC
Ca011      TATTAGTGGTGGGCCACTATATAC-TTGCAGGCCAAGTT
Ca024      TATTAGTGGTGGACCACTATATAC-TTGCAGGCCAAGTT
ACMV-CM     TATTAGTGGTGGGCCACTATATAC-TTACACGCGAAGTT
ACMV-UG-Svr  TATTAGTGGTGGGCCACTATATAC-TTGCAGGCCAAGTT
ACMV-KE     ATTAGTGGTGGGCCACTATATAC-TTGCAGGCCAAGTTG
ACMV-UG-Mld  ATTAGTGGTGGGCCACTATATAC-TTGCAGGCCAAGTTG
Ca002      ATTTGTTGTTTGTCTTTATAGACTTCGTC-GCGAAGTAG
EACMV-UG1   ATTTGTTGTTTGTCTTTATAGACTTCGTC-GCGAAGTAG
EACMV-UG1A  ATTTGTTGTTTGTCTTTATAGACTTCGTC-GCGAAGTAG
Ca127      ATTTGTTGTTTGTCTTTATAGACTTCGTC-GCGAAGTAG
Ca068      ATTTGTTGTTTGTCTTTATAGACTTCGTC-GCGAAGTAG
EACMV-UG2-Svr  ATTTGTTGTTTGTCTTTATAGACTTCGTC-GCGAAGTAG
EACMV-UG2-Mld  ATTTGTTGTTTGTCTTTATAGACTTCGTC-GCGAAGTAG
Ca103      ATTTGTTGTTTGTCTTTATAGACTTCCTC-GCGAAGTAG
EACMV-CM     ATTGAGT-TTTGACTTTAAATACTTCGTC-ACGAAGTAG
EACMV-KE     ATTTGTTGTTTGTCTTTATATACTTCGTC-GCGAAGTAG
EACMV-MK     ATTTGATTAGTGTCTTTATATACTTCGTC-GCGAAGTAG
EACMV-TZ     ATTTGTTGTTTGTCTTTATAGACTTCGTC-GCGAAGTAG
*  *  *  *  *  *  *  *  *  *  *  *  *  *  *  *  *  *  *  *  *  *

```

Figure 25. Alignment of nucleotide sequences from selected DNA-A intergenic regions from ACMV (ACMV-NG, ACMV-KE, Ca011, Ca024, ACMV-CM, ACMV-UG-SVR, Af126800), UgV (Ca002, EACMV-UG1, EACMV-UG1A, Ca127, Ca068, EACMV-UG2-Svr, EACMV-UG2-Mld) and EACMV (Ca103, EACMV-MK, EACMV-KE, EACMV-CM, EACMV-TZ). * depicts identical sequences. Light grey shaded sequences indicate ACMV type iterons and dark grey ones, EACMV type iterons. TATA box is indicated by italics. The invariable nonameric loop structure is bold while //A is the nucleotide number 1 in the circular genome.

When nucleotide sequences of DNA-A intergenic regions were aligned, two sequence clusters were obtained separating ACMV type from EACMV and from EACMV-Ug types. In addition to structural differences of the intergenic regions reflected by various deleted sequence elements in ACMV as well as in EACMV intergenic regions, the most striking difference between the two intergenic regions was the unrelated iterated elements indicated in ACMV by blue and in EACMV by red. Since these cis-acting elements interact with Rep in a sequence specific manner, it is unlikely that ACMV DNA-A Rep recognizes and binds DNA sequences of EACMV. This presents a further argument for separating EACMV and ACMV species.

3.5.5 Comparison of DNA-A ORFs of EACMV-UgV (Ca002) with those of other cassava begomoviruses

The DNA-A genomic component of an EACMV-UgV isolate (Ca002) obtained from Kenya reflects a typical DNA-A component of all UgV isolates and was analysed to demonstrate specific features characterizing a recombinant virus.

The sixth ORF, AC4 that lies within AC1 (Rep) was neither present in EACMV nor in EACMV-Ug and hence it was excluded in the comparative analysis.

The virus EACMV-UG1, is the reference virus isolate first described as the Uganda variant virus (Deng *et al.*, 1997). This virus isolate together with Ca068 and Ca127 had high percentage nt and amino acid sequence identities (>98%) in all the 5 ORFs compared. When these viruses were compared with Ca011, ACMV-Ug-Svr and other ACMV isolates, there was a strikingly higher nt and amino acid sequence similarity among the coat protein genes than that among all the remaining ORFs.

However, when an EACMV-UgV (Ca002) isolate was compared with EACMV isolates (Ca103, EACMV-KE etc.) a reverse situation was revealed. There was a higher sequence similarity in all ORFs across DNA-A than among the coat protein genes.

Table.14. Comparison of nucleotide and deduced amino acid sequences of Ca002 DNA- A and its respective ORFs with those of other begomoviruses from cassava. Sequence identities/similarities >95% are marked in bold for clarity.

| Nucleotide sequences (%) identity | | | Amino acid sequences (%) similarity | | | | |
|-----------------------------------|-------------|-------------|-------------------------------------|-------------|-------------|-------------|--------------|
| Virus isolate | DNA-A | IR-A | Coat protein | Rep AC1 | TrAP AC2 | REn AC3 | Pre-Coat AV2 |
| Ca068 | 98.9 | 98.8 | 99.6 | 98.6 | 97.8 | 99.3 | 99.0 |
| Ca127 | 98.9 | 98.8 | 99.6 | 99.2 | 97.8 | 97.0 | 98.0 |
| Ca103 | 92.4 | 93.9 | 89.5 | 96.7 | 94.1 | 94.0 | 97.0 |
| Ca011 | 73.3 | 64.4 | 91.4 | 69.5 | 65.7 | 71.6 | 56.4 |
| EACMV-UG1 | 98.5 | 95.1 | 100 | 98.6 | 98.5 | 97.8 | 100 |
| EACMV-UG2-Svr | 99.0 | 98.5 | 100 | 98.3 | 98.5 | 99.3 | 100 |
| EACMV-TZ | 91.2 | 91.1 | 89.1 | 96.3 | 91.9 | 91.0 | 95 |
| EACMV-MK | 86.6 | 88.1 | 82.9 | 94.2 | 91.9 | 86.6 | 58.8 |
| EACMV-UG2-Mld | 98.9 | 98.8 | 100 | 98.9 | 98.5 | 99.3 | 100 |
| EACMV-KE | 92.4 | 94.5 | 89.5 | 96.4 | 93.3 | 92.5 | 98.0 |
| EACMV-CM | 84.0 | 88.6 | 88.7 | 91.8 | 57.8 | 63.2 | 93.8 |
| ACMV-UG-Svr | 73.4 | 64.2 | 93.4 | 69.7 | 66.4 | 72.4 | 57.4 |
| ACMV-NG | 74.5 | 63.7 | 92.6 | 69.5 | 67.9 | 70.9 | 57.4 |
| ACMV-KE | 74.6 | 63.8 | 92.2 | 69.5 | 64.9 | 70.9 | 59.6 |
| ACMV-CM | 73.0 | 64.6 | 93.0 | 68.9 | 64.2 | 65.7 | 58.5 |
| SACMV-ZA | 79.1 | 83.6 | 81.7 | 80.4 | 91.9 | 91.0 | 58.8 |
| ACMV-UG-Mld | 73.8 | 64.0 | 93.4 | 69.2 | 65.7 | 70.9 | 56.4 |
| ACMV-KE2 | 73.4 | 63.9 | 92.2 | 69.5 | 64.9 | 70.9 | 59.6 |

3.5.6 Analysis of DNA-B genomic components

When degenerate primers designed from DNA-B sequences were used in a PCR approach to amplify DNA-B genomic sequences, only a limited number of DNA-B sequences were obtained from total DNA preparations of begomovirus infected cassava (Fig.26). A nucleotide sequence alignment of DNA-B fragments of approximately 700 nt spanning from nt position 1600 to about 230 obtained from virus isolates of diverse origins revealed that all sequences retrieved were similar to those of ACMV DNA-B. DNA-B sequences similar to those of EACMV types forming a separate cluster were not found in the cassava plants infected by either virus type.

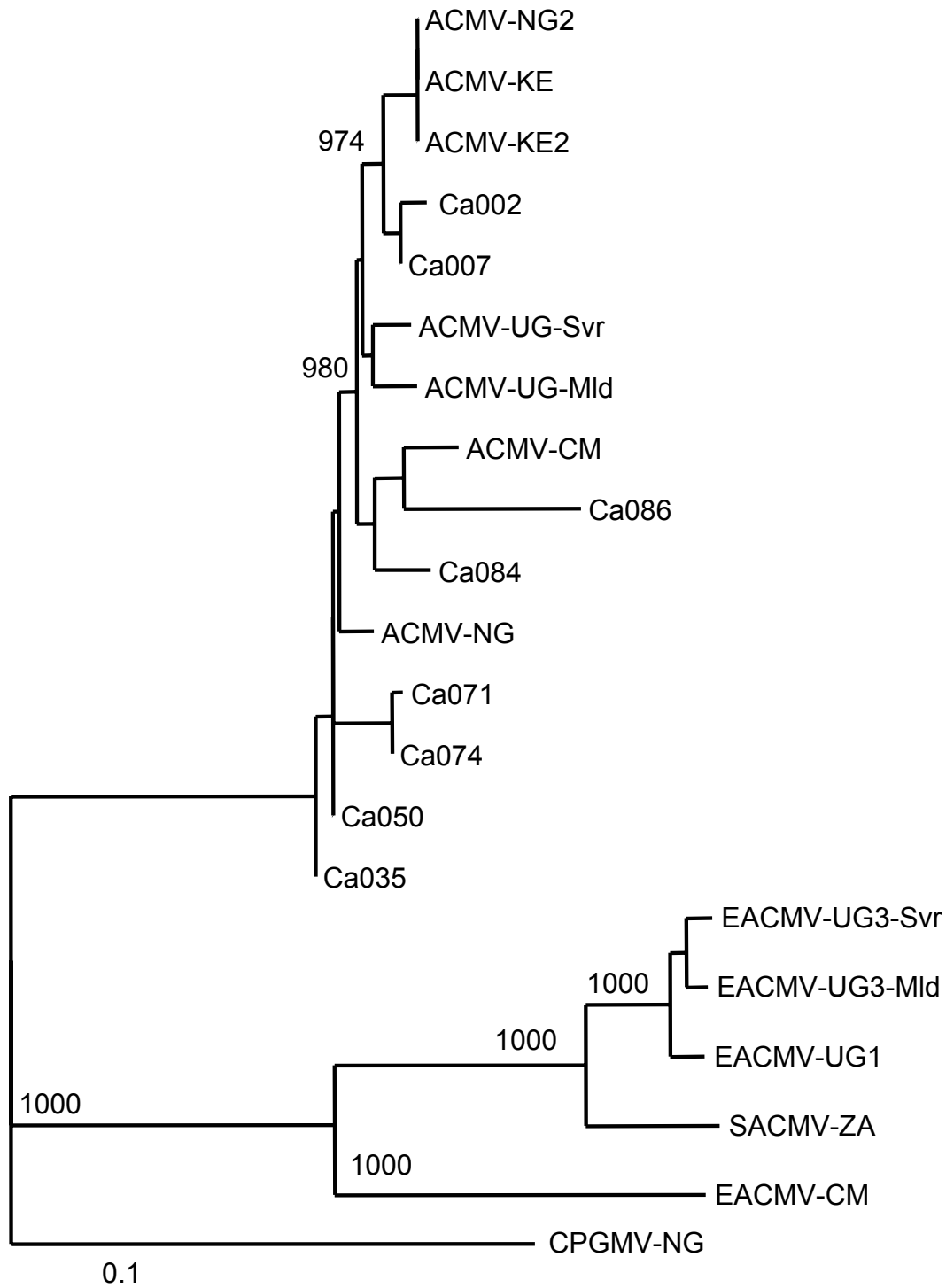

Figure 26. Phylogenetic tree constructed from nucleotide sequence alignments of fragments of DNA-B genomic components of cassava begomoviruses. The PCR fragments aligned cover parts of BC1. CPGMV was used as an out-group.

Full-length DNA-B genomic components were amplified from infected cassava, Ca002, Ca084 and Ca086. A comparison of their DNA-B nucleotide sequences with those from EMBL/GenBank revealed that DNA-B sequences of these viruses were up to 96% identical to those of ACMV type and only about 60% identical to those of EACMV.

Whilst Ca084 represented an ACMV isolate, Ca086 was diagnosed as having a double infection of both UgV and ACMV. Virus isolate Ca002, however, was characterized as having a typical DNA-A genomic component of an EACMV-Ug (Table 14). The amplification of a DNA-B component from an infected cassava is therefore an indication that either the plant had a double infection with a DNA-B from ACMV or confirms the notion that the recombinant EACMV-Ug has a DNA-B, which resembles that of ACMV type. If this is confirmed, then this recombinant virus should also be regarded as a pseudo-recombinant, because its DNA-A replicates a heterologous ACMV DNA-B.

3.6. Infectivity studies of cloned begomovirus genomes

3.6.1 Mechanical inoculation of cloned DNA-A and DNA-B genomic components

These experiments were conducted to verify whether the cloned constructs are capable of causing an infection in *N.benthamiana*, which would confirm their functional activity as a virus or whether heterologous components (DNA-A and DNA-B) of different virus types can effect infection in the plants. The ability of a DNA-A of a Uganda Variant virus to replicate a DNA-B of ACMV or vice versa in *N. benthamiana* and hence form a pseudo-recombinant virus would provide a further insight into the putative components of cassava begomovirus infections.

Stanley (1983) established the infectivity of cloned DNA-A and DNA-B genomic components of cassava latent virus (now ACMV) and demonstrated that both genomic components are required for infectivity. This initial experiments were conducted with full-length genomic components, excised from their respective plasmids and rub inoculated on *N. benthamiana*.

To increase the effectiveness of inoculation, incomplete head-to-tail dimers of the genomic components were constructed and used for inoculation. These DNA-A and DNA-B molecules were mixed and inoculated directly, without prior linearization, to *N. benthamiana*.

Plasmid constructs were inoculated to *N. benthamiana* either as full-length clones excised from plasmid pBSK (Bam HI for DNA-A and NcoI for DNA-B), as linearized plasmid constructs (Hind III for DNA-A and XbaI for DNA-B) and in the case of head-to-tail-dimers, as undigested double stranded DNA.

The results of this investigation are shown in Table 15. Several combinations of DNA-A and DNA-B resulted in infections of *N. benthamiana*, which was verified by TAS-ELISA and by PCR.

Table 15. Infectivity of cloned begomoviral DNA-A and DNA-B in *N. benthamiana*.

| Inoculum | | | Infected plants |
|----------|---------|------------|---------------------|
| DNA-A | DNA-B | Form | infected/inoculated |
| pBSK103 | pBSK002 | Linearised | 1/12 |
| pBSK103 | pBSK002 | Excised | 4/12 |
| pBSK103 | pBSK002 | Undigested | 0/12 |
| pBSK124 | pBSK002 | Linearised | 0/12 |
| pBSK124 | pBSK002 | Excised | 0/12 |
| pBSK124 | pBSK002 | Undigested | 0/12 |
| pBSK106 | pBSK002 | Linearised | 2/12 |
| pBSK106 | pBSK002 | Excised | 2/12 |
| pBSK106 | pBSK002 | Undigested | 0/12 |
| pBSK127 | pBSK002 | Linearised | 0/12 |
| pBSK127 | pBSK002 | Excised | 0/12 |
| pBSK127 | pBSK002 | Undigested | 0/12 |
| pBSK103 | pBSK084 | Linearised | 0/12 |
| pBSK103 | pBSK084 | Excised | 0/12 |
| pBSK103 | pBSK084 | Undigested | 0/12 |
| pBSK124 | pBSK084 | Linearised | 0/12 |
| pBSK124 | pBSK084 | Excised | 0/12 |
| pBSK124 | pBSK084 | Undigested | 0/12 |
| pBSK106 | pBSK084 | Linearised | 1/12 |

Table 15. continued.

| Inoculum | | | Infected plants |
|----------|---------|------------|---------------------|
| DNA-A | DNA-B | Form | infected/inoculated |
| pBSK106 | pBSK084 | Excised | 0/12 |
| pBSK106 | pBSK084 | Undigested | 0/12 |
| pBSK127 | pBSK084 | Linearised | 1/12 |
| pBSK127 | pBSK084 | Excised | 1/12 |
| pBSK127 | pBSK084 | Undigested | 0/12 |
| pBSK011 | pBSK002 | Excised | 4/12 |
| pBSK011 | pBSK002 | Undigested | 8/12 |

In all inoculated cases, symptoms visible in *N.benthamiana* remained very mild and did not resemble infections of *N. benthamiana* with wild type viruses. Infections in *N. benthamiana* generated with heterologous combinations e.g. of EACMV Ca103//ACMV Ca002 or EACMV-UgV Ca127//ACMVCa002 resulted in infections in *N.benthamiana* as was verified by ELISA and PCR. However, when sap of those plants was used for transmission of a putative virus to *N. benthamiana*, mechanical inoculation failed. Since the confirmation of DNA-B in plants inoculated with cloned DNA was not pursued, it is likely that only DNA-A was present in infected plants replicating without DNA-B.

When two ACMV DNA-A and DNA-B genomic components, pBSK011//pBSK002 were used for inoculations, a good rate of infection was reached with inoculation of head-to-tail-incomplete dimers and with inoculation of excised full-length DNA-A and -B to *N. benthamiana*. Symptoms of virus infection in *N.benthamiana* delayed and appeared 15 days after inoculation. Sap of infected plants was fully infectious thus verifying the function of this cloned begomovirus, ACMV.

3.7 Characterization of other viruses from Cassava

3.7.1 Host range and symptomatology

The cassava clone Ca119 obtained from Kwale, Kenya, was further investigated to characterize a virus or viruses suspected to be different from cassava begomoviruses which were a subject of this study.

When sap extracts from Ca0119 were inoculated to a series of test plants, several characteristic local and systemic symptoms were observed (Table 16).

Table 16. Reaction of test plants upon inoculation with sap of cassava clone Ca119.

| Plant species | Symptom | First symptoms visible (days) |
|----------------------------------|------------------------|-------------------------------|
| <i>Chenopodium amaranticolor</i> | - | - |
| <i>C. murale</i> | - | - |
| <i>C. quinoa</i> | - | - |
| <i>Datura metel</i> | Vb, Ld | 6 |
| <i>D. stramonium</i> | LL, Cs, Ns | 7 |
| <i>Gomphrena globosa</i> | - | - |
| <i>Lycopersicum esculentum</i> | - | - |
| <i>Nicotiana benthamiana</i> | Yn, Vb, Sc, St, Py, Pd | 6 |
| <i>N. clevelandii</i> | Yn, Ld, SC, Ss, Pd | 7 |
| <i>N. debneyi</i> | LL, Gs, Ld, St, | 7 |
| <i>N. glutinosa</i> | - | - |
| <i>N. glutinosa</i> 24° | Vb, Sc, Ld, St | 10 |
| <i>N. tabacum</i> 'Samsun 'NN' | - | - |
| <i>Physalis floridana</i> | - | - |
| <i>Solanum demissum</i> | - | - |
| <i>Manihot esculenta</i> | G, Cs, Vb, CSt, M | 9 |

Cs, chlorotic spot; Sc, systemic chlorosis; G, Green spots; Ld, leaf deformation; LL, local lesion; M, leaf mosaic; Ns, necrotic spots; Vb, vein banding; Pd, plant death, St. stunting; CSt, chlorotic streaks; - No symptoms.

In *N. benthamiana*, symptoms of virus infection became visible 6-10 days after inoculation. They consisted of yellow net, vein banding and systemic chlorosis (Fig.27a) followed by yellowing of the entire plant, which could sometimes lead to the death of almost 50% of the test plants (Fig. 27b).



Figure 27. a) *N. benthamiana* showing symptoms of yellow net and vein banding 10 days after sap (extracted from leaves of Ca19) inoculation. b) *N. benthamiana* plants inoculated with sap extracted as in (a) above, die prematurely from infection 3 weeks after inoculation.

When plants were inoculated at later stages (7-10 leaf stage) the number of lethal infections reduced significantly. *N. clevelandii* reacted with yellow net, leaf deformation, systemic chlorosis and plant death if inoculated at very early developmental stages, whereas *D. metel* showed vein banding which was followed by a slight leaf deformation. After the 6th week, the plant recovered completely from

the disease. *D. stramonium* inoculated with infected cassava plant sap, reacted with chlorotic local lesions that turned necrotic as plants aged.

N. glutinosa 24a reacted with vein banding, systemic chlorosis, leaf deformation and stunting (Fig.28).



Figure 28. Reactions of *N. glutinosa* 24a after infection with cassava filamentous viruses.

Back transmission tests to cassava, *Manihot esculenta*, to establish Koch's postulates resulted in symptoms, which did not resemble those of cassava mosaic disease. Inoculated plants reacted with green spots, vein banding, chlorotic streaks on leaves and stem, mottling and a mosaic pattern (Fig. 29).



Figure 29. a) Cassava inoculated with sap from *N. benthamiana* plants showing symptoms of infection with cassava filamentous viruses, b) Severe mosaic and mottling symptoms on cassava infected with EACMV and hitherto undescribed filamentous viruses.

3.7.2 Description of particle morphology

Electron micrographs of crude sap extracted from cassava sample No. 119 revealed typical bisegmented icosahedral geminivirus particles. However, when crude sap of *N.bethamiana* previously inoculated with sap extracted from leaves of cassava sample 119 were examined, long filamentous, flexuous rod-shaped particles resembling potyviruses and/ or carlaviruses were observed (Fig.30).

A thorough EM investigation revealed, in addition to potyvirus-like particles (Fig. 30a), undefined rod shaped particles (Fig. 30c and d) which were suspected to belong to either carlaviruses or, potexviruses, and the shorter particles were suspected to belong to other undescribed viruses, are probably fragments of broken virus particles or, are structures produced by host cells. The pin wheel structures (Fig. 30b), however, occasionally found in sap preparations strongly indicated that a member of the *potyviridae* is present in the cassava material.

In *N.glutinosa* 24a only carlavirus-like particles were observed (Fig.31) and potyvirus-like particles were never demonstrated in this host. This provides an indication, that a second virus type might be present in these cassava plants.

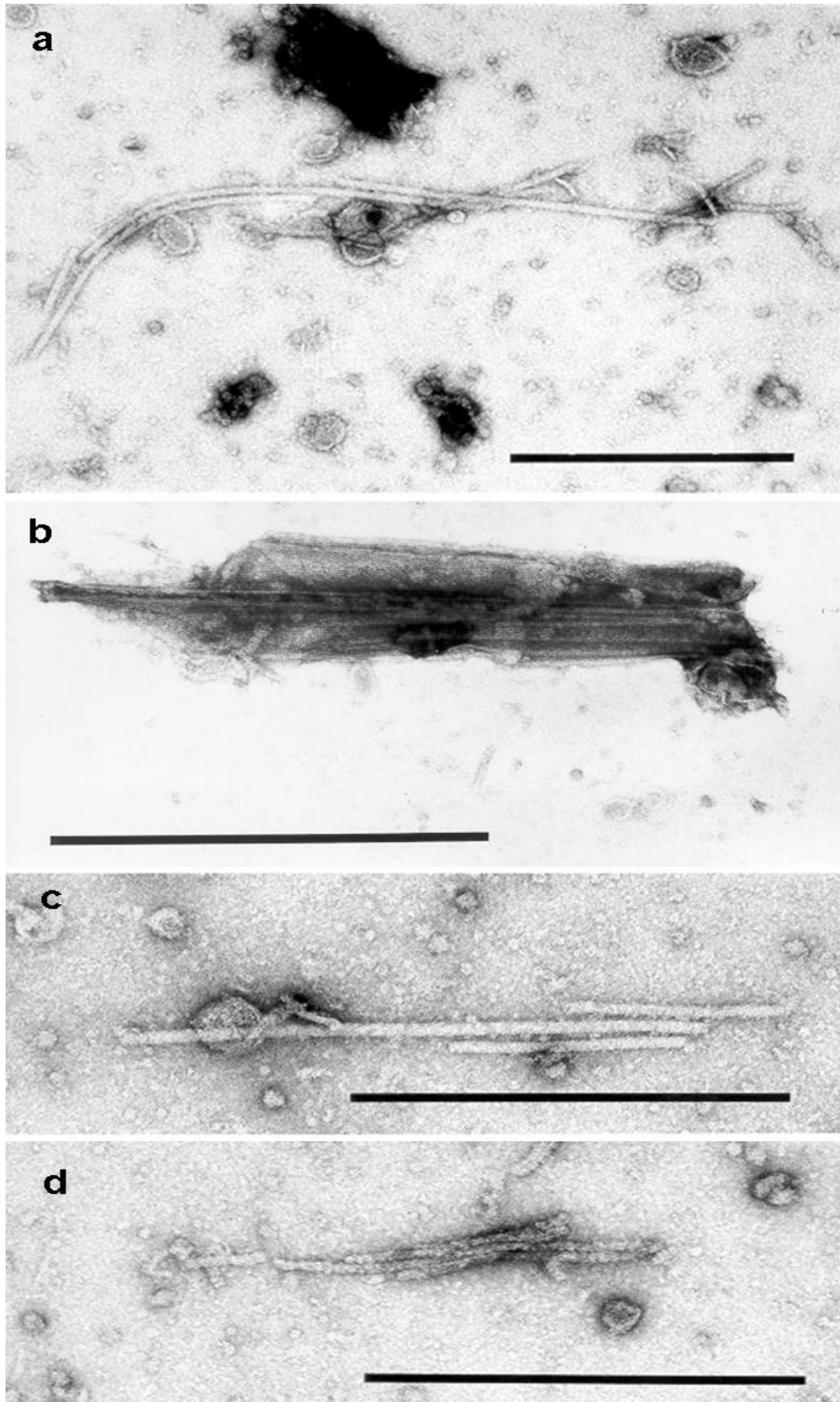

Figure 30. Electron micrograph showing negatively stained preparations (from *N. benthamiana*) of potyvirus-like particles a), with pin wheel structures b) and undefined rod-shaped structures c) and d). Bar represents 500 nm.

3.7.3 Virus propagation and purification trials

All attempts to obtain pure preparations of the virus were unsuccessful, besides, virus yields obtained by purifying either from *N. benthamiana* or from *N. glutinosa* were very low. Electron micrographs of virus preparations from *N. glutinosa* revealed virus-like particles resembling carlaviruses (Fig. 31).

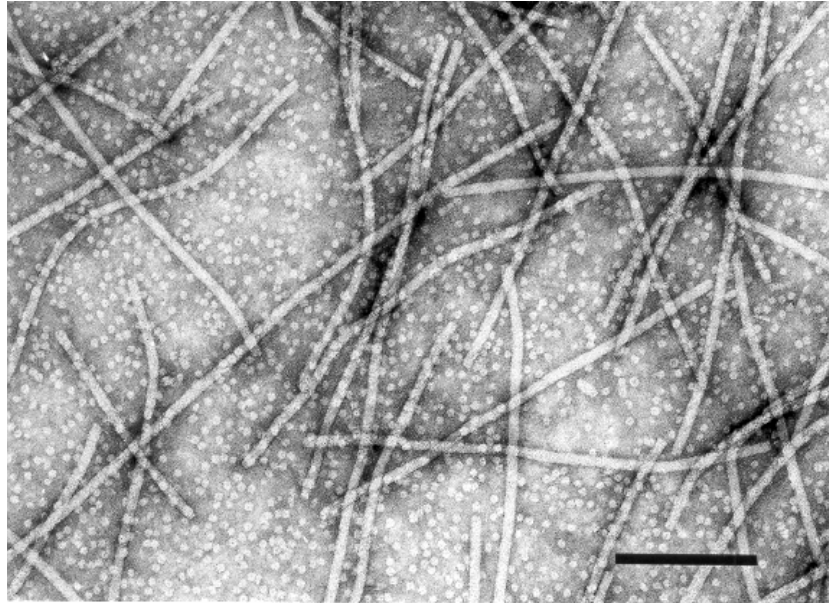

Figure 31. Electron micrograph of a partially purified virus preparation from *N. glutinosa* 24a showing negatively stained (1% UAc) carlavirus-like particles. Globular structures represent contaminations of the preparation with phyto-ferritin. Bar represents 200 nm.

3.7.4 Determining capsid proteins of putative filamentous viruses of cassava

SDS-PAGE of crude sap of virus infected plants and purified virus preparations, revealed two peptide bands, a 38 kDa and a 34 kDa peptide in addition to the 54 kDa Ribulose biphosphate carboxylase, RuBisCo, protein present in the semi-purified preparation (Fig. 32 lane 6) and removed in the second purification attempt (Fig. 32 lane 7). It was not clear whether the 34 kDa peptide reflects an artefact which occurred during the purification process or it resulted from partial proteolysis of the viral coat protein. In some virus purifications, (not shown) an additional virus band of about 28 kDa was observed.

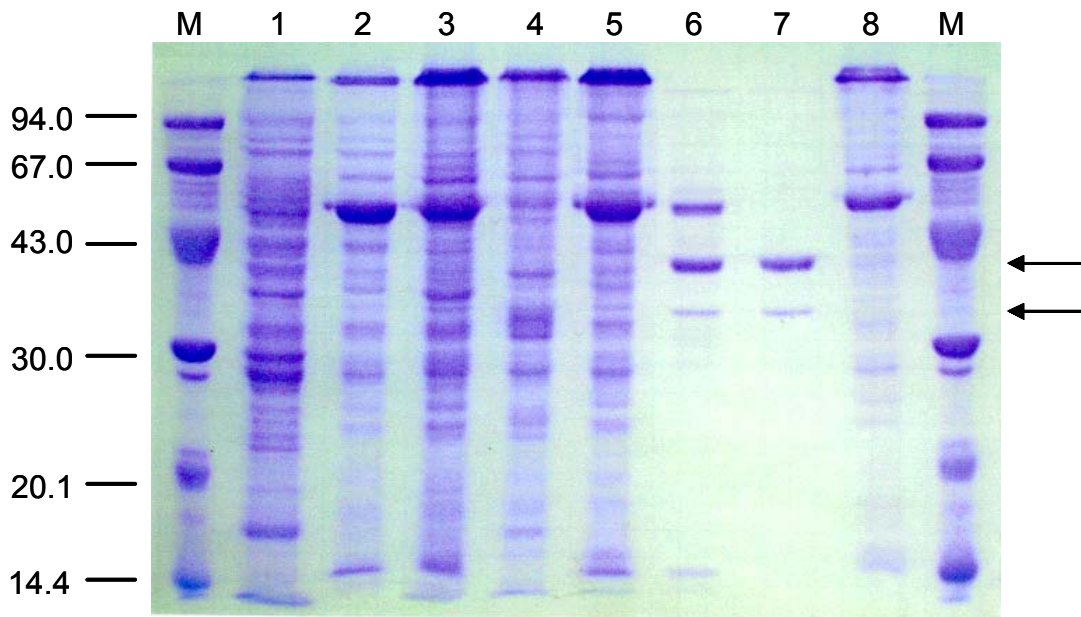

Figure 32. SDS-PAGE analysis of protein preparations of plants infected with Ca119 virus. lanes 1 = *G. globosa*, 2 = *N. benthamiana*, 3 = *N. clevelandii*, 4 = *N. debneyi*, 5 = *N. glutinosa* 24a, 8 = non-infected *N. debneyi*, lanes 6 and 7 = purified virus preparations, M = Marker. M_r (kDa).

Since it was not possible to reach sufficient amounts of purified virus preparations from neither the carla-like virus isolated on *N. glutinosa* nor from *N. benthamiana*, where more potyvirus-like particles were found, the identity of the virus/viruses remains an enigma.

However, with the Koch's postulates verified the virus(es) should be considered true pathogens of cassava.

4.0 DISCUSSION

Until now, cassava mosaic disease (CMD) is the most important constraint to cassava production in Africa. It is caused by whitefly transmitted viruses belonging to the taxonomic family *Geminiviridae* and to the genus *Begomovirus*.

Several virus species and variants infecting cassava in Africa have been described. ACMV occurs predominantly in Western, Central, and Southern Africa while EACMV occurs in East African countries of Kenya, Tanzania, Malawi, Madagascar, Zambia, Zimbabwe and sporadically in West African countries of Cameroon, Nigeria and Guinea. The outbreak of a severe form of CMD, first reported from Uganda towards the end of the 1980s, has devastated cassava fields and caused serious food shortages. The disease spread rapidly in all directions into the neighbouring countries in East and Central Africa. Molecular studies have provided evidence that UgV is responsible for increased severity and that it arose by way of intraspecies recombination between ACMV and EACMV (Zhou *et al.*, 1997; Deng *et al.*, 1997).

This study was initiated because of the devastating effects of the new form of CMD whose aetiology had not been resolved at the onset of this investigation. Many open questions and speculations pertaining to the composition of the disease aetiology, the probable involvement of hitherto un-described viruses and whether or not synergistic effects of viruses in mixed infections contributed to the serious decline in cassava yields, prevailed in discussions on how effectively and precisely to respond to the challenges posed by this new disease.

Transmission and symptomatology. Although biological properties of plant viruses such as symptomatology, host range and mode of transmission are considered in general terms as unreliable indicators of virus identity (Hamilton *et al.*, 1981), they are however, still widely used as vital means of virus classification especially when distinguishing between virus strains (Hollings and Brunt, 1981a; Shukla *et al.*, 1988). Moreover, information on virus host range and the means by which it is transmitted are essential prerequisite for developing appropriate virus control measures (Mathews, 1991).

In order to inoculate viruses obtained from cassava to test plants, three methods of transmission used in this study (sap inoculation, biolistic inoculation and grafting) resulted in successful infection of the test plants. Nevertheless, cassava begomoviruses varied in their transmissibility. For instance ACMV was transmitted without difficulty to *N. benthamiana* (over 95%) by sap inoculation. However, EACMV and UgV were difficult to transmit to these test plants (below 10%), besides, some UgV isolates from Kenya and Uganda could not be transmitted to *N. benthamiana* by this method. When sap obtained from plants having a mixed infection with either ACMV/EACMV or ACMV/UgV, was rubbed onto test plants, only ACMV was transmitted. This attests the high transmission efficiency of ACMV by this method when compared to either EACMV or UgV. Suffice it to say that all the three begomoviruses could not be transmitted back to cassava by sap inoculation. These findings agree with those of Berrie *et al.* (1997) whose attempts to transmit SACMV back from *N. benthamiana* to cassava by sap inoculation were unsuccessful. The results obtained contrast those obtained by Bock *et al.* (1978), who by determining the experimental host range of ACMV-KE, reported that the virus was readily transmissible to several solanaceous plants, including species of *Nicotiana* and *Datura*. However a successful back transmission to cassava was difficult and only feasible with very susceptible varieties.

Cassava and *N. benthamiana* plants were successfully infected with all the three begomoviruses when inoculated by biolistic means using total DNA extracted from virus-infected plants. DNA extracted from doubly infected plants when inoculated to test plants resulted in mixed infections with the viruses in question. This double transmission was not possible with sap inoculation. This is the first report on the use of total DNA extracted from begomovirus-infected plants to infect cassava with cassava begomoviruses. Briddon *et al.* (1998) successfully inoculated genomic clones of ACMV-NG using a hand held biolistic device. This was the first demonstration that cloned full-length DNA components of a geminivirus could infect cassava. Unfortunately, attempts to conduct whitefly transmission experiments have remained very limited among scientists, due to several constraints such as the feeding preferences of the vector and biotype incompatibility. These problems can be avoided by the use of the biolistic method to infect cassava with the viruses.

Plant breeders and researchers can conveniently use the method to inoculate cassava plants with target virus without the need for using whitefly inoculations.

Graft inoculation was quicker and more efficient than the former two methods. All the three begomoviruses were transmitted to healthy cassava plants by this method and resulted in virus infection without difficulty. Although grafting was efficient, it cannot be recommended for routine screening due to the fact that when a scion is taken from a plant infected with more than one causal agent, such as viruses, bacteria, nematodes and/ or fungi, all would be transmitted to the test plant.

N. benthamiana plants when infected with cassava begomoviruses displayed symptoms of leaf curling, chlorosis and yellow blotching. The latter characteristic was not observed on plants inoculated and infected with either EACMV or UgV. The most significant and striking difference in symptomatology among begomoviruses on *N. benthamiana* was that between ACMV-KE and ACMV-NG. The reasons for this complete blotching of leaves in ACMV-KE were however not clear.

Distribution of cassava begomoviruses in Kenya. The results of the virus surveys in Kenya demonstrate a marked increase in prevalence, incidence and severity of CMD especially in the Western and Nyanza provinces. A disease incidence of up to 100% was observed in many fields where severely affected plants (score 4.5) prevailed. This epidemic situation is similar to that described by Otim-Nape *et al.* (1996) in Uganda, and by Cours (1951) in Madagascar, and to those of Gibson (1996) and Legg *et al.* (1999b) who found incidence of CMD of more than 80% in most fields near the Kenya/Uganda border. These findings contrast sharply with those of CMD surveys conducted in 1993 at 13 locations in Western Kenya (Legg *et al.*, 1999), which gave an account of disease incidence in the area to be about 20%.

The increase in incidence and severity of CMD and the general crop failure noticed in the districts of Busia, Teso, Siaya, Kakamega, Bungoma and some parts of Suba district can be attributed to UgV infections, unavailability of virus-free planting material and the apparent ignorance of farmers about CMD. Molecular (PCR) and serological (ELISA) analysis of samples from the surveyed region revealed that most samples (52.2%) from Teso, Busia and Siaya districts were positive for UgV and with only a few samples (17.4%) having a mixed infection with both ACMV and

UgV. These results prove that UgV has displaced ACMV as the most prevalent virus type in this area. However, the results contrast sharply with the speculations on synergistic effects of mixed (UgV/ ACMV or EACMV/ ACMV) infections in cassava (Harrison *et al.*, 1997; Fondong *et al.*, 2000; Pita *et al.*, 2001) as being responsible for the increased CMD severity.

This is the first report on the presence of UgV in Western Kenya and it confirms reports of other workers (Otim-Nape *et al.*, 1997; Gibson, 1996 and Legg and Okoa-Okuja, 1999) which based their observations of increased incidence and severity of CMD in the region. The questions that arise from the disease analyses are: how did UgV displace ACMV and why did it spread so quickly?

Several arguments have been put forward to answer the above questions but experimental evidence to that effect is lacking. First, it has been speculated that there is a preferential transmission of UgV by whiteflies. Work done by Briddon *et al.*, (1990), Höfer *et al.*, (1997) and Noris *et al.*, (1998) showed that geminivirus coat protein is responsible for vector transmission because exchanging amino acids in key positions of the coat protein completely abolished or significantly reduced the efficiency of whitefly transmission. The recombination events in the UgV coat protein gene do not pinpoint the amino acid positions specified for TYLCV transmission (Noris *et al.*, 1998). However, since the interaction of the whitefly receptors with the virus capsid appears not to be determined by a certain motif in the protein (like the DAG involved in aphid transmission of potyviruses) but rather by the composition of a domain, an altered capsid protein structure (through recombination) might result in preferred virus uptake by or, translocation in the whitefly vector. However, the obvious problems of biotype incompatibility and the feeding preferences of *B.tabaci* render vector/virus transmission studies in cassava almost impossible (Abdullahi, 2001). In addition, the structure of the *Maize streak virus* geminate particle (Zhang *et al.*, 2001) has recently been described, but the experimental evidence for the alteration of a structural feature of the coat protein caused by the recombination event is lacking.

Another possibility for a selective transmission of UgV from mixed virus infected plants can be highly attributed to the recovery and reversion phenomenon (Pacumbala, 1985; Fauquet *et al.*, 1988; Rossel *et al.*, 1988) observed in cassava

plants infected with ACMV. These workers discovered that some cassava varieties, have the ability to localise the distribution of cassava begomoviruses so that whole branches or individual shoots may develop free of any detectable virus. This phenomenon was rarely observed in UgV infected plants, which remained symptomatic almost throughout the year. Moreover, two plants obtained from the Democratic Republic of the Congo having a mixed virus infection between UgV and ACMV were evaluated for their viral status at 6-month intervals. After 18 months, ACMV disappeared beyond detection leaving only UgV present. In a field situation with mixed ACMV/UgV infections, a down regulation or, uneven distribution of ACMV through recovery and reversion, would leave only UgV to be spread by the whiteflies. Consequently this virus then becomes the predominant virus after displacing ACMV in the field. The absence of whiteflies in the region during the survey can be attributed to a high amount of rainfall that was pounding the area at the time. This observation is supported by work done by Golding (1936) in Nigeria in which he observed a reduction in the number of adult whiteflies due to mechanical destruction of the insects by the rain showers. Furthermore, Fishpool *et al.* (1995) showed rainfall to be negatively correlated to population size of the whiteflies and attributed this to a reduction in oviposition. These results contrast sharply with earlier findings in the same area (Gibson, 1996; Legg *et al.*, 1999).

Interestingly, mixed infections between EACMV and ACMV were rarely observed. The detection of EACMV in samples from the two provinces in Kenya confirms earlier work done by Ogbe *et al.*, (1996, 1997) who detected the virus in a sample collected near Kisii in Nyanza province. In this study, EACMV was detected in four samples from the region, but the percentage of samples with the virus was very low when compared to those with UgV and/ or ACMV. This clearly shows that despite earlier reports (Swanson and Harrison, 1993), the geographic distribution of EACMV and ACMV overlaps. Whilst the presence of EACMV alone in the Coastal areas of Kenya seems to present only little problems to cassava production, ACMV and UgV threaten the survival of the crop in the Western parts of the country, where ACMV had been the only virus previously known. These findings make Western and Nyanza provinces the only known locations where the three cassava viruses (ACMV, EACMV and UgV) co-exist. In retrospect, it is highly likely that a recombination in the coat protein gene between ACMV and EACMV that gave rise

to UgV took place in this area and not in Uganda where the virus was first detected. This argument is further supported by the fact that EACMV has never been found in Uganda (Harrison *et al.*, 1997; Ogbe *et al.*, 1996).

Distribution of cassava begomoviruses in Africa. Studies on the distribution of cassava begomoviruses in Africa showed that ACMV occurred everywhere except on the Kenyan coast while UgV was detected in samples from an area stretching from Western Kenya and Uganda to the Bas-Congo region of the DRC. DRC is currently regarded as the epicentre of the epidemic with frontier areas. At the virus fronts a large number of samples had mixed infection with both ACMV and UgV and a few plants were infected with ACMV alone but rarely with only UgV, which is an indication of a recent invasion of the area by the UgV. This mixed virus situation seems transient and due to the recovery phenomenon explained above, UgV may remain the single dominant virus in infected cassava after the previously double infected plants recover from ACMV. This was already evident in Eastern provinces of the DRC where UgV invasions took place much earlier and the virus has now displaced ACMV infections in cassava.

This is the first report on the occurrence of UgV in the Democratic Republic of the Congo. It is most likely that the virus has also already spread to neighbouring countries such as Angola and Congo Brazaville where no cassava samples were collected. Since the first association of UgV as the causal agent of the severe form of CMD in Uganda (Zhou *et al.*, 1997), the disease has been reported to be spreading at a rate of 20-30 km/year in all directions from the place where it was first diagnosed (Otim-Nape *et al.*, 1996). The rapid virus movement is fuelled by human activities such as transport of infected cassava cuttings over long distances like that witnessed in the DRC due to rapid displacement of people by war. If the status quo is maintained, UgV is more likely to replace ACMV and become the most predominant virus in Africa in a couple of years. In summary, UgV spread in the field is characterized by the invasion by the recombinant virus of areas where ACMV already exists, then mixed virus infections of ACMV and UgV are transiently formed, which finally transforms into only UgV infections.

In this study begomoviruses ACMV, EACMV and UgV were only rarely found outside their traditional areas of distribution. EACMV was distributed along the coast of the continent including Guinea in West Africa, where it was found in only one sample. However, contrary to earlier reports (Legg, 1999), EACMV was not detected in samples from Togo and Madagascar. The absence of EACMV in these samples could have been due to the fact that samples were not representative of all cassava growing areas of these countries. A thorough diagnostic survey such as that done in Kenya is recommended in order to make a profound statement on the presence of this virus in these countries. Although SACMV has been reported occurring only in South Africa (Rey and Thompson, 1998), it is highly probable that the virus exists in neighbouring countries as well. As with EACMV, a thorough survey using improved diagnostic tools is needed to determine the distribution of this virus in Africa.

Occurrence of other virus pathogens in cassava. Clear virus infections were obtained when sap extracted from a cassava plant showing abnormal symptoms not similar to those caused by CMD was rub-inoculated to *N. benthamiana* and to cassava. Whenever sap extracted from cassava plants infected with a begomovirus in addition to the filamentous viruses was used to inoculate healthy *N. benthamiana* plants, only filamentous viruses and not the begomoviruses were transmitted. Attempts to induce a double infection of the two viruses using sap inoculation technique in *N. benthamiana* were unsuccessful. This shows that these viruses have higher transmission efficiencies than begomoviruses. The viruses inflicted heavy symptoms on *N. benthamiana* sometimes resulting in plant death if the plants were inoculated at a 2-3 leaf stage and in cassava symptoms marked by chlorotic spots, irregular yellow vein banding appeared on young leaves 2-3 weeks after sap inoculation, and as the leaves aged, the chlorotic spots enlarged. This contrasts sharply with the findings of Bock (1994c) on *Cassava brown streak virus* (CBSV) in which symptoms were not that severe and were only found on old leaves of cassava plants. Despite repeated attempts, Bock failed to transmit the virus back to cassava by sap inoculation. This implies that either Bock was working with a different virus or that the cassava samples used in this study were infected with a virus that could be transmitted back to cassava in addition to CBSV. An additional argument against single infection of cassava plants with only CBSV, is Bock's

description of symptoms, which restricts symptoms to older cassava leaves and not on the young leaves as observed in this study.

The length of the viruses could not be measured due to low virus concentration in crude sap while in purified virus preparations, the integrity of the virions could no longer be guaranteed after purification (Lesemann, pers. comm.). Nevertheless, based on the enlarged pictures of the few particles, particle length was estimated to be about 200 nm for the shortest, 500 nm for the medium flexuous, 650 nm for long and slightly flexuous, and about 750 nm for the longest flexuous rods. Viruses of 650 nm in length were reported to be associated with cassava at the coastal region of Kenya (Bock, 1994c) but the existence of filamentous viruses of shorter lengths has never been reported in this area. The presence of pinwheels and flexuous rod-shaped particles was an indication that a potyvirus is associated with this infection. On the other hand the presence of slightly flexuous rod-shaped particles equivalent in length (650 nm) to potyviruses imply a possible association of a carlavirus with the infection. Surprisingly however, more than 50 antisera used in ISEM for potyvirus identification failed to decorate the particles (Lesemann pers. comm.). Furthermore, attempts to amplify potyvirus sequences using an RT-PCR approach with degenerate potyvirus-genus specific primers (Langeveld *et al.*, 1991) were not successful. Thus, the identity of the virus or viruses in these cassava plants still remains elusive. Nevertheless, the results of back transmission experiments clearly demonstrated that these viruses are true pathogens of cassava.

Based on SDS analysis of crude sap and partially purified virus preparation, the capsid-protein sizes of 42- and 38-kDa were observed in all preparations while a 28-kDa band was observed in a few of them. The size of CPs of potexviruses has been reported to be in the range 21 – 27-kDa (Xu *et al.*, 1994), implying that the 28-kDa band observed in this study belongs to a virus either in the potexvirus group or to viruses that were described as undefined structures. The other possibility could be that either the 38- or the 42-kDa band was degraded by proteolytic enzymes of plant or microbial origin (Shukla and Ward, 1988) reducing its size to 28-kDa. Comparisons of the protein bands separated in the SDS-PAGE of partially purified virus preparations vs. crude sap of virus-infected and non-infected plants revealed that the 54 kDa band is most likely to be of host plant origin, while the 42-, 38- and

28-kDa bands are of viral origin. This however, could not be verified by Western-blot analysis due to lack of virus-specific antisera.

The scope of this work did not allow further characterization of these filamentous viruses, however, future work may concentrate on purification, antibody production and genome analysis. This study has provided evidence that in Africa not only begomoviruses cause serious diseases of cassava but also filamentous viruses. Despite their limited distribution, they can reach local significance and can most probably be as serious as begomoviruses.

Serological diagnosis of begomoviruses in cassava. Monoclonal antibodies to geminiviruses have already been prepared (Thomas *et al.*, 1986) and in this work a detailed study on the antigenic relationships between different begomoviruses and isolates is provided. In DAS-ELISA, ACMV-KE was indistinguishable from ACMV-NG, EACMV and UgV as all virus species and isolates reacted strongly in DAS-ELISA with the polyclonal antibody raised against ACMV-NG. This can be explained by earlier studies on the nucleotide sequences of coat protein genes (Stanley and Gray, 1983; Hong *et al.*, 1993 and Zhou *et al.*, 1997), which were highly conserved in the different viruses. The strength of this relationship complicates the identification of individual viruses by DAS-ELISA. In contrast, using TAS-ELISA, each virus showed a distinct pattern of reactivity with a panel of MAbs raised against TYLCV. In this study, it was found that the reactions of UgV with the MAbs were similar to that of ACMV-NG. Furthermore the MAbs grouped the viruses into three groups, the first one included ACMV-NG, UgV and to a less extent ACMV-KE, the second comprised EACMV and the third, only ICMV. The three antigenic groups are to a large extent formed by viruses, which are geographically isolated (Swanson and Harrison, 1993) with EACMV and ACMV from Africa while ICMV as a separate virus species from India. These findings agree with earlier work (Harrison *et al.*, 1997; Harrison and Robinson 1988; Natesh *et al.*, 1996; Swanson *et al.*, 1992) that the coat protein genes of begomoviruses from the same geographical region are highly identical and hence antigenically indistinguishable. The fact that MAbs raised against a TYLCV isolate were used to detect cassava begomoviruses confirms earlier works (Cohen *et al.*, 1983; Sequeira and Harrison, 1982; Stein *et al.*, 1983) on the determination of serological relationships among *Squash leaf curl virus*

(SqLVCV), ACMV and *Tomato golden mosaic virus* (TGMV). The nature of these relationships has since been explored in more detail by tests with MAbs (Thomas *et al.* 1986; Muniyapa *et al.*, 1991; Macintosh *et al.*, 1992) and summarized by Harrison and Robinson (1999).

Several MAbs proved useful for routine virus detection and identification. For example MAbs 1C1 and 4D12 detected all African cassava begomoviruses. These MAbs can be helpful in ecological studies particularly when searching for reservoir hosts for these begomoviruses. Where there is need to discriminate between the first group (ACMV-KE/ACMV-NG and UgV) and the second group (EACMV), the tests should be done with one of the MAbs 6A6, 5B6, 2F1 or 4F10. For instance, a combination of 1C1 and either 6A6 or 4F10 gives excellent results in differentiating EACMV from the other cassava begomoviruses. Furthermore, tests using one of the MAbs, 5D8, 2F11, 4F11 or 1H2 in combination with 1C1 or 5B6 will discriminate between ACMV-KE and ACMV-NG. MAb 6E9 can be used to differentiate between EACMV and UgV on one hand and ACMV-KE/ACMV-NG on the other whereas MAb 4G7 can be used to specifically detect only ICMV.

All attempts to raise specific antibodies against EACMV or UgV were unsuccessful. Even expressed recombinant protein used in the immunization of mice failed to produce specific MAbs. This is most probably explained by the fact that epitopes in geminivirus coat proteins are discontinuous (Swanson, 1992) and that a specific epitope is not displayed by an amino acid sequence but rather, by structural features of the protein. Interestingly, the stringent screening process conducted in selection of putative differential MAbs allowed MAbs that specifically recognized ACMV isolates, although a recombinant EACMV coat protein was used as immunogen. Using a combination of these MAbs and those raised against TYLVCV, it was possible to discriminate the different cassava begomoviruses and virus variants. Despite the excellent results obtained using the series of MAbs, mixed virus infections could not be satisfactorily resolved due to lack of MAbs that specifically recognize either only EACMV or only UgV.

For rapid determination of virus presence in cassava a TBIA protocol was used. Using polyclonal antisera, DAS-ELISA detected all cassava begomoviruses regardless of origin and host whereas using MAbs, TAS-ELISA allowed for

differentiation of individual viruses, virus strains and/ or variants. TBIA using either polyclonal antibodies or MAbs on the other hand allowed for the distribution of the virus within the plant or plant tissue to be studied in addition to differentiation of the viruses. TBIA was easy to use except when the plant tissue was difficult to manipulate such as very small leaves and petioles or when samples were frozen. Virus was detected in stems, petioles and leaves of cassava and *N. benthamiana*. For samples in which not much virus is present, TBIA appears to be accurate, consistent and therefore more reliable than ELISA. The samples that tested negative with TBIA could not test positive even with PCR implying that the virus was actually absent. This was mainly in old plant parts of cassava an indication that the virus either moves to young parts of the plant as the plant ages or it is destroyed with time. In view of the fact that more virus was detected in young plant tissues than in old ones, we recommend that for diagnostic purposes, only young symptomatic tissues be used whenever diagnosis work is to be done. Furthermore, since there was more begomovirus in *N. benthamiana* than in cassava, the plant is a suitable propagation host for virus purification.

This technique can be used as a diagnostic tool in detection of cassava viruses provided the right MAbs are available. This is demonstrated by its easiness to use, sensitivity and rapidity. Samples can be blotted in the field during field surveys and mailed to the laboratory in envelopes for evaluation thus saving on the cost of transport.

Detection and differentiation of cassava begomoviruses using PCR. Although PCR procedures are more complex than those of ELISA, they could differentiate viruses even in a mixed infection. The primer combinations used for differentiation of viruses in cassava have been altered and amended several times to provide reliable and robust PCR results. Since DNA-B genomic components are more diverse among different viruses and even virus isolates, primers designed from its sequences are more specific than those designed from DNA-A genomic components. DNA-A sequences were used to design primers specific for both homologous and sometimes heterologous viruses within the genus. Designing specific primers for UgV was particularly problematic, since only the recombinant segment in the coat protein qualified as a primer target region. However the primer

sequences proposed in this study, for differential amplification and subsequent identification of the virus types in question proved robust and reliable in many PCR reactions with cassava samples from diverse origins. For a successful PCR assay of cassava begomoviruses, sampling of the right plant tissues and subsequent DNA extraction is very important. Among the methods used, a plant DNA mini preparation method (Dellaporta *et al.*, 1983) proved extremely versatile and useful.

With the serological and molecular diagnostic methods of cassava begomoviruses developed in this study, it is now possible to reliably detect and discriminate these viruses. The different degrees of infrastructure required to perform these type of tests, determine whether the assays can be conducted on site, or in sophisticated laboratories. The use of TAS-ELISA, which was evaluated during the field surveys in Kenya, already provides very good indications on the putative viruses present in a respective sample or in the field. This method can be used for virus indexing in the production of virus free planting material.

Sequence analysis of begomoviruses infecting cassava. Complete nucleotide (nt) sequence analysis of DNA-A components of different cassava begomoviruses revealed four virus types, ACMV-NG, ACMV-KE, UgV and EACMV being predominantly present in cassava in Africa. It became increasingly clear that the UgV isolates are strains of EACMV. When attempts were made to retrieve DNA-B genomic components from UgV-infected cassava, only sequences resembling those of ACMV DNA-B were obtained. In spite of the obvious divergence in the intergenic regions among these virus species, a hypothesis was followed which should permit the Rep located on DNA-A to replicate a heterologous DNA-B. This was experimentally studied with full-length clones constructed by PCR using a proof-reading polymerase. However, upon inoculation of *N. benthamiana* plants with cloned virus components, a few clones of heterologous DNA-A and DNA-B combinations caused virus infections although symptoms in test plants were attenuated. In addition, positive ELISA and PCR results confirming virus infectivity could not be sustained. This phenomenon can be explained by a similar observation made by Klinkenberg *et al.*, (1989) who introduced cloned ACMV mutants into *N. benthamiana* by agro-inoculation. In the absence of DNA-B, ACMV coat protein deletion mutants independently replicated and maintained their size in

actively dividing callus tissue. In the case of this study, it can be argued that DNA-A was successfully introduced into *N. benthamiana*, replicated and was passively moved with the actively dividing cells of the newly formed leaves. The failure to induce symptoms in *N. benthamiana* can be attributed to a missing replication of DNA-B which is largely responsible for symptom expression. In the homologous case, as with DNA-A from Ca011 and DNA-B from Ca002, which are both genomic components of ACMV, a successful infection of *N. benthamiana* was obtained and all vital viral characteristics such as symptom expression, formation of geminate particles, presence of DNA-A and DNA-B genomic components in systemically infected plants, were verified. This infectious virus clone can now be used for further studies of disease phenotypes in cassava.

UgV is a distinct strain of EACMV. As shown with differential PCR tests, TAS-ELISA and sequences of viral genomes or portions thereof, the Uganda variant virus is a recombinant virus with predominantly an EACMV DNA-A genomic component that possesses a coat protein gene chimera formed by an insertion of an ACMV segment in the core region. Sequence analysis of coat protein genes of UgV isolates from different regions further revealed that the recombinant coat protein gene is highly conserved among them. This further substantiates findings of Pita *et al.* (2001), which were based on analysis of a limited number of virus isolates obtained from one region (Uganda).

Analysis of the DNA-A genomic component of UgV provides an unequivocal argument for the taxonomic position of this virus as a strain of EACMV. However, this virus isolate apparently has significant advantages over its parents due to its rampant spread and competitiveness.

LIST OF REFERENCES

- Abdullahi, I., 2001.** Diversity of whitefly (*Bemisia tabaci* Genn.) populations in relation to *African cassava mosaic virus* disease development. Ph.D. thesis, Univeristy of Ibadan, Nigeria, 249pp.
- Antignus, Y., and Cohen, S., 1994.** Complete nucleotide sequence of an infectious clone of a mild isolate of tomato yellow leaf curl virus (TYLCV). *Phytopathology* **84**, 707-712.
- Argüello-Astorga, G., Herrera-Estrella, L., and Rivera-Bustamente, R., 1994.** Experimental and theoretical definition of geminivirus origin of replication. *Plant Mol. Biol.* **26**, 553-556.
- Berrie, L.C., Plamer, K.E., Rybicki, E.P., Hyadat, S.H., Maxwell, D.P., and Rey, M.E.C., 1997.** A new isolate of African cassava mosaic virus in South Africa. . *African Journal of Root and Tuber Crops* **2**, 49-52.
- Berrie, L.C., Rybicki, E.P., and Rey, M.E.C., 2001.** Complete nucleotide sequence and host range of *South African cassava mosaic virus*: further evidence of recombination amongst begomoviruses. *J. Gen. Virol.* **82**, 53-58.
- Bethke, J.J., Paine, T.D., and Nuessly, G.S., 1991.** Comparative biology morphometrics and development of two populations of *Bemisia tabaci* (Homoptera Aleyrodidae) on cotton and poinsettia. *Ann. Entonol. Soc. America* **84**, 407-411.
- Birnboim, H.C., and Doly, J., 1979.** A rapid alkaline extraction procedure for screening recombinant plasmid DNA. *Nucleic Acids Research* **7**, 1513-1523.
- Bock, K.R.,1987.** Some aspects of the epidemiology of African cassava mosaic virus in coastal districts of Kenya. In: *Proceedings of an international seminar on African Cassava Mosaic Disease and its control*, 4-8 May, Yamoussoukro, Ivory Coast, CTA,FAO, IAPC, ORSTOM. Wagenigen, Netherlands, pp. 125-130.
- Bock, K.R.,1994a.** The spread of African cassava geminivirus in coastal Kenya. *Trop. Sci.* **34**, 92-101.
- Bock, K.R.,1994b.** Control of African cassava mosaic geminivirus by using virus-free planting material. *Trop. Sci.* **34**, 102-109.

- Bock, K.R., 1994c.** Studies on cassava brown streak virus disease in Kenya. *Trop. Sci.* **34**, 134-145.
- Bock, K.R., and Guthrie, E.J., 1978.** African mosaic disease in Kenya. In: *Proceedings of cassava protection workshop, CIAT, Cali, Columbia, 7-12 November 1977*, pp. 41-44 (Brekelbaum, T., Belloti, A. and Lazano, J.C., eds.). Series CE-14. Cali, Colombia.
- Bock, K.R., and Guthrie, E.J., 1982.** Control of cassava mosaic disease in Kenya. *Trop. Pest manage.* **28**, 219-222.
- Bock, K.R., and Woods, R.D., 1983.** Etiology of African cassava mosaic disease. *Plant Dis.* **67**, 994-995.
- Bock, K.R., Guthrie, E.J. and Figueiredo, G., 1981.** A strain of cassava latent virus occurring in coastal districts of Kenya. *Ann. Appl. Biol.* **99**, 151-159.
- Bock, K.R., Guthrie, E.J. and Meredith, G. C., 1978.** Distribution, host range, properties and purification of cassava latent virus, a geminivirus. *Ann. Appl. Biol.* **90**, 361-367.
- Briddon, R.W., and Markham, P.G., 1995.** Geminiviridae. In : *Virus taxonomy : Sixth report of the International Committee on Taxonomy of Viruses*, pp. 158-165. Murphy, F.A., Fauquet, C.M., Bishop, D.H.L., Ghabrial, S.A., Jarvis, A.W., Martelli, G.P., Mayo, M.A. and Summers, M.D., eds. Springer Verlag, Wien and New York.
- Briddon, R.W., Liu, S., Pinner, M.S., and Markham, P.G., 1998.** Infectivity of African cassava mosaic clones to cassava by biolistic inoculation. *Arch. Virol.* **143**, 2487-2492.
- Briddon, R.W., Pinner, M.S., Stanley, J. and Markham, P.G., 1990.** Geminivirus coat protein gene replacement alters insect specificity. *Virology* **177**, 85-94.
- Brough, C.L., Hayes, R.J., Morgan, A. J., Coutts, R.H.A., and Buck, K.W., 1988.** Effects of mutagenesis in vitro on the ability of cloned tomato golden mosaic virus DNA to infect *Nicotiana benthamiana* plants. *J. Gen. Virol.* **69** , 503-514.

- Burnette, W.M., 1981.** 'Western blotting': Electrophoretic transfer of proteins from sodium dodecyl sulfate-polyacrylamide gels to unmodified nitrocellulose and radiographic detection with antibody and radioiodinated protein A. *Anal. Biochem.* **112**, 195-203.
- Byrne, D.N., and Houk, M.A., 1990.** Morphometric identification of wing polymorphism in *Bemisia tabaci*. *Ann. Entomol. Soc. America* **83**, 487-493.
- Campbell, A.M., 1984.** Monoclonal antibody technology. The production and characterization of Rodent and Human hybridomas. *Elsevier, New York*, 265 pp.
- Carter, S.E., and Jones, P.G., 1989.** COSCA, *Working Paper No.2*, COSCA site selection procedure, IITA, Ibadan, Nigeria, 19 pp.
- Casper, R., and Meyer, S., 1981.** Die Anwendung des ELISA-Verfahrens zum Nachweis pflanzenpathogener Viren. *Nachrichtenblatt des Deutschen Pflanzenschutzdienstes (Braunschweig)* **33**, 49-54.
- Chatterji, A., Padidam, M., Beachy, R.M., and Fauquet, C. M., 1999.** Identification of replication specificity determinants in two strains of tomato leaf curl from New Dheli. *Journal of Virology* **73**, 5481-5489.
- Clark, M.F., and Adams, N., 1977.** Characteristics of the microplate method of the enzyme-linked immunosorbent assay (ELISA) for the detection of plant viruses. *J. Gen. Virol.* **34**, 475-483.
- Cohen, S., Duffus, J.E., Larsen, R.C., Liu, H.Y., and Flock, R.A., 1983.** Purification, serology and vector relationship of squash leaf curl virus, a whitefly transmitted geminivirus. *Phytopathology* **73**, 1669-1673
- Cours, G., 1951.** Le Manioc à Madagascar. *Memoires de l'Institut Scientifique Madagascar, Série B Tome III Fascule, 2*, 203 – 400.
- Dellaporta, S.L., Wood, J., and Hicks, H.B., 1983.** A plant DNA miniprep: Version II. *Plant Mol. Bio. Rep.* **14**, 19-21.
- Deng, D., Otim-Nape, G.W., Sangare, A., Ogwai, S., Beachy, R.N., and Fauquet, C.M., 1997.** Presence of a new virus associated with cassava mosaic outbreak in Uganda. *African Journal of Root and Tuber Crops* **2**, 23-28.

- Derrick, K.S., 1973.** Quantitative assay for plant viruses using serologically specific electron microscopy. *Virology* **56**, 652-653.
- Dijkstra, J., and de Jager, C. P., 1998.** Practical Plant Virology, Protocols and Exercises. *Springer lab Manual, Berlin, Germany.*
- Dubern, J., 1979.** Transmission of African cassava mosaic geminivirus by the whitefly, Bemisia tabaci. *Trop. Sci.* **34**, 82-91.
- Eagle, P.A., Orozco, P.M., and Hanley-Bowdoin, L., 1994.** A DNA sequence required for geminivirus replication also mediates transcriptional regulation. *Plant Cell* **6**, 1157-1170.
- Elmer, J.S., Brand, L. Sunter, G., Gardiner, W.E., Bisaro, D.M., and Rogers, S.G., 1988.** Genetic analysis of tomato golden mosaic virus II. Requirement for the product of the highly conserved AL1 coding sequence for replication. *Nucleic Acids Research* **16**, 7043-7060.
- Esler, G., and Coley-Smith, J.R., 1984.** Resistance to Scelerotium cepivorum in Allium and other genera. *Plant Pathol.* **33**, 199-204.
- Etessami, P., Saunders, K., Watts, J., and Stanley, J., 1991.** Mutation analysis of complementary-sense genes of African cassava mosaic virus DNA A. *J. Gen. Virol.* **72**, 1005-1012.
- Etessami, P., Watts, J., and Stanley, J., 1989.** Size reversion of African cassava mosaic virus coat protein gene deletion mutants during infection of Nicotiana benthamiana. *J. Gen. Virol.* **70**, 277-289.
- FAO, 1997.** Production data 1998. <http://www.fao.org>.
- FAO, 1999.** Production data 1998. <http://www.fao.org>.
- FAO, 2000.** Production data 1998. <http://www.fao.org>.
- Fargette, D. and Fauquet, C.M., and Thouvenel, J-C., 1988.** Yield losses induced by African cassava virus in relation to mode and date of infection. *Trop. Pest manage.* **34**, 89-91.
- Fauquet, C.M., and Fargette, D., 1990.** African cassava mosaic virus: Etiology, epidemiology and control. *Plant Dis.* **74**, 404-411.

- Fauquet, C.M., Fargette, D., and Thouvenel, J-C., 1988.** Some aspects of the epidemiology of African cassava mosaic virus in Ivory Coast. *Trop. Pest. manage.* **34**, 89-91.
- Fauquet, C.M., Maxwell D.P., Gronenborn, B., and Stanley, J. 2000.** Revised proposal for naming geminiviruses. *Arch. Virol.* **145**,1743-1761
- Felsenstein, J, 1985.** Confidence limits on phylogenies: an approach using the bootstrap. *Evolution* **39**, 783-791.
- Fishpool, L.D.C., Fauquet, C., Fargette, D., Thouvenel, J.C., Burban, C., and Colvin, J., 1995.** The phenology of *Bemisia tabaci* populations (Homoptera: Aleyrodidae) on cassava in Southern Cote D'Ivoire. *Entomological Research*, **85**,197-207.
- Fondong, V.N., Pita, J.S., Rey, M.E.C., De Kochko, A., Beachy R.N., and Fauquet, C.M., 2000.** Evidence of synergism between African cassava mosaic virus and a new double combination virus infecting cassava in Cameroon. *J. Gen. Virol.* **81**, 287-297.
- Fontes, E. P. B., Eagle, P. A., Sipe, P. S., Luckow, V. A., Hanley-Bowdoin, L., 1994.** Interaction between a geminivirus replication protein and origin DNA is essential for viral replication. *J. Biol. Chem.* **269**, 8459-8465.
- Frischmuth, T., and Stanley, J., 1998.** Recombination between viral DNA and the transgenic coat protein gene of African cassava mosaic geminivirus. *J. Gen. Virol.* **79**, 1265-1271.
- Frischmuth, T., Engel, M., Lauster, S., and Jeske, H., 1997.** Nucleotide sequence evidence for the occurrence of three distinct whitefly-transmitted, *Sida* infecting bipartite geminiviruses in Central America. *J. Gen. Virol.* **78**, 2675-2682.
- Frischmuth, T., Roberts, S., von Amim, A., and Stanley, J., 1993.** Specificity of bipartite geminivirus movement proteins. *Virology* **196**, 666-673.
- Geddes, A.M.W., 1990.** The relative importance of crop pests in subsaharan Africa. *Bulletin* 36; Chatham: Natural resource institute, UK.

- Gibson, R.W. 1996.** The report of a survey monitoring the spread of the epidemic of the African cassava mosaic virus from Uganda into Western Kenya. *Internal report. Natural Resources Institute, Chatham, UK.* 17pp.
- Gibson, R.W., and Otim-Nape, G. W., 1997.** Factors determining recovery and reversion in mosaic-affected African cassava mosaic virus resistant cassava. *Ann. Appl. Biol.* **131**, 259-271.
- Gibson R.W., Legg, J.P., and Otim-Nape, G.W., 1996.** Unusually severe symptoms are a characteristic of the current epidemic of mosaic virus disease in Uganda. *Ann. Appl. Biol.* **128**, 479-490.
- Gilbertson, R.L., Hidayat, S.H., Paplomatas, E.J., Rojas, M.R., Hou, Y.M., and Maxwell, D.P., 1993.** Pseudorecombination between infectious cloned DNA components of tomato mottle and bean dwarf mosaic geminiviruses. *J. Gen. Virol.* **74**, 23-31.
- Golding, F.D., 1936.** Cassava mosaic in Southern Nigeria. *Bulletin of the Department of Agriculture, Nigeria*, **11**, 1-10.
- Gray, D.J., and Finer, J.J., 1993.** Development and operation of five particle guns for introduction of DNA into plant cells. *Plant Cell Tiss. Org. Cult.* **33**, 219.
- Hahn, S.K., Terry, E.R., and Leuschner, K., 1980.** Breeding cassava for resistance to cassava mosaic virus. *Euphytica* **29**, 673-683.
- Hamilton, R.I., Edwardson, J.R., Francki, R.I.B., Hsu, H.T., Hull, R., Koenig, R., and Milne, R.G., 1981.** Guidelines for the identification and characterization of plant viruses. *J. Gen. Virol.* **54**, 223-241.
- Hanahan, D., 1983.** Studies on the transformation of *Escherichia coli* with plasmids. *J. Mol. Biol.* **166**, 557-580.
- Harrison, B.D., and Robinson, D.J., 1988.** Molecular variation in vector-borne plant viruses: Epidemiological significance. *Phil. Trans. R. Soc. London Ser. B* **321**, 447-462.
- Harrison, B.D., and Robinson, D.J., 1999.** Natural genomic and antigenic variation in whitefly-transmitted geminiviruses (begomoviruses). *Annu. Rev. Phytopathol.* **37**, 369-389

- Harrison, B.D., Liu, Y.L., Khalid, S., Hameed, S., and Otim-Nape G.W., 1997.** Detection and relationship of Cotton leaf curl virus and allied whitefly transmitted geminiviruses occurring in Pakistan. *Ann. App. Biol.* **130**, 61-75.
- Harrison, B.D., Swanson, M.M, and Robinson, D.J., 1995.** Cassava viruses in the old world. pp 463-472 volume **2**. *Proceedings: Second International Scientific meeting of the Cassava Biotechnology Network, Bogor, Indonesia, 22-26 August 1994*. Working document No. 150, CBN/CRIFC/AARD/CIAT.
- Harrison, B.D., Swanson, M.M., McGrath, P.F., and Fargette, D. 1991.** Patterns of antigenic variation in whitefly transmitted geminiviruses. *Report of the Scottish Crop Research Institute for 1990*, pp 88-90.
- Herren, H.R., and Neuenschwander, 1991.** Biological control of Cassava pests in Africa. *Ann. Rev. Entomol.* **36**, 257-283.
- Höfer, P., Bedford, I.D., Markham, P.G., Jeske, H., and Frischmuth, T., 1997.** Coat protein gene replacement results in whitefly transmission of an insect nontransmissible geminivirus isolate. *Virology* **236**, 288-295.
- Hollings, M., and Brunt, A.A., 1981.** Potyvirus group. *CMI/AAB Description of plant viruses* 245, Kew, England. 7pp.
- Hong, Y.G., Robinson, D.J., and Harrison B.D. 1993.** Nucleotide sequence evidence for the occurrence of three distinct whitefly transmitted geminiviruses in cassava. *J. G. Virol.* **74**, 2437-2443.
- Hunter, H.B., Hiebert, E., Webb, S.E., Tsai, J.H., and Polston, J.E., 1998.** Location of geminiviruses in the whitefly *Bemisia tabaci* (Homoptera: Aleyrodidae). *Plant Dis.* **82**, 1147-1151.
- James, W.C., 1974.** Assessment of plant diseases and losses. *Ann. Rev. Phytopath.* **12**, 27-48.
- Jennings, D.L., 1957.** Further studies in breeding cassava for virus resistance. *East Afr. Agric. Journ.* **22**, 213-218.
- Johnston, B.F., 1958.** The staple food economies of Western tropical Africa. *Food Research Institute, California, USA*, 305pp.
- Jones, W.O., 1959.** Manioc in Africa. California, USA.

- Jupin, I., De Kouchkovsky, F., Jouanneau, F., and Gronenborn, B., 1994.** Movement of tomato yellow leaf curl geminivirus (TYLCV): involvement of the protein encoded by ORF C4. *Virology* **204**, 82-90.
- Kisgeci, J., 1989.** Agricultural biomass for energy, *CNRE study No. 4, University of Novi Sad, Food and Agricultural Organisation of the United Nations*, Vol. **21**, Nos. 58-9, Novi Sad.
- Klinkenberg, A., Ellwood, S., and Stanley, J., 1989.** Fate of african cassava mosaic virus coat protein deletion mutants after agroinoculation. *J.Gen.Virol.* **70**, 1837-1844.
- Kufferath, H., and Chesquière, J., 1932.** La mosaïque du manioc. *Compte-Rendu de la Société de Biologie Belge* **109**, 1146.
- Laemmli, U.K., 1970.** Cleavage of structural proteins during the assembly of the head of bacteriophage T4. *Nature* **227**, 680-685.
- Langeveld, S.A., Dore, J.-M., Memelink, J., Derks, A.F.L.M., Van der Vlugt, C.I.M., Asjes, C.J., and Bol, J.F., 1991.** Identification of potyviruses using the polymerase chain reaction with degenerate primers. *J. Gen. Virol.* **72**, 1531-1541.
- Laufs, J., Jupin, I., David, C., Schumacher, S., Heyraud-Nitschke, F., and Gronenborn, B., 1995.** Geminivirus replication: genetic and biochemical characterization of Rep protein function, a review. *Biochimie* **77**, 765-773.
- Lazarowitz, S.G., Wu, L.C., Rogers, S.G., and Elmer, J.S., 1992.** Sequence specific interaction with the viral AL1 protein identifies a geminivirus DNA replication origin. *Plant Cell* **4**, 799-809.
- Legg, J.P., and Okoa-Okuja, G., 1999.** Progress in the diagnosis and epidemiological characterisation of cassava mosaic geminiviruses in East Africa. *Proceedings of the VIIth International Plant Epidemiological Symposium, Aguadulce (Almeria), Spain*, April 11-16, 1999. Abstract. 74-75.
- Legg, J.P., and Raya, M.D. 1998.** Survey of cassava virus diseases in Tanzania. *Int. J. Pest Manage.* **44**, 17-23.

- Legg, J.P., Sseruwagi, P., Kamau, J., Ajang, S., Jeremiah, S.C., Aritua, V., Otim-Nape, G.W., Muimba-Kankolongo, A., Gibson, R.W., and Thresh, J.M., 1999.** The pandemic of severe cassava mosaic disease in East Africa. In: *Aroda, M.O., Teri, J.M. (Eds) Proceedings of the Scientific workshop of the South African Root Crops Research Network (SARNET), Lusaka, Zambia, 17-19 August 1998.* pp. 236-251.
- Lennon, A.M., Aiton, M.M., and Harrison, B.D., 1986.** *Rep. Scottish Crop Res. Inst.* 1985, p. 168.
- Leuschner, K., 1978.** Preliminary observation on the mealybug (Hemiptera pseudococcidae) in Zaire and a projected outline for subsequent work. *Proceedings of the international workshop on cassava mealybug, Phenacoccus manihoti Mat.-Ferr (Pseudococcidae)*, IITA, Nigeria, 15-19.
- Lin, N.S., Hsu, Y.H., and Hsu, H.T., 1990.** Immunological detection of plant viruses and a mycoplasma-like organism by direct tissue blotting on nitrocellulose membranes. *Phytopathology* **80**, 824-828.
- Lindsay, K.L., and Mashall, A.T., 1981.** The osmoregulatory role of the filter chamber in relation to phloem feeding in *Eurymela distincta* (Cicadelloidea, Homoptera). *Physiol. Entomol.* **6**, 413-419.
- Macintosh, S., Robinson, D.J., and Harrison, B.D., 1992.** Detection of three whitefly-transmitted geminiviruses occurring in Europe by tests with heterologous monoclonal antibodies. *Ann. Appl. Biol.* **121**, 297-303.
- Martin, J.H., 1987.** An identification guide to common whitefly species of the world. *Trop. Pest Manage.* **33**, 298-322.
- Mathews, R.E.F., 1991.** *Plant virology*, 2nd edition, Academic Press New York.
- Milne, R.G., and Lesemann, D-E., 1984.** Immunosorbent electron microscopy in plant virus studies. *Methods in Virology VIII*, 85-101.
- Mogilaer, I., Orioli, G.A., and Bletter, C.N., 1967.** Trial to study tropophysis and photoperiodism in cassava. *Bouplandia* **2**, 265-272.

- Mound, L.A., 1963.** Host correlated variation in *Bemisia tabaci* (Gennadius)(Homoptera:Aleyrodidae). *Proceedings of the Royal Entomological Society of London (A)* **38**, 171-180.
- Mound, L.A., and Halsey, S.H., 1978.** Whitefly of the world. A systematic catalogue of the Aleyrodidae (Homoptera) with host plant and natural enemy data. *British Museum (Natural History), London*. 340pp.
- Muniyappa, V., Swanson, M.M., Duncan, G.H., and Harrison, B.D., 1991.** Particle purification of Indian tomato leaf curl geminivirus. *Ann, Appl. Biol.* **118**, 595-604,.
- Murray, H.G., and Thompson, W.F., 1980.** Rapid isolation of high molecular weight DNA. *Nucleic Acids Research* **8**, 4321-4325.
- Natesh, H.M., Muniyapa, V., Swanson, M.M., and Harrison, B.D., 1996.** Host range, vector relationships and serological relationships of cotton leaf curl virus from southern India. *Ann. Appl. Biol.* **128**, 233-244.
- Nichols, R.F.W., 1947.** Breeding cassava for virus resistance. *East. Afri. Agri. Journ.* **15**, 154-160.
- Noris, E., Vaira, A.M., Caciagli, P., Masenga, V., Gronenborn, B., and Accotto, G.P., 1998.** Amino acids in the capsid protein of tomato yellow leaf curl virus that are crucial for systemic infection, and insect transmission. *Journal of Virology* **72**, 10050-10057.
- Noueiry, A.O., Lukas, W.J., and Gilbertson, R.L., 1994.** Two proteins of a plant DNA virus coordinate nuclear and plasmodesmal transport. *Cell* **76**, 925-932.
- Nyiira, Z.M., 1972.** Report of the investigation of cassava mite, *Mononychellus tanajoa* Bonder. Kawanda research station, Kampala, Uganda.
- Ogbe, F.O., Legg, J., Raya, M.D., Muimba-Kankolongo, A., Theu, M.P., Kaitisha, G., Phiri, N.A., and Chalwe, A. 1997.** Diagnostic survey of cassava mosaic viruses in Tanzania, Malawi and Zambia. *Roots* **4**, 12-15.
- Ogbe, F.O., Songa, W., and Kamau, J.W. 1996.** Survey of the incidence of African cassava mosaic and East African cassava mosaic viruses in Kenya and Uganda using a monoclonal antibody based diagnostic test. *Roots* **3**, 10-13.

- Otim-Nape, G.W., 1993.** Epidemiology of the African cassava mosaic geminivirus disease (CMD) in Uganda. *Ph.D thesis, University of Reading, UK.* 256pp.
- Otim-Nape, G.W., Bua, A., Thresh, J.M., Baguma, Y., and Ogwal, S., 1997.** Cassava Mosaic Virus Disease in Uganda: The current pandemic and approaches to control. *Chatham, UK: Natural Resource Institute* 65pp.
- Otim-Nape, G.W., Thresh, J.M., and Fargette, D., 1996.** Bemisia tabaci and cassava mosaic virus disease in Africa. In: *Bemisia 1995: Taxonomy, Biology, Damage, Control and Management.* p. 319-350 (Gerling, D and Mayer, R.T., eds.). *Intercept Andover, U.K.*
- Otim-Nape, G.W., Thresh, J.M., and Shaw, M.W., 1998.** The incidence and severity of cassava mosaic virus disease in Uganda: 1920-1992. *Trop. Sci.* **38**, 25-37.
- Pacumbala, R.P., 1985.** Virus-free shoots from cassava stem cuttings infected with cassava latent virus. *Plant Dis.* **69**, 231-232.
- Padidam, M., Beachy, R.N., and Fauquet, C.M., 1995.** Classification and identification of geminiviruses using sequence comparisons. *J. Gen. Virol.* **76**, 249-263.
- Padidam, M., Beachy, R.N., and Fauquet, C.M., 1996.** The role of AV2 (precoat) and coat protein in viral replication and movement in tomato leaf curl geminivirus. *Virology* **224**, 390-404.
- Padidam, E., Sawyer, S., and Fauquet, C.M., 1999.** Possible Emergence of New Geminiviruses by Frequent Recombination. *Virology* **265**, 218-225.
- Pascal, E., Sanderfoot, A.A., Ward, B.M., Medville, R., Turgeon, R., and Lazarowitz, S.G., 1994.** The geminivirus BR1 movement protein binds single stranded DNA and localises to the cell nucleus. *Plant Cell* **6**, 995-1006.
- Pita, J.S., Fodong, V.N., Sangaré, A., Otim-Nape G.W., and Fauquet C.M., 2001.** Recombination, pseuderecombination and synergism of geminiviruses are determinant keys to the epidemic of severe cassava mosaic disease in Uganda. *J. Gen. Virol.* **82**, 655-665.

- Purseglove, J.W., 1968.** Tropical crops-Dicotyledonous 1. Longmans, London, 332 pp.
- Rey, M.E.C., and Thompson, G., 1998.** Cassava mosaic virus disease in South Africa. *Roots* **5(1)**, 3-5.
- Rigden, J.E., Dry, I.B., Mullineaux, P.M., and Rezaian, M.A., 1993.** Mutagenesis of the virion-sense open reading frames of tomato leaf curl geminivirus. *Virology* **193**, 1001-1005.
- Rigden, J.E., Krake, L.R., Rezaian, M.A., and Dry, I.B., 1994.** ORF C4 of tomato leaf curl geminivirus is a determinant of symptom severity. *Virology* **204**, 847-850.
- Roberts, I.M., Robinson, D.J., and Harrison, B.D., 1984.** Serological relationships and genome homologies among geminiviruses. *J. Gen. Virol.* **65**, 1723-1730.
- Robertson, I.A.D., 1987.** The role of Bemisia tabaci (Gennadius) in the epidemiology of ACMV in East Africa. Biology, population dynamics and interaction with cassava varieties. In : *Proceedings of the International Seminar on African cassava mosaic disease and its control, 4-8 May, Yamoussoukro, Ivory Coast, CTA, FAO, IAPC, ORSTOM. Wageningen, Netherlands*, pp 57-63.
- Rojas, M.R., Gilbertson, R.L., Russell, D.R., and Maxwell, D.P. 1993.** Use of degenerate primers in the polymerase chain reaction to detect whitefly-transmitted geminiviruses. *Plant Dis.* **77**, 340-347 .
- Rossel, H.W., Thottappilly, G., Van Lent, J.M.W., and Huttinga, H., 1988.** The etiology of cassava mosaic in Nigeria. In: *Proceedings of International Seminar on African cassava mosaic disease and its control*, pp. 43-46 (Fauquet, C. and Fargette, D., eds.) Wageningen: CTA/FAO/ORSTOM/IITA/IAPC.
- Rossel, R.C., Torres-Jerez, I., and Brown, J.K., 1997.** Temporal monitoring of geminivirus DNA in whitefly hemolymph by polymerase chain reaction (PCR). (Abstr.) *Phytopathology* **87**, 583.
- Rossel, R.C., Torres-Jerez, I., and Brown, J.K., 1999.** Tracing the geminivirus-whitefly transmission pathway by polymerase chain reaction in whitefly extracts, Saliva, Hemolymph and Honeydew. *Phytopathology* **89**, 239-246.

Rybicki, E.P., 1994. A phylogenetic and evolutionary justification for three genera of geminiviridae. *Arch. Virol.* **139**, 49-77.

Saitou N., and Nei M. 1987. The neighbour-joining method : A new method for reconstructing phylogenetic trees. *Molecular Biology Evolution* **4**, 406-425.

Sambrook, J., Fritsch, E.F., and Maniatis, F., 1989. Molecular cloning: A laboratory manual, 2nd edn. Cold Spring Harbor, New York : Cold Spring Laboratory.

Sanderfoot, A.A., Ingham, D.J., and Lazarowitz, S.G., 1996. A viral movement protein as a nuclear shuttle – the geminivirus BR1 contains domains essential for interaction with BL1 and nuclear localization. *Plant Physiol.* **110**, 23-33.

Sanderfoot, A.A., and Lazarowitz, S.G., 1996. Getting it together in plant virus movement: Co-operative interaction between bipartite geminivirus movement proteins. *Trends Cell Biol.* **6**, 353-358.

Saunders, K., Lucy, A., and Stanley, J., 1991. DNA forms of the geminivirus African cassava mosaic virus consistent with a rolling-circle mechanism of replication. *Nucleic Acids Res.* **19**, 2325-2330

Schaab, R., 1977. economy and ecology of biological control activities in africa. case study on the cassava mealybug, *Phenacoccus manihoti* Mat.-Ferr. *Ph.D thesis, Universität Hohenheim, Marburg* , 141 pp.

Scott, G., Best, R., Rosegrant, M., and Bokanga, M., 2000a. Roots and tubers in the global food system. A vision statement to the year 2020. *Food, Agriculture and the Environment Discussion paper. IFPRI-CIP. Washington, D.C.*

Scott, G., Best, R., Rosegrant, M. and Ringler, C., 2000b. Trends and projections for Roots and Tuber Crops to the year 2020. *Food, Agriculture and the Environment Discussion paper. IFPRI-CIP. Washington, D.C.*

Seif, A.A., 1982. Effect of cassava mosaic virus on yield of cassava. *Plant Dis.* **66**, 661-662.

Sequeira, J.C., and Harrison, B.D., 1982. Serological studies on cassava latent virus. *Ann. Appl. Biol.*, **101**, 33-42.

- Shukla, D.D., and Ward, C.W., 1988.** Amino acid sequence homology of coat protein as a basis for identification and classification of the potyvirus group. *J. Gen. Virol.* **69**,2703-2710.
- Shukla, D.D., Strikes, P.M. Tracy, S.L., Gough, K.H., and Ward, C.W., 1988.** The N and the C terminal of the proteins of potyviruses are surface coated and the N terminus contains the major virus specific epitopes. *J. Gen. Virol.* **69**:1497-1505.
- Stanley, J., 1995.** Analysis of African cassava mosaic virus recombinants suggests strand nicking occurs with the conserved nonanucleotide motif during the initiation of rolling cycle DNA replication. *Virology* **206**, 707-712.
- Stanley, J., and Gray, M.G., 1983.** Nucleotide sequence of cassava latent virus DNA. *Nature*, **301**, 260-262.
- Stanley, J., Townsend, R., and Curson, S.J., 1985.** Pseudorecombination between cloned DNAs of two isolates of cassava latent virus. *J. Gen. Virol.* **66**, 1055-1061.
- Stein, V.E., Coutts, R.H.A., and Buck, K.W., 1983.** Serological studies on Tomato Golden Mosaic Virus, a geminivirus. *J. Gen. Virol.* **64**, 2493-2498.
- Storey, H.H., 1936.** Virus diseases of East African plants, VII-A progressive report on the studies of the disease of cassava. *East Afr. Agric. Journ.* **2**, 34-39.
- Storey, H.H., 1938.** Virus diseases of East African plants, VII-A field experiment in the transmission of cassava mosaic virus. *East Afr. Agric. Journ.* **3**, 446-449.
- Storey, H.H., and Nichols, R.F.W., 1938.** Studies on the mosaic of cassava. *Ann. Appl. Biol.* **25**, 790-806.
- Sunter, G., and Bisaro, D.M., 1991.** Transactivation in a geminivirus: AL2 gene product is needed for coat protein expression. *Virology* **180**, 416-419.
- Sunter, G., Hartitz, M.D., Hprmuzdi, S.G., Brough, C.L., and Bizaro, C.M., 1990.** Genetic analysis of tomato golden mosaic virus: ORF AL2 is required for coat protein accumulation while ORF AL3 is necessary for efficient DNA replication. *Virology* **179**, 69-72.
- Swanson, M.M., 1992.** Antigenic variation and serological relationships of whitefly transmitted geminiviruses. *Ph.D thesis, University of Dundee, UK.* 259 pp.

- Swanson, M.M., Brown, J.K., Poulos, B.T., and Harrison, B.D., 1992.** Genomic affinities and epitope profiles of whitefly transmitted geminiviruses from the Americas. *Ann. Appl. Biol.* **121**, 285-296.
- Swanson, M.M., and Harrison, B.D., 1993.** Serological relationships and epitope profiles of isolates of Okra leaf curl geminivirus from Africa and the middle east. *Biochemie* **75**, 707-711.
- Taggart, R.T., and Samloff, I.M., 1983.** Stable antibody producing murine hybridomas. *Science* **219**, 1228-1230.
- Thomas, J.E., Massalski, P.R., and Harrison, B.D., 1986.** Production of monoclonal antibodies to African cassava mosaic virus and differences in their reactivity with other whitefly transmitted geminiviruses. *J. Gen. Virol.* **67**, 2739-2749.
- Thompson, J.D., Higgins, D.G., and Gibson, T.J., 1994.** CLUSTAL W: improving the sensitivity of progressive multiple sequence alignment through sequence weighting, positions-specific gap penalties and weight matrix choice. *Nucleic Acids Research* **22**, 4673-4680.
- Thresh, J.M., Fishpool, L.D.C., Otim-Nape, G.W., and Fargette, D., 1994.** African cassava mosaic virus disease: an under-estimated and unsolved problem. *Trop. Sci.* **34**, 3-14.
- Thresh, J.M., Otim-Nape, G.W., Legg, J.P. and Fargette, D., 1997.** African cassava mosaic disease: What is the magnitude of the problem? *African Journal Root and Tuber Crops* **2**, 13-19.
- Towbin, H., Staehelin, T. and Gordon, J., 1979.** Electrophoretic transfer of proteins from polyacrylamide gels to nitrocellulose sheets: a procedure and some applications. *Proc.Nat.Acad. Sci. USA* **76**, 4350-4354.
- Varrelmann, M., 1999.** Begrenzung von heterologer Enkapsidierung und Rekombination bei pathogen-vermittelter Resistenz gegen das *Plum pox virus* der Pflaume. Dissertation, Fachbereich Gartenbau der Universität Hannover, 230pp.
- Warburg, O., 1894.** Die Kulturpflanzen Usambaras. *Mitteilungen aus den Deutschen Schutzgebieten* **7**, 131.

- Ward, B.M., Medville, R., Lazarowitz, S.G., and Turgeon, R., 1997.** The geminivirus BL1 movement protein is associated with endoplasmic reticulum derived tubules in developing phloem cells. *Journal of Virology* **71**, 3726-3733.
- Wartig, L., Khey Pour, A., Noris, E., De Kouchkovsky, F., Jouanneau, F., Gronenborn, B., and Jupin, I., 1997.** Genetic analysis of the monopartite tomato yellow leaf curl geminivirus: Roles of V1 and V2, and C2 ORF in viral pathogenesis. *Virology* **228**, 132-140.
- Watts Padwick, G., 1956.** Losses caused by plant diseases in the colonies. *Phytopathological Papers 1/Commonwealth Mycological Institute, Kew, Surrey*, 60p.
- Weising, K., Schell, J., and Kahl, G., 1988.** Foreign genes in Plants: transfer, structure, expression and application. *Ann.Rev.Genet.* **22**, 421-477.
- Wright, R.M., 1996.** Jamaica's Energy: Old prospects, New resources. *Twin Guinep publishers/Stephenson's Litho Press*.
- Xu, H., Leclerc, D., Leung, B. and AbouHaidar, M.G., 1994.** The entire nucleotide sequence and genomic organization of potato aucuba mosaic virus. *Arch.Virol.* **135**, 461-469.
- Yaninek, J.S., Onzo, A., and Ojo, J.B., 1993.** Continental-wide releases of neotropical predators against the exotic cassava green mites in Africa. *Exp. Appl. Acarol.* **17**, 145-160.
- Zhan, X., Haley, A., Richardson, K., and Moris, B., 1991.** Analysis of the potential promoter sequence of the African cassava mosaic virus by transient expression of the β -glucuronidase gene. *J. Gen. Virol.* **72**, 2849-2852.
- Zhang,W., Olsen, N.H., Baker, T.S., Faulkner, L., Akbandje- McKenna, M., Boulton, M.I., Davies, J.W., and McKenna, R., 2001.** Structure of the Maize streak virus geminate particle. *Virology* **20**, 279 (2), 471-477.
- Zhou, X., Liu, Y., Calvert, L., Munoz, D., Otim-Nape, G.W., Robinson, D.J., and Harrison, B.D., 1997.** Evidence that DNA-A of a geminivirus has arisen by interspecific recombination. *J. Gen. Virol.* **78**, 2101-2111.

Zhou, X., Robinson, D.J., and Harrison B.D., 1998. Types of variation in DNA A among isolates of East African cassava mosaic virus from Kenya, Malawi and Tanzania. *J. Gen. Virol.* **79**, 2835-2840.

5. ANNEX

| List of tables | page |
|--|-------------|
| Tab. 1 Countries and cities/locations from which CMD infected cassava samples were obtained | 17 |
| Tab. 2 Antibodies used for serological analysis of cassava samples | 22 |
| Tab. 3 Primers used to detect viral DNA-A fragments in cassava samples from Africa | 49 |
| Tab. 4 Primer combinations and annealing temperatures used for detection of different begomoviruses in cassava | 50 |
| Tab. 5 Primer combinations used to amplify cassava begomovirus coat protein genes | 54 |
| Tab. 6 Primers used to amplify full-length DNA-A and DNA-B components of cassava begomoviruses | 61 |
| Tab. 7 Primer combinations used to amplify full-length DNA-A and DNA-B components | 62 |
| Tab. 8 Infectivity of 20 cassava begomovirus isolates to <i>N. benthamiana</i> by sap and biolistic inoculation | 79 |
| Tab. 9 Reactions of MAbs raised against TYLCV and EACMV in TAS-ELISA with cassava mosaic begomoviruses from Africa and ICMV from India | 84 |
| Tab. 10 Properties of some monoclonal antibodies that were used in routine analysis | 86 |
| Tab. 11 Differential reactions of four monoclonal antibodies in TAS-ELISA for definition of an African cassava mosaic begomovirus type | 87 |
| Tab. 12 Detection of begomoviruses in CMD-infected cassava samples from different districts in Kenya by PCR and TAS-ELISA | 95 |
| Tab. 13 Identification of begomovirus types in CMD-affected cassava samples collected from various African countries | 99 |
| Tab. 14 Comparison of nucleotide and deduced amino acid sequences of Ca002 DNA- A and respective ORFs with those of other begomoviruses from cassava | 117 |

| | |
|---|--------------------|
| Tab. 15 Infectivity of cloned begomoviral DNA-A and DNA-B in <i>N. benthamiana</i> | page 120 |
| Tab. 16 Reaction of test plants upon inoculation with sap of cassava clone Ca119 | 122 |

List of figures

| | |
|---|----|
| Fig. 1 Genome organisation of a typical begomovirus | 8 |
| Fig. 2 DNA-A components of EACMV, ACMV and UgV | 12 |
| Fig. 3 Map of Kenya showing locations from which cassava samples with CMD symptoms were collected | 18 |
| Fig. 4 Subcloning of a DNA-A fragment containing the origin of replication into pBSK- | 63 |
| Fig. 5 Construction of a partial head-to-tail dimer of Ca002 genomic component DNA-A | 64 |
| Fig. 6 Cloning of a full-length NcoI DNA-B fragment of Ca002 into pGEM-T | 65 |
| Fig. 7 Subcloning of a partial 0.3 full-length DNA-B fragment into pBSK- | 66 |
| Fig. 8 Construction of a 1.3 full-length partial head-to-tail dimer of DNA-B genomic component | 66 |
| Fig. 9 The expression vector pET 28a CP 4 construct containing the coat protein gene of EACMV | 68 |
| Fig. 10 Cassava plants with typical symptoms of UgV, EACMV, ACMV + EACMV and ACMV infections | 74 |
| Fig. 11 Symptoms of CMD in <i>N.benthamiana</i> plants after biolistic and sap inoculation | 76 |
| Fig. 12 Electron micrograph showing a negatively stained preparation (1% UAc) of begomovirus particles | 80 |
| Fig. 13 SDS polyacrylamide electrophoresis and electroblot immunoassay for detection of begomoviruses in leaf extracts of cassava plants | 81 |
| Fig. 14 SDS-PAGE of expressed EACMV coat protein | 82 |
| Fig. 15 Detection of UgV by tissue blot immunoassay, TBIA, in shoot sections of <i>N. benthamiana</i> and cassava | 88 |
| Fig. 16 Detection of cassava begomoviruses by dot blot hybridization | 89 |

| | page |
|---|-------------|
| Fig. 17 Gel electrophoresis of PCR amplified DNA fragments with primers specific for ACMV, EACMV, UgV and, begomovirus genus-specific primers | 91 |
| Fig. 18 Typical severe CMD symptoms in cassava in the field with leaves showing mosaic and leaf distortion | 92 |
| Fig. 19 Map of Kenya showing the areas from which cassava samples were collected | 98 |
| Fig. 20 Map of Africa showing the distribution of cassava begomoviruses in cassava growing countries | 102 |
| Fig. 21 Phylogenetic tree constructed from nucleotide sequence alignments of coat protein genes of cassava begomoviruses | 105 |
| Fig. 22 Alignment of nucleotide sequences from selected coat protein genes from ACMV, UgV and EACMV | 106 |
| Fig. 23 Alignment of amino acid sequences from selected coat protein genes of ACMV, UgV and EACMV | 109 |
| Fig. 24 Phylogenetic tree constructed from nucleotide sequence alignments of DNA-A genomic components of cassava begomoviruses | 112 |
| Fig. 25 Alignment of nucleotide sequences from selected DNA-A intergenic regions from ACMV, UgV and EACMV | 114 |
| Fig. 26 Phylogenetic tree constructed from nucleotide sequence alignments of fragments of DNA-B genomic components of cassava begomoviruses | 118 |
| Fig. 27 <i>N. benthamiana</i> showing symptoms of yellow net and vein banding after inoculation with Ca119 | 123 |
| Fig. 28 Reactions of <i>N. glutinosa</i> 24a after infection with cassava filamentous viruses | 124 |
| Fig. 29 Cassava inoculated with sap from <i>N. benthamiana</i> plants showing symptoms of infection with cassava filamentous viruses | 125 |
| Fig. 30 Electron micrograph showing negatively stained preparations of potyvirus-like particles | 127 |

| | | |
|---------|--|-------------|
| Fig. 31 | Electron micrograph of a partial purified virus preparation from <i>N. glutinosa</i> 24a showing carlavirus-like particles | page 128 |
| Fig. 32 | SDS-PAGE analysis of protein preparations of plants infected with Ca119 virus | 129 |

List of begomovirus isolates selected for genetic analysis, geographic origin, DNA-A type and virus species/variant affiliation determined for the respective DNA-A and DNA-B genomic components

| Virus isolate DNA-A | Geographic origin | DNA Type | Virus affiliation |
|--------------------------------|--------------------------|-----------------|--------------------------|
| Ca002 | Siaya, Kenya | DNA-A | EACMV-UgV |
| Ca124 | Kilifi, Kenya | DNA-A | EACMV |
| Ca106 | Busia, Kenya | DNA-A | EACMV-UgV |
| Ca068 | Kisangani, D.R.C | DNA-A | EACMV-UgV |
| Ca070 | Kisangani, D.R.C | DNA-A | EACMV-UgV |
| Ca185 | Kisangani, D.R.C. | DNA-A | EACMV-UgV |
| Ca127 | Siaya, Kenya | DNA-A | EACMV-UgV |
| Ca024/Ca065 | Busia, Kenya | DNA-A | ACMV |
| Ca011/Ca080 | Kinshasa, D.R.C. | DNA-A | ACMV |
| Ca103/Ca104 | Kilifi, Kenya | DNA-A | EACMV |
| Ca122 | Kilifi, Kenya | DNA-A | EACMV |
| | | | |
| | | | |
| | | | |
| DNA-B | | | |
| Ca002 | Siaya, Kenya | DNA-B | ACMV |
| Ca007 | Kakamega, Kenya | DNA-B | ACMV |
| Ca086 | Bas Musongul, D.R.C. | DNA-B | ACMV |
| Ca084/Ca082 | Bas Mboka, D.R.C. | DNA-B | ACMV |
| Ca071 | Khola Kourè, Togo | DNA-B | ACMV |
| Ca074 | Tolo Bengu, Togo | DNA-B | ACMV |
| Ca050/Ca077 | NN, Ghana | DNA-B | ACMV |
| Ca035 | NN, Guinea | DNA-B | ACMV |

Viruses with two sample identifiers, Ca./Ca., are obtained from an identical source plant from which two cuttings were taken

Begomovirus sequences used for comparative analyses, their sequence accession number and assigned abbreviation

| Virus | Abbreviation assigned | Sequence accession numbers |
|------------------------|------------------------------|-----------------------------------|
| DNA-A | | |
| ACMV- Cameroon | ACMV-CM | AF112352 |
| ACMV- Kenya | ACMV-KE | J02057, GE1G |
| ACMV- Kenya | ACMV-KE2 | AF001467 |
| ACMV- Nigeria | ACMV-NG | X17095, GEN1G |
| ACMV- Uganda (mild) | ACMV-UG-Mld | AF126800 |
| ACMV- Uganda (severe) | ACMV-UG-Svr | AF126802 |
| EACMV- Cameroon | EACMV-CM | AF112354 |
| EACMV- Kenya | EACMV-KE | AJ006458 |
| EACMV- Malawi | EACMV-MK | AJ006460 |
| EACMV-Tanzania | EACMV-TZ | Z83256 |
| EACMV- Uganda | EACMV-UG1 | Z83257, CVUV39 |
| EACMV- Uganda | EACMV-UG1a | Z83254, CVC70 |
| EACMV- Uganda (severe) | EACMV-UG2-Svr | AF126806 |
| EACMV- Uganda (mild) | EACMV-UG2-Mld | AF126804 |
| | | |
| SACMV- South Africa | SACMV-ZA | AF155806 |
| CPGMV- Nigeria | CPGMV-NG | AF029217 |
| | | |
| DNA-B | | |
| ACMV-Kenya | ACMV-KE | CLV2G |
| ACMV-Kenya2 | ACMV-KE2 | GE2G |
| ACMV-Uganda (severe) | ACMV-UG-Svr | AF126803 |
| ACMV-Uganda (mild) | ACMV-UG-Mld | AF126801 |
| ACMV-Nigeria2 | ACMV-NG2 | AJ001468 |
| ACMV-Cameroon | ACMV-CM | AF112353 |
| ACMV-Nigeria | ACMV-NG | GEN2G |
| EACMV-Uganda (severe) | EACMV-UG3Svr | AF126807 |
| EACMV-Uganda (mild) | EACMV-UG3-Mld | AF126805 |
| EACMV-Uganda | EACMV-UG1 | AF230375 |
| EACMV-Cameroon | EACMV-CM | AF112355 |
| | | |
| SACMV-South Africa | SACMV-ZA | AF155807 |
| CPGMV-Nigeria | CPGMV-NG | NN |

ACKNOWLEDGEMENTS

This Ph.D work was done at the German Collection of Microorganisms and Cell cultures, Plant Virus Division housed at the Biologische Bundesanstalt (BBA), Braunschweig, Germany.

I would therefore like to express my heartfelt gratitude to the division head Dr. Stephan Winter for allowing me to work in his laboratory and for his professional guidance and encouragement throughout the study. Without his personal effort this work would not have been completed on time.

Thanks go to Prof. Dr. Edgar Maiß for accepting to be my University advisor and first referee. Similar sentiments go to Prof. Dr. Günter Adam for co-refereeing my thesis.

I also wish to thank the staff at the DSMZ plant virus division particularly Dr. Max Schönfelder, Dr. Lina Katul, Dr. Dorothea Gleim, M/s Marianne Koerbler, M/s Anja Butgereitt and Mrs. Ute Zender for their friendly technical support and cooperation.

The tireless effort of Dr. Katul in reviewing this manuscript and her useful suggestions are highly appreciated.

Thanks also go to Dr.J.H. Vetten of the Institute of Biochemistry and Plant Virology, BBA, Braunschweig, for his help during work on monoclonal antibody production.

I am highly indebted to Dr. D.-E. Lesemann for his cooperation and tireless help during the electron microscopic work.

I am grateful to colleagues and staff at the Institute of Biochemistry and Plant Virology without whose help, life would not have been easy for me in the laboratory.

I would like to sincerely thank the German Academic Exchange Service (DAAD) for the fellowship without which this work would have not been possible.

CURRICULUM VITAE

| | |
|-------------------------|--|
| Name | Hassan Were Karakacha |
| Date of birth | 30.11.1967 |
| Place of birth | Busia |
| Marital status | Married to Mwanasha Nimandara |
| Nationality | Kenyan |
| Languages | English, Luyha, Kiswahili, German |
| 1974-1980 | Nambale Primary School (CPE), Nambale, Kenya |
| 1981-1984 | Mbale Secondary School 'O' Level (UCE), Mbale, Uganda |
| 1985-1987 | Kibuli Secondary School 'A' Level (UACE), Kampala, Uganda |
| 1988-1991 | Studies in Agricultural Sciences at the University of Nairobi, Kenya Degree: Bachelor of Science (B.Sc.) in Agriculture |
| 1991-1993 | Employment as Assistant Farm Manager at Baraka Farm, Isiolo, Kenya |
| 1994-1996 | Studies in Plant Pathology at the University of Nairobi, Kenya Degree: Master of Science (M.Sc.) in Plant Pathology |
| 1.1.96-29.7.96 | Practical training in the production of antisera against plant viruses at the Federal Biological Research Centre for Agriculture and Forestry (BBA), Institute for Plant Virology, Microbiology and Biosafety, Braunschweig, Germany |
| 1.10.97-27.3.98 | German language course at the Goethe Institute, Göttingen |
| 1.4.1998 Protection, | Ph.D. studies at the Institute of Plant Diseases and Plant University of Hanover, and experimental work at the German Collection of Microorganisms and Cell Cultures GmbH (DSMZ), Plant Virus Division, Braunschweig, Germany, with the support of a German Academic Exchange Service (DAAD) fellowship. |