

# How to Stop Spread of Misinformation on Social Media:

## *Facebook Plans vs. Right-click Authenticate Approach*

Pardis Pourghomi\*, Fadi Safieddine, Wassim Masri, Milan Dordevic

American University of the Middle East,  
P.O.Box: 220, Dasman, 15453, Kuwait

{Pardis.Pourghomi, Fadi.Safiedinne, Wassim.Masri, Milan.Dordevic}@aum.edu.kw

**Abstract**—One of the key features of social networks is that users are able to share information, and through cascades of sharing information, this information may reach a large number of individuals. The high availability of user-provided contents on online social media facilitates people aggregation around shared beliefs, interests, worldviews and narratives. With lack of means to verify information, social media has been accused of becoming a hot bed for sharing of misinformation. Facebook, as one of the largest social networking services, has been facing widespread criticism on how its newsfeed algorithm is designed thus amplifying dissemination of misinformation. In late 2016, Facebook revealed plans to address fake news on Facebook newsfeeds. In this work, we study the methods Facebook has proposed to combat the spread of misinformation and compare it with our previously proposed approach called ‘Right-click Authenticate’. By analyzing the Business Process Modeling and Notation of both approaches, this paper suggests some key weaknesses and improvements social media companies need to consider when tackling the spread of misinformation online.

**Keywords**—Information Sharing; Misinformation; Social Network; Fact-check; Fake News.

### I. INTRODUCTION

The recent proliferation of social media and the increasing number of users relying on social networks as their main source of news online has changed the traditional way of disseminating information [1]. The high availability and ease of sharing such news on social media networks has led to the emergence of a new model of misinformation propagation, which is by far more complex to track the source or to be deemed reliable compared to traditional media. The new model of propagating misinformation is made possible due to the self-interest of the user sharing a particular story, where information and misinformation are blended together and presented to other users without applying any means of validation or fact-checking techniques [2, 3]. When self-beliefs and selective news sharing are considered in this context, fighting misinformation and trying to correct biased beliefs become very challenging [4]. Social media networks such as Facebook made accessing and sharing information

even easier; users are getting selective posts in their news feed based on their preferences and the stories the social media algorithms identify as something of their interest. Algorithms are getting more intelligent and the media content is getting more customized and more relevant to our taste be that a person is interested in facts or conspiracy theories [5]. Naturally, this new model of news dissemination is compared to the traditional model of media outlets where a responsible editor or reporter is held accountable for examining the source of the information, use common sense to judge its credibility, and investigate further if the story seemed untrue. Furthermore, readers could refer to peer-reviewed sources of information or mainstream media from variety of sources. It is not clear how many users are willing to invest time and effort verifying certain information they see online. This is further complicated if we consider that some social media users simply want to believe the information as it fits into their political, social, moral or religious beliefs.

In this paper, we present the business processes of two means of combating misinformation on social media. The paper describes Facebook attempt to fight misinformation propagation, followed by the authors own approach known as the ‘Right-click Authenticate’. Finally, this paper concludes with recommendations for improvements as well as research limitations and further research.

### II. MISINFORMATION PROPAGATION AND WAYS TO FIGHT IT

This section provides a description of misinformation propagation, the plans Facebook has in place to combat it, and the proposed approach of ‘Right-click Authenticate’.

#### A. Misinformation propagation

Popular social media networks such as Facebook and Twitter are gaining momentum lately in becoming the first option among users to access news as well as being the most efficient tools for viral marketing nowadays. However, the dominance of these outlets is seen in fact as a double bladed sword, mainly because it can aggravate misinformation propagation

such as the widespread critique that Facebook received about its role in the 2016 U.S. election campaign. Facebook and other social media networks have been accused of not combating misinformation by allowing and encouraging the spread of many fake stories about the candidates. The diversity of social networks and their immense widespread along with the huge number of fake stories shared every moment by users, has made limiting the propagation of misinformation almost impossible on the Web [6]. In 2016, Pew research [5] found that a majority of U.S. adults (62 per cent) seek news via social media and while Facebook may not be the only place where readers get their stories and more importantly where misinformation is diffused. Yet, it is still considered as one of the most prevalent media outlets in the world. Figure 1 demonstrates the percentage of Americans using social media as the main mean of receiving the news.

In [7], the author investigates the structure of Facebook as a ground for spreading misinformation. The paper explains that Facebook algorithms do not differentiate what users' feeds get. Therefore, fake news appears no different than legitimate news. In addition, Facebook provides an environment in which news can be instantly shared hence propagate to reach millions of users. Another evidence of this comes from the post-election Ipsos survey [8] that shows individuals who sought Facebook for news are more likely to classify false news headlines as truthful. Following a media backlash, Facebook has proposed to label unverified or fake news in its news feed without having them removed completely. Moreover, Facebook users who attempt to share stories will be notified with a pop-up message stating that independent fact-checkers disputed its accuracy [11]. In [9], authors reported that Google and Facebook are to ban websites that promote fake news from using its online advertising service.

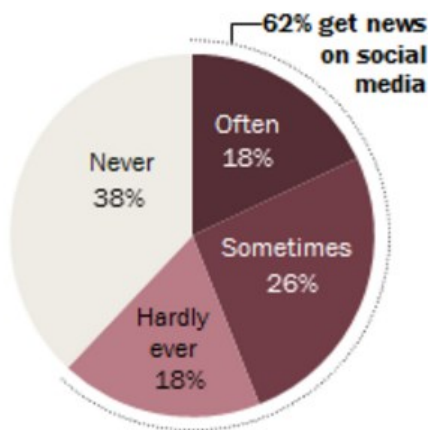

Fig. 1. News use across social media platforms 2016 [5]

### B. Facebook Plans to Combat the Spread of Misinformation

Beyond the spread of misinformation and fake news across social media platforms, the wider issue is how social media companies design their news algorithms according to users' preferences so that they would click more and stay longer on

their websites in the hope of viewing and clicking on advertising banners. In such scenario, readers will be trapped into the same sealed environment that only holds opinions and beliefs similar to theirs, thus creating a shattered society and clusters of reclusive individuals. Facebook dismissed all the human editors in favor of software algorithms in charge of the trending stories section in an attempt to address neutrality and transparency on the topics presented as trending topics [11]. This algorithm removed news posts and their newspaper-like headlines and replaced them by short titles displaying the number of people talking about them. However, the new content could be criticized as being meaningless since readers needed to know on what basis the algorithm decided that a topic is considered trending. Facebook defines itself as a technology platform which conflicts in its attempt to play the role of the news editor, therefore, it leaned toward new methods and developed more intelligent algorithms to filter the newsfeed. An example of that is their anti-click bait algorithm which identifies fake advertising headlines meant to lure readers into clicking a link. Facebook uses this same algorithm to look for a preset of phrases inside the story and scores the likelihood of the story to be a fake story. The higher the clickbait likelihood, the more the algorithm will hide the story and its related pages in users' feeds. Another attempt is Facebook announcing means to report fake news and having third-party checkers verify this news' authenticity [11]. Facebook believes that this approach can help users decide for themselves what to trust and what to share. Facebook authentication process is associated with third-party fact-checking societies that are signatories of Poynter's International Fact Checking Code of Principles [12].

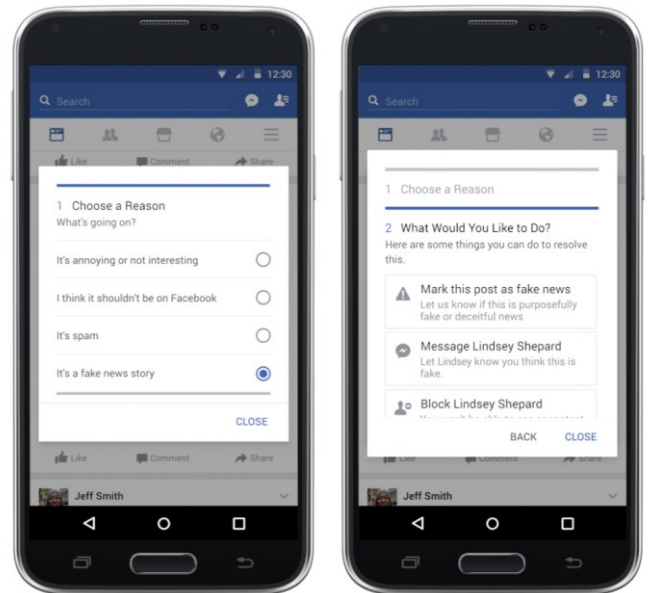

Fig. 2. Flagging stories and actions to be selected [11]

The reports from their community will be used to send stories to these societies so that the user will have different options to mark and report the questionable news, as demonstrated in

figure 2, which then will be forwarded to the third-party for verification - if the user marks this post as fake news. Where the fact-checking organizations classify a story as fake, it will get flagged as disputed and as shown in figure 3, a message will pop-up to notify the user whether the accuracy of the news has been disputed.

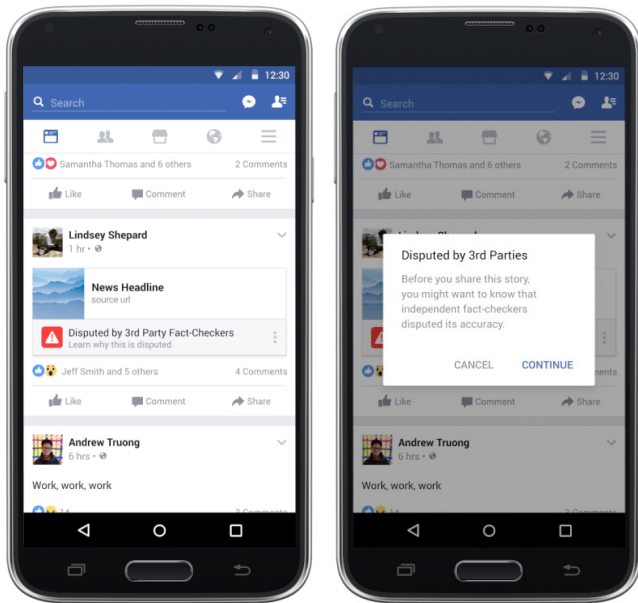

Fig. 3. Disputed by third-party Fact-checkers [11]

C. The 'Right-click Authenticate' approach

As proposed in [13], the authors projected an automated approach dubbed as 'Right-click Authenticate' that would review, rank, and identify misinformation by combining several tools already found online. However, these tools have never been put together in an easily accessible way that would help online users in their pursuit of authentication of the information they view. In this approach, three categories of authentication have been identified [1] textual, [2] imagery, and [3] video misinformation, yet the research focused on the first two, Textual and imagery authentication. In that process, users who are unsure about the content could right-click and select authenticate as conceptualized in figure 4. This approach does not prohibit sharing or trending of misinformation approach, thus satisfying critics who are concerned about suppression of freedom of speech.

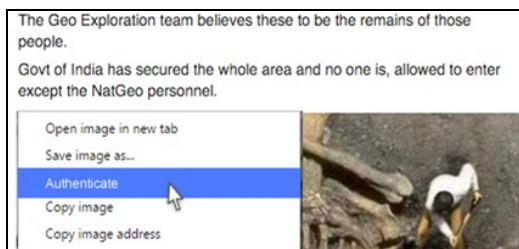

Fig. 4. Conceptualizing a 'Right-click Authenticate' option [13]

Instead, this approach provides a presentation of facts together with editorial in the same format of Wikipedia [13] as shown in figure 5. Demonstration of the method found in [14].

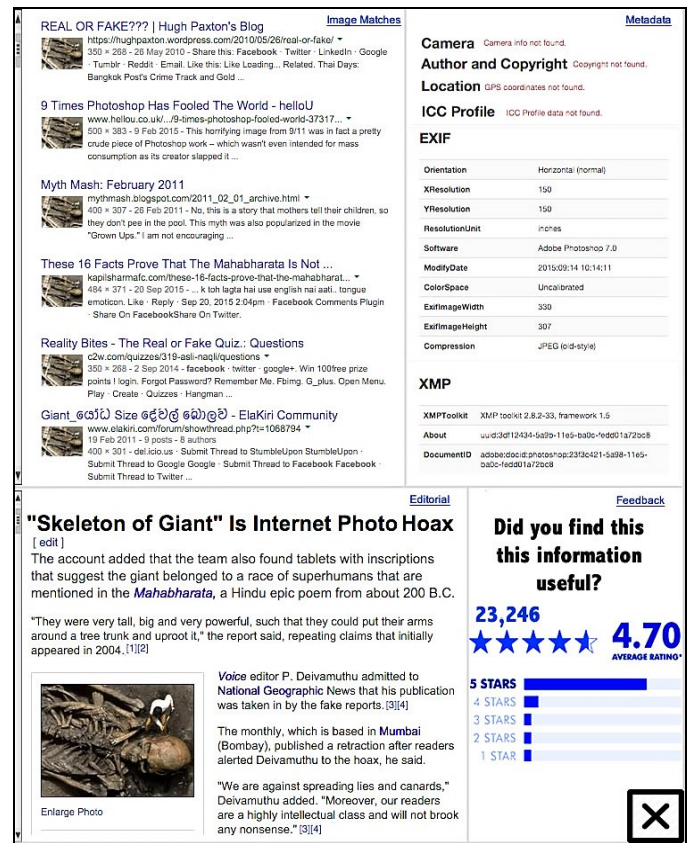

Fig. 5. Conceptualizing 'Right-click Authenticate' results [13]

This approach would also represent an important step to analyze and predict the dynamic trend of misinformation propagation. In [15, 16], the authors provided 2D and 3D simulations involving key variables in simulated social media ecosystem that describes the process of misinformation propagation. These simulations provide an understanding of misinformation propagation and ability to test the efficiency of a control strategy before the actual implementation of the control strategy.

III. METHODOLOGY

To better understand and evaluate the processes involved in authenticating news and information online, the team applied Business Process Modeling and Notation (BPMN) tool followed by a reflective analysis of these processes. There are various notations and languages that are used to model business processes, such as Business Process Model and Notation (BPMN), UML Activity Diagram, UML EDOC Business Processes, IDEF, ebXML BPSS, Activity-Decision Flow (ADF) Diagram, RosettaNet, and Event Process Chains (EPCs). BPMN was introduced in 2004, after several years of efforts at achieving standardization [17]. According to [18],

BPMN is currently established as the most popular notation to model business processes. A key feature of BPMN notation is their ease to read communication tool that provides means to visualize process and open discussion by the variety of stakeholders in the system including business analysts, technical developers, and business people, while still being able to represent complex process semantics [19, 20]. Therefore, BPMN is considered the most robust communication tool between Information Technology (IT) and Business Process (BP) [21]. BPMN also provides a high level of details and allows many extensions for different areas such as security [22], business rules [23], business events [24], and costs [25]. One of the drawbacks of BPMN is that for large systems containing many processes, it can become complex [26]. However, in the case of modelling single processes, such as the case here for authentication news or information, we have determined that BPMN would be the ideal tool to model and analyze the processes. Understanding and analyzing the processes will require reflective analysis. Reflective analysis is sometimes called reflection, critical reflection, or reflexivity, is a research methodology suggested by several researchers [27-30]. This methodology can be viewed as part of a wider method to action research in transformative learning approach [31]. Jennifer Moon is the first researcher to propose this methodology [32]. The purpose

of reflection is to consider a process in more detail in order to reach one or more goals [33]. The input to the reflection process would include a combination of knowledge that the researcher already has in the form of experience, thoughts, ideas, and feelings coupled with the analysis of their findings. As presented in figure 6, this would allow researchers to draw from such process one of several possible outcomes including critical review, decision, or resolution of uncertainty [33]. Therefore, a reflective approach is usually needed where there is no obvious structure of analysis with the input either complicated or unstructured. Diagram design based on literature review findings and experience of the researchers would constitute an example of such unstructured input. On the other hand, critical reflection involves a process of learning from experience, which includes academic research, with the aim of improving professional practice [29]. In this context, reflection is a complex activity which aims to analyze the causes and effects, reflect on person's own experience and the drawing of conclusions concerning future actions, thus resulting in a changed conceptual perspective [34]. Cunliffe in [35] advocated using reflexivity to conduct research by encouraging researchers to go further than questioning the truth claims of others, to question how we as researchers also make truth claims and construct meaning.

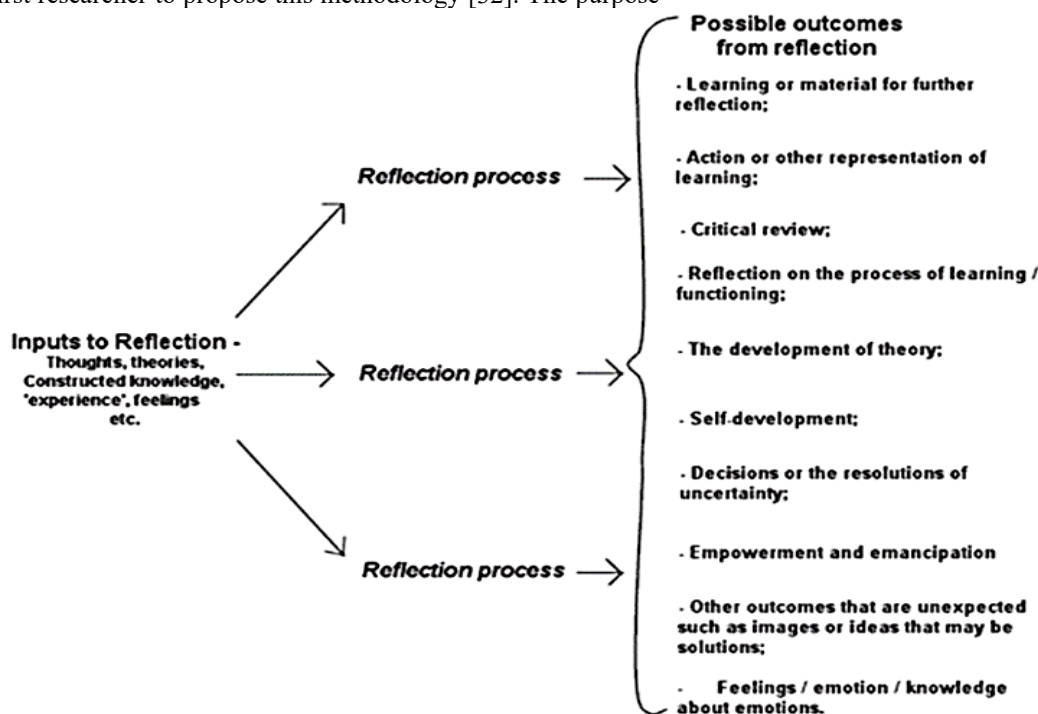

Fig. 6. An input/outcome model of reflection [32]

#### IV. RESEARCH OUTCOME

In this section, the authors provide a BPMN diagram for both approaches and undertake an analysis to identify advantages and limitations of each. Finally, the authors present a reflective analysis on the efficiency and effectiveness of these approaches when compared to each other including lessons to be learned.

##### A. BPMN modeling of Facebook Fake News approach

The press release by Facebook [11] has provided much of the details regarding the process this social media intends to use in order to combat misinformation; this is presented in figure 7. This is then passed to a third-party reviewer who decides if this is a fake piece of news or not. In both cases, the user reporting the news will get some notification. If the article is fake news and the third-party checker confirmed it as fake, then the article is tagged as such.

##### B. BPMN modeling of ‘Right-click Authenticate’

As authors’ of this approach, BPMN model shown in figure 8 is agreed to be sufficiently representative of the ‘Right-click Authenticate’ approach. The process starts with the user right-click to authenticate a post associated with news or the media object associated with this news. The system will check if this piece of news, image, or video has been already authenticated. If an authentication has been done beforehand from previous

requests then the page is retrieved and sent back. If this piece of work has never been authenticated before, the process will retrieve appearances of the news, images, or video in the past and generate a list to return to users without an editorial. Simultaneously, a report is sent to the independent fact-checker, which we called ‘editorial’. Once the editorial is reviewed, be it true or false news, the report is considered complete and saved allowing future authentications to be processed faster.

##### C. Reflection on both approaches

In reflection on the Facebook approach, it is evident that despite Facebook insistence that they will not be involved in the process, Facebook will still be involved by the mere fact that they decide which piece of news is worth reporting. This particular part is not clear and will be subject to debate on impartiality. There is a significant time lapse from the time the news is flagged as fake news having passed through several processes along the way. Users wishing to read why the independent fact-checker disputes this news will need to click and visit the third-party website. Not only this could be faked but also blocked in some countries that intend on allowing the spread of misinformation. The verification process is associated per post. Therefore, a slightly modified version of the post, such as sharing of the same fake picture or video with slightly different title, will require a re-run of the whole process again. Additionally, much of what is shared online has to do with fake images and videos linked to true news. There is no indication how thorough the review will be.

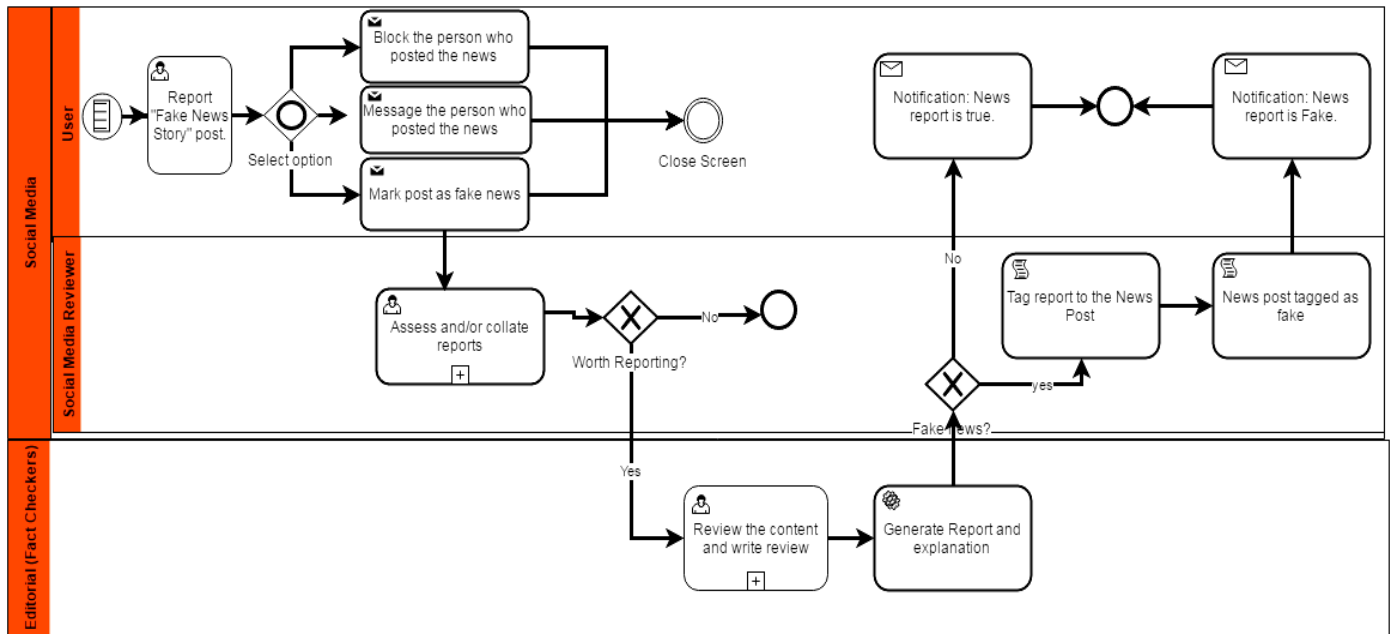

Fig. 7. Facebook ‘Fake News’ approach

Only posts that are flagged as fake are highlighted with no suggestion that authenticated news would be labeled authentic; otherwise, users may continue to flag true news believing it is fake and are in the process of being validated. This results in inefficient running of the processes where an article has been verified to be true but has no flag to show it has been already verified. Finally, the process is limited to this specific social media. This means that it will not proceed to support or help validate misinformation spreading elsewhere. This is a missed opportunity having other social media outlets to repeat this whole process or producing contradictory results. As for the 'Right-click Authenticate' approach, it is evident that the social media has no involvement in the process. The process returns results instantly by showing instances of this news, picture, or video elsewhere online even if the news has not had time to be validated. This could provide early indication if this news is valid or not by showing its sources. The process is efficient to respond instantly if the validation has been done previously. The process operates on a meta-level running from the browser itself. Therefore, once a piece of news, image, or video is deemed as fake, it will appear anytime someone

authenticates on any social media site, app, or otherwise fake news websites; and where the news has been verified to be true, this will appear as well. There are some important limitations to be noted though. The approach does not contain a filtering process to stop abuse of this system and possibly slowing down to a point of denial of service. Unlike Facebook who decides if the item reported is worth reporting, users could abuse this service to authenticate holiday photos, works of literature, or any work that is not in essence news. Another consideration is the effort to authenticate. The Facebook approach suggests that the news will be tagged as fake news without the need to right-click and authenticate. This will be visible for everyone. Moreover, this approach will be restricted to one or few browsers only. Users adamant to follow fake news will simply switch browsers and some countries may go as far as banning such browsers. Finally, both approaches will remain limited in their ability to verify live reporting and breaking news. However, it is evident from this review that the Facebook approach to combating spread of misinformation has some important failings and inefficiencies that the social media needs to address.

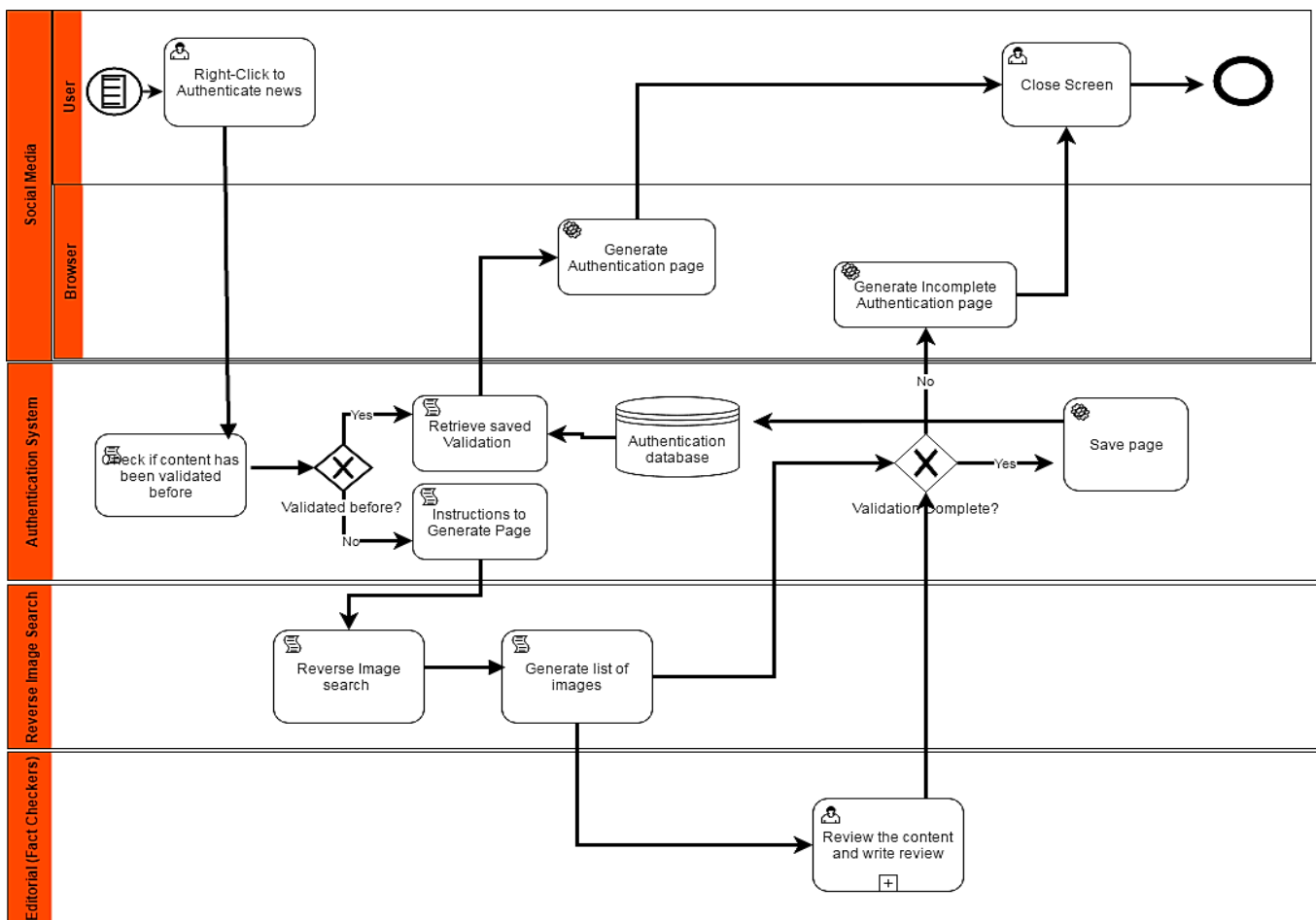

Fig. 8. BPMN 'Right-click Authenticate' approach

## V. RESEARCH LIMITATIONS AND CONCLUSION

The authors acknowledge that the models represent an interpretation that is holistic. Therefore, the BPMN models may include some discrepancies in application and practice. While the Facebook approach has already been put through its early stages of Beta testing, it is likely that the model will be modified and improved overtime. Finally, the assumptions used to model the Right-click Authenticate approach are theoretical. Social media users are accumulating online news at an increasingly rapid pace from unreliable and diverse sources. To deal with the growth and different nature of digital information, authenticate approaches identified in this paper must employ sophisticated techniques for data analysis. Both approaches presented here will have a challenge dealing with news that is being reproduced and rephrased, creating tedious work for third-party which could rapidly increase the waiting time for the news to be verified. However, it is fair to say that the 'Right-click Authenticate' approach and media reverse searches would accelerate the checking that seems to be a critical point in the environment with rapid growth of online content. Furthermore, both approaches will have the challenging tasks of proving how independent and reliable the third-party checkers are. Facebook, Google, Twitter, Youtube and Instagram are some of the many social media websites that are working on combating the spread of misinformation on their social network. Yet, for a problem that is universal, it is logical that the solution has to be universal, independent, and fast while utilizing skills proficiently. To this point, we believe the presented Facebook approach is narrow, restricted, and inefficient.

## REFERENCES

- [1] M.E. McCombs, and D.L. Shaw, "The agenda-setting function of mass media," *Public opinion quarterly*, vol. 36, pp.176-187, 1972.
- [2] A. Rojecki, and S. Meraz, "Rumors and factitious informational blends: The role of the web in speculative politics," *New media & society*, vol. 18, pp.25-43, 2016.
- [3] G. Allpost, and L. Postman, "An analysis of rumor," *Public opinion quarterly*, vol. 10, pp.501-517, 1946.
- [4] J.H. Kuklinski, P.J. Quirk, J. Jerit, D. Schwieder, and R.F. Rich, "Misinformation and the currency of democratic citizenship," *The Journal of Politics*, vol. 62, pp.790-816, 2000.
- [5] E. Shearer, and J. Gottfried, "News Use Across Social Media Platforms," Pew Research Center. Washington, USA, 2016.
- [6] N.P. Nguyen, G. Yan, M.T. Thai, and S. Eidenbenz, "Containment of misinformation spread in online social networks," in *Proceedings of the 4th Annual ACM Web Science Conference*, pp.213-222, 2012.
- [7] Matt Mahoney "The Limits of Fact-Checking Facebook," MIT Technology Review, (December 20, 2016).
- [8] "Ipsos/BuzzFeed Poll - Fake News," December 2016, [Online]. Available at: <http://ipsos-na.com/news-polls/pressrelease.aspx?id=7497> (Last Accessed on 9 February 2017)
- [9] N. Wingfield, M. Isaac, and K. Benner, "Google and Facebook Take Aim at Fake News Sites," *The New York Times*, (November, 2016).
- [10] T. Bucher, "The algorithmic imaginary: exploring the ordinary affects of Facebook algorithms," *Information, Communication & Society*, vol. 20, pp.30-44, 2017.
- [11] A. Mosseri, 2016, "News Feed: Addressing Hoaxes and Fake News - Facebook News Room," [Online] Available at: <http://newsroom.fb.com/news/2016/12/news-feed-fyi-addressing-hoaxes-and-fake-news/> (Last Accessed on 18 January 2017).
- [12] Poynter Inc., 2016, "International Fact-Checking Network fact-checkers' code of principles," [Online] Available at: <http://www.poynter.org/fact-checkers-code-of-principles/> (Last Accessed on 17 January 2017).
- [13] F., Safieddine, W. Masri, and P. Pourghomi, "Corporate responsibility in combating online misinformation," *International Journal of Advanced Computer Science and Applications (IJACSA)*, vol. 7, pp.126-132, 2016.
- [14] "Right-click Authenticate Conceptualization" [Online]. Available at: [http://authenticate.info/conceptualization?right\\_click=true](http://authenticate.info/conceptualization?right_click=true) (Last Accessed on 22 February 2017)
- [15] M. Dordevic, F. Safieddine, W. Masri, and P. Pourghomi, "Combating Misinformation Online: Identification of Variables and Proof-of-Concept Study," in *Conference on e-Business, e-Services and e-Society*, pp. 442-454, Springer International Publishing, September 2016.
- [16] F. Safieddine, M. Dordevic, and P. Pourghomi, "Means of Combating the Spread of Misinformation on Social Media: 3D simulation," In press.
- [17] J.C. Recker, "BPMN modeling—who, where, how and why," *BPTrends*, vol. 5, pp.1-8, 2008.
- [18] G. Aagesen, and J. Krogstie, "Analysis and design of business processes using BPMN," in *Handbook on Business Process Management 1*, pp. 213-235, Springer Berlin Heidelberg, 2010.
- [19] D. Ritter, J. Ackermann, A. Bhatt, and F.O. Hoffmann, "Building a business graph system and network integration model based on BPMN," in *International Workshop on Business Process Modeling Notation*, pp. 154-159, Springer Berlin Heidelberg, November 2011.
- [20] OMG (Object Management Group), 2016, "Business Process Model and Notation Specification" [Online]. Available at: <http://www.omg.org/spec/BPMN/2.0> (Last Accessed on 20 January 2017).
- [21] D. Birkmeier, and S. Overhage, "Is BPMN really first choice in joint architecture development? an empirical study on the usability of BPMN and UML activity diagrams for business users," in *International Conference on the Quality of Software Architectures*, pp.119-134. Springer Berlin Heidelberg, June 2010.
- [22] A. Rodríguez, E. Fernández-Medina, and M. Piattini, "A BPMN extension for the modeling of security requirements in business processes," *IEICE transactions on information and systems*, vol. 90, pp.745-752, 2007.
- [23] M. Milanovic, D. Gašević, and G. Wagner, "Combining rules and activities for modeling service-based business processes," in *Enterprise Distributed Object Computing Conference Workshops*, pp.11-22, IEEE, September 2008.
- [24] G. Decker, A. Grosskopf, and A. Barros, "A graphical notation for modeling complex events in business processes," in *11th International Enterprise Distributed Object Computing Conference*, pp. 27-27, IEEE, October 2007.
- [25] M. Magnani, and D. Montesi, "BPMN: How much does it cost? An incremental approach," in *International Conference on Business Process Management*, pp. 80-87, Springer Berlin Heidelberg, September 2007.
- [26] M. Zur Muehlen, J. Recker, and M. Indulska, "Sometimes less is more: Are process modeling languages overly complex?" in *11th International EDOC Conference*, pp.197-204, IEEE, October 2007.
- [27] C. Morley, "Critical reflection as a research methodology," in *Knowing Differently: Arts-Based and Collaborative Research Methods*, pp.265-280, Nova Science Publishers, Inc., 2008.
- [28] M. Alvesson, and K. Sköldbberg, "Reflexive methodology: New vistas for qualitative research," Sage, Vancouver, 2009.
- [29] J. Fook, "Developing critical reflection as a research method," in *Creative Spaces for Qualitative Researching*, pp.55-64, SensePublishers, 2011.
- [30] C. Morley, "Using critical reflection to research possibilities for change," *British Journal of Social Work*, p.bct004, 2013.
- [31] J. Fook, S. White, and F. Gardner, "Critical reflection: a review of contemporary literature and understandings," *Critical reflection in health and social care*, pp.3-20, 2006.
- [32] J. Moon, 2001, "PDP working paper 4 reflection in higher education learning," [Online], Higher Education Academy, Available at: [www.heacademy.ac.uk/resources.asp](http://www.heacademy.ac.uk/resources.asp) (Last Accessed on 25 January 2017)
- [33] J.A. Moon, "Reflection in learning and professional development: Theory and practice," Routledge, 2013.
- [34] S. Høyurup, and B. Elkjær, "Reflection. Taking it beyond the individual," in *Productive reflection at work*, Routledge, 2006.
- [35] A.L. Cunliffe, "Reflexive inquiry in organizational research: Questions and possibilities," *Human Relations*, 56, pp.983-1003, 2003.