



Laughlin, L., Zhang, C. J., Beach, M., Morris, K., & Haine, J. (2019). Minimum Downlink Band Duplex Isolation Requirements for LTE User Equipment. In *2019 IEEE International Conference on Communications Workshops (ICC Workshops) (IEEE International Conference on Communications Workshops (ICC Workshops))*. Institute of Electrical and Electronics Engineers (IEEE). <https://doi.org/10.1109/ICCW.2019.8756761>

Peer reviewed version

Link to published version (if available):  
[10.1109/ICCW.2019.8756761](https://doi.org/10.1109/ICCW.2019.8756761)

[Link to publication record in Explore Bristol Research](#)  
PDF-document

This is the author accepted manuscript (AAM). The final published version (version of record) is available online via IEEE at <https://ieeexplore.ieee.org/document/8756761>. Please refer to any applicable terms of use of the publisher.

## University of Bristol - Explore Bristol Research

### General rights

This document is made available in accordance with publisher policies. Please cite only the published version using the reference above. Full terms of use are available:  
<http://www.bristol.ac.uk/pure/about/ebr-terms>

# Minimum Downlink Band Duplex Isolation Requirements for LTE User Equipment

L. Laughlin, C. Zhang, M. A. Beach, K. A. Morris and J. L. Haine

Department of Electrical and Electronic Engineering  
University of Bristol, Bristol BS8 1UB, UK  
(Invited Paper)

**Abstract**—Duplexers based on self-interference cancellation can provide substantial transmit-to-receive (Tx-Rx) isolation, whilst being tunable over wide frequency ranges, presenting a promising alternative to fixed-frequency acoustic duplexers commonly used in today’s mobile devices. However, the level of Tx-Rx isolation provided by tunable duplexers is typically lower compared to surface acoustic wave and bulk acoustic wave devices. This paper investigates the impact of reduced isolation on receiver (Rx) noise figure (NF), and quantifies the minimum requirement for Tx-Rx isolation in a long term evolution (LTE) mobile terminal. Tx noise in the Rx band is quantified through measurements taken from a cellular handset power amplifier, for a range of duplex separations and uplink bandwidths, and combined with a simple linear model to calculate the desensitized Rx NF as a function of Tx-Rx isolation. LTE downlink throughput simulations are used to assess the impact of isolation on LTE sensitivity, and establish the minimum isolation required for LTE sensitivity specification compliance. Results show that reduced duplexer isolation leads to substantial desensitization for some duplex separation/bandwidth combinations, however, to achieve the minimum LTE sensitivity requires only 38 dB of isolation in the Rx band; this is achievable using current tunable duplexing technologies.

## I. INTRODUCTION

THE standardization of Third Generation Partnership Project (3GPP) Long Term Evolution (LTE) has seen a dramatic increase in the number of frequency bands in use in cellular systems, with the latest release of LTE specifying >50 bands. Current radio frequency front-end (RFFE) architectures achieve multiband operation through the duplication of transceiver subsystems, requiring multiple transmitters (Tx), receivers (Rx), and power amplifiers (PAs), in order to cover the required frequency ranges. Furthermore, for frequency division duplexing, multiple off-chip surface acoustic wave (SAW) and/or bulk acoustic wave (BAW) duplexers are required, with radio frequency (RF) switches used for band selection. This increases the cost and size of the device, and adds loss in the Tx and Rx paths, limiting the number of bands that can be covered. Because of this, tunable and adaptive radio frequency front-end (RFFE) technologies have recently been the subject of substantial interest, with numerous developments towards the creation of a fully integrated front-end module which can cover wide frequency ranges [1]. Among other advancements, research into tunable duplexing technologies forms a key element of this effort [2]–[10].

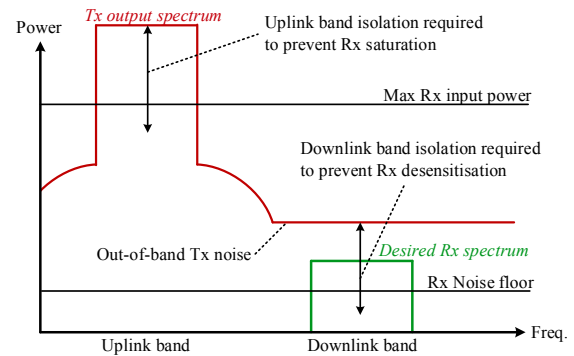

Fig. 1. Typical Tx and Rx spectra in FDD RF front-ends.

Frequency division duplex transceivers require Tx-Rx isolation simultaneously in both the transmit and receiver bands. Tx-band isolation is required to prevent the in-band Tx signal from saturating the receiver, and Rx-band isolation is required to prevent out-of-band Tx noise from desensitizing the receiver. This is shown in Fig. 1 which depicts typical Tx and Rx spectra in an FDD system. An often-quoted figure of merit is that 50 dB of transmit-to-receive (Tx-Rx) isolation is required in both bands, however SAW/BAW devices used in commercial LTE user equipment (UEs) significantly exceed this requirement - acoustic resonator filters for handset applications can provide 60-70 dB of isolation [11].

Electrical balance duplexers (EBDs) implement RF self-interference cancellation based on signal balancing in a hybrid junction. EBDs have received substantial interest as a potential alternative to SAW duplexers [2], [3], [5], [8], [10]. EBDs are potentially well suited to handset applications: they can be implemented within the radio frequency integrated circuit (RFIC), can be tuned over wide frequency ranges, and prototypes have demonstrated the required linearity, power handling, and low insertion loss for cellular applications [3], [5]. However, the isolation bandwidth of the EBD is limited by the impedance balance between the antenna and a tunable balancing impedance. Prototypes in the literature have not achieved sufficient isolation bandwidth to simultaneously cover the uplink and downlink bands, and to address this shortcoming, recent works have investigated combining EBDs with further filtering or cancellation subsystems. Three such architectures [8]–[10] are depicted in Fig. 2. In [8], the EBD

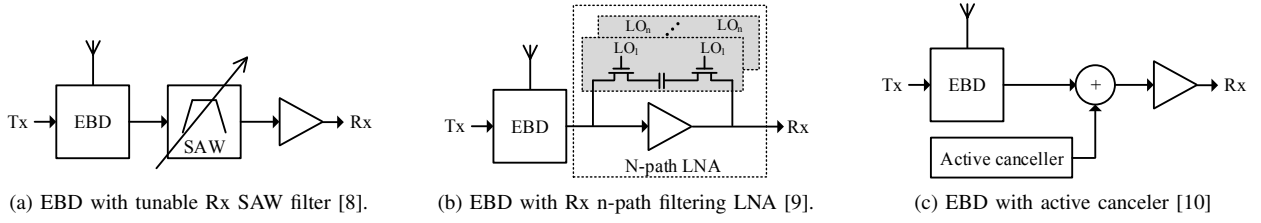

Fig. 2. Three tunable duplexing architectures which utilize an EBD to cancel Tx noise in the Rx band, and combine this with Tx blocker filtering/cancellation.

is used to provide isolation in the downlink band, and a tunable SAW filter in the Rx path provides Tx blocker rejection (Fig. 2a). Likewise, the system reported in [9] (see Fig. 2b) combines an EBD with an N-path filtering low noise amplifier (LNA). In [10], an EBD, operating in the downlink band, is combined with an active RF canceler operating to suppress the Tx blocker in the uplink band (see Fig. 2c). All of these architectures use the EBD to cancel the Tx noise in the Rx band, meaning that the Rx noise figure is heavily dependent on the EBD isolation in the Rx band, which must isolate the Rx input from the Tx noise. However, the Tx-Rx isolation achieved using an EBD may be substantially lower than that provided by a SAW duplexer, typically being only 40-55 dB over a 20 MHz bandwidth.

This paper investigates the impact of reduced downlink band Tx-Rx isolation, quantifying the receiver desensitization and the resulting effect on downlink throughput for typical LTE UEs. A common assumption is that 50 dB of Tx-Rx isolation is required in cellular handset transceivers, and many papers in the literature use this as a pass/fail test to determine whether a novel duplexer design can fulfill the requirements of this application. This paper challenges that assumption, providing quantitative analysis to demonstrate the dependence of receiver noise figure on Tx-Rx isolation, and determining minimum isolation requirements for an LTE handset transceiver. Desensitization in cellular FDD transceivers was previously analyzed in [12], which models non-linearity induced receiver desensitization, and introduces a method of digitally canceling non-linear self-interference (SI) in the receive band. Instead of modeling non-linear SI, this paper simply characterizes the PA spectral regrowth by measuring the Rx-band noise at the PA output, and from this, the impact on Rx sensitivity can be determined using a simple linear signal model. This work only analyzes downlink band isolation requirements, and assumes that adequate Tx-band suppression is achieved (e.g. using filtering or cancellation [8]–[10]).

The remainder of this paper is organized as follows. Section II provides downlink band system noise calculations, developing expressions for the Rx NF as a function of the Tx-Rx isolation and Tx noise. Section III describes hardware measurements from an LTE handset power amplifier (PA), characterizing the Tx noise for different uplink bandwidths and duplex separations, and combining this with the theoretical analysis to determine practical isolation requirements for LTE user equipment (UE) devices. Section IV presents LTE downlink throughput simulations, determining the throughput as a function of Tx-Rx isolation, and establishes the minimum isolation for LTE sensitivity specification compliance. Section

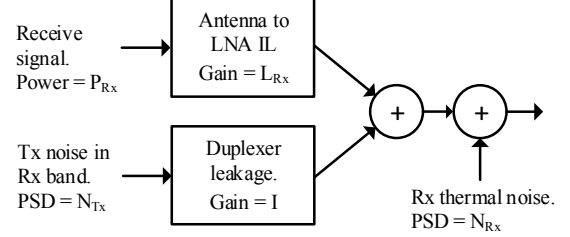

Fig. 3. Downlink band signal model with thermal noise and desensitization noise.

V presents a generalized theory for calculating the minimum isolation requirement, and Section VI concludes this paper.

## II. DOWNLINK BAND SYSTEM NOISE CALCULATIONS

From the definition of the noise factor, the receiver noise factor,  $F_{Rx}$ , can be written as

$$F_{Rx} = \frac{N_{Rx}}{kT} \quad (1)$$

where  $N_{Rx}$  is the receiver noise power spectral density (PSD),  $k$  is the Boltzmann constant and  $T$  is the input thermal noise temperature in degrees Kelvin (e.g. 290 K). Assuming the Tx noise and the Tx-Rx isolation are frequency invariant, the PSD of the desensitizing noise due to Tx leakage,  $N_{TxL}$ , can be calculated as

$$N_{TxL} = IN_{Tx} \text{ W Hz}^{-1} \quad (2)$$

where  $N_{Tx}$  is the PSD of the Tx noise in the Rx band, and  $I$  is the Tx-Rx gain (i.e. the leakage channel through the EBD). The noise due to Tx leakage adds to the thermal noise at the receiver (see Fig. 3), and thus the total noise power spectral density of the desensitized receiver,  $N_{RxD}$  is given by

$$\begin{aligned} N_{RxD} &= N_{Rx} + N_{TxL} \\ &= N_{Rx} + IN_{Tx} \text{ W Hz}^{-1}. \end{aligned} \quad (3)$$

From (1), the noise factor of the desensitized receiver,  $F_{RxD}$ , can therefore be expressed as

$$\begin{aligned} F_{RxD} &= \frac{N_{RxD}}{kT} \\ &= \frac{N_{Rx} + IN_{Tx}}{kT} \end{aligned} \quad (4)$$

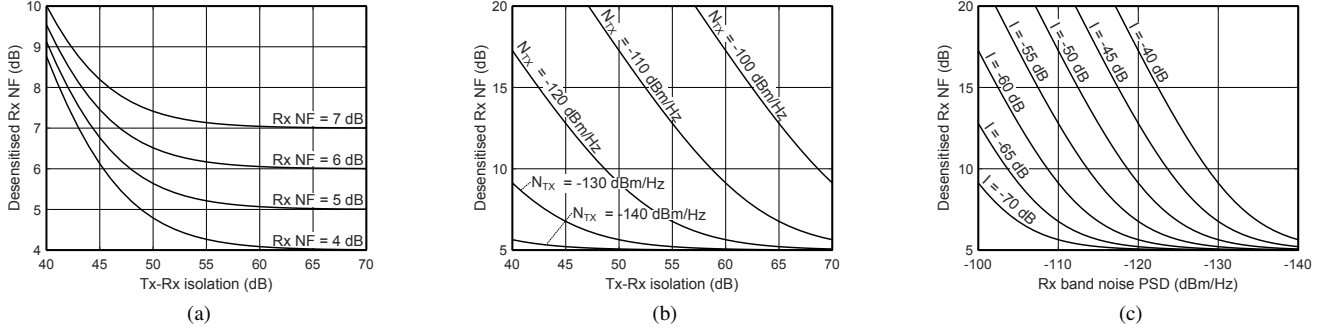

Fig. 4. (a) Calculated noise figure of desensitized receiver for an Rx band Tx noise PSD of  $-130 \text{ dBm Hz}^{-1}$  for receiver noise figures (undesensitized) of 4-7 dB, as Tx-Rx isolation is varied. (b) Calculated noise figure of desensitized receiver for an undesensitized Rx noise figure of 5 dB, and for different Rx band Tx noise PSDs between  $-100$  and  $-140 \text{ dBm Hz}^{-1}$ , as Tx-Rx isolation is varied. (c) Desensitized Rx NF as a function of Rx band noise PSD, for different levels of isolation.

and the noise figure of the desensitized receiver at the LNA input,  $\text{NF}_{RxD}$ , is therefore

$$\begin{aligned}
 \text{NF}_{RxD} &= 10 \log_{10}(F_{RxD}) \\
 &= 10 \log_{10}\left(\frac{N_{Rx} + IN_{Tx}}{kT}\right) \\
 &= 10 \log_{10}(N_{Rx} + IN_{Tx}) - 10 \log_{10}(kT) \\
 &= 10 \log_{10}(N_{Rx} + IN_{Tx}) + 204 \quad (5)
 \end{aligned}$$

where  $N_{Rx}$  and  $N_{Tx}$  are expressed in  $\text{W Hz}^{-1}$  and the temperature is taken to be 290 K. To calculate the desensitized Rx NF referred to the antenna port,  $\text{NF}_{AntD}$ , the antenna-to-LNA insertion loss must be added to this, such that

$$\text{NF}_{AntD} = 10 \log_{10}(N_{Rx} + IN_{Tx}) + 204 + L_{RxdB} \quad (6)$$

where  $L_{RxdB}$  is the antenna-to-LNA insertion loss in dB, calculated as  $L_{RxdB} = -10 \log_{10}(L_{Rx})$ , where  $L_{Rx}$  is the antenna-to-LNA gain.

#### A. Impact on receiver noise figure

The theoretical impact of the Tx leakage on the Rx NF has been investigated, using (6) to calculate the desensitized NF for a range of transceiver system parameters. The parameter ranges used in this analysis are given in Table I. Fig. 4 plots the desensitized noise figure  $\text{NF}_{AntD}$ , as functions of Tx-Rx isolation and Tx noise PSD across this parameter range. Fig. 4(a) plots the desensitized noise figure as a function of Tx-Rx isolation for an Rx band noise PSD of  $-130 \text{ dBm Hz}^{-1}$  (a typical design value [4], [10]) and antenna referred Rx NFs of 4-7 dB. Results show that, for a Rx band Tx noise PSD of  $-130 \text{ dBm Hz}^{-1}$ , 50 dB is adequate to keep desensitization below 1 dB even for the lowest Rx NF of 4 dB. However, with only 40 dB of isolation, desensitization is not catastrophic, leading to desensitized Rx NFs of 8-10 dB. Fig. 4(b) shows the desensitized Rx noise figure as a function of Tx-Rx isolation for different values of Rx band noise PSD. These results quantify the substantial desensitization that occurs for higher Tx noise PSDs, showing that, as would be expected, much higher levels of isolation, e.g. 60-70 dB, are required to maintain an acceptable Rx NF when the Tx noise is higher. Likewise, Fig. 4(c) plots the antenna referred desensitized Rx NF as a function of the PSD of the Tx noise

TABLE I  
RANGE OF VALUES USED IN THIS ANALYSIS FOR RECEIVER NOISE PSD (WITHOUT DESENSITIZATION), TX NOISE PSD IN THE RX BAND, AND TX-RX ISOLATION (I.E. DUPLEXER LEAKAGE).

Parameter	Minimum	Maximum
Rx noise PSD (LNA), $N_{Rx}$	$-173 \text{ dBm Hz}^{-1}$ (NF = 1 dB)	$-170 \text{ dBm Hz}^{-1}$ (NF = 4 dB)
Antenna-LNA IL, $L_{RxdB}$	3 dB	3 dB
Antenna referred NF (without desensitization)	4 dB	7 dB
Tx noise PSD in Rx band, $N_{Tx}$	$-140 \text{ dBm Hz}^{-1}$	$-100 \text{ dBm Hz}^{-1}$
Tx-Rx Isolation, $I^{-1}$	40 dB	70 dB

in the Rx band for different levels of Tx-Rx isolation, drawing similar conclusions. From these results we may conclude that the duplexers with lower isolation may lead to substantial desensitization, however this depends heavily upon the level of Tx noise in the Rx band. The Tx noise PSD in the Rx band is quantified for a typical LTE UE in the following section.

### III. IMPACT OF TX NOISE IN LTE USER EQUIPMENT

This section presents measurements of the Tx noise for a LTE UE type system in order to correctly parametrize the theoretical analysis presented above, thereby determining the impact reduced isolation in LTE UE systems.

#### A. Rx band noise measurements for LTE UE power amplifier

To determine typical values for the Tx-noise power in the Rx-band measurements have been performed to characterize Rx band Tx-noise PSD at the output of a commercial LTE UE power amplifier (PA). Fig. 5 shows the experimental setup. A National Instruments USRP-2942R is used to generate an LTE uplink signal, which is then filtered and fed to the PA. Pre-PA filtering is required as the USRP Tx output thermal noise floor is substantially higher than that of a typical UE radio frequency integrated circuit (RFIC). A 3<sup>rd</sup> order tunable microstrip interdigital filter, manually tuned using mechanically tunable capacitors, and fabricated using FR4, is used

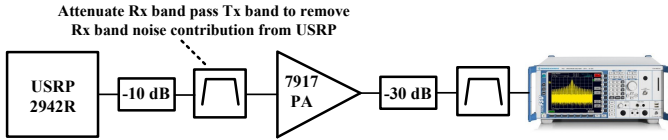

Fig. 5. Hardware setup for measuring Tx noise in the Rx band.

to compensate for this noise prior to the PA. This is tuned to reduce the USRP output noise to a level which is representative of a cellular UE RFIC:  $-154$  dBm/Hz at a 55 MHz offset from the carrier frequency [4]. A 10 dB attenuator is also included between the USRP and the filter to mitigate poor output impedance matching of the USRP Tx output. An LTE band 28 (700 MHz) UE PA is used (RFMD RF7917), operated at its maximum rated output power of 27 dBm. A 30 dB attenuator is included at the output of the PA to sink Tx power and protect the measurement equipment. The Tx noise PSD is measured using a National Instruments PXIe-5644R vector signal transceiver running in spectrum analyzer mode. Due to the limited dynamic range of this instrument, the in-band Tx signal must be attenuated to allow measurement of the Tx noise in the Rx band. To achieve this, a SAW filter (a TDK B8538 LTE band 28 duplexer, passband: 758-788 MHz) is used to pass the noise in the Rx frequency range, and attenuate the uplink signal in the Tx band. The passband insertion loss of this filter was measured to be 1.8 dB, and a corresponding offset was added to the measurements to remove the effect of this loss (and the 30 dB attenuator) on the measurement. The uplink signal used was a single carrier frequency division multiple access (SC-FDMA) signal with quadrature phase shift keying (QPSK) modulation, and uplink bandwidths of 5 MHz, 10 MHz, and 20 MHz were tested. The receive frequency was fixed at 768 MHz, and the duplex separation was varied by changing the Tx carrier frequency ( $f_{Tx}$ ). Two duplex separations were tested: a wide separation, 120 MHz ( $f_{Tx} = 648$  MHz), and a narrow separation, 55 MHz ( $f_{Tx} = 713$  MHz).

### B. Measurement results

The measured PSD of the Tx noise at the Rx carrier frequency are shown in Table I. At the wide duplex separation, the Tx noise is around  $-132$  dBm Hz $^{-1}$ , and shows little dependence on the uplink bandwidth; this shows that, at wide duplex separations, the noise floor is dominated by thermal noise. However, for the narrow duplex separation the Tx noise PSD is highly dependent on the uplink bandwidth, with the 20 MHz uplink bandwidth resulting in a  $>23$  dB increase in Tx noise PSD compared to the 5 MHz uplink bandwidth, this being due to PA spectral regrowth.

Fig. 6 shows the theoretical desensitized antenna referred noise figure as a function of Tx-Rx isolation calculated using the measured values for Tx noise PSD, thereby quantifying desensitization and isolation requirements for LTE UE devices. For the narrow duplex separation with 5 MHz bandwidth, and all configurations with wide duplex separations, 45 dB isolation is sufficient to achieve an 6-7 dB NF, which may be acceptable for cellular applications. However for the 10

TABLE II  
MEASURED TX NOISE PSD IN RX BAND AT PA OUTPUT. OUTPUT POWER IS 23 dBm. RX BANDWIDTH IS 20 MHz AND THE REPORTED NOISE PSD IS THE AVERAGE PSD ACROSS THE RX BAND.

Duplex sep.	Uplink BW	Rx noise PSD
120 MHz	5 MHz	$-132.1$ dBm Hz $^{-1}$
	10 MHz	$-132.5$ dBm Hz $^{-1}$
	20 MHz	$-132.4$ dBm Hz $^{-1}$
55 MHz	5 MHz	$-131.4$ dBm Hz $^{-1}$
	10 MHz	$-124.4$ dBm Hz $^{-1}$
	20 MHz	$-107.9$ dBm Hz $^{-1}$

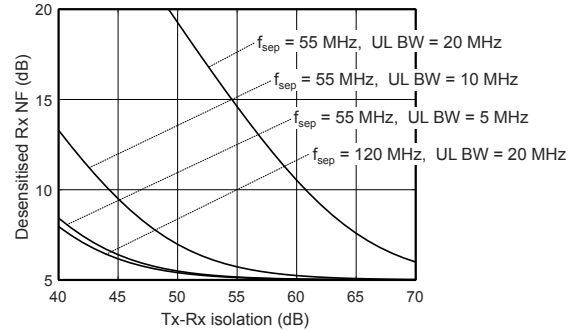

Fig. 6. Calculated desensitized antenna referred NF as a function of isolation using measured Tx noise PSD values for various duplex separations and uplink bandwidths.

MHz and 20 MHz uplink bandwidths with narrow duplex separation, the isolation requirements are much higher, and for 20 MHz uplink bandwidth, some 65-70 dB would be required to achieve an acceptable NF.

### IV. LTE DOWNLINK SENSITIVITY

The sensitivity test cases as defined in LTE [13, Section 7.3] specify that the UE must achieve a throughput of  $>95\%$  of the maximum throughput for the specified physical layer configurations at the specified Rx power levels. Thus, to simulate the sensitivity test case requires the entire LTE physical layer, including channel coding and hybrid automatic repeat request (HARQ).

The MATLAB LTE system toolbox, which implements all of the physical layer DSP, coding, and physical layer protocols in LTE, was used to analyze the throughput of an LTE downlink channel subject to receiver thermal noise and receiver desensitization from Tx noise (both modeled as an AWGN channel), and the signal and noise powers are calculated according to the signal model presented in section II (see Fig. 3). The noise power is calculated according to the three noise PSD values measured for the 55 MHz duplex separation as described in the previous section. The receive power at the antenna port is set to  $-94$  dBm, which is the reference sensitivity receive power for 20 MHz downlink bandwidths for unrelaxed sensitivity testcases [13]. The LTE downlink channel parameters are those specified for 20-MHz LTE downlink sensitivity test cases (see [13, Section 7.3] and [13, Table A.3.2-1]): the downlink channel occupies 100 LTE resource blocks, the downlink signal is an orthogonal

frequency division multiplexing QPSK signal, the code rate is 1/3, and the radio channel is static and frequency flat. The simulated throughput is calculated as the Tx-Rx isolation is varied from 30-70 dB.

### A. Results

Fig. 7 plots the simulated throughput against Tx-Rx isolation for the simulated configurations. Results show large differences in the level of isolation required to achieve -94 dBm Rx sensitivity, depending on the uplink bandwidths. Only 41.7 dB isolation is required to achieve >95% throughput with a 5 MHz uplink bandwidth, increasing to 48.6 dB for a 10 MHz uplink bandwidth, and very high Tx-Rx isolation of 65.0 dB is required for the 20 MHz uplink bandwidth. Considering this high isolation requirement, it is clear that a state-of-the-art in acoustic duplexers achieving >65 dB Rx-band isolation would be required to prevent desensitization in this corner case of maximum Tx power, maximum Tx bandwidth, and narrow separation. However, it is pertinent to note that the LTE sensitivity specification does not require this type of configuration to be tested. For LTE band 28, the 20 MHz downlink sensitivity testcase specifies an uplink bandwidth of only 5 MHz, occupying the upper 5 MHz of the 20 MHz uplink band (which gives an effective duplex separation of 47.5 MHz) thereby reducing the Tx noise and relaxing the isolation requirement [13, Section 7.3]. Using the measurement setup described in Section III, the Tx noise PSD at the Rx frequency was measured as -129.9 dBm Hz<sup>-1</sup> for this bandwidth/separation configuration. Furthermore, for band 28 with 20 MHz downlink bandwidth, the testcase is further relaxed by increasing the receiver sensitivity power requirement to -91 dBm. To determine the minimum isolation requirement for this LTE sensitivity testcase, the throughput simulation was also run using these parameters, and the results (see Fig. 7) show that only 37.8 dB Tx-Rx isolation is required to meet this sensitivity specification. Thus, although duplexers with reduced Rx band isolation would result in performance degradation for some bandwidths/duplex separations as compared to SAW duplexers, the LTE specification can tolerate quite substantial desensitization, especially for the narrow duplex separation where relaxations are applied. Thus, transceivers with reduced duplex isolation can still comply with the specification, and designers of future mobile handsets may choose to trade receiver sensitivity for tunability.

## V. GENERALIZED MINIMUM ISOLATION REQUIREMENT

The analysis presented above has determined the minimum isolation requirement for a particular transceiver (i.e. for the measured Tx noise PSD values, and typical values assumed for the LNA NF and Rx insertion loss). However, by observing that the Rx reference sensitivity requirement can be translated to a maximum noise figure requirement, this analysis can be further generalized. The SNR can be written as the ratio of the power spectral densities of the signal to the noise, such that

$$\text{SNR} = \frac{S_{Rx}}{N_{Rx}} \quad (7)$$

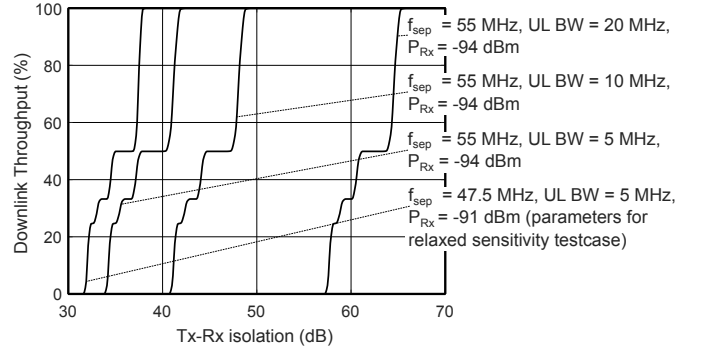

Fig. 7. Simulated downlink throughput as a function of Rx band Tx-Rx isolation for different Tx bandwidths, duplex separations, and Rx powers.

where  $S_{Rx}$  is the average PSD of the receive signal at the antenna, and  $N_{AntD}$  is the noise PSD of the desensitized Rx referred to the antenna. A minimum SNR can therefore be specified in terms of a receive PSD and maximum desensitized Rx noise PSD

$$\text{SNR}_{min} = \frac{S_{Rx}}{N_{AntD,max}} \quad (8)$$

This can be re-arranged to give

$$N_{AntD,max} = \frac{S_{Rx}}{\text{SNR}_{min}} \quad (9)$$

and the maximum noise figure is therefore calculated as

$$NF_{AntD,max} = \log_{10}\left(\frac{S_{Rx}}{\text{SNR}_{min}}\right) + 204. \quad (10)$$

For the downlink transmission configuration specified for sensitivity testing, simulations show that the minimum SNR requirement for >95% is -0.1 dB. According to (10), this corresponds to a maximum desensitized antenna referred Rx noise figure of  $N_{AntD,max} = 7.3$  dB for unrelaxed testcases (e.g. the a 20 MHz downlink sensitivity requirement of -94 dBm), and increases for relaxed testcases, for example increasing to  $N_{AntD,max} = 10.4$  dB when the reference sensitivity requirement is relaxed to -91 dBm.

Equation (6), can be re-written in terms of maximum antenna referred noise figure,  $NF_{AntD,max}$ , by substituting  $NF_{AntD} = NF_{AntD,max}$  and maximum Tx-Rx gain (i.e minimum Tx-Rx isolation),  $I_{max}$ , by substituting  $I = I_{max}$ , such that

$$NF_{AntD,max} = 10 \log_{10}(N_{Rx} + I_{max}N_{Tx}) + 204 + L_{RxdB}. \quad (11)$$

Rearranging this to make  $I_{max}$  the subject (in dB) yields

$$I_{max,dB} = 10 \log_{10} \left( \frac{F_{AntD,max}L_{Rx} - F_{Rx}}{N_{Tx}} \right) + 204. \quad (12)$$

where  $I_{max,dB} = 10 \log_{10}(I_{max})$  is the maximum allowable Tx-Rx gain in order to achieve the maximum allowable noise figure  $NF_{AntD,max}$  for LTE sensitivity compliance,  $F_{AntD,max} = 10^{NF_{AntD,max}/10}$  is the corresponding maximum allowable antenna referred noise factor, and all other variables are as previously defined.

Using (12), the minimum Tx-Rx isolation required to

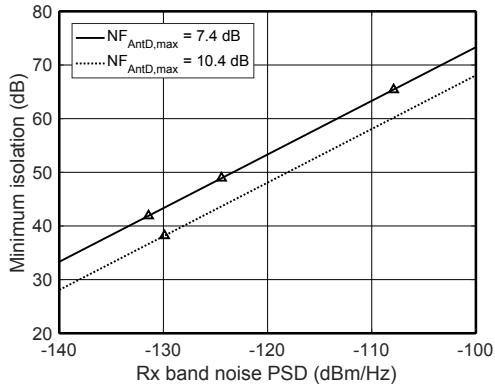

Fig. 8. Minimum required isolation as a function of Rx-band noise PSD at the PA output for an LNA NF of 2 dB and Rx insertion loss of 3 dB, and maximum desensitized NF of 7.4 dB (normal LTE sensitivity requirement) and 10.4 dB (LTE sensitivity requirement with 3 dB relaxation). The markers correspond to the Rx-band noise PSD values used for the simulations in Fig. 7, and the corresponding isolation values required to achieve >95% throughput show close agreement.

achieve LTE sensitivity can be calculated as a function of LNA noise figure, Rx insertion loss, and Tx noise in the Rx band. The maximum desensitized noise factor,  $F_{AntD,max}$  depends on the LTE testcase, with maximum noise figure values ( $NF_{AntD,max}$ ) being between 7.4 dB for no sensitivity relaxation, and 10.9 dB for the maximum sensitivity relaxation of 3.5 dB, as applied for LTE band 25 sensitivity testing [13, Section 7.3]. Fig. 8 shows minimum Tx-Rx isolation required to achieve LTE sensitivity for a range of Rx band noise PSD values and using the same receiver parameters as used in section IV (2 dB LNA NF, 3 dB Rx insertion loss), for unrelaxed testcases (maximum desensitized NF of 7.4 dB), and testcases with 3 dB relaxation (maximum desensitized NF of 10.4 dB). As would be expected, the required isolation is linearly proportional to the Rx-band noise. For an unrelaxed sensitivity testcase ( $NF_{AntD,max} = 7.4$  dB), the commonly applied 50 dB isolation criterion would allow for a maximum Rx-band noise PSD at the PA output of -123 dBm/Hz. Unrelaxed testcases correspond to wide duplex separations, however the Rx band noise PSD measurements (Table II) show that for wide separations, the Rx band noise is typically only <-132 dBm/Hz. This is well below the -123 dBm/Hz maximum which could be tolerated with 50 dB isolation, again demonstrating that lower isolation is permissible.

## VI. CONCLUSIONS

Tunable duplexers, such as those based on self-interference cancellation, may provide lower isolation compared to acoustic filter based duplexers, but can be tuned over wide frequency ranges to cover a large number of bands. This paper has studied the impact of reduced Tx-Rx isolation on Rx noise figure, and quantified minimum isolation requirements in the downlink band for LTE user equipment. The Rx NF has been calculated as a function of Tx noise at the Rx frequency, Tx-Rx isolation, and receiver parameters, and the theoretical analysis has been parametrized using measurements of the Tx noise produced by an LTE handset PA. This analysis demonstrates

that reducing the isolation can have a severe detrimental impact on the Rx NF for configurations with narrow duplex separations and wide uplink bandwidths, but far less impact with narrower uplink bandwidths, due to the lower out-of-band Tx emissions.

LTE downlink throughput simulations have been used to establish minimum isolation requirements for LTE UEs. Results show that high isolation is needed in order to maintain receiver sensitivity for configurations with wide uplink bandwidths and narrow duplex separations, however the LTE sensitivity specification does not require this. For LTE band 28, and using a measured value of -129.9 dBm/Hz Tx noise PSD at the Rx band, UE Rx sensitivity specification compliance can be achieved with only ~38 dB of Tx-Rx isolation in the Rx band.

The LTE sensitivity testcases, defined in terms of throughput, can be abstracted to a maximum noise figure requirement. This can be used to provide a generalized expression which allows the minimum isolation required for LTE sensitivity specification compliance to be calculated as a function of LNA NF, Rx insertion loss, and Tx noise PSD in the Rx band.

## REFERENCES

- [1] J. Tsutsumi, *et al.*, "Cost-Efficient, High-Volume Transmission: Advanced Transmission Design and Architecture of Next Generation RF Modems and Front-Ends," *IEEE Microw. Mag.*, vol. 16, no. 7, pp. 26–45, aug 2015.
- [2] M. Mikhemar, H. Darabi, and A. A. Abidi, "A Multiband RF Antenna Duplexer on CMOS: Design and Performance," *Solid-State Circuits, IEEE J.*, vol. 48, no. 9, pp. 2067–2077, 2013.
- [3] S. H. Abdelhalem, P. S. Gudem, and L. E. Larson, "Hybrid Transformer-Based Tunable Differential Duplexer in a 90-nm CMOS Process," *Microw. Theory Tech. IEEE Trans.*, vol. 61, no. 3, pp. 1316–1326, 2013.
- [4] P. Bahramzy, *et al.*, "A Tunable RF Front-End With Narrowband Antennas for Mobile Devices," *IEEE Trans. Microw. Theory Tech.*, vol. 63, no. 10, pp. 3300–3310, oct 2015.
- [5] B. van Liempd, *et al.*, "A +70-dBm IIP3 Electrical-Balance Duplexer for Highly Integrated Tunable Front-Ends," *IEEE Trans. Microw. Theory Tech.*, pp. 1–13, 2016.
- [6] M. A. Khater, *et al.*, "A tunable 0.861.03 GHz FDD wireless communication system with an evanescent-mode duplexer and a self-interference-cancelling receiver," in *2017 IEEE MTT-S Int. Microw. Symp.* IEEE, jun 2017, pp. 376–379.
- [7] L. Calderin, *et al.*, "Analysis and Design of Integrated Active Cancellation Transceiver for Frequency Division Duplex Systems," *IEEE J. Solid-State Circuits*, vol. 52, no. 8, pp. 2038–2054, aug 2017.
- [8] B. van Liempd, *et al.*, "Adaptive RF Front-Ends Using Electrical-Balance Duplexers and Tuned SAW Resonators," *IEEE Trans. Microw. Theory Tech.*, pp. 1–8, 2017.
- [9] G. Qi, *et al.*, "A SAW-Less Tunable RF Front End for FDD and IBFD Combining an Electrical-Balance Duplexer and a Switched-LC N-Path LNA," *IEEE J. Solid-State Circuits*, vol. 53, no. 5, pp. 1431–1442, may 2018.
- [10] L. Laughlin, *et al.*, "Tunable Frequency-Division Duplex RF Front End Using Electrical Balance and Active Cancellation," *IEEE Trans. Microw. Theory Tech.*, vol. 66, no. 12, pp. 5812–5824, dec 2018.
- [11] T. Bauer, *et al.*, "A Bright Outlook for Acoustic Filtering: A New Generation of Very Low-Profile SAW, TC SAW, and BAW Devices for Module Integration," *IEEE Microw. Mag.*, vol. 16, no. 7, pp. 73–81, aug 2015.
- [12] A. Kiayani, *et al.*, "Modeling and Joint Mitigation of TX and RX Nonlinearity-Induced Receiver Desensitization," *IEEE Trans. Microw. Theory Tech.*, vol. 65, no. 7, pp. 2427–2442, jul 2017.
- [13] 3GPP, "Evolved Universal Terrestrial Radio Access (E-UTRA); User Equipment (UE) conformance specification Radio transmission and reception. Part 1: Conformance Testing," 3rd Generation Partnership Project (3GPP), TS 36.521-1 v13.0.0, 12 2015.