

Open Research Online

The Open University's repository of research publications and other research outputs

Isolation and analysis of genes involved in mouse gonad development

Thesis

How to cite:

Siggers, Pamela Helen (2005). Isolation and analysis of genes involved in mouse gonad development. PhD thesis The Open University.

For guidance on citations see [FAQs](#).

© 2005 Pamela Siggers

Version: Version of Record

Copyright and Moral Rights for the articles on this site are retained by the individual authors and/or other copyright owners. For more information on Open Research Online's data [policy](#) on reuse of materials please consult the policies page.

oro.open.ac.uk

Isolation and Analysis of Genes involved in Mouse Gonad development

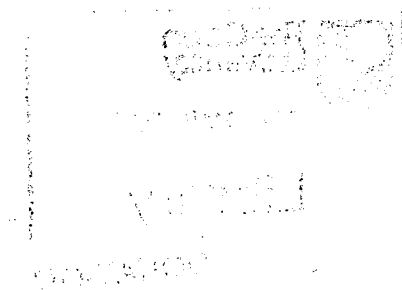

Pamela Siggers, Bsc, Msc

A thesis submitted in partial fulfilment of the requirements of the
Open University for the degree of Doctor of Philosophy

Life Sciences

October 2004

Medical Research Council, Mammalian Genetics Unit, Harwell

Submission date: 16 November 2004
Award date: 14 March 2005

ProQuest Number:27527255

All rights reserved

INFORMATION TO ALL USERS

The quality of this reproduction is dependent upon the quality of the copy submitted.

In the unlikely event that the author did not send a complete manuscript and there are missing pages, these will be noted. Also, if material had to be removed, a note will indicate the deletion.



ProQuest 27527255

Published by ProQuest LLC (2019). Copyright of the Dissertation is held by the Author.

All rights reserved.

This work is protected against unauthorized copying under Title 17, United States Code
Microform Edition © ProQuest LLC.

ProQuest LLC.
789 East Eisenhower Parkway
P.O. Box 1346
Ann Arbor, MI 48106 – 1346

Isolation and Analysis of Genes involved in Mouse Gonad Development

Pamela Siggers

Abstract:

Sex determination in the mammalian embryo is initiated when the bipotential gonad becomes committed to either the testicular or ovarian fate, depending on the presence or absence of the sex determining gene *Sry*. In the presence of *Sry* the gonad forms a testis. *Sry* is expressed in the supporting cells of the gonad and results in the differentiation of Sertoli cells. This process instigates a cascade of gene expression leading to testis cord development and masculinisation of the embryo. Many steps are required for this process. Little is known about these steps or how they are co-ordinated after the expression of *Sry*. In the absence of *Sry* the gonad develops into an ovary. Again little is known about ovarian development as the majority of research in this field has focused on the development of the testis. The aim of this project was therefore to find new genes, in new functional classes involved in the development of male and female gonads.

The starting point of this project was the use of wholemount *in situ* hybridisation analyses to validate the expression of candidate sexual development genes. These had been shown to be expressed in a sexually dimorphic manner in the developing gonad using microarrays. Two genes, *Gata2* and *Vanin-1*, were chosen for further study. *Gata2* is expressed in the germ cells of the developing ovary and is currently the only gene whose expression is found to be female-specific during gonadogenesis. *Vanin-1* is a GPI-anchored cell surface molecule thought to be involved in the migration of bone marrow cells to the thymus. Cell migration is an important feature of testis cord development, therefore *Vanin-1* could play similar role in this process. It is expressed in the developing male gonad prior to overt testis cord formation and in the Sertoli cells once they form. Organ culture studies with an anti-Vanin-1 monoclonal antibody showed that cord formation in XY gonads could be blocked *in vitro*. However, studies of the *Vanin-1* *-/-* mouse revealed no overt abnormalities in testis development.

Table of contents

Chapter 1: Introduction	1
1.1 Mammalian sex determination and sexual development.....	2
1.2 Sexual development in the mouse.....	4
1.2.1 Origin and development of the gonads	5
1.2.2 Sex determination.....	8
1.2.3 Sexually dimorphic development of the mesonephros.....	9
1.2.4 The importance of the supporting cell lineage in male sexual development	9
1.2.5 The importance of mesonephric cell migration in male sexual development	12
1.3 Molecular genetics of male gonad development	13
1.3.1 Early acting genes.....	13
1.3.2 Sry and Sox9.....	15
1.3.3 Other key genes.....	18
1.4 Ovarian development.....	22
1.4.1 Molecular genetics of ovarian development.....	23
1.5 Unanswered questions	25
1.6 The search for new genes involved in sexual development.....	27
1.6.1 Criteria for screening for new genes	27
1.6.2 DNA microarray technology can be used for rapid high through- put screening.....	28
1.6.3 Organ culture studies can be used in further analysis	31
1.7 Aim of this project	34
Chapter 2: Materials and Methods	35
2.1 Standard solutions.....	36
2.2 NMUR cDNA library.....	36
2.3 Isolation of plasmid DNA.....	36
2.3.1 Plasmid mini preps	36
2.3.2 Plasmid midi preps	37
2.4 DNA Sample Sequencing	37
2.5 Embryonic tissue collection.....	38
2.5.1 Collection for wholemount in situ hybridisation	38
2.5.2 Amnion staining for embryonic sexing.....	40
2.5.3 Tissue collection for RNA extraction.....	40
2.6 Wholemount in situ hybridisation	40
2.6.1 Riboprobe preparation	40
2.6.2 Wholemount in situ hybridisation (WMISH).....	41
2.6.3 Photography and sectioning	43
2.7 In situ hybridisation to frozen sections	43
2.7.1 Single probe in situs.....	43
2.7.2 Section in situ hybridisation with two probes.....	45

2.7.3	Solutions	46
2.8	Genomic DNA extraction	46
2.8.1	Using Phenol:Chloroform.....	46
2.9	Southern blotting	47
2.10	Radioactive hybridisations.....	48
2.10.1	Radioactive probe preparation.....	48
2.10.2	Membrane hybridisation	48
2.11	Total RNA isolation.....	49
2.12	Polymerase Chain Reaction (PCR)	49
2.13	Reverse Transcription PCR (RT-PCR)	50
2.14	Analysis of P1-derived Artificial Chromosome (PAC) clones.....	51
2.14.1	Isolation of PAC DNA	51
2.14.2	Digestion of PAC DNA	52
2.15	Plasmid digests and DNA ligations	53
2.15.1	Plasmid DNA digestions	53
2.15.2	PCR product ligation	53
2.15.3	Isolation and purification of DNA fragments.....	54
2.15.4	Preparation of cloning vector	54
2.15.5	Ligation reactions	55
2.16	Transformation of E.coli with ligated plasmids.....	56
2.16.1	Heat-shock transformation:.....	56
2.16.2	Electroporation transformation:.....	56
2.17	LacZ reporter construct analysis.....	57
2.17.2	Genotyping transgenic mice	58
2.17.3	X-Gal staining of transgenic embryos.....	59
2.18	Organ Culture.....	59
2.19	Immunohistochemistry	61
2.19.1	Sample preparation.....	61
2.19.2	Laminin, mAb 407, and mAb 31.9 detection.....	61
2.19.3	p75 NTR Detection	62
2.19.4	Alkaline phosphatase staining	62
2.19.5	PECAM staining	62

Chapter 3: Expression analysis of candidate genes using wholemount *in situ* hybridisation64

3.1	Introduction	65
3.2	Objectives.....	67
3.3	DNA Microarrays.....	67
3.4	Results	68
3.4.1	Candidate clones.....	68
3.4.2	Alcohol Dehydrogenase Class IV, (Adh 4) expression is ...enhanced in the developing male gonad	70
3.4.3	Malic Enzyme-1 (Mod-1) shows male-enhanced expression in ... the developing gonad	70

3.4.4	Hairy/enhancer of split-related protein with YRPW motif 2 (<i>Hey2</i>) expression is enhanced in the male gonad at 13.5 dpc	71
3.4.5	Cerebellin 1 precursor protein (<i>Cbln1</i>) is expressed in the interstitium of male gonads at 13.5 dpc	74
3.4.6	Solute carrier family 20, member 1 (<i>Slc20a1</i>) is expressed in the developing testis from 12.5 dpc.....	74
3.4.7	GATA binding protein 2 (<i>Gata2</i>) expression is restricted to the ovary	74
3.4.8	Vanin-1 (<i>Vnn1</i>) is expressed in the developing male gonad	75
3.4.9	Negative candidate clones.....	77
3.5	Discussion.....	80
3.6	Summary.....	86

Chapter 4: Detailed characterisation of *Gata2* expression during gonadogenesis87

4.1	Introduction	88
4.2	Objectives.....	89
4.3	Strategy	90
4.4	Results	90
4.4.1	Expression studies of <i>Gata2</i>	90
4.4.1.1	Onset of expression	90
4.4.1.2	Expression from 12.0 dpc to 14.5 dpc	91
4.4.1.3	Expression at 15.5 dpc	91
4.4.2	Determination of cell type expressing <i>Gata2</i>	91
4.4.2.1	<i>Gata2</i> expression in W^e/W^e homozygous embryos	91
4.4.2.2	<i>Gata2</i> expression is limited to the germ cell lineage of the ovary ...	94
4.4.3	<i>Gata2</i> expression in XO embryonic gonads	96
4.5	Discussion.....	99
4.6	Summary.....	102

Chapter 5: Detailed characterisation of *Vanin-1* expression during gonadogenesis 103

5.1	Introduction	104
5.2	Aim of this chapter	107
5.3	Strategy	108
5.4	Results	108
5.4.1	Expression at 10.0-11.5 dpc	108
5.4.2	Onset of expression	109
5.4.3	Expression from 12.5 dpc.....	109
5.4.4	Expression of <i>Vanin-1</i> is not dependent on the presence of primordial germ cells.....	109
5.5	Isolation and analysis of a <i>Vanin-1</i> genomic fragment in transgenic mice	114
5.5.1	Isolation of a genomic fragment.....	114

5.5.2	Production of a LacZ reporter construct.....	117
5.5.3	Transgenic mice	118
5.6	Discussion.....	123
5.7	Summary.....	125
Chapter 6: Organ culture studies of Vanin-1 function		127
6.1	Introduction	128
6.2	Aim of this chapter.....	130
6.3	Strategy	131
6.4	Results	133
6.4.1	mAb 407 detects Vanin-1 in a similar pattern to WMISH	133
6.4.2	Expression of mAb 31.9, a non-specific monoclonal antibody	133
6.4.3	Visual assessment of cord formation in culture	135
6.4.4	Test cultures.....	135
6.4.5	Organ culture assays: scoring effects by visual inspection	136
6.4.6	Markers used in the analysis of cultured gonads	139
6.4.7	Marker analysis of cultured gonads.....	139
6.4.8	Effects of mAb 407 on the formation of the basement membrane.....	144
6.4.9	Effects of mAb 407 on migratory cell-types	148
6.4.9.1	p75NTR: a marker of peritubular myoid cells?	151
6.4.9.2	Expression of Patched-1 in gonad cultures	152
6.4.9.3	Expression of PECAM in cultured gonads.....	156
6.5	Discussion.....	157
6.6	Summary.....	161
Chapter 7: Analysis of gonadal development in embryos lacking Vanin-1		162
7.1	Introduction	163
7.2	Aim of this chapter.....	167
7.3	Strategy	169
7.4	Results	169
7.4.1	WMISH studies	169
7.4.2	Organ culture studies	178
7.4.2.1	Effects of culture on cord formation	178
7.4.2.2	Effect of mAb 407 on cord formation.....	179
7.4.3	Vanin-3 expression studies.....	181
7.4.4	Backcross of mutant allele to mouse strain C3H/HeH	181
7.5	Discussion.....	186
7.6	Summary.....	189

Chapter 8: General Discussion	190
8.1 Findings of this study	191
8.1.1 Gata2.....	191
8.1.2 Vanin-1	191
8.2 Further analysis of Gata2.....	192
8.2 Further analysis of Vanin-1	192
8.3 Success of this screen	196
8.3.1 Initial aims of this thesis: identification of new genes using a gene-based approach	196
8.3.2 Drawbacks of this method.....	196
8.4 Another gene-based mutagenesis approach for finding and analysing new genes	198
8.5 Phenotype-driven screens: an alternative approach to finding new genes	199
8.6 Future studies	200
References	201
Publications arising from this work	215

Figures and tables

Figure 1.1 Position and structure of the urogenital system within the mouse embryo at 10.5 dpc	7
Figure 1.2 Different gonadal cell lineages have bipotential fates that are determined by the sex of the organ in which they are located	7
Figure 1.3 Structure of the testis cords from 12.5 dpc.....	11
Figure 1.4 Pathways of testis and ovary development.....	29
Table 2.1 Embryonic staging using tail somite numbers	38
Table 2.2 Crosses used to generate embryos for study.....	39
Table 3.1 Candidate clones	69
Table 3.2 Riboprobe synthesis	69
Figure 3. 1 <i>Adh4</i> is expressed in the developing male gonad	72
Figure 3.2 <i>Mod-1</i> shows male-enhanced expression in the developing gonad	73
Figure 3.3 <i>Hey2</i> expression is male-specific in gonads at 13.5 dpc.....	76
Figure 3.4 <i>Cbln1</i> is expressed between the testis cords in male gonads at 13.5 dpc.....	76
Figure 3.5 <i>Pit1</i> is expressed in the developing testis from 12.5 dpc	78
Figure 3.6 <i>Gata2</i> transcription is restricted to the female gonad	79
Table 3.3 Negative candidate clones	77
Figure 3.7 <i>Vanin-1</i> is expressed in the testis of the developing male gonad ..	81
Figure 4.1 <i>Gata2</i> is first expressed at 11.5 dpc.....	92
Figure 4.2 <i>Gata 2</i> exhibits continued sexually dimorphic expression from 12.0 dpc to 14.5 dpc and is absent by 15.5 dpc.....	93
Figure 4.3 Ovaries from embryos homozyous for the <i>W^r</i> allele do not express <i>Gata2</i>	95
Figure 4.4 <i>Gata2</i> expression is restricted to germ cells of the ovary	98
Figure 4.5 <i>Gata2</i> expression in XO embryonic gonads	101
Figure 5.1 <i>Vanin-1</i> is not expressed between 11.0 and 11.5 dpc	110

Figure 5.2 Onset of <i>Vanin-1</i> expression is between 12.0 and 12.25 dpc.....	111
Figure 5.3 Expression of <i>Vanin-1</i> between 12.5 and 15.5 dpc.....	112
Figure 5.4 Expression of <i>Vanin-1</i> in gonads from W^e/W^e homozygotes.....	113
Figure 5.5 <i>Vanin-1</i> exon one probe detects a 6kb PAC genomic fragment...	115
Figure 5.6 6kb fragment cloned into pBluescript and sequenced.....	116
Figure 5.7 Orientation of <i>Vanin-1</i> first exon in the genomic fragment.....	119
Figure 5.8 Cloning of genomic fragment into p1229.....	120
Table 5.1 Transgenic founder mice.....	121
Figure 5.9 PCR genotyping potential transgenic mice and <i>LacZ</i> analysis of gonads.....	122
Table 5.2 <i>LacZ</i> expression in transgenic embryos at 13.5 dpc.....	123
Figure 6.1 Organ culture strategy.....	132
Figure 6.2 mAb 407 immunostaining results in a similar pattern to WMISH analysis using <i>Vanin-1</i> riboprobe.....	134
Figure 6.3 Binding of mAb 31.9 at 13.5 dpc.....	137
Figure 6.4 Initial cultures and cord formation: Score.....	138
Figure 6.5 Effect of culturing XY gonads in the presence or absence of mAb 407: experiments 1-6.....	140
Figure 6.6 Effect of culturing XY gonads in the presence or absence of mAb 407: experiments 7-9.....	141
Figure 6.7 Detection of mAb 407 in cultured gonads.....	142
Figure 6.8 Three cell markers of testis development.....	143
Figure 6.9 Expression of <i>Sox9</i> in cultured gonads.....	145
Figure 6.10 Expression of <i>Oct4</i> in cultured gonads.....	146
Figure 6.11 Expression of 3β HSD in cultured gonads.....	147
Figure 6.12 Laminin localisation in 13.5 dpc gonads.....	149
Figure 6.13 Laminin antibody staining of gonad cultures.....	150
Figure 6.14 Localisation of p75NTR in 12.5 and 13.5 dpc male gonads.....	153
Figure 6.15 p75NTR staining of gonad cultures.....	154
Figure 6.16 Expression of <i>Ptc-1</i> in cultured gonads.....	155

Figure 6.17 Expression of PECAM-1	158
Figure 7.1 Generation of <i>Vanin-1</i> -deficient mice	165
Figure 7.2 No <i>Vanin-1</i> expression is observed in <i>Vanin-1</i> ^{-/-} gonads at 13.5 dpc	168
Figure 7.3 Interstitial marker analysis in <i>Vanin-1</i> ^{-/-} and +/+ embryonic male gonads	171
Figure 7.4 Expression of interstitial cell markers at 13.0 dpc	172
Figure 7.5 longitudinal sections of gonads stained for interstitial cell markers	173
Figure 7.6 p75 ^{NTR} expression in sections of <i>Vanin-1</i> ^{-/-} and BALB/c male gonads	174
Figure 7.7 Expression of <i>Dhh</i> in male gonads at 13.5 dpc	175
Figure 7.8 Expression of <i>Oct4</i> and <i>Sox9</i> in male and female gonads at 13.5 dpc	176
Figure 7.9 Longitudinal sections of gonads analysed for expression of <i>Oct4</i> and <i>Sox9</i> by WMISH	177
Figure 7.10 layout of gonads placed in culture	178
Figure 7.11 Effects of culture on cord formation of <i>Vanin-1</i> ^{-/-} and BALB/c gonads	182
Figure 7.12 Effects of mAb 407 on cord formation in <i>Vanin-1</i> ^{-/-} embryonic gonads <i>in vitro</i>	183
Figure 7.13 Expression of <i>Ptc-1</i> in cultured male gonads	184
Figure 7.14 <i>Vanin-3</i> expression studies	185

Abbreviations

AMH	Anti-Müllerian Hormone
CE	Coelomic epithelium
GR	Genital ridge
bp	Base-pair
dpc	Days <i>post coitum</i>
HIS	Heat inactivated seep serum
NMUR	Normalised mouse urogenital ridge
PAC	P1-derived artificial chromosome
PCR	Polymerase chain reaction
PECAM	Purified rat anti mouse CD31
PGC	Primordial germ cell
PMC	Peritubular myoid cell
RT-PCR	Reverse-transcription polymerase chain reaction
SAP	Shrimp alkaline phosphatase
ts	Tail somites
UB	Ureteric bud
UGR	Urogenital riges
WD	Wolffian duct
WMISH	Wholemout <i>in situ</i> hybridisation

Acknowledgments

I would like to thank everyone in the Sexual Development Group past and present especially Kate, Sean, James and Rae. Thanks to Lee, Sam and John for helpful reading of this manuscript. Also thanks to Ruth Arkell, Debora Bogani, Elaine Whitehill, and to Steve, Kevin and Adrian in Imaging Services, and all other core facilities.

A special thanks to my boss Andy Greenfield for his guidance and encouragement, and to my other bosses, Lucy and Niamh. I am also grateful to all my family for their support.

Chapter 1: Introduction

1.1 Mammalian sex determination and sexual development

The anatomical basis of sexual development in mammalian embryos is the bipotential gonad, which in the mouse arises as a thickening of the mesonephros at about 10.5 days *post coitum* (dpc). The developmental fate of this indifferent gonad depends on the genetic sex of the individual. Genetic sex is established at fertilisation with the inheritance of either an X or a Y chromosome from the father. Depending on whether a Y chromosome is present this bipotential gonad will either become a testis or an ovary. If a Y chromosome is present a testis develops through the action of the sex determining gene *Sry* (Gubbay et al., 1990). The process by which *Sry* commits the bipotential gonad to the testicular fate is known as sex determination. Once the testes begin to differentiate they secrete factors, for example anti-Müllerian hormone (AMH, otherwise known as Müllerian-inhibiting substance, or MIS) and testosterone, which promote masculinisation of the rest of the embryo. There are many steps in this process that, if adversely affected by mutation (Vilain, 2002) or environmental insult (Sharpe, 2001), will give rise to different degrees of sex reversal, gonadal dysgenesis and infertility.

Human sex reversal occurs at an estimated frequency of 1 in every 20 000 births and results in XY females, XX males, or XX or XY true hermaphrodites (McElreavey et al., 1993). According to current knowledge only 10-15% of XY females result from *SRY* open reading frame mutations, 10-15% from

SRY deletions while the remaining 70-80% are unaccounted for by mutations in any of the known sex determining genes. In addition, only 80-90% of XX males are *SRY* positive while the remaining 10-20% are unexplained (Scherer et al., 1998). Only a small percentage of XX hermaphrodites have been shown to be *SRY* positive, the great majority are still unexplained. A small number of genes have been isolated as a consequence of their ability to cause sex reversal in the human population when mutated, for example, *SOX9* (Wagner et al., 1994) and *DAX1* (Guo et al., 1995), *WT1* (Pelletier et al., 1991) and *SF1* (Ingraham et al., 1994). Clearly, there must be many more genes with important roles in sex determination and development than have so far been identified. The search for these genes has generated much interest in the processes of sex determination and sexual differentiation.

Mammalian sexual development is a unique example of organogenesis because the gonad arises as a bipotential primordium in the male and female embryo and undergoes development into one of two distinct organs due to the action of *SRY*. This binary system of development provides the opportunity to study how genes control cell fate in organogenesis. Also, an important feature of this developmental process is that the gonad is not essential for viability. Hence, adult carriers of mutations in key genes involved in sexual development often survive and are easily identified due to their infertility or because they exhibit gonadal dysgenesis or sex-reversal. It is also possible to study mutations that lead to a complete absence of the

gonad, without loss of the embryo. Hence, the genetics and biology of gonad development permits the use of powerful functional techniques such as the generation of null mutations by gene targeting. This makes mammalian sexual development a useful system to study organogenesis and cell fate determination during development.

In this introduction the processes of mammalian sex determination and differentiation of both the testis and the ovary will be described, along with our current knowledge of the molecular genetic mechanisms underlying these processes. Gaps in our knowledge will also be described and an overview of the various screens for new genes which may help to fill these gaps. Two genes described in this thesis, *Vanin-1* and *Gata2*, have been identified as part of an expression-based screen and their expression profiles suggest they may play a part in the development of the gonads.

1.2 Sexual development in the mouse

The mouse has been used as the primary model in the study of mammalian sexual development because of the similarity of mouse development and the mouse genome to that of the human, together with the growing power of mouse genetics and genomics.

1.2.1 Origin and development of the gonads

The genital ridge, comprising the indifferent gonad together with the mesonephros, develops in the mouse from intermediate mesoderm from around 9.5 dpc. The pronephros, which is vestigial in mammals, forms at the anterior end of the body cavity. The mesonephros develops centrally and gives rise to the gonads and adrenal gland. The metanephros develops more posteriorly and develops into the kidney. The gonad begins to develop along the ventromedial side of the mesonephros at about 10.0 dpc and consists of somatic cells and primordial germ cells (PGCs) (Figure 1.1). The somatic cells originate from the mesonephros and the coelomic epithelium. This is a single layer of epithelial cells which line the coelomic cavity (Karl and Capel, 1998). PGCs first form in both sexes at the base of the allantois at 7.5 dpc, and then migrate through the gut mesentery and reach the genital ridge at 9.5 dpc. These then enter the gonads at 10.0 dpc as they are forming (Ginsburg et al., 1990). Until 11.5 dpc the gonads from both sexes are morphologically identical and are able to form either testes or ovaries. They consist of four different cell lineages, each lineage having a bipotential cell fate which is determined by the sex of the organ in which they are located (Figure 1.2).

1. **The supporting cells.** These cells differentiate into Sertoli cells in the testis and follicle cells in the ovary. The primary role of both these cell types is to nurture germ cells during their development. Sertoli cells arise from the coelomic epithelium (Karl and Capel, 1998) and play a

1.2.1 Origin and development of the gonads

The genital ridge, comprising the indifferent gonad together with the mesonephros, develops in the mouse from intermediate mesoderm from around 9.5 dpc. The pronephros, which is vestigial in mammals, forms at the anterior end of the body cavity. The mesonephros develops centrally and gives rise to the gonads and adrenal gland. The metanephros develops more posteriorly and develops into the kidney. The gonad begins to develop along the ventromedial side of the mesonephros at about 10.0 dpc and consists of somatic cells and primordial germ cells (PGCs) (Figure 1.1). The somatic cells originate from the mesonephros and the coelomic epithelium. This is a single layer of epithelial cells which line the coelomic cavity (Karl and Capel, 1998). PGCs first form in both sexes at the base of the allantois at 7.5 dpc, and then migrate through the gut mesentery and reach the genital ridge at 9.5 dpc. These then enter the gonads at 10.0 dpc as they are forming (Ginsburg et al., 1990). Until 11.5 dpc the gonads from both sexes are morphologically identical and are able to form either testes or ovaries. They consist of four different cell lineages, each lineage having a bipotential cell fate which is determined by the sex of the organ in which they are located (Figure 1.2).

1. **The supporting cells.** These cells differentiate into Sertoli cells in the testis and follicle cells in the ovary. The primary role of both these cell types is to nurture germ cells during their development. Sertoli cells arise from the coelomic epithelium (Karl and Capel, 1998) and play a

central role in testis development, since it is the pre-Sertoli cells that express *Sry* (Koopman et al., 1990).

2. **The steroidogenic cells.** These cells are responsible for the production of sex hormones that determine the secondary sexual characteristics of the embryo. In male gonads, these cells differentiate into Leydig cells and secrete testosterone and probably originate from the anterior mesonephros and/or the adrenal primordium before 11.5 dpc. In female gonads, the cells develop as theca cells and produce oestrogen.
3. **The primordial germ cells (PGCs).** The developmental fate of PGCs depends on the environment in which they develop and they play no role in determining the sex of the gonad (McLaren, 1995). In males, PGCs enter mitotic arrest at 12.5 dpc whereas germ cells in an ovary enter arrest in meiosis a day later (McLaren and Southee, 1997).
4. **Other cells** can be found in the gonad. These are also somatic and consist of peritubular myoid cells (PMCs), endothelial cells and perivascular mesenchyme cells. PMCs are only found in the testis, no homologous lineage exists in the ovary. They are thought to originate in the mesonephros, migrate into the gonad and probably co operate with Sertoli cells in the formation of testis cords (Tung et al., 1984). Endothelial cells are found in the gonads of both sexes and form its

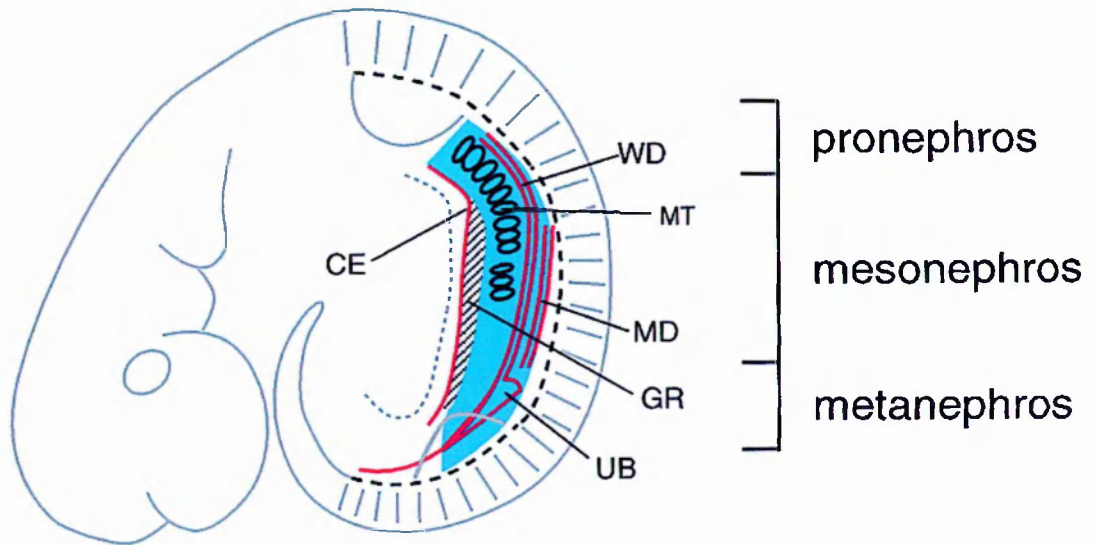

Figure 1.1

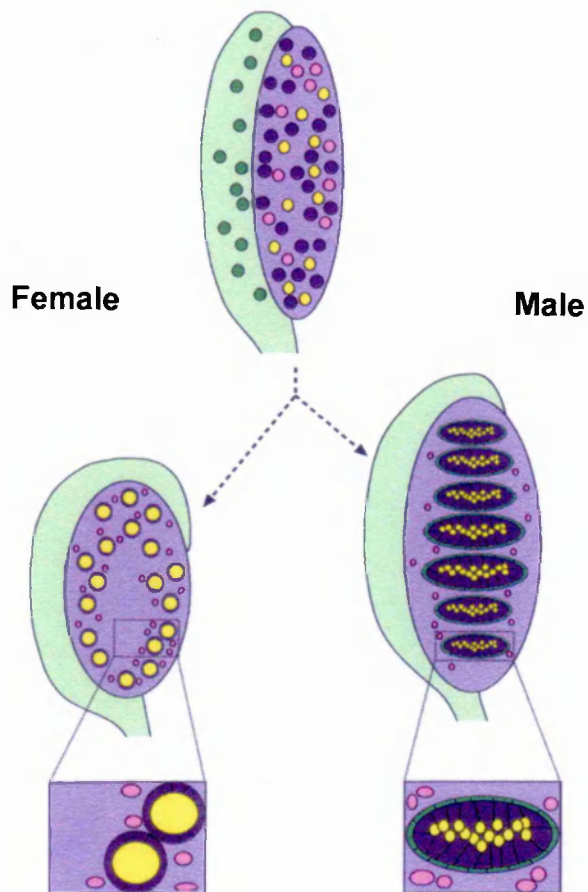

Figure 1.2

Figure 1.1 Position and structure of the urogenital system within the mouse embryo at 10.5 dpc

Epithelial structures are shown in red, mesenchymal structures are shown in blue, and the striped region denotes the genital ridge (GR). (WD) Wolffian duct; (MT) mesonephric tubules; (MD) Müllerian duct; (UB) ureteric bud; (CE) coelomic epithelium. From Swain and Lovell-Badge (1999).

Figure 1.2 Different gonadal cell lineages have bipotential fates that are determined by the sex of the organ in which they are located

Indifferent gonads form in both sexes at mid-gestation (top), and can develop as either testes or ovaries depending on the genetic sex (bottom). Each of the cell types in the gonad must differentiate accordingly. Germ cells (yellow) give rise to oocytes in the female or mitotic spermatogonia in the male. Supporting cells (dark pink), become either Sertoli cells of the testis or granulosa cells in the ovary. Steroidogenic cells (pink) become Leydig cells in the male or theca cells in the female. In the male, *Sry* induces migration of cells from the mesonephros (green) which include precursors of the peritubular myoid cells and other interstitial cell types. From Loffler and Koopman (2002).

vasculature. By 12.5 dpc this is most noticeable in the male with the formation of the large coelomic vessel.

1.2.2 Sex determination

The sex determination process is set in motion with the expression of the male-determining gene *Sry* in the developing male gonad. The expression of this putative transcription factor occurs in a narrow time window between 10.5 and 12.0 dpc (Hacker et al., 1995b; Jeske et al., 1995). The expression of *Sry* has a profound effect on the male gonad resulting in an increase in size compared to the female gonad and to the formation of testis cords. These cords can be seen at 12.5 dpc under a light microscope and represent the first morphologically visible difference between male and female gonads. Testis cords are formed by three cell types: primordial germ cells aggregate and are surrounded by Sertoli cells, which are surrounded, in turn, by peritubular myoid cells. Sertoli cells act co-operatively with PMCs to lay down a basement membrane that defines the testis cord (Tung et al., 1984) (Figure 1.3 A and B). Little is known about the cellular and molecular processes involved in testis cord formation. Migration of cells from the mesonephros is required, however, germ cells are not required as testis cords form in mutant mice lacking PGCs (Buehr et al., 1993b). In the absence of *Sry* expression an ovary develops. This process will be described in section 1.4.

1.2.3 Sexually dimorphic development of the mesonephros

Like the gonad, the mesonephros has a bipotential fate, developing into one of the sex-specific reproductive tracts depending on the gonadal sex of the embryo. In male embryos, the Wolffian duct develops into the vas deferens, epididymis and seminal vesicle. In females, the Müllerian duct forms the oviducts, uterus and upper vagina. The fate of the mesonephros is dictated by the sex of the neighbouring gonad, and is characterized by the sex-specific regression of either the Wolffian or Müllerian duct. The testis secretes anti-Müllerian hormone (AMH) and testosterone. Together, these hormones cause Müllerian duct regression and the persistence of the Wolffian duct. In the absence of these hormones (i.e. in a female embryo), the Wolffian duct regresses and the Müllerian duct persists (Behringer et al., 1994).

1.2.4 The importance of the supporting cell lineage in male sexual development

Sertoli cell precursors are thought to act as the organizing centre for the developing testis by directing all other cell types into their respective lineages. The Sertoli cell is the only cell type which has a strong bias for a Y chromosome in XX \leftrightarrow XY mosaic mice (Palmer and Burgoyne, 1991). Therefore, *Sry*-expressing pre-Sertoli cells are thought to start the

differentiation process in other cell types *via* cell-cell contacts or the production of signalling molecules. In the embryonic gonads of XX \leftrightarrow XY chimaeras as few as 25% of the pre-Sertoli cells require a XY chromosomal constitution in order for normal testis development to ensue. This suggests that Sertoli cells, once specified by *Sry*, are able to recruit other cells to the male pathway, irrespective of their chromosomal content and that no genuinely cell-autonomous step exists in mammalian sex determination. Sertoli cells also play a key role in testis cord formation by interacting with PMCs. They also signal to other cell types in the gonad and mesonephros. For example, Sertoli cell signals are necessary to stimulate the production of testosterone by Leydig cells (Koopman et al., 2001). This hormone (along with AMH) leads to the masculinisation of the mesonephros as described in section 1.2.3. Sertoli cells are also thought to induce mitotic arrest in PGCs (McLaren, 1995). When germ cells differentiate in ectopic tissues, such as the adrenal, they enter into meiotic arrest (McLaren, 1995), suggesting that these cells are programmed to arrest in meiosis and that the role of the embryonic testis is to produce a factor which will prevent this and cause them to enter mitotic arrest, and hence produce sperm in the adult. Hence, Sertoli cells have a central role in sex determination and testis development.

One of the important early products of Sertoli cells is anti-Müllerian hormone. This hormone is expressed from 12.0 dpc and is secreted from Sertoli cells. Its role is to initiate regression of the Müllerian duct by

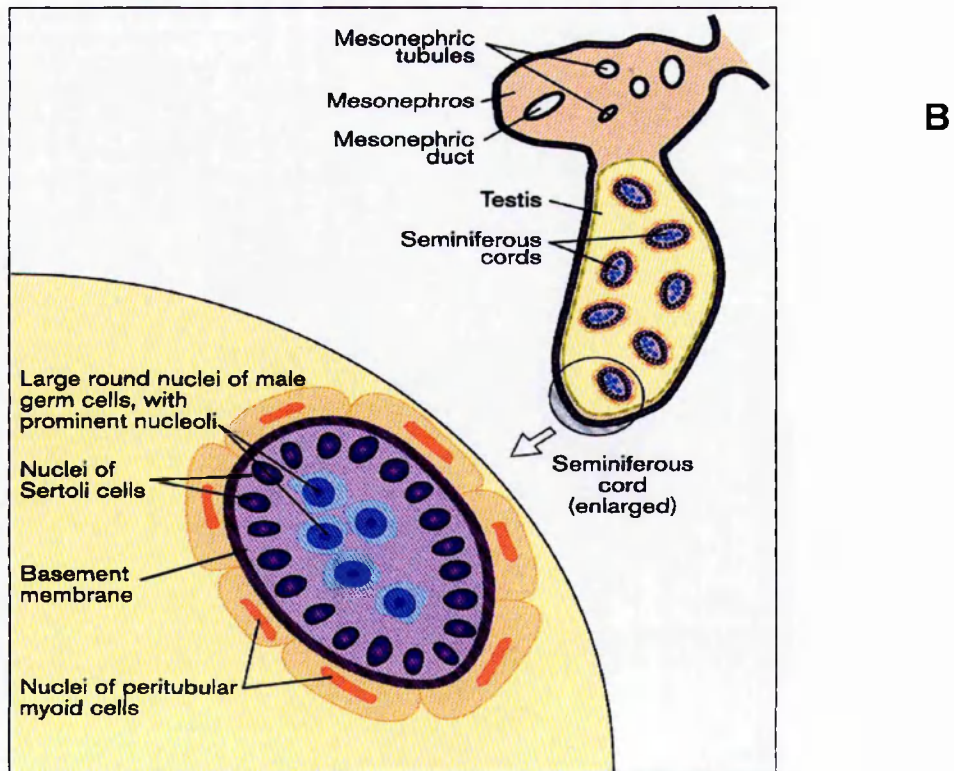
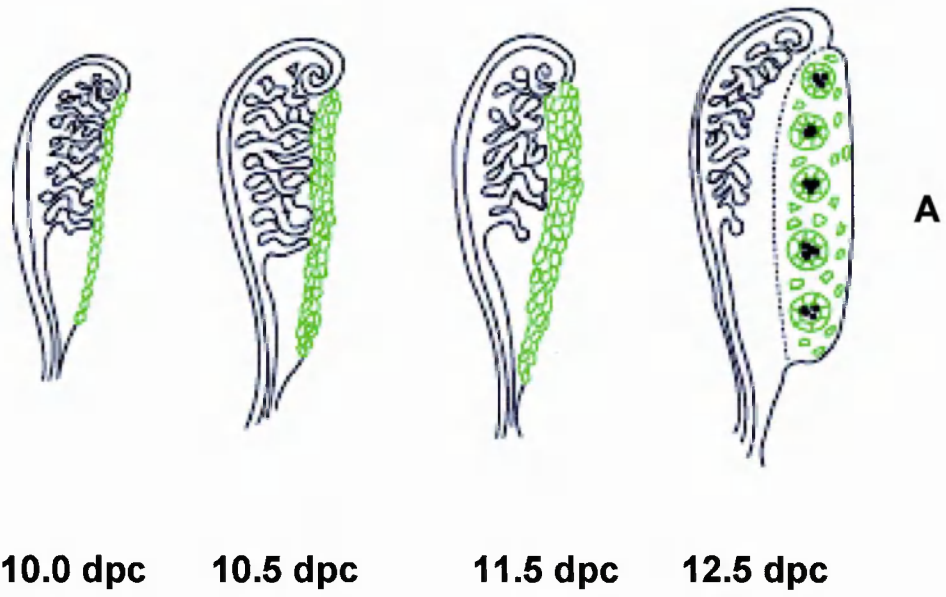

Figure 1.3

Figure 1.3 Structure of the testis cords from 12.5 dpc

(A) Testis cords begin to form in the male gonad Between 11.5 and 12.5 dpc. From (Capel, 2000).

(B) Cords consist of mitotic germ cells with large round nuclei. These are surrounded by Sertoli (supporting) cells. Peritubular myoid cells migrate into the gonad from the mesonephros. They interact with Sertoli cells in order to form a basement membrane between them, thus forming the testis cord.

binding to its receptor (AmhIIR), which is present on the cell membrane of Müllerian duct mesenchymal cells (Münsterberg and Lovell-Badge, 1991). Hence, the expression of Amh links gonad development to mesonephric development. Various genes expressed in Sertoli cells have been implicated in the regulation of *Amh*, for example, *Sf1*, *Sox9*, and *Wt1*.

AmhIIR is also expressed in Sertoli cells (di Clemente et al., 1994), and Leydig cells (Racine et al., 1998) of the developing testis.

1.2.5 The importance of mesonephric cell migration in male sexual development

Many studies have demonstrated that cell migration from the mesonephros and the coelomic epithelium is required for the development of the gonads. Early organ culture studies showed that XY gonads would not form testis cords without an adjoining mesonephros. Neither will they form if a membrane is placed between the two and cells cannot migrate (Buehr et al., 1993a; Merchant-Larios et al., 1993). It has also been shown that this migration is male-specific and directly depends on the expression of *Sry* (Capel et al., 1999; Martineau et al., 1997). At least three cell lineages have been demonstrated to migrate into the gonad from the mesonephros: PMCs, endothelial cells and perivascular cells. PMCs co-operate with Sertoli cells *in vitro* to form a basement membrane (Tung et al., 1984). Therefore, it is thought that migration of PMC precursors from the mesonephros is required

for interaction with Sertoli cells and formation of the testis cords (Tilman and Capel, 1999b).

Mesonephric cell migration into the XX gonad does not occur during ovary development after 11.5 dpc (Martineau et al., 1997). However, mesonephric cell migration into XX gonads can be induced when the gonad is cultured between an XY gonad and a mesonephros of either sex or when a protein extract from XY gonads is cultured next to an XX gonad. This migration leads to the formation of testis cords in the XX gonad, indicating that precursor cells capable of differentiating into Sertoli cells are present in the female gonad at 11.5 dpc (Tilman and Capel, 1999b). These experiments also demonstrate that the signal for cell migration is a chemoattractant protein signal capable of acting over a distance of 100 μ m (Martineau et al., 1997). Cell migration and testis cord formation is also seen in XX gonads carrying an *Sry* transgene (Capel et al., 1999). This demonstrates that the chemoattractant signal is a direct consequence of *Sry* expression and that *Sry* expression is necessary and sufficient to induce mesonephric cell migration and testis formation.

1.3 Molecular genetics of male gonad development

1.3.1 Early acting genes

Many of the genes involved in sexual development have been identified by analysis of mutations in humans and mice (spontaneous or engineered) that

lead to sex reversal or abnormal development of the reproductive organs. Such mutation studies in the mouse have identified several genes essential for early gonad development, including *Sf1*, *Wt1*, *Lim1*, *Lhx9* and *Emx2*. All these genes are expressed early in both sexes.

Sf1 encodes a nuclear hormone receptor and is expressed as soon as the gonads form at 10.0 dpc (Ikeda et al., 1994). In males this expression can be seen in Leydig and Sertoli cell precursors up to 12.5 dpc. This expression continues in Leydig cells and Sertoli cells. In females expression is observed in somatic cells until 13.0 dpc (Ikeda et al., 1996). In *Sf1* $-/-$ mice the gonad begins to form, however, by 12.5 dpc in both sexes apoptosis causes it to regress (Luo et al., 1994).

WT1 is the gene mutated in Wilm's tumour, an embryonic kidney tumour affecting 1 in 10000 children. As well as this role in tumour suppression *WT1* also plays a role in development. In mice homozygous for a null allele of *Wt1* neither the gonads or kidneys form (Kreidberg et al., 1993). Point mutations in *WT1* are associated with two syndromes, Denys-Drash and Fraiser, both of which are characterized by urogenital abnormalities ranging from gonadal dysgenesis to sex reversal (Barboux et al., 1997; Pelletier et al., 1991). *WT1* is characterized by complex post transcriptional modifications with up to 24 different isoforms. Two of these lead to the omission or addition of three amino acids (KTS) which differ in their ability to activate or repress transcription (Menke et al., 1998). Transgenic studies have

demonstrated that these two isoforms possess distinct functions *in vivo*. Mice lacking only the KTS-negative isoform (-KTS-/-) exhibit an increase in apoptosis at 11.5 dpc consistent with the phenotype of mice lacking both isoforms. However, mice lacking just the +KTS isoform (+KTS-/-) show no increase in apoptosis and XX mice develop normally, but XY mice show male to female sex reversal (Guo et al., 2002; Hammes et al., 2001). *Sry* expression is decreased in +KTS -/- mice (Guo et al., 2002) indicating that *Wt1* may be a regulator of *Sry* expression.

Mice carrying null mutations for *Lim1*, *Lhx9*, and *Emx2* also do not form gonads, though the precise roles of these genes in gonad development remains unclear.

1.3.2 Sry and Sox9

Up to approximately 12.0 dpc the gonads in both sexes are morphologically indistinguishable. The pathway leading to sexual dimorphism is initiated at 10.5 dpc when *Sry* begins to be expressed in the male gonad. Initially it was thought to be expressed in a wave starting at the anterior end of the gonad, with each cell only exhibiting expression for a few hours (Hacker et al., 1995b; Swain et al., 1998). More recently this expression is thought to originate from the centre of the gonad and emanate towards the poles (Bullejos and Koopman, 2001). As mentioned previously, using XX<->XY mosaic mice it has been shown that the vast majority of Sertoli cells are XY

whereas other cells exhibit no bias. Thus, *Sry* is thought to act on supporting cells to promote Sertoli cell differentiation. Sertoli cells then go on to trigger further testis differentiation in other cell types. How *Sry* mediates these changes is unclear, as is whether it acts on only one or more downstream targets.

Sry was identified from the minimal region of the Y chromosome required to induce male development in mice (Gubbay et al., 1990). XX mice carrying this region as a transgene develop as infertile males (Koopman et al., 1991) and XY individuals with deletions of the region containing *Sry* develop as females (Gubbay et al., 1992). These findings demonstrate that *Sry* is necessary and sufficient for male sexual development.

The exact function of the *Sry* protein is unclear. *Sry* is a putative transcription factor with an HMG-box (High Mobility Group) DNA binding domain that is thought to induce a bend in DNA by binding in the minor groove (Giese et al., 1992). This DNA bending is critical to the sex determining function of *Sry*, as demonstrated by sex reversal mutations that alter the degree of DNA bending (Pontiggia et al., 1994). Like other HMG-box containing proteins, *Sry* is thought to act as an architectural transcription factor, bringing about changes in gene expression by inducing local changes in chromatin configuration (Giese et al., 1994). It is not clear whether it acts to repress or activate transcription.

One possible direct target of *Sry* is *Sox9*. *Sox9* is a member of the SOX gene family, which encodes a HMG-box DNA-binding domain similar to that of *Sry*. *Sox9* is expressed in the gonads of both sexes at 10.5 dpc at low levels, but at 11.5 dpc it becomes down-regulated in females. Furthermore, as *Sox9* acquires this sexually dimorphic pattern of expression its protein localization changes from cytoplasmic to nuclear in pre-Sertoli cells (da Silva et al., 1996). It is also expressed in the developing chondrocytes, heart, pancreas and central nervous system. Humans with *SOX9* mutations exhibit degrees of XY sex reversal along with the dwarfism syndrome Campomelic dysplasia. Transgenic studies have shown that *Sox9* is sufficient to induce testis formation (Vidal et al., 2001), and it has been proposed that *Sry* directly regulates *Sox9* (Canning and Lovell-Badge, 2002).

Study of the Odd Sex (*Ods*) mouse (ocular degeneration with sex reversal) initially suggested that in XX gonads there may exist a negative regulator of *Sox9* (Bishop et al., 2000). *Ods* is a transgenic line carrying a tyrosinase minigene driven by a dopachrome tautomerase (*Dct*) promoter integrated upstream of the *Sox9* promoter, also associated with a deletion of 134kb in this region. *Ods* results in ectopic expression of *Sox9* in the gonad causing female to male sex reversal in XX *Ods*/+ mice, along with eye defects. It was thought that the 134kb deletion removed a site required for a negative regulator of *Sox 9* expression and hence *Sox9* could maintain a male-specific pattern of development in these mutant gonads. However, this deletion

alone is not responsible for the observed sex reversal (Qin et al., 2004). Therefore, it has been proposed that the *Ods* sex reversal is caused by the *Dct* promoter activating an enhancer element that is sufficient to activate *Sox9* expression in XX gonads and induce female to male sex reversal.

Sox8, a homologue of *Sox9*, can also activate the *Amh* promoter. Studies of mice doubly homozygous for null mutations in both *Sox8* and *Sox9* also suggests it can re-enforce the action of *Sox9* (Schepers et al., 2003).

1.3.3 Other key genes

Once Sertoli cell fate is triggered by *Sry*, genes involved in Sertoli cell function become activated. One of these genes is *Amh*. *Amh* was first characterized as the factor in serum that induces masculinisation of the female twin in freemartin cattle (Jost et al., 1973). It is a member of the transforming growth factor beta (TGF β) family and is expressed in the Sertoli cells from 11.5 dpc onwards (Münsterberg and Lovell-Badge, 1991). It is responsible for the regression of the Müllerian duct, which develops into the female reproductive tract. Mis-expression of AMH in XX gonads leads to the regression of this duct, while in AMH $-/-$ males both Müllerian and Wolffian ducts develop (Behringer et al., 1994). However, testis development and spermatogenesis occurs normally in these animals, with infertility being caused by the presence of the female duct.

Studies have demonstrated that Sox9 and Sf1 can interact and bind to the *Amh* promoter *in vitro* (De Santa Barbara et al., 1998) and *in vivo* (Arango et al., 1999), though other targets of Sox9 probably exist.

Another gene expressed in a sexually dimorphic manner, specifically in Sertoli cells at 12.5 dpc, is Desert Hedgehog (*Dhh*). In *Dhh* ^{-/-} mice, females develop normally whereas males are infertile owing to the complete absence of mature sperm (Bitgood et al., 1996). Patched-1 (*Ptc-1*), a likely target of *Dhh* shows down regulation in *Dhh* ^{-/-} mice. It is expressed in Leydig cells and PMCs (Clark et al., 2000). Both these cell types are located in the interstitium, with PMCs surrounding the cords, separated from the Sertoli cells by a basement membrane. Mature Leydig cells are absent in these null mice, therefore *Ptc1* is required for the formation of mature Leydig cells. DHH/PTC1 signalling is thought to trigger Leydig cell differentiation by upregulating *Sf1* and *Scc* (P450 side chain cleavage enzyme, an early marker of Leydig cells) expression in *Ptc1*-expressing precursors located outside the testis (Yao et al., 2002). Moreover, PMCs in the adult do exhibit defects that could account for their sterility. During embryogenesis, defects in *Dhh* ^{-/-} mice begin to occur at 13.5 dpc when the basement membrane, that de-limits the testis cord, is disrupted. Also, some germ cells are observed outside the cords (Pierucci-Alves et al., 2001). Sterility of these mice could therefore be caused by a lack of PMC maturation due to absence of *Dhh* signaling.

A critical feature of XY gonad development is the migration of cells from the mesonephros into the gonad. One gene which plays a role in this process is Fibroblast growth factor 9 (*Fgf9*) (Colvin et al., 2001). During development *Fgf9* ^{-/-} gonads show disrupted cord formation and Sertoli cell differentiation and aberrant testicular differentiation. A role in migration of cells from the mesonephros was suggested by the addition of *Fgf9* to gonads in organ culture. Addition of this protein was able to induce mesonephric migration into XX gonads. *Fgf9* could also act to stimulate mesenchymal (interstitial) proliferation. This was demonstrated by BrdU labelling whereby a severe reduction in labeled cells was observed in *Fgf9* ^{-/-} XY gonads. During development *Fgf9* ^{-/-} gonads show disrupted cord formation and Sertoli cell differentiation and aberrant testicular differentiation. *Fgf9* ^{-/-} mouse phenotypes range from testicular hypoplasia to complete male-female sex reversal. *Fgf9* could function to stimulate cell proliferation in order to facilitate the production of pre-Sertoli cells. Therefore any reduction in this process would result in a loss of Sertoli and interstitial cells. *Fgf9* signaling is thought to be mediated through Fibroblast growth factor receptor 2 (*Fgfr2*) (Schmahl et al., 2004). *Fgfr2* is located on the cell membrane in proliferating coelomic epithelial cells which give rise to Sertoli cells. Furthermore, it is also found in the nucleus of cells that show nuclear localisation of Sry and Sox9. This could imply differing roles for Fgf signaling between proliferating cells and cells differentiating under the influence of Sry. Nuclear localization

of Sox9 and Fgfr2 are lost in mice lacking *Fgf9*, though it is unknown whether Sox9 expression is upstream or downstream of *Fgfr2*.

The family of Platelet-derived growth factor receptors and ligands has an established role in migration, proliferation and differentiation of cells in various organ culture systems. Recently it has been demonstrated that *Pdgfr- α* plays an important role in promoting testis cord organization and fetal Leydig cell development (Brennan et al., 2003). XY *Pdgfr- α* *-/-* gonads display disruptions in the organization of the vasculature and in the partitioning of interstitial and testis cord compartments. Defects in cell proliferation and migration also occur in these mice. *Pdgfr- β* *-/-* mice exhibited no overt defects in gonads between 11.5 and 13.5 dpc. Therefore a role for this receptor in gonad development was ruled out. The gene encoding its ligand, *Pdgf-B*, was also shown to be expressed at low levels in endothelial cells in the developing gonads of both sexes. However, it has also been reported that the B-ligand is expressed at higher levels in the male (Puglianiello et al., 2004). Furthermore, addition of this ligand to a serum-free culture system will allow male gonads to form testis cords. This indicates that the β receptor and ligand do play a role in testis cord development.

One gene which is expressed later in development in a sexually dimorphic manner is *Dmrt1*. This gene was identified *via* homology to the genes doublesex (*dsx*) in *Drosophila* and *mab-3* in *C. elegans*, all of which contain a

DM-DNA binding motif. *Dsx* and *mab-3* play a role in sex determination and male-specific differentiation in flies and worms. *Dmrt1* is expressed in the gonads of both sexes early in development and then becomes specific to the testis between 13.5 dpc and 14.5 dpc (Raymond et al., 1999). Studies of mice lacking *Dmrt1* reveal a role for this gene later in testis development with *Dmrt1* required for postnatal testis development (Raymond et al., 2000).

1.4 Ovarian development

In comparison to testis development the molecular and cellular details of ovary development remain elusive for a variety of reasons. These include the failure to identify a large number of genes which play a role in its development, the lack of cell markers with which to study the differentiation of ovarian cell lineages and the absence of any clear morphological compartmentalization before birth. In contrast, it is the characteristic architecture of the testis that allows examples of disruption of male gonad development and their cellular basis to be identified with relative ease.

Up to 11.5 dpc the gonad is morphologically indistinguishable between the sexes. The four gonadal cell lineages present each have a bipotential fate, as described in section 1.2.1. Cellular changes do occur in the ovary at the same time as testis cords are forming in the male. Loose cord-like structures begin to form at 12.0 dpc, known as ovigerous cords (Konishi et al., 1986; Odor and Blandau, 1969), although they are not observable under the light microscope.

Isolation of *Caveolin-1* and studies of its expression have also revealed a complex vascular network in the developing ovary (Bullejos et al., 2002). PGCs cluster at the centre of these ovigerous cords surrounded by somatic cells. Unlike the male, the presence of germ cells is essential for the proper development of the ovary. Mutants which contain no germ cells, for example W^r/W^r homozygotes, exhibit ovarian dysgenesis (Buehr et al., 1993b). Meiotic germ cells exert important regulatory functions over the surrounding somatic cells and when ovaries become depleted of germ cells cord-like structures form (Behringer et al., 1990). The presence of meiotic germ cells also inhibits mesonephric cell migration into gonads *in vitro* (Yao et al., 2003).

1.4.1 Molecular genetics of ovarian development

Early experiments (Jost, 1947) showed that removal of gonads from fetal rabbits led to the development of female secondary sex characteristics, whether the animal was XX or XY. Male secondary sex characteristics depend on the presence of a testis and this led to the hypothesis that female development is the “default” state because no gonads are required to specify female characteristics.

To date, two genes have been reported to play a role in ovarian development, *Dax1* and *Wnt4*. Both are expressed in the XX gonad from 11.5 dpc.

DAX1 is an X-linked gene that was identified from a region on human chromosome Xp21 linked with Dosage Sensitive Sex reversal (DSS) (Bardoni et al., 1994). Duplication of the genomic region containing *DAX1* causes the development of XY females, which suggests that a dosage-sensitive step exists in mammalian sexual development (Bardoni et al., 1994).

Dax1 is expressed in the gonads of both sexes until 11.5 dpc when its expression becomes down-regulated in males and up-regulated in female gonads (da Silva et al., 1996). This expression pattern is reciprocal to that of *Sry* and *Sox9*. *Dax1* is expressed in the somatic compartment of male gonads at 11.5 dpc, and so is in a position to antagonise *Sry* action, thereby potentially explaining the DSS phenomenon.

Such an antagonistic effect of *Dax1* on *Sry* is seen in transgenic mice expressing *Sry* and *Dax1* under the control of the *Dax1* promoter region. Female development ensues in transgenes with higher expression of a *Dax1:Dax1* transgene than of a *Dax1:Sry* transgene. Conversely, XY males develop when the expression of the *Dax1:Sry* transgene is higher than the *Dax1:Dax1* transgene. This suggests a direct antagonistic interaction of the two transcription factors in these animals (Carulli et al., 1998). Importantly, whether such gain-of-function studies reflect the normal role of *Dax1* during gonadogenesis is unclear. Ironically, mice lacking *Dax1* exhibit defective spermatogenesis and Leydig cell hypoplasia, whilst female development is unaffected (Ito et al., 1998).

Wnt4 exhibits a similar expression pattern to *Dax1* with transcripts present in both sexes until 11.5 dpc followed by down-regulation in XY gonads. *Wnt4* ^{-/-} XX mice fail to form the Müllerian duct whereas the Wolffian duct differentiates as normal. These mice also exhibit ectopic Leydig cell development. XY null mice were reported to have no testis defects (Vainio et al., 1999). *Wnt4* has been demonstrated to repress mesonephric, endothelial and steroidogenic cell migration and hence repress formation of the male-specific vasculature and Leydig cell differentiation in XX gonads (Jeays-Ward et al., 2003). *Wnt4* also appears to activate the expression of *Dax1* *in vitro* (Mizusaki et al., 2003). Another target of *Wnt4* is *Follistatin* (*Fst*). *Fst* encodes a TGF β binding protein which is thought to regulate vascular boundaries and maintain germ cell survival in the ovary (Yao et al., 2004).

Figure 1.4 summarizes the genes known to be involved in male and female pathways of testis and ovary development.

1.5 Unanswered questions

The process of mammalian sexual development involves several complex processes and coordination of these processes is vital. The majority, though not all, of the genes so far identified in this process are transcription factors that orchestrate the earliest molecular processes involved in sexual development. As the differentiation of the gonad, especially testis formation, involves a great deal of architectural changes, these cellular processes are

thought to include cell migration, cell signalling, cell adhesion, vascularisation, cell proliferation and extracellular matrix (ECM) deposition/remodelling. However, very few genes involved directly in these processes have been identified.

The vast majority of the research in this field has focused on the development of the testis. The lack of understanding of the structural changes in the ovary during the period of sex determination makes it a difficult organ to study. Clearly, ovarian tissue is differentiating from an early stage, because there are changes in the expression of genes such as *Dax1*. The discovery of new markers for the cell types present in the ovary will allow further studies to be performed on ovarian development.

Many other questions remain unanswered, for example,

1. Why does the gonad form on the ventromedial aspect of the mesonephros?
2. What is the male-specific signal for cell migration into the gonad?
3. How are XY pre-Sertoli cells able to recruit XX pre-Sertoli cells and other cell types to the male developmental pathway?
4. What is the molecular basis of the interaction between Sertoli cells and PMCs, which leads to deposition of the basement membrane and characteristic cord structure? What is the molecular basis of the nurturing interaction between Sertoli cells and PGCs? What is the

signal for PGCs to develop as spermatogonia or oocytes and how is the mitotic arrest of PGCs in male gonads achieved?

5. What are the regulatory relations between the different genes implicated in sexual development?

1.6 The search for new genes involved in sexual development

1.6.1 Criteria for screening for new genes

Many of the genes so far identified as playing a role in sexual development have been found from the analysis of known sex reversal loci in humans and by fortuitous observations of sexual abnormalities in null mutations generated in mice. One exception to this was the discovery of *Dmrt1* which was found by homology searching. These genes subsequently have been shown to display a sexually dimorphic expression pattern in the developing gonads. This raises the possibility that new genes involved in sexual development may be identified by screening for genes that are expressed in a sexually dimorphic manner in the developing gonad. Such expression screens will provide candidates whose role in sexual development can then be examined by functional analysis such as the generation of null mutations in mice or analysis in organ culture systems.

Clearly the Sertoli cells play a vital role in the development of the testis, acting as the organizing centre for the recruitment of cells in the formation of

testis cords. Thus, identifying novel gene expressed in this lineage is another important element in an expression-based screen.

A third important property to analyse in such a screen is the timing of gene expression. For example, in order to identify genes that regulate testis cord formation it is necessary to examine expression both prior to and during this time period (12.0- 13.0 dpc).

1.6.2 DNA microarray technology can be used for rapid high through-put screening

DNA microarrays have recently been used for the study of transcriptional regulation in various developmental systems (Smith and Greenfield, 2003). Microarrays provide a rapid method for expression screening of large numbers of genes.

Briefly, DNA elements (cDNA clones, PCR products or oligonucleotides – all called “probes”) are immobilised in arrays on glass slides treated with various chemicals to assist DNA adhesion. These arrays are hybridised with fluorescently labelled “targets” derived from two samples. These samples can be different tissues or the same tissue at different developmental time points.

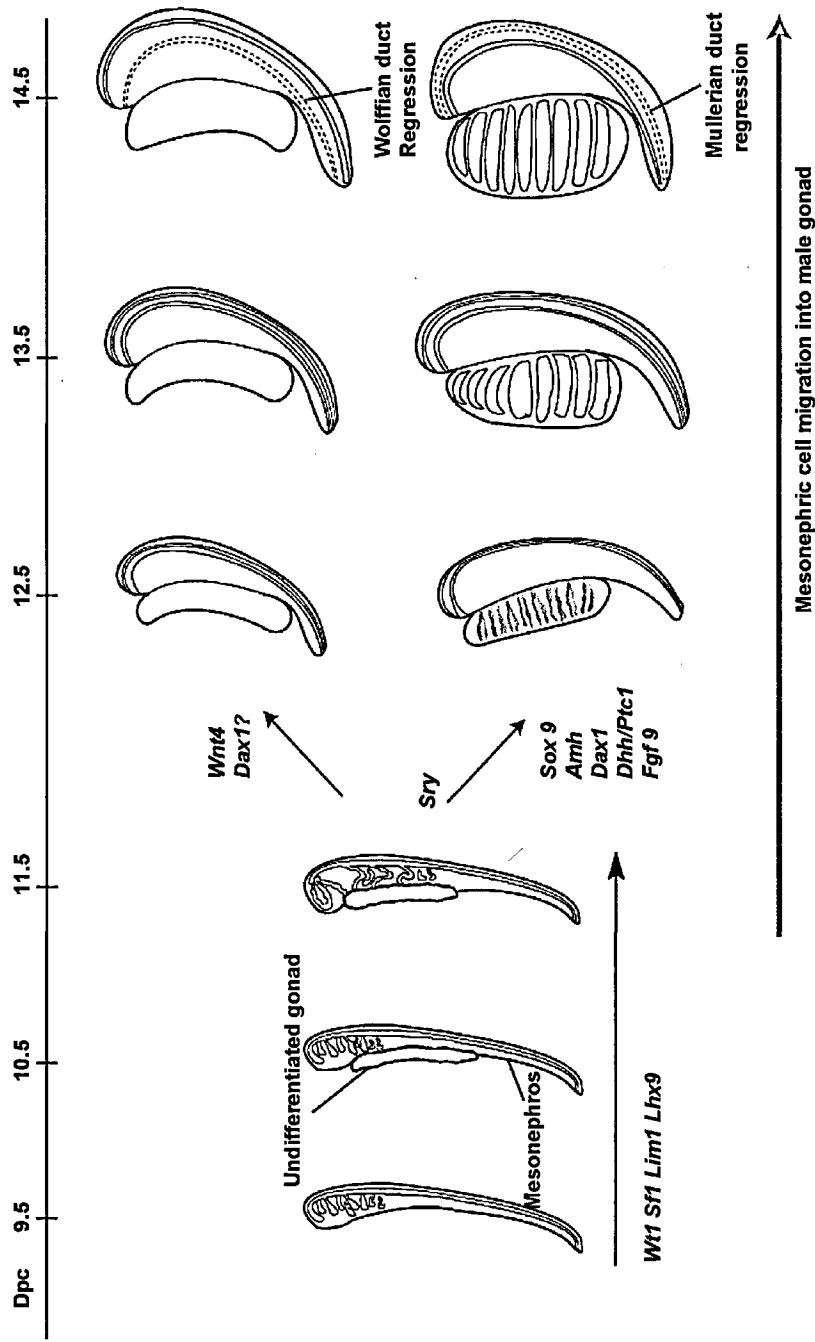

Figure 1.4

Figure 1.4 Pathways of testis and ovary development

From 9.5 to 11.5 dpc gonads of both sexes are morphologically indistinguishable. However, once the sex-determining gene *Sry* is expressed the fate of XX and XY gonads diverges. In XY gonads, under the influence of *Sry*, various male-specific genes are activated whereas in XX gonads a female-specific gene expression pathway ensues. Only a subset of genes thought to be involved is shown.

Each target is produced from RNA that is labelled by incorporation of a fluorescently tagged nucleotide (Cy3 and Cy5 are most commonly used). Recently, the advent of RNA amplification technologies has allowed smaller starting materials to be used and has increased sensitivity (Smith, 2003). Labelled target RNAs are co-hybridised to the slide. For each probe on the array, the relative expression ratio between the two samples can then be determined by measuring the relative fluorescence of Cy3/Cy5 hybridising. This measurement is achieved by scanning the hybridised slide with lasers to detect the fluorescence of each dye independently.

Microarray analysis is readily applicable to the identification of genes involved in sexual development. RNA extracted from male and female gonads may be amplified, and labelled (e.g. male with Cy5 – red, female with Cy3 – green). Following hybridisation to the array, male-enhanced elements would be identified by more Cy5 signal (red) and female-enhanced elements would be identified by more Cy3 signal (green). The elements that are up-regulated in one sex over the other could then be studied by other techniques, such as wholemount *in situ* hybridisation (WMISH), to determine which cell types the gene is expressed in. This is potentially a powerful way to identify new genes involved in sexual development.

In addition to their use in expression screens, microarrays have other advantages, as they allow semi-quantitative analyses of gene expression and facilitate multi-point analyses (analysis of expression at several time points).

This allows microarrays to be used for expression profiling, which shows the relative expression of all the genes on the array during the time course of a developmental process. This is achieved by comparing the relative expression of all genes on the array at each time point to a reference sample that remains constant in all hybridisations. As the reference is constant, it allows the indirect comparison of expression in samples over a range of time points. Alternatively, samples from different wild-type and mutant tissues could be compared to the reference sample, so allowing direct comparison of expression profiles for a known set of genes in many different mutant organs.

1.6.3 Organ culture studies can be used in further analysis

The use of *in vitro* organ culture systems has long been established in the study of gonad development, and has given great insight into how gonads develop as three dimensional structures. Many early experiments established the importance of mesonephric cell migration in order for testis cords to form, and showed that these cells were destined for the interstitium (Buehr et al., 1993a). Also, they established that cell migration into the developing gonad was male specific (Martineau et al., 1997) and depends on the expression of *Sry* (Capel et al., 1999). The origin of Sertoli cells was also found to be in the coelomic epithelium using organ culture (Karl and Capel,

1998). This was performed by injecting DiI into early gonads and following the fate of injected cells in culture.

More recent experiments have given a greater understanding into how the two pathways of testis and ovarian pathways operate. Organ culture has been used to demonstrate the importance of the presence of meiotic germ cells. Indeed the presence of the germ cells can initiate ovarian development and block testis development. *Sry* opposes this pathway by initiating testis cord formation prior to meiosis which sequesters germ cells inside the testis cords and arrests them in mitosis (Yao et al., 2003).

How various processes that are required for the development of testis cords are related and interact with each other have also been studied using organ culture techniques. Testis cord development was investigated by treating cultures with two hedgehog signaling inhibitors cyclopamine and forskolin (Yao and Capel, 2002). These inhibitors caused varying effects on gonad development in culture. Cyclopamine inhibits Smoothed, the first downstream signaling molecule after binding of Dhh to its receptor Ptc-1. When XY gonads are treated with cyclopamine in culture PGCs do not enter meiosis, and mesonephric cell migration is also unaffected. However, Leydig cell differentiation is disrupted. In contrast, Forskolin activates protein kinase A (PKA), which blocks hedgehog signaling downstream of Smoothed. When cultured gonads are treated with this inhibitor meiosis is induced in XY gonads and mesonephric cell migration is inhibited.

However, no effect on Leydig cell differentiation is observed. *In vivo* these processes normally take place in a tightly regulated sequence. However, organ culture studies have demonstrated that they can occur separately.

The use of organ culture can also be useful when the generation of null alleles results in lethality. Homozygous *Sox9* null mice die at 11.5 dpc as a result of cardiac failure which prohibits the *in vivo* analysis of the fate of XY gonads in these embryos at later stages. These gonads can be cultured and and testis cord formation studied at these later stages (Chaboissier et al., 2004).

Organ culture can also be used to study how potentially new genes play a role in the development of the testis by knocking down expression of these genes. One way to do this is to use antisense morpholino oligonucleotides (morpholinos). Morpholinos can be designed to inhibit the translation of mRNA from a target gene and are designed to be complementary, and therefore bind to, the mRNA AUG translational start site and the 22 bases 3' to that site. Translation is inhibited solely by a steric block mechanism. These compounds can be used in organ culture systems to block the function of a gene as opposed to producing mice carrying a null allele, and have the advantage of swiftness in assessing the role of a gene in gonad development. However organ culture approaches do have their limitations. For example, XY gonads when cultured do not increase in size at the same rate as *in vivo*;

and; the number of cords which form in the testis is fewer than observed *in vivo*.

1.7 Aim of this project

The aim of this project is to identify and analyse genes involved in murine sexual development. We chose to characterise genes whose expression met certain criteria as described in section 1.6.1. In males the focus of this project is to identify genes expressed in a male-specific manner in the supporting cell lineage prior to overt differentiation. Germ cells are not required for the development of the testis; however, they are required for the development of the ovary. Therefore in females, the aim of this project is to find genes expressed in a female-specific manner in any ovarian cell lineage.

Finally, one objective of this research is to identify genes acting in the sexual development pathway that belong to new functional categories, beyond transcription and growth factors.

The starting point of this project was to analyse by wholemount *in situ* hybridisation candidate genes which were found to be expressed in the mouse gonad in a sexually dimorphic fashion at 13.5 dpc using DNA microarrays.

Chapter 2: Materials and Methods

2.1 Standard solutions

All standard solutions were prepared according to Sambrook *et al.* (Sambrook *et al.*, 1989). All chemicals were obtained from Sigma/Aldrich unless stated. All restriction endonucleases were obtained from New England Biolabs unless stated.

2.2 NMUR cDNA library

A Normalised Mouse Urogenital Ridge (NMUR) cDNA library was prepared from urogenital ridges (gonad and mesonephros) dissected from 11.5 and 12.5 dpc embryos (Grimmond *et al.*, 2000). Briefly, approximately 150 pairs of 11.5 dpc UGRs were collected and sexed by amnion staining (see section 2.5.2). Poly (A)⁺ RNA was extracted from the sexed pools of tissue and equal amounts of male and female RNA were combined. This RNA was mixed with that from 12.5 dpc UGR dissections in a 3:1 ratio. A second round of poly(A)⁺ purification was performed and the library was constructed and normalised according to previously published procedures (Bonaldo *et al.*, 1996).

2.3 Isolation of plasmid DNA

2.3.1 Plasmid mini preps

10 ml of LB broth containing ampicillin (50 µgml⁻¹) was inoculated from glycerol stocks and incubated at 37 °C with shaking (200 rpm) overnight. The culture was centrifuged at 6000 x g for 10 min at 4 °C and plasmid DNA was

isolated from the pelleted cells using the High Pure Plasmid Isolation Kit (Roche), according to the manufacturer's protocol.

2.3.2 Plasmid midi preps

40 ml of LB broth containing ampicillin ($50 \mu\text{gml}^{-1}$) was inoculated from glycerol stocks and incubated at 37°C with shaking (200 rpm) overnight. The culture was centrifuged at $6000 \times g$ for 10 min at 4°C and plasmid DNA isolated from the pelleted cells using the Qiafilter Plasmid Midi Kit (Qiagen) according to manufacturer's instructions.

2.4 DNA Sample Sequencing

Plasmid DNA (350 ng) was mixed with 3.2 pmoles of sequencing primer (either T7 or T3, see appendix A) and 2 μl of ABI Prism Bigdye Cycle Sequence Ready Reaction Mix (PE Biosystems) in a total reaction volume of 8 μl . Samples were incubated in a Tetrad thermocycler (MJ Research) using the following program:

35 cycles of: 96°C 1.0 minutes (min)

step down to 50°C at 1° decrease per cycle

50°C 5.0 min

step up to 60°C 1° increase per cycle

60°C 4.0 min

Sequencing products were recovered by ethanol precipitation (Sambrook et al., 1989), washed in 70% ethanol, re-centrifuged and resuspended in 2 µl of sterile water (Analar water, BDH). Sequencing samples were then submitted to the Genotyping, Arraying and Sequencing core facility at MRC Harwell, where sequencing fragments were resolved using an ABI 377 DNA sequencer (PE Biosystems).

2.5 Embryonic tissue collection

2.5.1 Collection for wholemount *in situ* hybridisation

Timed matings of female and male breeding pairs were used to generate staged mouse embryos. Pairs were set up at approximately 3pm and females were checked for the presence of vaginal plugs on the following morning. Noon on the day of the plug was counted as 0.5 dpc. Embryos were accurately staged by counting tail somites posterior to the hindlimb bud, as follows:

Tail somites	13-16	17-21	22-24	24-26	26-28	29-37
Age: dpc	10.5-10.75	11.0-11.25	11.5-11.75	12.0-12.25	12.5-12.75	13.5

Table 2.1 Embryonic staging using tail somite numbers

Table 2.1 shows the tail somite number and corresponding age of embryos in days *post coitum* (dpc).

The following strains and crosses were used:

Female strain	Male strain	Embryos generated
C3H/HeH	101H	3H1
<i>Vanin-1</i> -/- (BALB/c)	<i>Vanin-1</i> -/- (BALB/c)	<i>Vanin-1</i> -/-
BALB/c	BALB/c	BALB/c
C3H/HeH	<i>Vanin-1</i> -/- (BALB/c)	<i>Vanin-1</i> backcross
Crm ^P /O	C3H/HeH	XO

Table 2.2 Crosses used to generate embryos for study

Table 2.2 shows the various crosses used in order to generate specific embryos used in this study.

Embryos and urogenital ridges were dissected into sterile phosphate buffered saline (PBS) containing 0.2% bovine serum albumin (BSA) and fixed in 4% paraformaldehyde/PBS overnight at 4 °C. Tissues were dehydrated using a methanol/PBS series and stored at -20 °C. As follows, all washes are at room temperature unless otherwise stated:

PBS 5 min 4 °C x 2

25% methanol/PBS 5 min

50% methanol/PBS 5 min

75% methanol/PBS 5 min

100% methanol 5 min

100% methanol. Store at -20 °C.

2.5.2 Amnion staining for embryonic sexing

Embryonic urogenital ridges collected after 12.5 dpc were sexed by the presence or absence of testis cords. Prior to 12.5 dpc, embryonic tissue was sexed by staining the amnion for the presence of Barr Bodies in XX individuals, according to Palmer and Burgoyne, 1991. Amniotic membranes were collected in 1 ml freshly made fixative (3:1 methanol: glacial acetic acid). Fixative was aspirated, 3 drops of 60% acetic acid were added and the sample was gently vortexed for 10 seconds. 1 ml of fixative was added and amniotic cells collected by centrifugation (2000 × *g* for 2 minutes). The supernatant was removed and the amniotic cells resuspended in a minimal volume of solution by gentle vortexing. 25 µl of the cell suspension was pipetted onto a clean glass slide and air dried. 1 drop of 1% toluidine blue was added to a clean coverslip and applied to the slide. XX females were identified by the presence of Barr Bodies in the nuclei of cell spreads.

2.5.3 Tissue collection for RNA extraction

Tissues were collected as described in section 2.5.1 and quickly frozen on dry ice. Samples were stored at -70 °C.

2.6 Wholemout *in situ* hybridisation

2.6.1 Riboprobe preparation

NMUR or IMAGE clones were linearised by restriction enzyme digestion as follows:

30.0 µl mini prep plasmid DNA (approximately 3 µg)

4.0 µl 10x reaction buffer

1.0 µl restriction enzyme (20 U)

5.0 µl AnalaR water

Samples were incubated for 2 hours at 37 °C. Linearised template was purified by ethanol precipitation and resuspended in 6µl AnalaR water.

Antisense digoxigenin-labelled riboprobes were synthesised as follows:

2.0 µl linearised DNA template

1.0 µl 10x RNA Polymerase Reaction Buffer (Roche)

1.0 µl 10x Digoxigenin-UTP Labelling Mix (Roche)

1.0 µl RNA polymerase (Roche)

0.5 µl RNAGuard (Pharmacia)

4.5 µl Analar water

Samples were incubated for 2 hours at 37 °C, template DNA was removed by the addition of 2 µl DNaseI (Roche). After 20 minutes at 37 °C the reaction was stopped by the addition of 2 µl 250 mM EDTA (BDH). Riboprobes were purified by ethanol precipitation and resuspended in 50 µl Analar water.

2.6.2 Wholemount *in situ* hybridisation (WMISH)

All steps were performed at room temperature for 5 minutes, unless otherwise stated.

Tissues which had previously been dehydrated (see section 2.5.1) were rehydrated using a methanol series (100%, 75%, 50%, 25% methanol/PBS) and washed twice in PBT (0.1% Tween-20 in PBS). Samples were bleached in 6% hydrogen peroxide /PBT for 1 hour and washed 3 times in PBT. Proteinase K digestion was performed using 10 μgml^{-1} Proteinase K (Roche) in PBT for 12 minutes for gonads between 10.5 and 13.5 dpc and 15 minutes for gonads between 14.5 and 15.5 dpc, and was halted with 2 washes of 2 μgml^{-1} glycine in PBT. Samples were re-fixed in 0.2% glutaraldehyde /4% paraformaldehyde/PBT for 20 minutes and washed twice in PBT. Pre-hybridisation was performed in 50% formamide (Fluka)/5x SSC pH 4.5/0.1% Tween 20/ 50 μgml^{-1} heparin at 70 °C for at least 60 minutes.

Hybridisation was performed in 50% formamide/ 5x SSC pH 4.5/0.1% Tween 20/ 50 μgml^{-1} heparin/ 100 μgml^{-1} salmon sperm DNA /100 μgml^{-1} yeast tRNA. Antisense DIG labelled riboprobes was added to each sample at a dilution of 1:200 and samples were incubated at 70 °C overnight.

Next day, samples were washed twice in Solution 1 (50% formamide/ 4x SSC/ 1% SDS) for 30 minutes. Then three washes in Solution 2 (0.5 M NaCl/10mM Tris-HCl pH 7.5/ 0.1% Tween 20). Unhybridised RNA was removed by digestion with 100 μgml^{-1} RNase in Solution 2 for 1 hour at 37°C. Samples were then washed twice for 30 minutes in Solution 3 (50% formamide/ 2x SSC pH 4.5) at 65 °C. Samples were then washed in 1x BST (140mM NaCl/ 2.7mM KCl/ 25mM MgCl_2 / 0.1% Tween 20) and pre-

blocked in 10% Heat-Inactivated Sheep Serum (HISS)/ 1x TBST for 3 hours. Samples were hybridised with Anti-Digoxigenin Alkaline Phosphatase F_{ab} fragments (Roche) (0.5 µl per ml in 1% HISS/ 1x TBST), overnight at 4 °C. Following antibody hybridisation, samples were washed 5 times in 1x TBST for at least 1 hour, and further incubated in 1x TBST overnight at 4 °C. Samples were then rinsed in NTMT (0.1M NaCl/ 0.05M Tris-HCl pH 9.5/ 0.05M MgCl₂/ 0.1% Tween 20) and then transferred to the staining solution (4.5 µgml⁻¹ NBT/3.5 µgml⁻¹ BCIP Roche/ NTMT). Samples were kept in the dark during colour development, after which they were fixed in 4% paraformaldehyde/ PBS.

2.6.3 Photography and sectioning

Following WMISH, tissues were photographed on 0.5% agarose/PBS using a photomicroscope (Nikon) with Fuji 64T film. They were then frozen in OCT compound (BDH) and sections were cut at 16 microns thickness on a cryostat (Leica). Bright-field photographs were taken using an Axiophot (Zeiss) with a digital camera.

2.7 *In situ* hybridisation to frozen sections

2.7.1 Single probe *in situs*

This protocol was adapted from Strahle et.al (Strahle et al., 1994). Freshly dissected gonads were fixed overnight in 4% PFA/PBS at 4 °C. Next day

they were embedded in 1.5% agarose/ 5% sucrose/ PBS. These blocks were trimmed and re-embedded in 30% sucrose and frozen on dry ice. 10 μ m sections were cut on a cryostat, transferred to clean slides, air-dried for 30 minutes, and stored at -20 °C until required.

The riboprobe (or mixture of probes see section 2.7.2) was diluted 1:200 in hybridisation buffer (see section 2.7.3), denatured at 70 °C for 5 mins and 100 μ l added to each defrosted slide. These were hybridised overnight at 65°C in a humidified container.

Next day, sections were washed as follows:

1 x 15 mins 65 °C Solution A (see section 2.7.3)

1 x 30 mins 65 °C Solution A

2 x 30 mins 1 x TBST room temp

1 x 60 mins 10% HISS/ 1 x TBST room temp.

Anti-Digoxigenin Alkaline Phosphatase F_{ab} fragments were diluted 1:2000 in 0.5 ml 10% HISS/ 1 x TBST and added to the slides, which were incubated overnight at 4 °C.

Next day slides were washed as follows:

4 x 20 min 1 x TBST

2 x 10 min NTMT

Sections were stained in the dark in 4.5 μ l NBT + 3.5 μ l BCIP/ml NTMT.

After colour development had sufficiently proceeded, the reaction was stopped by washing the slides twice in distilled water, and post fixed in 4% paraformaldehyde.

Sections which were treated with a single riboprobe were then mounted under coverslips using Aquamount (BDH) and photographed using an Axiophot with a digital camera.

2.7.2 Section *in situ* hybridisation with two probes

In sections where the expression of two different genes was to be analysed, one probe was labelled with digoxigenin and the other with fluoroscein. Labeling with fluoroscein was performed in the same manner as for digoxigenin (see section 2.6.1).

Sections were treated as for digoxigenin labelled single probes, then fixed in 4% paraformaldehyde for 20 minutes. They were then washed in 1 x TBST, pre-blocked in 10% HISS/ 1x TBST for at least one hour at room temperature. Sections were then treated with a 1:8000 dilution of anti-fluoroscein alkaline phosphatase F_{ab} fragments in 10% HISS/1x TBST overnight at 4 °C.

Next day slides were rinsed five times in 1 x TBST for 20 minutes, followed by 2 x 10 minute washes in NTMT pH 8.0. One tablet Fast Red/ml NTMT was used for the colour development, which was done at room temperature in the dark. The reaction was stopped by rinsing in water, and the sections

mounted under coverslips in Aquamount and again photographed using an Axiophot with a digital camera.

2.7.3 Solutions

10 x Salt per litre:	NaCl	114 g
	Tris HCL	14.04 g
	Tris base	1.34 g
	NaH ₂ PO ₄ ·H ₂ O	7.8 g
	Na ₂ HPO ₄	7.1 g
	0.5M EDTA	100 ml

Hybridisation buffer: 1 x Salt, 50% formamide, 10% dexran sulphate, 1 mgml⁻¹, 1x Denhardts.

Solution A: 1x SSC, 50% formamide, 0.1% Tween-20.

2.8 Genomic DNA extraction

2.8.1 Using Phenol:Chloroform

Embryo carcasses were incubated overnight at 55°C in 700 µl of PK Buffer (50 mM Tris-HCl pH 8 / 100 mM EDTA / 0.5% SDS) with 35 µl of 10 mgml⁻¹ proteinase K (Roche). Following digestion, 700 µl of phenol:chloroform (50:50 v/v) was added and samples were mixed by rotation at room temperature for 10 minutes. After centrifugation (5 minutes at 21000 x g at room temperature), the upper (aqueous) phase was removed and subjected to a second phenol:chloroform extraction followed by a chloroform

extraction (performed as detailed above). Genomic DNA was precipitated by the addition of 600 μ l isopropanol to the aqueous phase and was collected by brief centrifugation at 21000 \times g at room temperature. The DNA precipitate was washed with 70% ethanol and resuspended in 200 μ l AnalaR water. Aliquots of the genomic DNA solution were used for genotyping PCR or Southern analysis (see Sections 2.17.2 and 2.9).

2.9 Southern blotting

Genomic DNA was digested as follows:

20 μ g genomic DNA

10 μ l relevant 10x Reaction Buffer

7 μ l relevant restriction endonuclease

AnalaR water to 100 μ l

Incubate overnight at 37 $^{\circ}$ C

Restriction fragments were ethanol precipitated and resuspended in 18 μ l of water. Following the addition of 2 μ l of loading dye the restriction fragments were resolved by gel electrophoresis in a 0.8% agarose / 1x TAE gel run overnight at 30 V. Loading dye consisted of 40% sucrose, 0.03% bromophenol blue, 0.3% xylene cyanol FF and was used in order to keep the samples in the wells and to track the DNA as it migrated through the agarose.

The gel was photographed, then depurinated by washing with agitation in 0.25 M HCl (BDH) for 30 minutes at room temperature. DNA in the gel was then denatured by washing in 0.4 M NaOH (BDH) for 30 minutes at room temperature. DNA fragments in the gel were transferred to a nylon membrane (HybondTM-N+ - (Amersham)) by capillary blotting using 0.4 M NaOH, as described in the manufacturer's instructions. After blotting overnight, the nylon membrane was rinsed in 2x SSC. Membranes were stored at -20°C until required for hybridisation.

2.10 Radioactive hybridisations

2.10.1 Radioactive probe preparation

Probes were labelled by incorporation of ³²P- α -dCTP (Amersham) using the Megaprime DNA labelling system (Amersham) according to the manufacturer's instructions. Unincorporated radionuclides were removed using a Microspin S-400 HR column (Amersham), according to the manufacturer's instructions.

2.10.2 Membrane hybridisation

Prior to hybridisation, each nylon membrane was prehybridised for at least 1 hour at the relevant temperature in 10 ml of ExpressHyb solution (Clontech). Radio-labelled DNA probe was denatured at 95 °C for 5 minutes, chilled on ice for 3 minutes and added to 10 ml of ExpressHyb solution (Clontech). The

prehybridisation solution was replaced with the hybridisation solution, containing the labelled probe, and hybridisation was performed for 1 hour at 60 °C. All membranes were washed according to the ExpressHyb user protocol. After washing, membranes were wrapped in Clingfilm and placed on autoradiographic film (Kodak) at -70 °C overnight or until sufficiently exposed. Autoradiographs were developed using an X-ograph developer. Following hybridisation and signal development, membranes were stripped of the radioactive probe by heating in 0.1% SDS at 94°C for 10 minutes and were stored at -20 °C.

2.11 Total RNA isolation

Total RNA was isolated using the Qiagen RNeasy Mini Kit in conjunction with the QiaShredder Homogenisation Column (Qiagen) according to the manufacturer's protocols. Total RNA was eluted in a final volume of 30 µl RNase-free water (Qiagen) and was stored at -70 °C until required.

2.12 Polymerase Chain Reaction (PCR)

PCR reactions were set up as follows:

3 µl 10x PCR Reaction Buffer including final MgCl₂ concentration of 1.5 mM

1.5 µl 4 mM dNTP mix (ABgene)

1.0 µl Forward amplification primer (10 µM)

1.0 μ l Reverse amplification primer (10 μ M)

1.0 μ l Template DNA (approx. 1-5 ng)

0.2 μ l *Taq* DNA polymerase (ABgene)

Reaction volumes were adjusted to 30 μ l with sterile water and samples were incubated in a Tetrad thermocycler (MJ Research) according to the following regime:

30 cycles of 94 °C 3.0 minutes

55 °C 2.0 minutes

72 °C 3.0 minutes

Final step 72 °C 1.0 minute

Typically, a 55 °C annealing temperature was used; however, certain primer pairs required higher annealing temperatures (see Appendix A- for details).

2.13 Reverse Transcription PCR (RT-PCR)

First strand cDNA was synthesised using the Superscript II Reverse Transcriptase Kit (Invitrogen) according to the manufacturer's instructions.

Subsequent PCR reactions were set up as follows:

5.0 μ l 10x PCR reaction buffer including a final MgCl₂ concentration of 1.5 mM

2.5 μ l 4 mM dNTP mix (ABGene)

1.0 μ l amplification primer 1 (10 μ M)

1.0 μ l amplification primer 2 (10 μ M)
1.0 μ l *Taq* DNA polymerase (5 U – ABGene)
2.0 μ l cDNA (from first strand reaction)
37.5 μ l Analar water

PCR was performed in a Tetrad thermocycler (MJ Research) according to the protocol detailed in the previous section.

2.14 Analysis of P1-derived Artificial Chromosome (PAC) clones

2.14.1 Isolation of PAC DNA

400 ml of LB broth containing 250 μ l chloramphenicol (25 mgml⁻¹) was inoculated from a single colony of the PAC clone. The culture was grown for 20 hours at 37°C with shaking at 200 rpm. Bacterial cells were collected by centrifugation at 15000 x g for 10 minutes. The cells were resuspended in 20 ml of 10 mM EDTA and kept at room temperature for 5 minutes. 40 ml of 0.2 M NaOH / 1% SDS was added, the solution mixed by inversion and kept at room temperature for 5 minutes. 30 ml of Solution 3 (1.875 M KOAc, 11.5% Acetic acid (v/v)) was added and the mixture incubated on ice for 10 minutes. Cellular debris was collected by centrifugation at 15000 x g for 20 minutes at 4 °C. The supernatant was filtered through sterile gauze and DNA was precipitated by addition of 45 ml isopropanol.

Precipitated DNA was collected by centrifugation at 15000 x g for 20 minutes at 4 °C. The precipitate was resuspended in 9 ml 1x TE pH 8 and 4.5 ml 7.5 M

KOAc was added. The sample was stored at $-70\text{ }^{\circ}\text{C}$ for 30 minutes, thawed and centrifuged at $5000 \times g$ for 10 minutes at $4\text{ }^{\circ}\text{C}$. 27 ml of absolute ethanol was added to the supernatant and the sample kept on ice for 10 minutes. Precipitated DNA was collected by centrifugation at $5000 \times g$ for 10 minutes and resuspended in $700\text{ }\mu\text{l}$ $1\times$ TE pH 8.

RNA in the sample was removed by digestion with $10\text{ }\mu\text{l}$ of RNase A (10 mgml^{-1}) at $37\text{ }^{\circ}\text{C}$ for 30 minutes. $700\text{ }\mu\text{l}$ of phenol:chloroform (50:50 v/v) was added and the sample inverted gently for 2 minutes at room temperature. Phases were separated by centrifugation at $21000 \times g$ for 2 minutes at room temperature. The aqueous phase was reserved and an equal volume of chloroform was added. This mixture was again inverted for 2 minutes at room temperature and centrifuged at $21000 \times g$ for 2 minutes. The aqueous phase was removed to a fresh tube and an equal volume of isopropanol was added. The sample was mixed by inversion and precipitated DNA was collected by centrifugation at $21000 \times g$ for 5 minutes at $4\text{ }^{\circ}\text{C}$. The precipitate was washed with $700\text{ }\mu\text{l}$ ethanol and centrifuged at $21000 \times g$ for 2 minutes. Finally, the DNA precipitate was resuspended in $100\text{ }\mu\text{l}$ AnalaR water.

2.14.2 Digestion of PAC DNA

PAC DNA was digested as follows:

$6.0\text{ }\mu\text{l}$ PAC DNA

$3.0\text{ }\mu\text{l}$ relevant $10\times$ reaction buffer

3.0 μl BSA (where necessary, according to manufacturer's notes)

1.0 μl relevant restriction endonuclease

The volume of each sample was adjusted to 30 μl with sterile water and samples were incubated at 37 °C for 2 hours. DNA fragments were resolved by gel electrophoresis in a 0.8% agarose / 1x TAE gel run at 10 Volts cm^{-1} .

DNA fragments containing the gene of interest were identified by Southern hybridisation (see Section 2.9).

2.15 Plasmid digests and DNA ligations

2.15.1 Plasmid DNA digestions

Mini-prep plasmid DNA digestions were set up as below:

10.0 μl Plasmid DNA (approx. 1.0 μg)

3.0 μl relevant 10x Reaction Buffer

3.0 μl 10x BSA (if required)

1.0 μl relevant restriction endonuclease (20 U μl^{-1})

Sample volumes were adjusted to 30 μl with Analar water and samples were incubated at the relevant incubation temperature for 2 hours. DNA fragments were resolved by agarose gel electrophoresis following standard techniques (Sambrook et al., 1989).

2.15.2 PCR product ligation

PCR products were ligated into a cloning vector using the pGEM-T-Easy kit (Promega) following the manufacturer's instructions.

2.15.3 Isolation and purification of DNA fragments

The DNA fragment of interest was generated by restriction digestion as detailed previously (Section 2.14). The fragment was resolved by agarose gel electrophoresis and the relevant band was excised in a minimum of agarose. DNA from this gel slice was isolated using the QiaQuick Gel Extraction kit (Qiagen) following manufacturer's instructions.

Where necessary, fragment cohesive ends were blunted using the Klenow fragment of DNA polymerase I in the following reaction:

10.0 μ l DNA fragment of interest

2.0 μ l 10x EcoPol reaction buffer (New England Biolabs)

0.3 μ l 2 mM dNTP mix

1.0 μ l Klenow DNA polymerase fragment (New England Biolabs)

The reaction volume was adjusted to 20 μ l with AnalaR water (BDH) and samples were incubated at room temperature for 15 minutes. After this time, the reaction was quenched by the addition of 2 μ l of EDTA (250 mM) and heating to 65 °C for 10 minutes.

2.15.4 Preparation of cloning vector

The cloning vector (typically pBluescript – Stratagene) was digested with the relevant restriction enzyme and the cut vector was purified by gel extraction as detailed above (Section 2.14). The purified vector was then treated with

shrimp alkaline phosphatase (SAP - Amersham) to remove 5' phosphate groups and prevent vector re-ligation:

5.0 μl purified, cut vector

0.2 μl Shrimp alkaline phosphatase

2.0 μl 10x SAP reaction buffer

Reaction volumes were adjusted to 20 μl with AnalaR water and samples were incubated at 37 °C for 1 hour. The enzyme was inactivated by the addition of 2 μl EDTA (250 mM) and incubation at 65 °C for 15 minutes.

2.15.5 Ligation reactions

For each experimental ligation, positive and negative controls were performed. Positive controls contained vector (and insert) that had not been SAP treated, negative controls contained SAP treated vector but no insert. All DNA ligations were performed with an insert: vector ratio of 3:1, estimated from visualisation on agarose electrophoresis. Experimental ligations were prepared as below:

2.0 μl SAP-treated vector

1.0 μl 10x T4 DNA ligase reaction buffer (New England Biolabs)

0.5 μl T4 DNA ligase (New England Biolabs)

3.0-6.0 μl purified insert DNA (depending on concentration)

Ligation volumes were adjusted to 10 μl with AnalaR water and samples were incubated at 15 $^{\circ}\text{C}$ overnight. Following this, the ligase was inactivated by incubation at 65 $^{\circ}\text{C}$ for 15 minutes.

2.16 Transformation of *E.coli* with ligated plasmids

2.16.1 Heat-shock transformation:

CaCl_2 competent cells (30 μl , *E. coli* strain DH5 α , Invitrogen) were mixed with 10 μl of the ligation reaction and kept on ice for 30 minutes. Cells were then heat-shocked by incubation at 42 $^{\circ}\text{C}$ for 90 seconds. The cells were chilled on ice for 2 minutes and 350 μl of SOC medium (Sambrook et al., 1989) was added. The sample was incubated at 37 $^{\circ}\text{C}$ with shaking (180 rpm) for 1 hour to allow expression of the ampicillin resistance gene. 10 μl and 50 μl aliquots of the transformation sample were then spread on LB-Agar plates containing 50 μgml^{-1} ampicillin. Plates were incubated overnight at 37 $^{\circ}\text{C}$.

2.16.2 Electroporation transformation:

Ligated DNA was precipitated by the addition of 1 μl 3M NaOAc pH 4.8 and 25 μl absolute ethanol to the ligation reaction and was chilled to -70 $^{\circ}\text{C}$ for 30 minutes. Precipitated DNA was collected by centrifugation at 21000 $\times g$ for 20 minutes at 4 $^{\circ}\text{C}$. The precipitate was washed with 500 μl 70% ethanol and resuspended in 4 μl sterile water. 2 μl of the resuspended DNA was placed in a chilled electrocuvette (Biorad) on ice. 15 μl of electro-competent cells (*E.*

coli strain DH5 α) were added and the cuvette was kept on ice for a further minute. The cuvette was transferred to an electroporator (Biorad) and pulsed at 1.8 kV. 300 μ l of ice-cold SOC medium was added and the sample incubated at 37 °C with shaking (180 rpm) for 1 hour. Aliquots of each sample (10 and 50 μ l) were then spread on LB-Agar plates containing 50 μ gml⁻¹ ampicillin and incubated at 37 °C overnight.

2.17 LacZ reporter construct analysis

2.17.1 Transgenic mouse generation

A *LacZ* reporter construct containing the DNA sequence of interest placed upstream was generated by standard cloning techniques (detailed in Section 2.15). The reporter construct was liberated from vector DNA by digestion with the relevant restriction endonucleases (see Chapter 5). The construct was purified by gel extraction using the Qiagen Gel Extraction kit, following the manufacturer's protocol. Final elution was performed with 30 μ l of 10 mM Tris-HCl, pH 8.5. DNA concentration was estimated by visual inspection following gel electrophoresis. 0.5 M EDTA was added and the construct eluate was diluted to give a final concentration of 5.0 ng μ l⁻¹ in 10 mM Tris-HCl / 0.1 mM EDTA. The construct was submitted to the Transgenic Facility at MRC Harwell, where it was injected into pronuclei derived from F1 matings (strain CBA x C57BL/6). Injected pronuclei were transferred to pseudopregnant recipient females (strain CBA x C57BL/6). At

3 weeks of age, tail biopsies were taken from the progeny. Genomic DNA was isolated and used in genotyping PCR reactions as detailed previously.

2.17.2 Genotyping transgenic mice

Genomic DNA was isolated from transgenic tail tips as described above (Section 2.8). Genotyping was performed by PCR as follows:

2.0 μ l 10x PCR reaction buffer including final Mg^{2+} concentration of 1.5 mM

1.0 μ l 4 mM dNTP mix

1.0 μ l forward genotyping primer (15 μ M)

1.0 μ l reverse genotyping primer (15 μ M)

1.0 μ l genomic DNA (1:1000 dilution)

0.5 μ l *Taq* DNA polymerase (ABgene)

Sample volumes were adjusted to 20 μ l by addition of sterile water and samples were incubated in a Tetrad thermocycler (MJ Research) according to the following protocol:

35 cycles of: 94 °C 30 seconds

55 °C 1.0 minute

72 °C 1.0 minute

Final step 72 °C 2.0 minutes

The genotyping primers used are listed in Appendix A. PCR products were resolved by gel electrophoresis at 10 Vcm⁻¹ in a 1% agarose / 1x TAE gel.

2.17.3 X-Gal staining of transgenic embryos

Embryonic tissue was collected as previously detailed. Part of the embryo was stored at -70 °C for genotyping purposes. The remainder was rinsed in 1x PBS. The sample was then fixed in Fix solution (0.2% glutaraldehyde / 2 mM MgCl₂ (BDH) / 5 mM EGTA in 0.1 M sodium phosphate buffer pH 7.3) for 30 minutes at 4 °C. Samples were then washed three times for 2 minutes each at room temperature in Wash solution (2 mM MgCl₂ / 0.1% sodium deoxycholate / 0.02% Nonidet P40 (BDH) / 0.05% (w/v) bovine serum albumin in 0.1 M sodium phosphate buffer pH 7.3).

The wash solution was then replaced with 1 ml of Stain solution (41 mg potassium ferricyanide, 52.5 mg potassium ferrocyanide (both BDH) in 24 ml of Wash solution with 1 ml of 25 mgml⁻¹ X-Gal (5-bromo-4-chloro-3-indolyl β -D-galactopyranoside) in dimethyl sulphoxide). Samples were then incubated at 37 °C in the dark. Once sufficient staining had developed, samples were washed twice in Wash solution and stored in Fix solution at 4 °C in the dark. Samples were photographed on agarose as detailed above (Section 2.6.3).

2.18 Organ Culture

Timed matings of female and male breeding pairs were used to generate staged mouse embryos. Three different mating pairs were used, female

(C3H/HeH) and male (101), female and male BALB/c, and female and male mice homozygous for the *Vanin-1* null allele, henceforth known as the *Vanin-1* null. Pairs were set up as described in section 2.5.1. For organ culture urogenital ridges comprising the gonad and attached mesonephros were dissected into PBS at the 17-20 tail somite stage corresponding to 11.0-11.25 dpc (see table 1), prior to testis cord formation in males. The sex of each embryo was determined by staining the amnion for the presence of Barr bodies as in section 2.5.2. Organ culture was performed as essentially described in Martineau et al (1997). Briefly, dissected urogenital ridges were stored in Dulbecco's Minimal Eagle's Medium (DMEM)/ 10% fetal calf serum (FCS)/ 50 μgml^{-1} ampicillin/ 200mM L-glutamine, for a short time in individual dishes whilst the embryonic sex was determined. Single male urogenital ridges (comprising one gonad-mesonephros pair) were then placed into grooves on 1.5% agar blocks incubated in 35mm culture dishes containing 0.4 ml DMEM/FCS/ 50 μgml^{-1} ampicillin/ 200 mM L-glutamine. Organs were cultured at the air/medium interface at 37°C in 5% CO₂. Culture medium was changed after 24 hours. Experimental cultures contained 50 μgml^{-1} anti-Vanin-1 mAb 407 dissolved in the culture medium. One gonad-mesonephros pair from each embryo was also treated as a control and cultured in the absence of mAb 407 or, in some experiments, in the presence of a distinct mAb contained in the control culture medium. After 48 hours urogenital ridges were scored for the presence or absence of

testis cords and then either fixed in 4% paraformaldehyde for subsequent WMISH or freshly frozen in OCT for immunohistochemical analysis.

2.19 Immunohistochemistry

2.19.1 Sample preparation

Tissues were freshly frozen in OCT compound and cryosections cut at 10 μm , air dried and fixed for 15 minutes in ice-cold acetone. Sections could then be used directly, or stored at $-20\text{ }^{\circ}\text{C}$ until required.

2.19.2 Laminin, mAb 407, and mAb 31.9 detection

Sections were rinsed in PBGT (0.5% gelatine/0.05% Tween 20 in PBS) for 3 x 5 minutes, and then incubated with $10\text{ }\mu\text{gml}^{-1}$ mAb 407, mAb 31.9 (P.Naquet) or rat anti-mouse laminin A chain (Chemicon), in PBGT for 45 minutes at room temperature. They were then washed 3 x 5 minutes in PBGT, and incubated in rabbit anti-mouse FITC IgG (Chemicon) at a 1:100 dilution in PBGTN (PBGT + 5% HISS) for 45 minutes at room temperature. After rinsing in PBGT, sections were mounted under coverslips in Vecta Shield (Vecta Laboratories Inc) and photographed under ultraviolet light using an Axiophot microscope.

2.19.3 p75NTR Detection

This was performed essentially as described by Russo et al (1999). Slides were thawed for 20 minutes and pre-blocked in 10%FCS/PBS for 30 minutes at room temperature. They were then incubated in rabbit anti-mouse p75 receptor polyclonal antibody (Chemicon) at a 1:200 dilution in 0.1%/BSA/PBS for 30 minutes again at room temperature. After 3 x 5 minute PBS washes, slides were incubated in goat anti-rabbit IgG FITC at a 1:100 dilution in 0.1% BSA/PBS for 45 minutes at room temperature. Slides were then rinsed in PBS and mounted under coverslips in Vecta Shield and photographed as in section 2.18.2.

2.19.4 Alkaline phosphatase staining

In order to verify that immunostaining was being performed on sections containing testis cords, alternate sections were taken and stained for the presence of germ cells using alkaline phosphatase staining. Sections were washed 3 x in NTMT pH 9.5, and then incubated in the dark in 4.5 µl NBT + 3.5 µl BCIP/ml NTMT for 10 minutes. They were then rinsed in NTMT and PBS and mounted under coverslips in Aquamount.

2.19.5 PECAM staining

Purified rat anti-mouse CD31 (PECAM-1) (BD Pharmingen) monoclonal antibody was used in order to detect migratory endothelial cells. Gonads

were embedded on OCT and cryosections cut at 10 µm thickness. After a ten minute acetone fixation sections were incubated in 3% hydrogen peroxide in isopropanol, then in 10% rabbit serum (DakoCytomation). Sections were then incubated in PECAM-1 mAb (1:10) for one hour in 10% rabbit serum. Visualisation was performed *via* a three-step staining procedure initially using biotinylated rabbit anti-rat polyclonal antibody incubation (1:400) for 30 minutes as a secondary antibody (BD Pharmingen). A streptavidin -HRP tertiary antibody was then used in conjunction with the ChemMate detection kit Peroxidase/DAB Rabbit/Mouse (DAKO). Slides were then counterstained with Haematoxylin and mounted under coverlips with Aquamount.

Chapter 3: Expression analysis of candidate genes using wholemount *in situ* hybridisation

3.1 Introduction

In the mammalian testis development pathway, the supporting (Sertoli) cell lineage plays a critical role. Studies of XX \leftrightarrow XY chimeras (Burgoyne et al., 1988; Palmer and Burgoyne, 1991) suggest that they are the initial site of the Y-linked sex determining signal. Pre-Sertoli cells express the Y-linked sex determining gene *Sry* around 10.5 dpc (Hacker et al., 1995a). The presence of *Sry* is thought to initiate the expression of other testis-determining genes. Over the next 48 hours the testis develops a distinctive morphology under the control of *Sry*, due to the promotion of various cellular processes, for example, cell signalling, migration, and proliferation, tissue remodelling and vascularisation. Most genes found thus far to play a role in testis development have encoded transcription factors: *Sox9* (da Silva et al., 1996; Kent et al., 1996) (Swain et al., 1996), *Sf1* (Shen et al., 1994), *Dmrt1* (Raymond et al., 1999)), or signalling molecules (*Amh* (Behringer et al., 1994), *Dhh* (Bitgood et al., 1996) *Fgf9* (Colvin et al., 2001)). One major feature of all these genes is that they are thought to display a sexually dimorphic expression pattern in the developing testis and are expressed in the Sertoli cell lineage. Clearly, the above list is restricted to two broad functional groups; given the diversity of cellular processes involved in gonad development other genes must be functioning which have not yet been identified. Additionally, no known target genes of these transcription factors have been identified so far, though new candidate genes continue to be discovered (McClive et al., 2003).

In the developing ovary at equivalent stages, using light microscopy, the morphological organisation is less well defined than in the testis. For this reason it is more difficult to determine the cell type expressing any particular gene. Few ovarian determining genes are known, although using various tools, for example gain/loss of function studies, two genes, *Dax1* and *Wnt4*, have been shown to be important (Mizusaki et al., 2003; Swain et al., 1998). In contrast to the testis, primordial germ cells (PGCs) are required for ovarian development. PGCs are required for the differentiation of follicle cells; in the absence of PGCs follicles never form (Bedell et al., 1995; Huang et al., 1993). In contrast, Sertoli cell differentiation and testis cord formation are not dependent upon the presence of PGCs.

The aim of this chapter is to analyse in detail the expression of candidate genes which have arisen from a DNA microarray-based screen for sexually dimorphic transcripts at 13.5 dpc. This validation is performed by wholemount *in situ* hybridisation (WMISH). The objective with respect to male development is to identify sexually dimorphic transcripts specifically in the pre-Sertoli cell lineage, before overt differentiation of the testis, in order to attempt to expand the list of functional classes known to be important in male sexual development. In females, given the paucity of known ovarian determining genes, a lesser knowledge of the morphology of the developing ovary, and the fact that PGCs are known to play a role in

ovarian development, any gene observed to exhibit an ovarian-specific expression pattern is of interest.

3.2 Objectives

- To validate the sexually dimorphic expression of candidate genes arising from DNA microarray experiments.
- To identify cell type specificity of expression, and in males, to identify potential Sertoli cell expression using the Sertoli cell marker *Sox9* for comparison.
- To choose potential genes which may expand the list of functional classes known to be important in sexual development.

3.3 DNA Microarrays

A key feature of genes previously shown to be involved in sex determination is that they were found to exhibit sexually dimorphic expression during gonadogenesis (for reviews see: Capel, 2000; Greenfield and Koopman, 1996; Swain and Lovell-Badge, 1999). DNA microarray technology provides a rapid means of screening large numbers of genes for differences in gene expression between two tissues. This technique was therefore exploited in order to identify additional genes exhibiting sexually dimorphic expression. Three different probe sources were used, either from the NMUR cDNA library (Grimmond et al., 2000), from the Ko developmental gene collection (Ko et al., 2000) or from the Mouse Known Gene SGC Oligo Set Array 2

(www.hgmp.mrc.ac.uk). This last array uses a commercial oligonucleotide library designed by Compugen. These microarrays also contained genes which are known to be expressed in gonad development in a sexually dimorphic manner, and therefore could be used as useful internal controls for the hybridisations.

These microarrays were hybridised to fluorescently-labelled cDNA targets made from 12.5 and 13.5 dpc dissected gonads, as the transcripts of most early onset sexually dimorphically expressed genes are still detectable at these stages. Microarray hybridisations and data analyses were performed by Sean Grimmond (Grimmond et al., 2000) and Lee Smith (Smith, 2003).

3.4 Results

3.4.1 Candidate clones

Seven clones were obtained for further study because they exhibited significant sexually dimorphic expression on DNA microarrays in replicate experiments (Table 3.1).

Gene	Accession Number	Microarray	Expression
<i>Adh 4</i>	NM_011996	NMUR	MALE ENHANCED
<i>Mod-1</i>	NM_008615	KO-SET	MALE ENHANCED
<i>Hey2</i>	NM_013904	NIA/OLIGO	MALE ENHANCED

<i>Cbln1</i>	NM_019626	NIA/OLIGO	MALE ENHANCED
<i>Slc20a1</i>	NM_015747	NIA/OLIGO	MALE ENHANCED
<i>Gata2</i>	NM_008090	NMUR	FEMALE ENHANCED
<i>Vanin-1</i>	NM_011704	NMUR	MALE ENHANCED

Table 3.1 Candidate clones

Table 3.1 shows candidate clones chosen for further analysis after initial microarray data suggests they exhibit sexually dimorphic expression and hence may play a role in gonad development. Each candidate is listed along with its accession number, library and initial expression data.

For each candidate clone, riboprobes were synthesised according to the vector used in each library (Table 3.2).

Library	Vector	Linearise	Antisense Riboprobe
NMUR	pT7T3	<i>ECORI</i>	T3RNA Polymerase
KO SET	pSPORT	<i>SALI</i>	SP6RNA polymerase
NIA/OLIGO	pSPORT	<i>SALI</i>	SP6RNA polymerase

Table 3.2 Riboprobe synthesis

Table 3.2 shows how each riboprobe was synthesised according to its original library.

Wholemount *in situ* hybridisation (WMISH) was performed with each probe. Initially, male and female gonads were dissected at 12.5 and 13.5 dpc, because at these stages the testis cords in the male are clearly visible facilitating the identification of the cell-type expressing each gene. As stated previously, the identification of ovarian cell-types expressing a given gene is more difficult.

3.4.2 Alcohol Dehydrogenase Class IV, (*Adh 4*) expression is enhanced in the developing male gonad

Alcohol dehydrogenase has been shown to be an enzyme that metabolises retinoids to produce their active forms (Duester, 2000). WMISH performed on male and female gonads at 12.5 dpc and 13.5 dpc confirmed initial microarray data, indicating an enhancement of expression in the developing male gonad (Figure. 3.1A, 3.1B).

Upon longitudinal sectioning of these gonads, it can be seen that expression of *Adh4* exhibits a similar pattern to that of *Sox9*, namely it is confined to the periphery of the testis cords in the vicinity of Sertoli cells (Figure. 3.1C and D).

3.4.3 Malic Enzyme-1 (*Mod-1*) shows male-enhanced expression in the developing gonad

Mod-1 encodes a metabolic enzyme which catalyses the reversible oxidative decarboxylation of malate, and is a link between the glycolytic pathway and

the citric acid cycle. It is cytosolic, and has previously been shown to be expressed in the liver (Johnson et al., 1981). WMISH using a *Mod-1* riboprobe at 12.5 dpc and 13.5 dpc again reveals male-enhanced expression (Figure.3.2A and B). This expression is again located around the edges of the testis cord in a similar pattern to that of *Sox9* at 13.5 dpc (Figure.3.2C).

3.4.4 Hairy/enhancer of split-related protein with YRPW motif 2 (*Hey2*) expression is enhanced in the male gonad at 13.5 dpc

Hey2 is a member of a novel subfamily of hairy/Enhancer of split (E(spl))-related genes. Whereas hairy/E(spl) proteins are characterized by an invariant proline residue in the basic domain and a carboxyterminal groucho-binding WRPW motif, *Hey* genes encode a carboxyterminal YRPW sequence. *Hey2* is expressed in the developing somites, heart, craniofacial region and the nervous system in the mouse embryo (Leimeister et al., 1999). At 13.5 dpc *Hey2* expression is confirmed as sexually dimorphic with up-regulation in the male. Transcripts are located in the interstitial area of the testis, the site of Leydig, endothelial and peritubular myoid cells. Expression is not observed in the Sertoli cells. (Figure 3.3 A and B).

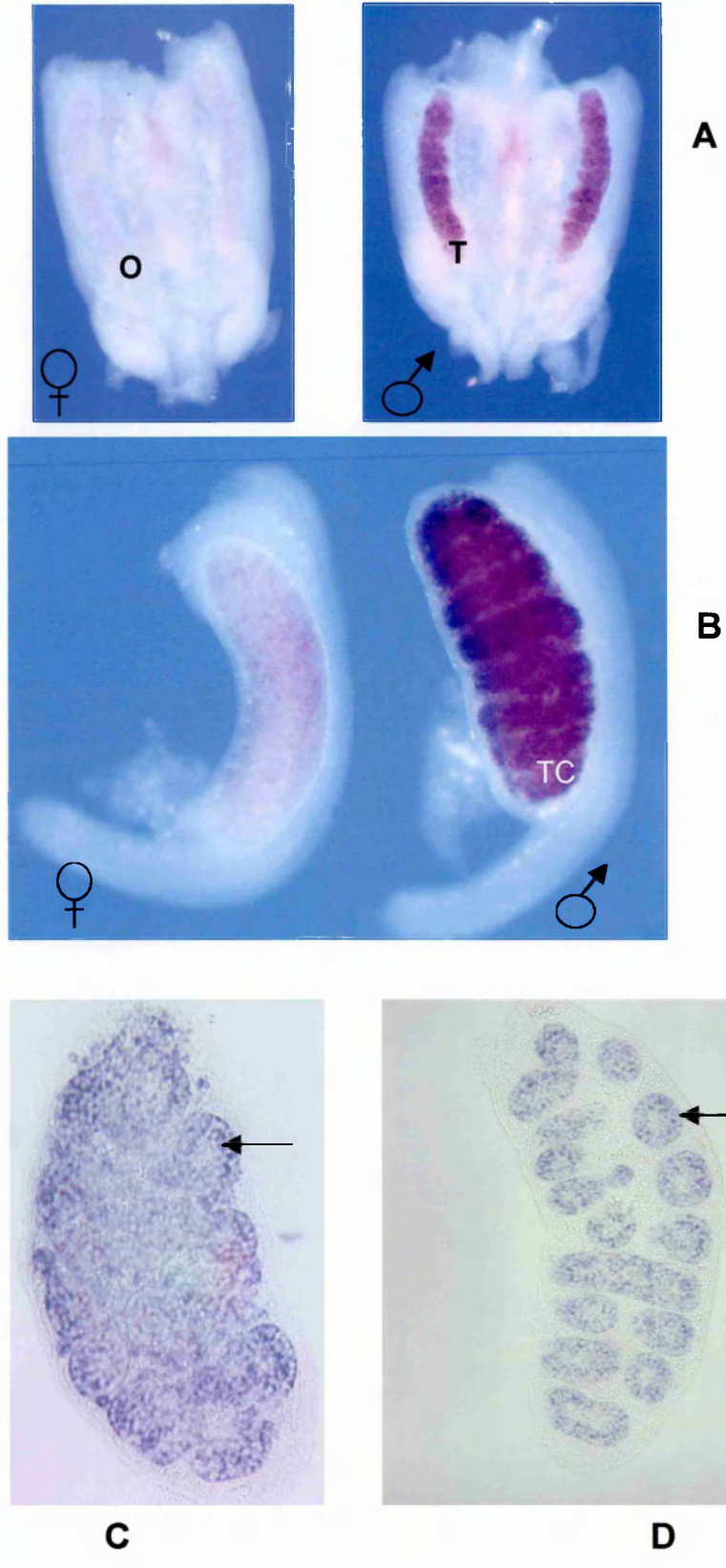

Figure 3.1

Figure 3. 1 *Adh4* is expressed in the developing male gonad

Representative images of wholemount *in situ* hybridisation (WMISH) of gonad explants with an *Adh4* riboprobe are shown. Expression is observed along the length of the testis at 12.5 dpc. Expression in the ovary is negligible in comparison (A). At 13.5 dpc transcripts are primarily confined to the testis cords in the male. Low level expression is still observed along the length of the ovary (B). Longitudinal sections of 13.5 dpc males revealed expression concentrated towards the periphery of the testis cord (arrows C) in a similar fashion to *Sox 9* expression (D).
O ovary, T testis, TC testis cords.

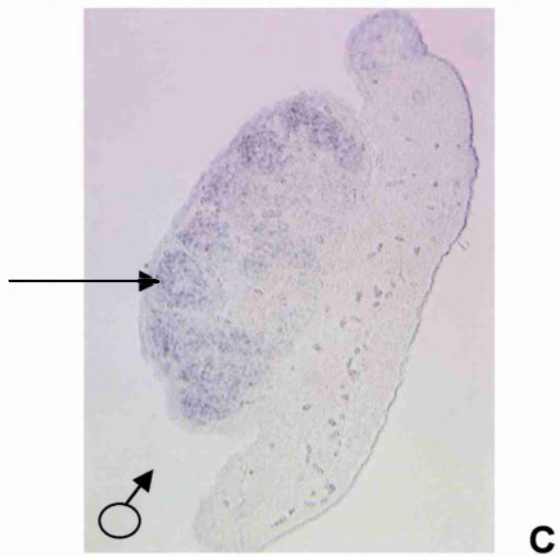
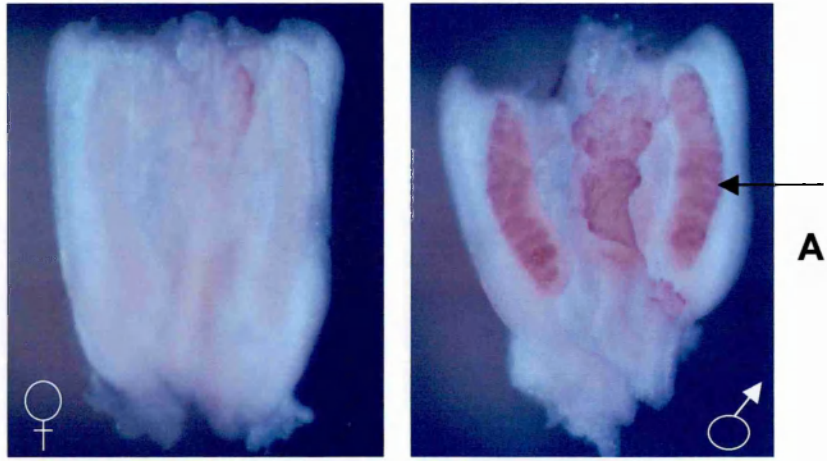

Figure 3.2

Figure 3.2 *Mod-1* shows male-enhanced expression in the developing gonad

Representative images of WMISH of gonad explants with a *Mod-1* riboprobe are shown. *Mod-1* expression is enhanced in the developing testis cords at 12.5 dpc (A arrow). Expression is seen in the testis cords at 13.5 dpc (B). Low level expression is seen in the ovary at both stages. Low levels of expression are also observed in the Müllerian duct mesenchyme of both sexes at 13.5 dpc. Sagittal sections of 13.5 dpc male gonads (C); revealed expression concentrated towards the periphery of the cord (arrows) in a similar fashion to *Sox9* expression.

M, Müllerian duct mesenchyme, TC, testis cords.

3.4.5 Cerebellin 1 precursor protein (*Cbln1*) is expressed in the interstitium of male gonads at 13.5 dpc

Precerebellin 1 (*Cbln1*) is the precursor of cerebellin, a brain-specific neuropeptide. In addition to neuropeptide properties, *Cbln1* also has structural features similar to circulating atypical collagens, and it forms heterodimeric complexes with *Cbln3* (Pang et al., 2000).

WMISH of 13.5 dpc male and female gonads supported the original sexually dimorphic expression profile observed in the microarray data. However, as with the results of *Hey2*, expression is seen between the testis cords. This was confirmed upon sectioning (Figure 3.4A and B). The cell-type specificity of expression is unclear but it appears to be distinct to that of *Hey2*.

3.4.6 Solute carrier family 20, member 1 (*Slc20a1*) is expressed in the developing testis from 12.5 dpc

Slc20a1 encodes the *Pit1* phosphate transporter (Palmer et al., 2000). At 13.5 dpc WMISH revealed that *Pit1* is expressed in the testis cords of the male gonad. Sectioning also showed expression corresponding to *Sox9*-positive cells. Expression was absent from females (Figure. 3.5).

3.4.7 GATA binding protein 2 (*Gata2*) expression is restricted to the ovary

Gata2 is a member of the GATA family of zinc finger transcription factors. WMISH performed on male and female gonads at 12.5 and 13.5 dpc reveals

expression exclusively in the developing ovary. This confirms the initial findings of the microarray data. Sectioning of the 13.5 dpc explants after hybridization reveals a punctate pattern of expression throughout the ovary (Figure 3.6). A detailed examination of cell-type specificity will be presented in Chapter 4.

3.4.8 Vanin-1 (*Vnn1*) is expressed in the developing male gonad

Vanin-1 encodes a GPI-(glycosylphosphatidylinositol) anchored cell surface molecule, whose putative function has been postulated to be involved in the homing of bone marrow precursor cells to the thymus under physiologic conditions. As expected from the microarray data, expression is prominent in the testis at 13.5 dpc, with no expression seen in the ovary at this stage. This sexual dimorphism is also observed at 12.5 dpc. Sections of the testis revealed a concentration of signal towards the periphery of the testis cords, in a similar fashion to *Sox9* expression. This region corresponds to the Sertoli cells (Figure 3.7).

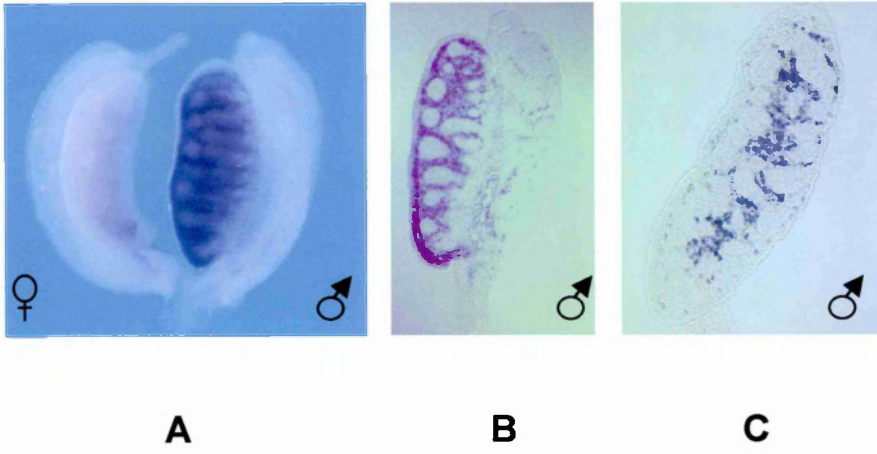

Figure 3.3

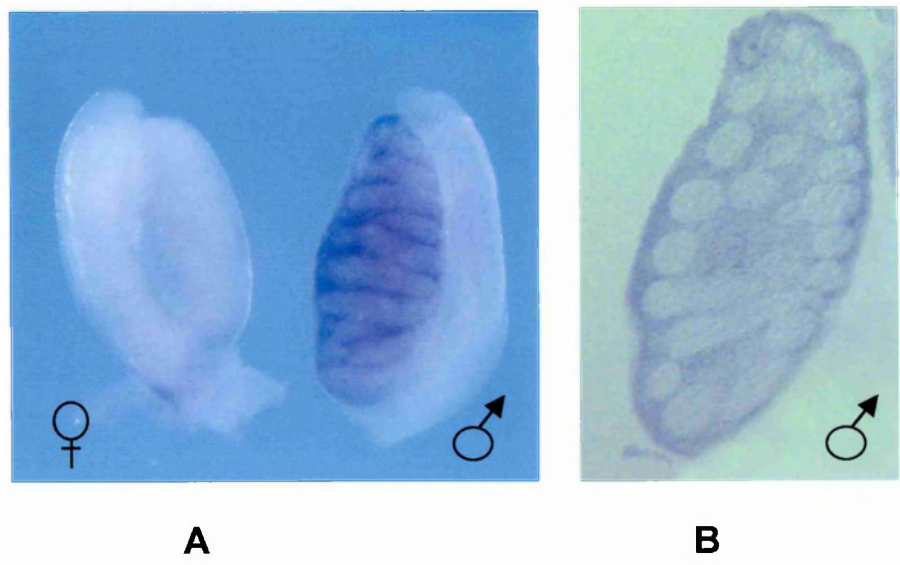

Figure 3.4

Figure 3.3 *Hey2* expression is male-specific in gonads at 13.5 dpc

Representative images of WMISH of gonad explants with a *Hey2* riboprobe are shown. Sexually dimorphic expression can be observed, with expression in the male concentrated in the interstitium. Low levels of expression can be seen in the ovary (A). In cross-section this is confirmed (B). Expression can be seen in the same area of the gonad as the Leydig cell marker *3βhsd* (C), though expression is more extensive in the case of *Hey2*.

Figure 3.4 *Cbln1* is expressed between the testis cords in male gonads at 13.5 dpc

Figure 3.4 shows representative images of WMISH of gonad explants with a *Cbln1* riboprobe. Expression is seen around the testis cords in the male and is absent from the female (A). Longitudinal cross-section reveals widespread expression in the interstitium of the testis (B).

3.4.9 Negative candidate clones

Six additional candidate clones from initial microarray data were also examined. However, WMISH revealed little or no expression, or expression was not confirmed to be sexually dimorphic. The following table summarises the result for each gene, showing accession number and from which library each was located, initial expression data (from microarray results) and WMISH verification results (Table 3.3).

Gene	Accession	Library	Microarray expression	WMISH expression
<i>Cfi</i>	NM_007686	NIA/OLIGO	MALE ENHANCED	NO EXPRESSION
<i>Pcm1</i>	AB029291	NIA/OLIGO	MALE ENHANCED	NO EXPRESSION
<i>Man2b1</i>	NM_010764	NIA/OLIGO	MALE ENHANCED	NO EXPRESSION
<i>Prlr</i>	NM_011164	NIA/OLIGO	MALE ENHANCED	LOW LEVEL
NOVEL	BG072209	NIA/OLIGO	MALE ENHANCED	GERM CELL BOTH SEXES
<i>Ig-Hepta1</i>	NM_007429	NMUR	FEMALE ENHANCED	VERY SLIGHT FEMALE UPREGULATION

Table 3.3 Negative candidate clones

Table 3.3 shows the results of WMISH studies which failed to verify initial microarray data, which initially suggested a sexual dimorphic expression pattern.

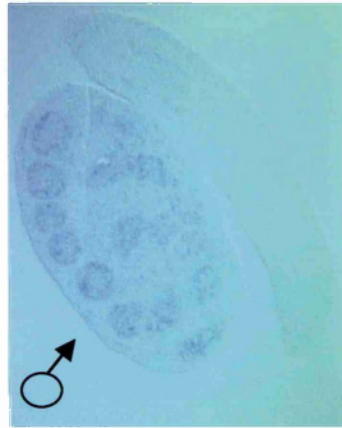
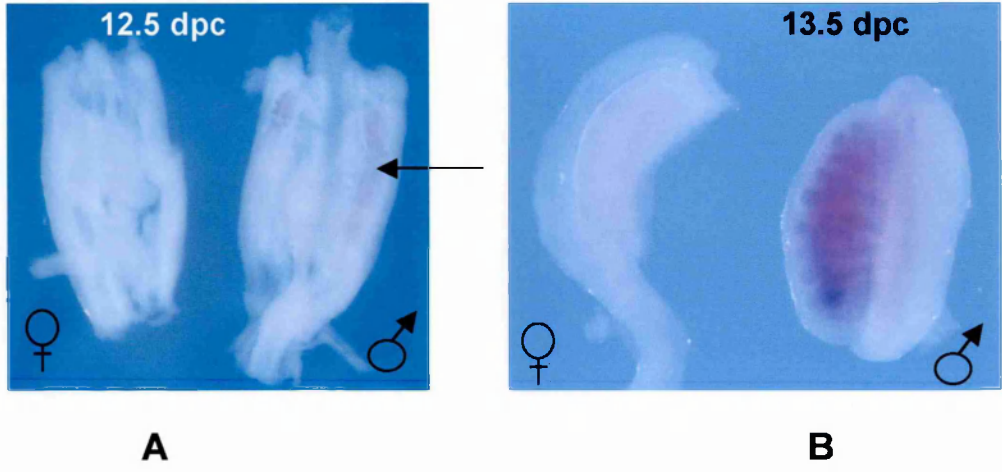

C

Figure 3.5

Figure 3.5 *Pit1* is expressed in the developing testis from 12.5 dpc

Representative images of WMISH of gonad explants with *Pit1* riboprobe are shown. *Pit1* is expressed in the male gonad at 12.5 dpc (Arrow, A). No transcripts are observed in the ovary (A). Expression becomes more intense at 13.5 dpc with transcripts present in the testis cords (B). Longitudinal sections reveal an expression pattern where transcripts are located towards the periphery of the testis cords in a similar pattern to that of *Sox9* (C).

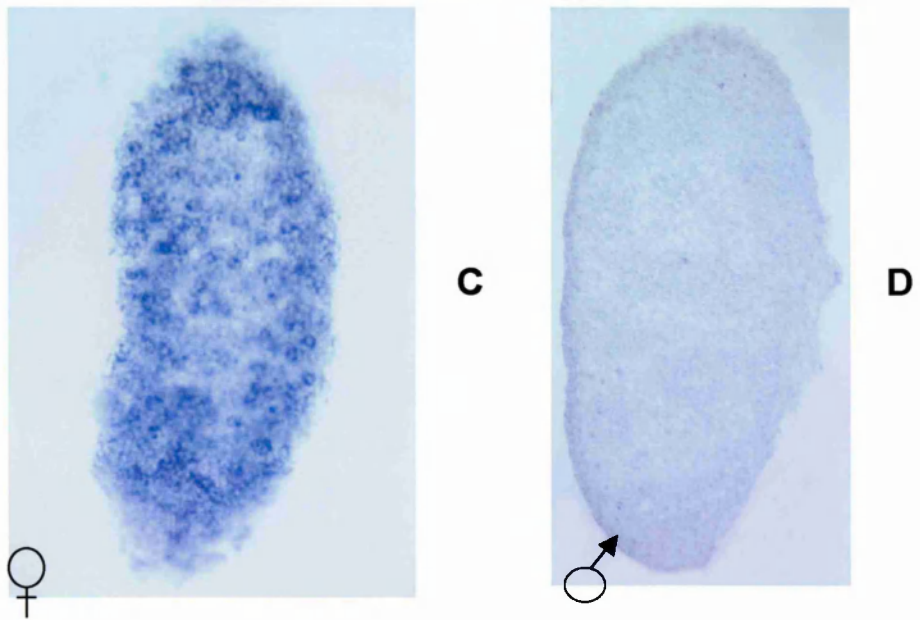
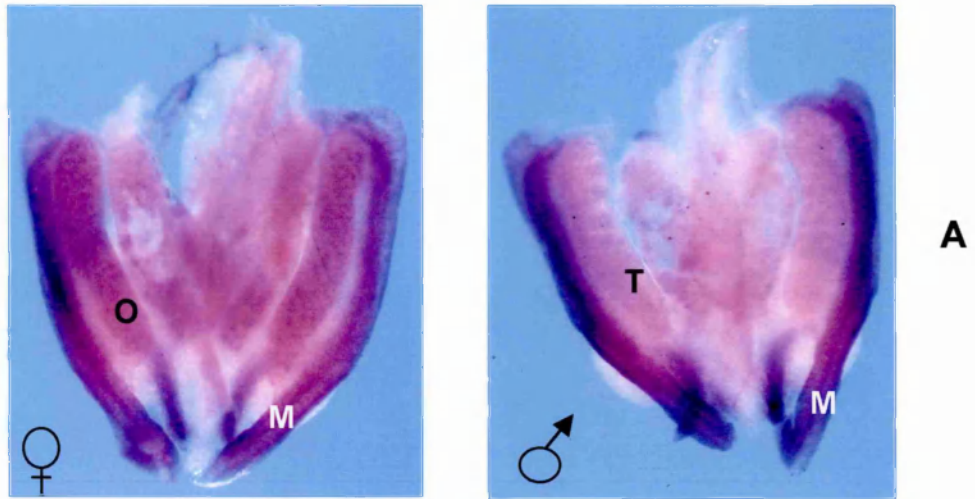

Figure 3.6

Figure 3.6 *Gata2* transcription is restricted to the female gonad

Figure 3.6 shows representative images of WMISH of gonad explants with a *Gata2* riboprobe. At 12.5 dpc *Gata2* is expressed in the ovary and not the testis (A). Expression is seen in the mesonephros in both sexes. This pattern of expression is observed at 13.5 dpc (B). Upon sectioning, expression can be seen to be dispersed throughout the ovary (C) and is absent from the testis (D).

M, mesonephros; T, testis; O, ovary.

3.5 Discussion

Many genes with a role in sexual development have been shown to be transcribed in a sexually dimorphic fashion during gonadogenesis. One way therefore to identify new genes in this process, in either sex, is to screen for additional genes with this property.

Clones which initial microarray data indicated were expressed at higher levels in either the developing male or female gonads were further analysed by WMISH. This technique can not only confirm the sexually dimorphic expression, but can also reveal the site of expression, particularly in the developing testis.

Genes exhibiting enhanced expression in the male gonad

Adh4

Vitamin A (retinol) and provitamin A (beta-carotene) are metabolized to produce specific retinoid derivatives that function in either vision or growth and development. Investigation of retinoid metabolic pathways has resulted in the identification of numerous retinoid dehydrogenases that potentially contribute to metabolism of various retinoid isomers to produce active forms. These enzymes fall into three major families. Dehydrogenases catalyzing the reversible oxidation/reduction of retinol and retinal are members of either the alcohol dehydrogenase (ADH) or short-chain dehydrogenase/reductase (SDR) enzyme families, whereas dehydrogenases

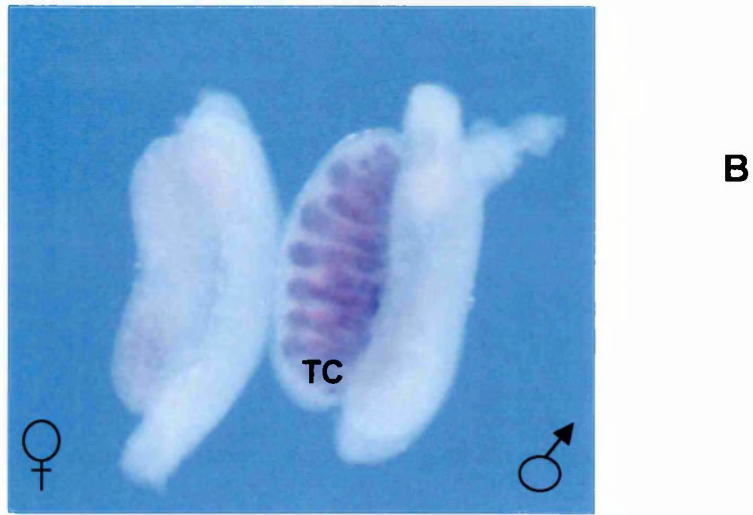
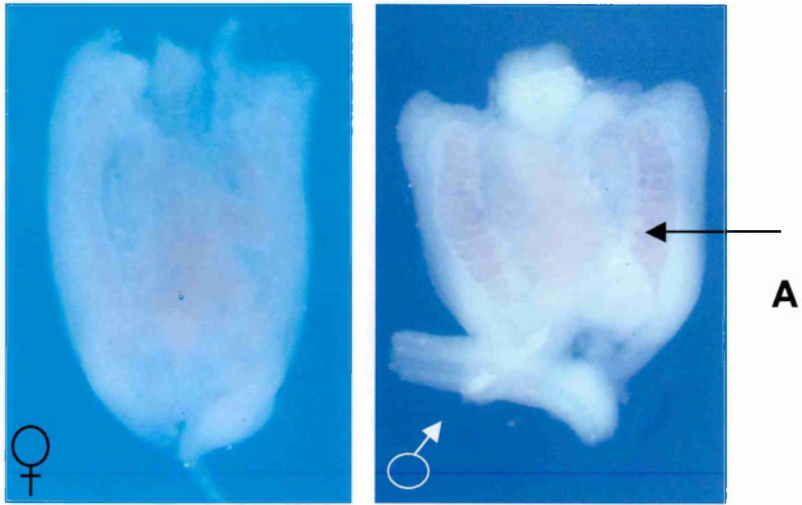

Figure 3.7

Figure 3.7 *Vanin-1* is expressed in the testis of the developing male gonad

Representative images of WMISH of gonad explants with a *Vanin-1* riboprobe are shown. *Vanin-1* is expressed in the male gonad at 12.5 dpc (arrow) and is absent from the ovary (A). Expression is located in the testis cords at 13.5 dpc (B). Expression is observed in a similar pattern to that of *Sox9* when sectioned longitudinally with transcripts located at the periphery of the cord (arrow C). Expression is absent from the ovary at all stages examined.

TC, testis cords.

catalyzing the oxidation of retinal to retinoic acid are members of the aldehyde dehydrogenase (ALDH) family (Duester, 2000).

Retinol is known to play an essential role in spermatogenesis and maintenance of the reproductive tract by its active form (retinoic acid) acting as a ligand for nuclear retinoic acid receptors. *Adh4* catalyses retinol oxidation, the rate-limiting step in the conversion of retinol to retinoic acid, and is expressed in adult mouse testis and epididymis (Deltour et al., 1997).

Previously, transgenic mice have been used to examine the expression of class *Adh4* *in vivo* (Deltour et al., 1997). Expression was highly localized in the brain and craniofacial region at stages during neurulation, corresponding to the otic vesicles and migrating neural crest cells. This indicates that *Adh4* may function in retinoic acid synthesis required for brain and neural crest development, and that it participates in the mechanism of ethanol-induced brain and craniofacial birth defects.

Adh4 exhibits sexually dimorphic expression during gonadogenesis. It is restricted to the region containing Sertoli cells in the testis cords and it encodes an enzyme primarily involved in the metabolism of retinoic acid. This molecule has importance in the maintenance of the adult reproductive tract, and in the development of other embryonic organs, namely the brain and neural crest. However, it was not chosen for further study because we learnt that another research group was examining its possible role in gonad development.

Mod1

Development of the testis is associated with increased cellular activity, requiring a corresponding increase in metabolic energy. Mod1 is a metabolic enzyme, which, although fulfilling the criteria for this screen, was not chosen for further study because its up-regulation in the testis probably corresponds to this metabolic requirement, and may not reflect a direct role in regulating testis differentiation.

Hey2 and Cbln1

Both these genes exhibited male enhanced expression. However, WMISH revealed this expression to be restricted to the interstitium of the developing male gonad. Therefore, they did not meet the criteria for this screen and were not studied further.

Slc20a1

Slc20a1 encodes the Pit1 phosphate transporter, which belongs to the type III sodium-dependent phosphate transporter/retrovirus receptor family. Type III transporters are expressed in a wide variety of tissues and play a role in phosphate uptake in many cell types. Pit1 is also probably involved in regulated phosphate handling in bone forming cells (Palmer et al., 2000).

Slc20a1 is expressed in the Sertoli cells of the developing testis whereas transcripts are absent from the developing ovary. However, it was not chosen to be studied further due to time and resource constraints.

Vanin-1

During development haematopoietic precursor (pro-T) cells migrate to the thymus where they differentiate into mature T lymphocytes. Vanin-1 (vascular noninflammatory molecule 1) is a GPI-anchored cell surface molecule thought to be involved in this thymic homing of bone marrow cells to the thymus. It is expressed by perivascular thymic stromal cells, and antibodies against Vanin-1 were able to block thymus colonization by these precursor cells in both short- and long- term assays. This antibody also blocks lymphostromal cell adhesion, and Vanin-1 is thought to regulate late adhesion steps of thymus homing under noninflammatory conditions (Aurrand-Lions et al., 1996).

Vanin-1 has been shown in this screen to be prominently expressed in the Sertoli cells in the developing testis. Various studies have shown that the development of the characteristic architecture of the testis is dependent on the male-specific migration of precursor cells from the mesonephros into the gonad (Albrecht et al., 2000; Capel et al., 1999; Martineau et al., 1997; Tilmann and Capel, 1999a; Yao et al., 2003). Given its role in the migration of bone marrow progenitor cells and the importance of cell migration in gonad development, Vanin-1 was chosen to be studied further.

Gata2- a gene up-regulated in the developing ovary

Gata2 is a member of the GATA family of zinc finger transcription factors. This family has been implicated in a wide variety of developmental

processes (Simon, 1995). *Gata2* is known to be essential for the development of primitive haematopoietic cells. Mouse embryos homozygous for a *Gata2* null allele display marked anaemia and die by 11.5 dpc (Tsai et al., 1994). Partial rescue of this mutation reveals a distinct role for *Gata2* in urogenital ridge development. Neonates die from hydroureteronephrosis, with malformed kidneys and ureters (Zhou et al., 1998). There are also malformations in Müllerian and Wolffian duct derivatives, though embryonic testes appear normal at 13.5 dpc.

In contrast to the testis, few ovarian determining genes are known, with the exception of *Wnt4* and *Dax1*. Also, in contrast to the testis, germ cells in the female are important for the development of the ovary. They are required for the initial organisation of ovarian cells into follicles and for the maintenance of the follicles. Therefore, the sexually dimorphic expression of genes was used as the sole criterion when selecting genes expressed in the developing ovary: genes expressed solely in the germ cells of the testis would not have been pursued.

As stated previously *Gata2* is required for the development of primitive haematopoietic cells. Partial rescue of the mutant homozygotes reveals a role for *Gata2* in urogenital development. These mutants exhibit malformations of mesonephros derivatives in the male: this phenotype corresponds with the strong expression seen by WMISH. However, no reports have been made

of the expression in the developing ovary, as seen in this screen. Therefore, a more extensive study of its expression in the ovary is relevant.

3.6 Summary

- cDNA clones were obtained for potential candidate genes involved in gonad development based on their sexually dimorphic profile on DNA microarrays. These were further analysed by WMISH; in order to validate these preliminary data, and to examine the spatial pattern of expression during embryogenesis.
- One gene (*Vanin-1*) with male-specific expression was selected for further study on the basis of its potential role in downstream processes in gonad development, and its presence in the Sertoli cell lineage.
- One female specific gene (*Gata2*) was selected for further study on the basis of its sexually dimorphic expression alone.

**Chapter 4: Detailed characterisation of *Gata2*
expression during gonadogenesis**

4.1 Introduction

Members of the Gata family of transcription factors, which contain zinc fingers in their DNA binding domain, have emerged as candidate regulators of gene expression in haematopoietic cells (Tsai et al., 1994). Gata1 is essential for normal primitive and definitive erythropoiesis and is expressed at high levels in erythroid cells, mast cells, and megakaryocytes. Gata3 expression is restricted to T-lymphoid cells and some non-haematopoietic cell-types, including embryonic stem cells.

Gata2 is expressed in haematopoietic progenitors, including early erythroid cells, mast cells, and megakaryocytes, and also in non-haematopoietic embryonic stem cells, and may play a role in regulating genes controlling growth factor responsiveness or the proliferative capacity of early haematopoietic cells (Tsai et al., 1994).

Mouse embryos homozygous for a *Gata2* null allele display marked anaemia and die by 11.5 dpc (Tsai et al., 1994). Partial rescue of this mutation reveals a distinct role for *Gata2* in urogenital development. Neonates die from hydroureteronephrosis, with malformed kidneys and ureters (Zhou et al., 1998). There are also malformations in the Müllerian and Wolffian duct derivatives, although the embryonic testis appears normal at 13.5 dpc.

This gene was chosen for further investigation for two main reasons. Firstly, despite this extensive study of the effects of this mutation on urogenital development, no data concerning ovarian morphology of rescued mutants

have been reported. Secondly, the previous chapter showed that *Gata2* is expressed in a sexually dimorphic manner during gonadogenesis, with transcripts restricted to the developing ovary. In contrast to testis development, few genes have been shown to exhibit this female-specific expression pattern during ovarian development. In fact only three genes have been shown to exhibit elevated levels of transcription in the developing ovary: *Dax1* (Swain et al., 1996), *Wnt4* (Vainio et al., 1999), and *Psx2* (Takasaki et al., 2000). Each of these is initially expressed in both XX and XY embryonic gonads.

A detailed study of the expression of *Gata2* in the developing ovary, including determining the cell type(s) expressing this gene would therefore be useful in gaining insight into its possible role in ovarian development. The aim of this chapter therefore is to perform a detailed expression analysis of *Gata2* in ovarian development, and to ascertain the cell-type expressing this gene.

4.2 Objectives

- To analyse the complete spatio-temporal expression of *Gata2* during gonad development.
- To determine the cell-type expressing *Gata2*.

4.3 Strategy

- To determine the onset of *Gata2* expression in the developing gonads and to compare expression between the development of the testis and ovary by WMISH.
- Two strategies can be used in order to determine the cell-type expressing *Gata2* in the ovary. Firstly, *Gata2* expression can be studied in embryos homozygous for the extreme allele of white dominant spotting (W^r/W^r) whose gonads lack primordial germ cells (Buehr et al., 1993b). Secondly, expression of *Gata2* can be compared to the expression of *Oct4*, a marker of germ cells in the gonad (Scholer et al., 1990), by *in situ* hybridisation to sections of embryonic ovary.

4.4 Results

4.4.1 Expression studies of *Gata2*

4.4.1.1 Onset of expression

Expression of *Gata2* was first observed in the developing ovary at 11.5 dpc. Expression was examined earlier, at 10.5 dpc, but at this stage only mesonephric signal was observed. This mesonephric expression was observed in both sexes, though relatively greater expression was observed in the female mesonephros (Figure.4.1A and B). This mesonephric expression illustrated that the *Gata2* riboprobe synthesised was indeed working and therefore served as a useful internal control for the WMISH efficiency. No

expression was observed in the male gonad at this stage or subsequent stages.

4.4.1.2 Expression from 12.0 dpc to 14.5 dpc

The sexual dimorphism of expression is apparent at 12.0-12.5 dpc when *Gata2* expression in the ovary is prominent but absent from the testis. This pattern of expression continues from this stage until 14.5 dpc (Figure 4.2).

4.4.1.3 Expression at 15.5 dpc

Gata2 transcripts are no longer observed at 15.5 dpc in the ovary, though expression in the male and female mesonephroi is observed at all stages (Figure 4.2).

4.4.2 Determination of cell type expressing *Gata2*

To determine the cell type specificity of *Gata2* expression in the ovary, two complementary approaches were taken. Firstly, *Gata2* expression was examined in W^e/W^e homozygous embryos. Secondly, expression was compared directly to that of the PGC marker *Oct4*.

4.4.2.1 *Gata2* expression in W^e/W^e homozygous embryos

Towards the end of gastrulation of the mouse embryo, the germ cells are distributed along the hind gut, from which they migrate into the genital

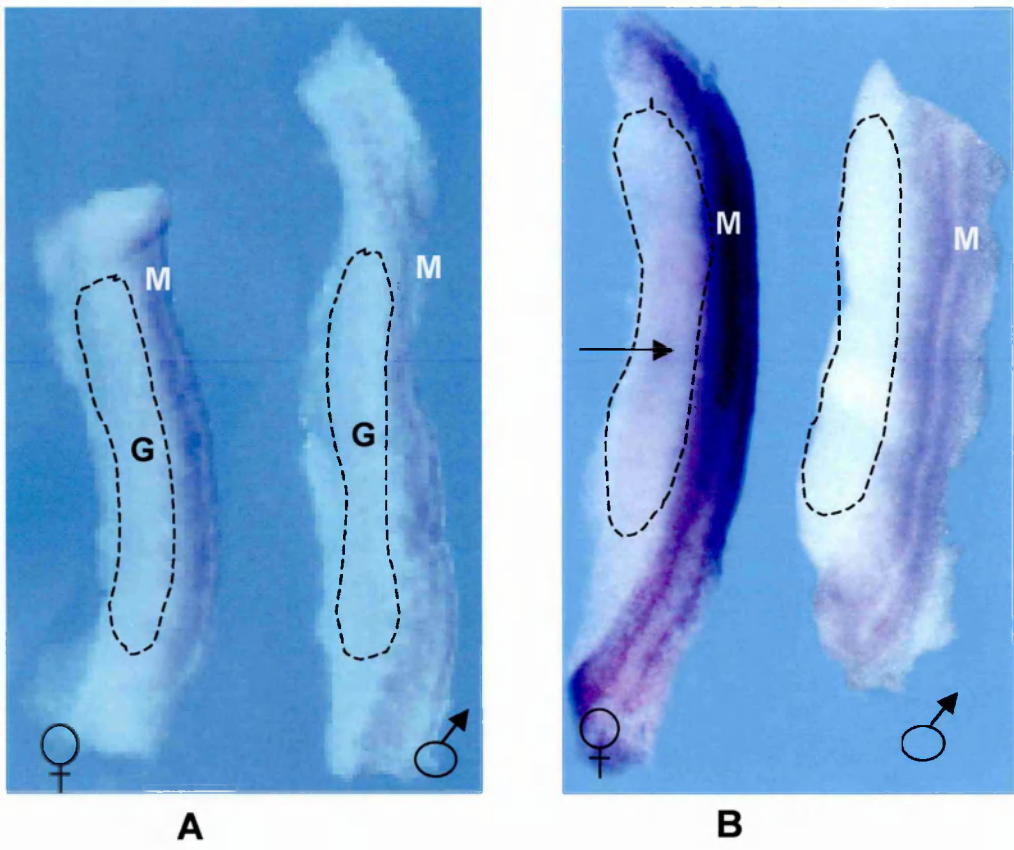

Figure 4.1_

Figure 4.1 *Gata2* is first expressed at 11.5 dpc

WMISH using a *Gata2* riboprobe reveals no expression at 10.5 dpc in the testis or ovary (A). However, transcripts are observed in the mesonephroi in both sexes, though there is a greater intensity of expression in the female. Expression is first observed in the female gonad at 11.5 dpc (arrow), but is absent from the male (B). Expression in the mesonephros again shows a greater intensity in the female compared with the male (B). M, mesonephros; G, gonad (area surrounded by dotted line).

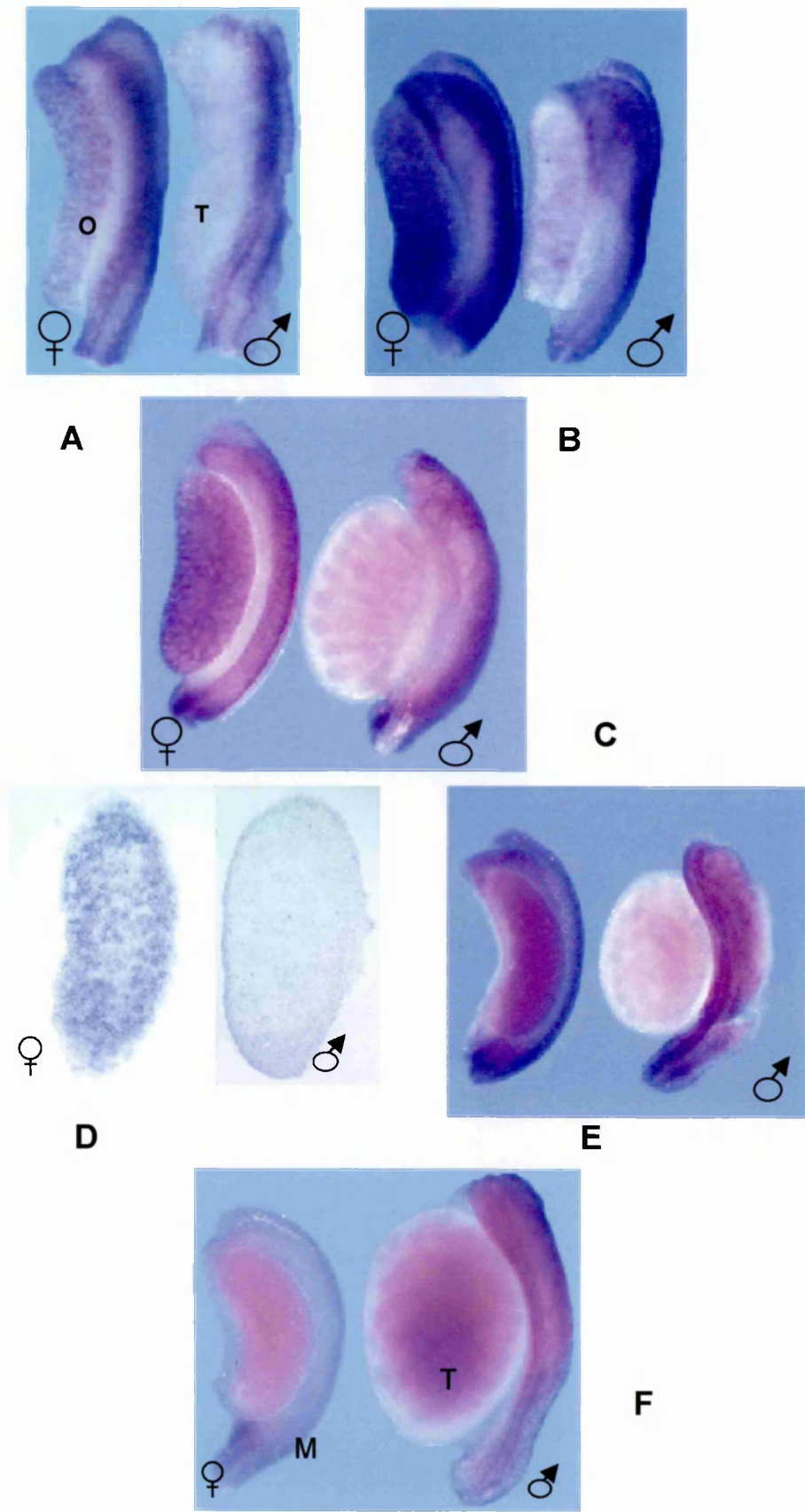

Figure 4.2

Figure 4.2 *Gata 2* exhibits continued sexually dimorphic expression from 12.0 dpc to 14.5 dpc and is absent by 15.5 dpc

High levels of *Gata2* transcript are observed exclusively in the female gonad at 12.0 dpc (A), 12.5 dpc (B), and 13.5 dpc (C). No expression is seen in the testis at these stages. Longitudinal sections through the 13.5 dpc ovary and testis confirm expression of *Gata2* in the ovary and absence of expression in the testis (D). Expression is still observed in the ovary at 14.5 dpc and is absent from the testis (E). Minimal expression can be seen in the ovary and female mesonephros at 15.5 dpc. Diffuse staining can be seen in the testis at 15.5 dpc, however sectioning confirmed this as probe trapping (data not shown). Probe trapping occurs when WMISH is performed on larger hollow tissues. Subsequent washing after probe treatment is insufficient to remove any probe trapped in internal structures, in this case the testis cords at 15.5 dpc (F).

T, testis; M, mesonephros; O, ovary.

ridge. Throughout this period they rely on the c-kit/stem cell factor signal transduction pathway for their continued proliferation. Therefore, embryos homozygous for mutations in genes coding for either the receptor (*W*) or the ligand (*Steel*) are deficient in germ cells.

Germ cell migration studies in embryos homozygous for the extreme allele of dominant white spotting (*W^e*) (Buehr, 1993) found that germ cells did survive after 8.5 dpc, but their numbers did not increase and migration was defective. Very few germ cells reach the genital ridge. Ovaries were therefore collected from 13.5 dpc embryos homozygous for the extreme allele (*W^e*) of *c-kit*. Expression was then examined to see if ovarian *Gata2* is dependent on the presence of germ cells.

Homozygous mutants and wild-type littermates were identified by genotyping using Southern blotting and *Gata2* expression was analysed by WMISH. Figure 4.3 shows that *Gata2* transcripts are present in the wild-type ovary and mesonephros. They are also present in the *W^e/W^e* mesonephros, but, expression is absent in the *W^e/W^e* ovary. These data demonstrate that ovarian expression of *Gata2* is dependent on the presence of germ cells.

4.4.2.2 *Gata2* expression is limited to the germ cell lineage of the ovary

In order to distinguish between germ cell induced somatic expression of *Gata2* and germ cell restricted expression, a comparative *in situ* hybridisation analysis was performed on sections with the germ cell marker *Oct4*

1. The first part of the document is a letter from the author to the editor.

2. The second part is a letter from the editor to the author.

3. The third part is a letter from the author to the editor.

4. The fourth part is a letter from the editor to the author.

5. The fifth part is a letter from the author to the editor.

6. The sixth part is a letter from the editor to the author.

7. The seventh part is a letter from the author to the editor.

8. The eighth part is a letter from the editor to the author.

9. The ninth part is a letter from the author to the editor.

10. The tenth part is a letter from the editor to the author.

11. The eleventh part is a letter from the author to the editor.

12. The twelfth part is a letter from the editor to the author.

13. The thirteenth part is a letter from the author to the editor.

14. The fourteenth part is a letter from the editor to the author.

15. The fifteenth part is a letter from the author to the editor.

16. The sixteenth part is a letter from the editor to the author.

17. The seventeenth part is a letter from the author to the editor.

18. The eighteenth part is a letter from the editor to the author.

19. The nineteenth part is a letter from the author to the editor.

20. The twentieth part is a letter from the editor to the author.

21. The twenty-first part is a letter from the author to the editor.

22. The twenty-second part is a letter from the editor to the author.

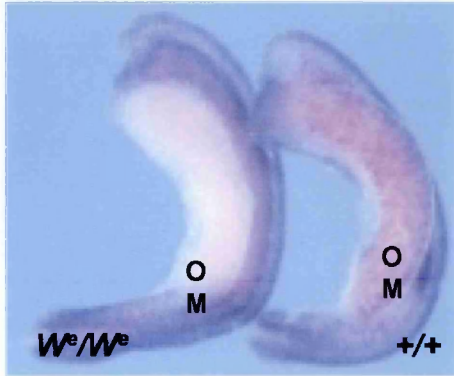

A

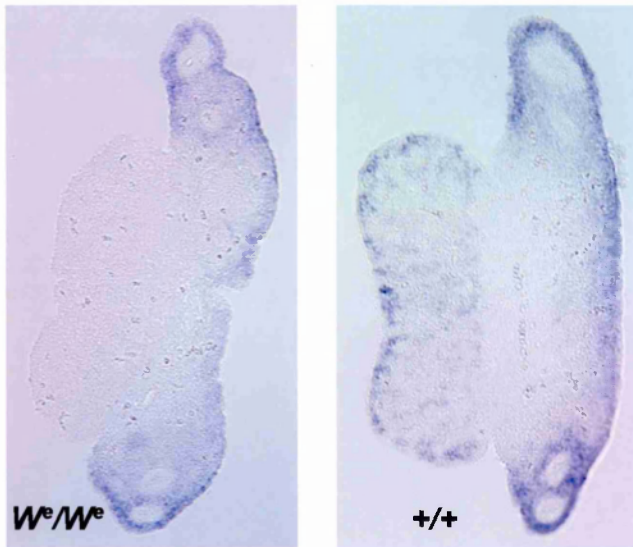

B

Figure 4.3

Figure 4.3 Ovaries from embryos homozygous for the W^e allele do not express *Gata2*

WMISH on gonads at 13.5dpc using a *Gata2* riboprobe reveals *Gata2* expression in the developing ovary and mesonephros of wild-type littermates, and in the mesonephros of mutants (A). However it is not expressed in the mutant ovary. Longitudinal sections confirm these WMISH data (B).

O, ovary; M, mesonephros.

(Scholer et al., 1990). Ovaries were examined at 13.5 dpc since this represents the latest stage at which both *Oct4* and *Gata2* display high levels of expression (Nichols et al., 1998).

Gata2 expression is visible in the ovary and mesonephric mesenchyme (Figure 4.4A), whilst *Oct4* is restricted to the germ cells of the ovary (Figure 4.54B).

Simultaneous hybridisation of differentially labelled *Oct4* and *Gata2* probes to the same sections indicates that ovarian expression of *Gata2* overlaps that of *Oct4* as evidenced by a mix of the blue and red probes revealing a purple signal (Figure 4.4C).

In the mesonephric mesenchyme the signal is blue due to expression of *Gata2* but absence of *Oct4*. These data strongly suggests that *Gata2* transcripts are restricted to the germ cell lineage at this stage.

4.4.3 *Gata2* expression in XO embryonic gonads

In female embryos, all epiblast-derived cell lineages, including the germ cell lineage, initially show random X- inactivation (McMahon, 1981). Therefore, as germ cells are migrating towards the genital ridge, dosage compensation for X-linked genes is achieved. When germ cells enter the genital ridge, their silent X chromosome becomes reactivated (Monk, 1981). Therefore, both X chromosomes are expressed throughout oogenesis. It is noticeable that the

Gata2 expression profile described here coincides with the timing of this reactivation of the silent X chromosome in females.

To address this possible association, expression of *Gata2* was examined in 13.5 dpc female gonads which do not undergo X inactivation, due to the presence of only one X chromosome (XO) and hence no reactivation of the silent X occurs. In order to identify XO embryos we used a colony of mice segregating for the Cream (*Crm*) mutation. Adult X^{Crm}/O females were distinguished from heterozygous carriers ($X^{Crm}/+$) by their variegated fluorescence under UV light. Once identified, XO females were crossed with C3H/HeH males. XO embryos were then identified by an absence of both a Barr body and a PCR product when assayed for the Y chromosome-linked gene *Ube1y*. Using this cross XO embryos were generated at a greater frequency than in normal wild-type crosses with 50% of females carrying only one X chromosome.

A down-regulation of *Gata2* transcription in these mice might suggest a direct role for *Gata2* in the reactivation process. However, *Gata2* transcription is unaffected in XO embryonic gonads when compared to XX and XY littermates (Figure 4.5).

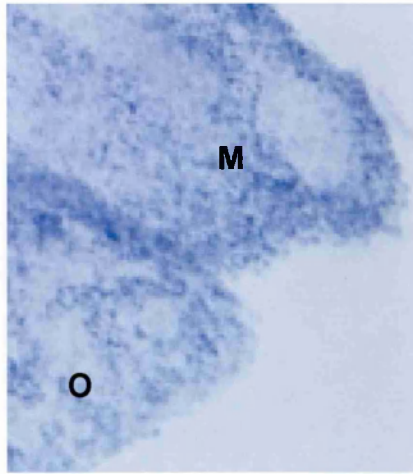

A



B

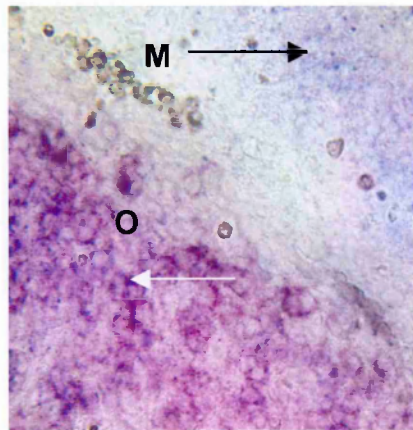

C

Figure 4.4

Figure 4.4 Gata2 expression is restricted to germ cells of the ovary

Figure 4.4 shows representative images of section *in situ* hybridisations using two riboprobes, either *Gata2*, *Oct4* or a combination of both on female gonads at 13.5 dpc. *Gata2* expression (blue) is observed in a subset of cells in the ovary and mesonephros (A). The primordial germ cell marker *Oct 4* (red) is restricted to the germ cells in the ovary (B). *In situ* hybridisation using both *Oct 4* and *Gata2* probes simultaneously reveals co-expression (purple signal) (C) in all ovarian cells exhibiting expression (for example the cell indicated by the white arrow), demonstrating that *Gata 2* is expressed in germ cells. In the mesonephric mesenchyme the signal is blue due to expression of *Gata2* but absence of *Oct 4* (black arrow) (C).
O, ovary; M, mesonephros.

4.5 Discussion

Gata2 was shown to exhibit a sexually dimorphic expression pattern in initial microarray experiments, with transcripts detected at higher levels in the female gonad. Because of the rarity of known genes which show this expression pattern, this gene was studied further.

The ovarian expression of *Gata2* was confirmed and the onset of expression found to be at 11.5 dpc. No testicular expression was observed at any stage; however, expression was seen in the mesonephric mesenchyme of both sexes. Expression in the ovary was eventually down-regulated at 15.5 dpc.

In contrast to the testis, the ovary exhibits a less well defined gross structure as it develops and at the stages examined it is difficult to deduce the cell type(s) containing *Gata2* transcripts. Ovigerous cords develop between 12.5 and 13.5 dpc (Odor and Blandau, 1969), (Konishi et al., 1986). These cords are not defined by basal laminae as are seen in testicular development, and are not observable at the level of the dissecting light microscope. One cell-type present in the ovary at this stage is the primordial germ cell, and to determine if *Gata2* is expressed here, expression was examined in embryonic gonads lacking germ cells. *Gata2* was found not to be expressed in these gonads.

However, germ cells may be required to induce *Gata2* expression in other (somatic) cell-types. Using *Gata2* in conjunction with *Oct4*, a marker of germ

cells, it was shown that these two transcripts were present in the same ovarian cells.

Only 3 genes to date have been shown to exhibit an ovary-specific pattern of expression in the developing embryo: *Dax1*, *Wnt4*, and *Psx2*. All of these are initially expressed in both sexes and down-regulated in the developing testis. *Stra8* has been reported to be expressed in this manner (Oulad-Abdelghani et al., 1996) but also expressed specifically in the female (Menke et al., 2003). However, *Stra8* expression was observed later in development than *Gata2*, from 12.5 dpc to 14.5 dpc. *Gata2* still shows the earliest expression of a female-specific gene.

This *Gata2* expression, from 11.5 dpc to 14.5 dpc, could point to a role for *Gata2* in the reactivation of the silent X chromosome in the germ cells of the developing ovary. A down-regulation of expression in XO ovaries might further support a direct role for *Gata2* in this process, as cells containing only one X chromosome do not undergo X inactivation or reactivation. However, *Gata2* expression is unaffected in these gonads. Nevertheless, this result does not rule out a potential role for *Gata2* in this process.

The role of *Gata2* in the developing ovary remains unclear. Given that the possible function of *Gata2* in the developing haematopoietic system is to regulate genes controlling growth factor responsiveness or the proliferative capacity of early haematopoietic cells, it could function in a similar fashion in the developing ovary.

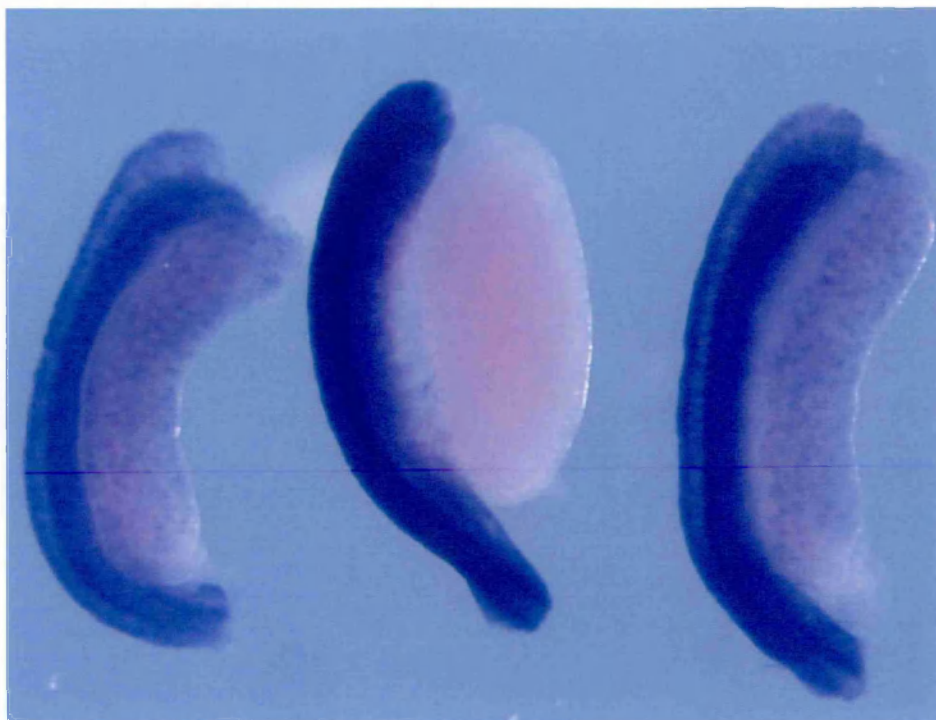

XX



XY

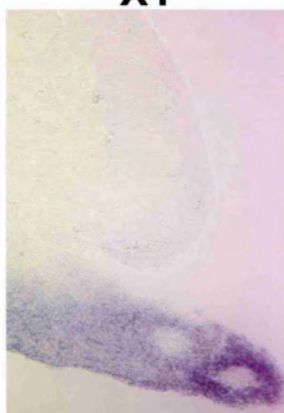

XO

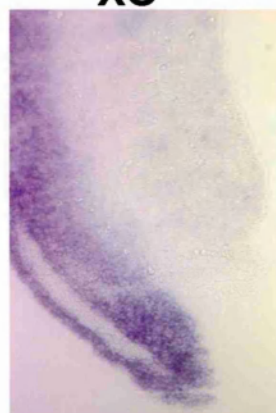

Figure 4.5

Figure 4.5 Gata2 expression in XO embryonic gonads

Gata2 expression is not down-regulated in XO ovaries when compared to XX littermates. Gonadal expression is not observed in male (XY) littermates at 13.5 dpc. Transcripts are seen in the mesonephric mesenchyme in XX, XY and XO gonads. Longitudinal sections confirmed this expression pattern. XO embryos were identified by the absence of a Barr body and by the absence of a PCR product when assayed for the Y chromosome-linked gene *Ube1y*.

Germ cells are known to be important for the construction and/or maintenance of the ovary, and *Gata2* may therefore play a part in this somatic cell regulation. The use of conditional gene targeting, restricting the loss of *Gata2* to the developing ovary, would allow this hypothesis to be tested.

4.6 Summary

- *Gata2* is expressed in the developing ovary between 11.5 dpc and 15.5 dpc, and is absent from the testis.
- Expression is restricted to the germ cell lineage.

**Chapter 5: Detailed characterisation of *Vanin-1*
expression during gonadogenesis**

5.1 Introduction

Vanin-1 was first identified as part of a screen for molecules involved specifically in the homing of bone marrow cells to the thymus (Aurrand-Lions et al., 1996). During fetal development, T cell progenitors are synthesised in the liver and migrate to the thymus. This occurs in several waves at set times during development. After birth this homing of bone marrow cells continues at a low level. These cells must first adhere to the thymic vascular endothelium before entering the thymus, after which they interact with other epithelial cells which support their maturation. Each step in this process depends on interaction with several adhesion molecules. Firstly, cells arrest on contact with endothelial cells. Secondly, there is chemokine induced activation and integrin-dependent reinforcement of cell adhesion. CD31, an endothelial-specific cell marker, contributes to the activation of integrins and participates in the transmigration of cells. These sequential interactions allow the tethering, rolling and activation of pro T cells and their binding to the endothelial cell wall. Therefore, various combinations of adhesion molecules are needed for the homing process to occur. GPI-anchored proteins are also thought to play a role in targeting molecules to the apical membrane. It has been demonstrated in other homing systems that some molecules are required for the specificity of homing, for example, homing to the gut is dependent on the expression by

leukocytes of the $\alpha 4\beta 7$ integrin that binds to the gut endothelial mucin MadCAM-1.

Few molecules have been found to be involved in thymic homing, and to identify more which are expressed by thymic endothelial cells and or perivascular epithelial cells, Aurrand-Lions et al. developed a panel of cell lines representing different subtypes of thymic stromal cells. Monoclonal antibodies recognising membrane molecules expressed by the lines were screened for their ability to stain perivascular cells in immunocytochemical tests on thymic sections and to block cell adhesion *in vitro*. One specific monoclonal antibody, 407, (mAb 407) was shown to block intrathymic homing. This antibody identifies a novel glycosylphosphatidylinositol (GPI)-anchored molecule, Vanin-1. Subsequently, mAb 407 was shown to inhibit thymic regeneration in whole body irradiation tests and to block cell adhesion, though it did not inhibit thymocyte differentiation in organ culture. The molecule recognised by mAb 407 identified a perivascular molecule involved in the regulation of thymic homing under noninflammatory conditions and was therefore named Vanin-1 (vascular noninflammatory molecule-1) (Aurrand-Lions et al., 1996).

Vanin-1 is a GPI anchored 70KDa protein, encoded by a 2.3kb mRNA. This transcript encodes a protein of 55KDa which is subsequently glycosylated. It also exhibits 40% homology to the human biotinidase gene. This gene encodes an enzyme produced by liver cells which catalyses the release of

biotin from its precursor biocytin. However, Aurrand-Lions et al. concluded that it was not the murine equivalent of human biotinidase because of differing sites and cell types of expression and the fact that whereas biotinidase is a secreted molecule, Vanin-1 is not.

Three related human genes, *VNN1*, *VNN2* and *VNN3*, were identified by database homology searches (Galland et al., 1998; Granjeaud et al., 1999). All are located on the long arm of human chromosome 6, a region involved in the invasivity of metastasis in human cancer (Galland et al., 1998). *Vanin-1* is localised on the syntenic region of mouse chromosome 10.

A second mouse gene, *Vanin-3*, was also identified (Granjeaud et al., 1999), though to date no murine equivalent of *Vanin-2* has been identified. Human *VNN1* and murine *Vanin-1* are GPI-anchored, encoding isoforms of pantetheinase ectoenzymes. *VNN2* lacks a leader peptide, whereas both *VNN3* and *Vanin-3* lack this anchoring, and are secreted. However, they both also encode proteins with a pantetheinase activity (Martin et al., 2001). Pantetheinases recycle vitamin B5 to produce cysteamine, a potent antioxidant.

In addition to these, a rat *Vanin-1* orthologue and a putative *Drosophila* homologue were identified (Granjeaud et al., 1999). All human, rat and mouse *Vanin* sequences present a 60% homology at the amino acid level, along with a 40% homology to the Biotinidase sequence.

Vanin-1 is thought to be involved in the homing of bone marrow precursors to the thymus, because a specific antibody to it blocks thymus colonisation after sub lethal irradiation, and also interferes with lymphostromal cell adhesion.

It is believed that Vanin-1, which is expressed in thymic epithelial cells, regulates late adhesion steps of thymic homing under physiologic noninflammatory conditions.

5.2 Aim of this chapter

Chapter three described the sexually dimorphic expression of *Vanin -1* in the gonad at 13.5 dpc. Initial expression studies suggested that expression was located in the Sertoli cells of the developing testis. Therefore, given its role in the migration and homing of pro T cells, it is hypothesised that a similar role might exist for Vanin-1 in the developing testis. The aim of this chapter is therefore to ascertain the precise onset of *Vanin-1* expression in gonad development and to determine the cell-type expressing it. Furthermore, the male-specific expression of Vanin-1 highlights it as a possible candidate for regulation by male-specific transcription factors. Hence, an assay was performed for *Vanin-1* regulatory sequences required for gonadal expression in transgenic embryos.

5.3 Strategy

- To determine the onset of expression of *Vanin-1* in the developing male gonad by WMISH and to determine the cell type expressing *Vanin-1* by examining expression in W^+/W^+ homozygotes (Buehr et al., 1993b) using RT-PCR.
- To identify sequences required for gonadal expression of *Vanin-1* by isolating part of the *Vanin-1* promoter (and upstream genomic regions) and using this to generate a *lacZ* reporter construct. This construct can then be used to generate transgenic mice and *lacZ* expression analysed in the embryonic gonads of these mice. If gonadal expression is observed this genomic fragment would then be further studied in order to isolate the minimal sequences (enhancers) needed for gonad specific *Vanin-1* expression.

5.4 Results

5.4.1 Expression at 10.0-11.5 dpc

A range of embryonic gonad stages were examined in order to determine the onset of *Vanin-1* expression. No expression is observed at 10.5 dpc (data not shown) and 11.0 dpc (Figure 5.1 A) or 11.5 dpc (Figure 5.1B). In each case *Sox9* was used as a positive control for the WMISH.

5.4.2 Onset of expression

Vanin-1 is first observed in the developing male gonad at 12.0-12.25 dpc, immediately prior to overt testis differentiation (Figure 5.2). At no time is expression observed in the developing ovary.

5.4.3 Expression from 12.5 dpc

Vanin-1 continues to be expressed in the developing testis cords at 12.5 dpc and at 13.5 dpc. Longitudinal sections reveal that expression is concentrated around the periphery of the cord in the region of the Sertoli cells and is generally absent from the centre of the cord where the primordial germ cells are located (Figure 5.3 A, B). This sexually dimorphic expression continues through 14.5 dpc and 15.5 dpc, (Figure 5.3 C, D).

5.4.4 Expression of *Vanin-1* is not dependent on the presence of primordial germ cells

Longitudinal sectioning of gonads revealed expression located towards the periphery of the testis cord, in the region of the Sertoli cells. To verify this germ cell-independent expression, the presence of *Vanin-1* transcripts was examined in gonads homozygous for the extreme allele of dominant spotting (W^r/W^r). As described in the previous chapter, these mutants lack primordial germ cells. *Vanin-1* transcripts are present in this mutant, in contrast to those from the germ cell marker *Oct4* (Figure 5.4). These data

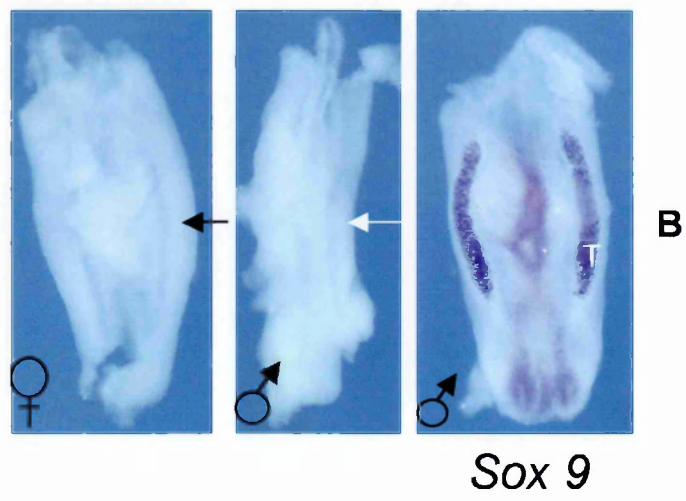

Figure 5.1

Figure 5.1 *Vanin-1* is not expressed between 11.0 and 11.5 dpc

WMISH to detect *Vanin-1* expression was performed on a range of embryonic gonads from 11.0 to 15.5 dpc. The Sertoli cell marker *Sox9* was used as a comparison for expression. No expression of *Vanin-1* is seen at 11.0dpc (arrows) (A), when compared to *Sox9*. Expression was still not detected at 11.5 dpc (arrows) (B).

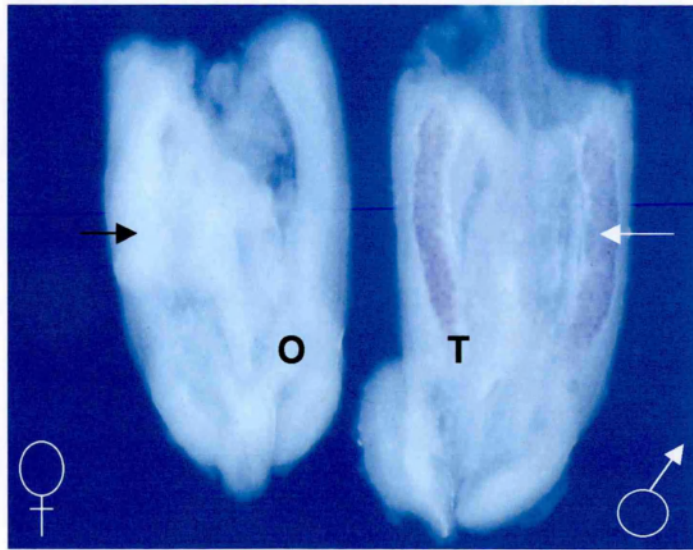

Figure 5.2

Figure 5.2 Onset of *Vanin-1* expression is between 12.0 and 12.25 dpc

Expression of *Vanin-1* is initially observed along the length of the testis (T, white arrow) at 12.0 dpc prior to the formation of testis cords. In contrast, expression is absent from the ovary (O, black arrow).

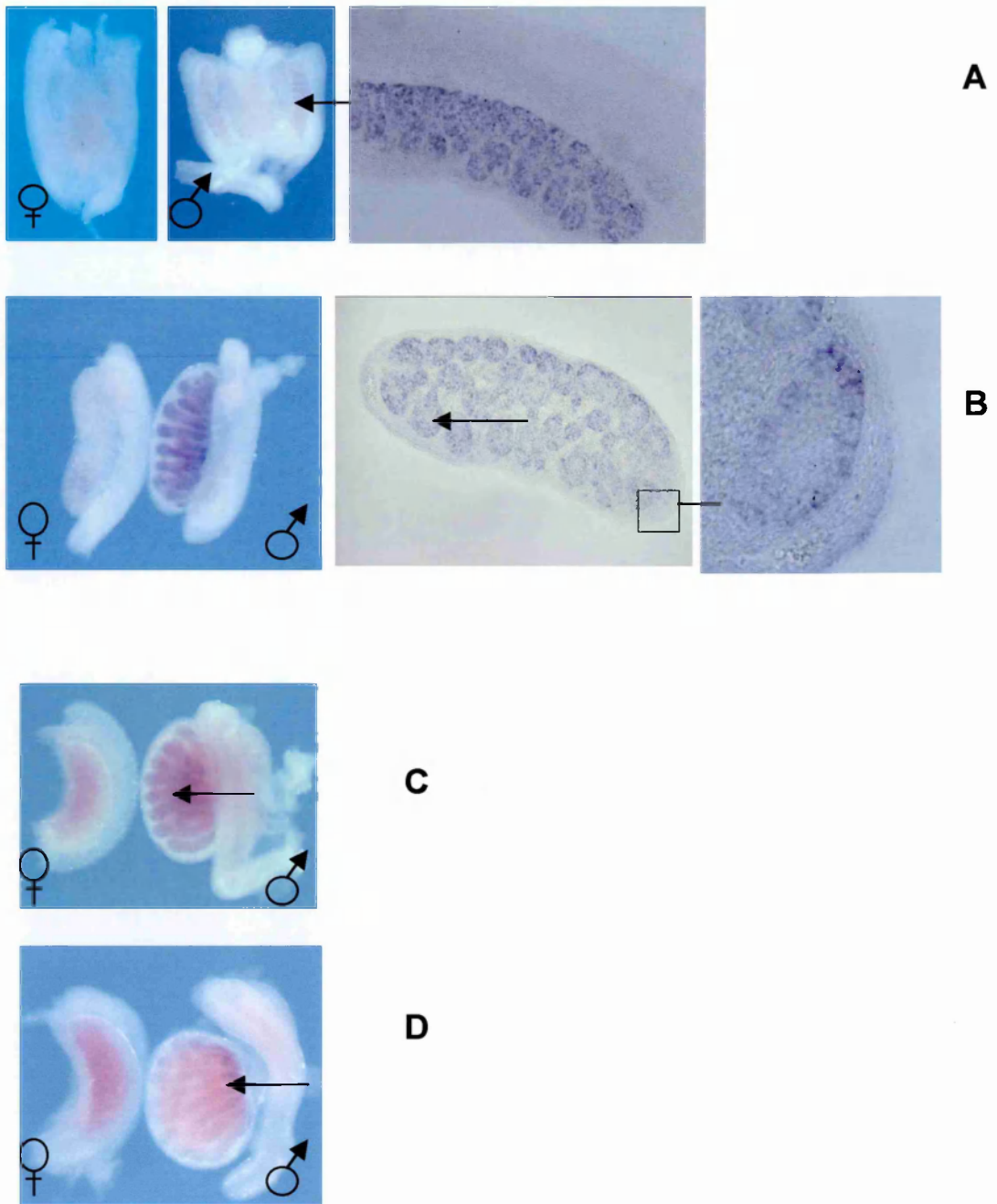

Figure 5.3

Figure 5.3 Expression of *Vanin-1* between 12.5 and 15.5 dpc

Using WMISH *Vanin-1* expression is observed in the developing testis cords (arrow) at 12.5 dpc (A). Expression is observed in the testis cords at 13.5 dpc and is located towards the periphery of the cord (arrow B), this is more clearly visible at higher magnification (Box, B). Continued expression is seen in the testis cords at 14.5 and 15.5 dpc (arrows) (C, D). No expression is observed in the ovary at these stages.

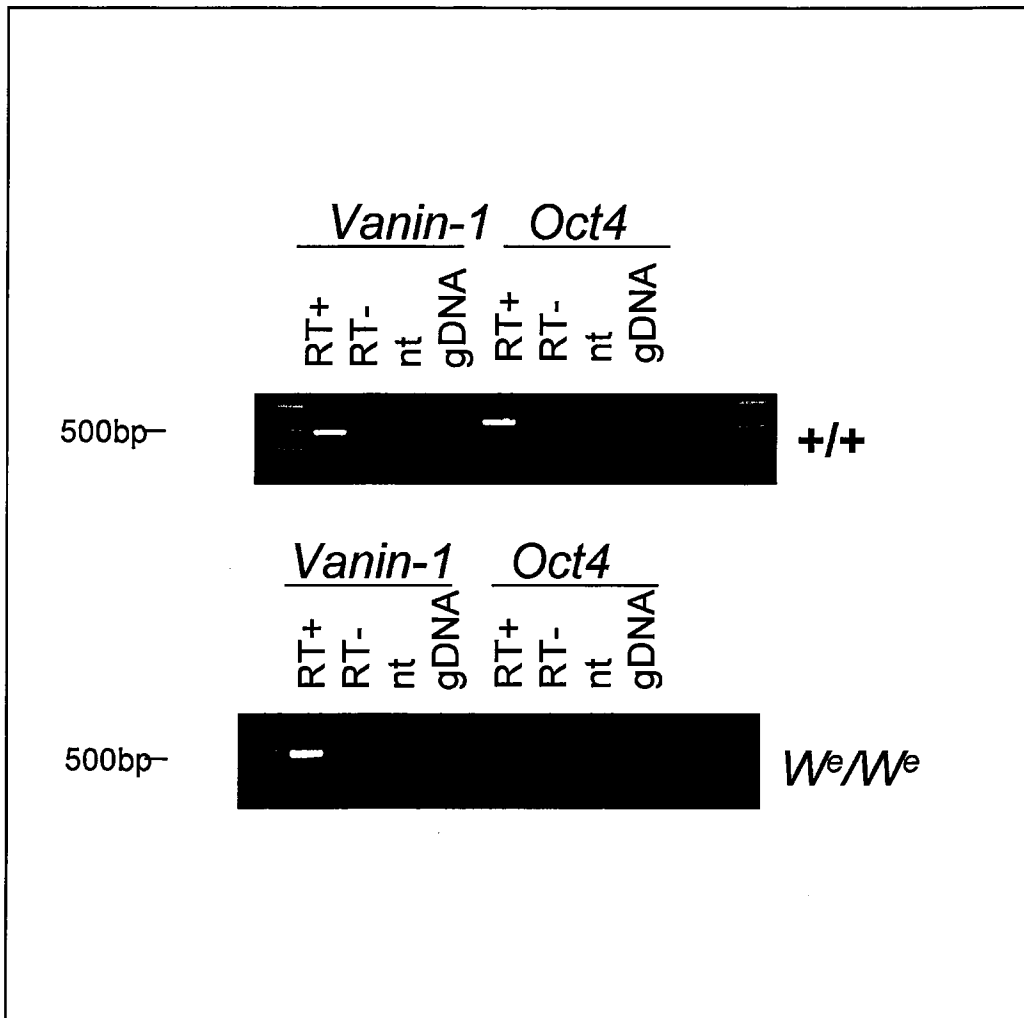

Figure 5.4

Figure 5.4 Expression of *Vanin-1* in gonads from W^e/W^e homozygotes

RT-PCR analysis of *Vanin-1* and the primordial germ cell-specific marker *Oct4* in gonads dissected from wild-type (+/+) 12.5 dpc embryonic gonads give products for each gene (upper gel image). *Oct4* is not expressed in gonads dissected from 12.5 dpc embryos homozygous for the extreme allele of dominant spotting (W^e/W^e) (lower gel image) due to the absence of germ cells. However, these germ-free gonads still express *Vanin-1* indicating that expression in the testis cords at 12.5 dpc is not germ cell-dependent. RT+, PCR template is reverse transcribed gonadal RNA; RT-, template is RNA incubated without reverse transcriptase; nt, no template; gDNA, template is genomic DNA.

support the WMISH results and indicate that *Vanin-1* is expressed in the somatic cells of the testis cords, i.e. the Sertoli cells.

5.5 Isolation and analysis of a *Vanin-1* genomic fragment in transgenic mice

5.5.1 Isolation of a genomic fragment

To isolate sequences which may drive gonadal expression of *Vanin-1* a genomic fragment containing the first exon of *Vanin-1*, along with sequence 5' to it was isolated. A PAC library (available from the HGMP Resource Centre, Hinxton) was screened using a PCR-amplified probe from *Vanin-1* exon 1 labelled with $^{32}\text{P}\alpha\text{-dCTP}$ (see appendix A for primer sequences).

Eight PAC clones were identified as positive for this first exon (data not shown). To isolate fragments of sub-clonable size containing this exon, these PACs were digested with a range of restriction enzymes and again probed with the $^{32}\text{P}\alpha\text{-dCTP}$ -labelled *Vanin-1* first exon. A *SacI* fragment of approximately 6Kb, detected in PAC 38 and PAC 562 was chosen to be studied further because it was large, but not too large to cause difficulties when cloning (Figure 5.5).

This ~6Kb *SacI* fragment was isolated from PAC 562 and cloned into the *SacI* restriction site of the pBluescript plasmid (Stratagene). The inserts from the resulting clones were liberated by digestion with *SacI* and hybridised to a radioactively labelled exon one PCR product to ensure the correct fragment

PAC 38

PAC 437

PAC 562

PAC588

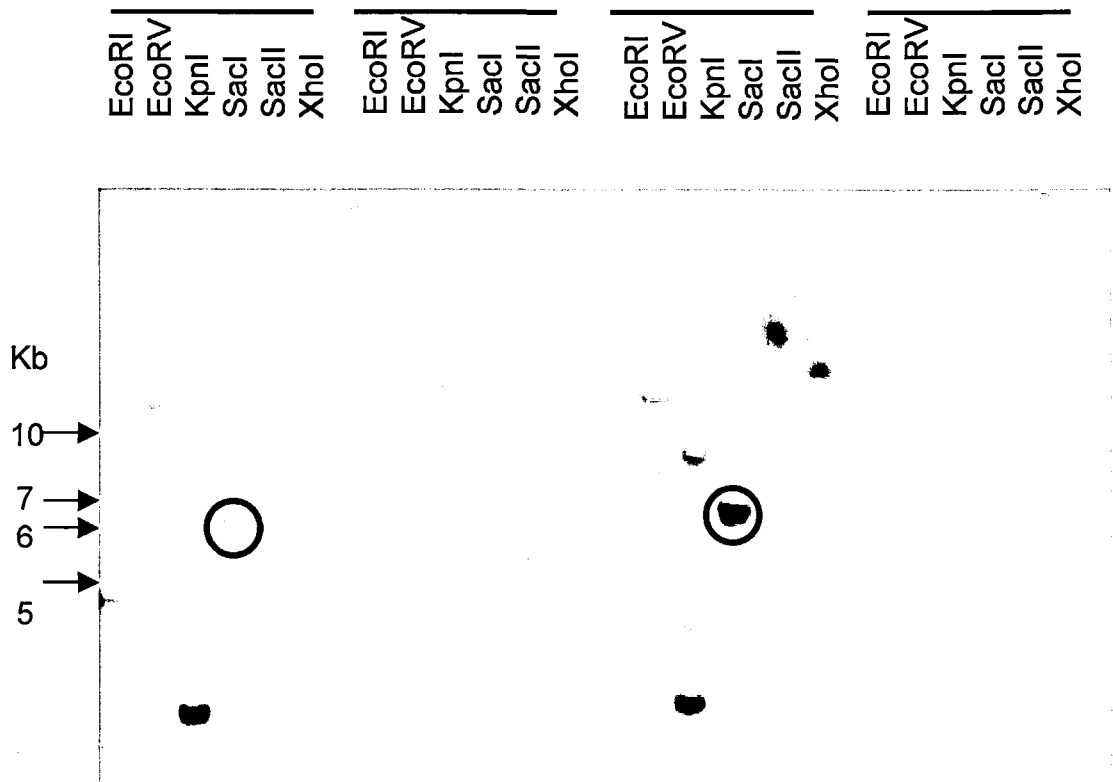
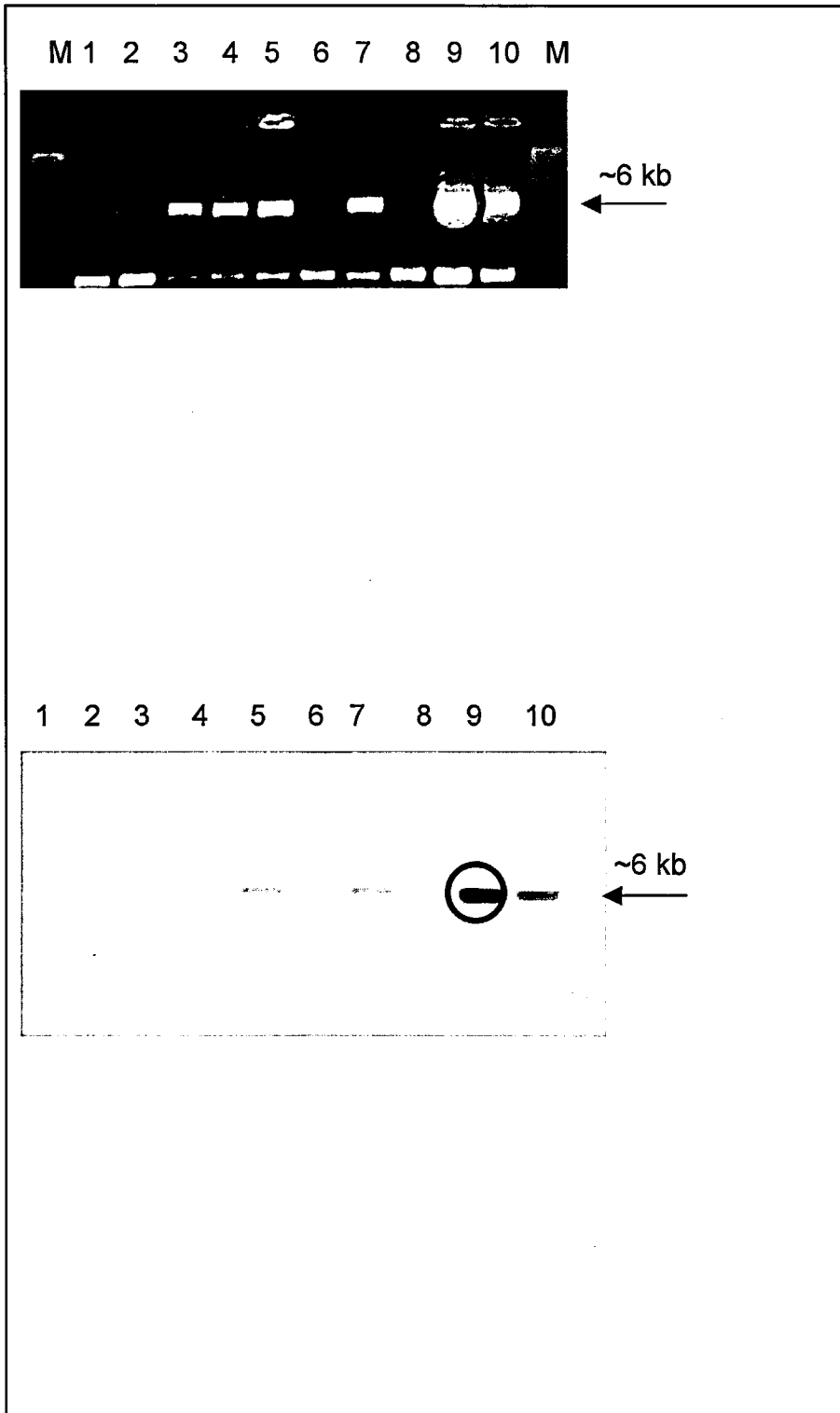

Figure 5.5

Figure 5.5 *Vanin-1* exon one probe detects a 6kb PAC genomic fragment

Figure 5.5 shows an autoradiograph of a PAC Southern blot radioactively probed with *Vanin-1* exon one. This probe detected a *SacI* fragment (blue circle) from 2 PAC clones. This *SacI* fragment was chosen for ease of cloning into pBluescript.



A

B

Figure 5.6

Figure 5.6 6kb fragment cloned into pBluescript and sequenced

The ~6kb PAC fragment was cloned into the plasmid pBluescript. Ten colonies were chosen (Lanes 1-10).

(A) shows an ethidium bromide-stained electrophoresis gel of the 6kb insert liberated from the plasmid when digested with *SacI*. This gel was blotted and probed with the radioactively labeled probe of *Vanin-1* exon one to confirm that this was the correct fragment. One clone (blue circle) was picked for further analysis (B).

had been cloned. Six clones were found to contain the correct insert and one of these was chosen for subsequent study (Figure 5.6).

This clone was sequenced using the vector primers T3 and T7 and also the first exon primers Vnn1F and Vnn1R. These latter primers were used to verify the presence of exon one in this clone. The Ensembl database (Hubbard et al., 2002) was used in order to locate its genomic position which revealed it to be 5' of *Vanin-1*.

The position of exon one within this 6Kb fragment was also determined by PCR using the Vnn1F or the Vnn1R primers together with the vector primers (T7 or T3). A product of ~1.8Kb was obtained with the combination of VnnF1 and T7 and one of ~4Kb when VnnR1 and T3 were used. Hence exon one is positioned towards the 3' end of this fragment, with approximately 4Kb extending upstream of it (5') (Figure 5.7A).

5.5.2 Production of a LacZ reporter construct

The genomic fragment was liberated from pBluescript by *SacI* digestion and cloned into a *SpeI* restriction site of the *LacZ* reporter construct p1229 (a gift from Dr M. Maconochie, MRC Harwell) using blunt ligation (Materials and Methods) (Figure 5.7B). *SacI* could not be used for cloning as this site appears in the *LacZ* coding region of the construct.

The resulting construct was again cut with various restriction enzymes and probed with a ³²P α -dCTP labelled exon one PCR product to confirm the

presence of this exon (Figure 5.8). The orientation of this insert in the vector was also examined by PCR and confirmed to have exon one immediately 5' to the β globin minimal promoter (data not shown).

This construct was then digested with a combination of *XhoI* and *XbaI* to liberate the ~9 Kb fragment containing the 4Kb and exon one ligated to the *LacZ* reporter gene. The construct was purified and then submitted to the Transgenic Facility at MRC Harwell. Four rounds of pronuclear injection were performed to generate transgenic mice.

5.5.3 Transgenic mice

Genomic DNA was isolated from tail biopsies of potentially transgenic founder mice at 3 weeks of age. This DNA was screened for the presence of the *Vnn-1:lacZ* reporter construct by PCR, using primers *lacZN2F/R* (see appendix A) which amplify a 5' region of the *lacZ* gene, to give a 400bp product (Figure 5.9A). PCR using primers to amplify a 3' region to test that the construct had inserted intact was unsuccessful (data not shown).

In addition to this, the integrity of the genomic DNA was tested by PCR using the *Vanin-1* exon one primers in order to test for the presence of endogenous *Vanin-1*. In total 101 potential mice were produced, resulting in the identification of the following four founders (Table 5.1). These four mice were further bred to C57BL/6 wild-type mice, all of which were able to

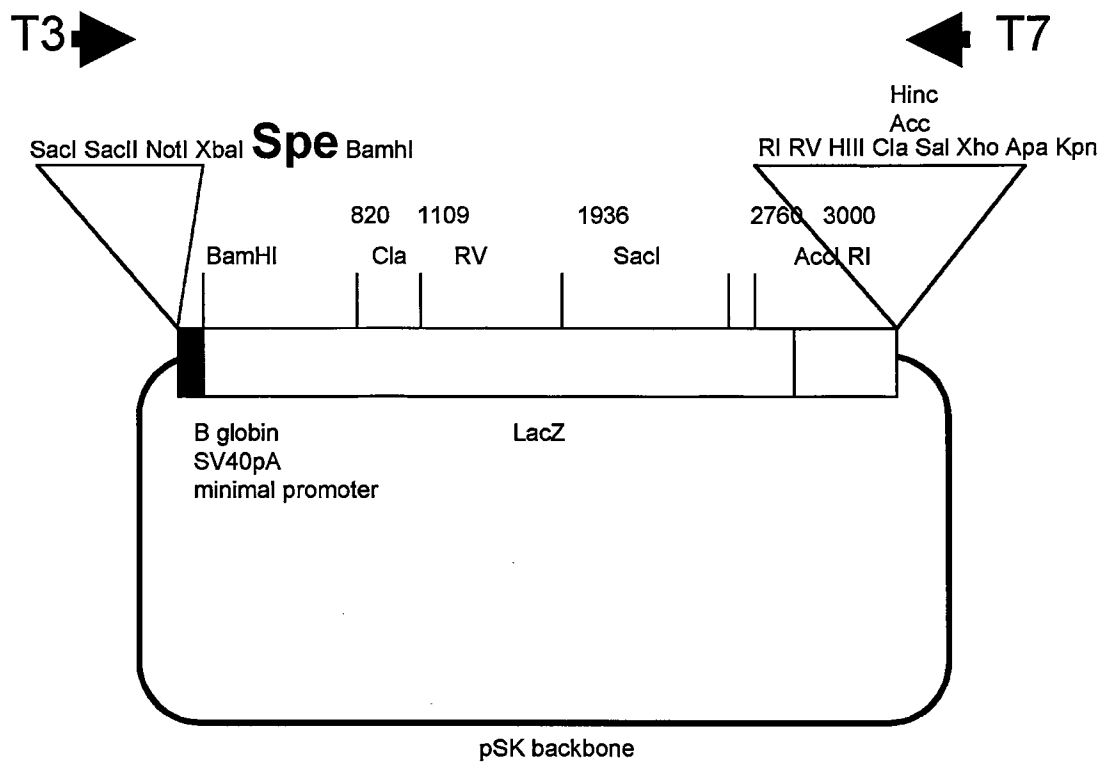
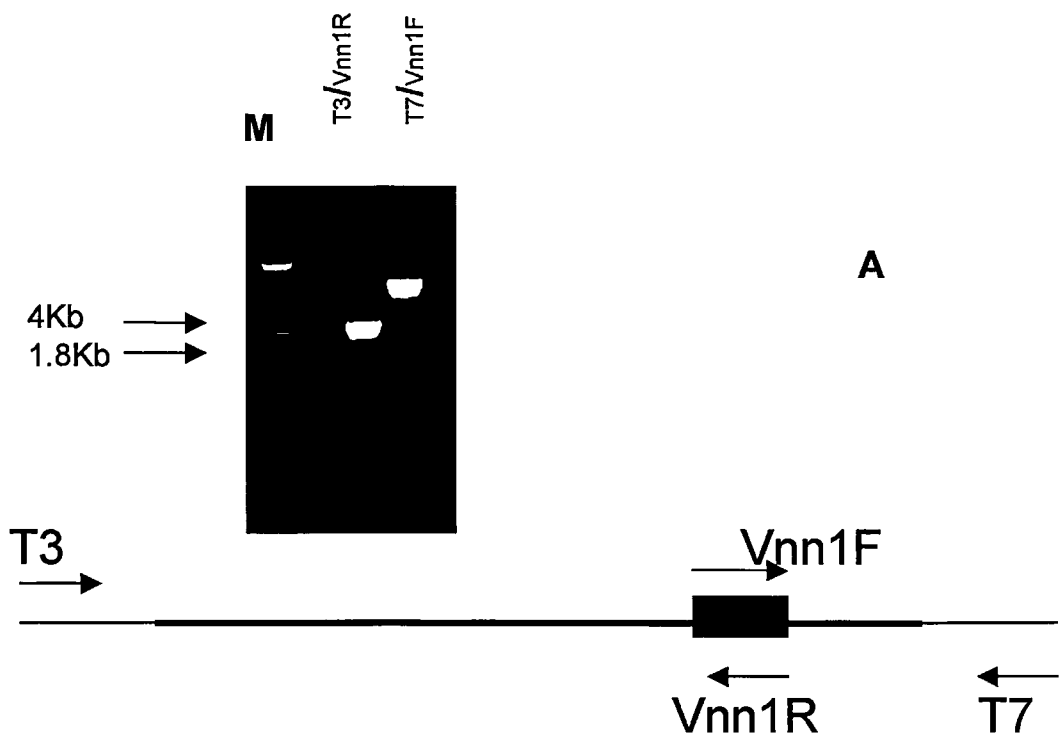
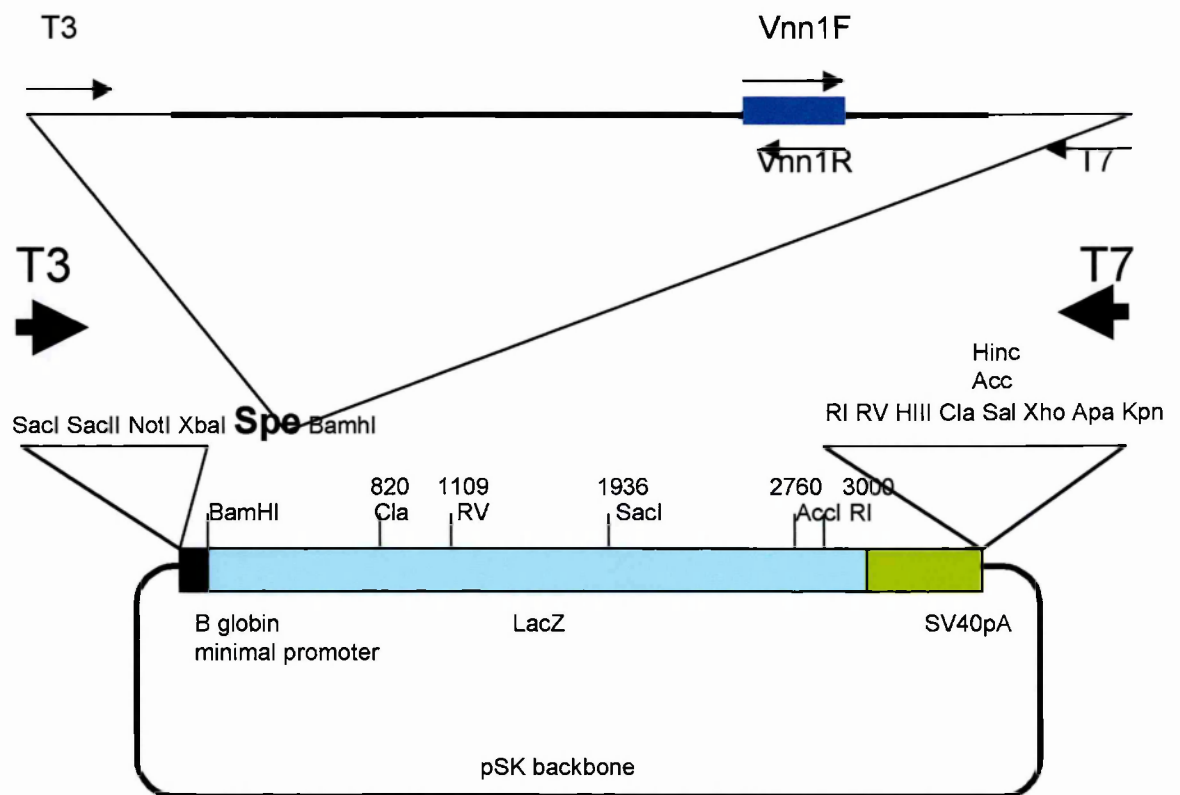

Figure 5.7

Figure 5.7 Orientation of *Vanin-1* first exon in the genomic fragment

(A) shows the gel image and schematic localization of exon one in the pBluescript subclone. PCR using the primer combinations of T3/Vnn1R and T7/Vnn1F demonstrated that the first exon is 1.8Kb from the T7 primer, with 4 Kb 3' to it. (B) shows a schematic diagram of the reporter construct P1229. This fragment was cloned into the *Spe I* restriction site of this reporter construct.



A

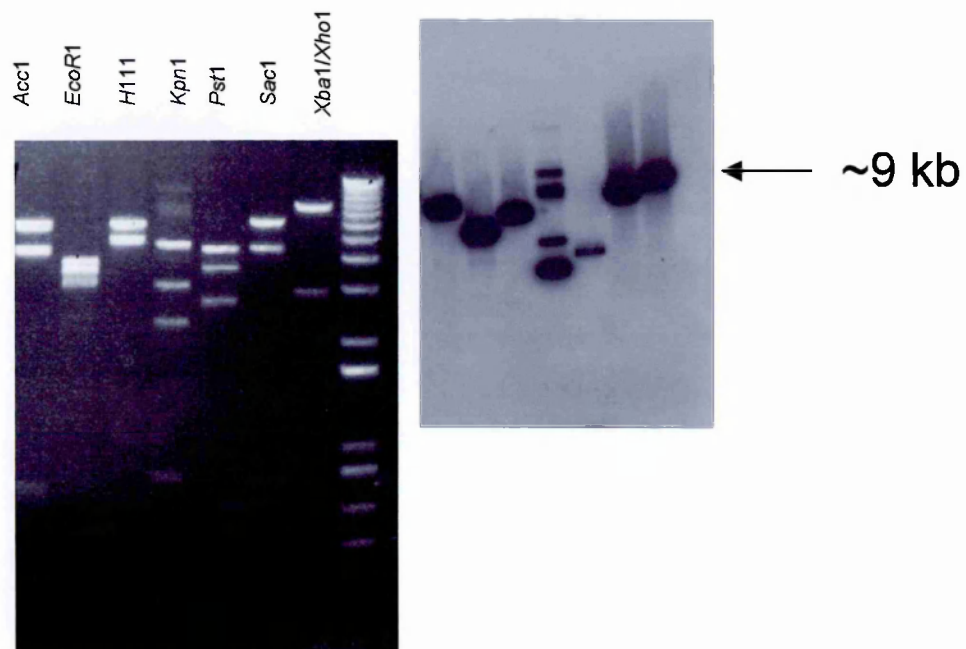

B

Figure 5.8

Figure 5.8 Cloning of genomic fragment into p1229

(A) shows a schematic diagram of the position of the fragment cloned into the reporter construct P1229. This genomic fragment was blunt ligated into the *SpeI* site of P1229. The resulting construct was cut with various restriction enzymes and probed with *Vanin-1* first exon PCR product. (B) shows the gel photograph and corresponding autoradiograph. One copy was located in each digest (except *Kpn1* which did not digest to completion).

transmit the transgene (Table 5.1). All genotyping and breeding data can be found in Appendix C.

Injection round	Number of progeny	Number containing transgene by PCR	Number passing transgene to progeny
First	29	1(male)	1
Second/Third	62	0	
Fourth	10	3 (2 male, 1 female)	3

Table 5.1 Transgenic founder mice

Table 5.1 shows a summary of the numbers of injection rounds along with the corresponding progeny founders produced, and the numbers of founders which were able to pass the transgene to subsequent progeny.

The 3 transgenic founder males and the transgene positive sons of the founder female were timed mated to C57BL/6 wild type females to produce staged embryos for the detection of *lacZ* in urogenital ridges. These were explanted from the embryos at 13.5dpc. In addition, the remainder of the embryo was collected to analyse the expression of the reporter construct in tissues outside of the urogenital ridge and to confirm the presence of the *lacZ* gene (Figure 5.9B).

No *lacZ* expression was observed in embryonic gonads at 13.5 dpc for any of the progeny of the founder mice (Table5.2, Figure 5.9C). In all cases embryos were positive for the presence of *LacZ* by PCR (Figure 5.9B).

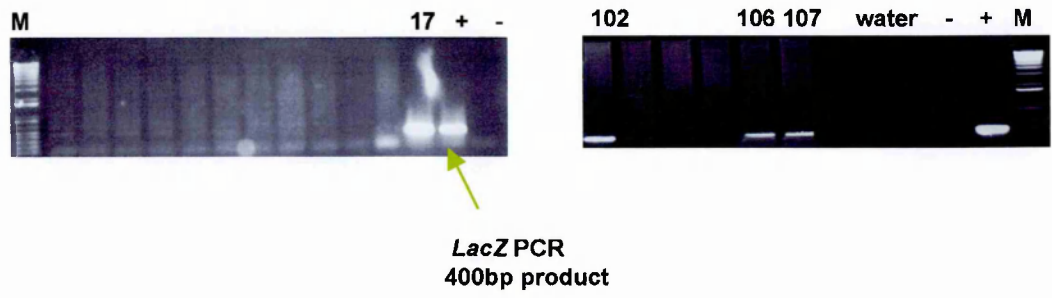

A

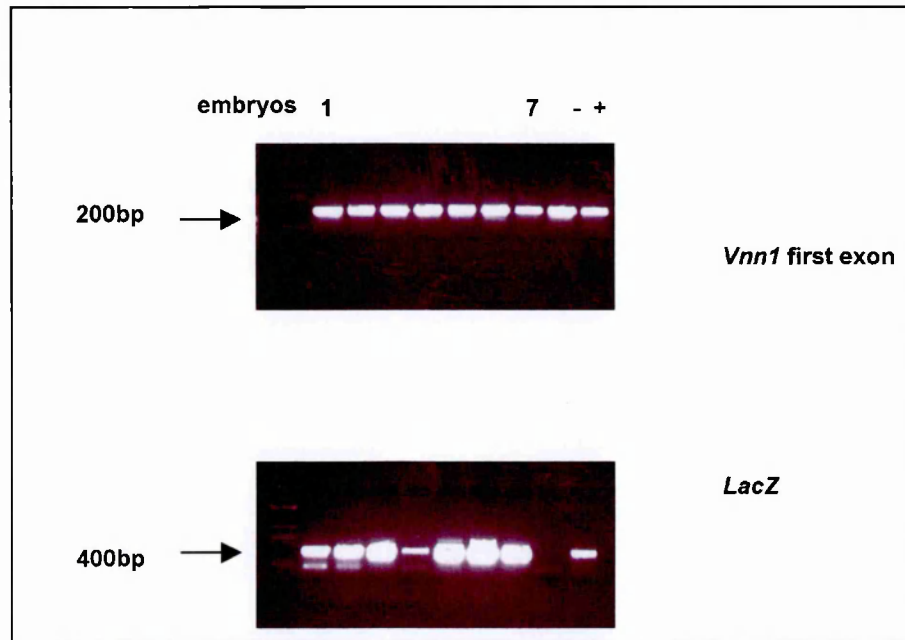

B



Figure 5.9

C

Figure 5.9 PCR genotyping potential transgenic mice and *LacZ* analysis of gonads

(A) shows a gel of the PCR results using *LacZ* primers to detect a 400bp fragment of the 3' region of the gene potentially inserted. Four mice were typed as founders: 17, 102, 106 and 107.

(B) shows a gel image of the genotyping results from timed matings, of which gonads were taken for *LacZ* staining. The same *lacZ* primers were used for this. This PCR confirmed the presence of the transgene in this litter (embryos 1-7). Primers corresponding to *Vanin-1* exon one were used to verify the integrity of the DNA used and produced a 200bp PCR product.

(C) shows an example of embryonic gonads stained for the presence of *LacZ*. No gonads at 13.5 dpc were found to express the transgene. DNA and tissue from the *LacZ* expressing mouse ROSA 26 were used as positive controls in PCR and X-Gal staining (data not shown). DNA from a 3H1 F1 hybrid mouse was used as a source of negative control DNA (A).

Founder X C57/BL6	Litters	Total number male embryos	Total number female	X-Gal positive
P17	2	2	13	0
P107	3	9	15	0
P106	1	3	7	0
P117(from female founder P102)	2	5	8	0

Table 5.2 LacZ expression in transgenic embryos at 13.5 dpc

Table 5.2 shows a summary of all litters obtained for the study of expression of the transgene in male gonads at 13.5 dpc. No gonads exhibited any positive expression.

5.6 Discussion

Microarray experiments originally indicated that *Vanin-1* expression was enhanced in the developing male gonad at 13.5 dpc. This was confirmed by WMISH. Detailed expression analysis has revealed that expression is initiated immediately prior to overt cord formation at 12.0-12.25 dpc. This observation is at slight variance with other published data (Bowles et al., 2000), where expression was first observed at 11.5 dpc. This difference could be due to differences in the strain of mice used or differences in probe and hybridisation conditions.

Expression was also limited to the Sertoli cells of the testis cord, as confirmed by the study of sections of WMISH-treated gonads and expression analysis in gonads from W^e/W^e homozygote.

As previously stated, Vanin-1 is a GPI-anchored cell-surface molecule expressed in thymic epithelial cells and is thought to be involved in the homing of bone marrow cells to the thymus. This chapter describes the expression of *Vanin-1* in an epithelial cell type of the developing testis, the Sertoli cell. A role in the regulation of cell migration might exist for Vanin-1 in this developmental context. It is known that several somatic gonadal cell types have their origin in either the mesonephros or coelomic epithelium (Karl and Capel, 1998; Martineau et al., 1997). In the case of three cell types (peritubular myoid cell, vascular endothelial cell, and myoepithelial cells) migration from the mesonephros occurs before 11.5 dpc in a male-specific fashion as an indirect consequence of *Sry* expression (Martineau et al., 1997). It has been suggested that migrating peritubular myoid cell precursors might drive testis cord formation via interaction with cells within the gonad (Tilman and Capel, 1999b). The close physical association between peritubular myoid cells and Sertoli cells suggests that it is likely that some interaction between these two cell types is required for normal cord formation. Given the expression of *Vanin-1* in the Sertoli cell lineage just prior to cord formation and its role in regulating cell homing in other contexts, it is possible that Vanin-1 regulates Sertoli cell association with and

adhesion to migrating myoid cells, either prior to or after migration of peritubular myoid cell precursors.

The expression profile of *Vanin-1* in the developing testis suggests that it is possible that *Vanin-1* expression could be regulated by a known sex-determining gene product. Hence, isolating any *Vanin-1* gonadal enhancer elements would be useful in the investigation of the role *Vanin-1* might play in gonadogenesis. To this end, a genomic fragment containing the first exon of *Vanin-1* along with approximately 4Kb upstream was cloned into a *lacZ* reporter construct and used in pronuclear injections to generate transgenic animals. If any such elements were contained in this fragment, X-Gal staining would detect expression in the developing gonads. Unfortunately, the fragment isolated did not confer any gonad specific *LacZ* expression in three independent transgenic lines. The conclusion from this is that this genomic region does not contain any such elements. Additionally, the possibility that the construct did not insert completely intact cannot be ruled out.

5.7 Summary

- *Vanin-1* is expressed in the Sertoli cells of the developing testis.
- Expression is observed initially immediately prior to overt cord formation.
- Based on the expression profile and function of the *Vanin-1* gene in other contexts, two hypotheses concerning the gonadal role of *Vanin-*

adhesion to migrating myoid cells, either prior to or after migration of peritubular myoid cell precursors.

The expression profile of *Vanin-1* in the developing testis suggests that it is possible that *Vanin-1* expression could be regulated by a known sex-determining gene product. Hence, isolating any *Vanin-1* gonadal enhancer elements would be useful in the investigation of the role *Vanin-1* might play in gonadogenesis. To this end, a genomic fragment containing the first exon of *Vanin-1* along with approximately 4Kb upstream was cloned into a *lacZ* reporter construct and used in pronuclear injections to generate transgenic animals. If any such elements were contained in this fragment, X-Gal staining would detect expression in the developing gonads. Unfortunately, the fragment isolated did not confer any gonad specific *LacZ* expression in three independent transgenic lines. The conclusion from this is that this genomic region does not contain any such elements. Additionally, the possibility that the construct did not insert completely intact cannot be ruled out.

5.7 Summary

- *Vanin-1* is expressed in the Sertoli cells of the developing testis.
- Expression is observed initially immediately prior to overt cord formation.
- Based on the expression profile and function of the *Vanin-1* gene in other contexts, two hypotheses concerning the gonadal role of *Vanin-*

1 can be immediately posited. Firstly, it may play a role in regulation of mesonephric cell migration into the gonad or, secondly, it may play a role in the regulation of Sertoli cell association with myoid cell precursors after migration in order to facilitate cord formation. However other functions cannot be ruled out. For example, given its expression in the supporting cell lineage, Vanin-1 could play a role in the development of germ cells.

Chapter 6: Organ culture studies of Vanin-1 function

6.1 Introduction

Vanin-1 is a GPI-anchored cell surface molecule originally thought to be involved in the homing of bone marrow cells to the thymus. Administration of anti-Vanin-1 monoclonal antibody (mAB 407) after sub-lethal irradiation of mice inhibits the repopulation of the thymus. It also inhibits the binding of pro-T cells to thymic sections. Previous chapters have shown that *Vanin-1* exhibits a sexually dimorphic expression profile in the developing gonad. Transcripts are only found in the male gonad and are restricted to the Sertoli cells of the testis cords. This expression is first observed at 12.0 dpc, immediately prior to overt cord formation.

As mentioned previously, the expression of the sex determining gene *Sry* is required for the supporting cell precursors in the XY gonad to commit to the Sertoli cell fate, and therefore to initiate sexual differentiation. However, the identity of signals from the Sertoli cells that function in the masculinisation of other somatic lineages remains unclear. In addition, how cell-cell communication results in the development of testicular morphology is poorly understood.

Studies employing *in vitro* culturing of explanted gonads have shown that the development of the characteristic architecture of the testis is dependent on the male-specific migration of precursor cells from the mesonephros into the gonad (Martineau et al., 1997). This migration is induced by the production of a testicular chemoattractant that is dependent on *Sry* activity

(Capel et al., 1999). Other processes required to produce the characteristic testicular morphology include increased vascularisation and cell proliferation and these are also dependent on Sertoli cell products (Martineau et al., 1997; Schmahl et al., 2000). Martineau et al. also demonstrate that migratory peritubular myoid cells surround the Sertoli cells within the gonad. Sertoli cells and peritubular myoid cells interact to form testicular cords, separated by a basement membrane.

Three key observations relating Vanin-1 to testis development can be noted:

- 1 The location and timing of *Vanin-1* expression: it is restricted to the pre-Sertoli cells, immediately prior to cord formation.
- 2 *Vanin-1* is a cell surface molecule.
- 3 *Vanin-1* is thought to be involved in thymic homing.

Given these observations, two possible roles for *Vanin-1* in male gonad development stand out:

- 1 It is required for cell migration from the mesonephros into the male gonad.
- 2 It is involved in the post-migrational organisation of gonadal cells into testis cords.

Other functions could also be attributed to *Vanin-1* also, for example, functions relating to germ cell development. However, the association between the expression of *Vanin-1* and testis cord formation and its

described role in thymus development both suggest that its putative morphogenetic function should be investigated further.

Given the efficacy with which anti-Vanin-1 mAb 407 has previously been used to block Vanin-1 thymic function *in vitro* it was decided to test the consequences of blocking Vanin-1 activity in cultured embryonic gonads using the same antibody.

Previous studies have demonstrated that male gonads, when cultured, will form testis cords at the same rate as *in vivo* (Brennan et al., 1998; Capel et al., 1999; Yao et al., 2003). Many established organ culture systems have also exploited the use of antibodies to study the effect of protein blocking, most notably kidney and lung organ culture studies (Davies et al., 1999; Falk et al., 1996; Hirai et al., 1992; Schuger et al., 1991; Sorokin et al., 1992; Talts et al., 1997). However, studying how embryonic gonads react to the presence of specific antibodies in culture has not been reported.

6.2 Aim of this chapter

The aim of this chapter is to study the effects of the presence of anti-Vanin-1 monoclonal antibody (mAb 407) on the normal development of the embryonic male gonads when explanted into culture, in comparison to gonads cultured without mAb 407 or in the presence of a non-specific antibody.

6.3 Strategy

- mAb 407 was used in an immunohistochemical analysis of cryosections of developing gonads in order to show that this antibody detected Vanin-1 in a similar pattern to transcripts seen in WMISH.
- Urogenital ridges (UGRs) of approximately 11.5 dpc, prior to overt cord formation, were dissected and sexed. Each UGR was cut in two and one gonad/mesonephros pair was placed in culture containing mAb 407, the other was placed in a control culture containing no antibody or containing mAb 31.9 (Figure 6.1). This antibody was generated in the same way as mAb 407 and was part of the same original screen.
- Cultures were incubated for 48 hours with one change of media. After this period they were scored according to how efficiently they formed testis cords: 0 = no cord formation; + = partial cord formation; and ++ = full cord formation.
- The efficiency of cord formation was also assessed by performing WMISH and immunohistochemistry using various cell markers found in the developing testis.

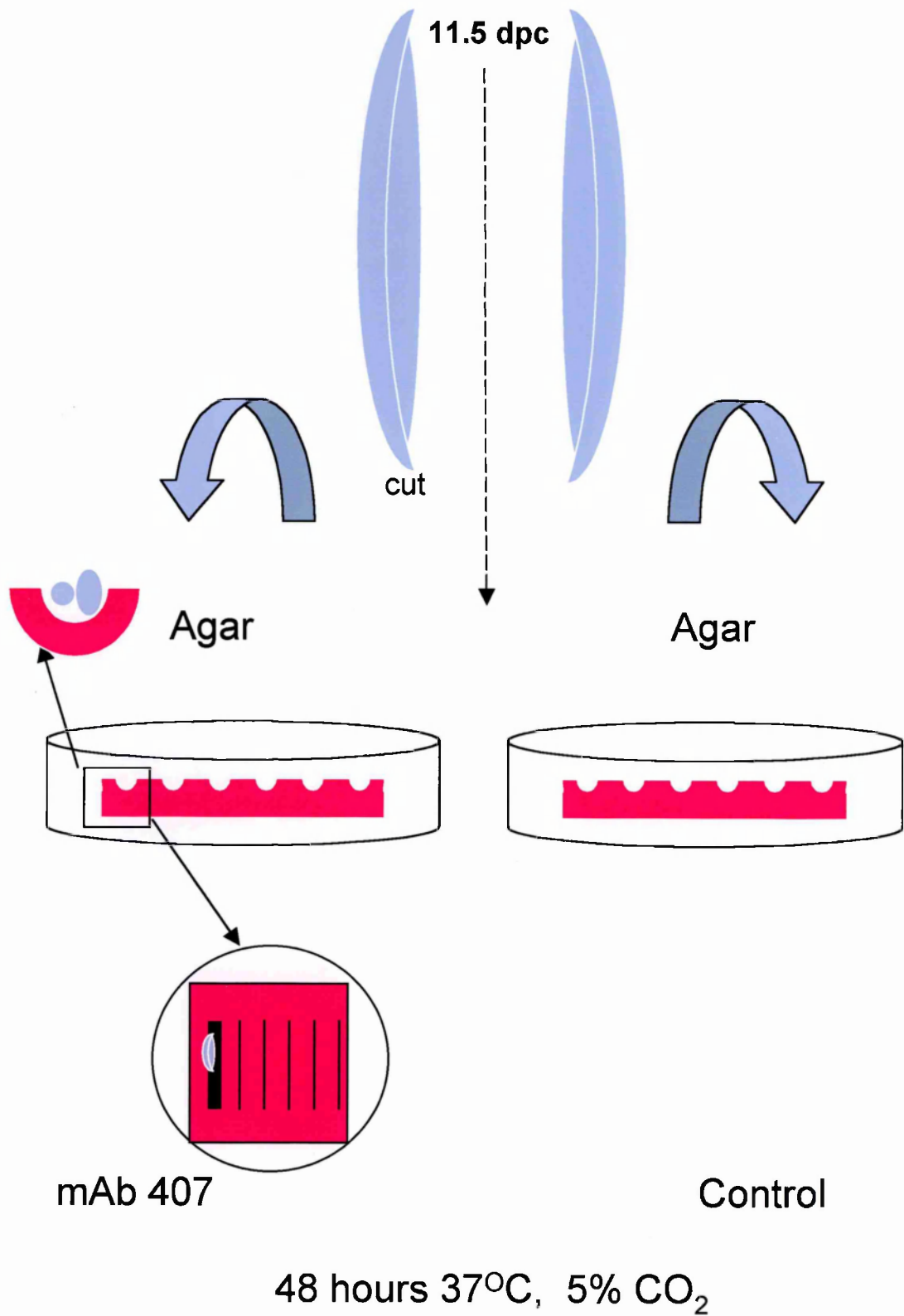

Figure 6.1

Figure 6.1 Organ culture strategy

Figure 6.1 shows a schematic diagram describing the organ culture strategy. Each male UGR is cut in two, one gonad/mesonephros pair incubated in agar grooves in the presence of mAb 407 and the other in a control dish. Cultures are incubated for 48 hours during which time gonad development proceeds.

6.4 Results

6.4.1 mAb 407 detects Vanin-1 in a similar pattern to WMISH

On receipt of the anti-Vanin-1 monoclonal antibody (a kind gift from P. Naquet), it was tested in order to verify its ability to detect Vanin-1 on sections of male and female gonads, and thereby also to confirm the sexually dimorphic expression of Vanin-1 protein in the developing gonad.

Cryosectioned tissue from developing male and female gonads was incubated with mAb 407 for 45 minutes and then with anti-mouse FITC IgG for a further 45 minutes. Staining was visualized under ultraviolet light. Expression of Vanin-1 protein reflects the expression pattern of *Vanin-1* transcripts (Figure 6.2). Protein is localised in the developing testis cords at 12.5 dpc (Figure 6.2B), and is concentrated towards the periphery of the testis cord at 13.5 dpc (Figure 6.2C). At 15.5 dpc Vanin-1 continues to be expressed in a sexually dimorphic manner, with protein found in the Sertoli cells of the testis cords, (Figure 6.2D). No expression is observed in the developing ovary (left panel Figure 6.2).

6.4.2 Expression of mAb 31.9, a non-specific monoclonal antibody

To show that any effects on the development of male gonads in culture is not due to any general effect of adding extra molecules into the culture media,

1. The first part of the document discusses the importance of maintaining accurate records of all transactions and activities. It emphasizes that this is crucial for ensuring transparency and accountability in the organization's operations.

2. The second part of the document outlines the various methods and tools used to collect and analyze data. It highlights the need for consistent and reliable data collection processes to support effective decision-making.

3. The third part of the document focuses on the role of technology in data management and analysis. It discusses how modern software solutions can streamline data collection, storage, and reporting, thereby improving efficiency and accuracy.

4. The fourth part of the document addresses the challenges associated with data management, such as data quality, security, and integration. It provides strategies to overcome these challenges and ensure the integrity and availability of data.

5. The fifth part of the document discusses the importance of data governance and compliance. It outlines the necessary policies and procedures to ensure that data is handled in a responsible and lawful manner, meeting regulatory requirements.

6. The sixth part of the document concludes by summarizing the key points and emphasizing the ongoing nature of data management. It stresses the need for continuous monitoring and improvement to stay ahead of the ever-evolving data landscape.

7. The final part of the document provides a list of references and resources for further reading on data management topics, including books, articles, and industry reports.

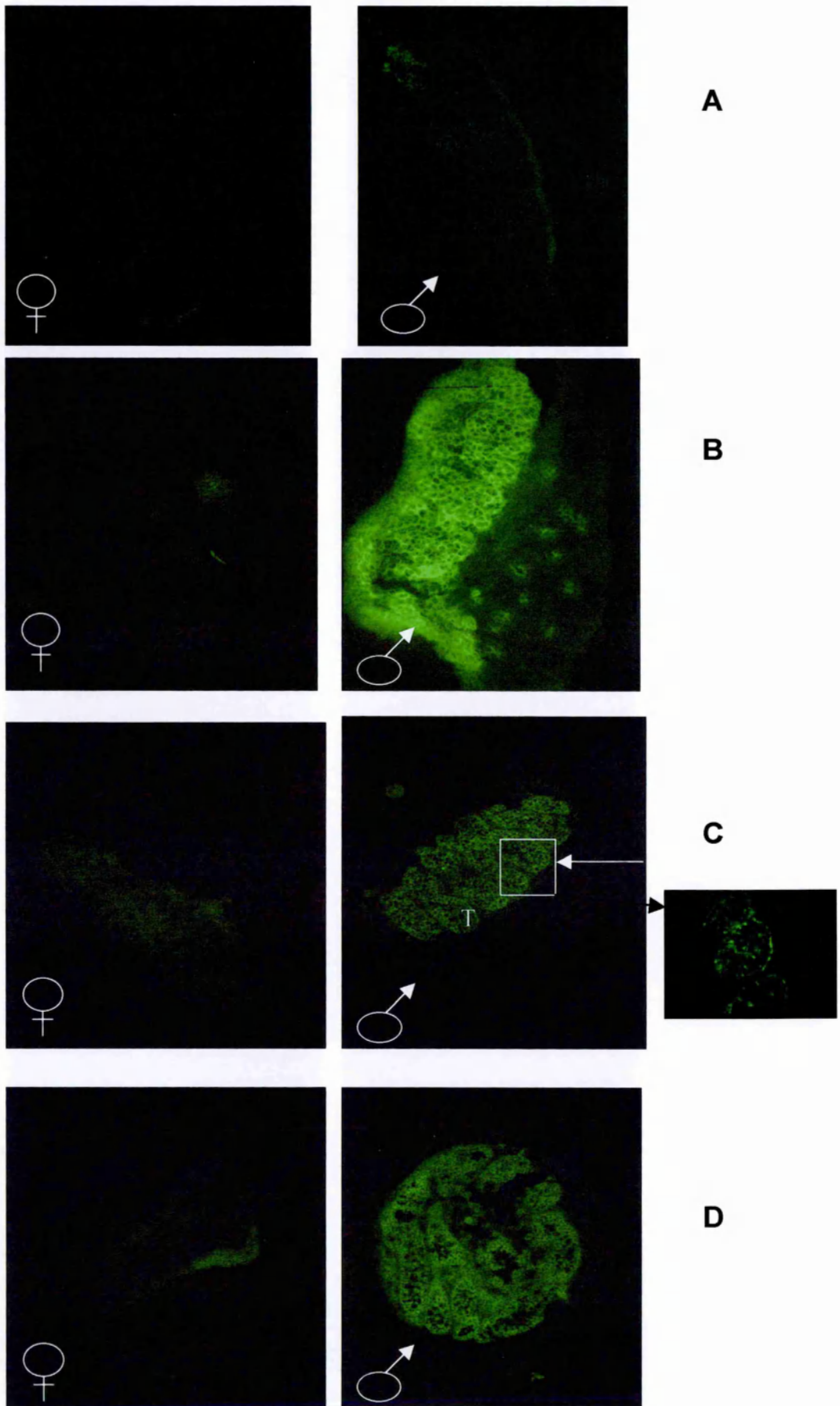

Figure 6.2

Figure 6.2 mAb 407 immunostaining results in a similar pattern to WMISH analysis using *Vanin-1* riboprobe

Figure 6.2 shows immunostaining results on gonads using mAb 407. No staining is seen in either the developing ovary or testis at 11.5 dpc (A). At 12.5 dpc mAb 407 detects protein in the developing testis cords (B). At 13.5 dpc this staining is concentrated towards the periphery of the testis cords (T, arrow, magnified in box) (C). This pattern is also seen at 15.5 dpc (D). No significant staining is observed in the developing ovary at any stage (left panel), or with secondary antibody alone (data not shown).

and to assess any effect of the addition of antibodies with a similar structure, mAb 31.9 was added to a subset of culture experiments.

This antibody originated in the same laboratory as mAb 407, and was generated as part of the same screen which isolated mAb 407 and hence was also a gift from P.Naquet. Binding of mAb 31.9 was investigated in cryosectioned embryonic male gonads at 13.5 dpc. No expression was detected in either the gonad or mesonephros (Figure 6.3).

6.4.3 Visual assessment of cord formation in culture

Cultures were set up according to the strategy laid out in Figure 6.1. Urogenital ridges were dissected at 11.0-11.25 dpc (corresponding to 17-21 tail somites) into single wells. They were stored on ice in culture media as described in section 2.17 whilst the sex was determined. Male UGRs were kept and dissected into gonad/mesonephros pairs. Initially, cultures were set up to assess the efficiency of this culture method on the development of testis cords. Under these conditions typically 80-85% of male UGRs formed testis cords (Figure 6.4A).

6.4.4 Test cultures

During test cultures, one pair was placed in culture along with mAb 407, and the other either with mAb 31.9 or in an antibody-free control. After approximately 48 hours, cultured gonads were scored for cord formation.

The clear presence of well formed cords was scored as “++”, partial cord formation as “+”, and “0” denotes a complete absence of cords (Figure 6.4 B, C, D).

6.4.5 Organ culture assays: scoring effects by visual inspection

Nine independent experiments were performed. In these experiments there was a significant effect on the ability of gonads cultured in the presence of mAb 407 to form testis cords in comparison to controls (Figure 6.5).

Experiments 1-6 show a distinct trend: cords form in most cases in the absence of mAb 407 but there is a complete failure to do so in its presence. However, experiments 7-9 exhibited a less marked effect: a subset of gonads form testis cords in the presence of the antibody (Figure 6.6).

To determine whether this was due to failure of the antibody to penetrate the tissue, these gonads were frozen, sectioned and treated with secondary antibody (Figure 6.7). In all cases signal was observed within the testis cords, excluding lack of penetration as an explanation. In the case of those gonads that failed to form cords, secondary antibody treatment revealed presence of mAb 407 throughout the gonad (data not shown).

One possible explanation is that these gonads were slightly older when put into culture and hence cord formation had already been initiated at the start of the culture period.

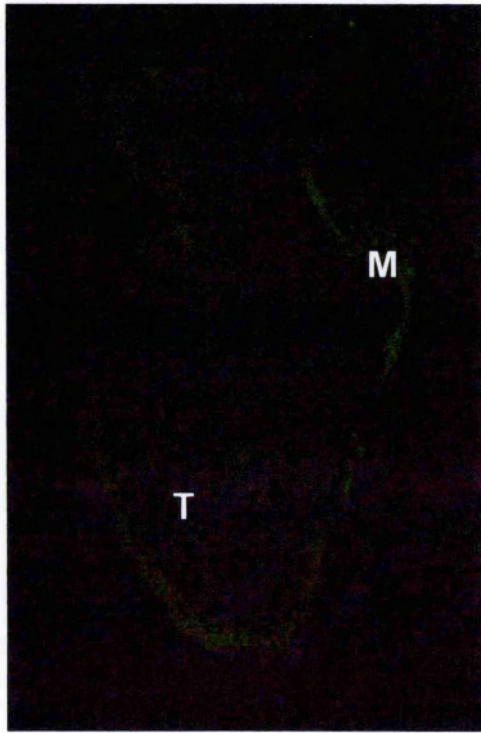
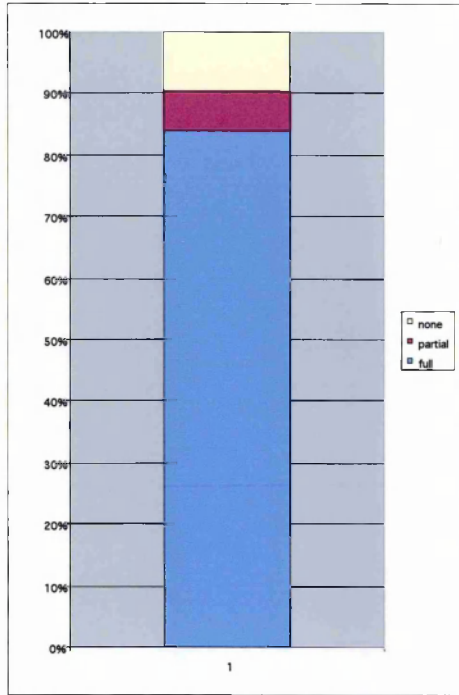

Figure 6.3

Figure 6.3 Binding of mAb 31.9 at 13.5 dpc

Figure 6.3 shows immunostaining results using the mAb 31.9, a non-specific monoclonal antibody on a gonadal section at 13.5 dpc. No expression is seen in either the testis (T) or mesonephros (M) of the male gonad.



A

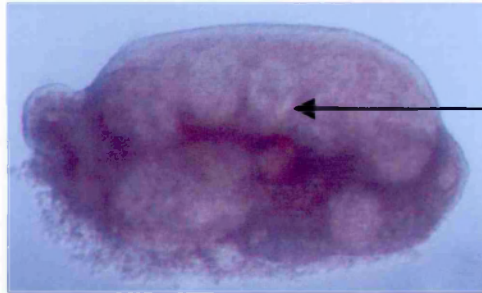

B

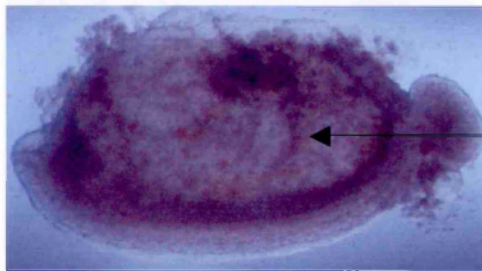

C

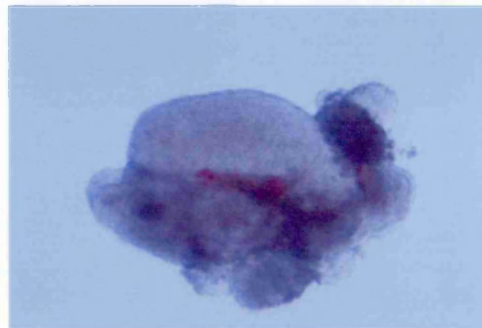

D

Figure 6.4

Figure 6.4 Initial cultures and cord formation: Score

Figure 6.4 (A) shows the percentages of gonads which either form testis cords, show a partial formation, or no cord formation after *in vitro* culture for 48 hours. Typically, over 80% of male gonads when cultured under the conditions described in section 2.18 and 6.3 will form testis cords.

Figure 6.4 (B, C and D) show photographs taken under a light microscope of gonads cultured for 48 hours. When testis cords are clearly visible (arrow) they are scored ++ (B). Cultures are scored + when some signs of cord formation are apparent, but with no obvious cords forming (C). When no cords form cultures are scored as 0 (D).

6.4.6 Markers used in the analysis of cultured gonads

To determine whether those gonads that had failed to form cords exhibited any other signs of abnormal gonadal differentiation, the expression of three lineage markers indicative of testicular differentiation was studied.

Sox9 is a marker of Sertoli cells (da Silva et al., 1996; Kent et al., 1996), *Oct4* is a marker of primordial germ cells (Pesce et al., 1998), both of which are located in the testis cords, and *3 β HSD* is a marker of interstitial Leydig cells (Vainio et al., 1999) (Figure 6.8).

6.4.7 Marker analysis of cultured gonads

Examination of control gonads that had formed cords normally in culture indicated that all three markers were expressed in the appropriate region of the testis. However, gonads that had failed to form testis cords in culture in the presence of mAb 407 also gave positive signals for all three markers, but in all cases cells showing expression were apparently not organised into cord-like structures. In control cultures, *Sox9* expression is located towards the periphery of the testis cords (Figure 6.9A), whereas in test cultures expression is more random (Figure 6.9B). *Oct4* also exhibits normal expression in control cultures (Figure 6.10A) with transcripts in the centre of the cords.

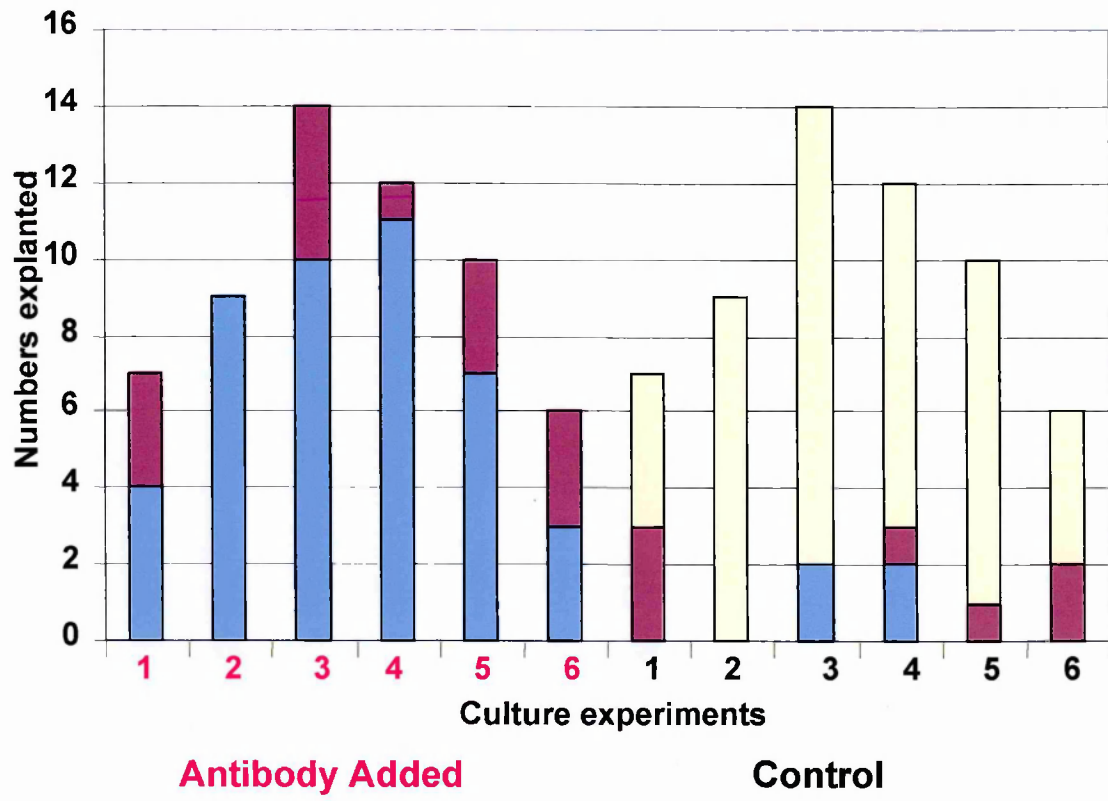

- No cord formation
- Partial cord formation
- Full cord formation

Figure 6.5

Figure 6.5 Effect of culturing XY gonads in the presence or absence of mAb 407: experiments 1-6

Figure 6.5 shows a bar chart incorporating the actual numbers of gonads placed in culture in the presence and absence of mAb 407. The first half of the graph shows results of adding the antibody. Adding mAb 407 inhibits testis cord formation in culture, as the majority of gonads do not form testis cords after 48 hours in culture. This effect is most marked in experiments 1-6. In contrast the second half of the graph shows the effects of culturing the other half of the UGR without mAb 407. Here the majority do form testis cords.

Chi-square was calculated for all experiments as 41.86 (df=2 P=0.0000000081), revealing a significant difference between cord forming ability in the presence and absence of mAb 407.

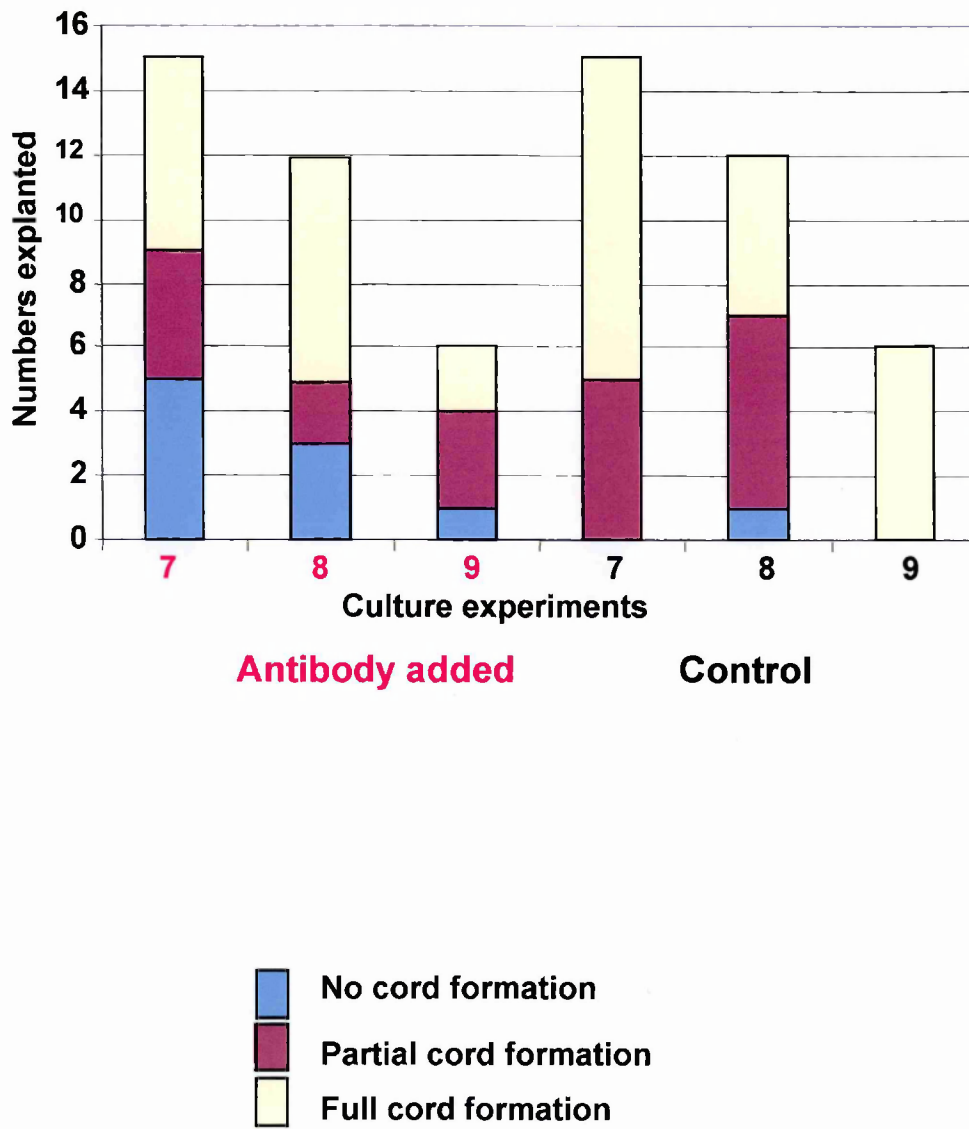

Figure 6.6

Figure 6.6 Effect of culturing XY gonads in the presence or absence of mAb 407: experiments 7-9

Figure 6.6 shows a bar chart of the culture results in three further culture experiments. In these three experiments this effect was less marked. Cords formed in gonads cultured in the presence of mAb 407 as can be seen in the first half of the graph, though in a reduced capacity.

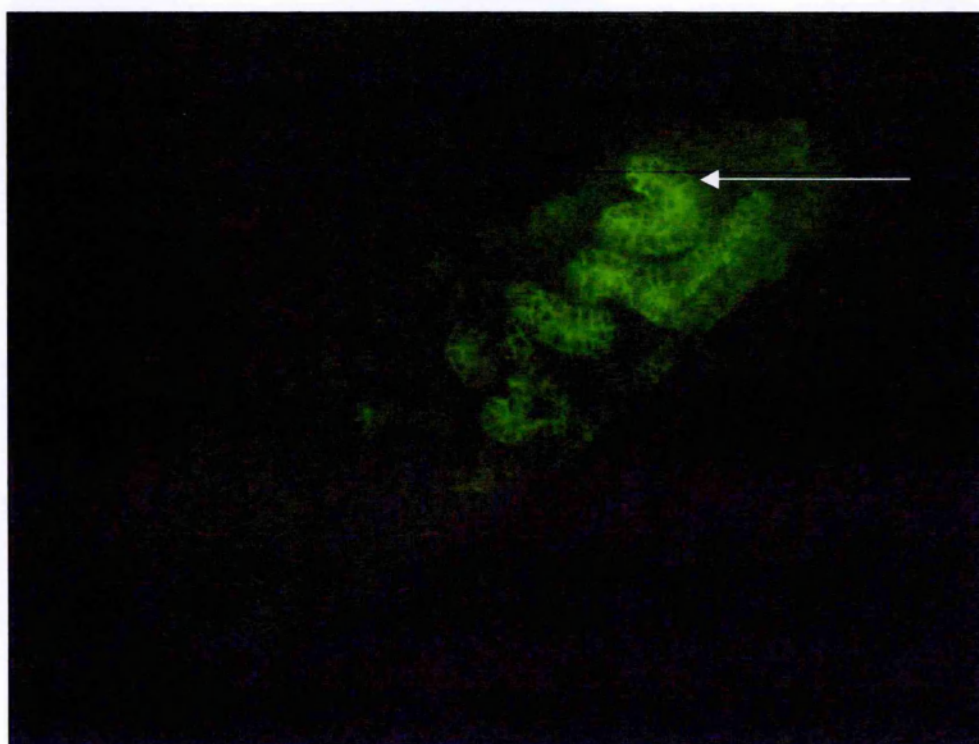

Figure 6.7

Figure 6.7 Detection of mAb 407 in cultured gonads

Figure 6.7 shows immunostaining results of a cultured gonad which formed testis cords in the presence of mAb 407. Using the secondary antibody alone, mAb 407 was detected in this gonad and was localised to the testis cords (arrow).



A

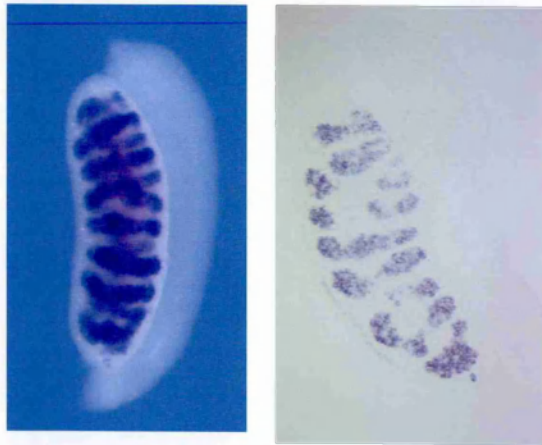

B

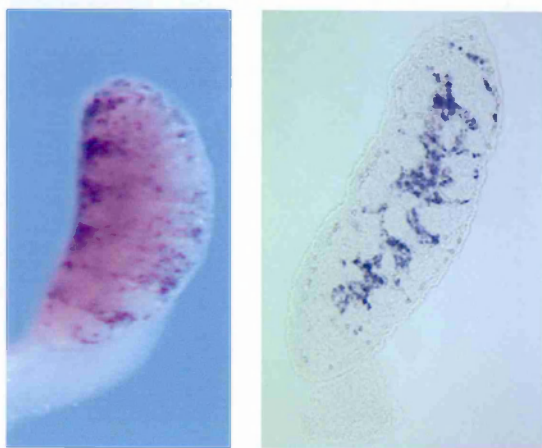

C

Figure 6.8

Figure 6.8 Three cell markers of testis development

The pattern of expression of various testicular cell markers by WMISH on male gonads at 13.5 dpc is shown. *Sox9*, a Sertoli cell marker, is expressed in the testis cords. Longitudinal sections show how this staining is seen as a smooth edge around the periphery of the testis cords in the region of the Sertoli cells (A). *Oct4*, a primordial germ cell marker, is expressed in the germ cells in the centre of the cord. Longitudinal sections of this gonad reveal expression to be located towards the centre of the cord without the smooth edge seen in *Sox9* stained gonads (B). *3βhsd*, a marker of Leydig cells, is found in the interstitium, between the testis cords. These cells can clearly be seen outside the testis cords in longitudinal sections (C).

In test cultures, expression is again randomly distributed (Figure 6.10B). In control cultures 3β HSD-positive cells appear as lines (Figure 6.11A). In sections of control cultures, expressing cells are distributed randomly (Figure 6.11B).

These data suggest that the ability of the gonads to form differentiated testicular cell-types has been unaffected by the presence of the mAb 407. However, it can be seen that there is a loss of male pattern in treated gonads. The failure of cords to form is confirmed by the loss of the distinct pattern of expression by testicular cell markers.

6.4.8 Effects of mAb 407 on the formation of the basement membrane

As the testis develops, cords become organised within it. Germ cells are surrounded by Sertoli cells; peritubular myoid cells surround the Sertoli cells and are separated from them by a basal lamina. Indeed, cooperativity between Sertoli cells and peritubular myoid cells probably occurs in order to produce and deposit this basement membrane (Tung and Fritz, 1987; Tung et al., 1984). One key component of a basement membrane is laminin. Therefore, the pattern of laminin expression was examined in gonads cultured in the presence of mAb 407.

Initially, laminin expression was examined in 13.5 dpc gonads. A concentration of protein is seen at the edge of the testis cord, corresponding to the presence of a basal lamina (Figure 6.12A).



A

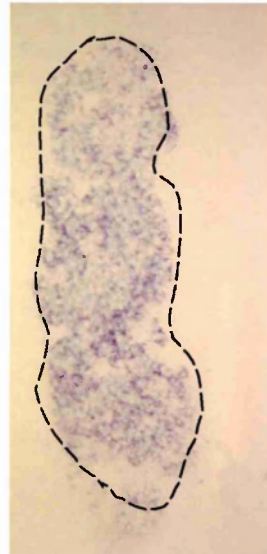
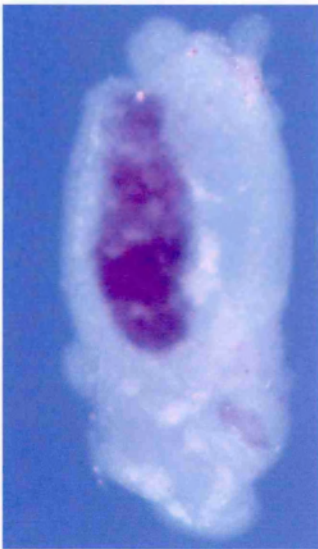

B

Figure 6.9

Figure 6.9 Expression of Sox9 in cultured gonads

Figure 6.9 shows WMISH analysis on gonads cultured in the presence and absence of mAb 407. Sox9 is expressed in the cords which develop in control cultures. Expression is observed mainly at the periphery of these cords (A) Transcripts are still detected in test cultures, however, expression is seen throughout the gonad (B).

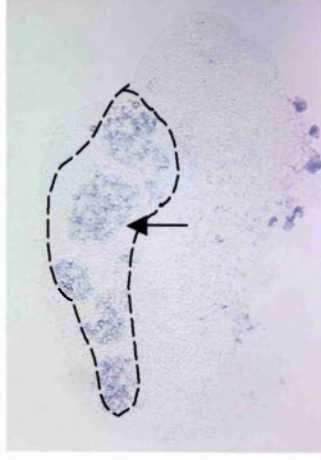

A

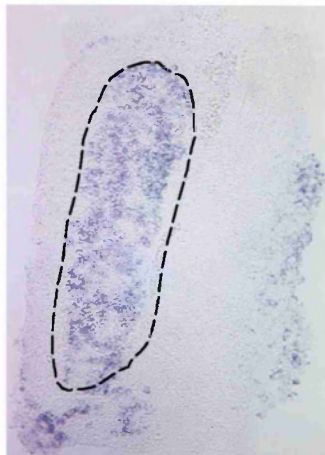

B

Figure 6.10

Figure 6.10 Expression of *Oct4* in cultured gonads

Oct4 expression analysis by WMISH on test and control gonads cultured in the presence or absence of mAb 407 is shown. *Oct4* can be detected in the centre of the testis cords in control cultures (A, arrow).

This pattern of expression is lost in test cultures, with transcripts found throughout the length of the gonad (B).

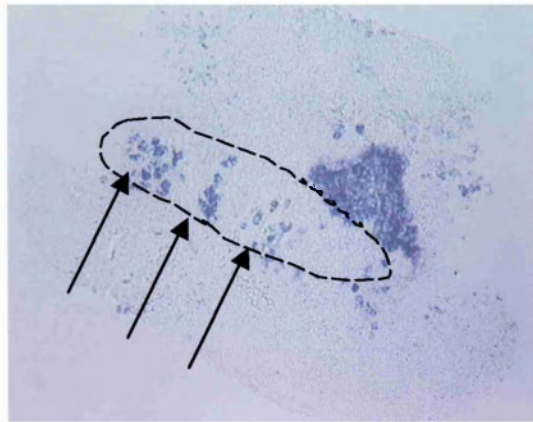
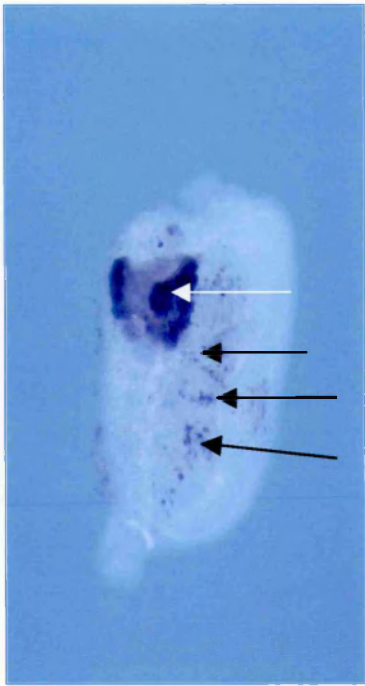

A

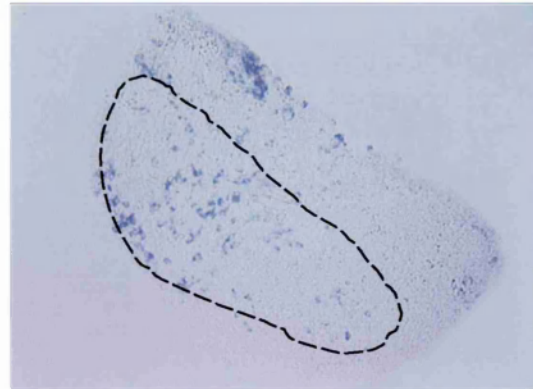

B

Figure 6.11

Figure 6.11 Expression of 3 β HSD in cultured gonads

3 β hsd expression analysis by WMISH on gonads cultured in the presence and absence of mAb 407 is shown. The area at the anterior end of the gonad exhibiting high levels of expression corresponds to the adrenal gland which is present in these cultures (white arrow). Expression in the gonad is also concentrated between the testis cords (black arrows) in control cultures (A). This pattern is lost in test gonads and positive cells are distributed randomly (B).

In female gonads no such organisation of expression is seen although discrete zones of expression are observed (Figure 6.12B).

When gonads were cultured either in control media alone, or in the presence of mAb 31.9, the pattern of laminin protein localisation is similar to that noted in 13.5 dpc male gonads (Figure 6.13A, B). However, when gonads are cultured in the presence of mAb 407, this pattern is lost and the protein becomes localised to the periphery of the gonad (Figure 6.13C).

6.4.9 Effects of mAb 407 on migratory cell-types

From the above results two points can be concluded:

- 1- Anti-Vanin-1 antibody inhibits cord formation in XY gonad cultures.
- 2- Affected male gonads continue to differentiate testicular cell types as defined by marker gene expression but these are disorganised.

Two possibilities can account for this loss of testis cord formation *in vitro*:

- 1- Blocking of Vanin-1 by mAb 407 could affect the efficiency of mesonephric cell migration into the gonad, a requirement for testis cord formation.
- 2- Blocking of Vanin-1 function could be affecting the post-migrational organisation of gonadal cells into testis cords.

Several studies have shown that cell migration from the mesonephros is required for the development of testis cords.

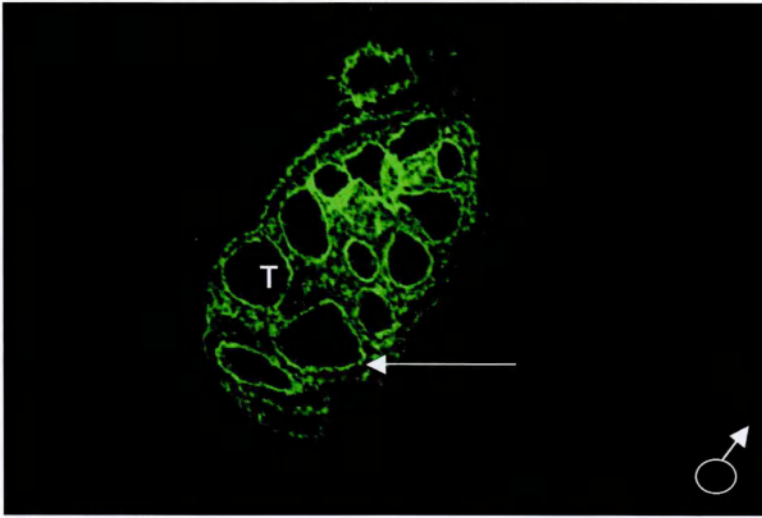

A

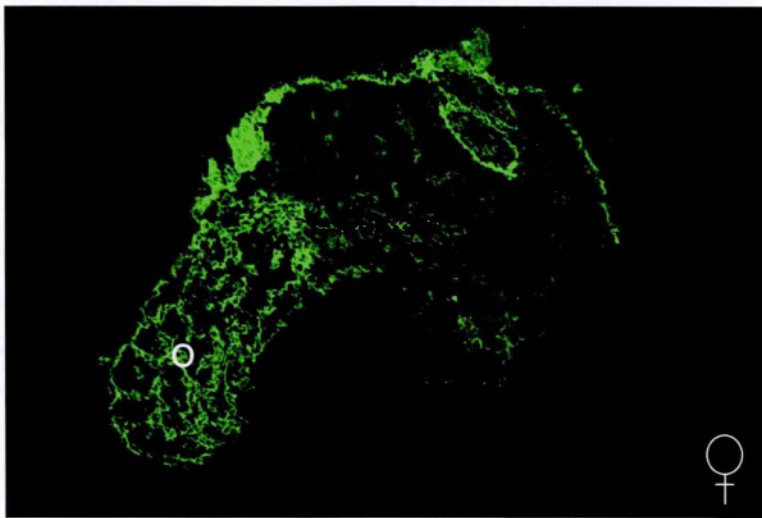

B

Figure 6.12

Figure 6.12 Laminin localisation in 13.5 dpc gonads

Immunostaining results are shown using an antibody to detect laminin of cryosections of gonads at 13.5 dpc. Expression of laminin is concentrated around the edge of the testis cords (white arrow, A). Some generalised expression is seen between the testis cords; however, the testis cord itself has a complete absence of signal (T). Laminin expression in the ovary is also in a well organised pattern (B).

T, testis cord; O, ovary.

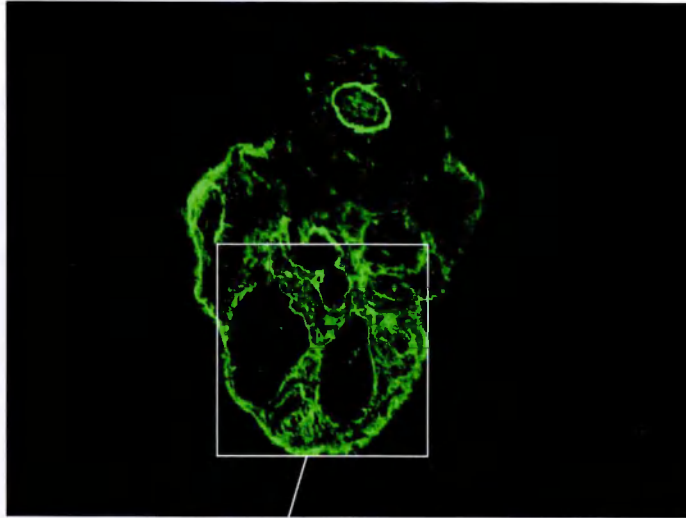

A

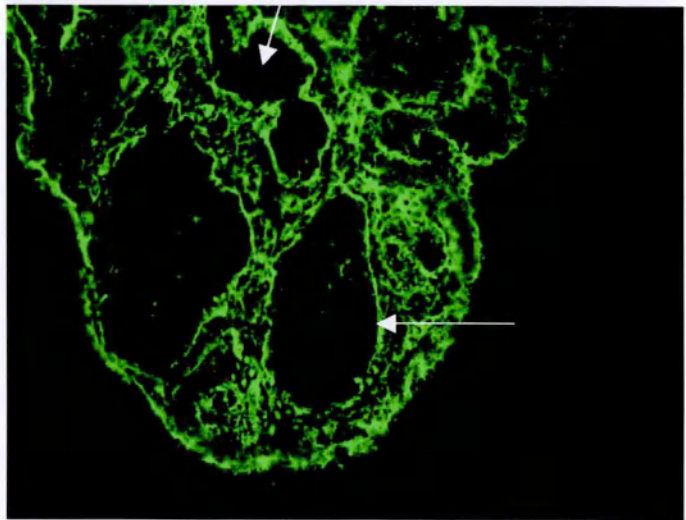

B

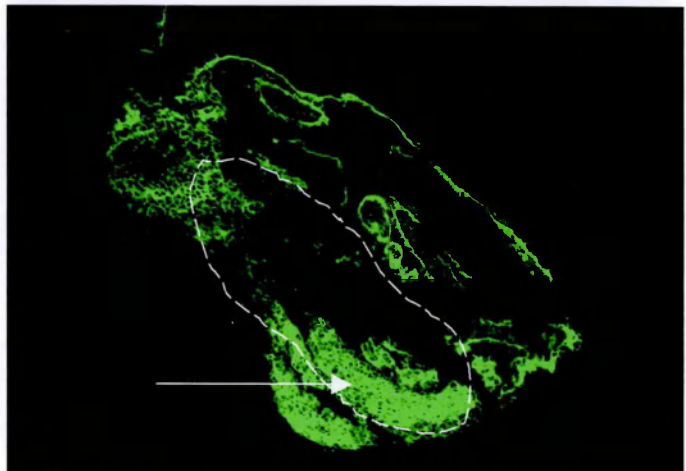

C

Figure 6.13

Figure 6.13 Laminin antibody staining of gonad cultures

Immunostaining results are shown using an antibody to laminin on gonads cultured in the absence or presence of mAb 407. In gonads cultured in the absence of mAb 407 laminin protein expression is localised to the outside of the testis cord in a similar pattern to expression seen in 13.5 dpc male gonads (A). This can be clearly seen at a higher magnification (B). This expression pattern is lost in gonads cultured in the presence of mAb 407 with expression concentrated towards the periphery of the gonad (white arrow).

One cell-type which migrates into the gonad from the mesonephros and is critical for cord formation is the peritubular myoid cell (PMC) (Merchant-Larios et al., 1993).

To date no definitive marker for peritubular myoid cells exists. Therefore, the expression of two potential markers of PMC's was studied in gonads cultured in the presence and absence of mAb 407.

6.4.9.1 p75NTR: a marker of peritubular myoid cells?

Mesenchymal cells that migrate from the mesonephros into the gonad to form PMCs can be identified by the presence on their surface of the p75 neurotrophin receptor (p75NTR) (Campagnolo et al., 2001). p75NTR-positive cells appear to migrate from the mesonephros into the male gonad: these cells do not appear in the gonad unless a mesonephros is attached. Furthermore, p75NTR-positive cells differentiate into myoid cells *in vitro* (Campagnolo et al., 2001).

Expression of p75NTR was studied at 12.5 dpc and 13.5 dpc in male gonads using a polyclonal antibody. It can be seen that localisation of the protein was observed between the testis cords, in the area associated with the localisation of PMCs (Figure 6.14 A, B). PMCs are located around the edge of the Sertoli cells; however p75NTR does exhibit a more widespread pattern indicating that other interstitial cells may be positive for this marker. No

immunofluorescence was observed in sections treated with secondary antibody alone (data not shown).

Gonads cultured in the presence and absence of mAb 407 were stained with anti-p75NTR (Figure 6.15). In control gonads (where no mAb 407 was added) p75NTR expression was localised around the testis cords in the interstitium. Staining was absent from the cords, as indicated by the corresponding expression of alkaline phosphatase, a marker of germ cells, in adjacent sections (Figure 6.15A). However, the staining pattern seen in cultures incubated with mAb 407 was markedly different, and was restricted to the very edges of the gonad, and completely absent from the centre. The appearance of such cord-free male gonads is reminiscent of one very large testis cord (Figure 6.15B).

6.4.9.2 Expression of *Patched-1* in gonad cultures

Patched-1 (*Ptc-1*) is expressed in both peritubular myoid cells (Bitgood et al., 1996; Clark et al., 2000) and Leydig cells (Yao et al., 2002). It is the receptor of Desert Hedgehog, which itself is expressed in Sertoli cells. Expression of *Ptc-1* was examined in control and test gonad cultures. In control cultures (Figure 6.16A), expression is found between the testis cords in the region where peritubular myoid cells are located; this can be clearly seen in cross section.

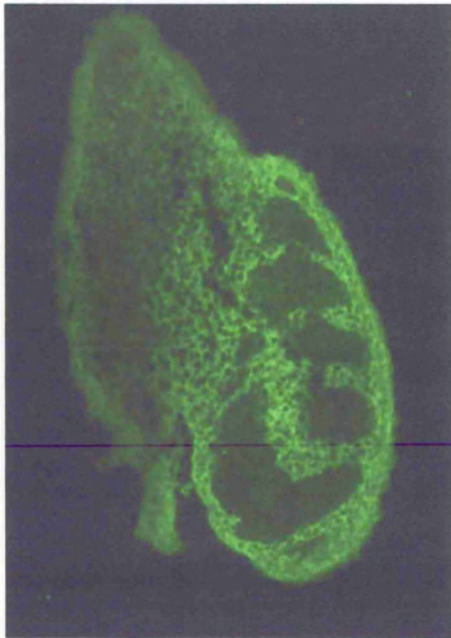

A

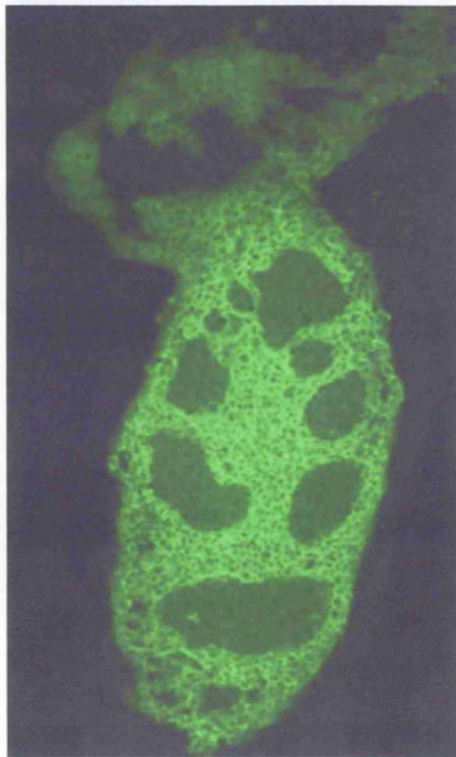

B

Figure 6.14

Figure 6.14 Localisation of p75NTR in 12.5 and 13.5 dpc male gonads

Figure 6.14 shows immunostaining of male gonad sections at 12.5 and 13.5 dpc with an antibody to p75NTR. Expression is observed around the developing testis cords at 12.5 dpc (A). Expression is still confined to the interstitium in the male gonad at 13.5 dpc (B), but this expression is more widespread than the location of peritubular myoid cells.

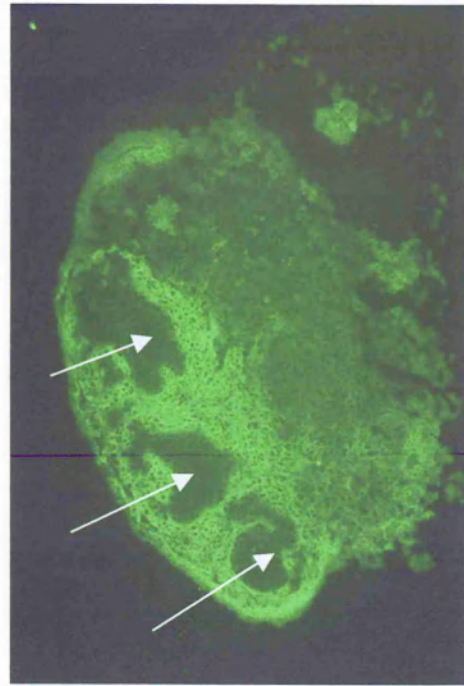
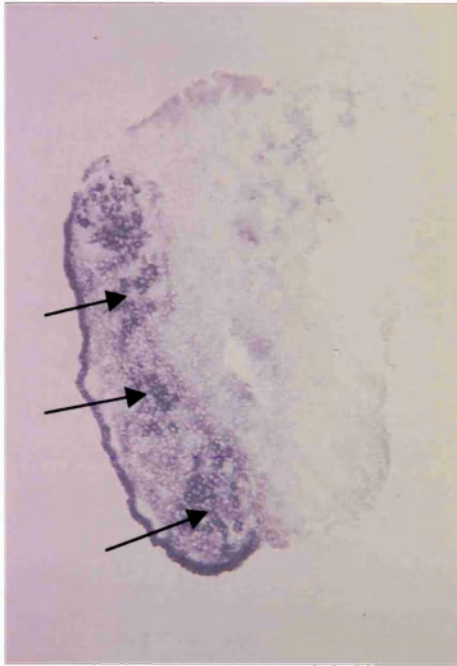

A

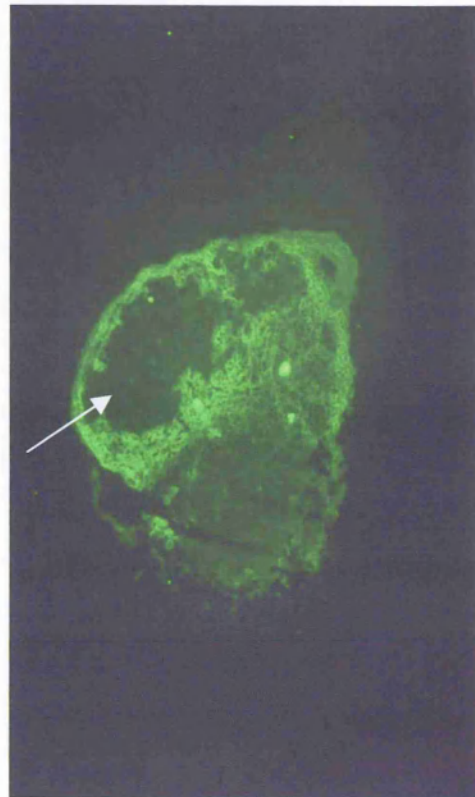
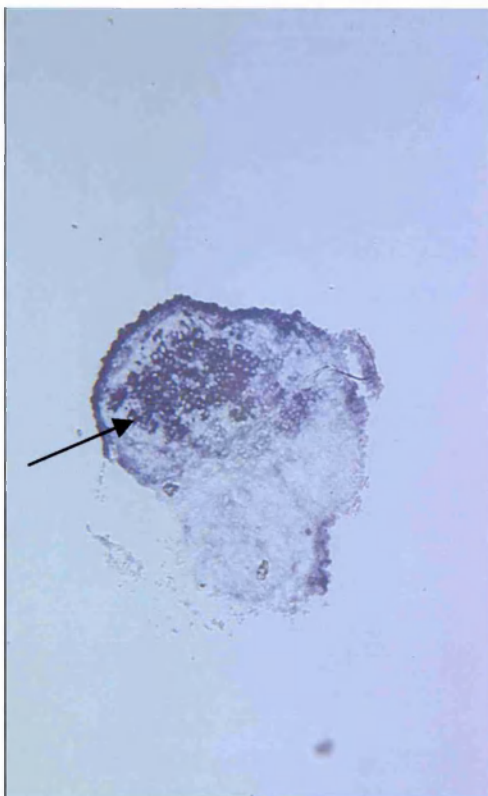

B

Figure 6.15

Figure 6.15 p75NTR staining of gonad cultures

Immunostaining using p75NTR antibody on sections of gonads cultured in the absence and presence of mAb 407. p75NTR was located outside developed cords in control cultures (A, right). Areas where staining was absent corresponded to cords, as demonstrated by adjacent sectioned stained for alkaline phosphatase. Alkaline phosphatase is a marker of germ cells (A and B, left). Absence of staining corresponds to the presence of cords (arrows right A). In gonads cultured in the presence of mAb 407, p75NTR is located around the edges of the gonad. No staining is observed in the centre of the gonad, corresponding to alkaline phosphatase positive cells (B, left).

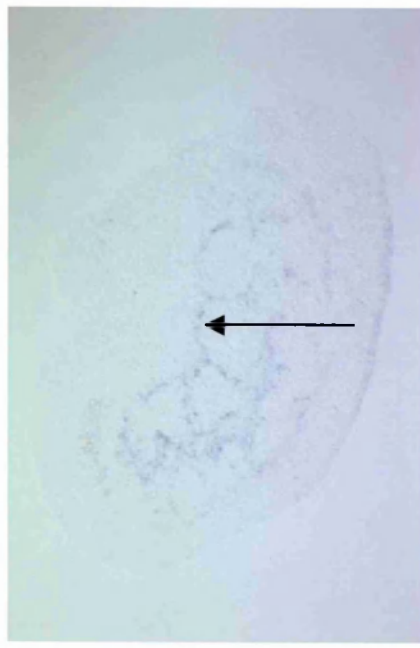
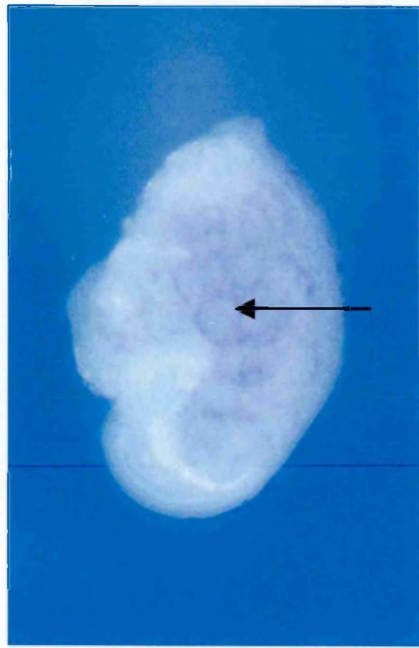

A

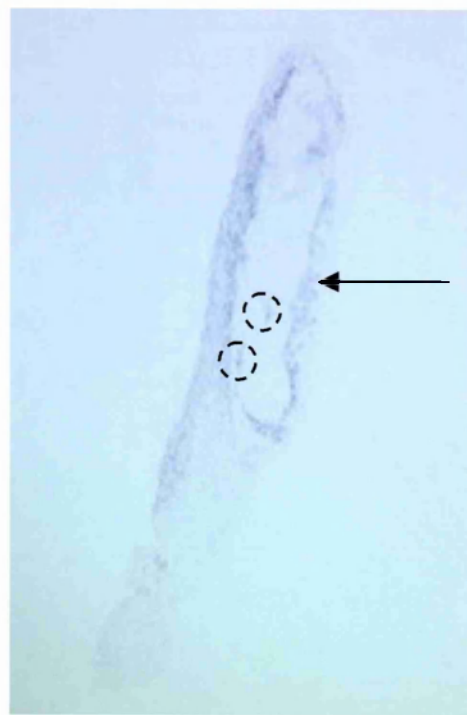

B

Figure 6.16

Figure 6.16 Expression of *Ptc-1* in cultured gonads

Expression of *Ptc-1* was detected in gonads cultured in the absence and presence of mAb 407 using WMISH. Expression in control cultures is concentrated around the outside of the cords, as seen in both wholemounds and sections of whole gonads (arrows A). Expression in gonads cultured in the presence of mAb 407 appears to be concentrated around the edges of the whole gonad. Isolated cells expressing *Ptc-1* can be seen (circles) that may correspond to the location of Leydig cells (B).

Inspection of wholemount explants suggests expression throughout the length of the test gonad, in a similar manner to *Sox9*, and *Oct4*. However, sectioning of these gonads reveals this expression to be concentrated at the edges of the gonad, in a similar manner to the pattern of p75NTR expression. Isolated *Ptc-1* expressing cells can be observed within the body of the gonad, and these may correspond to the presence of Leydig cells (Figure 6.16B).

6.4.9.3 Expression of PECAM in cultured gonads

Another cell type which migrates specifically into the male gonad from the mesonephros is the endothelial cell (Martineau et al., 1997). It has been shown that these cells contribute to the male-specific vasculature of the developing testis (Brennan et al., 2002), namely the prominent coelomic vessel and interstitial vessels.

Platelet endothelial cell adhesion molecule (PECAM) labels endothelial and germ cells and was therefore used here to study the effects of mAb 407 on endothelial cell migration into cultured gonads (Figure 6.17). Firstly, an anti-PECAM-1 monoclonal antibody was used to examine PECAM expression in 13.5 dpc male gonad explants (Figure 6.17A) where it detected two distinct types of positive cell. High levels of expression were associated with the endothelial cells of the coelomic vessel (black arrow in Figure 6.17A) and particular interstitial cells (pink arrow in Figure 6.17A) around the edge of testis cords. The latter presumably derive from endothelial cells of interstitial

blood vessels. Lower levels of expression were detected in germ cells of the testis cords (white arrow in Figure 6.17A). These quantitatively distinct expression types were therefore used as indicators of the presence of endothelial (high) or germ cells (low) in cultured gonads. In gonads cultured in the absence of mAb 407, cells expressing at high levels (black arrow in Figure 6.17C control) and low levels (white arrow in Figure 6.17C control) were observed in the gonad in a pattern similar to 13.5 dpc male explants. In contrast, mAb 407-treated gonads showed almost exclusively low-level expressing cells in the gonad (white arrow in Figure 6.17C), whilst high-level expressing cells were confined to the edge of the gonad in the position of the coelomic vessel (black arrow in Figure 6.17C). These data suggest that endothelial cells are excluded from the main body of the gonad in mAb407-treated male gonads.

6.5 Discussion

When male gonads are explanted into organ culture, subsequent development of testis cords occurs at the same rate as development *in vivo*. Data described in this chapter suggests a role for Vanin-1 in the formation of testis cords. Blocking its function by the addition of a monoclonal antibody to Vanin-1 disrupts this process *in vitro*. A clear trend can be seen in these experiments: addition of mAb 407 disrupts cord formation in the developing

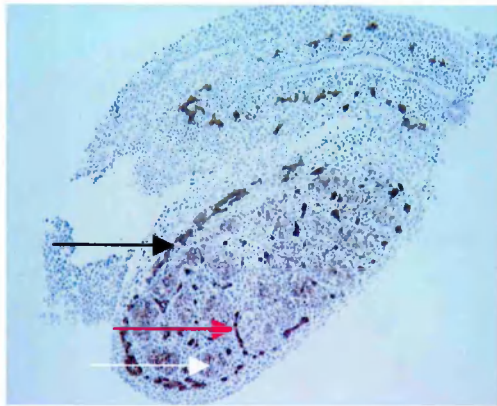

A

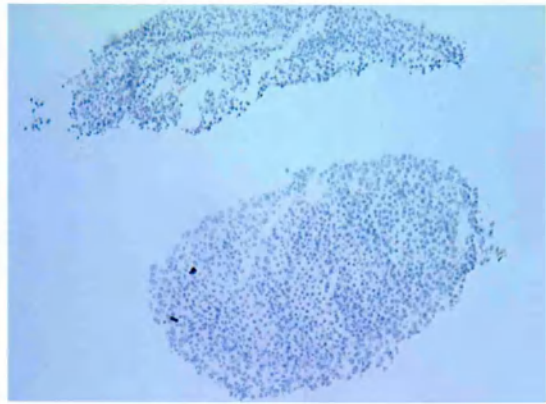

B

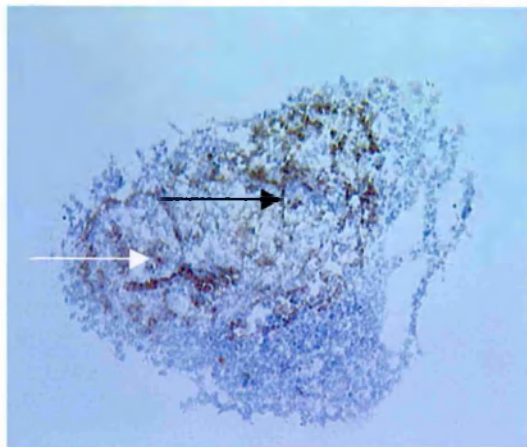

Control

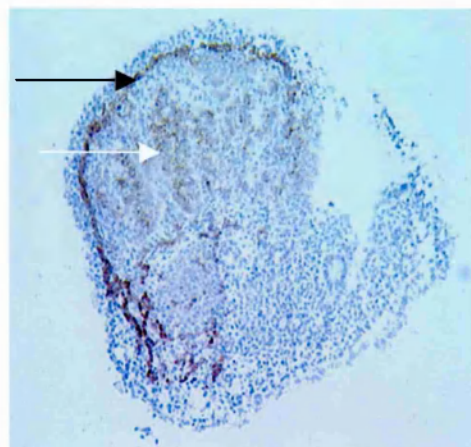

mAb 407

C

Figure 6.17

Figure 6.17 Expression of PECAM-1

Immunostaining results are shown using an antibody to PECAM-1 on sections of 13.5 dpc male gonads and gonads cultured in the absence and presence of mAb 407. PECAM-1 marks both endothelial and germ cells. Stronger staining can be seen in the interstitium of gonads at 13.5 dpc corresponding to endothelial cells of the coelomic vessel and interstitium (A black and pink arrows respectively), whereas weaker expression is seen in the testis cords corresponding to germ cells (A white arrow). No staining is seen in gonads treated with secondary antibody alone (B). In gonads cultured without mAb 407 endothelial (black arrow) and germ cell immunostaining (white arrow) can be seen in the gonad (C). In gonads cultured in the presence of mAb 407 the weaker germ cell staining can be observed in the gonad (white arrow) whereas the stronger endothelial staining is restricted to the edges (black arrow) (C).

male gonad, with only occasional instances in which cords form successfully in the presence of antibody or fail to form in untreated controls. Previous studies have demonstrated similar sliding scales of success in cord formation in culture, depending on the precise age of the gonad (Tilman and Capel, 1999b).

The patterns of various testicular cell markers show a distinct alteration in test cultures. The two markers of cord cell types, *Sox9* (a Sertoli cell marker) and *Oct4* (a primordial germ cell marker), are expressed throughout the gonad and no cord-like pattern is observed. In contrast, two markers of migratory peritubular myoid cells, which are normally located in between the cords, are limited to the outer edge of the gonad, and do not migrate into the centre of the gonad. Additionally, analysis of the endothelial cell marker

PECAM suggests that endothelial cells are also limited to the edges of mAb 407-treated gonads.

As mentioned earlier, two possible functions of Vanin-1 in the development of the testis come into focus in the context of Vanin-1's expression profile and protein function:

- 1- It could be involved in the migration of cells from the mesonephros into the gonad, a process required for testis cord formation.
- 2- It could be involved in the post-migrational organisation of cells into testis cords.

The data presented here appear to support the first of these hypotheses. Male-specific cell-types that have their origin in the mesonephros are not found in the body of the gonad in samples that are cultured in the presence of mAb 407. However, it remains a possibility that such cells have been actively excluded *after* successful migration: it would be necessary to test cultured gonads at a variety of time-points to exclude this possibility.

A direct assay for defects in migration from the mesonephros caused by blocking Vanin-1 *in vitro* has already been performed. At a meeting in 2002, it was reported that anti-Vanin-1 mAb 407 can inhibit cell migration from the mesonephros into the male gonad (Koopman et al., 2002). In these unpublished experiments, mAb 407 was added to co-cultures of GFP-expressing mesonephroi and wild-type gonads. GFP-positive cells were excluded from the gonads in these cultures, in contrast to controls. The data presented in this chapter can be seen to support these independent observations. Markers of PMCs and endothelial cells suggest that, whilst precursors of these cell-types migrate from the mesonephros, they tend to remain on the gonadal surface, beneath the coelomic epithelium, rather than entering the central body of the gonad.

It is worth pointing out that none of the markers used to identify these migratory cell-types is perfect, and some interpretation is required to support these conclusions.

6.6 Summary

- When mAb 407 is added to male gonads in culture they fail to develop testis cords, in contrast to control cultures which develop them at the same rate as *in vivo*.
- These cultures are positive for various markers of testicular development but no organisation of cells into testis cords has occurred. They develop as cord-free testes.
- Markers of migratory PMCs and endothelial cells are also present, although only at the surface of the gonads: cells do not seem to penetrate the body of the gonad.
- These data seem to suggest that some form of defective mesonephric cell migration is the basis of the cord-free testis development in mAb 407-treated XY gonads.

**Chapter 7: Analysis of gonadal development
in embryos lacking Vanin-1**

7.1 Introduction

The previous chapter demonstrated how the blocking of Vanin-1 function using mAb 407 disrupts testis cord formation *in vitro*. Results suggest that cords fail to develop, either by the inhibition of cell migration from the mesonephros into the gonad, or by the inability of cells to organise and associate with one another to form testis cords.

In order to determine the physiological role of Vanin-1 *in vivo* it is necessary to examine mice lacking the protein. Mice homozygous for a null allele of *Vanin-1* (*Vanin-1* ^{-/-} mice or *Vanin-1* null mice) were generated in the laboratory of Philippe Naquet (Pitari et al., 2000).

Briefly, the first exon containing the ATG initiation codon and 2 kb of 5' upstream promoter sequence was replaced by the neomycin gene, oppositely oriented thus preventing *Vanin-1* transcription (Figure 7.1). This results in the generation of a 4.3kb fragment after *Hind111* digestion and a longer PCR fragment (Pitari et al., 2000).

Pitari et al. demonstrated that there was a complete absence of *Vanin-1* transcription and protein production in the kidney, where it is normally expressed. This was confirmed by Northern blot, RT-PCR and Western blot analysis. Furthermore, *Vanin-1* is not expressed in the gonads of *Vanin-1* ^{-/-} homozygotes at 13.5 dpc (Figure 7.2).

From their initial analysis they concluded that this *Vanin-1* null mouse has no major general or lymphoid developmental defects under physiological

conditions. However, they did conclude that these mice lack a pantetheinase function. Pantetheinase is a membrane-bound enzyme which catalyses the hydrolysis of D-pantetheine to produce cysteamine and pantothenic acid *in vitro*. Pantetheinase activity is found in many tissues, however, its biological role has not been studied *in vivo*. Pitari et al reported that *Vanin-1*-deficient mice lack pantetheinase activity in the kidney and liver. Consequently, these mice also lack free cysteamine, which is a powerful anti-oxidant. The putative function of Vanin-1 was discovered in the context of thymic reconstitution following sub-lethal irradiation, which generates free radicals. Because the null mouse has no major immune defects under normal condition, the importance of Vanin-1 might only be revealed under stress, for example, irradiation, oxidative or inflammatory stress.

As mentioned previously, cysteamine is a powerful anti-oxidant; and is a key regulator of essential metabolic pathways. However, the physiological importance of cysteamine is still not understood. One enzyme, γ -glutamylcysteine synthase (γ -GCS), catalyses the key step in glutathione (GSH) synthesis. This enzyme plays a role in protecting cellular components from toxic species.

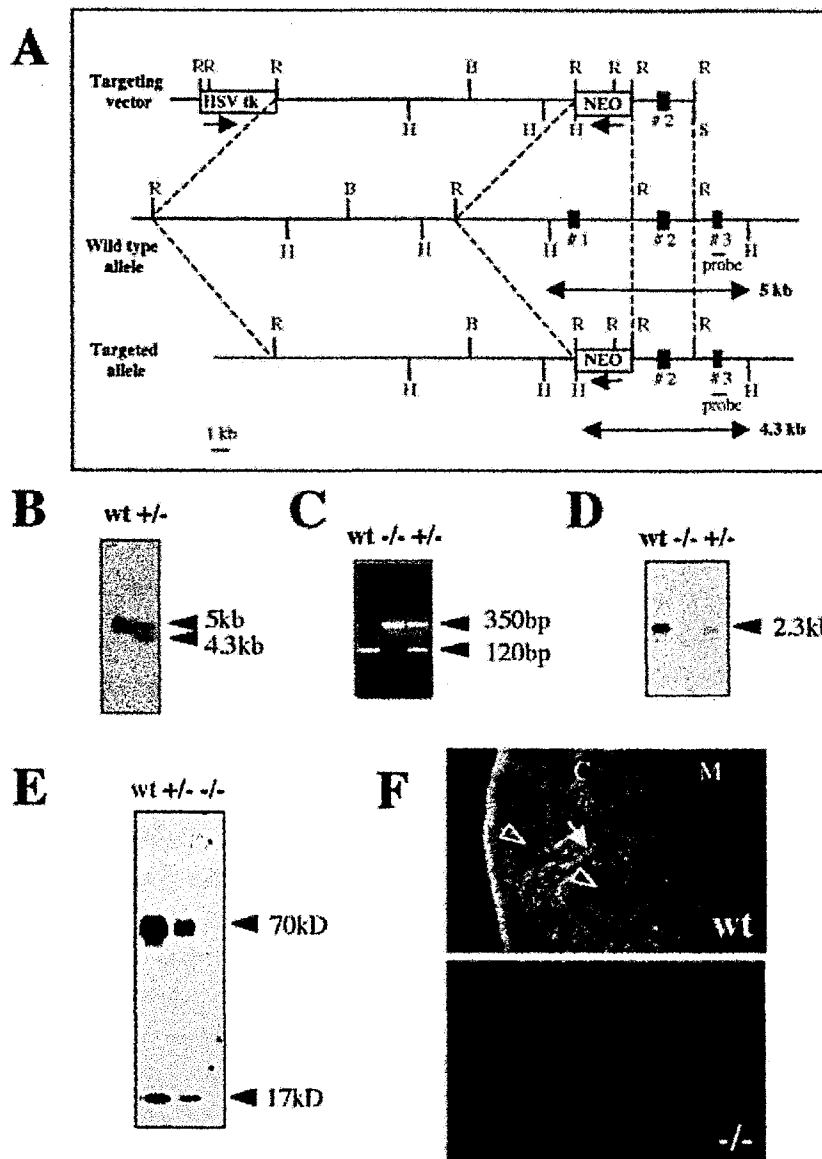

Figure 7.1 Generation of *Vanin-1*-deficient mice

A: Map of the construct used for the homologous recombination in ES cells. Arrows indicate the transcriptional orientation of the neomycin and HSV-tk genes. Double-head arrows indicated the size of the restriction fragments obtained by Southern blot analysis on a *Hind*III digest of genomic DNA from wild type or targeted alleles. The position of the 3' probe is underlined. The result of the recombination event was checked by Southern blot (B), PCR (C) and Northern blot on kidney RNA (D). The *Vanin-1* gene deficiency was confirmed by the loss of the Vanin-1 protein in kidney visualized by Western blot (E) or immunohistochemistry (F). C: cortex; M: medulla; the arrow indicates a Vanin-1-positive cortical tubule whereas arrow-heads show Vanin-1 negative glomerul. From Pitari et al. (2000).

Vanin-1 null mice lack free cysteamine and have subsequently been shown to exhibit an improved response to intestinal inflammation (Martin et al., 2004). Null mice were tested for their response to acute and chronic infection, and in both cases *Vanin-1* *-/-* mice controlled the inflammatory response better than controls. When *-/-* mice were subjected to intestinal injury they exhibited a greatly reduced number of intestinal haemorrhages compared to wild-types. In addition, transcripts associated with inflammatory cell activation were barely expressed compared to wild type mice. Higher GSH levels were found in *Vanin-1* *-/-* mice compared to wild-types; this corresponded to an increased γ -GCS synthesis in the liver and intestine. *In vitro* studies show that cysteamine down-regulates γ -GCS activity. The investigations of Martin et al (Martin et al., 2004) give similar results *in vivo*. Undetectable pantetheinase activity and cysteamine levels in *Vanin-1* *-/-* mice are associated with higher γ -GCS activity in the liver; furthermore, administration of cysteamine reduced enzyme activity to wild-type amounts. One cysteamine function is to up-regulate inflammation. Therefore *Vanin-1* can be classed as a regulator of intestinal inflammation, via its regulation of cysteamine release.

P.Naquet et al observed no changes in the sex ratio or fertility of the *Vanin-1* null mouse, two indicators of major defects in gonad development.

7.2 Aim of this chapter

The first aim of this chapter is to study testis development in the *Vanin-1* $-/-$ mouse, by comparing morphology and gene expression in *Vanin-1*-deficient and wild-type gonads at 13.5 dpc. This stage was chosen because testis cords have developed a highly regular structure at this point and it is only approximately 30 hours after the onset of *Vanin-1* expression.

Another aim of this chapter is to study the effects of *in vitro* culture on gonads explanted from the *Vanin-1* null mouse, for two reasons. Firstly, because *Vanin-1* was discovered in the context of thymic reconstitution following sub lethal irradiation, it can be concluded that its importance might be revealed under stress conditions. The general effect of the stress of culture was examined to see if male gonads from the null mouse could form testis cords under culture conditions. Secondly, in order to test the specificity of mAb 407, it was added to cultures of XY *Vanin-1* null gonads in order to determine whether testis cord formation is affected. If no effect is seen, it can be concluded that the effect of the antibody is mediated specifically by its effect on *Vanin-1*.

Another member of the *Vanin* family, *Vanin-3*, exists in the mouse. The role of this molecule in possible compensation for loss of *Vanin-1* activity was also studied.

The effect of the genetic background on testis development can be important (Albrecht et al., 2000) and therefore the effects of changing the background

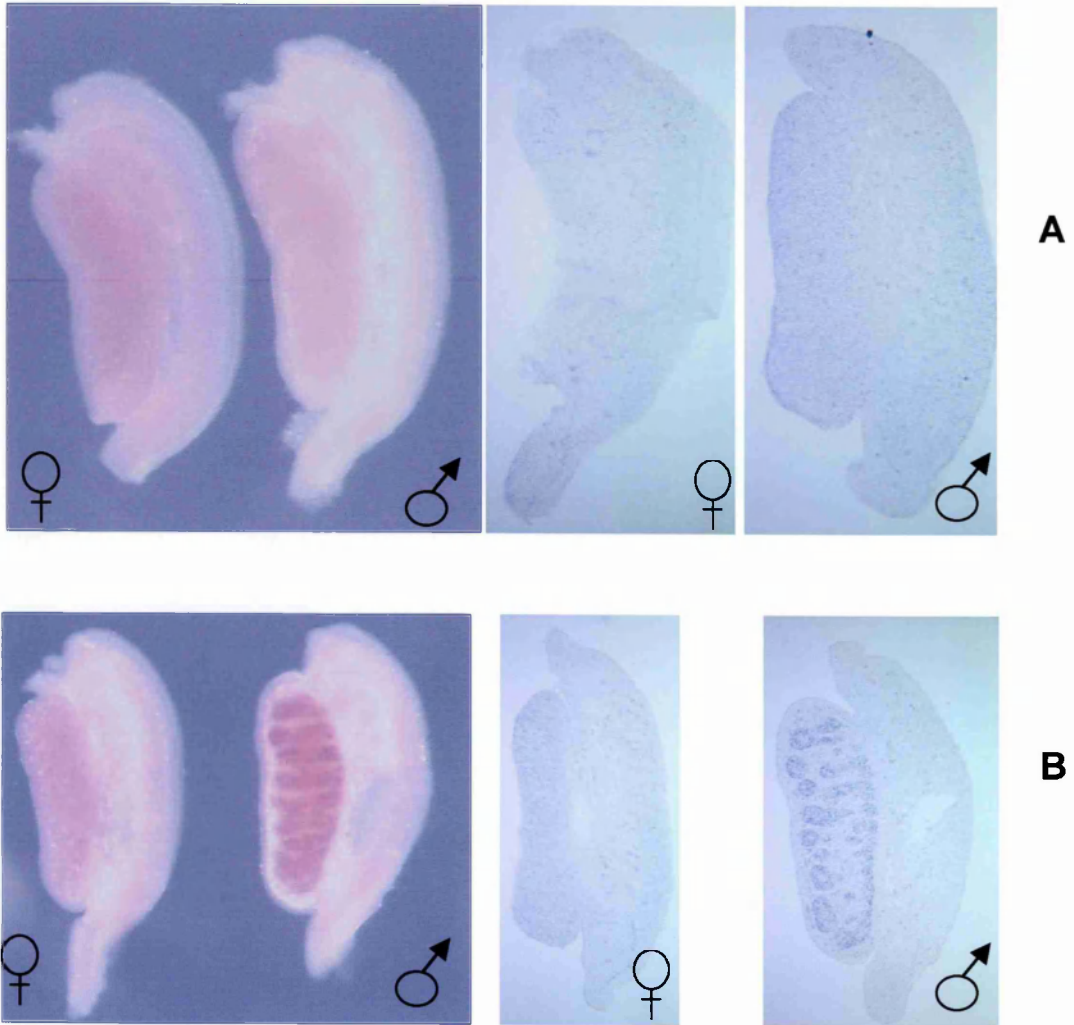

Figure 7.2

Figure 7.2 No *Vanin-1* expression is observed in *Vanin-1*^{-/-} gonads at 13.5 dpc

WMISH was performed on gonads homozygous for a null allele of *Vanin-1* and wild-type BALB/c gonads. No *Vanin-1* transcripts are observed in male and female gonads of *Vanin-1*^{-/-} mice at 13.5 dpc. Longitudinal sections confirmed this lack of expression (A). Wild-type (BALB/c) gonads exhibit expression in the testis cords. Longitudinal sectioning of these gonads revealed that this expression is located at the periphery of each cord, in the region of the Sertoli cells (B).

of the homozygous mutants from BALB/c to C3H/HeH has been investigated.

7.3 Strategy

- WMISH was used to compare the expression of various testicular cell markers between *Vanin-1* null and BALB/c mice. *Vanin-1* *-/-* mice are kept as a homozygous colony on a BALB/c background, and hence a separate colony of wild-type mice was needed for all comparisons.
- 11.5 dpc male gonads from the *Vanin-1* null were placed into culture in the presence and absence of mAb 407 to observe their development *in vitro*. The expression of testicular markers was examined in these cultures.
- The expression of *Vanin-3* in wild-type and null mice was studied by WMISH and RT-PCR.
- The *Vanin-1* null mutation was back-crossed onto the C3H/HeH background for 5 generations. At this stage, inter-crosses were performed in order to generate homozygous mutants.

7.4 Results

7.4.1 WMISH studies

Various testicular cell markers were used to compare gonads from male *Vanin-1* *-/-* and BALB/c mice at 13.5 dpc. The Leydig cell markers *3 β HSD* and P450 Side Chain Cleavage enzyme (*Scc*) (Rouiller et al., 1990) both

exhibit a pattern in *-/-* embryonic gonads comparable to that seen in wild-type BALB/c mice (Figure 7.3 A, B) although expression can be seen to be slightly less intense in the BALB/c mice. This can also be observed in younger wild-type and *-/-* gonads at approximately 13.0 dpc (Figure 7.4 A, B). This difference in intensity is likely to be due to the slight difference in developmental stage that exists between the *Vanin-1 -/-* and wild-type gonads.

The hedgehog receptor Patched-1(*Ptc-1*), a marker of peritubular myoid cells (PMCs) and Leydig cells also exhibits a pattern that is essentially the same as that seen in BALB/c wild-type embryos, but with a slightly lower intensity (Figure 7.3, A, B, Figure 7.4 A, B). Longitudinal sections also reveal this expression pattern (Figure 7.5) at 13.5 dpc. p75NTR, another potential marker of PMCs, again showed expression that is slightly more intense compared to BALB/c gonads at 13.5 dpc (Figure 7.6).

To see if this differing expression intensity for several markers is reflected in other genes in the same pathway as *Ptc-1*, expression of Desert Hedgehog (*Dhh*) was investigated. *Dhh* is the ligand of *Ptc-1* and is expressed in the Sertoli cells from 11.5dpc onwards (Bitgood et al., 1996). *Dhh* expression can be seen to be comparable in pattern and intensity between BALB/c and *Vanin-1 -/-* gonads at 13.5 dpc (Figure 7.7).

BALB/c

Vanin-1 ^{-/-}

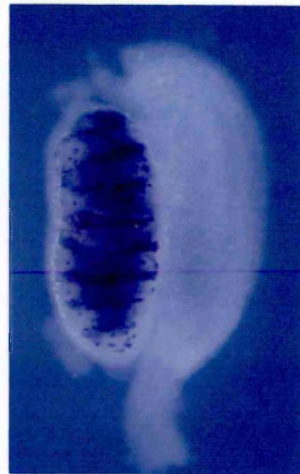

A



B



C

Figure 7.3

Figure 7.3 Interstitial marker analysis in *Vanin-1* ^{-/-} and ^{+/+} embryonic male gonads

WMISH analysis of various interstitial cell markers on *Vanin-1*^{-/-} gonads and wild-type BALB/c gonads at 13.5 dpc are shown. *3βhsd* a marker of Leydig cells shows a similar expression pattern to wild-type male gonads, though with slightly less intensity with expression confined to cells of the interstitium (A). This is also seen with another Leydig cell marker *Scx* (B) and *Ptc-1*, a marker of PMCs and Leydig cells (C).

BALB/c

***Vanin-1* ^{-/-}**



A

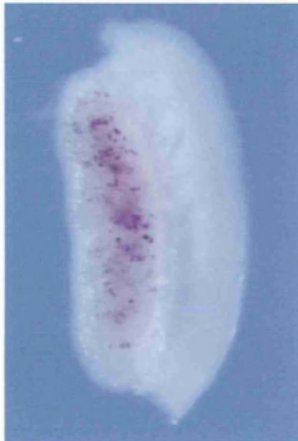

B



C

Figure 7.4

Figure 7.4 Expression of interstitial cell markers at 13.0 dpc

WMISH analyses of interstitial cell markers on *Vanin-1*^{-/-} and wild-type BALB/c male gonads at 13.0 dpc are shown. Expression of *3βhsd* (A), *Scx* (B) and *Ptc-1* (C) at 13.0 dpc also reveals a comparable expression pattern which is slightly less intense in wild-type gonads.

BALB/c

***Vanin-1* ^{-/-}**

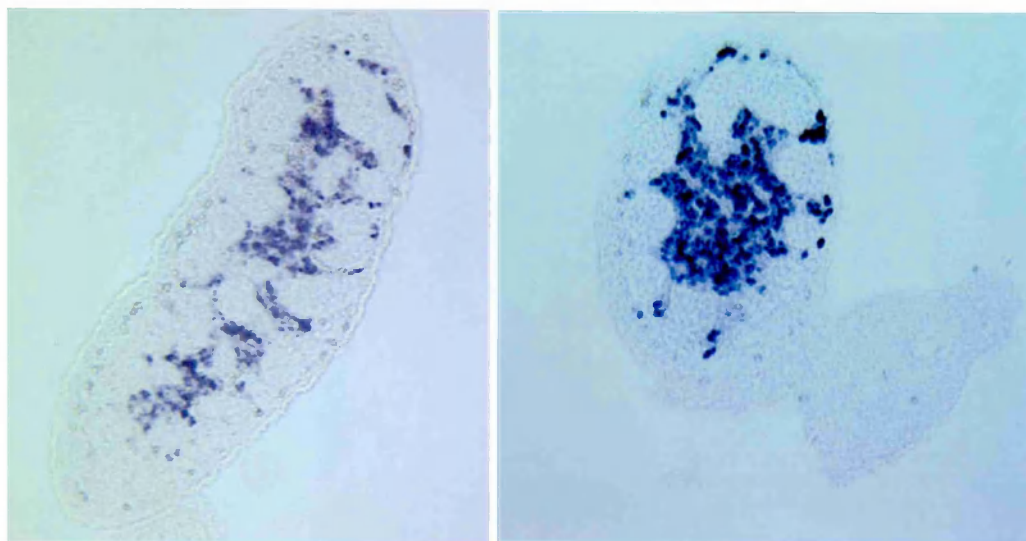

A

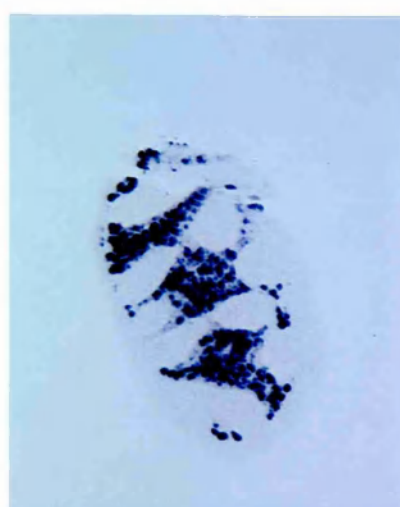
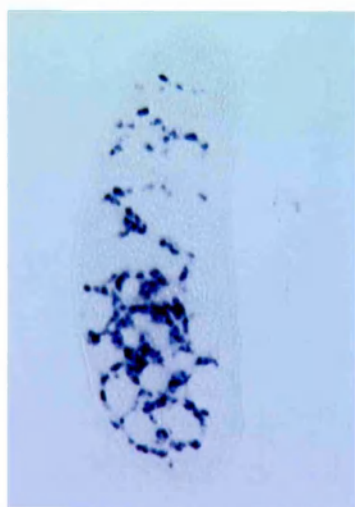

B

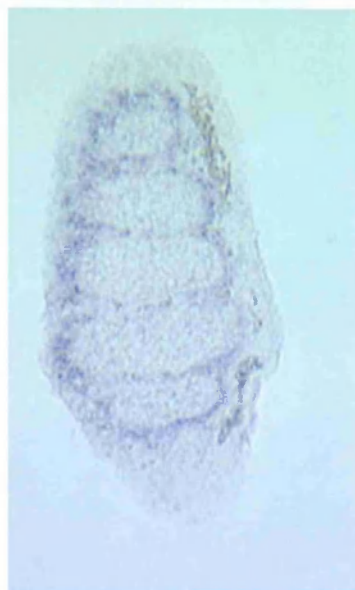

C

Figure 7.5

Figure 7.5 longitudinal sections of gonads stained for interstitial cell markers after WMISH

Longitudinal sections of male gonads at 13.5 dpc stained for interstitial cell markers are shown. Expression of *3βhsd* (A), *Scc* (B) and *Ptc-1*(C) in sections confirms the WMISH data. *3βhsd* and *Scc* exhibit similar expression patterns with transcripts located in the Leydig cells. *Ptc-1* expression is more extensive and is located in both Leydig and peritubular myoid cells.

BALB/c

***Vanin-1* ^{-/-}**

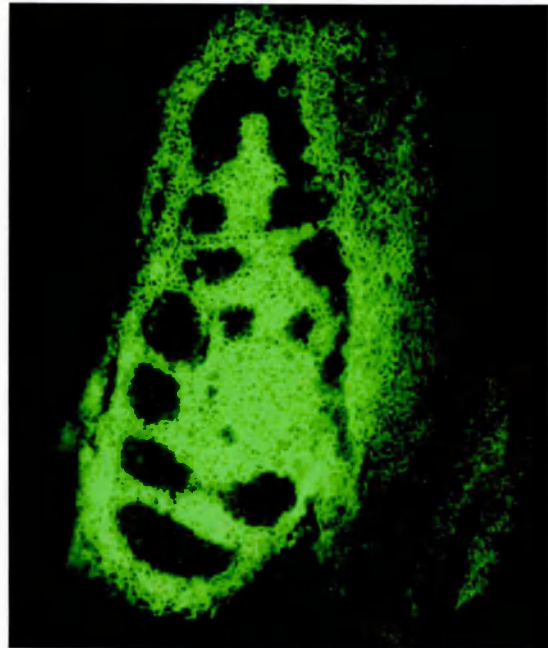
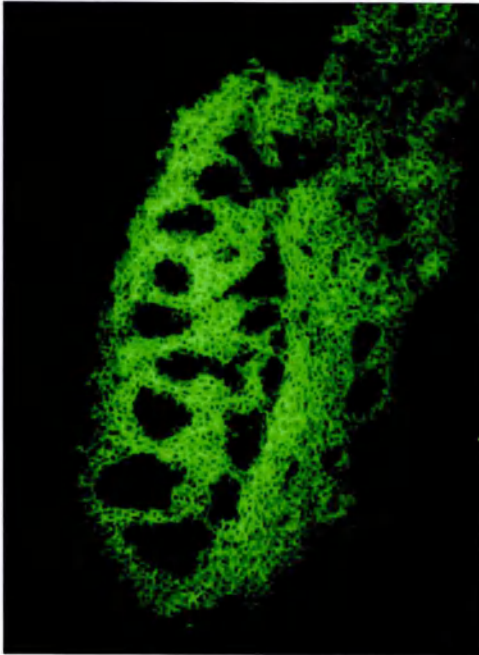

Figure 7.6

Figure 7.6 p75NTR expression in sections of *Vanin-1* ^{-/-} and BALB/c male gonads

Immunostaining of cryosections using an antibody to p75NTR are shown. Sections used were *Vanin-1*^{-/-} and BALB/c gonads at 13.5 dpc. Expression of p75NTR between BALB/c and *Vanin-1*^{-/-} gonads is very similar. Protein is located in the interstitium in both mouse strains, with a slightly higher intensity in the *Vanin-1*^{-/-} mice.

BALB/c

***Vanin-1* ^{-/-}**



Figure 7.7

Figure 7.7 Expression of *Dhh* in male gonads at 13.5 dpc

WMISH analysis of the Sertoli cell marker *Dhh* was performed on *Vanin-1*^{-/-} and BALB/c gonads at 13.5 dpc. There is no discernable difference in expression of *Dhh* between BALB/c and *Vanin-1*^{-/-} mice. Transcripts are located in the testis cords of both mouse strains. Longitudinal sections (lower panels) reveal this expression to be found towards the periphery of the cords.

BALB/c

***Vanin-1* ^{-/-}**

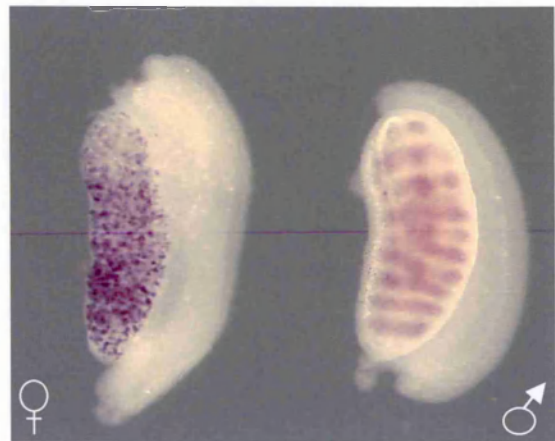
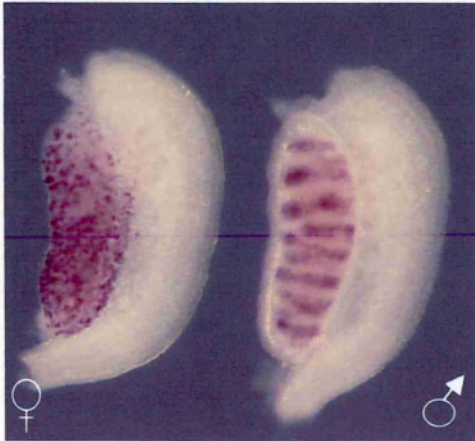

A



B

Figure 7.8

Figure 7.8 Expression of *Oct4* and *Sox9* in male and female gonads at 13.5 dpc

WMISH analyses of two cell markers, the Sertoli cell marker *Sox9* and *Oct4*, a marker of primordial germ cells are shown. Analysis was performed on male and female gonads at 13.5 dpc.

(A) No differences were observed in *Oct4* expression. Transcripts were located throughout the length of the ovary in both strains of mice in a typically punctuate pattern, whereas in the male, expression was found within the testis cords.

(B) Expression of *Sox9* in gonads at 13.5 dpc is located in the testis cords of male gonads and is absent from female gonads. This expression is the same in both *Vanin-1*^{-/-} and BALB/c mice.

BALB/c

***Vanin-1* ^{-/-}**

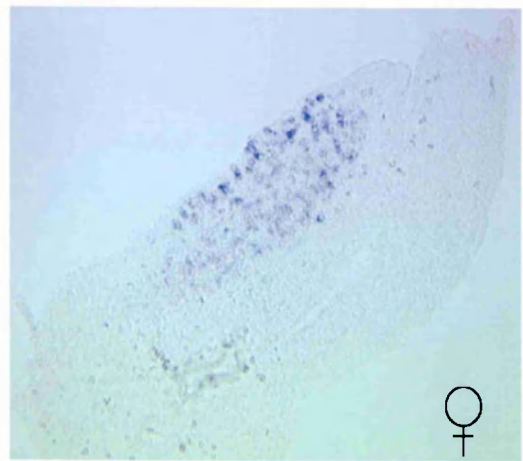
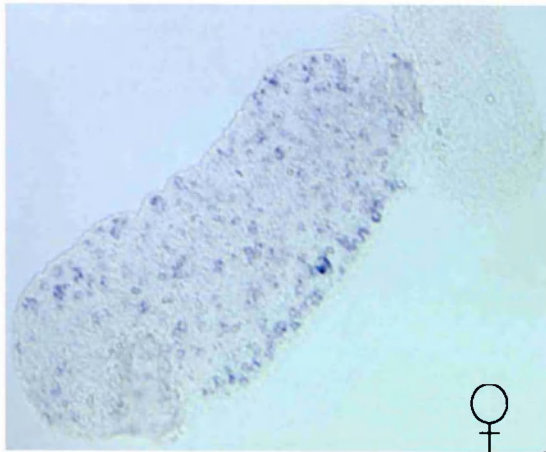

♀

♀

A

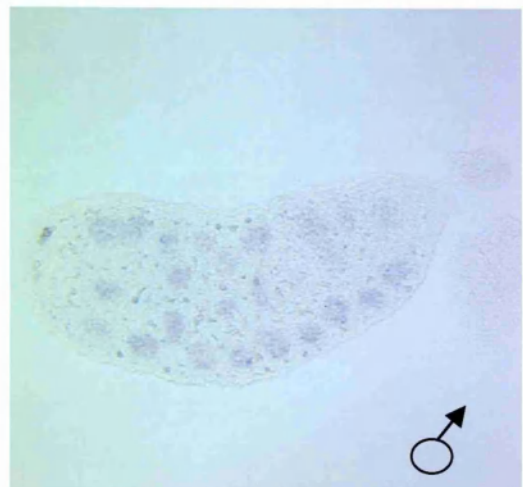
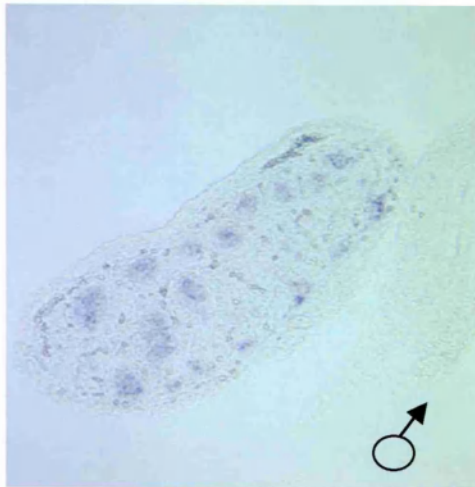

♂

♂

B

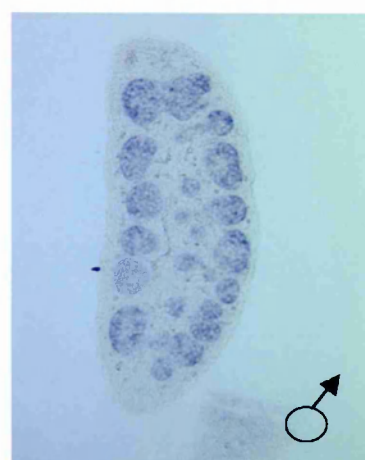

♂

♂

C

Figure 7.9

Figure 7.9 Longitudinal sections of gonads analysed for expression of Oct4 and Sox9 by WMISH

Longitudinal sections of gonads analysed for expression of *Oct4* and *Sox9* by WMISH are shown. These sections confirm that there are no differences in expression pattern or intensity between BALB/c and *Vanin-1*^{-/-} mice.

(A) Expression of *Oct4* in the ovary is seen throughout its length, corresponding to the location of germ cells within it, with both mouse strains exhibiting a similar expression pattern.

(B) Expression of *Oct4* in male gonads is also located in germ cells; these are found within the testis cords. A similar expression pattern is seen between these mice as revealed by longitudinal sectioning of the gonads after WMISH.

(C) Expression of the Sertoli cell marker *Sox9* is found around the periphery of the testis cords in both mouse strains.

Two other markers, *Oct4* (germ cell) and *Sox9* (Sertoli cell), also exhibit expression patterns essentially identical between these two mouse strains (Figure 7.8, Figure 7.9).

7.4.2 Organ culture studies

7.4.2.1 Effects of culture on cord formation

Male gonads were explanted at 11.5 dpc from *Vanin-1* *-/-* and BALB/c embryos and placed into culture. To discount any variation in culture conditions between dishes, each dish was set up containing both strains in a clear pattern, for example:

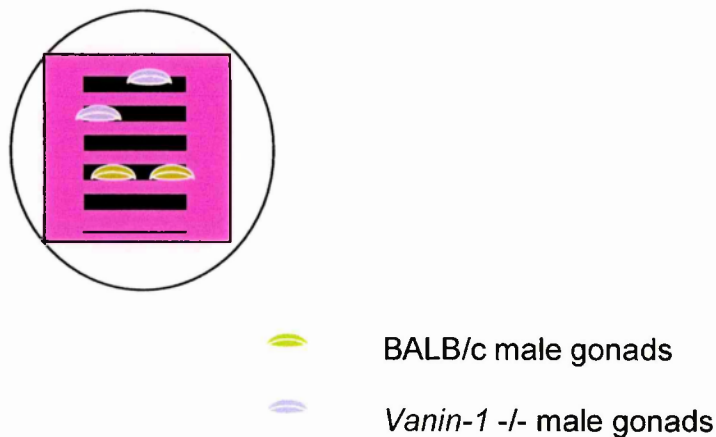

Figure 7.10 layout of gonads placed in culture

Figure 7.10 shows a schematic diagram of an example of how gonads were explanted in a specific pattern to distinguish them in culture. This pattern was noted and cultures were incubated for 48 hours. 1.5% agar block cultured in DMEM/10% FCS/50 μ gml⁻¹ ampicillin.

Culture medium was changed after 24 hours and the culture terminated after 48 hours. Visual scoring was performed as described in section 6.4.4. In total, 17 gonads from the *Vanin-1* *-/-* mouse and 11 BALB/c gonads were put into culture. Data obtained suggest that neither strain forms cords with the same success rate as gonads from 3H1 embryos. Typically, approximately 80% of 3H1 male gonads would form cords when cultured, whereas 5/11 (45%) BALB/c and 4/17 (23%) *Vanin-1* *-/-* gonads fully formed testis cords (Figure 7.11).

Fisher's exact test was used to compare the data from the two strains (Fisher, 1934). To test for a significant difference in their ability to form testis cords *in vitro*. Results revealed no significant difference between them (chi-square = 2.84, df=2 exact P= 0.30). Hence, *Vanin-1* *-/-* gonads form cords *in vitro* at the same efficiency as BALB/c gonads.

7.4.2.2 Effect of mAb 407 on cord formation

Cultures were also set up in the presence and absence of mAb407 to test its specificity. Dishes were assembled as described in section 7.4.2.1. In this case, each UGR was dissected into two and one gonad mesonephros pair was placed in a dish containing mAb407 and the other into a dish without, as described in Chapter 6. Culture medium was changed after 24 hours and the culture stopped after a further 24 hours with visual scoring for cord

formation performed as before. Cultures were also preserved for WMISH analysis.

As expected mAb 407 was able to block cord formation in the BALB/c gonad explants though overall cord formation was not as successful as when performed using 3H1 gonads. Fisher's exact test was used to compare results, chi-square was calculated as 11.59 (df =2 exact P= 0.0020). However, no effect was observed with the *Vanin-1* *-/-* cultures, chi-square was calculated as 1.89 (df=2 exact P=0.41) (Figure 7.12).

Analysis of the testicular cell marker *Ptc-1* was used in order to study these cultured gonads further. *Ptc-1* is a marker of peritubular myoid and Leydig cells, located in the interstitium of male gonads. Expression analysis by WMISH reveals a similar pattern between mAb 407-treated and untreated cultures of *Vanin-1* *-/-* gonads, with *Ptc-1* transcripts detected in the interstitium of both (Figure 7.13A). A distinct difference is observed between BALB/c gonads which have been cultured in the absence and presence of mAb 407. No testis cords form in the presence of mAb 407; this is reflected in the expression of *Ptc-1* which is restricted to the periphery of the gonad. In gonads cultured without mAb 407, *Ptc-1* expression is located in the interstitium of the gonad (Figure 7.13B).

7.4.3 *Vanin-3* expression studies

Initial studies have demonstrated that the *Vanin-1* *-/-* mouse exhibits no immune or testis defects. Another member of the *Vanin* gene family, *Vanin-3*, also exists in the mouse and is expressed in the adult liver (Granjeaud et al., 1999). *Vanin-3* also encodes a pantetheinase enzyme, though unlike *Vanin-1* it is a secreted protein. Therefore, any possible compensation for loss of *Vanin-1* activity by *Vanin-3* was investigated. For *Vanin-3* to be compensating for this loss it must show expression in the same tissues as *Vanin-1*. Therefore, *Vanin-3* expression was examined in developing gonads. RT-PCR was performed using primers which had been used to clone the full length *Vanin-3* cDNA (Granjeaud et al., 1999). A transcript of approximately 1.8kb was detected in adult liver RNA, as expected. However, no transcripts were detected in male gonads at 13.5 dpc in either BALB/c or *Vanin-1* *-/-* animals (Figure 7.14A). These primers were also used to clone *Vanin-3* to allow production of a riboprobe. WMISH was then performed on BALB/c and *Vanin-1* *-/-* male gonads at 13.5 dpc. No expression was observed in either (Figure 7.14B).

7.4.4 Backcross of mutant allele to mouse strain C3H/HeH

To assess any effects of changing the genetic background of the *Vanin-1* null mutation it was back-crossed onto mouse strain C3H/HeH.

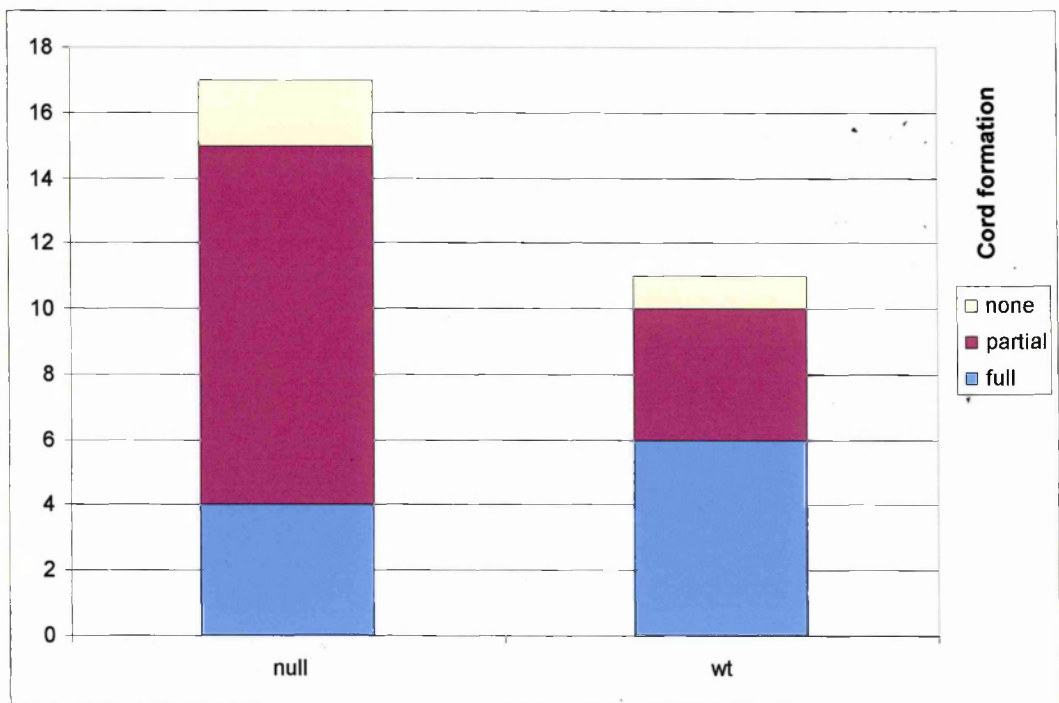

Figure 7.11

Figure 7.11 Effects of culture on cord formation of *Vanin-1* ^{-/-} and BALB/c gonads

Figure 7.11 shows a bar chart of the numbers of *Vanin-1*^{-/-} and BALB/c XY gonads placed in culture at 11.5 dpc, and their resulting cord formation scores after 48 hours. 4/17 *Vanin-1*^{-/-} and 5/11 BALB/c gonads formed testis cords *in vitro*.

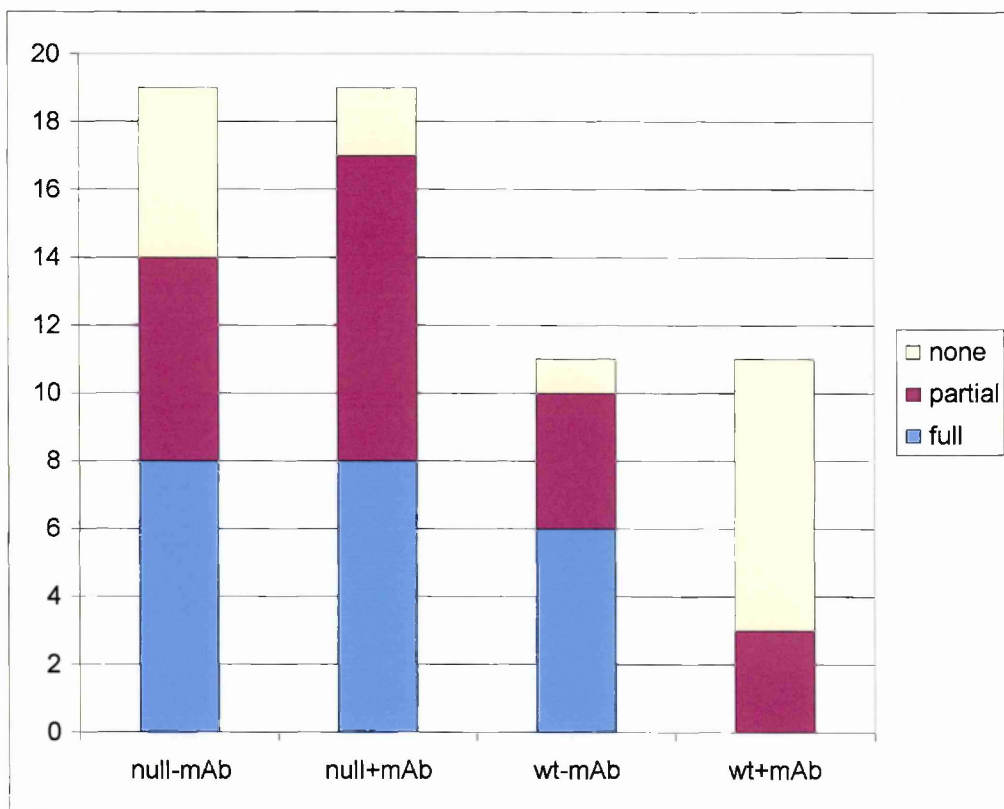

Figure 7.12

Figure 7.12 Effects of mAb 407 on cord formation in *Vanin-1*^{-/-} embryonic gonads *in vitro*.

Figure 7.12 shows a bar chart of the results of placing gonads at 11.5 dpc from *Vanin-1*^{-/-} and BALB/c mice in culture in the absence and presence of mAb407. mAb 407 had no effect on the ability of *Vanin-1*^{-/-} mice to form cords *in vitro*, whereas no cords formed in cultures of BALB/c where this antibody was added. Gonads were cultured for 48 hours.

No mAb 407

mAb 407 added

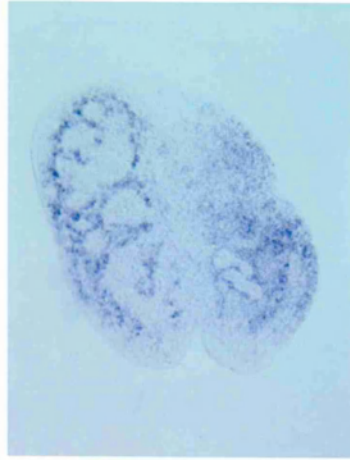
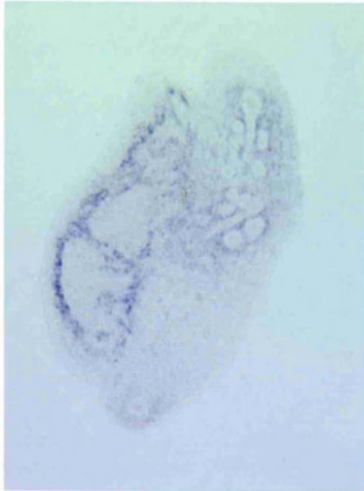

A

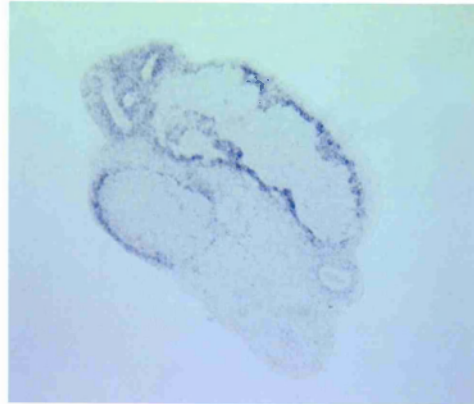
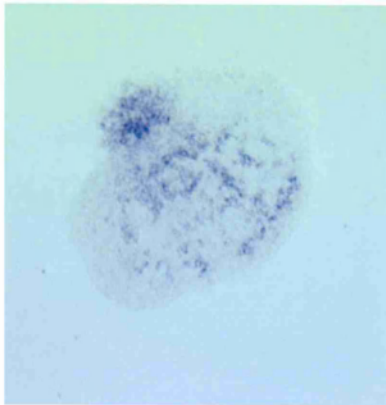

B

Figure 7.13

Figure 7.13 Expression of *Ptc-1* in cultured male gonads

Expression of the peritubular myoid and Leydig cell marker *Ptc-1* was analysed by WMISH in *Vanin-1*^{-/-} and BALB/c gonads cultured in the absence and presence of mAb 407. No difference in expression pattern can be observed between *Vanin-1*^{-/-} gonads cultured in the presence or absence of mAb 407. Both strains formed testis cords. Transcripts were detected inbetween the cords in the region of peritubular myoid and Leydig cells (A).

A distinct difference is seen in BALB/c gonads cultured in the presence of mAb 407. Transcripts can be detected around cords formed in the absence of mAb 407 whereas expression is confined mainly to the edge of the gonad when cultured in the presence of the antibody (B).

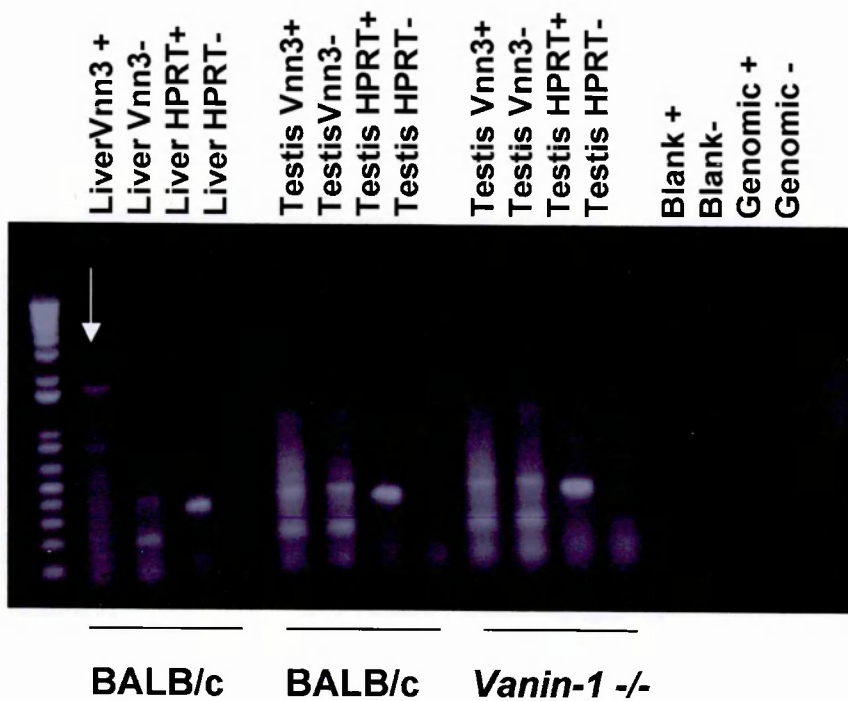

A

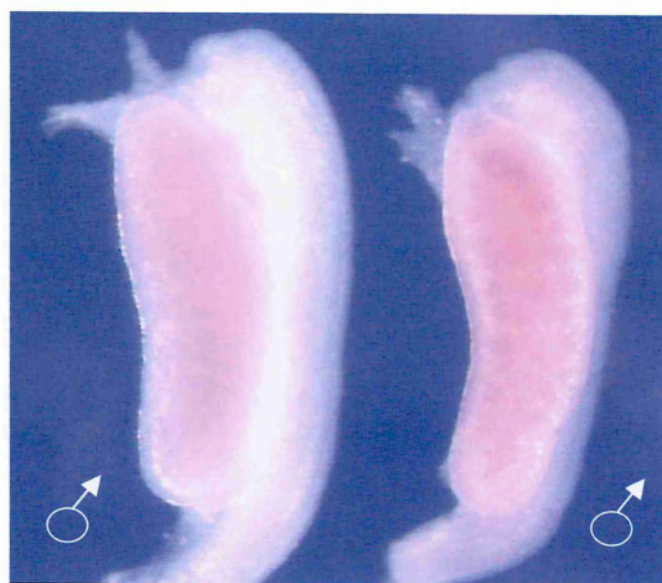

B

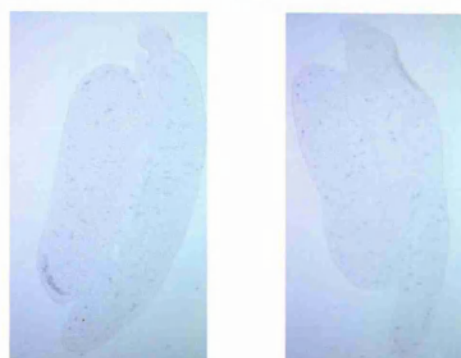

Figure 7.14

Figure 7.14 *Vanin-3* expression studies

Expression analysis of *Vanin-3* in gonads at 13.5 dpc was performed by RT-PCR and WMISH. RT-PCR produced a band of 1.8 kb detected as expected in adult liver (Arrow, A). No transcripts were observed in male gonads of BALB/c or *Vanin-1* *-/-* mice at 13.5 dpc. HPRT expression was used as a positive control for the RT-PCR; a product of approximately 350bp was seen in all tissues (A). No expression of either gene was observed in blank or genomic controls.

WMISH analysis showed no transcripts of *Vanin-3* were detected in BALB/c or *Vanin-1* *-/-* male gonads at 13.5 dpc. This was confirmed by longitudinal sectioning of these gonads (lower panel) (B).

The *Vanin-1* null mutation was obtained in the form of a homozygous stock on a BALB/c background. After crossing mutant homozygotes to wild-type C3H/HeH, male mice heterozygous for the null allele were crossed with female C3H/HeH mice for another four generations. At this point less than 5% of the genome will be BALB/c DNA derived. After the fifth generation of backcrossing heterozygous animals were inter-crossed to obtain homozygous animals along with heterozygous and wild type littermates.

Firstly, litters were dissected at 13.5 dpc when testis cords have normally fully formed to observe any changes to their development. Genotyping was performed by PCR (Pitari et al., 2000). Three litters were obtained with 21 embryos in total. Of these 6 were genotyped as *Vanin-1* *-/-* and were all female. As yet no males have been isolated at 13.5 dpc. Adult animals were also generated by such inter-crosses. In total, 23 female and 16 male inter-cross mice were genotyped and 5 *Vanin-1* *-/-* males were identified, with no obvious testicular abnormalities (see appendix D for genotyping results).

7.5 Discussion

The *Vanin-1* *-/-* mouse contains a targeted deletion of *Vanin-1* causing a complete absence of protein from the animal. Initial data suggested that these mice were able to breed normally and that no abnormality in the sex ratio was observed. To study the gonadal development of the *Vanin-1* *-/-* mouse a comparative study of various testicular markers was undertaken.

No significant differences in expression patterns were observed between *Vanin-1* *-/-* mice and BALB/c controls. A slight reduction in intensity of signal could be seen with *Ptc-1*, *Sccl*, *3 β HSD*, and p75NTR in BALB/c gonads, though this was probably due to a delay in the development of these gonads in comparison to the *Vanin-1* *-/-* gonads.

When gonads from the *Vanin-1* *-/-* mouse were placed in culture they developed testis cords as successfully as BALB/c controls. Furthermore, the addition of mAb 407 had no effect on the ability of *Vanin-1* *-/-* gonads to form cords in culture, indicating that the effects of mAb 407 on wild-type gonad formation in culture is mediated specifically by the presence of Vanin-1. This is also illustrated by the marker analysis performed on these cultured gonads.

From these results it is clear that the absence of Vanin-1 has no effect on the development of the gonads *in vivo*. One explanation for this discrepancy between the *in vitro* blocking effect of mAb 407 and the development of *Vanin-1* *-/-* embryonic gonads could be that the activity of another, perhaps similar, molecule is compensating for the loss of Vanin-1 activity in the mutant gonads. The effect of adding blocking antibody to explanted gonads *in vitro* may be to reduce the impact of any such compensating mechanism. Two other Vanin molecules exist, namely Vanin-2 and Vanin-3. Vanin-2 (VNN2) has been found in humans and is a GPI-anchored molecule at the cell surface. However, no cognate for this gene has been found in mice.

Vanin-3 has been isolated in the liver of adult mice and therefore could be responsible for any functional redundancy. To test for this possibility, *Vanin-3* expression was investigated in the developing gonads. No expression was observed in wild-type or *Vanin-1* *-/-* mice which suggests that Vanin-3 is not acting in this manner.

Another explanation for the *in vitro/in vivo* discrepancy might be that the effect of mAb 407 is not equivalent to a simple loss-of-function mutation. mAb 407 may alter the activity of Vanin-1 in some way, mimicking a gain-of-function mutation. It might be fruitful, therefore, to learn more about the interaction of mAb 407 and Vanin-1.

It is well established that genetic background can affect how the loss of a gene is manifested phenotypically in the mouse. The *Vanin-1* null mutation was therefore back-crossed from a BALB/c background to C3H/HeH. Homozygous mutant embryos were produced after five generations of back-crossing and gonads dissected at 13.5 dpc to observe any changes in testis development. Unfortunately no *Vanin-1* *-/-* testes were isolated. Despite this, adult mice were generated which included *Vanin-1* *-/-* males and these exhibited normal testicular development. Thus, changing the genetic background has no obvious effect on the development of the *Vanin-1* *-/-* mouse. Currently these mice are being examined to verify that they are fertile.

7.6 Summary

- Essentially no differences were observed between *Vanin-1* ^{-/-} gonads and BALB/c gonads at 13.5 dpc. Analysis of various testicular cell markers by WMISH and immunohistochemistry revealed very similar expression patterns.
- mAb 407 did not inhibit cord formation in *Vanin-1* ^{-/-} gonads *in vitro*, furthermore, these gonads did develop as successfully as wild-type gonads when no mAb 407 was added to the culture.
- No *Vanin-3* expression was detected in wild-type or *Vanin-1* ^{-/-} gonads at 13.5 dpc.
- Preliminary back-cross studies indicate that changing the genetic background of the *Vanin-1* null mutation from BALB/c to C3H/HeH does not obviously alter the phenotype of these mice.

Chapter 8: General Discussion

8.1 Findings of this study

The starting point of this study was an expression-based screen to identify candidate genes involved in sexual development. This analysis was performed by wholemount *in situ* hybridisation (WMISH). Two genes, *Gata2* and *Vanin-1*, were chosen for further analysis.

8.1.1 *Gata2*

Gata2 was chosen for further analysis based on its specific expression in the developing ovary. This expression was found to be located in the primordial germ cells between 11.5 dpc and 14.5 dpc. This expression pattern coincided with the reactivation of the silent X chromosome. Expression was then studied in embryos which contain only one X chromosome and hence do not undergo this process. Absence of *Gata2* expression in these embryos would suggest a direct link to X chromosome re-activation. However, *Gata2* expression was found to be unaltered. Nevertheless, this result does not rule out a potential role for *Gata2* in this process.

8.1.2 *Vanin-1*

Vanin-1 was found to be expressed in the supporting cell lineage immediately prior to overt testis cord formation. Blocking of Vanin-1 protein in an *in vitro* organ culture system resulted in the failure of testis cords to

form in the XY gonad. However, analysis of the *Vanin-1*^{-/-} mouse revealed no abnormalities in the developing testis *in vivo* in the absence of Vanin-1.

8.2 Further analysis of *Gata2*

In order to determine the physiological role of *Gata2* *in vivo* it is necessary to examine mice lacking the protein. Mice homozygous for a null allele of *Gata2* have been generated and die by 11.5 dpc (Tsai et al., 1994). Studies of a partial rescue did not report on any female abnormalities. A more definitive way to study the role of *Gata2* in ovary development would be to generate a cell-type-specific mutation using the Cre-Lox system. However, a limitation of this approach is the requirement for transgenic lines with restricted Cre expression in the developing ovary. Cre-expressing transgenes exist in the postnatal ovary, for example, *Msx2Cre* (Lan et al., 2003), but to date no lines have been produced for the specific excision of conditionally targeted genes in the embryonic ovary.

8.2 Further analysis of *Vanin-1*

As mentioned in Chapter 7, the effect of genetic background on testis development can be important (Albrecht et al., 2000). Preliminary studies of the effects of changing the background of the *Vanin-1* null mutation from BALB/c to C3H/HeH have been performed. Heterozygote inter-cross litters have been generated, but these exhibit no alteration in the sex ratio or loss of

any homozygous males. However, further analyses are still to be performed. For example, no homozygous male gonads have yet been isolated at 13.5 dpc. Examination of gonads at this age would allow detection of any defects in the developing testis cords.

Vanin-1 is a candidate for regulation by male-specific transcription factors. An investigation of the *Vanin-1* promoter/enhancers might prove to be an important step in testing this hypothesis. However, the transgenic studies reported here were unsuccessful in locating any enhancer elements which drive the gonadal expression of *Vanin-1*. One reason for this lack of success could be the failure of the *lacZ*-reporter construct to function properly. Therefore, this study is being repeated with the addition of buffer sequences at the ends of the construct in order to protect against any loss of important construct sequences by nuclease activity.

Another approach to determining the role of *Vanin-1* in gonadogenesis could be to look for genes which interact with *Vanin-1* by using a sensitised genetic screen. This would involve the use of the *Vanin-1* *-/-* mouse in an ENU (ethyl N-nitrosourea) mutagenesis study. This alkylating agent induces point mutations in premeiotic spermatogonial stem cells (Rinchik, 1991) and has been used in a variety of phenotype driven screens (Herron et al., 2002; Kasarskis et al., 1998). A sensitised screen would involve breeding ENU-induced mutations onto a *Vanin-1* *-/-* background. Mutations in modifier loci could be identified by the appearance of a phenotype on the *Vanin-1* *-/-*

background. These could be mapped and the underlying mutations identified. Screening for such loci may result in the identification of new genes involved in the developmental pathway in question. In this instance such an approach may result in the identification of genes that compensate for the absence of Vanin-1 in the homozygous mutant individuals.

This study implemented the use of a Vanin-1 monoclonal antibody (mAb 407) to block the function of this protein *in vitro*. As stated previously, this approach has been a long established technique used in different organ culture systems. However, this approach has not been used before to study the effects of inhibiting protein function in the developing gonad. Furthermore, it is unknown how this antibody interacts with Vanin-1. This study has demonstrated that the effects of mAb 407 are mediated by its specific interaction with Vanin-1, but the nature of this interaction is unknown. For example, does this antibody modify the function of Vanin-1 in some way, as opposed to merely ablating its function? The absence of a phenotype in *Vanin-1* $-/-$ mice may suggest so.

Two other methods can be employed in a similar organ culture study whereby the activity of Vanin-1 is ablated in a more controlled manner.

Firstly, antisense morpholino oligonucleotides can be used in organ culture. Morpholinos can be designed to inhibit the translation of mRNA from a target gene (in this instance, *Vanin-1*) and are designed to be complementary, and therefore bind to, the mRNA AUG translational start

site and the 22 bases 3' to that site. Translation is inhibited solely by a steric block mechanism. Therefore the expression of Vanin-1 can be blocked. This would therefore have the advantage of swiftness in assessing the role of a gene in gonad development combined with the known method of interaction with the target gene. Morphant technology has been used successfully in the mouse (Coonrod et al., 2001) and in rat organ culture (Roberts et al., 2002) where it was used to study Amh-induced cell death in the developing male mesonephros.

Secondly RNA interference technology (RNAi) could be used in an organ culture system. Specific mRNAs can be degraded by RNAi when double-stranded RNA corresponding to that mRNA sequence is introduced to a cell. This RNAi can be performed by addition of small interfering RNAs (siRNA) exogenously in order to silence post-transcriptional gene expression. This is achieved by the direct cleavage of mRNA in a sequence-specific manner *via* the action of an RNA nuclease, or by blocking of translation. Studies in post-implantation mouse embryos have utilised this technology effectively to knock-down specific genes (Gratsch et al., 2003). Therefore, the specific ablation of Vanin-1 could be achieved, again in a more specific and controlled manner. This RNAi strategy has been used successfully in mammalian organ culture systems (Davies et al., 2004). Furthermore, these approaches can be used to study the functions of other genes that may play a

role in gonad development and can be used as a more rapid alternative to traditional generation of null mutations.

8.3 Success of this screen

8.3.1 Initial aims of this thesis: identification of new genes using a gene-based approach

The initial aims of this thesis were to identify and analyse new genes involved in mouse gonad development, particularly genes from new functional classes. This was achieved by a gene-based approach whereby genes are selected for further study based on their expression profile and previous functional annotation. On this basis therefore, the identification of *Gata2* and *Vanin-1* has fulfilled the first aim. This highlights one major advantage with this type of approach for finding new genes involved in any process or pathway, namely the swiftness and success in candidate gene identification.

8.3.2 Drawbacks of this method

However, the functional analysis of these two genes, especially *Vanin-1* has proven to be more problematic. This highlights a major drawback in this gene-based approach, namely the difficulties in assigning a function to a particular gene.

One major way of assessing the physiological role of a gene is to examine mice lacking the protein. The generation of a tissue-specific null mutation of

Gata2 would greatly advance our understanding of the role of this gene in ovary development. However this would be technically demanding, as the generation of a transgenic line expressing Cre in the developing ovary would be required.

Mice homozygous for a null allele of *Vanin-1* (*Vanin-1* *-/-* mice) have been generated. However, these mice exhibit no obvious defects in the developing testis. This result is by no means a rare outcome in this type of study, and points to some kind of compensatory mechanism, or functional redundancy operating. An example of this type of mechanism can be seen when studying the role of the insulin-like growth factors (*Igf*) in early gonadogenesis (Nef et al., 2003). Null mutations in each family member (*Ir*-insulin receptor, *Igf1r*-insulin-like growth factor 1, *Irr*-insulin-receptor-related receptor) produced no defects in sexual development. However, the production of triple-gene null embryos caused complete male-to-female sex reversal.

Another member of the Vanin family, *Vanin-3*, exists in the mouse and may play a role in compensating for the loss of *Vanin-1*. Mice homozygous for a null mutation of *Vanin-3* could be crossed to *Vanin-1* *-/-* mice to generate doubly homozygous mutant animals and any gonad phenotype investigated. However, in this thesis, no evidence for *Vanin-3* expression in the developing testis has been found.

8.4 Another gene-based mutagenesis approach for finding and analysing new genes

This study used WMISH to generate candidate genes with a potential to function during gonad development. Further functional studies are then subsequently performed, with the generation of a null mutation by homologous recombination being the most informative. Another method of generating mutations in candidate genes is to screen archived DNA from ENU mutagenised mice (Cox and Brown, 2003; Hrabe de Angelis et al., 2000; Nolan et al., 2000a; Nolan et al., 2000b). One advantage of this approach is the potential range of alleles which can be isolated from a series of different point mutations. For example, new alleles of *Vanin-1* may be isolated, including hypomorphic, gain-of-function and dominant negative mutations, as well as new null alleles.

Coghill et al. (Coghill et al., 2002) utilized archived DNA and frozen sperm from F1 progeny of mutagenized males. Mice were then re-derived *via* IVF from the frozen sperm. Four genes were scanned for mutations, resulting in three functional changes in one gene, Connexin 26, and one null mutation. ENU-treated embryonic stem (ES) cells can also be screened. Replica libraries are frozen and DNA prepared from one of these (Munroe et al., 2000). Clearly, this technique can also be implemented in the search for new mutations in genes already known to be involved in mouse gonad development.

8.5 Phenotype-driven screens: an alternative approach to finding new genes

As mentioned previously, one major drawback in the use of gene-based/driven screens is that once a gene has been shown to be a potential candidate in a given process determining its function can prove to be elusive. A different method to finding and analysing new genes is to screen progeny from ENU-mutagenised males for defects in gonad development. This way the function of any gene can be initially determined by the appearance of a phenotype, followed by the slower step of ascertaining which gene is responsible for the aberrant phenotype. This approach has proved very effective in finding new genes involved in a variety of developmental processes (for example, Herron et al., 2002, Nolan et al., 2000a). Additionally, screens can be performed on a transgenic background. For example, transgenic lines can be used which carry the reporter gene GFP driven by the promoter of a known gene expressed in (pre-) Sertoli cells. Any change in expression pattern that might suggest a developmental abnormality can be rapidly visualised and studied further. Breeding schemes can be used to allow the identification of both dominant and recessive mutant alleles in such a screen. Clearly, the identification of recessive alleles is likely to be required to study the function of genes involved in gonadogenesis due to probable effects on fertility.

8.6 Future studies

Many gaps in our knowledge of sexual development are still apparent. For example, the target(s) of *Sry* are still not known and the nature of interactions between *Sry*, *Sox9*, *Fgf9* and *Dax1* remain unclear. Furthermore, when new genes are eventually discovered, how these fit into the sexual developmental pathway will need to be elucidated. Genetic blueprints by themselves tell us very little about the functional behaviour of cells and multi-cellular organisms. Most cellular functions are carried out by groups of molecules, creating a network within and between cells (Oltvai and Barabasi, 2002). Understanding these interactions will be a major challenge and requires the generation of many more mutant phenotypes, including those derived from multiple defective genomes. Development of new techniques, for example the use of proteomics and real-time imaging, will help us to gain insight into how various molecules interact with each other and determine how these networks control cellular behaviour during mammalian development.

References

- Albrecht, K. H., Capel, B., Washburn, L. L. and Eicher, E. M. (2000). Defective mesonephric cell migration is associated with abnormal testis cord development in C57BL/6J XY(Mus domesticus) mice. *Dev Biol* 225, 26-36.
- Arango, N. A., Lovell-Badge, R. and Behringer, R. R. (1999). Targeted mutagenesis of the endogenous mouse *Mis* gene promoter: in vivo definition of genetic pathways of vertebrate sexual development. *Cell* 99, 409-19.
- Aurrand-Lions, M., Galland, F., Bazin, H., Zakharyev, V. M., Imhof, B. A. and Naquet, P. (1996). Vanin-1, a novel GPI-linked perivascular molecule involved in thymus homing. *Immunity* 5, 391-405.
- Barboux, S., Niaudet, P., Gubler, M. C., Grunfeld, J. P., Jaubert, F., Kuttann, F., Fekete, C. N., Souleyreau-Therville, N., Thibaud, E., Fellous, M. et al. (1997). Donor splice-site mutations in *WT1* are responsible for Frasier syndrome. *Nat Genet* 17, 467-70.
- Bardoni, B., Zanaria, E., Guioli, S., Florida, G., Worley, K. C., Tonini, G., Ferrante, E., Chiumello, G., McCabe, E. R. B., Fraccaro, M. et al. (1994). A dosage sensitive locus at chromosome Xp21 is involved in male to female sex reversal. *Nature Genetics* 7, 497-501.
- Bedell, M. A., Brannan, C. I., Evans, E. P., Copeland, N. G., Jenkins, N. A. and Donovan, P. J. (1995). DNA rearrangements located over 100 kb 5' of the *Steel* (*Sl*)-coding region in *Steel-panda* and *Steel-contrasted* mice deregulate *Sl* expression and cause female sterility by disrupting ovarian follicle development. *Genes Dev* 9, 455-70.
- Behringer, R. B., Cate, R. L., Froelick, G. J., Palmiter, R. D. and Brinster, R. L. (1990). Abnormal sexual development in transgenic mice chronically expressing Müllerian inhibiting substance. *Nature* 345, 167-170.
- Behringer, R. R., Finegold, M. J. and Cate, R. L. (1994). Müllerian-Inhibiting Substance function during mammalian sexual development. *Cell* 79, 415-425.
- Bishop, C. E., Whitworth, D. J., Qin, Y., Agoulnik, A. I., Agoulnik, I. U., Harrison, W. R., Behringer, R. R. and Overbeek, P. A. (2000). A transgenic insertion upstream of *sox9* is associated with dominant XX sex reversal in the mouse. *Nat Genet* 26, 490-4.
- Bitgood, M. J., Shen, L. and McMahon, A. P. (1996). Sertoli cell signaling by *Desert Hedgehog* regulates the male germline. *Current Biol.* 6, 298-304.

- Bonaldo, M F, Lennon, G and Soares, M B. (1996). Normalization and subtraction: two approaches to facilitate gene discovery. *Genome Res.* 6, 791-806.
- Bowles, J., Bullejos, M. and Koopman, P. (2000). A subtractive gene expression screen suggests a role for vanin-1 in testis development in mice. *Genesis* 27, 124-135.
- Brennan, J., Karl, J. and Capel, B. (2002). Divergent vascular mechanisms downstream of Sry establish the arterial system in the XY gonad. *Dev Biol* 244, 418-28.
- Brennan, J., Karl, J., Martineau, J., Nordqvist, K., Schmahl, J., Tilmann, C., Ung, K. and Capel, B. (1998). Sry and the testis: molecular pathways of organogenesis. *J Exp Zool* 281, 494-500.
- Brennan, J., Tilmann, C. and Capel, B. (2003). Pdgfr-alpha mediates testis cord organization and fetal Leydig cell development in the XY gonad. *Genes Dev* 17, 800-10.
- Buehr, M., Gu, S. and McLaren, A. (1993a). Mesonephric contribution to testis differentiation in the fetal mouse. *Development* 117, 273-281.
- Buehr, M., McLaren, A., Bartley, A. and Darling, S. (1993b). Proliferation and migration of primordial germ cells in We/We mouse embryos. *Dev Dyn* 198, 182-9.
- Bullejos, M., Bowles, J. and Koopman, P. (2002). Extensive vascularization of developing mouse ovaries revealed by caveolin-1 expression. *Dev Dyn* 225, 95-9.
- Bullejos, M. and Koopman, P. (2001). Spatially dynamic expression of Sry in mouse genital ridges. *Dev Dyn* 221, 201-5.
- Burgoyne, P. S., Buehr, M., Koopman, P., Rossant, J. and McLaren, A. (1988). Cell-autonomous action of the testis-determining gene: Sertoli cells are exclusively XY in XX----XY chimaeric mouse testes. *Development* 102, 443-50.
- Campagnolo, L., Russo, M. A., Puglianiello, A., Favale, A. and Siracusa, G. (2001). Mesenchymal cell precursors of peritubular smooth muscle cells of the mouse testis can be identified by the presence of the p75 neurotrophin receptor. *Biol Reprod* 64, 464-72.
- Canning, C. A. and Lovell-Badge, R. (2002). Sry and sex determination: how lazy can it be? *Trends Genet* 18, 111-3.
- Capel, B. (2000). The battle of the sexes. *Mech Dev* 92, 89-103.

Capel, B., Albrecht, K. H., Washburn, L. L. and Eicher, E. M. (1999). Migration of mesonephric cells into the mammalian gonad depends on Sry. *Mech Dev* 84, 127-31.

Carulli, J. P., Artinger, M., Swain, P. M., Root, C. D., Chee, L., Tulig, C., Guerin, J., Osborne, M., Stein, G., Lian, J. et al. (1998). High throughput analysis of differential gene expression. *J Cell Biochem Suppl* 31, 286-96.

Chaboissier, M. C., Kobayashi, A., Vidal, V. I., Lutzkendorf, S., van de Kant, H. J., Wegner, M., de Rooij, D. G., Behringer, R. R. and Schedl, A. (2004). Functional analysis of Sox8 and Sox9 during sex determination in the mouse. *Development* 131, 1891-901.

Clark, A. M., Garland, K. K. and Russell, L. D. (2000). Desert hedgehog (Dhh) gene is required in the mouse testis for formation of adult-type Leydig cells and normal development of peritubular cells and seminiferous tubules. *Biol Reprod* 63, 1825-38.

Coghill, E. L., Hugill, A., Parkinson, N., Davison, C., Glenister, P., Clements, S., Hunter, J., Cox, R. D. and Brown, S. D. (2002). A gene-driven approach to the identification of ENU mutants in the mouse. *Nat Genet* 30, 255-6.

Colvin, J. S., Green, R. P., Schmahl, J., Capel, B. and Ornitz, D. M. (2001). Male-to-female sex reversal in mice lacking fibroblast growth factor 9. *Cell* 104, 875-89.

Coonrod, S. A., Bolling, L. C., Wright, P. W., Visconti, P. E. and Herr, J. C. (2001). A morpholino phenocopy of the mouse mos mutation. *Genesis* 30, 198-200.

Cox, R. D. and Brown, S. D. (2003). Rodent models of genetic disease. *Curr Opin Genet Dev* 13, 278-83.

da Silva, S. M., Hacker, A., Harley, V., Goodfellow, P., Swain, A. and Lovell-Badge, R. (1996). Sox9 expression during gonadal development implies a conserved role for the gene in testis differentiation in mammals and birds. *Nature Genetics* 14, 62-67.

Davies, J. A., Lodomery, M., Hohenstein, P., Michael, L., Shafe, A., Spraggon, L. and Hastie, N. (2004). Development of an siRNA-based method for repressing specific genes in renal organ culture and its use to show that the Wt1 tumour suppressor is required for nephron differentiation. *Hum Mol Genet* 13, 235-46.

Davies, J. A., Millar, C. B., Johnson, E. M., Jr. and Milbrandt, J. (1999). Neurturin: an autocrine regulator of renal collecting duct development. *Dev Genet* 24, 284-92.

De Santa Barbara, P., Bonneaud, N., Boizet, B., Desclozeaux, M., Moniot, B., Sudbeck, P., Scherer, G., Poulat, F. and Berta, P. (1998). Direct interaction of SRY-related protein SOX9 and steroidogenic factor 1 regulates transcription of the human anti-Mullerian hormone gene. *Mol Cell Biol* 18, 6653-65.

Deltour, L., Haselbeck, R. J., Ang, H. L. and Duester, G. (1997). Localization of class I and class IV alcohol dehydrogenases in mouse testis and epididymis: potential retinol dehydrogenases for endogenous retinoic acid synthesis. *Biol Reprod* 56, 102-9.

di Clemente, N., Wilson, C., Faure, E., Boussin, L., Carmillo, P., Tizard, R., Picard, J. Y., Vigier, B., Josso, N. and Cate, R. (1994). Cloning, expression, and alternative splicing of the receptor for anti-Mullerian hormone. *Mol Endocrinol* 8, 1006-20.

Duester, G. (2000). Families of retinoid dehydrogenases regulating vitamin A function: production of visual pigment and retinoic acid. *Eur J Biochem* 267, 4315-24.

Falk, M., Salmivirta, K., Durbeej, M., Larsson, E., Ekblom, M., Vestweber, D. and Ekblom, P. (1996). Integrin alpha 6B beta 1 is involved in kidney tubulogenesis in vitro. *J Cell Sci* 109 (Pt 12), 2801-10.

Fisher, R.A (1934). Statistical methods for research workers. 5th edition 9 Oliver and Boyd, Edinburgh)

Galland, F., Malergue, F., Bazin, H., Mattei, M. G., Aurrand-Lions, M., Theillet, C. and Naquet, P. (1998). Two human genes related to murine vanin-1 are located on the long arm of human chromosome 6. *Genomics* 53, 203-13.

Giese, K., Cox, J. and Grosschedl, R. (1992). The HMG Domain of Lymphoid Enhancer Factor 1 Bends DNA and Facilitates Assembly of Functional Nucleoprotein Structures. *Cell* 69, 185-195.

Giese, K., Pagel, J. and Grosschedl, R. (1994). Distinct DNA-binding properties of the high mobility group domain of murine and human SRY sex-determining factors. *Proc. Natl. Acad. Sci.* 91, 3368-3374.

Ginsburg, M., Snow, M. H. and McLaren, A. (1990). Primordial germ cells in the mouse embryo during gastrulation. *Development* 110, 521-8.

Granjeaud, S., Naquet, P. and Galland, F. (1999). An ESTs description of the new Vanin gene family conserved from fly to human. *Immunogenetics* 49, 964-72.

Gratsch, T. E., De Boer, L. S. and O'Shea, K. S. (2003). RNA inhibition of BMP-4 gene expression in postimplantation mouse embryos. *Genesis* 37, 12-7.

Greenfield, A. and Koopman, P. (1996). *SRY* and Mammalian Sex Determination. *Current Topics in Developmental Biology* 34, 1-23.

Grimmond, S., Van Hateren, N., Siggers, P., Arkell, R., Larder, R., Soares, M. B., de Fatima Bonaldo, M., Smith, L., Tymowska-Lalanne, Z., Wells, C. et al. (2000).

Sexually dimorphic expression of protease nexin-1 and vanin-1 in the developing mouse gonad prior to overt differentiation suggests a role in mammalian sexual development. *Hum Mol Genet* 9, 1553-60.

Gubbay, J., Collignon, J., Koopman, P., Capel, B., Economou, A., Munsterberg, A., Vivian, N., Goodfellow, P. and Lovell-Badge, R. (1990). A gene mapping to the sex-determining region of the mouse Y chromosome is a member of a novel family of embryonically expressed genes. *Nature* 346, 245-50.

Gubbay, J., Vivian, N., Economou, A., Jackson, D., Goodfellow, P. and Lovell-Badge, R. (1992). Inverted repeat structure of the Sry locus in mice. *Proceedings of the National Academy of Sciences USA* 89, 7953-7957.

Guo, J. K., Hammes, A., Chaboissier, M. C., Vidal, V., Xing, Y., Wong, F. and Schedl, A. (2002). Early gonadal development: exploring Wt1 and Sox9 function. *Novartis Found Symp* 244, 23-31; discussion 31-42, 253-7.

Guo, W., Mason, J. S., Stone, C. G., Jr., Morgan, S. A., Madu, S. I., Baldini, A., Lindsay, E. A., Biesecker, L. G., Copeland, K. C., Horlick, M. N. et al. (1995). Diagnosis of X-linked adrenal hypoplasia congenita by mutation analysis of the DAX1 gene. *Jama* 274, 324-30.

Hacker, A., Capel, B., Goodfellow, P. and Lovell-Badge, R. (1995a). Expression of Sry, the mouse sex determining gene. *Development* 121, 1603-14.

Hacker, A., Capel, B., Goodfellow, P. and Lovell-Badge, R. (1995b). Expression of Sry, the mouse testis-determining gene. *Development* 121, 1603-1614.

Hammes, A., Guo, J. K., Lutsch, G., Leheste, J. R., Landrock, D., Ziegler, U., Gubler, M. C. and Schedl, A. (2001). Two splice variants of the Wilms' tumor 1 gene have distinct functions during sex determination and nephron formation. *Cell* 106, 319-29.

Herron, B. J., Lu, W., Rao, C., Liu, S., Peters, H., Bronson, R. T., Justice, M. J., McDonald, J. D. and Beier, D. R. (2002). Efficient generation and mapping of recessive developmental mutations using ENU mutagenesis. *Nat Genet* 30, 185-9.

Hirai, Y., Takebe, K., Takashina, M., Kobayashi, S. and Takeichi, M. (1992). Epimorphin: a mesenchymal protein essential for epithelial morphogenesis. *Cell* 69, 471-81.

Hrabe de Angelis, M. H., Flaswinkel, H., Fuchs, H., Rathkolb, B., Soewarto, D., Marschall, S., Heffner, S., Pargent, W., Wuensch, K., Jung, M. et al. (2000). Genome-wide, large-scale production of mutant mice by ENU mutagenesis. *Nat Genet* 25, 444-7.

- Huang, E. J., Manova, K., Packer, A. I., Sanchez, S., Bachvarova, R. F. and Besmer, P. (1993). The murine steel panda mutation affects kit ligand expression and growth of early ovarian follicles. *Dev Biol* 157, 100-9.
- Hubbard, T., Barker, D., Birney, E., Cameron, G., Chen, Y., Clark, L., Cox, T., Cuff, J., Curwen, V., Down, T. et al. (2002). The Ensembl genome database project. *Nucleic Acids Res* 30, 38-41.
- Ikeda, Y., Shen, W. H., Ingraham, H. A. and Parker, K. L. (1994). Developmental expression of mouse steroidogenic factor-1, an essential regulator of the steroid hydroxylases. *Mol Endocrinol* 8, 654-62.
- Ikeda, Y., Swain, A., Weber, T. J., Hentges, K. E., Zanaria, E., Lalli, E., Tamai, K. T., Sassone-Corsi, P., Lovell-Badge, R., Camerino, G. et al. (1996). Steroidogenic factor 1 and Dax-1 colocalize in multiple cell lineages: potential links in endocrine development. *Mol Endocrinol* 10, 1261-72.
- Ingraham, H. A., Lala, D. S., Ikeda, Y., Luo, X., Shen, W. H., Nachtigal, M. W., Abbud, R., Nilson, J. H. and Parker, K. L. (1994). The nuclear receptor steroidogenic factor 1 acts at multiple levels of the reproductive axis. *Genes Dev* 8, 2302-12.
- Ito, M., Yu, R. N. and Jameson, J. L. (1998). Steroidogenic factor-1 contains a carboxy-terminal transcriptional activation domain that interacts with steroid receptor coactivator-1 [In Process Citation]. *Mol Endocrinol* 12, 290-301.
- Jeays-Ward, K., Hoyle, C., Brennan, J., Dandonneau, M., Allodus, G., Capel, B. and Swain, A. (2003). Endothelial and steroidogenic cell migration are regulated by WNT4 in the developing mammalian gonad. *Development* 130, 3663-70.
- Jeske, Y. W. A., Bowles, J., Greenfield, A. and Koopman, P. (1995). Expression of a linear Sry transcript in the mouse genital ridge. *Nature Genetics* 10, 480-482.
- Johnson, F. M., Chasalow, F., Lewis, S. E., Barnett, L. and Lee, C. Y. (1981). A null allele at the Mod-1 locus of the mouse. *J Hered* 72, 134-6.
- Jost, A. (1947). Recherches sur la differentiation sexuelle de l'embryon de lapin. *Archives d'Anatomie et Microscopie Morphologie Experimentale* 36, 271-315.
- Jost, A., Vigier, B., Prepin, J. and Perchellet, J. P. (1973). Studies in sex differentiation in mammals. In *Symposium on Intersexuality*, pp. 392-406. New York: Springer.
- Karl, J. and Capel, B. (1998). Sertoli cells of the mouse testis originate from the coelomic epithelium. *Dev Biol* 203, 323-33.

- Kasarskis, A., Manova, K. and Anderson, K. V. (1998). A phenotype-based screen for embryonic lethal mutations in the mouse. *Proc Natl Acad Sci US A* 95, 7485-90.
- Kent, J., Wheatley, S. C., Andrews, J. E., Sinclair, A. H. and Koopman, P. (1996). A male-specific role for SOX9 in vertebrate sex determination. *Development* 122, 2813-22.
- Ko, M. S., Kitchen, J. R., Wang, X., Threat, T. A., Hasegawa, A., Sun, T., Grahovac, M. J., Kargul, G. J., Lim, M. K., Cui, Y. et al. (2000). Large-scale cDNA analysis reveals phased gene expression patterns during preimplantation mouse development. *Development* 127, 1737-49.
- Konishi, I., Fujii, S., Okamura, H., Parmley, T. and Mori, T. (1986). Development of interstitial cells and ovigerous cords in the human fetal ovary: an ultrastructural study. *J Anat* 148, 121-35.
- Koopman, P., Bullejos, M. and Bowles, J. (2001). Regulation of male sexual development by Sry and Sox9. *J Exp Zool* 290, 463-74.
- Koopman, P., Bullejos, M., Loffler, K. and Bowles, J. (2002). Expression-based strategies for discovery of genes involved in testis and ovary development. *Novartis Found Symp* 244, 240-9; discussion 249-57.
- Koopman, P., Gubbay, J., Vivian, N., Goodfellow, P. and Lovell-Badge, R. (1991). Male development of chromosomally female mice transgenic for Sry. *Nature* 351, 117-121.
- Koopman, P., Munsterberg, A., Capel, B., Vivian, N. and Lovell-Badge, R. (1990). Expression of a candidate sex-determining gene during mouse testis differentiation. *Nature* 348, 450-2.
- Kreidberg, J. A., Sariola, H., Loring, J. M., Maeda, M., Pelletier, J., Housman, D. and Jaenisch, R. (1993). WT-1 is required for early kidney development. *Cell* 74, 679-691.
- Lan, Z. J., Xu, X. and Cooney, A. J. (2003). Generation of a germ cell nuclear factor conditional allele in mice. *Genesis* 37, 172-9.
- Leimeister, C., Externbrink, A., Klamt, B. and Gessler, M. (1999). Hey genes: a novel subfamily of hairy- and Enhancer of split related genes specifically expressed during mouse embryogenesis. *Mech Dev* 85, 173-7.
- Loffler, K. A. and Koopman, P. (2002). Charting the course of ovarian development in vertebrates. *Int J Dev Biol* 46, 503-10.

- Luo, X., Ikeda, Y. and Parker, K. L. (1994). A cell-specific nuclear receptor is essential for adrenal and gonadal development and sexual differentiation. *Cell* 77, 481-490.
- Martin, F., Malergue, F., Pitari, G., Philippe, J. M., Philips, S., Chabret, C., Granjeaud, S., Mattei, M. G., Mungall, A. J., Naquet, P. et al. (2001). Vanin genes are clustered (human 6q22-24 and mouse 10A2B1) and encode isoforms of pantetheinase ectoenzymes. *Immunogenetics* 53, 296-306.
- Martin, F., Penet, M. F., Malergue, F., Lepidi, H., Dessein, A., Galland, F., de Reggi, M., Naquet, P. and Gharib, B. (2004). Vanin-1(-/-) mice show decreased NSAID- and Schistosoma-induced intestinal inflammation associated with higher glutathione stores. *J Clin Invest* 113, 591-7.
- Martineau, J., Nordqvist, K., Tilmann, C., Lovell-Badge, R. and Capel, B. (1997). Male-specific cell migration into the developing gonad. *Curr Biol* 7, 958-68.
- McClive, P. J., Hurley, T. M., Sarraj, M. A., van den Bergen, J. A. and Sinclair, A. H. (2003). Subtractive hybridisation screen identifies sexually dimorphic gene expression in the embryonic mouse gonad. *Genesis* 37, 84-90.
- McElreavey, K., Vilain, E., Herskowitz, I. and Fellous, M. (1993). A regulatory cascade hypothesis for mammalian sex determination: SRY represses a negative regulator of male development. *Proceedings of the National Academy of Sciences USA* 90, 3368-3372.
- McLaren, A. (1995). Germ cells and germ cell sex. *Philos Trans R Soc Lond B Biol Sci* 350, 229-33.
- McLaren, A. and Southee, D. (1997). Entry of mouse embryonic germ cells into meiosis. *Dev Biol* 187, 107-13.
- McMahon, A, Fosten, M, Monk, M. (1981). Random X-chromosome inactivation in female primordial germ cells in the mouse. *J Embryol Exp Morphol* 64, 251-8.
- Monk, M, McLaren, A. (1981). X-chromosome activity in foetal germ cells of the mouse. *J Embryol Exp Morph.* 63, 75-84.
- Menke, A. L., van der Eb, A. J. and Jochemsen, A. G. (1998). The Wilms' tumor 1 gene: oncogene or tumor suppressor gene? *Int Rev Cytol* 181, 151-212.
- Menke, D. B., Koubova, J. and Page, D. C. (2003). Sexual differentiation of germ cells in XX mouse gonads occurs in an anterior-to-posterior wave. *Dev Biol* 262, 303-12.

Merchant-Larios, H., Moreno-Mendoza, N. and Buehr, M. (1993). The role of the mesonephros in cell differentiation and morphogenesis of the mouse fetal testis. *Int J Dev Biol* 37, 407-15.

Mizusaki, H., Kawabe, K., Mukai, T., Ariyoshi, E., Kasahara, M., Yoshioka, H., Swain, A. and Morohashi, K. (2003). Dax-1 (dosage-sensitive sex reversal-adrenal hypoplasia congenita critical region on the x chromosome, gene 1) gene transcription is regulated by wnt4 in the female developing gonad. *Mol Endocrinol* 17, 507-19.

Munroe, R. J., Bergstrom, R. A., Zheng, Q. Y., Libby, B., Smith, R., John, S. W., Schimenti, K. J., Browning, V. L. and Schimenti, J. C. (2000). Mouse mutants from chemically mutagenized embryonic stem cells. *Nat Genet* 24, 318-21.

Münsterberg, A. and Lovell-Badge, R. (1991). Expression of the mouse anti-Müllerian hormone gene suggests a role in both female and male sexual differentiation. *Development* 113, 613-624.

Nef, S., Verma-Kurvari, S., Merenmies, J., Vassalli, J. D., Efstratiadis, A., Accili, D. and Parada, L. F. (2003). Testis determination requires insulin receptor family function in mice. *Nature* 426, 291-5.

Nichols, J., Zevnik, B., Anastasiadis, K., Niwa, H., Klewe-Nebenius, D., Chambers, I., Scholer, H. and Smith, A. (1998). Formation of pluripotent stem cells in the mammalian embryo depends on the POU transcription factor Oct4. *Cell* 95, 379-91.

Nolan, P. M., Peters, J., Strivens, M., Rogers, D., Hagan, J., Spurr, N., Gray, I. C., Vitor, L., Brooker, D., Whitehill, E. et al. (2000a). A systematic, genome-wide, phenotype-driven mutagenesis programme for gene function studies in the mouse. *Nat Genet* 25, 440-3.

Nolan, P. M., Peters, J., Vitor, L., Strivens, M., Washbourne, R., Hough, T., Wells, C., Glenister, P., Thornton, C., Martin, J. et al. (2000b). Implementation of a large-scale ENU mutagenesis program: towards increasing the mouse mutant resource. *Mamm Genome* 11, 500-6.

Odor, D. L. and Blandau, R. J. (1969). Ultrastructural studies on fetal and early postnatal mouse ovaries. I. Histogenesis and organogenesis. *Am J Anat* 124, 163-86.

Oltvai, Z. N. and Barabasi, A. L. (2002). Systems biology. Life's complexity pyramid. *Science* 298, 763-4.

Oulad-Abdelghani, M., Bouillet, P., Decimo, D., Gansmuller, A., Heyberger, S., Dolle, P., Bronner, S., Lutz, Y. and Chambon, P. (1996). Characterization of a premeiotic germ cell-specific cytoplasmic protein encoded by Stra8, a novel retinoic acid-responsive gene. *J Cell Biol* 135, 469-77.

- Palmer, G., Manen, D., Bonjour, J. and Caverzasio, J. (2000). Structure of the murine Pit1 phosphate transporter/retrovirus receptor gene and functional characterization of its promoter region. *Gene* 244, 35-45.
- Palmer, S. J. and Burgoyne, P. S. (1991). *In situ* analysis of fetal, prepuberal and adult XX×XY chimaeric mouse testes: Sertoli cells are predominantly, but not exclusively, XY. *Development* 112, 265-268.
- Pang, Z., Zuo, J. and Morgan, J. I. (2000). Cbln3, a novel member of the precerebellin family that binds specifically to Cbln1. *J Neurosci* 20, 6333-9.
- Pelletier, J., Bruening, W., Li, F. P., Haber, D. A., Glaser, T. and Housman, D. E. (1991). *WT1* mutations contribute to abnormal genital system development and hereditary Wilms' tumour. *Nature* 353, 431-434.
- Pesce, M., Wang, X., Wolgemuth, D. J. and Scholer, H. (1998). Differential expression of the Oct-4 transcription factor during mouse germ cell differentiation. *Mech Dev* 71, 89-98.
- Pierucci-Alves, F., Clark, A. M. and Russell, L. D. (2001). A developmental study of the Desert hedgehog-null mouse testis. *Biol Reprod* 65, 1392-402.
- Pitari, G., Malergue, F., Martin, F., Philippe, J. M., Massucci, M. T., Chabret, C., Maras, B., Dupre, S., Naquet, P. and Galland, F. (2000). Pantetheinase activity of membrane-bound Vanin-1: lack of free cysteamine in tissues of Vanin-1 deficient mice. *FEBS Lett* 483, 149-54.
- Pontiggia, A., Rimini, R., Harley, V. R., Goodfellow, P. N., Lovell-Badge, R. and Bianchi, M. E. (1994). Sex-reversing mutations affect the architecture of SRY-DNA complexes. *The EMBO Journal* 13, 6115-6124.
- Puglianiello, A., Campagnolo, L., Farini, D., Cipollone, D., Russo, M. A. and Siracusa, G. (2004). Expression and role of PDGF-BB and PDGFR- β during testis morphogenesis in the mouse embryo. *J Cell Sci* 117, 1151-1160.
- Qin, Y., Kong, L. K., Poirier, C., Truong, C., Overbeek, P. A. and Bishop, C. E. (2004). Long-range activation of Sox9 in Odd Sex (Ods) mice. *Hum Mol Genet* 13, 1213-8.
- Racine, C., Rey, R., Forest, M. G., Louis, F., Ferre, A., Huhtaniemi, I., Josso, N. and di Clemente, N. (1998). Receptors for anti-mullerian hormone on Leydig cells are responsible for its effects on steroidogenesis and cell differentiation. *Proc Natl Acad Sci USA* 95, 594-9.

- Raymond, C. S., Kettlewell, J. R., Hirsch, B., Bardwell, V. J. and Zarkower, D. (1999). Expression of *Dmrt1* in the genital ridge of mouse and chicken embryos suggests a role in vertebrate sexual development. *Dev Biol* 215, 208-20.
- Raymond, C. S., Murphy, M. W., O'Sullivan, M. G., Bardwell, V. J. and Zarkower, D. (2000). *Dmrt1*, a gene related to worm and fly sexual regulators, is required for mammalian testis differentiation. *Genes Dev* 14, 2587-95.
- Rinchik, E. M. (1991). Chemical mutagenesis and fine-structure functional analysis of the mouse genome. *Trends Genet* 7, 15-21.
- Roberts, L. M., Visser, J. A. and Ingraham, H. A. (2002). Involvement of a matrix metalloproteinase in MIS-induced cell death during urogenital development. *Development* 129, 1487-96.
- Rouiller, V., Gangnerau, M. N., Vayssiere, J. L. and Picon, R. (1990). Cholesterol side-chain cleavage activity in rat fetal gonads: a limiting step for ovarian steroidogenesis. *Mol Cell Endocrinol* 72, 111-20.
- Russo, M A, Giustizieri, M L, Favale, A, Fantini, M C, Campagnolo, L Konda, D, Germano, F Farini, D, Manna, C, Siracusa, G. (1999). Spatiotemporal patterns of expression of neurotrophins and neurotrophin receptors in mice suggest functional roles in testicular and epididymal morphogenesis. *Biol Reprod* 61, 1123-32.
- Sambrook, J., Fritsch, E. and Maniatis, T. (1989). *Molecular Cloning: A Laboratory Manual*. Cold Spring Harbour, New York: Cold Spring Harbour Laboratory Press.
- Schepers, G., Wilson, M., Wilhelm, D. and Koopman, P. (2003). SOX8 is expressed during testis differentiation in mice and synergizes with SF1 to activate the *Amh* promoter in vitro. *J Biol Chem* 278, 28101-8.
- Scherer, G., Held, M., Erdel, M., Meschede, D., Horst, J., Lesniewicz, R. and Midro, A. T. (1998). Three novel SRY mutations in XY gonadal dysgenesis and the enigma of XY gonadal dysgenesis cases without SRY mutations. *Cytogenet Cell Genet* 80, 188-92.
- Schmahl, J., Eicher, E. M., Washburn, L. L. and Capel, B. (2000). Sry induces cell proliferation in the mouse gonad. *Development* 127, 65-73.
- Schmahl, J., Kim, Y., Colvin, J. S., Ornitz, D. M. and Capel, B. (2004). Fgf9 induces proliferation and nuclear localization of FGFR2 in Sertoli precursors during male sex determination. *Development* 131, 3627-36.
- Scholer, H. R., Dressler, G. R., Balling, R., Rohdewohld, H. and Gruss, P. (1990). Oct-4: a germline-specific transcription factor mapping to the mouse t-complex. *Embo J* 9, 2185-95.

Schuger, L., Skubitz, A. P., O'Shea, K. S., Chang, J. F. and Varani, J. (1991). Identification of laminin domains involved in branching morphogenesis: effects of anti-laminin monoclonal antibodies on mouse embryonic lung development. *Dev Biol* 146, 531-41.

Sharpe, R. M. (2001). Hormones and testis development and the possible adverse effects of environmental chemicals. *Toxicol Lett* 120, 221-32.

Shen, W.-H., Moore, C. C. D., Ikeda, Y., Parker, K. L. and Ingraham, H. (1994). Nuclear receptor steroidogenic factor 1 regulates the Müllerian inhibiting substance gene: a link to the sex determination cascade. *Cell* 77, 651-661.

Simon, M. C. (1995). Gotta have GATA. *Nat Genet* 11, 9-11.

Smith, L. (2003). A single primer cDNA amplification method for DNA microarray expression analysis. *Nucleic Acids Research*.

Smith, L. and Greenfield, A. (2003). DNA microarrays and development. *Hum Mol Genet* 12 Spec No 1, R1-8.

Sorokin, L. M., Conzelmann, S., Ekblom, P., Battaglia, C., Aumailley, M. and Timpl, R. (1992). Monoclonal antibodies against laminin A chain fragment E3 and their effects on binding to cells and proteoglycan and on kidney development. *Exp Cell Res* 201, 137-44.

Strahle, U., Blader, P., Adam, J. and Ingham, P. W. (1994). A simple and efficient procedure for non-isotopic in situ hybridization to sectioned material. *Trends Genet* 10, 75-6.

Swain, A. and Lovell-Badge, R. (1999). Mammalian sex determination: a molecular drama. *Genes Dev* 13, 755-67.

Swain, A., Narvaez, V., Burgoyne, P., Camerino, G. and Lovell-Badge, R. (1998). Dax1 antagonizes Sry action in mammalian sex determination. *Nature* 391, 761-7.

Swain, A., Zanaria, E., Hacker, A., Lovell-Badge, R. and Camerino, G. (1996). Mouse *Dax1* expression is consistent with a role in sex determination as well as in adrenal and hypothalamus function. *Nature Genetics* 12, 404-409.

Takasaki, N., McIsaac, R. and Dean, J. (2000). Gpbox (Psx2), a homeobox gene preferentially expressed in female germ cells at the onset of sexual dimorphism in mice. *Dev Biol* 223, 181-93.

Talts, J. F., Eng, H., Zhang, H. Y., Faissner, A. and Ekblom, P. (1997). Characterization of monoclonal antibodies against tenascin-C: no apparent effect on kidney development in vitro. *Int J Dev Biol* 41, 39-48.

Tilmann, C. and Capel, B. (1999a). Mesonephric cell migration induces testis cord formation and Sertoli cell differentiation in the mammalian gonad. *Development* 126, 2883-90.

Tilmann, C. and Capel, B. (1999b). Mesonephric cell migration induces testis cord formation and sertoli cell differentiation in the mammalian gonad [In Process Citation]. *Development* 126, 2883-90.

Tsai, F. Y., Keller, G., Kuo, F. C., Weiss, M., Chen, J., Rosenblatt, M., Alt, F. W. and Orkin, S. H. (1994). An early haematopoietic defect in mice lacking the transcription factor GATA-2. *Nature* 371, 221-6.

Tung, P. S. and Fritz, I. B. (1987). Morphogenetic restructuring and formation of basement membranes by Sertoli cells and testis peritubular cells in co-culture: inhibition of the morphogenetic cascade by cyclic AMP derivatives and by blocking direct cell contact. *Dev Biol* 120, 139-53.

Tung, P. S., Skinner, M. K. and Fritz, I. B. (1984). Cooperativity between Sertoli cells and peritubular myoid cells in the formation of the basal lamina in the seminiferous tubule. *Ann N Y Acad Sci* 438, 435-46.

Vainio, S., Heikkila, M., Kispert, A., Chin, N. and McMahon, A. P. (1999). Female development in mammals is regulated by Wnt-4 signalling [In Process Citation]. *Nature* 397, 405-9.

Vidal, V. P., Chaboissier, M. C., de Rooij, D. G. and Schedl, A. (2001). Sox9 induces testis development in XX transgenic mice. *Nat Genet* 28, 216-7.

Vilain, E. (2002). Anomalies of human sexual development: clinical aspects and genetic analysis. *Novartis Found Symp* 244, 43-53; discussion 53-6, 79-85, 253-7.

Wagner, T., Wirth, J., Meyer, J., Zabel, B., Held, M., Zimmer, J., Pasantès, J., Bricarelli, F. D., Keutel, J., Hustert, E. et al. (1994). Autosomal sex reversal and campomelic dysplasia are caused by mutations in and around the SRY-related gene SOX9. *Cell* 79, 1111-20.

Yao, H. H. and Capel, B. (2002). Disruption of testis cords by cyclopamine or forskolin reveals independent cellular pathways in testis organogenesis. *Dev Biol* 246, 356-65.

Yao, H. H., DiNapoli, L. and Capel, B. (2003). Meiotic germ cells antagonize mesonephric cell migration and testis cord formation in mouse gonads. *Development* 130, 5895-902.

Yao, H. H., Matzuk, M. M., Jorgez, C. J., Menke, D. B., Page, D. C., Swain, A. and Capel, B. (2004). Follistatin operates downstream of Wnt4 in mammalian ovary organogenesis. *Dev Dyn* 230, 210-5.

Yao, H. H., Whoriskey, W. and Capel, B. (2002). Desert Hedgehog/Patched 1 signaling specifies fetal Leydig cell fate in testis organogenesis. *Genes Dev* 16, 1433-40.

Zhou, Y., Lim, K. C., Onodera, K., Takahashi, S., Ohta, J., Minegishi, N., Tsai, F. Y., Orkin, S. H., Yamamoto, M. and Engel, J. D. (1998). Rescue of the embryonic lethal hematopoietic defect reveals a critical role for GATA-2 in urogenital development. *Embo J* 17, 6689-700.

Publications arising from this work

Pam Siggers, Lee Smith, Andy Greenfield. (2002). Sexually dimorphic expression of *Gata2* during mouse gonad development. *Mech Dev* 111, 159-162.

Grimmond S, Van Hateren N, Siggers P, Arkell R, Larder R, Soares M. B, de Fatima Bonaldo, Smith L, Tymoska-Lalanne Z, Well C et al. (2000). Sexually dimorphic expression of protease nexin-1 and vanin-1 in the developing mouse gonad prior to overt differentiation suggests a role in mammalian sexual development. *Hum Mol Genet* 9, 1553-60.

Appendix A: PCR primer details

Primer Name	Sequence (5'-3')	Annealing temp	Product size bp	Notes
T3	AATTAACCCTCACTAAAGGG	50	-	Seq
T7	GTAATACGACTCACTATAGG GC	50	-	Seq
HPRTA	CCTGCTGGATTACATTAAAGC ACTG	56		RT-PCR control
HPRTB	GTCAAGGGCATATCCAACAA CAAAC	56	352	RT-PCR control
OCT4F	CTCAGCCTTAAGAACATGTG	56		W ^e /W ^e RT-PCR
OCT4R	TTACTCTTGTCTACCTCCCTT	56	563	W ^e /W ^e RT-PCR
VnnFRT	TGGGGAGTTTCAGGTGTCAA	56		W ^e /W ^e RT-PCR
VnnRRT	GTAATCTATCTTATGATGG	56	500	W ^e /W ^e RT-PCR
Vnn1F	TTGCTGCTGTCGTTGGACTTC	68		1 st exon
VnnR1	CTGCTTCGCTGCAGATACGA	68	196	1 st exon
LACZNF	CGTTGGAGTGACGGCAGTTA	55		Transgenic typing
LACZNR	CGCAGGCTTCTGCTTCAATC	55	418	Transgenic typing
Vnn3F	CACAGGCAGCTGGCTGGCAT	55		RT-PCR
Vnn3R	TTCCTCTCACTTGCTTTGCC	55	1819	RT-PCR
KOneo	CGAATTCGCCAATGACAAGACG	55		Null typing
5'KOend	GTTCTCCAATCCCAAAGTGC	55		Null typing
3'KOend	ATTGATTCACCACTCAATCCCTG	55		Null typing
Ube1yF	CTCTGAGTACATCCGTGG	60		XO typing
Ube1yR	GCAATCCTGCTGAACTGC	60	500	XO typing

Appendix B: Control riboprobe details

Name	Origin	Accession #	Vector	Antisense
<i>Sox 9</i>	Gift P.Koopman	BC004064	pBluescript II sk	BamH1/T7
<i>Oct 4</i>	IMAGE consortium	AA522407	pBluescript II sk	BamH1/T7
<i>3βHSD</i>	IMAGE consortium	AI323693	pT7T3D- Pac1	EcoR1/T3
<i>Ptc-1</i>	IMAGE consortium	BF719201	pT7T3D- Pac1	EcoR1/T3
<i>Dhh</i>	IMAGE consortium	BE137145	pT7T3D- Pac1	EcoR1/T3
<i>Sccl</i>	Isolated from NIA/Oligo screen	NM_019779	pSport	Sal1/Sp6

Appendix C: Transgenic PCR genotyping results

Tail #	Date of birth	Sex	Transgenic	Notes
9	13/02/01	F		
10		F		
11		F		
12		M		
13		M		
14		M		
15		M		
16		M		
17		M	+ LacZ	FOUNDER
18	06/03/01	F		
19		F		
20		F		
21		F		
22		M		
23		M		
24	21/03/01	F		
25		F		

26		F		
27		F		
28		F		
29		M		
30	20/07/01	F		
31		F		
32		F		
33		F	+	Progeny P17
34		F	+	Progeny P17
35		M	+	Progeny P17
36		M		
37		M	+	Progeny P17
38		M	+	Progeny P17
39	30/08/01	F		
40		F		
41		F		
42		F		
43		F		
44		M		
45		M		
46		M		

47		M		
48		M		
49		M		
50		M		
51	24/09/01	F		
52		F		
53		F		
54		F		
55		M		
56		M		
57		M		
58		M		
59		M		
60		M		
61	02/10/01	F		
62		F		
63		F		
64		F		
65		F		
66		F		
67		F		

68		M		
69		M		
70	10/10/01	F		
71		F		
72		F		
73		F		
74		F		
75		M		
76		M		
77		M		
78		M		
79		M		
80		M		
92	21/10/02	F		
93		F		
94		F		
95		F		
96		F		
97		F		
98		F		
99		M		

100		M		
101		M		
102	06/02/02	F	+LacZ	FOUNDER
103		F		
104		F		
105		M		
106		M	+LacZ	FOUNDER
107		M	+LacZ	FOUNDER
109	11/02/02	M		
110		M		
111		M		
113	08/04/02	F	+LacZ	Progeny P102
114		F		
115		M		
116		M		
117		M	+LacZ	Progeny P102
118		F		
119		F		
120		F		
121		F		
122		M	+LacZ	Progeny P107

123		M		
124	07/04/02	F	+LacZ	Progeny P106
125		F		
126		F	+LacZ	Progeny P106
127		F		
128		M		
129		M	+LacZ	Progeny P106
130	11/04/02	F	+LacZ	Progeny P106
131		F	+LacZ	Progeny P106
132		F		
133		M	+LacZ	Progeny P106

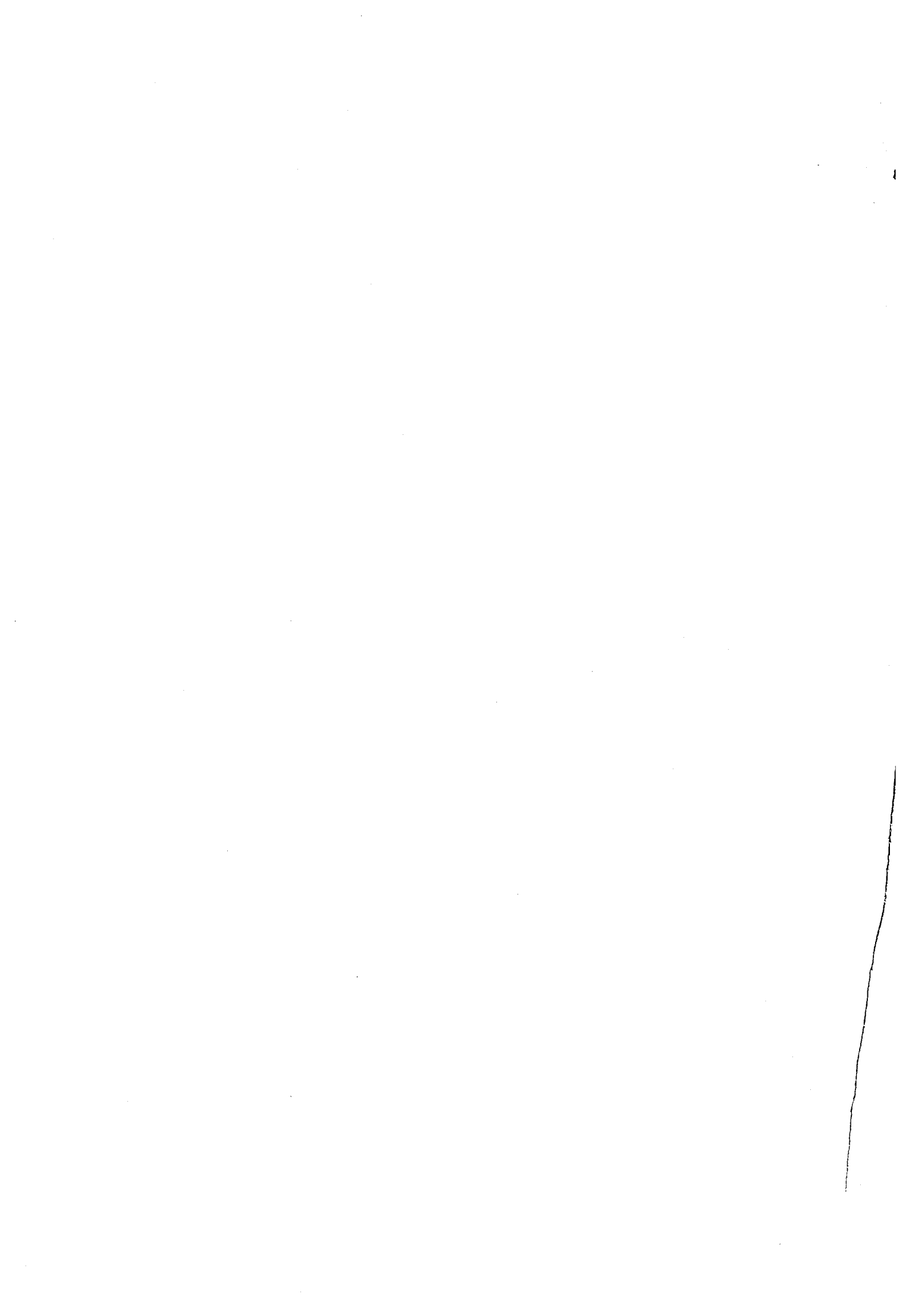

Appendix D C3H/HeH inter-cross genotyping results

Embryos were collected at 13.5 dpc. The sex was determined by the detection of Barr bodies in the amnion and genotyping was performed by PCR. A 350 bp band alone indicates -/- mice and a 120 bp band alone indicates wild type mice; mice containing both products are heterozygous for the mutation (B). Currently, no testes have been found which genotyped as -/- for Vanin-1 (A). Adult inter-cross mice generated from further matings were also genotyped and Vanin-1-/- males were identified (C).

LITTER	GONAD	SEX BY AMNION PREP	GENOTYPE PCR
ICA 1	TESTIS	X	+/+
ICA 2	OVARY	XX	+/-
ICA 3	OVARY	XX	-/-
ICA 4	OVARY	XX	-/-
ICA 5	OVARY	XX	+/-
ICA 6	OVARY	XX	+/-
ICA 7	OVARY	XX	+/+
ICB 1	OVARY	XX	-/-
ICB 2	OVARY	XX	-/-
ICB 3	OVARY	XX	+/-
ICB 4	OVARY	XX	+/+
ICB 5	TESTIS	X	+/-
ICB 6	TESTIS	X	+/-
ICB 7	OVARY	XX	+/-
ICB 8	TESTIS	X	+/+
ICB 9	OVARY	XX	-/-
ICC 1	OVARY	XX	+/-
ICC 2	TESTIS	X	+/-
ICC 3	OVARY	XX	-/-
ICC 4	TESTIS	X	+/-
ICC 5	TESTIS	X	+/-

A

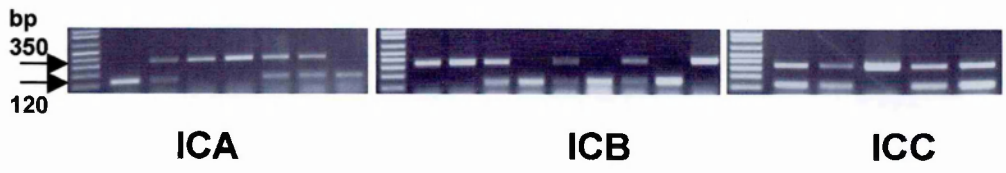

B

Genotype PCR	+/+	+/-	-/-
Female	5	12	5
Male	6	5	5

C

I