

The Curriculum Design and Approval Process at the University of Strathclyde

Baseline of processes and curriculum design activities

Project Information			
Project Acronym	PiP		
Project Title	Principles in Patterns		
Start Date	1 September 2008	End Date	31 May 2012
Lead Institution	University of Strathclyde		
Project Director	David Nicol and Diane McDonald		
Project Manager and contact details	Catherine Owen, Centre for Academic Practice and Learning Enhancement, University of Strathclyde		
Partner Institutions			
Project Web URL	www.principlesinpatterns.ac.uk		
Programme Name (and number)	Institutional Approaches to Curriculum Design		
Programme Manager	Sarah Knight		

Document Name			
Document Title	The Curriculum Design and Approval Process at the University of Strathclyde - An Initial Process Mapping		
Reporting Period			
Author(s) and project role	The PiP Project Team		
Date	30/09/09	Filename	Curriculum Design and Approval Process
URL			
Access	<input checked="" type="checkbox"/> Project and JISC internal	<input type="checkbox"/> General dissemination	

Document History		
Version	Date	Comments
v. 2	30/09/2009	Revised in line with feedback from programme team

Contents:

1. Introduction
2. Institutional strategic context
3. The Curriculum Approval process for Modules and Programmes
4. The Curriculum Design Process
5. Opportunities for enhancement
6. Beneficiaries of change

1. Introduction

The objectives of the Principles in Patterns (www.principlesinpatterns.ac.uk) project are to:

- ❑ Document current practice in faculty curriculum design and approval processes with an emphasis on identifying gaps and blockages in planning processes, in information sharing, in the way guidance is provided and in alignment with strategic objectives.
- ❑ Develop a new approach to curriculum design and approval that reduces blockages, more appropriately supports staff and reflects the principles and strategic objectives embodied in University policy.
- ❑ Test out ways of representing effective learning designs at task, module and course (programme) level to support teachers in design activities and to support staff members responsible for planning, managing and sharing of curriculum design information.
- ❑ Represent these outputs in ways that are useful to other institutions engaged in curriculum design and to the wider HE and FE sector.
(project plan p5)

This baseline document provides a review of current institutional processes and practices in relation to curriculum design within the University of Strathclyde. It provides baseline information about the module and programme decision-making process and the associated documentation flow. Issues, bottlenecks and challenges raised by current practices are highlighted. This document also reviews current support for learning design and for the representation and sharing of good designs at the University of Strathclyde and discusses how design might be improved. We did not attempt to baseline design practice per se, as that would be a major research project in its own right.

2. Institutional strategic context

The University of Strathclyde is currently undergoing significant change in its strategic focus and in its management structures and processes. A new Principal has been appointed and his vision is that the University of Strathclyde becomes a world recognised technological university building on its strengths in science, engineering, in business and in social sciences applications. The faculties and the University's professional services are being restructured and new decision-making procedures and processes are being implemented. The university wishes to reduce inefficiencies in decision-making processes across the institution, to strengthen research, links to business and to local communities while at the same time developing an international profile with respect to staff and student recruitment.

The University of Strathclyde is also developing a new educational strategy while at the same time building on its long-term strategic work to enhance the quality of student learning. A number of strategies and policies already focus on the student learning experience; these include a programme of activities (i) to support first year learning and socialisation – all students should have group working experiences in year one (ii) to support student transition (e.g. from school to university, from first year to later years, from

undergraduate to postgraduate) (iii) to enhance assessment and feedback (e.g. through initiatives to encourage departments to apply the assessment and feedback principles approved by Senate in 2008 (iii) to identify and raise awareness about the attributes required by 21st century graduates and developed through study at Strathclyde. The graduate attributes focus is recent and will be strengthened in the new educational strategy. The University has also recently restructured its curricula so that they adhere to a 20-credit framework for all modules (called classes at Strathclyde).

The baseline data that has been collected must be interpreted in the light of the above shifting landscape. Certainly, the changes that might be made to support curriculum design will have to fit with the University's new and developing vision and with the vision that will be embedded in the new educational strategy.

3. The Curriculum Approval Process for Modules and Programmes

The process base-lining explores approval processes in relation to modules (classes) and programmes (courses). A baseline is provided of current approval processes and of the associated document flow. Issues, bottlenecks and challenges in the current process are also identified.

Methodology

Respondents

An iterative interview and reflection approach was used to review of current approval documentation. This involved discussions with the following members of staff (respondents) at the University of Strathclyde:

- members of the Governance, Management and Policy Team with particular responsibility for the approval process
- Faculty Officers
- Dean and Vice Dean
- Academics engaged in developing programme and module proposals

PiP team members also met with staff in the core support areas of Registry, Estates, Library and Information Services were, Disability Services to discuss their involvement in the approval process.

Phases of base-lining

The process base-lining involved six phases:

1. review of all policy and guidance material available at the University and faculty levels
2. develop an initial outline sketch of the processes.
3. carry out one-to-one interviews with respondents to elicit their understanding of the whole process
4. capture the process as described by the documentation and respondents in structured diagrams

5. re-interview respondents using the new diagrams as the focus for discussion in order to:
 - verify that the diagram was an accurate reflection of their description,
 - elicit their comments on and (ideally) agreement on the elements added and edited on the initial diagrams in response to other respondents' insights
 - elicit further reflections on issues and bottlenecks in reaction to seeing the process as a formal diagram
6. develop formal diagrams that represent the process

The Diagrams of the Process

During the research phases, diagrams were prepared using a simple informal flowchart style. These were simple to produce and were easy for users to understand. At the final stage of the process base-lining activities the diagrams were consolidated into more formal diagrams using Business Process Modelling Notation (BPMN).¹

BPMN was chosen because of its explicit focus on process and ability to represent complex processes with a small range of symbols. It also successfully captures actors and roles (through pools or *swimlanes*) without distracting from the central process flow. The diagrams produced are generally self-explanatory to novice readers without the need to explain the meaning of the symbols used. The notation also allowed for a measure of validation. As there is no intention to translate the BPMN representation into a functioning BPEL system the degree of validation was limited to checking the syntax of the diagram, however even at this level it was useful to identify gaps in the model, e.g. paths that did not lead to a conclusion. The notation can also be used as an aid to identify weaknesses in the process flow and for modelling improvements, although this was not relevant to the initial base-lining exercise.

A caveat

The process base-lining activity began by exploring the approval processes of both modules and programmes together as respondents initially indicated that there was significant commonality between the two processes, e.g. both were considered at the same meetings by the same committees. During the reflective iteration of the base-lining interviews some respondents pointed out the differences between the programme and module approval processes, the programme process being more complex, and suggested that the two process diagrams be separated out. As this suggestion came late in the base-lining process, a separate programme diagram has not yet been prepared. The diagrams here are therefore validated representations of the module approval process. For the purposes of the PiP project the module-centric process model provides a solid foundation for the core work of project.

The Approval Process

University of Strathclyde policy states that new programmes and modules, and changes to existing programmes and modules must be recommended by the relevant Faculty Board of study and approved by Senate. A Faculty Board recommendation should follow a period of

¹ <http://www.bpmn.org/>. The diagrams were developed using version 1.2 notation, but would be valid under version 2.

scrutiny by the appropriate Faculty Committees in accordance with university procedures and guidelines. When a Faculty Board of Study is satisfied with its own internal scrutiny of the robustness and appropriateness of new programmes/modules or any amendments to existing curriculum then a Module Descriptor Form (modules) and/or Programme Specification (programmes) is prepared and a summary document sent to Senate for approval.²

At present, the university does not prescribe a detailed format for programme or module proposals, leaving each faculty to create its own documentation. Guidance is provided, and most documents contain similar information.

Diagram Overview

The diagram in Appendix 1 represents the approval process from initiation of a new proposal in the host department through to its approval and inclusion in the University Course Catalogue. While it does capture feedback paths triggered when a proposal is rejected at any of the decision points, it does not include any of the review and enhancements processes that are triggered after the module or programmes has been delivered.

The core diagram identifies six *pools* which represent a distinct group of actors;

1. Department
2. Faculty
3. Registry
4. Senior Committees, as although the committees operate independently their role in the approval process appears as a single role thanks to the high level of coordination provided by the committee officers
5. Secretariat, represented as a distinct pool from the Senior Committees to express their role as the institutional administration
6. Marketing, represented as a single pool although comprised of several different units within the University structure as the part played by these actors is essentially post approval

The process flows across the six pools as a single sequence, however six phases can be identified.

Phase 1, Initiation

The approval process begins in the departments. The processes that ultimately lead to a programme or module being submitted for approval vary considerably both between and within departments. This base-lining exercise has not sought to catalogue these alternatives nor assess their prevalence. The common feature of these various processes is that they all result in, and arguably centre around, the preparation of a faculty programme specification or module descriptor.

² The terminology used across the University for these two levels varies; even within the current documentation. A project is currently underway within the Governance, Management and Policy Team to review the documentation and standardise the terminology. For the purposes of the PiP Project we have used the terms *programme* and *module* as we have found these to be the most widely understood both within and outwith the University, if not the most widely used.

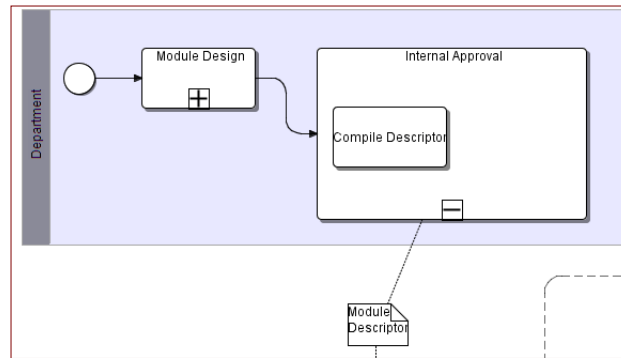

A guiding insight of the PiP Project is that it is this concrete expression of the programme/module design that acts to shape not only the representation of the pedagogical design but also the pedagogy itself through the questions asked and the messages sent.

Phase 2, Faculty committee approval

The heart of the approval process is arguably the faculty level scrutiny undertaken by the undergraduate and postgraduate studies committees and, to a lesser extent, the Faculty Board.

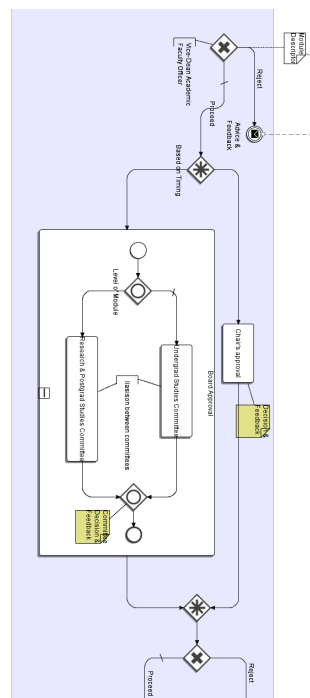

From a process modelling perspective an interesting feature of this section of the diagram is the "complex gateway" that appears after the initial evaluation by Vice Dean Academic and Faculty Officer. The choice, whether a proposal should proceed to "Chair's Approval" or the faculty committees, is a complex one depending on many factors. The main determining factor is, as the diagram notes 'timing', with Chair's Approval used when proposals are in danger missing the window for consideration by the Faculty Board or Senate. However, other factors also bear on

the decision, such as the contentiousness (or lack thereof) of the proposal, or whether this is a new proposal or one being submitted again after responding to the conditions and advice accompanying a previous rejection.

The selection of committee to evaluate the proposal is typically a straightforward one, although some proposals are presented to both committees. The committees are the last point in the process where the proposal is evaluated on the basis of the full programme specification or module descriptor. From this point forward committees are presented with a summary or compilation of proposals.

At this stage of the process, and in subsequent stages, the decision is either to endorse the proposal's progression to the next stage or for it to be sent back to the department. This is expressed in the model as a message event with "Advice and conditions" send back to the department. The way this is communicated to departments and how departments react to this communication varies from department to department. Where the required revisions have been completed at the department level the proposal re-enters the process moving through the same sequence again.

Phase 3, Faculty Board and other actors

Approval by the faculty studies committees sees the process begin to diverge as information about the proposal is passed to other actors as well as to the Faculty Board.

Again the "complex gateway" has been used to express the separation of the process paths, however in this case the complexity derives from the asynchronism of the paths. All three paths should be activated by the committee approval, however the paths do not necessarily converge at a later stage in the process (as is expected in BPMN). Furthermore it is possible that one path, the Resources and Planning Committee path may not be activated, at least from experience in the Faculty of Law Arts and Social Sciences. Respondents suggest that other faculties may include their Resources and Planning Committees at an earlier stage in the process, if only to give agreement in principle, although this is largely for programme proposals.

It is at this stage that Registry brought into the process. A form is sent to request a course code for the proposed course.

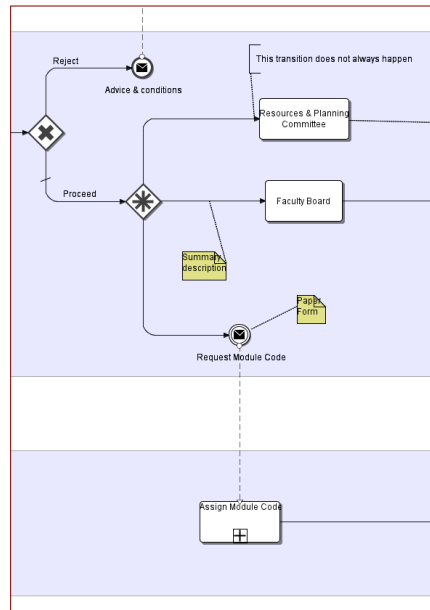

Phase 4, Faculty Board to Senate

If the proposal is accepted by the Faculty Board a summary is prepared for Senate. Upon approval by the Senate the proposal will move to a final scrutiny by the Ordinances and Regulations Committee.

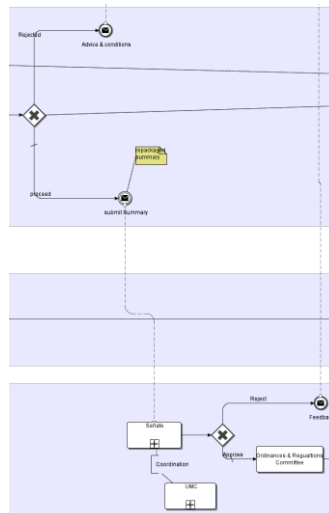

Phase 5, Ordinances and Regulations Committee

Final approval by the Ordinances and Regulations Committee results in the proposal being officially accepted by the University. Its approval triggers a number of actions by Registry and the marketing functions. However, faculties and departments currently manage their own websites and other publicity so that it is possible that programme and module information may be available through these outlets before the formal approval process is complete even though they will not appear in the University course catalogue etc.

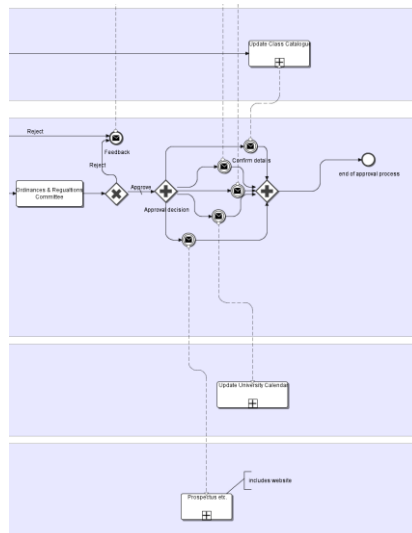

Phase 6, Delivery

Following approval by the Ordinances and Regulations Committee and inclusion in the University Course Catalogue the module is available for delivery. Respondents indicated, however, that there are instances where the department or faculty is committed to delivering a module and may have begun to form classes even before the final stage is completed. Similarly there are also instances where a module may not be delivered or even offered after approval.

Issues arising from baselining of approval processes

During the course of the interviews respondents identified a number of issues thrown up by the operation of the current process. These observations were augmented by the findings of other consultations that have taken place across the institution both formal and informal. In capturing the issues raised we have sought to identify those which were both intrinsic to the current process and which were particularly relevant to the PiP Project. Furthermore, while all respondents raised many issues, those included in the process base-lining were ones that were articulated by several respondents. Three themes emerged - issues relating to the process flow, issues surrounding the document workflow, and those issues that are particularly relevant to the work of the PiP Project.

Process flow issues

Most of the issues relating to the process flow concerned timing, in particular the bottlenecks caused by the scheduling of the meetings of committees where decisions were made. Respondents identified that the last Senate and Ordinances and Regulations Committee meetings to make approval decisions on the coming semester's courses delivered decisions too late for the modules and programmes to be available to prospective students to easily find and register for them, and faculty officers reported that arrangements were in place to direct students to local sources of information rather than the central Course Catalogue. Arguably, departments and faculties could have targeted earlier meetings of the committees to ensure that the approval came in time.

Flowing from the lateness of the approval were issues reported related to the support functions such as the Library, Disability Service and Estates. In each case respondents identified problems caused when their area was informed of new modules too late to allow a proper response.

An approach adopted to overcome the inflexibility of the committee timetable that respondents identified was the practice of submitting proposals that were incomplete or which were expected to be returned for amendments in order to get the proposal into the process flow. However, as the process is predicated on a full scrutiny of complete proposals this tactic results in proposals being examined that the proposer knows will be rejected.

The linear structure of the approval process also throws up issues. Without a strong feedback loop respondents reported that the proposal as ultimately approved might have deviated from the initial proposal during the approval process, but that these changes and amendments were not always communicated back to the department and in particular were not communicated back to the academic staff delivering the module.

Document workflow issues

The current process is based on MS Word documents created from templates which are moved through the process primarily by email and on paper. Each faculty has its own variations on the forms as each collects additional information, beyond that which is required by the central administration. All of the respondents who commented on this aspect of the process found the current process unsatisfactory.

Most of the issues raised ultimately rested on the absence of any version control mechanism. For example there is no common unique identifier for a proposal, even after a course code has been requested. The result is considerable effort on the part of administrative staff to reconcile divergent versions, an effort that is increased when elements of the proposal can change through the process including the title of the proposed module or programme.

Problems of version control are exacerbated by the absence of any central repository of approved descriptors, let alone proposals. Thus full descriptors as approved at the faculty and Senate level are not easily available as a source of reference. Not only is this an issue when amended proposals are reintroduced to the approval process, it also means that reviewers cannot easily see how a module will contribute to the programme(s) it is a part of. The lack of a central repository of approved descriptors is also an issue when modules and programmes are reviewed.

The absence of version control and repository of proposals is a problem when proposals are resubmitted, particularly when the resubmission is in response to the conditions set by a committee. In practice there is no straightforward way for committee secretaries to prepare documentation in a way that highlights those changes that have been made in response to the advice and conditions that accompanied an earlier rejection.

Issues of particular relevance to the PiP Project

All the issues identified in the process flow and especially those arising from the document workflow have a bearing on the PiP Project. However, it is the educational strategy and pedagogical issues that are of principal interest. A prime motivator behind the project is the disjunction between the educational policies adopted by the University and the education delivered through the programmes and modules offered. The approval process is one of the points of intersection between policy and design where not only should the approval bodies be able to see evidence of the translation of policy into pedagogy but should also offer an opportunity to support academics designing programmes and modules and enable them to better embed the policies into their practice. From this perspective the current process is failing to achieve its potential impact and this is reflected in the issues raised by respondents.

When reflecting from the point of view of the approval committees, respondents expressed concern that the descriptors and the descriptor summaries presented to the committees did not capture information on the educational design that would allow the committee to make an informed assessment of the extent to which a module or programme might embody the educational policies and priorities of the University or faculty. Even where questions did address aspects germane to the policy, respondents expressed frustration that often the answers provided did not provide enough information.

However, those designing modules expressed a different concern, the lack of support and information. Policy and best practice guidance is scattered across many different sources and is only rarely presented in a way that explains how the policy and best practice might be embedded into a programme or module design. There are several ways in which these messages are transmitted to academics, most obviously through the work of the Centre for Academic Practice and Learning Enhancement, but also initiatives at a faculty level. However these rarely target the design process specifically and the guidance that accompanies descriptor forms typically concentrates on the bureaucratic and administrative requirements rather than only the translation of policy into effective curriculum designs.

Respondents also mentioned inflexibility and sheer size of the forms as an issue. The current forms, even though they do not adequately address questions of educational policy and pedagogy, were found to be daunting and onerous to complete. Indeed the current forms and approval process were reported as being a barrier to pedagogical innovation rather than an enabler and a driver for improvement. In the Faculty of Law Arts and Social Sciences new forms were piloted that did ask an extended range of questions that were intended to elicit more information on pedagogy and to stimulate designers to consider their learning design in more detail. The results of the pilot were felt to be disappointing as the pedagogical enhancements were not widely achieved and the extended form was not welcomed.

The systems being developed through the PiP project are intended to address the apparent contradictions between the imperative to collect more and better information for reviewers about the embedding of educational policies and principles, the desire to support and encourage designers in embedding these principles, and the need to make the design and proposal writing process as straightforward and accessible as possible avoiding the overload

that designers currently experience. The system models being developed should not only help to reconcile these competing concerns but also to address the issues of document control, versioning and retention, which will in turn alleviate many of the process flow issues highlighted in the process base-lining.

4. The Curriculum Design Process

This section discusses the design process from the point of view of an academic or group of academics designing teaching and learning. It provides a baseline of the current support available at the University of Strathclyde for learning design and a baseline analysis of how learning designs are represented (documented). It ends with a discussion of the design issues and the possible enhancements to design support. This section and earlier sections by necessity overlap.

Learning Design

The core activity of curriculum design occurs when disciplinary experts formulate design plans for the teaching, learning and assessment activities. Design plans are formulated at different levels – e.g. the design of learning tasks to be implemented within a class (module), the design of the whole module (class) or the design of a course (programme). Many aspects of design are however tacit (they exist only in the minds of the designer) and only some of the design outputs are documented.

A complex mix of factors might influence design and documentation activities:

- ❑ Prior experience as a student and teacher
- ❑ The pedagogical orientation and skills of the teacher
- ❑ The educational objectives (or intended learning outcomes) of the module or programme as written down in documentation.
- ❑ External drivers (e.g. developments in subject matter, professional requirements)
- ❑ Institutional, faculty and departmental policies and strategies
- ❑ Processes and procedures embodied in planning, documentation, approval and quality assurance.
- ❑ Resource constraints such as availability of teaching rooms, online technologies etc.
- ❑ The market for the course
- ❑ The educational support available to academic staff tasked with design (e.g. from CAPLE)
- ❑ The motivation to utilise the available educational support within departments and faculties.

Despite this list of potential influences, it is unlikely that designers hold all these factors in mind when designing educational experiences for students. Some may have more salience than others and some may only be considered after the design is produced.

The Tables, 1, 2 and 3 below bring together some of the elements that directly influence curriculum design. The Tables portray design at three levels because these are different – learning task design as it might occur within the teaching of a module, module design refers

to the design of all the elements that comprise the module and programme design which refers to the design of a whole undergraduate degree comprising a series of modules.

The Tables identify the stakeholders at each level, highlight what we know about the design process, about the way designs are documented (represented) and about the available support for design at the University of Strathclyde. The columns issues and enhancement identify respectively some design issues and what might be done if we were to enhance the design process institutionally.

	PROCESSES How do academics design?	REPRESENTATIONS Where is the information about design documented?	SUPPORT What support for design is available?	ISSUES What are the issues?	ENHANCEMENT How can we enhance design? (suggestions)
<p>TASKS</p> <p>Internal stakeholders:</p> <p>Academic staff Students Support staff e.g. IT (for some tasks) Educational developers</p> <p>External stakeholders:</p> <p>Employers/some community partners (e.g. when tasks involve external activities)</p>	<ul style="list-style-type: none"> Design process is not explicit, more often it is based on disciplinary conventions, traditions and the prior experience of staff, either as teachers or as students Explicitness is more apparent in assessment expressed through coursework tasks. Some task designs might be guided by implicit pedagogical models (e.g. PBL) Design is influenced by student numbers, equipment, available rooms and by perception of students' needs/abilities 	<ul style="list-style-type: none"> Previous course implementations in lecturer's own notes and those of other staff. Many tasks repeated year on year and formalised into protocols (e.g. field-trips, lab sessions) and in homework exercises. Student handbooks will give information about what students expected to do 	<ul style="list-style-type: none"> University has developed guiding principles of assessment and feedback. CAPLE runs a three-day course with session on design. Advanced academic studies module on course design CAPLE offers consultancy to departments and faculties Case examples of tasks documented in REAP example 	<ul style="list-style-type: none"> Almost no research on how academics design tasks, about how internal procedures and external factors influence design. Process is tacit. Teachers' skills/beliefs may support or hamper good design. Task design is probably dependent (to a large extent) on disciplinary context. No consistent pedagogy in place. No 'systematic' institutional support. Task design must be considered in the context of module design.(coherence) Formalised representations might constrain rather than support enhancement. New technologies add complexity to design process. 	<ul style="list-style-type: none"> Ask relevant educational questions about tasks in module forms (P) Help academics produce designs consistent with pedagogical principles (e.g. assessment principles) or values in educational strategy. Provide task design models (online) across the disciplines. Create tools to support task design. Enhance CAPLE support on learning task design

	PROCESSES How do academics design?	REPRESENTATIONS Where is the information about design documented?	SUPPORT What support for design is available?	ISSUES What are the issues?	ENHANCEMENT How can we enhance design?
<p>MODULES</p> <p>Internal stakeholders:</p> <p>Academic staff Students Heads of Department Faculty Officer(s) Registry, IT Services, Estates, Library and other services Educational developers</p> <p>External stakeholders:</p> <p>Employers Community stakeholders</p>	<ul style="list-style-type: none"> Design process is not explicit but draws on prior experience and conventions. For example, in Social Sciences lectures, tutorials and essay writing is a common design pattern. In Science it might be lectures, labs and problem-solving classes Where a team delivers there might be team discussion about module design and delivery Design influences include: feedback from students on previous iterations/similar modules, resource availability including staffing and teaching accommodation. External drivers (e.g. professional requirements) and internal procedures (e.g. documentation) may influence design. 	<ul style="list-style-type: none"> Module approval and review process at department and faculty levels although different in different faculties. Module description forms. Documents produced for professional bodies. Review forms represent evaluations and might highlight successful features. Student handbooks 	<ul style="list-style-type: none"> University has developed guiding principles of assessment & feedback Established staff help new staff to design modules. Benchmark statements in the disciplines Professional body requirements. Departmental reviews. CAPLE provides session in 3 day course on design and a course design module in AAS programme. CAPLE offers consultancy to departments to support module design Materials from REAP Benchmark statements in the disciplines. Professional body requirements 	<ul style="list-style-type: none"> Lack of knowledge about how external drivers and internal procedures and policies influence module design. How forms and processes relate to University educational strategy is not explicit. Approval and review forms do not necessarily ask appropriate educational questions about design (e.g. how students will practice skills or get feedback). Diversity of forms across the faculties. Different people often responsible for design and delivery. Representations often traditional and innovation difficult to transfer Different stakeholders need different types of information about modules Room bookings and library support not coordinated to design. Student handbooks may not highlight the rationale behind designs. 	<ul style="list-style-type: none"> Investigate how academic staff currently design. Align approval and review forms to good design – ask appropriate questions Raise faculty officers awareness about design Provide models of good module design (RS) Collate case examples of good design from across the University and from research (RS) Link design to university educational policies (e.g. assessment & feedback, the educational strategy) Enhance staff development support for redesign Help students understand design and their role in it (online resources).

	PROCESSES How do academics design?	REPRESENTATIONS Where is the information about design documented?	SUPPORT What support for design is available?	ISSUES What are the issues?	ENHANCEMENT How can we enhance design?
<p>PROGRAMMES</p> <p>Internal stakeholders:</p> <p>Academic staff Students Course leader(s) Quality Officers Programme Co-ordinators Registry, IT Services, Estates, Library and other services Heads of Department Faculty Officer(s) Dean University Management Committee (UMC)</p> <p>External stakeholders:</p> <p>Employers Professional bodies Community stakeholders</p>	<ul style="list-style-type: none"> • Design process is not explicit and like modules draws on prior experience and conventions. • Programme design involves the bringing together of module design in some disciplines (e.g. Social Sciences) but is more coordinated in others (e.g. Chemical Engineering). • Team discussions about programme design more likely than with modules. • Potential design influences include external requirements (e.g. professional bodies, NSS results) and internal procedures (documentation) and policies and findings (retention data). • Design influenced by staff skill and expertises 	<ul style="list-style-type: none"> • Programme approval and review process at department and faculty level • Internal programme specification forms • Prospectus • Handbooks • University strategies (goals, type of institution) helps to define the programme mix) 	<ul style="list-style-type: none"> • QAA programme specifications • QAA subject benchmarking statements • Professional body guidelines/ requirements • CAPLE consultancy for departmental teams – not common practice in past • CAPLE workshops at module level informative at programme level • Departmental reviews of teaching and learning 	<ul style="list-style-type: none"> • Module leaders may focus on their own modules in isolation • Linking module design and programme design is complex • Articulating programme-wide considerations like student progression is complex – are the same teaching methods used in year one, two and three? • Programme coherence is dependent on modules (e.g. different philosophies might give mixed messages) • Programme level learning outcomes might not inform module level outcomes • More coherent programme planning might constrain student choice 	<ul style="list-style-type: none"> • Key questions on programme forms – e.g. about progression (P) • Streamlining of documentation flow and sharing. • Models of good programme design • Case examples from research • Systematic redesign support for departmental teams • Redesign support for course leaders

How do academics design?

Not much research has been carried out on how academics design tasks, modules and programmes. Anecdotal evidence suggests that a great deal of design activity is tacit. New lecturers tend to draw on their own experience as students, on disciplinary traditions and conventions and on advice they might get from colleagues in departments. Many do not need to actually design tasks or module early in their careers and are more likely to be delivering a module (with prescribed tasks) designed by a colleague, although they will have more latitude for task design within module offerings.

Patterns of module design tend to get repeated from year to year. For example, in Social Sciences it is common that the module comprises a series of lectures, tutorials or seminars assessed through essay writing activities. Business school courses include lectures, tutorials and essay writing but their might also be reports and presentations. In Science lectures, labs and problem solving classes are common.

Programme design is the sum of a number of module designs in some disciplines with the overall programme content dependent to some extent on the expertise of the academic staff (e.g. in social sciences). The teaching and learning methods however are more likely to be influenced by departmental traditions and professional requirements. Recent evidence suggests that when the goals of programmes are explicitly used by lecturers to frame the design of individual modules students report a more coherent learning experience (Gibbs, 2008). However, this is not an explicit practice across the disciplines.

Issues

Given the lack of research on the educational design process questions about how to support better design are very important. Many tools have been developed through JISC funding but there are questions about whether they actually build on prior experience in design by practising academics and about whether they are too complex to support new staff to become better designers. For example, helping staff develop the skills to engage in learning task design is fundamental. At the same time raising awareness about the bigger picture of the context of the task in the module and the module in the programme is also important in terms of curriculum coherence (see below). If we knew how staff currently think through design it might be easier to develop tools that would enhance design.

How design is represented in documentation at the University of Strathclyde

Task representation

University documentation does not require that information about task design be explicitly documented. This contrasts with representations for module and programme design. However, the documentation of learning task design does occur in a variety of ways. There is often reference to learning tasks in student handbooks (you will write an essay, solve these problems, you will come to the class prepared to discuss this topic). Also, many learning tasks are repeated year-on-year and formalised through protocols (e.g. lab sessions, field trips, group projects, the discussions in seminars and tutorials). Learning task design is also represented in the notes and handouts that lecturers use to prepare for and

deliver a class (e.g. in groups do this, questions for a PRS class session) and in homework exercises.

Module representation

The documentation for module design (called a class at Strathclyde) is more systematic and explicit than task design as modules have to be approved and their delivery is reviewed at departmental and faculty committees (see section 3 for full details).

At present, each faculty at the University of Strathclyde uses locally-generated **module descriptor forms** to support the module approval process). The layout and content of the forms differ across faculties, but there are a number of generic similarities in what is required as follows:

- Module title
- Credit value and level of study³
- Educational aims
- Learning outcomes⁴
- Module format (e.g. no of lectures, lab sessions, seminars, tutorials)
- Contact hours
- Syllabus (or module content)
- Assessment methods (% breakdown of marks and the duration of exams)
- Main text books/reading list

As well as the module descriptor form there is also a different type of representation of the module in student handbooks where they are produced and in module websites within virtual learning environments.

Every year lecturers are required to provide information to the faculty as part of the review of module delivery. So far, baseline data on this process has not been reviewed but it might be important as a locus for enhancement activities and this will be investigated through the PiP project.

Programme (course) representation

Programme design is also explicitly documented at the University of Strathclyde in a similar way to module design. The key document is the 'Programme Specification', which is a requirement of all University programmes. This summarises the main features of a programme in terms of:

- overall aims of programme
- intended learning outcomes including personal/transferable/key skills
- programme structure
- learning and assessment methods
- calibration of programme against the Scottish Credit and Qualifications Framework

³ During 2008/09 the University of Strathclyde has moved to a universal 20 credit module structure to comply with the requirements of the Scottish Credit Qualifications Framework (SCQF). The majority of modules should comply, but there are likely to be some variants. Justification for any variance will be a component of the module descriptor form.

⁴ A description of the intended learning outcomes for modules is a requirement of the SCQF.

- calibration against subject benchmarking information
- student admission, progression and learning support
- arrangements for programme evaluation and review.

[the reader should note that more work is required to baseline programme representation across the University of Strathclyde]

Issues

Task representation: A key question here is whether there should be greater documentation and sharing of learning task designs than currently exists. Enhancing the focus on learning tasks would encourage academic staff to think about what their students will do, what activities they will engage in, rather than only on what they themselves will do. This is likely to result in a more learning-centred rather than teaching-centred curriculum. It will also lead to curricular offerings that are more consistent with what is known from theories of learning (i.e. that what the student does in learning is more important than what the teacher does). If task design were documented it would also be possible to share good practice across the institution. [It should be noted that in this discussion we have not defined what constitutes a learning task (e.g. what level of granularity is appropriate) except to note that a module would comprise a number of learning tasks].

University Strategy: A second issue concerns how current module descriptor and programme specification link designs to University and Faculty strategies. Examining the scope of the headings above (these headings would normally be formulated as questions) it is clear that these documents result in a limited range of responses. For example, the current module and programme approval documentation provides little or no opportunity to show how the module or programme aligns with institutional strategies or policies including the Academic Strategy⁵ or the University's guidelines on assessment (which are critical to good design). There is also little or no opportunity within module descriptor forms to demonstrate alignment with locally-generated policies (for example, faculty or departmental strategies). Programme specifications⁶ are similarly devoid of references to faculty or department strategies.

Emphasis on delivery: The module descriptor forms also do not ask questions about critical educational processes required to support learning that will be instantiated in the design. For example, they do not ask how students will get practice in key skills and how they will get feedback during a module. There is an over-emphasis on the delivered elements of the programme (or, "what the teacher does") rather than considering what students are being asked to do and how this relates to their overall learning experience. For example, the module approval documentation does not ask how learning outcomes are related to activities and how those activities help to build student competences. Similarly, whilst

⁵ See:

<http://www.strath.ac.uk/media/departments/administrativedepartments/secretariat/governancemanagementandpolicyteam/academicaffairs/Academic%20Strategy%20-%20interim%20update%20-%20Apr%2008.pdf>

⁶ For examples, see: <http://www.mis.strath.ac.uk/Secretariat/Publications/general/programme-specs/index.html>

module descriptor forms include information about summative assessment, there is no requirement to describe how module activities contribute to formative learning processes.

Programme coherence: The current module approval process requires some information about how the module will fit into the programme of study. This information is supplied on a separate form and details the level of study, the pre-requisite and co-requisite entry requirements for students and how the module feeds into subsequent modules as a pre-requisite in programme progression. However, there are no sections of the forms that ask how the module might support student transition, skills or competence development, or progression within the context of the overall programme. Many aspects of the student learning experience are best designed with the totality of the programme in mind. For example, PDP is most effectively implemented as a progressive element of modules from the first year onwards. Other strategies, including assessment, benefit from coherent planning across the programme to ensure that they support development of desirable student attributes (for example, self-regulated learners).

Diversity of information provided: As well as the administrative challenges posed by the diversity of forms used for module approval across the institution, there is considerable diversity in the way forms are used and completed. Even when the information sought is broadly consistent, there can be considerable divergence in the amount of detail provided. Similar diversity is in evidence at programme level. This can create difficulties for administrative staff in central service units (for example, Registry) creating standardised information resources, including the prospectus, for students and other stakeholders.

Roles and responsibilities: It is not always clear who has overall responsibility within departments for overseeing the design, description, production and delivery of modules and programmes. Administrative responsibility for the production of documentation seems to rest with Faculty Officers, but it is unclear whether they also play a substantive role in advising on and monitoring the academic coherence of programmes, although in some departments the Faculty Officers are key sources of information of educational development. There is also anecdotal evidence that academics involved in the design of modules in one year are often poorly informed about the detail of provision in later years of study.

Enhancement of the educational experience: The University of Strathclyde has taken an active role in the development of QAA Scotland's Enhancement Themes.⁷ Evidence of engagement with the outcomes of these themes is an increasingly important component of the Enhancement-led Institutional Review (ELIR) conducted by QAA Scotland. The ELIR processes looks for indicators of innovation in areas including assessment, employability, student transition, flexible delivery and research-teaching linkages. Some evidence of progress in these areas is evidenced through activities delivered at module or programme level. At present, in the module and programme approval processes there is not opportunity to evidence activities in these areas and there is no requirement to state how modules or programmes might be aligned to the aspirations detailed in the Enhancement Themes.

⁷ See: <http://www.enhancementthemes.ac.uk/>

Other issues

- ❑ Student handbooks may not highlight for students the rationale behind learning designs in modules and what they might be expected to get out of participating in them.
- ❑ Internal stakeholders may not be able to derive the information they need to create their own documentation (schools and colleges liaison services)
- ❑ Design information might not reach relevant stakeholders in a timely manner.

Support for Curriculum Design at the University of Strathclyde

There are various kinds of support for learning design available at the University of Strathclyde. Firstly, there is documentation produced by the sector to help academics in the disciplines frame their designs. These are embodied in the stated requirements of professional bodies, in subject benchmark statements and in QAA documentation, for example, on assessment and feedback (e.g. their published precepts of good practice). Secondly, there is documentation available regarding University values and objectives for teaching and learning. For example, the current educational strategy emphasises the need to develop in students the ability to monitor and manage their own learning, to provide group working for all students in the first year etc. The University has also approved a set of 12 assessment and feedback principles (derived from the REAP project). This policy also contains examples of how these principles have been implemented in practice across different disciplines. A third source of design support is case examples of good practice although most of these are at the task level rather than the whole module level although there are exceptions (e.g. module examples derived from REAP project). A fourth source of support for design is available through the work of the Centre for Academic Practice and Learning Enhancement (CAPLE). This Centre offers workshops on task design and module design and has recently been working with whole departments on programme design. It also offers an accredited module on teaching, learning and assessment and another module on task and module design. In the latter, participants work on the design of a module that will normally be implemented: this might be a face-to-face module, a blended module or a fully online module. Fifthly, CAPLE offers consultancy to departments wishing to design a module or programme.

Notwithstanding all the support available, most academics learn to design through participating peripherally within communities of practice before becoming practitioners themselves. In reality most new lecturers do not have to design when they begin their university teaching career. They enter the department and are allocated teaching by established staff. There are patterns and protocols for this teaching already in place (lectures, tutorials, problem solving classes) and the experienced staff are able to provide some guidance and advice. Over time new lecturers become established and they perpetuate the methods they have acquired as part of the ways of doing things in that disciplinary culture. Some academics are highly innovative, both experienced and new staff,

but we do not know exactly what the drivers for innovation are. However, experience in CAPLE has shown that external drivers (e.g. the NSS) and rewards and incentives for teaching innovation and design support all play a part in fuelling innovation.

Issues

- ❑ How to produce representations of task, module and programme designs in ways that are accessible and understandable to academic staff. In REAP this proved a major issue but some success was evidenced when we represented designs in relation to the assessment and feedback principles that they instantiated. The more principles that were evidenced in a single design the more likely it was a powerful design example. Also, highlighting the principles behind designs helped academics develop the skills to design learning activities for their own module context.
- ❑ We do not fully understand how professional body requirements or subject benchmarking or QAA documentation influence curriculum design
- ❑ Academic staff may not use CAPLE support and there is no requirement that they must do so.
- ❑ Case studies of design are often too complex and often take too much time to understand
- ❑ New technologies have added to the complexity of curriculum design

Opportunities for enhancement

Revised module descriptor and programme specification forms

The university has expressed a commitment to revision of the module descriptor and programme specification forms to:

- ❑ Create one coherent set of forms for use by all faculties/departments
- ❑ Better address the information needs of a variety of stakeholders (e.g. Registry, Estates, Marketing etc)
- ❑ More effectively monitor the influence of key institutional policies and statutory requirements (e.g. employability, disability etc.)
- ❑ Encourage and support enhancement of the student learning experience through linking approval forms to resources that would support learning design activities.

New forms might will do one or more of the following:

- ❑ Ask different questions about the student learning experience and about how the module relates to University aspirations embodied in strategies.
- ❑ Ask questions about the ways in which modules fit together to create coherent programmes (questions may be included on both module descriptor and programme specification forms)
- ❑ Ask questions about university policies and statutory requirements (e.g. how disabled students are supported)
- ❑ Be more prescriptive in the way that modules and programmes are described in order to support more efficient re-purposing of data (e.g. for the prospectus etc.)
- ❑ Be online and accessible in real time to a larger number of stakeholders with edit rights.

However it should be noted that decisions will have to be made about the amount of information collected on approval forms. A balance will have to be struck between making the information collected more relevant and useful while at the same time not overburdening academic staff who will have to fill out these forms.

The PiP team will develop an online system for module and programme documentation and approval that will offer a number benefits:

- ❑ Standardisation as well as differences easy to manage where required
- ❑ Easier to input, edit and view data
- ❑ A number of different people can access, edit and take responsibility for data
- ❑ Easier to re-purpose data for different uses
- ❑ Potential to automatically monitor some processes

Changes to the forms will require new working practices and/or approaches to curriculum design (for example, increased collaboration in designing modules that will be delivered as part of the same programme). The forms need to signal the university's aspirations whilst reflecting the real life working practices of departments and recognising that changes to working practices take time to secure.

Support for Design

Support linked to approval process: A difficulty with a majority of existing support resources is that they are situated outside the normal working practice of most academic staff in relation to module and programme approval. Current support materials include case studies, exemplar designs, principles of good design etc. By changing the module and programme approval process to ask more searching questions about educational design, this might stimulate demand for targeted information about good design practice. This information will be made available online and presented in an integrated way with links from the revised module and programme documentation forms.

Principles in patterns: The intention in PiP is to provide initially a range of resources for staff and students centred around the university's 12 assessment and feedback principles. These principles have been derived from the REAP work and their value has already been evidenced in 19 modules. The principles also underpin the academic strategy as they are intended to support the development of learner self-regulation. We have already created a leaflet to explain to staff that the University takes feedback on learning seriously and that it is creating resources online to support better practice. These resources will comprise a range of learning design examples linked to the assessment and feedback principles, a frequently asked questions section on feedback with examples of good practice and links to a whole range of external resources on feedback on other websites and journal articles. All the examples are tied to the assessment principles as this is the underpinning representation of good design. As the university develops a clear set of wider principles to underpin its new educational strategy we will extend the website resources to show how courses might be designed to support 'internationalisation' and the development of important graduate attributes.

Resources for students: A parallel set of resources are being created for students to help them better understand assessment and feedback processes and learning design. We have created a leaflet for students on feedback underpinned by the University's assessment and feedback principles and are building a set of online resources for students so that they can proactively take a more active role in making feedback work even if their lecturers do not emphasise this through their own teaching practice.

Workshops for departments: We will use the PiP funding to test out processes that will help departments utilise the online resources being developed. We will document these processes and refine them as a resource for other institutions that wish to run similar events for staff to improve the design of feedback. As we did with REAP, when we work with an academic or a group of academics we will take some learning patterns (based on principles) to them and work with them to adapt the patterns to their context. This will establish their benefit and might lead to variants that might also be collected and shared.

Beneficiaries of change

Students

Students are the intended beneficiaries of all learning enhancement activities. This project does not extend to monitoring the effectiveness of curriculum designs in their delivery stages or their impact on student learning. However, the project does seek to influence student experiences by:

- ❑ Creating information and support resources for students. Effective learning is not a passive activity and good learning designs emphasise active participation. Students need to understand design and how they should approach learning in order to get the most benefit from well-designed curricula. Leaflets and web resources are currently being created for students.
- ❑ Encouraging greater student participation in design decisions. One important message is how to involve students more actively in aspects of the design process. Ideas about how to do this will also be signalled through the resources created or academic staff.

Academic staff

The PiP project will support academic staff by:

- ❑ Creating improved design opportunities through departmental and faculty approval processes. The creation of new documentation (module and programme approval forms) should offer opportunities for more informed discussion within departments and faculties about good design.
- ❑ Creating an information-rich environment that links good design practice to known problems. Information resources for staff members may take a variety of forms, but they are likely to offer targeted solutions for common issues (e.g. how to give feedback to large groups of students, how to create opportunities for students to practice key skills etc.)
- ❑ Using principles to inform good design. This will be done using the University's 12 assessment and feedback principles agreed by Senate in the first instance. Over the next 6 months the University will develop a revised strategy. It should be easy to

develop a new set of principles that capture the key ideas in that strategy and use these to further refine the module and programme approval processes.

- ❑ Develop a set of workshop processes to enable departments to review their curriculum designs. This work has already started in some departments and some process protocols for workshops to support learning design have already been documented.

Department/faculty decision makers and administrators

Departmental administrators and committee members are asked to make decisions on the validity of modules and programmes, but at present they do always receive useful information about how strategies are being translated into curricular offerings or to identify examples of good practice that might be worth sharing across the institution. The PiP project will:

- ❑ Support the creation of better documentation to inform decision-making on how modules and programmes are implementing key ideas from strategy and to pick up on enhancements.
- ❑ Support resources for departmental and faculty re-design activities will also be developed (for example, information on how to run a re-design workshop –see above)

University decision makers and administrators

Better documentation will provide enhanced opportunity for the university to monitor and support uptake of educational policies (for example, the assessment policy) and to create better information for prospective students (e.g. in the prospectus and other marketing materials). There is potential to create efficiencies in the institutional reviews undertaken by QAA Scotland, for example the ELIR (Enhancement Led Institutional Review) process, by creating better information about high quality educational provision.