

Dynamic Capabilities and Internet of Things as Predictors of Supply Chain Performance in Thailand: Mediating Role of Operational Agility

Natnaporn Aeknarajindawat*¹

¹ Graduate School, Suan Sunandha Rajabhat University, Bangkok, Thailand

*Corresponding author: Natnaporn.ae@ssru.a.th

Abstract— Manufacturing sector is largely relying on its supply chain performance to bring efficiency in production in terms of cost and time. Internet of Things (IOT) and Dynamic Data and Information Processing Capabilities (DDIPCs) are found as strong predictors of organizational agility which can probably play part in supply chain performance. Use of IOT and DDIPCs basically enhance flexibility in organizational operations resulting in their smooth functioning. So, this study has tried to analyze the impact of use of IOT and DDIPCs on supply chain performance of manufacturing sector in Thailand in mediating role of organizational agility. Around 67 organizations have been used as sampling frame as data has been collected from their employees through questionnaire-based survey which was subsequently analyzed through SPSS and AMOS by applying tests of CFA and SEM. Hypotheses testing has concluded that both use of IOT and DDIPCs significantly increase supply chain performance through direct and indirect paths. Organizational agility has been also found as significant mediator in respective relationship. Originality in this study lies in association between use of IOT and DDIPCs with supply chain performance which was not tested before. This study has its implications and future research indications too.

Key Words: Supply Chain Performance, Use of Internet of Things, Dynamic Data and Information Processing Capabilities and Organizational Agility

1. Introduction

Supply chain involves all the people, processes and activities that are used to develop a new product starting from the supply of raw materials from suppliers to the manufacture of the product for the end customer [1]. The part of supply chain that provides the product from manufacturer to customer

is called distribution channel [30]. To better manage a supply chain, it is very important to have complete information about all the factors involved the manufacture of product from raw materials to its final form. When all these parts of a supply chain work in collaboration with each other in the manufacture of product, it will increase the supply chain performance [2]. This performance is not owned by a single person; instead the whole force involved in the supply chain process is responsible for supply chain performance [31; 35].

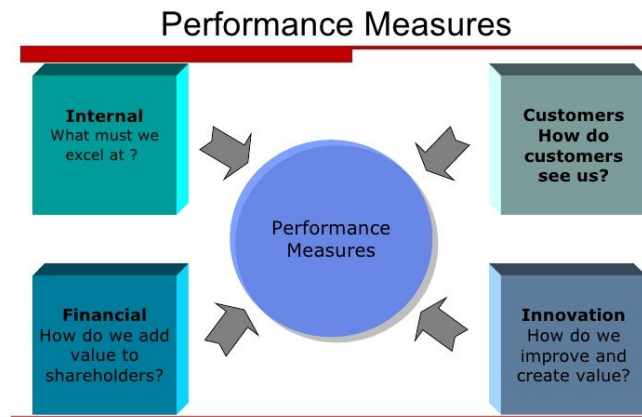

Figure 1: Performance Measures

Figure 1 shows different measures of performance of a supply chain. Innovation includes the use of new technology such as IoT. Internet of things IoT refers to the devices that can be connected with each other for the purpose of communication of information. It is the advanced form of regular computers and web and is more efficient in its work [3]. It is considered as revolution in communication and information technology [32]. IoT is very useful as it communicates data with speed and accuracy between different actors involved in any organization. This leads to a better business operations involved in any business [4]. It can help businesses in the tracking of resources, manufacturing operations, challenges in any firm and coordination with other organizations. In Thailand, firms are taking interest in IoT adoption and it is expected that they will shift their businesses over this technology soon [5].

Any organization's dynamic capabilities involve the ways in which it adopts any change in market and how it processes any information or data involved in that business. These capabilities process data in such a way that it becomes very easy to use it in business operations [6]. To answer customer queries, this capability is used for the purpose of increase in customer satisfaction. Use of IoT is also an important aspect in this regard, in which the businesses having newer technologies are able to process information and data in a better and more professional way, which ultimately improves their business operations and supply chain performance.

Operational agility of any organization depicts that how it responds to different changes in business

environment [7]. Quick, accurate and cost efficient responses are in favor of any organization to run its processes smoothly. It is the ability to respond both internal and external changes in the business world. It can be assumed by its name that it is basically involved with the operations of organization [8, 9]. If any evident change takes place in internal or external business environment, an organization make certain changes in its operations to cope with those changes resulting in its better results. Four dimensions of operational agility are very important for both internal and external environments i.e. speed, accuracy, cost efficiency and flexibility.

IoT adoption and the improvement of dynamic capabilities of information and data processing can increase the operational agility of any organization, which in return improves the supply chain performance, but sad to say that, IoT adoption and dynamic capabilities are not that much improved in Thailand, due to which it becomes difficult to respond to unexpected changes that occur in business world [10]. This incapability to not properly address to these changes leads to the low performance of supply chains. Along with Thailand, other developing and under developed countries are also facing the same issues of low supply chain performance. If this situation prevails longer, the actors involved in the supply chain i.e. suppliers, distributors, costumers etc. will be highly unsatisfied which is not in any interest of an organization [11]. So it is very important to adopt IoT and improve organization's capability to process data in information professionally, so that the operations of any

organization have better agility that leads to improved supply chain performance. Many studies have been done to study all the indicators of supply chain performance [33-34] and fewer studies in order to study the impact of IoT adoption and dynamic capabilities on supply chain performance [12]. But no research has been conducted to study the mediating role of operational agility between the above-mentioned variables. A research paper, thus has recommended studying the mediating role of operational agility between IoT and dynamic capabilities, and supplying chain performance [13]. The main objectives of this research can be listed as:

- Analyze the significant impact of IoT adoption on supply chain performance in firms of Thailand
- Analyze the significant impact of dynamic capabilities of data and information processing on supply chain performance in firms of Thailand
- Analyze the mediating role of operational agility between IoT adoption and supply chain performance in firms of Thailand

2. Literature review

2.1. Theory of Constraints

The internet of things relates its abilities and capabilities to the dynamic data and information processing systems (DDIPS). There are certain promising things that link one variable to another through operational agility and dynamic data collection. IOT [17] emerges as a key disrupted technology that play main role in daily activities. In the information management literature, the term 'things' and 'agility' generally consists of three dimensions operational, partnering and customers that focuses on the productivity of business performance. Network connectivity and ability to send and receive data through communication, is normally considered as a function of IOT. IOT [18] enables the use of smart app devices that enhances visibility, leading to the development of agile operations among connected business network. Operational agility focuses on quick responses, accurate actions, and cost efficiency [19], however studies believe that operational agility is not effected by external processing systems neither it is only relatable to internal processing systems. It basically

- Analyze the mediating role of operational agility between dynamic capabilities of data and information processing and supply chain performance in firms of Thailand

Thailand is increasing the use of IoT in its business sector for better and faster transfer of information. Costumers and business sectors are working together on this project and are getting successful in this purpose [14]. This has led to better supply chain performances in Thailand and its growth rate is expected to be 3% to 4% in the future as big investments are expected. Coming towards the significance, theoretically, many researches have been done to show the impact of using modern technology on business performances [15]. Practically, these researches have helped the business sector of Thailand to adopt new technology of IoT and improve their dynamic capabilities. Govt. is also supporting this adoption by making its access easy and making technology friendly policies [16].

acts as e device that has the ability to easily react to sudden changes and uncertainties. However, it provides opportunities to increase the level of performance through developing reliable network partners that assist in identifying knowledge, problems and capturing opportunities to improve their performance. Practical and theoretical [20] steps that are needed to become an agile manufacturer through an implementation of theory of constraints practices, empirical evidences and conceptual framework to promote the idea of operational agility along with IOT capabilities and dynamic predictions. RBV and SME also supports the theoretical framework related to theory of constraints [21] that acts as a responsible catalyst for creating an agile manufacturer despite the effect of lean production environment within a firm or business performance. Customer learning can emphasize the application of theory of constraints in assisting the identification of problems, difficulties and challenges. This theory also supports the supply chains related to integration, performance, management or customer that highlights the function of logistics processing. Agility basically includes demand responses, customer

responses and joint planning. Operational agility [22] can be used in many functions of network enterprises like recovery, collaboration and partnership. Redesigning and rebuilding of dynamic capabilities and supply chain performance ultimately enables the exploitation of market orientation opportunities that are the basic and effective part of external business environment.

1) Use of Internet of Things and its relationship with supply chain performance

IOT and supply chain performance (SCP) [2] are interconnected due to the involvement of theory of constraints that develops a constant platform for external business processing as well as internal business processing. IOT capability has a strong influence on the effectiveness of operational performance along with SCP that largely focuses on speed, assertiveness, accuracy, cost-efficiency and flexibility. IOT associates itself with computing facilities and sensors. These devices that use IOT provide accurate and real-time data [23] and information for communication and sharing purposes. SCP enhances visibility same like operational agility that promotes the effectiveness of response operations in terms of the accountability of resources. IOT capabilities has a positive impact on SCP that can be clearly shown by the performance of agility between the two variables, which develops a connection between the terms through bringing accuracy, competitiveness and affectivity [24] in the process of product creation moreover, through assessment of situation and resource allocation. IOT works in a stable environment because it lacks responding to a rapidly changing market as well as environment. To introduce a flexible system of business and enterprises constraints theory initiates the development process of IOT capabilities within SCP [1] environment for the purpose of supporting lean manufacturing skills along with agile characteristics that are needed to act responsively and adaptively to effectively handle IOT functions and wide spreading of network. Agility enhances the practices of IOT network by providing suitable smooth environment which further promotes SCP in a manufacturing sector. However, certain practical approaches are used regarding the application of TOC perspective that embellishes the position of an agile manufacturer in a small firm or a large firm.

Though, due to business revolution along with industrial revolution IOT is considered as an important digital tool that can bring revolution to the modern technology in a modern era. Thus, the following hypothesis is proposed that:

H1: Use of Internet of things has a significant impact on supply chain performance.

2) Dynamic Data and Information processing capabilities relationship with Supply chain performance

Dynamic data and information processing capabilities DDIPC has a significant effect on the development of SCP with the revolution of modern technology that promotes the development of IOT network in different business sectors and departments, to make convenience for communication, sharing knowledge, learning through lean manufacturer, and gaining competitive advantage which will eventually cause an increase in supply chain performance along with supply chain management. Theory of constraints extract the phenomenon of dynamic data building according to the theoretical perspectives of past literature that enhances the value of SCP under the circumstances of flexibility, accessibility, effectiveness of performance and in promoting modern day business as well as business processing. Due to these characteristics of DDIPC [25] it builds better connectivity and progressive operations to improve the supply chain agilities which will further enhance the productivity level of the products. Dynamic capabilities are considered as imperative for contemporary data-driven business operations but somehow, it is also responsible for keeping data safe while it improves business network visibility, flexibility, performance and operational agility for the sake of SCP that will run according to the values, demands and requirement of IOT network. Operational agility utilizes individual speech recognition capabilities that will speed up the warfare operations, in order to speed up the function of DDIPC related to agilities therefore; it will fasten the production and performance of supply chain under the criteria of agility and competitive advantages. Thus, the following hypothesis is proposed that:

H2: DDIPC has a significant impact on supply chain performance

3) Mediating Role of Operational Agility between Internet of things and Supply chain performance

As per study's [20] authors believe that operational agility works for the benefit of IOT network which promotes the concept of supply chain performance. Theory of constraints develops an idea that through the use of internet and digital oriented technology, companies are however transferring their vital and timely information to their international and global networks partner, so that they can utilize the resources used in IOT network that will perhaps increase the demand of product through gradual customer orientation, driving supply chain performance to high level of management abilities along with the handling of data capabilities. Its an advice for different companies who wants to share their information with other companies at the global level in which IOT plays a significant role in facilitating communication and particularly exchange of data and knowledge between certain entities, showing the performance of agility and supply chain beyond borders at international platform. IT or IOT devices and technology is used for the improvement of both internal and external operational agilities which further improves the quality capability related to IOT and SCP. Operational agility has the potential to generate depth, height and breadth of knowledge which basically enhance the performance of supply chain along with IOT operational network. Thus, the following hypothesis is proposed that:

H3: Operational agility has a significant mediating role between the relationship of use of Internet of things and Supply chain performance.

4) Mediating Role of Operational Agility between Dynamic data and information processing capabilities and SCP

Studies [26] elaborate the empirical analyses which include the approaches and strategies regarding the implementation of operational agility which facilitates the conceptual effect of DDIPC along with the function of SCP within the business environment. Theory of constraints clearly depicts the knowledge and idea related to the performance of dynamics of data as well as associating the data collection with the information processing capabilities that utilizes the operational factors furthermore, it also utilizes the operational circumstances to gain benefit from operational agilities via business operations, manufacturing, distribution and transportation of products and services, along with the allocation of natural reserves and cultural business environment resources. Developing data and its dynamics are currently associated with the modern world that inherits capabilities which can easily assist both customers and supply networks including SCP. Data collection shared or stored can be of different types like as heterogeneous data that are generated by the devices connected with the IOT's and their organizations need to process and store efficiently. Modern business organizations are molding itself in such a way that it easily get access to the IOT devices and advanced IT infrastructure which will rather improves the dynamic data capabilities along with information processing capabilities that will further improves the effectiveness of SCP. Thus, the following hypothesis is proposed that:

H4: Operational agility has a significant mediating role between the relationship of DDIPC and SCP.

Model:

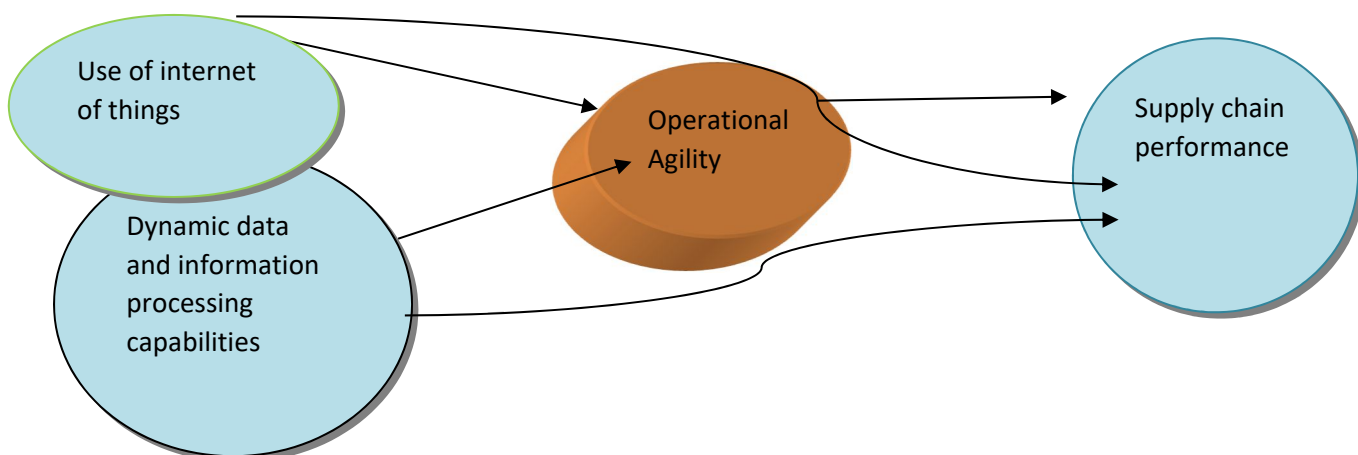

3. Research Methodology

3.1. Population and Sampling

Researcher has been conducted this study in order to examine how the supply chain performance predicted by dynamic information processing capabilities and internet of things, in mediating role of the operational agility. For this research, target population has been selected is manufacturing sector of Thailand because most of the manufacturing industries incorporate the internet of things and dynamic capabilities in their supply chain. Researcher has been selected automotive and electronic manufacturing industries because supply chain performance of parts manufacturers has been increased by incorporating dynamic information processing capabilities and IoT in operations. Further, managerial employees have been selected as respondents by using purposive sampling techniques because if the employees rapidly adopted the IoT and dynamic capabilities then they can lead the high performance of the supply chain. Coming towards sample size, it has been selected on the bases of idea represented by (Klein, 2015) which states that formula such as number of questions*10 provide accurate sample size. Researcher has been selected 300 sample size after the calculation, questionnaire has been distributed among the 300 respondents.

Data Collection Techniques

Structured questionnaire has been used by researcher in this research study. Questionnaire has been composed of four parts. In first part, researcher asked about demographic information and in second part, researcher asked about impact of dynamic capabilities and IoT on supply chain performance. As far as third part is concerned, researcher asked about the how operational agility play mediating role in independent and dependent variable and fourth part is about whether the supply chain performance improved or not. Researcher has to ensure the content validity of scale by industrial practitioner. Online and self-administered questionnaire techniques have been used by researcher in order to collect the data.

3.2. Analysis of Reliability, Validity and Common Bias

SPSS has been used to assess reliability and criteria to examine this states that Cronbach's α has to be greater than 0.70 (Chin, 1998) because its

values were strong at above 0.70. Further, AMOS has been used to assess validity but criteria to examine that are different for convergent and discriminant validity. For convergent validity, three criteria have been which includes (1) items loading (λ) and its threshold range is greater than 0.70, (2) composite constructs reliability and its values must have to exceed specific limit 0.80 and (3) average variance extracted must have to be greater than 0.50. Coming towards discriminant validity, its values must have to exceed when correlated with all other constructs.

Common bias has been originated when respondent of this study used same measures to evaluate the variables which he or she has been provided for explanatory variables by common rater (Donaldson & Grant-Vallone, 2002; Podsakoff, MacKenzie, Lee, & Podsakoff, 2003). Every study has some variations due to the addition of new variables, so as with this study which includes set of variables such as dynamic capabilities, internet of things, operational agility and supply chain performance which must have evaluated differently. In order to control the risk of common bias method, researcher has been used Harman's single factor test which has been administered with exploratory factor analysis and confirmatory factor analysis. In EFA approach, researcher checked whether most of constructs accounted for by single factor or not. Results reported that different has been used for accounting of constructs. 92% of variance has been interpreted by factor solution and 23% of variance interpreted by single factor. CFA approach has been used in order to confirm the absence of risk of common bias method.

3.3. Hypothesis Testing

Hypothesis testing has been done through structure equation modeling (SEM) which has been run on AMOS. In order to run the diagnostics of SEM, AMOS used covariance-based approach. So, in this study researcher test the multiple hypotheses such as impact of dynamic capabilities and internet of things on supply chain performance in mediating role of operational agility. Acceptance or rejection status of hypotheses has been verified through their significance and t-statistics value. Moreover, direct, indirect and total effect has also been used in order to

checked whether hypotheses relationship accepted or not accepted.

3.4. Measures

UIoTs was measured with the scale developed by Lorenzo (2000), with the help of five items that were taken on a five-point Likert scale. Then DDIPCs were assessed by the scale developed by the researcher

4. Empirical Findings

The impact of UIoT and DDIPCs on supply chain performance (SCP) was analyzed along with the mediation of operational agility by running SEM in AMOS however, the descriptive analysis, convergent validity, discriminant validity, and CFA were applied before running SEM on the data.

4.1. Demographic Analysis

The demographics of respondents revealed that 52.9 percent of them were females while 47.1 percent of them were males. The educational level of 49.1 percent respondents was post-graduation and education of 37.9 percent respondents was "Masters". 10.2 percent respondents were having degree of

Nonako & Nagata (2001) and here four items were taken on a five-point Likert scale and were assessed. OA was measured by a scale developed by Huo (2001), four items were taken and measured on a five-point Likert scale. Finally, SCP was measured by the scale developed by Zhao Rai (1998) and five items were taken which were measured on a five-point Likert scale.

graduation while 2.7 percent respondents were having other educational degrees. The demographic factor of age was also analyzed which revealed that 80.2 percent of total respondents were of age between 21 and 30 years while 14.3 percent of respondents were of age between 31 and 40 years. The age ranging from 41 to 50 years was accounted by 3.1 percent of respondents only while the least number of respondents were having age more than 50 years.

4.2. Descriptive and Suitability Analysis

The results of table 1 are indicating the descriptive characteristics of all variables in which the mean value, minimum value, maximum value, std. deviation, and skewness against UIoT, DDIPCs, OA and SCP have been provided.

Table 1. Descriptive Statistics

	N	Minimum	Maximum	Mean	Std. Deviation	Skewness	
	Statistic	Statistic	Statistic	Statistic	Statistic	Statistic	Std. Error
UIoT	293	1.00	4.90	3.6000	1.05833	-.886	.142
OA	293	1.00	5.00	3.5154	1.12718	-.645	.142
SCP	293	1.00	5.75	3.4036	1.04638	-.288	.142
DDIPCs	293	1.00	5.00	3.4625	1.11294	-.570	.142

The mean value of UIoT, DDIPCs, OA and SCP are all falling between minimum value and maximum value thus showing absence of any outlier or extreme value in their data. The standard deviation is also indicating that there is not too much variation in the

data. Furthermore, the values of skewness in the data of UIoT, DDIPCs, OA and SCP are all more than -1 and less than +1 so, the current data is normal, acceptable and adequate. The KMO test further proved the suitability of the data.

Table 2. KMO and Bartlett's Test

Kaiser-Meyer-Olkin Measure of Sampling Adequacy.		.924
	Approx. Chi-Square	11119.780
Bartlett's Test of Sphericity	Df	435
	Sig.	.000

The value of KMO for the current data is 0.92 which is definitely greater than 0.6 so, the current data is proved to be suitable for further analysis.

4.3. Convergent and discriminant validity

The convergent validity and discriminant validity of the current data were checked through AVE, MSV, CR and correlations. Table 3 indicates the results of convergent and discriminant validity.

Table 3. Convergent and discriminant validity

	CR	AVE	MSV	MaxR(H)	OA	UIoT	DDIPCs	SCP
OA	0.948	0.790	0.347	0.969	0.889			
UIoT	0.966	0.742	0.347	0.984	0.589	0.861		
DDIPCs	0.936	0.780	0.476	0.990	0.391	0.521	0.883	
SCP	0.894	0.678	0.476	0.991	0.408	0.580	0.690	0.824

It has been revealed through results of table 3 that CR for OA, UIOT, DDIPCs and SCP is 0.94, 0.966, 0.94 and 0.89 respectively so, the data and scales of these variables are reliable. Furthermore, the values of AVE for all of them are >0.5 that are indicating the discriminant validity of the data. The MSV of OA, UIOT, DDIPCs and SCP less than their respective AVEs are further proving the discriminant and convergent validity. The correlation of each variable with itself is the higher than its correlation with any

other variable so, the convergent validity is also confirmed.

4.4. Model Fitness

The fitness of the current model was assessed through CFA in which the key indicators were found regarding the current model. The values found against each indicator and their threshold ranges have been provided in table 4.

Table 4. CFA

Indicators	Threshold range	Current values
CMIN/DF	Less or equal 3	2.450
GFI	Equal or greater .80	.828
CFI	Equal or greater .90	.949
IFI	Equal or greater .90	.949
RMSEA	Less or equal .08	.070

The value of CMIN/DF for the current model was 2.450 which is less than 3 and the value of GFI for the current model is 0.82 which is greater than 0.80. The value of CFI and IFI are also fulfilling the threshold range and the RMSEA is less than 0.08. In

short, all indicators of model fitness are confirming that the current model consisting of four variables named as OA, UIOT, DDIPCs and SCP is fit. Figure 1 reveals the CFA of the current data.

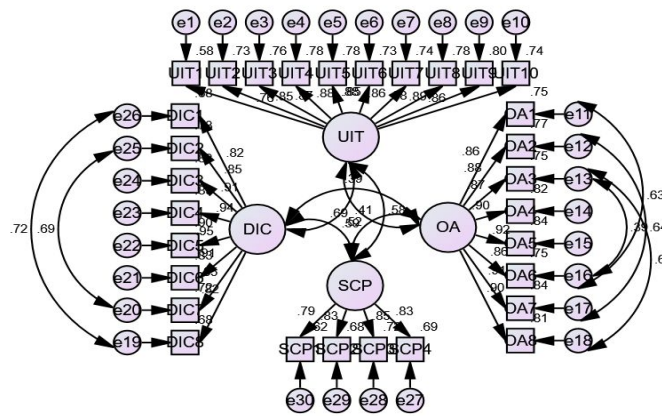

Figure 1. CFA

4.5. Structural Equation Modelling

The hypotheses were tested by running SEM in AMOS where the following results were found

revealing the direct, indirect and total effects of UIOT and DDIPCs on SCP along with the mediating impact of OA.

Table 5. SEM

Total effect	DDIPCs	UIoT	OA
OA	.346***	.452***	.000
SCP	.507***	.285***	.259***
Direct effect	DDIPCs	UIoT	OA
OA	.346***	.452***	.000
SCP	.417***	.168**	.259***
Indirect effect	DDIPCs	UIoT	OA
OA	.000	.000	.000
SCP	.090*	.117**	.000

Note: * indicates p-value<0.1, ** indicates p-value<0.05 and *** indicates p-value<0.01.

The findings of SEM are indicating that DDIPCs has significant and positive total impact on SCP (p-value<0.01) because one unit increase in DDIPCs causes 50.7 percent increase in SCP. Similarly, the UIoT also has significant positive total impact on SCP (p-value<0.01). However, the total impacts on DDIPCs and UIoT on SCP are not equal to their respective direct impacts. The inequality of total and direct effects is indicating the presence of some sort

of mediation in these relationships due to which the indirect impact is caused in dependent variable. This mediation is caused by OA which is a significant positive mediator between DDIPCs and SCP. Similarly, an indirect impact is caused by UIoT on SCP through OA. Hence, the OA is a significant mediator in both relationships. Figure 2 provides the screenshot of SEM taken from AMOS during hypotheses testing.

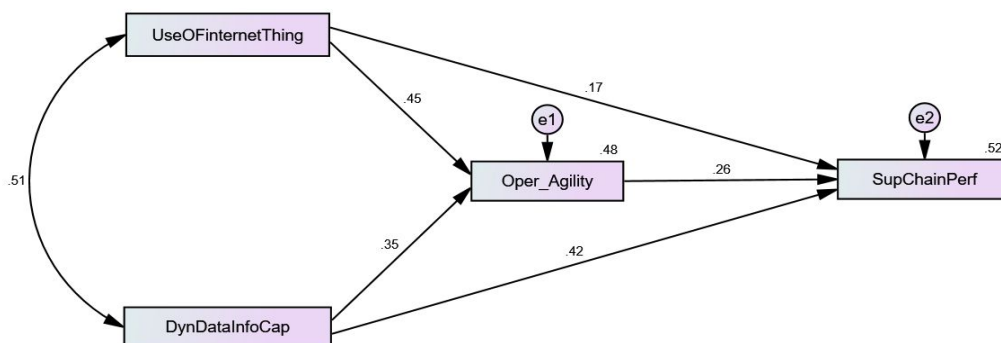

Figure 2. SEM

5. Discussion and Conclusion

5.1. Discussion

This study aimed to see the impact of use of the internet of things (UIoTs) on supply chain performance (SCP) and the impact of dynamic data and information processing capabilities (DDIPCs) on SCP. This study also aimed to know about the

mediating role of operational agility (OA) between UIoTs and SCP and the mediating role of operational agility (OA) between DDIPCs and SCP. The first hypothesis proposed in the study was that, "UIoTs has a significant impact on SCP". This hypothesis is accepted as [27] proposed in the research work for good supply chain management that UIoTs helps in

integrating the different factors like logistics, transport, machinery, devices, gauges and actuators involved in the supply chain, thus improve and integrate the supply SCP and process. The second hypothesis proposed was that, "DDIPCS have a significant impact on SCP", this hypothesis is accepted as per the research work of [28], DDIPCs involve keeping and processing the data of supply chain system and strengthens the OA and SCP. The third hypothesis was that, "OA significantly mediates between UIoTs and SCP", according to [29] OA orients a business towards the directions that are healthy for its growth and betterment of the business operations, so applied OA can increase the impact of UIoTs very effectively to improve the SCP. The fourth hypothesis proposed was that, "OA significantly mediates between DDIPCs and SCP", this hypothesis is accepted according to the research work of Shlomo Tarba, in the article of Technological Forecasting and Social Change, it was accepted that OA acts as a base to improve the business processes so when applied through the DDIPCs it will cause a significant and positive impact on SCP.

5.2. Conclusion

This study aimed to see the impact of UIoTs on SCP and the impact of DDIPCs on SCP. This study also aimed to know about the mediating role of OA between UIoTs and SCP and the mediating role of OA between DDIPCs and SCP. Study was conducted by using questionnaire method in the manufacturing sector of Thailand, the study targeted three hundred people from the manufacturing sector of Thailand and results of the analysis showed that UIoTs and DDIPCs significantly impact SCP and that OA significantly mediates between UIoTs, DDIPCs and SCP.

5.3. Implications of the study

This study has contributed significantly to the literature of the relationship between UIoTs, DDIPCs and SCP and has also highlighted the importance of OA between this relationship and how OA contributes to SCP. UIoTs and DDIPCs can be applied to the manufacturing sector of Thailand or any country globally in order to improve the SCP via OA. Application of UIoTs and DDIPCs should be added in the policies for a successful SC system, this study has its implications globally because in the

manufacturing sector of any country, the SC system is the main element that needs to be improved through OA and by implementing UIoTs and DDIPCs.

5.4. Limitations and future research indications

The problem is globally so the study can be conducted globally as well, targeting the manufacturing sector of any country. A bigger sample can be selected from the manufacturing sector in future researches to get appropriate data and feedback. The method used in the current research is questionnaire method, whereas, in the manufacturing sector, interview can be a more accurate tool, one to one interview can be conducted for the purpose of accurate and authentic data collection. Future researchers can take supplier integration, internal integration or customer integration as a mediator in their researches instead of OA and conduct the same research, using the same dependent and independent variables.

References:

- [1]. A. Gunasekaran, T. Papadopoulos, R. Dubey, S. F. Wamba, S. J. Childe, B. Hazen, and S. Akter, "Big data and predictive analytics for supply chain and organizational performance," *Journal of Business Research*, vol. 70, pp. 308-317, 2017.
- [2]. D. Prajogo, A. Oke, and J. Olhager, "Supply chain processes: Linking supply logistics integration, supply performance, lean processes and competitive performance," *International Journal of Operations & Production Management*, vol. 36, pp. 220-238, 2016.
- [3]. A. AlHogail and M. AlShahrani, "Building consumer trust to improve Internet of Things (IoT) technology adoption," in *International Conference on Applied Human Factors and Ergonomics*, 2018, pp. 325-334.
- [4]. F. Shrouf and G. Miragliotta, "Energy management based on Internet of Things: practices and framework for adoption in production management," *Journal of Cleaner Production*, vol. 100, pp. 235-246, 2015.

- [5]. C.-W. Hsu and C.-C. Yeh, "Understanding the factors affecting the adoption of the Internet of Things," *Technology Analysis & Strategic Management*, vol. 29, pp. 1089-1102, 2017.
- [6]. M. Tarafdar and S. Qrunfleh, "Agile supply chain strategy and supply chain performance: complementary roles of supply chain practices and information systems capability for agility," *International Journal of Production Research*, vol. 55, pp. 925-938, 2017.
- [7]. J. Dawes, *Developing agility and quickness*: Human Kinetics Publishers, 2019.
- [8]. O.-K. Lee, V. Sambamurthy, K. H. Lim, and K. K. Wei, "How does IT ambidexterity impact organizational agility?," *Information Systems Research*, vol. 26, pp. 398-417, 2015.
- [9]. C. A. Lengnick-Hall and T. E. Beck, "Resilience capacity and strategic agility: Prerequisites for thriving in a dynamic environment," in *Resilience Engineering Perspectives*, Volume 2, ed: CRC Press, 2016, pp. 61-92.
- [10]. I. Lee and K. Lee, "The Internet of Things (IoT): Applications, investments, and challenges for enterprises," *Business Horizons*, vol. 58, pp. 431-440, 2015.
- [11]. S. Luthra, D. Garg, S. K. Mangla, and Y. P. S. Berwal, "Analyzing challenges to Internet of Things (IoT) adoption and diffusion: An Indian context," *Procedia Computer Science*, vol. 125, pp. 733-739, 2018.
- [12]. Ghosh, A. K. (2018). Sphene and Zircon Fission Track Analysis of Syenite Rocks of the Sushina Hills, Purulia-Bankura Shear Zone (TPSZ). *International Journal of Geography and Geology*, 7(4), 73-79.
- [13]. P. Akhtar, Z. Khan, S. Tarba, and U. Jayawickrama, "The Internet of Things, dynamic data and information processing capabilities, and operational agility," *Technological Forecasting and Social Change*, vol. 136, pp. 307-316, 2018.
- [14]. M. Tu, "An exploratory study of Internet of Things (IoT) adoption intention in logistics and supply chain management: A mixed research approach," *The International Journal of Logistics Management*, vol. 29, pp. 131-151, 2018.
- [15]. A. A. Atayero, S. Oluwatobi, and P. Alege, "An assessment of the Internet of Things (IoT) adoption readiness of Sub-Saharan Africa," *Journal Of South African Business Research*, vol. 13, 2016.
- [16]. D. Bilgeri and F. Wortmann, "Barriers to IoT business model innovation," 2017.
- [17]. A. Al-Fuqaha, M. Guizani, M. Mohammadi, M. Aledhari, and M. Ayyash, "Internet of things: A survey on enabling technologies, protocols, and applications," *IEEE communications surveys & tutorials*, vol. 17, pp. 2347-2376, 2015.
- [18]. S. Li, L. Da Xu, and S. Zhao, "The internet of things: a survey," *Information Systems Frontiers*, vol. 17, pp. 243-259, 2015.
- [19]. C. Choi, T. C. Greenwell, M. A. Hums, and M. E. Hambrick, "Understanding Consumer Behaviors in Virtual Golf: Differences in Leisure Constraints," *Sport Marketing Quarterly*, vol. 28, 2019.
- [20]. Z. Zhang, D. Chen, Y. Feng, Z. Yuan, B. Chen, W. Qin, S. Zou, S. Qin, and J. Han, "A strategy for enhancing the operational agility of petroleum refinery plant using case based fuzzy reasoning method," *Computers & Chemical Engineering*, vol. 111, pp. 27-36, 2018.
- [21]. E. M. Goldratt, *Necessary but not sufficient: a theory of constraints business novel*: Routledge, 2017.
- [22]. F. T. C. Tan, B. Tan, W. Wang, and D. Sedera, "IT-enabled operational agility: An interdependencies perspective," *Information & Management*, vol. 54, pp. 292-303, 2017.
- [23]. Ismail, N. H., Mohamad, N., & Rawian, R. M. (2018). A New Revolution of Indie Literary Work. *International Journal of Asian Social Science*, 8(9), 706-711.
- [24]. Margaret, A.C. and G. Donna. Educational media: Potential impacts on tertiary students' mental health. *International Journal of Innovation, Creativity and Change*, 3(3): 61-88, 2017.
- [25]. R. Gove and K. E. Salsman, "Imaging system with foveated imaging capabilities," ed: Google Patents, 2015.
- [26]. H. Shin, J.-N. Lee, D. Kim, and H. Rhim, "Strategic agility of Korean small and medium enterprises and its influence on operational and firm performance," *International Journal of*

- Production Economics, vol. 168, pp. 181-196, 2015.
- [27]. A. Gilchrist, *Industry 4.0: the industrial internet of things*: Apress, 2016.
- [28]. S. Sicari, A. Rizzardi, L. A. Grieco, and A. Coen-Porisini, "Security, privacy and trust in Internet of Things: The road ahead," *Computer networks*, vol. 76, pp. 146-164, 2015.
- [29]. K. Suankaewmancee, D. T. Hoang, D. Niyato, S. Sawadsitang, P. Wang, and Z. Han, "Performance analysis and application of mobile blockchain," in *2018 international conference on computing, networking and communications (ICNC)*, 2018, pp. 642-646.
- [30]. Jermstittiparsert, K., Sutduean, J., & Sutduean, C. (2019). Sustainable Procurement & Sustainable Distribution Influence the Organizational Performance (Economic, Social and Environmental): Moderating Role of Governance and Collaboration at Thai Food Industry. *International Journal of Supply Chain Management*, 8(3), 83-94.
- [31]. Sutduean, J., Prianto, A., & Jermstittiparsert, K. (2019). The Moderating Role of Marketing Communications in the Relationship between Supply Chain Integrations and Supply Chain Performance. *International Journal of Innovation, Creativity and Change*, 5(2), 193-210.
- [32]. Jermstittiparsert, K. & Pithuk, L. (2019). Exploring the Link between Adaptability, Information Technology, Agility, Mutual Trust, and Flexibility of a Humanitarian Supply Chain. *International Journal of Innovation, Creativity and Change*, 5(2), 432-447.
- [33]. Chienwattanasook, K. & Jermstittiparsert, K. (2018). Supply Chain Integration, Supply Chain Risk Practices and Supply Chain Performance: A Contingent View. *Opcion* 34(86), 2160-2177.
- [34]. Maria, I.M.-B. and A.P.V. María, 2017. Respondent conditioning training effect on the behavior of the audience of creativity. *International Journal of Innovation, Creativity and Change*, 3(2): 18-32, 2017.
- [35]. Waqas, H. and S. Bahrain, Risk Management, Capital Adequacy and Audit Quality for Financial Stability: Assessment from Commercial Banks of Pakistan. *Asian Economic and Financial Review*, 2019. 9(6): p. 654-664.