



Mongolian Academy of Sciences

Mongolian Journal of Chemistry

The Institute of Chemistry & Chemical Technology

Source identification of N₂O produced during simulated wastewater treatment under different oxygen conditions using stable isotopic analysisT.Azzaya^{1*}, Sakae Toyoda², NaohiroYoshida^{3,4}, Hiroshi Shiomi⁵, Rina Kouno^{5#}¹*Institute of Chemistry and Chemical Technology, MAS, Peace ave., Ulaanbaatar, 13330, Mongolia*²*Department of Environmental Science and Technology, Tokyo Institute of Technology, 4259 Nagatsuta, Midori-ku, Yokohama, 226-8502, Japan*³*Department of Environmental Chemistry and Engineering, Tokyo Institute of Technology, 4259 Nagatsuta, Midori-ku, Yokohama, 226-8502, Japan*⁴*Earth-Life Science Institute, Tokyo Institute of Technology, Meguro-ku, Tokyo, 152-8551, Japan*⁵*Bureau of Sewerage, #Bureau of Waterworks, Tokyo Metropolitan Government, 2-8-1 Nishi-shinjyuku, Shinjyuku-ku, Tokyo 163-8001, Japan*

ARTICLE INFO: Received 15 November 2014; revised 18 November 2014; accepted 22 November 2014

Abstract: Nitrous oxide (N₂O), a potent greenhouse gas which is important in climate change, is predicted to be the most dominant ozone depleting substance. It is mainly produced by oxidation of hydroxylamine (NH₂OH) or reduction of nitrite (NO₂⁻) during microbiological processes such as nitrification and denitrification. Wastewater treatment plant (WWTP) is one of the anthropogenic N₂O sources because inorganic and organic nitrogen compounds are converted to nitrate (NO₃⁻, in the case of standard system) or N₂ (in the case of advanced system) by bacterial nitrification and denitrification in WWTP. We investigated the N₂O production mechanisms during batch experiments that simulate wastewater treatment with activated sludge under various dissolved oxygen (DO) concentrations by stable isotope analysis. About 125 mL of water was sampled from 30L incubation chamber for several times during the incubation, and concentration and isotopomer ratios of N₂O and N-containing species were measured using gas chromatography/isotope ratio mass spectrometry (GC/IRMS). Ammonium (NH₄⁺) consumption was accompanied by increment of nitrite (NO₂⁻), and at the same time dissolved N₂O concentration gradually increased to 4850 and 5650 nmol kg⁻¹, respectively, during the four-hour incubation when DO concentrations were 0.2 and 0.5 mg L⁻¹. Observed low SP values (0.2-8.9% at DO-0.2 mg L⁻¹, -5.3-6.3% at DO-0.5 mg L⁻¹, -1.0-8.3% at DO-0.8 mg L⁻¹) in N₂O and relationship of nitrogen isotope ratios between N₂O and its potential substrates (NH₄⁺, NO₃⁻) suggested that N₂O produced under the aerobic condition derived mainly from NO₂⁻ reduction by ammonia-oxidizing bacteria (nitrifier-denitrification).

Keywords: N₂O; Isotopomer ratios; Wastewater; N₂O production; Aerobic condition**INTRODUCTION**

N₂O is a significant greenhouse gas, with an approximately 300-fold stronger effect than carbon dioxide [1]. N₂O also contributes to the destruction of the stratospheric ozone layer [2]. N₂O emission resulting from microbial activity has been detected in many man-made and natural environments, such as wastewater treatment facilities, plants, soils, and sediments. A major danger is that the proportion of N₂O emission from wastewater treatment will increase continuously [3, 4]. N₂O emission can result from the activity of different groups of microorganisms in used wastewater treatment: ammonia oxidizing bacteria (AOB, [5]), nitrite oxidizing bacteria (NOB, [6]), and denitrifying microorganisms [7]. The major microbial N₂O production pathways are nitrification, denitrification,

and nitrifier-denitrification [8-10]. N₂O is produced as a byproduct of hydroxylamine (NH₂OH) oxidation (Eq. (1)), an intermediate during nitrate (NO₃⁻) reduction to dinitrogen (N₂) (Eq. (2)), and as the end product of nitrifier-denitrification (Eq. (3)).

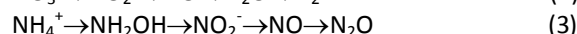
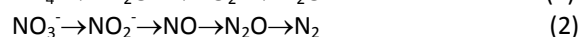
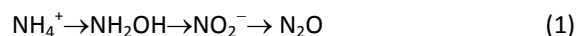

Given the high global warming potential, N₂O emissions are a critical component of greenhouse gas emissions reduction targets. However, contributions of individual sources to regional N₂O budgets are difficult to estimate because of large spatial and temporal variability in fluxes [11]. Therefore, it is necessary to evaluate the relative importance of

* corresponding author: e-mail: azzaya.usb@gmail.comDOI: <http://doi.dx.org/10.5564/mjc.v15i0.313>

microbial pathways for N_2O production and consumption mechanism based on the use of adequate application which is required to estimate qualitative and quantitative information in N_2O global budget. Stable isotope ratios of nitrogen and oxygen are acknowledged recently as useful tools for analyzing processes contributing to N_2O production and for detecting gross N_2O consumption [12]. With knowledge of isotopic signatures of precursor materials (ammonium, NH_4^+ ; nitrate, NO_3^-), and effects of O-atom exchange between water and intermediates of nitrification or denitrification processes on the oxygen isotope ratio in N_2O [13], the isotopomer ratios of N_2O ($\delta^{15}N^{bulk}$ and $\delta^{18}O$, see Eqs. (4) and (5) in Experimental section) are useful to ascertain the N_2O formation and decomposition processes. Aside from the bulk isotope ratios (average isotope ratios for $^{14}N/^{15}N$ and $^{18}O/^{16}O$), the ^{15}N site preference (SP value, indicating the difference of

dynamic conditions or a low ratio of carbon to N-compounds during heterotrophic denitrification [26]. However, more studies associated with isotopic analysis are needed to understand the relative contributions from each N_2O production pathway in wastewater treatment operated under different conditions, especially dissolved DO. It would have been essential to formulate operating strategies that minimize N_2O emissions.

The aim of this study was to elucidate the production mechanisms of N_2O in the wastewater treatment under various reduced DO conditions. In this frame, a laboratory batch-scale experiments associated with nitrification process was performed to measure the stable isotopic signatures under key controlling factor of DO. The N_2O production pathways were identified based on enrichment factors for each microbial process and isotopic information of substrate (NH_4^+ and NO_3^-) and product (N_2O).

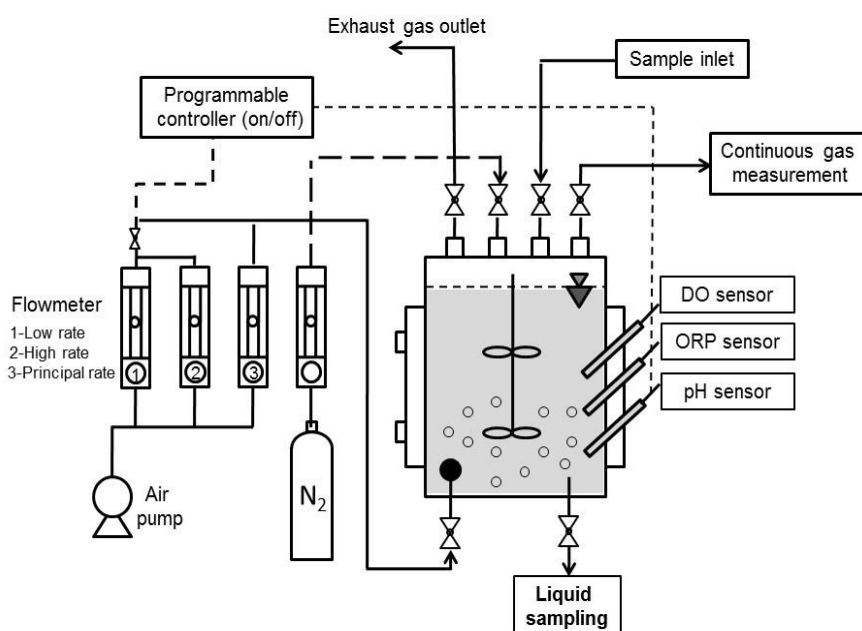

Fig 1. Schematic of the laboratory-scale incubation apparatus.

$^{15}N/^{14}N$ ratio between central (α) and terminal (β) nitrogen position in the linear N_2O molecule, i.e. $\beta N^\alpha NO$) was first found to vary significantly throughout the atmosphere by Yoshida and Toyoda [14]. SP, which is independent of the substrate's isotopic signature, has unique values reflecting microbial production pathways. SPs of N_2O produced by NH_2OH oxidation and by NO_2^- reduction were respectively about 33% and 0% [15-18] that can be a robust parameter in the analysis of mechanisms.

In the last years, several efforts have been made to better understand the mechanisms of N_2O production based on the isotopomer ratios of N_2O in complex bacterial system during wastewater treatment [19-23]. Moreover, several parameters favoring N_2O production were identified: low dissolved oxygen (DO) concentration, accumulation of nitrite [24, 25],

EXPERIMENTAL

Lab-scale experimental apparatus: A laboratory-scale incubation apparatus with a working volume of 30 L capacity (Fig. 1) is filled with activated sludge. Gas phase in the incubation vessel (about 7 L) was purged continuously with N_2 gas flow of about $4 L min^{-1}$ by a flow controller. The air was applied from the vessel bottom using three flow controllers to adjust the oxygen concentrations in aerobic (nitrification) experiments. Dissolved oxygen (DO), pH, and oxidation-reduction potential (ORP) were measured using oxygen, pH, and ORP electrodes (DO-31P, HM-31P; TOA-DDK), respectively. The pH was held constant at around 7.

Batch incubation experiment: Batch experiments were conducted during February-March in 2012 with activated sludge taken from the biological oxic tank at

a municipal WWTP located in eastern Tokyo. A 30 L of activated sludge was put into the incubation apparatus. The operating parameters (air flow, temperature and pH) were optimized to keep DO at designated level before starting the experiment. Experiments were conducted at different oxygen concentrations ranged in 0.2 to 0.8 mg L⁻¹. The water temperature was set at 18°C. The experiments were started by adding the NH₄Cl solution with 6 g-N L⁻¹ concentration as a substrate. The pH was adjusted by NaHCO₃. For concentration analyses of dissolved inorganic nitrogen (DIN) species and isotopic analyses of N₂O, water was sampled from the incubation apparatus at 15 min intervals until 1 h, and then at 60 min intervals until 240 min. Samples for N₂O analysis were stored in 125 ml glass vials (Maruemu Corp. Co. Ltd., Osaka, Japan) after adding 5 ml of saturated HgCl₂, which stops microbial activity and which prevents the release of N₂O by microbes in the sample and sealed with butyl rubber stoppers and aluminum caps.

Analysis: The concentration of dissolved NH₄⁺ was measured using a coulometric ammonia meter (MT-1; Central Kagaku Corp., Tokyo, Japan, and MM-60R; DKK-TOA Corp., Tokyo, Japan). Those of NO₃⁻ and NO₂⁻ were measured using an ion chromatograph equipped with a conductivity detector (DX-320; Dionex Corp., Osaka, Japan). The term *isotopomer* first used by Toyoda and Yoshida [27], is defined as a set of molecules that are isotopically substituted, usually

with stable isotopes. However, different nomenclatures exist for molecules that have the same constitution and configuration, as summarized by Toyoda et al. [28]. A new term is necessary to avoid confusion. For the present study, the N₂O isotopomer ratios (bulk nitrogen and oxygen isotope ratios, δ¹⁵N^{bulk} and δ¹⁸O, and intramolecular ¹⁵N site preference, SP) were measured using an online system containing preconcentration traps, chemical traps for removing H₂O and CO₂, and a gas chromatograph-isotope ratio mass spectrometer (GC-IRMS; MAT 252, Thermo Fisher Scientific K.K., Yokohama, Japan). A complete description of this approach and the procedures used for calibration of standard N₂O for isotopomer ratios were described by Toyoda and Yoshida [27]. Isotopomer ratios are noted as d values, defined according to Eqs. (4) and (5):

$$\delta^{15}\text{N}^i = {}^{15}\text{R}_{\text{sample}}^i / {}^{15}\text{R}_{\text{standard}} - 1 \quad (i = \alpha, \beta, \text{ or bulk}) \quad (4)$$

$$\delta^{18}\text{O} = {}^{18}\text{R}_{\text{sample}} / {}^{18}\text{R}_{\text{standard}} - 1 \quad (5)$$

In those equations, ¹⁵R^α and ¹⁵R^β respectively represent the ¹⁵N/¹⁴N ratios at central (α) and terminal (β) nitrogen position in the linear N₂O molecule, i.e. ^βN^αNO. ¹⁵R^{bulk} and ¹⁸R respectively denote the average values of ¹⁵N/¹⁴N and ¹⁸O/¹⁶O ratios. The subscript "standard" signifies an international standard: atmospheric N₂ for N, and Vienna Standard Mean Ocean Water (V-SMOW) for O.

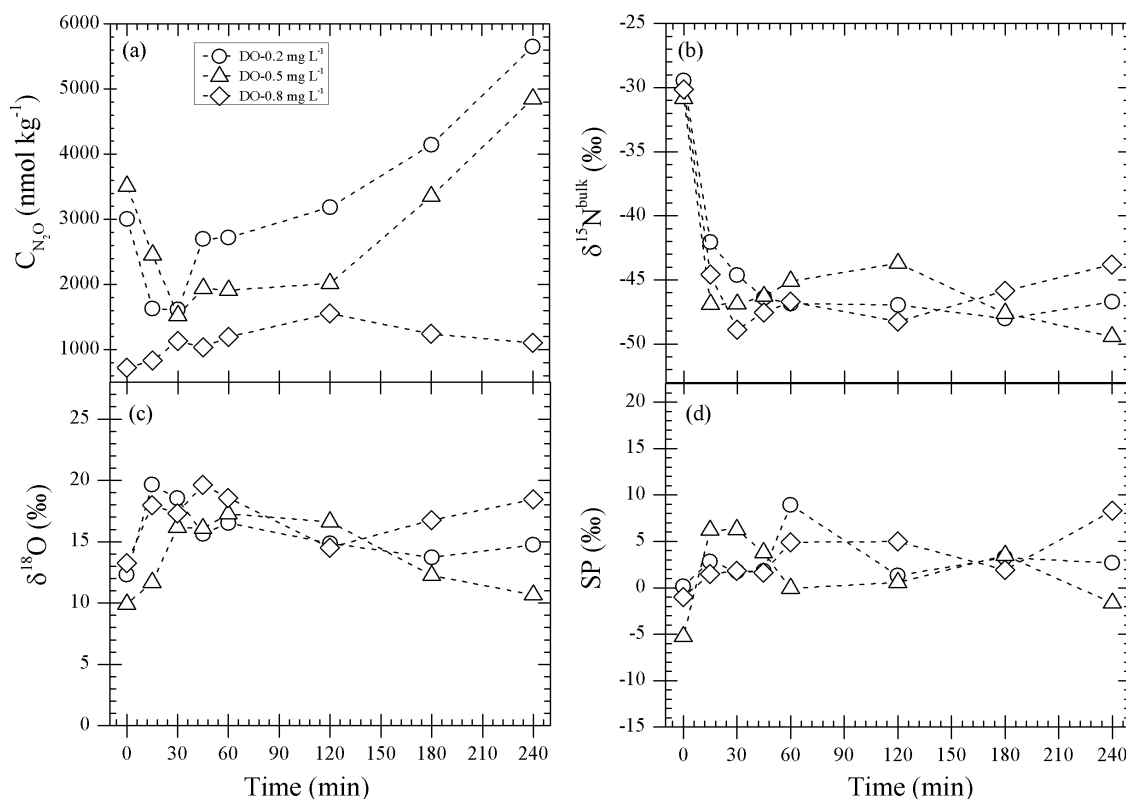

Fig. 2. Time course of concentration of N₂O (a) and its isotopomer ratios (δ¹⁵N^{bulk}, SP, δ¹⁸O) (b-d) under aerobic condition with different DO settings

In addition, the ^{15}N site preference was calculated from isotopomer ratios [27] as shown below.

In those equations, $^{15}\text{R}^{\alpha}$ and $^{15}\text{R}^{\beta}$ respectively represent the $^{15}\text{N}/^{14}\text{N}$ ratios at central (α) and terminal (β) nitrogen position in the linear N_2O molecule, i.e. $^{\beta}\text{N}^{\alpha}\text{NO}$. $^{15}\text{R}^{\text{bulk}}$ and ^{18}R respectively denote the average values of $^{15}\text{N}/^{14}\text{N}$ and $^{18}\text{O}/^{16}\text{O}$ ratios. The subscript *standard* signifies an international standard: atmospheric N_2 for N, and Vienna Standard Mean Ocean Water (V-SMOW) for O. In addition, the ^{15}N site preference was calculated from isotopomer ratios [27] as shown below.

$$^{15}\text{N site preference (SP)} = \delta^{15}\text{N}^{\alpha} - \epsilon^{15}\text{N}^{\beta} \quad (6)$$

Therein, the δ values and SP value are expressed in permil (‰). Measurement precision was typically better than 1‰ for concentration, 0.1‰ for $\delta^{15}\text{N}^{\text{bulk}}$, 0.5‰ for $\delta^{18}\text{O}$, and better than 0.4‰ for $\delta^{15}\text{N}^{\alpha}$ and $\delta^{15}\text{N}^{\beta}$.

The $\delta^{15}\text{N}$ and $\delta^{18}\text{O}$ of NO_3^- were measured using the denitrifier method [29, 30], where N_2O produced by *Pseudomonas aureofaciens* (NBRC 3521) from NO_3^- was analyzed as described above.

RESULTS AND DISCUSSION

Dissolved N_2O and inorganic nitrogen concentrations; The distributions of N_2O and inorganic nitrogen species (NH_4^+ , NO_2^- and NO_3^-) in the water during aerobic incubation under three DO conditions (0.2, 0.5, and 0.8 mg L^{-1}) are presented in Figure 2(a) and 3(a-c). In all three experiments, dissolved N_2O concentration was always greater than the concentration expected under water-atmospheric equilibrium (approximately 9 nmol kg^{-1} at 20°C [31], indicating that N_2O production occurred at the range of oxygen concentrations tested in this study (Fig. 2a). N_2O production started as soon as NH_4^+ was added and decreased rapidly between 15 and 30 min. It then increased to 4849.2-5649.2 nmol kg^{-1} at the end of time courses with lower DO conditions of 0.2 or 0.5 mg L^{-1} , respectively. The magnitude of the increase in N_2O from 60 min to 240 min was the highest in the experiment with a DO setting of 0.2 mg L^{-1} , about three times greater than the increase observed in the experiment with a DO setting of 0.8 mg L^{-1} . These results agree with those of previous studies, which also found that lower DO concentrations engender higher N_2O emissions during nitrification [25, 32]. At DO setting of 0.8 mg L^{-1} , the N_2O concentration was ranged around 1000 nmol kg^{-1} throughout the time courses after 30 min of the incubation, indicating N_2O is produced with slightly lower amount than those of at limited DO conditions, which is consistent with findings by Zheng *et al.* [33] who reported that the higher DO level can minimize N_2O production.

The NH_4^+ concentrations in all experiments reduced gradually while the NO_2^- and NO_3^- were increasing until the end of incubation, which confirms the

presence of AOB and NOB, and indicates that no significant heterotrophic activity contributing to N_2O production in this condition. Under low oxygen condition (0.2 mg L^{-1}), NH_4^+ was oxidized approximately 78.1% with high oxidation rate (4.7 $\text{mmol L}^{-1} \text{min}^{-1}$) at 240 min while it was about 28.7% with low oxidation rate (1.8 $\text{mmol L}^{-1} \text{min}^{-1}$) at higher DO of 0.8 mg L^{-1} (Fig. 3a).

The NO_3^- and NO_2^- concentrations were increased throughout the incubation period (Fig. 3b-c). Especially, NO_2^- concentration reached to 189.8 mmol L^{-1} at DO of 0.2 mg L^{-1} , which also agrees with the results of previous studies [4, 32] showing that high

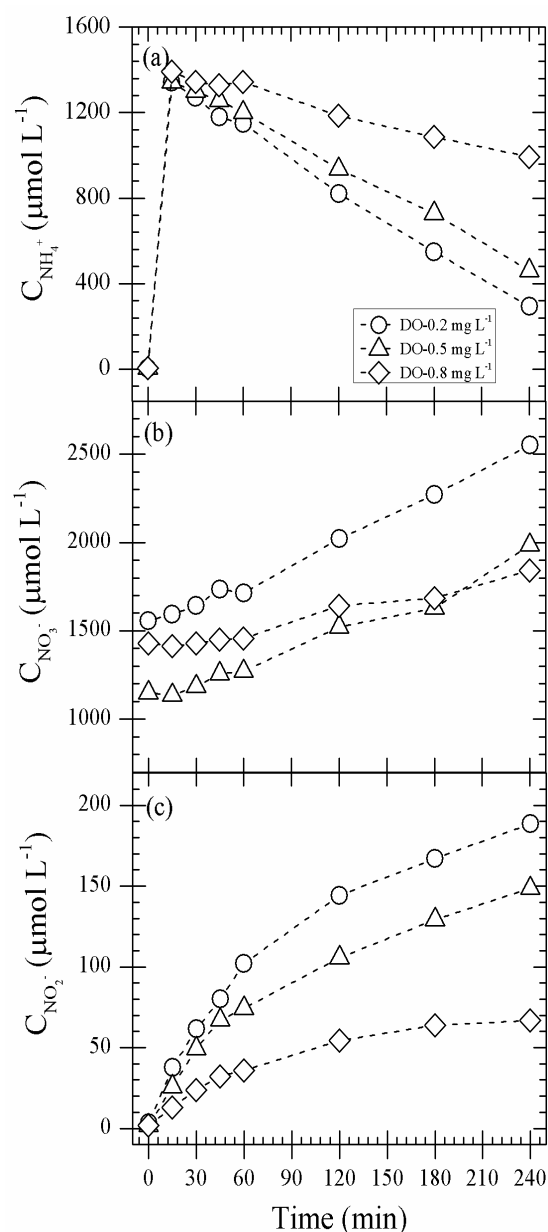

Fig 3. Distribution of inorganic nitrogen species (a: NH_4^+ , b: NO_2^- , c: NO_3^-) during the three experiments with different DO settings (0.2, 0.5 and 0.8 mg L^{-1})

NO_2^- accumulation can also be key parameter regarding high N_2O production. In an insufficient oxygen condition, autotrophic NH_4^+ oxidizers use NO_2^- as the terminal electron acceptor, nitrifier denitrification by AOB and some strains of *Nitrosospira spp.*, which are expected to be more abundant in activated sludge, are responsible for the high N_2O production [26] during nitrification. The interpretations based on concentration measurements are examined further using the stable isotope analysis described below.

Source-partitioning of N_2O deduced from isotopic analysis:

Isotopic analysis is useful tool for differentiating the source of N_2O production processes such as NH_2OH oxidation and bacterial NO_2^- reduction in several environments [18, 34, 35]. We discuss the N_2O production processes under steady state assuming that production processes were unchanged at $t=15$ min or later. This assumption is based on the time series measurements. Therefore, we can regard the isotopomer ratios after 15 min as values for N_2O produced in this system, because isotope fractionation associated with emission of dissolved N_2O to the gas phase is small enough compared to that related to N_2O production [36]. In this study, isotope ratios of N_2O ($\delta^{15}\text{N}$, $\delta^{18}\text{O}$, and SP values) showed variations during the incubation and variations among the experiments with different DO concentrations (Figs. 2(b)–2(d)). In general, the $\delta^{15}\text{N}$ value of N_2O decreased rapidly from the beginning of incubation (-29.4–30.1‰) to $t=15$ min (-42.1–46.9‰) at all DO settings. Thereafter, it was becoming nearly constant ranged in -44.9–49.5‰ between 30 and 240 min. Not so much difference in $\delta^{15}\text{N}$ was occurred between experiments (Fig. 2b). The $\delta^{18}\text{O}$ value of N_2O showed a general decrease from 16.3–18.5‰ at 30 min to 10.7–14.5‰ at 240 min after great increase at 15 min when DO were 0.2 and 0.5 mg L^{-1} , respectively (Fig. 2c). Basically, N_2O reduction (consumption) is accompanied by a simultaneous increase in the $\delta^{15}\text{N}$ and $\delta^{18}\text{O}$ values and a diffusive loss of N_2O from the water to the atmosphere occurs with a marginal isotope effect. Therefore, the observed decrease in the $\delta^{15}\text{N}$ and $\delta^{18}\text{O}$ values of N_2O is interpreted as an isotope effect in microbial N_2O production during the incubation. The SP value of N_2O showed almost constant profile ranging in 0.2–8.3‰ at all experiments (Fig. 2d). The SP is independent of the isotopic signature of the substrate and has unique values that reflect microbial production pathways [15, 16, 18]. Therefore, we analyzed the N_2O production processes using SP– $\delta^{15}\text{N}^{\text{bulk}}$ diagram. In Figure 4, the data obtained at $t = 15$ min or later are plotted in SP– $\delta^{15}\text{N}^{\text{bulk}}$ diagram. It is suggested that N_2O should have been produced by NH_2OH oxidation (nitrification) or NO_2^- reduction (nitrifier-denitrification) pathways, since this experiment was conducted under oxic conditions. It is reported that the ranges of SP of N_2O produced by the two pathways were defined as 33 ±

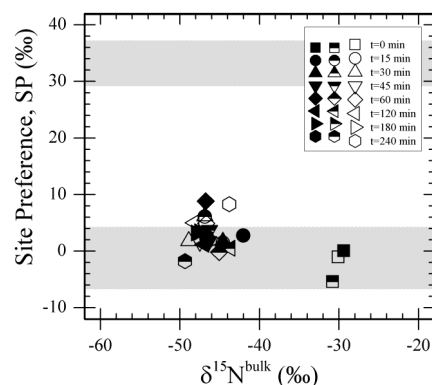

Fig. 4. Relationships between SP and $\delta^{15}\text{N}^{\text{bulk}}$ values of dissolved N_2O at DO settings of 0.2 mg L^{-1} (closed symbols), 0.5 mg L^{-1} (half closed symbols) and 0.8 mg L^{-1} (open symbols). Expected ranges of $\delta^{15}\text{N}^{\text{bulk}}$ values for the N_2O produced by NH_2OH oxidation and NO_2^- reduction estimated using Eqn. (7) and those of SP are shown by gray boxes at the top and bottom sides.

4‰ for NH_2OH oxidation and -1.0 ± 5.5 ‰ for NO_2^- reduction according to estimations based on literature values [12]. The range is shown by the vertical side of the gray boxes in Figure 4. On the other hand, $\delta^{15}\text{N}$ of N_2O produced by each process can be estimated from $\delta^{15}\text{N}$ of substrate (NH_4^+ or NO_2^-) and isotopic enrichment factor for the pathway using the following equation.

$$\delta^{15}\text{N}_{\text{N}_2\text{O}} = \delta^{15}\text{N}_{\text{substrate}} + \epsilon(^{15}\text{N})_{\text{substrate} \rightarrow \text{N}_2\text{O}} \quad (7)$$

The $\delta^{15}\text{N}$ – NH_4^+ is estimated from NH_4^+ concentration data using Rayleigh isotope fractionation model [37], Eqn. 8, assuming that initial $\delta^{15}\text{N}$ – NH_4^+ and $e(^{15}\text{N})$ for NH_4^+ consumption were common to all experiment.

$$\delta X = \delta_0 X + e(X) \ln(C/C_0) \quad (8)$$

The range of $e(^{15}\text{N})_{\text{NH}_4^+ \rightarrow \text{N}_2\text{O}}$ obtained by studies incubating pure culture of nitrifying bacteria under aerobic conditions (-60 to -48‰, [19]) is assumed to represent ^{15}N -enrichment factor for N_2O production from NH_4^+ via NH_2OH . Resulting range of $\delta^{15}\text{N}^{\text{bulk}}$ for N_2O produced by NH_2OH oxidation in all experiment is shown by the upper gray rectangle in Fig. 4. Because $\delta^{15}\text{N}$ – NO_2^- was not measured individually in this study, we estimate $\delta^{15}\text{N}^{\text{bulk}}$ for N_2O produced by NH_4^+ oxidation to NO_2^- followed by NO_2^- reduction using $\delta^{15}\text{N}$ – NH_4^+ and $e(^{15}\text{N})_{\text{NH}_4^+ \rightarrow \text{NO}_2^- \rightarrow \text{N}_2\text{O}}$. The $e(^{15}\text{N})_{\text{NH}_4^+ \rightarrow \text{NO}_2^- \rightarrow \text{N}_2\text{O}}$ is estimated from $e(^{15}\text{N})_{\text{NH}_4^+ \rightarrow \text{NO}_2^-}$ and $e(^{15}\text{N})_{\text{NO}_2^- \rightarrow \text{N}_2\text{O}}$ reported in literature (-76 to -11‰, [19]). Calculated range of $\delta^{15}\text{N}^{\text{bulk}}$ for N_2O produced by NO_2^- reduction in all experiment is shown by the bottom gray rectangle. As shown in Figure 4, all data points were within the range of reported values for N_2O produced from NH_4^+ via NO_2^- reduction (-14–5‰, [38]). Together with the fact that NH_4^+ was progressively depleted and NO_2^- was accumulated (Figs. 3a, 3c), this

indicates that the nitrifier–denitrification by AOB was the major N₂O production process with 70-100% of contribution at all DO concentrations which is remarkably consistent with previous results [23].

Finally, we checked the occurrence of the N₂O reduction in this condition by the correlation between $\delta^{15}\text{N}^{\text{bulk}}$ and $\delta^{18}\text{O}$. The slope has negatively correlated (slope = -0.125, R²=0.09 for DO-0.2 mg L⁻¹, slope = -0.158, R²=0.09 for DO-0.5 mg L⁻¹, slope = -0.220, R²=0.377 for DO-0.8 mg L⁻¹) at the time intervals and was extremely lower than those of previously reported data [39]. Consequently, we assumed the contribution of N₂O reduction is small and that the change in isotopomer ratios is negligible during the emission of N₂O from water to gas phase.

CONCLUSION

Results obtained in this study emphasize the usefulness of SP-N₂O together with isotopic signature of NH₄⁺ and NO₃⁻ and isotopic enrichment factor for interpretation of N₂O production mechanisms during simulation of nitrification in a lab-scale biological wastewater treatment. Based on this information, the dependency of the relative contributions on operational parameters and biological conditions that lead to N₂O emission by nitrification in a full scale wastewater treatment system can be controlled and in so doing mitigate emissions of an important greenhouse gas. Batch incubation experiments with activated sludge were conducted under aerobic condition to investigate the critical factors that control N₂O production. The main findings include: The dissolved N₂O concentration was reached up to its maximum around 5649.2nmol/kg at 240 min after substrate addition when DO concentration was set at 0.2 mg L⁻¹. The N₂O production was highly dependent upon DO conditions.

High accumulation of nitrite can be circumstances of N₂O production. Most of ammonia is converted into nitrate or nitrite during the incubation. There was no heterotrophic microbial activity occurred on the basis of the presence of AOB and NOB.

Nitrifier-denitrification by AOB during NH₄⁺ oxidation was the major contributor for N₂O production at all experiments as implied by the isotopomer analysis (SP, $\delta^{15}\text{N}^{\text{bulk}}$, $\delta^{18}\text{O}$). Correlation between $\delta^{15}\text{N}^{\text{bulk}}$ and $\delta^{18}\text{O}$ revealed that no N₂O reduction occurred.

ACKNOWLEDGEMENTS

This work was partly funded by Global Environmental Research Fund (A-0904) of the Ministry of Environment, Japan and JSPS KAKENHI Grant Number 23224013. We thank the technical staff of the Bureau of Sewerage, Tokyo Metropolitan Government for sampling. A. Tumendelger was supported by Global COE program “From the Earth to Earths” project of MEXT.

REFERENCE

1. Intergovernmental Panel on Climate Change (IPCC), Climate Change 2007: Synthesis report. Geneva, Switzerland.
2. Conrad R. (1996) Soil microorganisms as controllers of atmospheric trace gases (H₂, CO, CH₄, OCS, N₂O, and NO). *Microbiol. Rev.*, **60**, 609–640.
3. Garnier J., Cebon A., Tallec G. *et al.* (2006) Nitrogen behaviour and nitrous oxide emission in the tidal Seine River estuary (France) as influenced by human activities in the upstream watershed. *Biogeochemistry*, **77**, 305–326.
4. Itokawa H., Hanaki K., Matsuo T. (2001) Nitrous oxide production in high-loading biological nitrogen removal process under low COD/N ratio condition. *Water Res.*, **35**, 657–664.
5. Lipschultz F., Zafiriou O.C., Wofsy S.C. *et al.* (1981) Production of NO and N₂O by soil nitrifying bacteria. *Nature*, **294**, 641–643.
6. Freitag A., Bock E., (1990) Energy-conservation in Nitrobacter. *FEMS Microbiol. Lett.*, **66**, 157–162.
7. Firestone M.K., Firestone R.B., Tiedje J.M. (1979) Nitric oxide as an intermediate in denitrification: evidence from N-13 isotope exchange. *Biochem. Biophys. Res. Commun.*, **91**, 10–16.
8. Granli T., Bockman O.C., (1994) Nitrous oxide from agriculture. In: Wiig, M. (Ed.), *Norwegian Journal of Agricultural Sciences* (Suppl. 12), 1-128.
9. Bremner J.M. (1997) Sources of nitrous oxide in soils. *Nutr. Cycl. Agroecosyst.*, **49**, 7-16.
10. Barnard R., Leadley P.W., Hungate B.A., (2005) Global change, nitrification, and denitrification: a review. *Global Biogeochem. Cycles*, **19**, GB1007.
11. Turner D.A., Chen D., Galbally I.E. *et al.* (2008) Spatial variability of nitrous oxide emissions from an Australian irrigated dairy pasture. *Plant Soil*, **309**, 77–88.
12. Toyoda S., Yano M., Nishimura S. (2011b) Characterization and production and consumption processes of N₂O emitted from temperate agricultural soils determined via isotopomer ratio analysis. *Global Biogeochem. Cycles*, **25**, GB 2008.
13. Kool D.M., Wrage N., Oenema O., (2007) Oxygen exchange between (de)nitrification intermediates and H₂O and its implications for source determination of NO₃⁻ and N₂O: a review. *Rapid Commun. Mass Spectrom.*, **21**, 3569-3578.
14. Yoshida N., Toyoda S., (2000) Constraining the atmospheric N₂O budget from intramolecular site preference in N₂O isotopomers. *Nature*, **405**, 330-334.
15. Sutka R.L., Ostrom N.E., Ostrom P.H. *et al.* (2003) Nitrogen isotopomer site preference of N₂O produced by *Nitrosomonas europaea* and *Methylococcus capsulatus* Bath. *Rapid. Commun. Mass Spectrom.*, **17**, 738–745.

16. Sutka R.L., Ostrom N.E., Ostrom P.H. et al., (2004) Nitrogen isotopomer site preference of N₂O produced by *Nitrosomonas europaea* and *Methylococcus capsulatus* Bath. *Rapid. Commun. Mass Spectrom.*, **18**, 1411–1412.
17. Sutka R.L., Ostrom N.E., Ostrom P.H. et al., (2006) Distinguishing nitrous oxide production from nitrification and denitrification on the basis of isotopomer abundances. *Appl. Environ. Microbiol.*, **72**, 638–644.
18. Toyoda S., Mutobe H., Yamagishi H. et al., (2005) Fractionation of N₂O isotopomers during production by denitrifier. *Soil Biol. Biochem.*, **37**, 1535–1545.
19. Toyoda S., Suzuki Y., Hattori S. et al., (2011a) Isotopomer analysis of production and consumption mechanisms of N₂O and CH₄ in an advanced wastewater treatment system. *Environ. Sci. Technol.*, **45**, 917.
20. Townsend-Small A., Pataki D.E., Tseng L.Y. et al. (2011) Nitrous oxide emissions from water reclamation plants in southern California. *J. Environ. Qual.*, **40**, 1542–1550.
21. Wunderlin P., Lehmann M.F., Siegrist H. et al. (2013) Isotope signatures of N₂O in a mixed microbial population system: Constraints on N₂O producing pathway in wastewater treatment. *Environ. Sci. Tech.*, **47**, 1339–1348.
22. Tumendelger A., Toyoda S., Yoshida N. (2014a) Isotopic analysis of N₂O produced in a conventional wastewater treatment system operated under different aeration conditions. *Rapid Commun. Mass. Spectrom.*, **28**, 1883-1892.
23. Tumendelger A., Toyoda S., Yoshida N. et al. (2014b) Isotopomeric characterization of N₂O dynamics during simulated wastewater treatment under aerobic and anaerobic conditions. *Geochem. J.* (submitted).
24. Rassamee V., Sattayatewa C., Pagilla K. et al. (2011) Effect of oxic and anoxic conditions on nitrous oxide emissions from nitrification and denitrification processes. *Biotechnology and Bioengineering*, **108**(9), 2036-2045.
25. Tallec G., Garnier J., Billen G. et al. (2006) Nitrous oxide emissions from secondary activated sludge in nitrifying conditions of urban wastewater treatment plants: effect of oxygenation level. *Water Res.*, **40**, 2972–2980.
26. Kampschreur M.J., Temmink H., Kleerebezem R. et al. (2009) Nitrous oxide emission during wastewater treatment. *Water Res.*, **43**, 4093–4103.
27. Toyoda S and Yoshida N. (1999) Determination of nitrogen isotopomers of nitrous oxide on a modified isotope ratio mass spectrometer. *Anal Chem.*, **71**, 4711–4718.
28. Toyoda S., Kuroki N., Yoshida N. et al. (2013) Decadal time series of tropospheric abundance of N₂O isotopomers and isotopologues in the Northern Hemisphere obtained by the long-term observation at Hateruma Island, Japan. *J. Geophys. Res. Atmos.*, **118**, 3369-3381.
29. Sigman D.M., Casciotti K.L., Andreani M. et al. (2001) A bacterial method for the nitrogen isotopic analysis of nitrate in seawater and freshwater, *Anal. Chem.*, **73**, 4145–4153.
30. Casciotti K.L., Sigman D.M., Hastings M.G. et al. (2002) Measurement of the oxygen isotopic composition of nitrate in seawater and freshwater using the denitrifier method. *Anal. Chem.*, **74**, 4905–4912.
31. Weiss R.F., Price B.A. (1980) Nitrous oxide solubility in water and seawater. *Mar. Chem.*, **8**, 347–359.
32. Kampschreur M.J., Tan N.C.G., Kleerebezem R. et al. (2008a) Effect of dynamic process conditions on nitrogen oxides emission from a nitrifying culture. *Environ. Sci. Technol.*, **42**, 429–435.
33. Zheng H., Hanaki K., Matsuo T. (1994) Production of nitrous oxide gas during nitrification of wastewater. *Water Sci. Technol.*, **30**, 133-141.
34. Yamagishi H., Westley M.B., Popp B.N. et al. (2007) Role of nitrification and denitrification on the nitrous oxide cycle in the eastern tropical North Pacific and Gulf of California. *J. Geophys. Res.*, **112**, G02015.
35. Koba K., Osaka K., Tobar Y. et al. (2009) Biogeochemistry of nitrous oxide in groundwater in a forested ecosystem elucidated by nitrous oxide isotopomer measurements. *Geochim. Cosmochim. Acta*, **73**, 3115–3133.
36. Inoue H.Y and Mook W.G. (1994) Equilibrium and kinetic nitrogen and oxygen isotope fractionations between dissolved and gaseous N₂O. *Chem. Geol.*, **113**, 135–148.
37. Mariotti A., Germon J.C., Hubert P. et al. (1981) Experimental determination of nitrogen kinetic isotope fractionation: some principles; illustration for the denitrification and nitrification processes. *Plant Soil.*, **62**, 413–430.
38. Frame C.H., Casciotti K.L. (2010) Biogeochemical controls and isotopic signatures of nitrous oxide production by a marine ammonia-oxidizing bacterium. *Biogeosciences*, **7**, 2695–2709.
39. Ostrom N.E., Pitt A., Sutka R. et al. (2007) Isotopologue effects during N₂O reduction in soils and in pure cultures of denitrifiers. *J. Geophys. Res.*, **112**, G02005.