

# A NOTE ON CELL WALL AND WOOD SUBSTANCE DENSITIES

*F. C. Beall*

Wood Products R & D, Weyerhaeuser Company, Tacoma, WA 98477

(Received March 1983)

## ABSTRACT

The differences in reported values of material densities for wood are discussed and analyzed with respect to cell-wall voids. A model is proposed to account for the reported differences and for general use in calculating relationships between wood volume and density.

*Keywords:* Cell-wall density, wood substance density, cell-wall voids, sorption compression.

Values for the density of wood substance reported in the literature are confusing since they vary with the measuring fluid. For example, Weatherwax and Tarkow (1968) report 1.465 g/cm<sup>3</sup> for silicone and 1.546 for water. There are a number of possible explanations for the differences, but all can be categorized as resulting from assumptions of 1) densification or "sorption compression" of water, 2) cell-wall voids, and 3) a combination of both. For assumption 1, the effective density of sorbed water can be calculated from the difference in specific volumes of wood ( $\Delta\bar{V}$ ) using silicone (0.6826) and water (0.6468) and assuming a FSP of 27%:

$$\rho_{sw} = \frac{m}{V} = \frac{0.27}{0.27 - \Delta\bar{V}} = 1.153$$

Therefore, we assume that the true density of "wood substance" is that measured with silicone, and that the value obtained using water is an artifact caused by "densification" of water. For assumption 2, we can assume the opposite hypothesis, that is, densification of water does *not* occur and the true density is that obtained using water. This requires that we attribute the lower density in silicone to incomplete cell-wall penetration, or the presence of unpenetrated cell-wall voids. Assumption 3 can be used to advocate any intermediate density, depending on an assumed fraction of cell-wall voids. The dilemma is in choosing which density to use; however, there are some interesting data published by Weatherwax and Tarkow from which to propose a feasible explanation.

Assume (a) for density obtained with water, that no cell-wall voids persist because of total swelling and penetration by the water, and that densification of sorbed water does not occur, and (b) the "cell-wall voids" are at some maximum value during silicone displacement. If we plot the density values (1.465 and 1.546) against an assumed cell-wall void volume fraction (Fig. 1), then it should be possible to test this relationship for some intermediate density. Weatherwax and Tarkow also determined the density of wood substance using hexane through a solvent-exchange series (water/alcohol/hexane) to reach the final condition, and, according to the authors, "about an 18% reduction in absolute swelling occurs in hexane replacement." From Fig. 1, their density value of 1.533 for hexane predicts

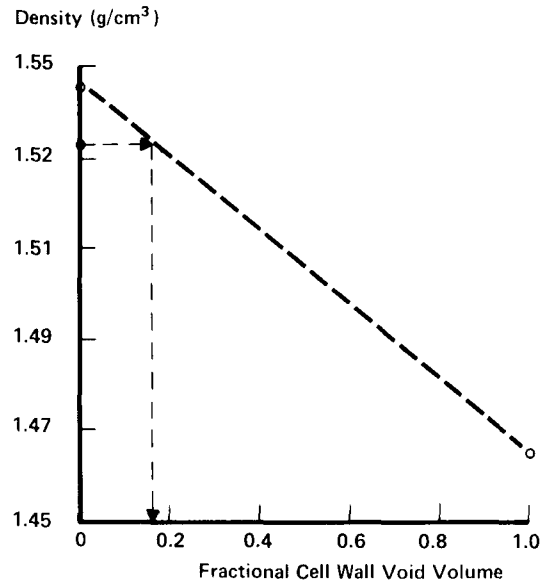

FIG. 1. Relationship of cell wall or wood substance density with assumed cell-wall void fraction.

a fractional cell wall void volume of 0.16. Within the margin of experimental error (since the swelling reduction was not measured during their data collection), the assumed 18% swelling reduction is essentially equal to the predicted 16% fractional cell-wall void volume. This interpretation requires an acceptance that the volume of cell-wall voids are directly related to degree of penetration of fluid into and consequent swelling of the cell wall.

Based on this analysis, the following concepts are proposed:

1. The “true” wood substance density ( $\rho_{ws}$ ) is that which is measured in water, assuming no “densification” of sorbed water.
2. The density value obtained for oven-dry wood in nonswelling fluids is the cell-wall density ( $\rho_{cw}$ ). This assumes that a solvent exchange method (which would swell the cell wall) is not used in the determination.

These concepts are shown schematically in Fig. 2. Model 1 for oven-dry wood shows the cell-wall volume ( $V_{cw}$ , which includes the cell-wall void volume). Model 2 shows the wood substance volume ( $V_{ws}$ ), assuming *no* sorption compression. For those believing in sorption compression, model 3 is shown (in which case you get stuck with having to call my  $V_{cw}$  your wood substance volume). The models can also be used for calculating other relationships such as density of the swollen cell wall, the maximum moisture content, and fractional void volumes at any moisture content. In some of these cases,  $V_{FW}$  (volume of free water) is substituted for at least a portion of  $V_v$ .

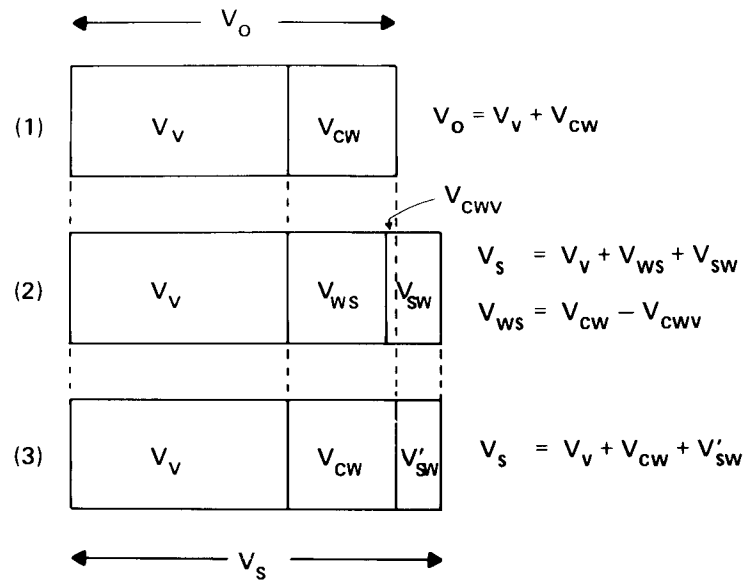

- $V_o$  = Oven-dry Gross Volume  
 $V_s$  = Swollen Volume  
 $V_v$  = Void Volume (Except for Internal Cell Wall Voids)  
 $V_{cw}$  = Cell Wall Volume  
 $V_{ws}$  = Wood Substance Volume  
 $V_{sw}$  = Sorbed Water Volume  
 $V'_{sw}$  = "Compressed" Sorbed Water Volume  
 $V_{cwv}$  = Cell Wall Void Volume

FIG. 2. Models for wood substance, cell-wall substance, and voids in oven-dry and swollen wood.

#### REFERENCE

- WEATHERWAX, R. C., AND H. TARKOW. 1968. Density of wood substance—importance of penetration and adsorption compression of the displacement fluid. For. Prod. J. 18(7):44-46.