

MATHEMATICAL DESCRIPTION OF THE CHANGE IN  
PROPERTIES OF *CASUARINA* WOOD UPON EXPOSURE  
TO GAMMA RADIATION. 1. CHANGES IN THE  
COMPRESSIVE AND TENSILE STRENGTH

*M. Lotfy M. El-Osta*<sup>1</sup>

Associate Professor of Wood Technology  
Faculty of Agriculture, Alexandria University, Alexandria, Egypt

*A. A. El-Miligy*

Professor of Radiation Chemistry  
National Center for Radiation Research and Technology, Egypt

*S. E. Kandeel*

Professor of Wood Technology  
Faculty of Agriculture, Alexandria University, Alexandria, Egypt

*M. H. El-Lakany*

Associate Professor of Forestry  
Alexandria University, Alexandria, Egypt

and

*M. M. El-Morshedy*

Formerly Graduate Student  
Faculty of Agriculture, Alexandria University, Alexandria, Egypt

(Received July 1982)

ABSTRACT

*Casuarina cunninghamiana* specimens were exposed to gamma-radiation doses ranging from  $10^4$  to  $10^8$  rad and tested in compression and tension parallel to grain. The percentage values of the irradiated specimens relative to that of the matched control (Y) were determined. The relationship between (Y) and log gamma radiation dose (X) was represented mathematically by the equation:  $Y = aX^b$ . This equation described the change in compressive and tensile strength very well as was detected from the high correlation coefficients. Generally these properties increased slightly at low levels of radiation, reached a maximum, then decreased gradually thereafter. The reduction in tensile strength was more pronounced than in compressive strength.

The threshold dose, i.e., the dose beyond which the properties began to decrease, was calculated. This dose ranged from  $3.69 \times 10^6$  to  $3.76 \times 10^6$  rad for compressive strength properties and from  $1.51 \times 10^6$  to  $1.70 \times 10^6$  rad for tensile strength properties. This indicated that irradiated casuarina wood had a greater resistance to compression than to tension.

*Keywords:* *Casuarina cunninghamiana*, gamma radiation, property changes, tensile strength, compression.

---

<sup>1</sup> Currently Associate Professor of Wood Technology, College of Agriculture, University of Riyadh, Riyadh, Saudi Arabia.

## INTRODUCTION

Radiation has been extensively used as a tool in wood research and technology. Interest has been in all of the common forms of radiation energy, i.e., alpha rays, beta rays, and machine produced X-rays. Gamma radiation has been useful in measurements of certain physical properties, nondestructive testing of wood, utility pole inspection, sterilization of wood to impart fungi and insect resistance, and as a means of polymerizing other polymers in wood to alter and/or improve its physical and mechanical properties. The changes induced by gamma radiation in wood are, therefore, of interest for practical wood utilization as well as for the purely theoretical point of view.

Reports in the literature indicate that upon exposure to gamma-irradiation, the chemical constituents of wood undergo certain changes (Barton 1966; Frejdin 1958; Saeman et al. 1952; Seifert 1964; Smith and Mixer 1959; Tabirih et al. 1977) that are best reflected by its anatomical and mechanical properties (Becker and Burmester 1962; Burmester 1964; El-Osta et al. 1979; Loos 1962; Shuler 1971; Shuler et al. 1975; Tabirih et al. 1977). The magnitude of these changes depends on the dose level, wood species, and the examined strength property.

*Casuarina cunninghamiana* Miq. is one of the most common fast-growing species in Egypt. It is a good source for wood raw material. Its uses have recently been expanded because of the increase in the prices of imported woods. The possibility exists for upgrading the properties of this wood by producing wood/plastic composites. Accordingly, it is of interest to examine the changes in its properties upon exposure to gamma radiation. The objective of this study, therefore, was to measure and describe mathematically the change in compressive and tensile strength of *Casuarina cunninghamiana* wood upon exposure to gamma radiation.

## MATERIALS AND METHODS

*Specimen preparation*

The experimental material was chosen from a 21-year-old *Casuarina cunninghamiana* tree grown at the experiment station of the Faculty of Agriculture, Abiss, near Alexandria city. It was 55 cm in diameter at breast height and 14 m high. It had a straight stem and was free from natural defects. After the tree was felled, two 60-cm bolts were removed, one at 80 cm and the other at 140 cm from the stump-height level. The bolts were machined into a number of sticks (nominal 5 cm tangentially, 2.5 cm radially, and 50 cm longitudinally) as depicted in Fig. 1, and then they were air-dried.

*Preparation of compression test specimens.*—Sticks assigned for compression test were machined into pairs of tangentially matched sticks (nominal 2 by 2 cm in cross section). One of the matched sticks was used for control, whereas the other was exposed to gamma irradiation. Each stick was then divided into a number of compression test specimens (2 cm radially and tangentially and 6 cm longitudinally) according to British Standard Institutions No. 273 (1957). The net yield of specimens was 70, half of which were gamma irradiated.

*Preparation of tensile test specimens.*—Each stick assigned for tensile test was machined into two tangentially matched sticks (nominal 2.5 cm radially and tangentially, and 50 cm longitudinally) as shown in Fig. 1. Then each small stick

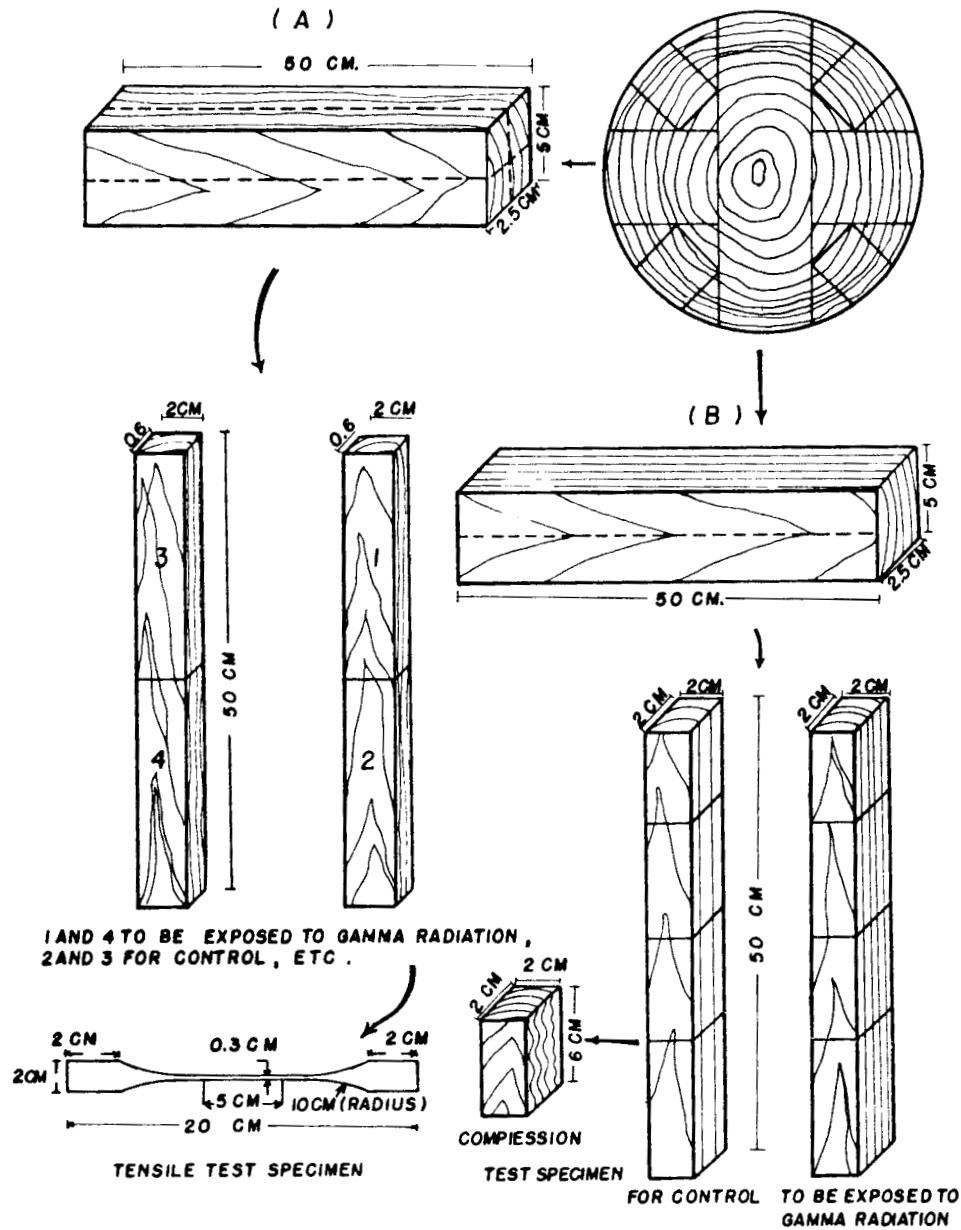

FIG. 1. Schematic representation of the procedure used in preparing (A) compression and (B) tensile test specimens.

was further divided into two radially matched specimens (nominal 0.6 cm radially, 2 cm tangentially, and 50 cm longitudinally). Each was divided into 20-cm-long specimens; one was assigned for control and the other for exposure to gamma irradiation. The specimens were finally machined into the shape and dimensions

shown in Fig. 1. The net yield of specimens was 72, half of which was gamma irradiated.

#### *Irradiation procedure*

A cobalt-60 source of gamma cell 220 type, installed at the National Center for Radiation Research and Technology (NCRRT), Atomic Energy Establishment, Egypt, was used for the irradiation process. It had a dose rate of 0.135 M rad/h.

The specimens to be irradiated were placed approximately in the center of the gamma cell. The irradiation doses to which the specimens were subjected ranged from  $10^4$  to  $10^8$  rad. After irradiation, specimens were kept in the laboratory until they reached equilibrium moisture content.

#### *Testing procedure*

*Compression test parallel to grain.*—Compression test was carried out using a floor model Instron testing machine, model 1195, at the Material Testing Laboratory, NCRRT. The load was applied at a cross-head speed of 0.5 mm/min. The load-deformation diagram was obtained and the mode of failure recorded. Small samples were obtained from each test piece for determining specific gravity (SG) and moisture content (MC). The SG was calculated based upon volume at test and oven-dry weight. Upon completion of the test, maximum crushing strength (MCS) was calculated.

*Tensile test parallel to grain.*—Tensile test parallel to grain was carried out using the Instron testing machine and according to the British Standard Institutions No. 273 (1957). The load was applied to test specimen at a cross-head speed of 1.0 mm/min until failure. The mode of failure and its position were recorded for each specimen. Tensile stress at proportional limit (TSPL) and at maximum load (TSML) were then calculated.

The two portions, removed from the test specimens during machining, were used for determining MC and SG. Because of the irregular shape of the specimen, SG was determined using the maximum moisture content method (Smith 1954).

#### *Data analysis*

The following equation was chosen for describing the change in compressive and tensile strength properties upon exposure to gamma-irradiation doses:

$$Y = aX^b c^X \quad (1)$$

where:

Y = percentage value of irradiated specimen relative to that of the control,

X = log of gamma dose, and

a, b, c = constants.

Equation (1) can be transformed as follows:

$$\text{Log } Y = \text{log } a + b \text{ log } X + X \text{ log } c \quad (2)$$

and can be written in the following form:

$$\text{Log } Y = B_0 + B_1 \text{log } X + B_2 X \quad (3)$$

where:

$$B_0 = \text{Log } a, B_1 = b, \text{ and } B_2 = \log c$$

An IBM computer program for regression analysis with the least squares method fit was used to fit the data to Eq. (3) and to estimate its constants.

The form of the chosen equation made it possible to determine the gamma radiation dose at which the maximum increase in the strength properties occurred. Therefore, the following derivation was made.

Since:

$$\begin{aligned} Y &= aX^b c^X \\ dY/dX &= a(X^b c^X \ln c + c^X b X^{b-1}) \\ &= aX^b c^X (\ln c + b/X) \end{aligned}$$

The maximum value of this function is obtained when  $dY/dX = 0$ .

Therefore,

$$aX^b c^X (\ln c + b/X) = 0$$

Accordingly:

$$X = -\frac{b}{\ln c} \quad (4)$$

Equation (4) was used for calculating the dose that gave the highest increase in the strength properties.

The threshold dose, i.e., the gamma radiation dose beyond which strength properties begin to decrease, was determined. At this point, the value of the irradiated specimen relative to that of the control equals unity. Therefore, Eq. (1) was used with an iterative procedure for calculating the threshold dose for each property.

## RESULTS AND DISCUSSION

### *Change in compressive strength properties*

Experimental average values for MC, SG, MCS, and specific MCS at different gamma-irradiation doses are presented in Table 1. The values of strength properties were adjusted for differences in MC, based on the simple regression developed for each property. The MCS of irradiated sample (I) divided by that of the control (C) multiplied by 100 was used as an expression for representing the change due to radiolysis of wood.

The mathematical equations that describe the change in the compressive strength properties along with the correlation coefficients are summarized in Table 2. The high correlation coefficients presented in this table indicate that the mathematical equation chosen is suitable for representing the change in compressive strength properties due to exposure to gamma doses. Using this equation made it possible to describe the increase in compressive strength properties at low gamma-radiation doses used and the observed decrease at the higher doses.

*Gamma-irradiation dose associated with the highest strength increase.*—Equation (4) was used to calculate the dose at which the highest increase in MCS and

TABLE 1. Experimental average values for moisture content (MC), specific gravity (SG), maximum crushing strength (MCS), and specific MCS of gamma-irradiated casuarine wood.

No. of samples <sup>a</sup>	Dose (Mrad)	MC	SG <sup>b</sup>	MCS (kg/cm <sup>2</sup> )	I/C × 100	Specific MCS (kg/cm <sup>2</sup> )	I/C × 100
4I	0.01	13.28	0.533	295	109	555	108
4C		13.67	0.527	271		514	
4I	0.10	13.52	0.534	288	107	540	108
4C		13.81	0.530	269		499	
4I	0.50	13.80	0.546	315	110	578	108
4C		13.78	0.539	287		533	
7I	3.40	13.01	0.521	307	109	576	107
7C		13.25	0.522	282		540	
5I	5.80	13.15	0.543	328	107	605	106
5C		13.75	0.539	307		569	
7I	50.00	10.02	0.527	180	62	341	62
7C		14.66	0.525	289		551	
4I	100.00	10.04	0.560	178	62	315	60
4C		14.54	0.545	286		525	

<sup>a</sup>I = value of the irradiated sample. C = value of the control.

<sup>b</sup>SG is based upon volume at test and oven-dry weight.

TABLE 2. Mathematical equations for the change in maximum crushing strength (MCS), specific MCS, tensile strength at maximum load (TSML), specific TSML, tensile strength at proportional limit (TSPL), and specific TSPL due to radiolysis of casuarina wood.

Equation	N	R <sup>2</sup>
$\text{Log } Y_1 = 0.35 + 6.27 \log D - 0.53D$	35	0.826**
$\text{Log } Y_2 = 0.26 + 6.59 \log D - 0.55D$	35	0.848**
$\text{Log } Y_3 = -2.67 + 17.54 \log D - 1.49D$	36	0.812**
$\text{Log } Y_4 = -2.65 + 17.51 \log D - 1.49D$	36	0.821**
$\text{Log } Y_5 = -1.73 + 14.04 \log D - 1.19D$	36	0.803**
$\text{Log } Y_6 = -1.68 + 13.95 \log D - 1.19D$	36	0.830**

$Y_1, Y_2, Y_3, Y_4, Y_5$  and  $Y_6$  represent MCS, specific MCS, TSML, specific TSML, TSPL and specific TSPL as a percent of the control respectively.

D = log gamma radiation dose.

N = number of measurements.

R = correlation coefficient.

\*\* Significant at the 1% level of probability.

TABLE 3. Gamma-irradiation doses that gave the highest strength increase.

Strength property	Irradiation dose (rad)
Maximum crushing strength (MCS)	$0.138 \times 10^6$
Specific MCS	$0.143 \times 10^6$
Maximum tensile strength (TSML)	$0.130 \times 10^6$
Specific TSML	$0.129 \times 10^6$
Tensile strength at prop. limit (TSPL)	$0.130 \times 10^6$
Specific TSPL	$0.126 \times 10^6$

TABLE 4. *Threshold doses for compressive and tensile strength properties.*

Strength property	Irradiation dose (rad)
Maximum crushing strength (MCS)	$3.76 \times 10^6$
Specific MCS	$3.69 \times 10^6$
Maximum tensile strength (TSML)	$1.51 \times 10^6$
Specific TSML	$1.60 \times 10^6$
Tensile strength at prop. limit (TSPL)	$1.64 \times 10^6$
Specific TSPL	$1.70 \times 10^6$

specific MCS occurred. The results of these calculations are given in Table 3. They are lower than those reported by others (Becker and Burmester 1962; Burmester 1964; El-Osta et al. 1979; Karpov et al. 1960; Loos 1962; Seifert 1964). This may be due to the fact that casuarina wood is different chemically and anatomically from other woods.

*Threshold dose.*—Calculated threshold doses are presented in Table 4. These doses ranged from  $3.76 \times 10^6$  rad for MCS to  $3.69 \times 10^6$  rad for specific MCS. Estimating these doses is very important if casuarina wood is to be exposed to gamma irradiation during processing of wood/plastic composites.

#### *Change in tensile strength properties*

Experimental average values for MC, SG, and tensile strength properties of the control and treated specimens are shown in Table 5. The percentage values of the treated specimens relative to those of the controls are also presented in this table.

TABLE 5. *Experimental average values for moisture content (MC), specific gravity (SG) and tensile strength properties of gamma-irradiated casuarina wood.*

No. of samples <sup>a</sup>	Dose (Mrad)	MC	SG <sup>b</sup>	TSMML <sup>c</sup>		Specific TSMML <sup>c</sup>		TSPL <sup>d</sup>		Specific TSPL <sup>d</sup>	
				(kg/cm <sup>2</sup> )	I/C × 100	(kg/cm <sup>2</sup> )	I/C × 100	(kg/cm <sup>2</sup> )	I/C × 100	(kg/cm <sup>2</sup> )	I/C × 100
4I	0.01	13.69	0.478	701	104	1,466	106	360	101	754	104
4C		13.24	0.489	677		1,385		356		728	
4I	0.10	14.58	0.468	655	105	1,396	107	423	118	899	121
4C		13.53	0.479	626		1,310		358		745	
6I	0.50	13.99	0.442	522	105	1,185	106	284	104	642	104
6C		14.02	0.443	498		1,122		274		617	
5I	1.00	13.26	0.470	585	90	1,290	96	367	95	791	99
5C		13.21	0.485	649		1,338		388		800	
5I	3.40	13.84	0.475	566	100	1,190	101	409	98	860	97
5C		14.26	0.483	567		1,178		418		887	
4I	6.50	12.50	0.485	521	83	1,079	82	363	86	773	87
4C		13.11	0.473	627		1,318		421		885	
4I	10.00	12.90	0.485	423	79	872	78	286	87	589	85
4C		13.32	0.479	538		1,121		329		689	
4I	100.00	13.36	0.486	82	13	169	13	78	19	161	19
4C		12.92	0.491	646		1,319		405		826	

<sup>a</sup> I = value of the irradiated sample. C = value of the control sample.

<sup>b</sup> SG is determined by the maximum moisture content method.

<sup>c</sup> TSMML = tensile strength at maximum load.

<sup>d</sup> TSPL = tensile strength at proportional limit.

The values of the tensile strength properties were adjusted for differences in MC based on the simple regression developed for each property.

The mathematical equations that describe the change in the tensile strength properties along with the correlation coefficients are summarized in Table 2. Examining this table reveals that the equations describe the change reasonably well as indicated by the high correlation coefficients.

*Gamma-irradiation dose associated with the highest strength increase.*—Equation (4) was used to calculate the dose at which the highest increase in tensile strength properties occurred. The results of these calculations are presented in Table 3. The doses ranged from  $1.26 \times 10^5$  rad for TSPL to  $1.3 \times 10^5$  rad for TSML.

*Threshold dose.*—Equation (1) was used to calculate the threshold dose (Table 4). These doses ranged from  $1.51 \times 10^6$  rad in the case of specific TSPL.

It should be indicated that the threshold doses for the compressive strength properties were generally 2 to 2.5 times higher than those for tensile strength properties (Table 4). This result is expected, for each of the above strength properties is controlled by different wood constituents, i.e., cellulose and hemicelluloses in the case of tension and lignin in the case of compression. Lignin, with its aromatic structure, has higher resistance to radiolysis than cellulose and hemicelluloses (Barton 1966; Burmester 1964; Karpov et al. 1960; Seifert 1964; Smith and Mixer 1959). This is why irradiated specimens had greater resistance to compression than to tension. This is further supported by the observed greater reduction in tension than in compression at a dose level of  $10^8$  rad (Tables 1 and 5).

#### CONCLUSIONS

From the results of this study the following conclusions are drawn:

1. Compressive and tensile strength properties parallel to grain increased slightly at the first low doses ranging from  $10^4 \times 10^5$  to  $1.4 \times 10^5$  rad, reached a maximum, and decreased thereafter.
2. The mathematical equation  $Y = aX^bc^X$ , where  $X = \log$  gamma dose and  $Y =$  the percentage of the value of irradiated specimen relative to the control, was found to be suitable for describing the change in the above properties due to exposure to gamma radiation.
3. Compressive strength properties showed greater resistance to gamma radiation effect than those for tensile strength. This was evident from the calculated threshold dose at which these properties began to decrease. It ranged from  $3.69 \times 10^6$  to  $3.76 \times 10^6$  rad for compressive strength properties and from  $1.51 \times 10^6$  to  $1.69 \times 10^6$  rad for tensile strength properties.

#### REFERENCES

- BARTON, G. M. 1966. Chemical and physical effects of radiation on wood. Internal Rep. Can. Dep. For. Rural Develop. Forest Prod. Lab. Vancouver, BC, Canada. 9 pp.
- BECKER, G., AND BURMESTER. 1962. Change in wood properties by gamma-irradiation. *Materialpruf* 4:416-426. Univ. of British Columbia, Fac. of Forestry, translation No. 40, Vancouver, BC, Canada.
- BRITISH STANDARD INST. (B.S.I.). 1957. British standard methods for testing small specimens of timber. British Institutions. Bull. No. 273, London.



- BURMESTER, A. 1964. Change in compressive and tensile strength as well as sorption of wood caused by gamma-irradiation. *Materialpruf.* 6:95-99. Univ. of British Columbia, Fac. of Forestry, translation No. 35, Vancouver, BC, Canada.
- EL-OSTA, M. L., A. A. EL-MILIGY, O. A. BADRAN, AND M. M. EL-MORSHEDY. 1984. Effects of gamma-irradiation on crushing strength of four hardwoods. (In press).
- FREJDIN, A. S. 1958. Effect of radioactive radiation on physico-mechanical properties of wood. *Derevo Prom* 7(9)13. CSIRO, translation No. 4417, Australia.
- KARPOV, V. L., I. M. MOLINSKY, V. I. BERENKOV, B. S. KLIMANOVA, AND A. S. FREJDIN. 1960. Radiation makes better wood and copolymers. *Nucleonics* 18(3):88-90.
- LOOS, W. E. 1962. Effect of gamma-irradiation on the toughness of wood. *For. Prod. J.* 12(6):261-264.
- SAEMAN, J. F., M. A. MILLETT, AND E. J. LAWTON. 1952. Effects of high energy cathode rays on cellulose. *Ind. Eng. Chem.* 44:2848-2852.
- SEIFERT, K. 1964. On the chemistry of gamma-irradiated wood. *Holz Roh. Werkst.* 22:267. Univ. of British Columbia, Fac. of Forestry, translation No. 28, Vancouver, BC, Canada.
- SHULER, C. E. 1971. Gamma-irradiation effects on modulus of elasticity of Engelmann spruce. *For. Prod. J.* 21(7):49-51.
- , J. E. SHOTTAFAER, AND R. J. CAMPANA. 1975. Effect of gamma-irradiation in vivo on the flexural properties of American elm. *Wood Sci.* 7(3):209-212.
- SMITH, D. M. 1954. Maximum moisture content method for determining specific gravity of small wood samples. USDA, Forest Prod. Lab. Rep. 2014. 8 pp.
- , AND R. Y. MIXER. 1959. The effect of lignin on the degradation of wood by gamma-irradiation. *Radiat. Res.* 11:776-780.
- TABIRIH, P. K., E. A. MCGINNES, JR., M. A. KAY, AND C. A. HARLOW. 1977. A note on anatomical changes of white oak upon exposure to gamma-irradiation. *Wood Fiber* 9(3):211-215.