

# THE EFFECT OF END DISTANCE AND NUMBER OF READY-TO-ASSEMBLE FURNITURE FASTENERS ON BENDING MOMENT RESISTANCE OF CORNER JOINTS

*Milan Simek*<sup>†</sup>

Research Assistant  
Department of Furniture, Design and Habitation  
Mendel University of Agriculture and Forestry Brno  
Zemedelska 3, Brno, 613 00, Czech Republic

*Eva Haviarova*<sup>\*†</sup>

Assistant Professor

*Carl Eckelman*

Professor  
Department of Forestry and Natural Resources  
Purdue University  
West Lafayette, IN 47907

(Received June 2009)

**Abstract.** Although they are widely used by the furniture industry, ready-to-assemble (RTA) furniture fasteners are a relatively new style of joinery. The object of this study was to investigate the effect of end distance of cam-lock RTA fasteners and nonglued wooden dowels on the splitting and bending moment resistance, respectively, of RTA corner joints. Laminated particleboard, cam fasteners, and wooden dowels were used for specimen construction (as used in the furniture industry). In two studies, L-shaped joint specimens 760 mm long were tested in compression. The first study showed that end splits in panels were eliminated when cam fasteners were located 60 mm from the member ends. In the second study, specimens with two cam fasteners supported by 2, 3, 4, or 5 nonglued dowels were tested. These specimens had significantly higher bending moment resistance than comparable joints that used only cam fasteners but no dowels. Thus, it was concluded that unglued dowels used to position parts for assembly substantially reinforce joints constructed with cam fasteners.

**Keywords:** Bending moment resistance, furniture joint, end distance, laminated particleboard, cam fastener, nonglued wooden dowel.

## INTRODUCTION

Fasteners for ready-to-assemble (RTA) furniture have been developed and used for almost half a century. There are numerous types of RTA connectors, including mechanical cam locking, screw-in, bolt-tightening, bracket, and hooks. In the case of cam-based construction, two connectors placed near the ends of the members to be joined provide mechanical strength with intermediate unglued dowels spaced along the edge

of the members to help locate and permanently position them. To obtain a visually tight closing of the ends of the joints, it is important that the cams be located near the ends of the members. Placement of the cams too close to the ends, however, can seriously affect the structural integrity of the joint. It is important, therefore, to determine the minimum edge placement distance that will allow development of maximum joint strength. Furthermore, it is to be expected that unglued dowels would increase the bending moment capacity of the joint, although it appears reasonable to assume that use of too many dowels might actually

\* Corresponding author: [ehaviar@purdue.edu](mailto:ehaviar@purdue.edu)

<sup>†</sup> SWST member

weaken the capacity of a joint. Hence, information concerning both issues is needed to rationally design such joints. Previously reported research provides some guidance with regard to both issues.

In tests carried out with joints constructed with 8-mm-dia dowels, Bachmann and Hassler (1975) found that for all practical purposes, the capacities of joints increased regularly when constructed with 1 to 4 dowels provided they were spaced no closer together than 100 mm.

Albin *et al.* (1987) carried out extensive tests on corner joints constructed both with adhesive-based and mechanical fasteners. Overall, they found that the capacity of the joints varied substantially depending on the type of fastener along with the quality of particleboard in the specimens. They also found that in the case of mitered corner joints, results are strongly affected by the method of loading.

Rajak (1989) found that the most consistent testing results were obtained when joints were loaded in compression. With 5-, 5.5-, and 6-mm-dia screws, the average length of the split that developed in the edge of the board as the specimen failed was between 90 and 100 mm, which is the “zone of influence” of the screw. Thus, in joints constructed with multiple fasteners, maximum bending moment capacity is obtained when fasteners are spaced at least 90 to 100 mm apart. Furthermore, Rajak found that to prevent end splits when screws were inserted into pilot holes, 5-mm screws should be located at least 25 mm from the end of the board, 5.5-mm screws no less than 37 mm, and 6-mm screws no less than 50 mm. Finally, when the “zones of influence” do not overlap, Rajak and Eckelman (1996) found that bending moment capacity increased in direct proportion to the number of screws.

In related work with dowels, Zhang and Eckelman (1993a) found that bending moment capacity of single-pin corner joints substantially increased as dowel diameter increased 6.4 – 8 – 9.5 mm. Subsequent work by Zhang and Eckelman (1993b) with multiple dowel joints

indicated that highest bending moment capacities are obtained when spacing between dowels is at least 75 mm. Likewise, in cyclic tests of cases constructed with screws, Ho and Eckelman (1994) found that maximum racking resistance was obtained with screw spacings of 75 – 90 mm. Subsequent research by Liu and Eckelman (1998) conducted on corner joints, with up to 36 fasteners per joint, clearly demonstrated that for either glued dowels or screws, bending moment capacity of the joints decreased as spacing between fasteners decreased below 60 mm.

There are other investigations of RTA fastener joint strength such as those by Smardzewski and Prekrad (2002), Joscak and Cernok (2002), and Tankut (2006), but in general, their research was not conducted specifically to determine the effect of edge distance on joint strength or the extent to which the load capacity of the cam fasteners is augmented by the use of positioning dowels. The purpose of this study, accordingly, was to obtain information specific to these questions that could be used by furniture manufacturers in rational design of such joints.

## OBJECTIVES

The first objective of this article was to determine the spacing of cams from the edge of joints needed to eliminate end splits. The second objective was to determine the contribution of the number and positioning of nonglued dowels to the bending moment capacity of cam-connected corner joints.

## MATERIALS AND JOINT DESIGNS

All joint specimens were constructed from 19-mm-thick particleboard laminated with melamine foil. The panels were tested (Table 1) for density, MC, internal bond, modulus of elasticity (MOE), and modulus of rupture (MOR) in accordance with ASTM D1037 (ASTM 2002). Small cam fasteners (Fig 1), 15-mm dia, were chosen for this study. Multigrooved 8-mm-dia

Table 1. Physical and mechanical properties of laminated particleboard used in the tests.

Density	MC	Modulus of rupture	Modulus of elasticity	IB
(kg/m <sup>3</sup> )	(%)	(MPa)	(GPa)	(MPa)
704 (2.4)*	6.7 (2.0)	25.4 (13.0)	2.60 (12.1)	0.48 (19.5)

COV, coefficient of variation in %.



Figure 1. Cam fasteners (metal connecting bolts, cam housings) and multigrooved wooden dowels used in tests.

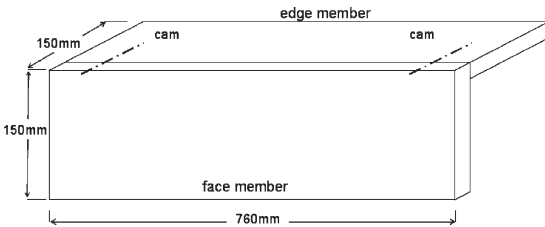

Figure 2. General configuration of corner joint specimen used to evaluate effect of the end position of cam fasteners.

and 35-mm-long beech dowels were used in combination with cam fasteners.

The configuration of the corner joint specimens in the first study is shown in Fig 2. Each specimen consisted of a face and edge member that were joined together with two cam connectors. Specimens with three cam distances (30, 60, and 90 mm) from the end of members (Fig 3) were tested (18 replications each) to determine the most effective end position.

Holes of 15-mm dia and 14.5-mm depth were drilled into the face of the edge members for cam housings. Connecting holes for 8-mm-dia bolts were drilled into edge members. Pilot holes of 5-mm dia and 12-mm depth were drilled into face members for the threaded part of the bolts. Then holes for 8-mm wooden dowels were drilled into the edge member (22-mm deep) and face member (14-mm deep). A torque wrench was used to tighten the bolts to 3 N·m; after the

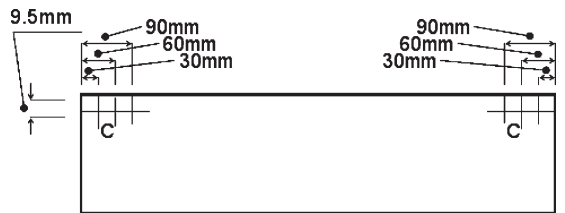

Figure 3. Face member with distances where the connectors (C = cam fastener) were placed in the first study.

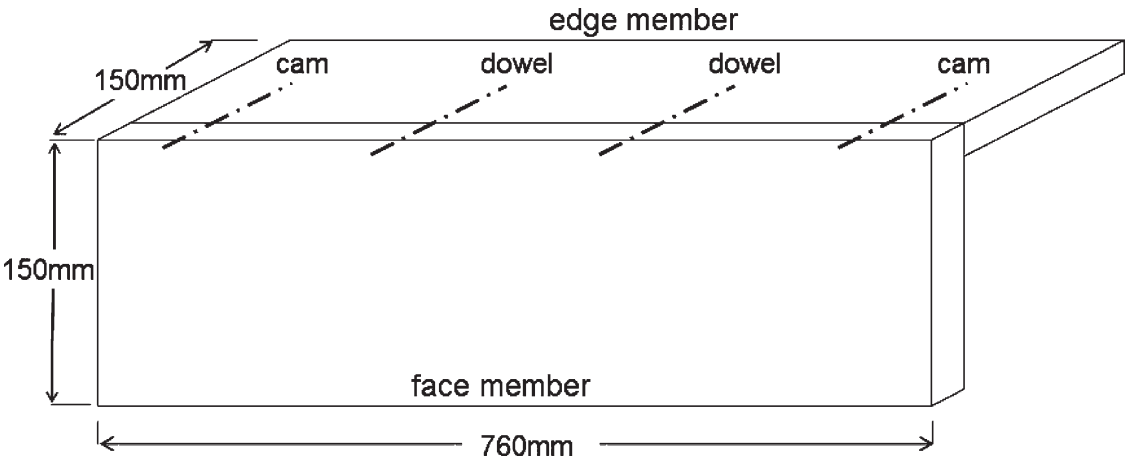

Figure 4. General configuration of corner joint specimen used to evaluate the effect of dowels on bending moment resistance.

bolts were inserted in the cams, the cams were tightened to 4 N·m.

The general configuration of the corner joint specimens used in the second study is shown in Fig 4. The best end distance, “a” (60 mm), for placement of the cams (Fig 5), as determined in the first study, was used for all specimens. Six

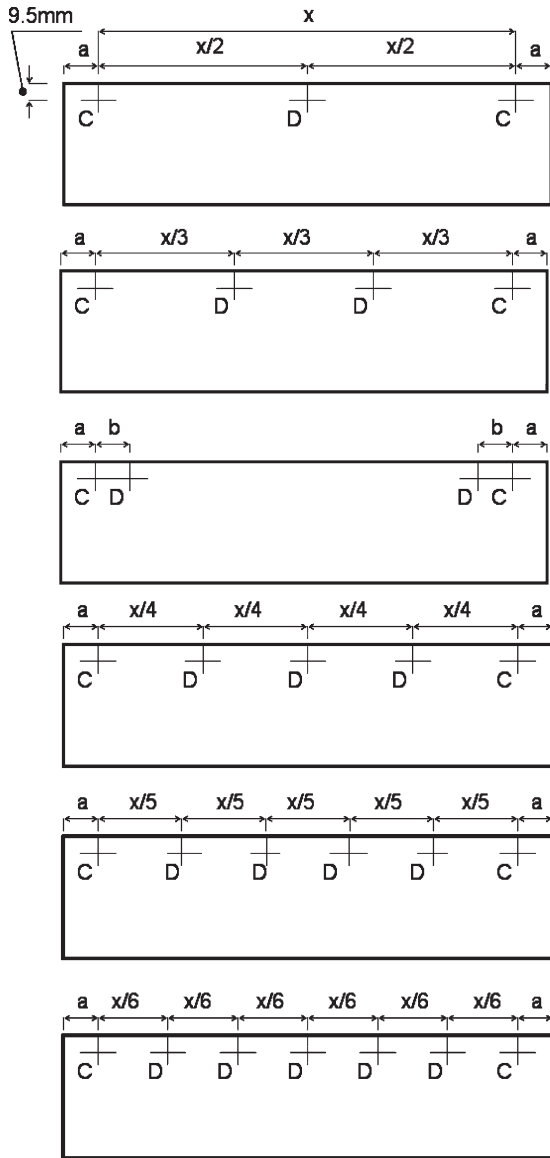

Figure 5. Face members with distances where the connectors (C = cam fastener, D = dowel) were placed in the second study.

specimen variations were constructed with 2 cam fasteners and 1 to 5 dowels (12 replications each) per specimen. Five of the six specimen variations were constructed with equal dowel spacing as shown in Fig 5, whereas the sixth variation was constructed with two unequally spaced dowels (Fig 5) because of its common use by manufacturers. The cam-to-dowel spacing, “b”, measured 60 mm (Fig 5). Holes for all connectors had the same geometry as in the first study.

The diameters of 24 randomly selected dowels and holes were measured with a digital caliper and maximum and the minimum diameters averaged. Differences between holes and dowel diameters averaged 0.1 mm.

#### METHOD OF TESTING

All joints were loaded as shown in Fig 6 in a universal testing machine. A loading rate of 8 mm/min was used for all specimens. Maximum load values were converted to bending moments by means of the expression  $M_{\max} = 0.0792 R$ , in which 0.0792 is the moment arm length (m) and R is the applied force (N). Joint strength was characterized as ultimate bending moment capacity.

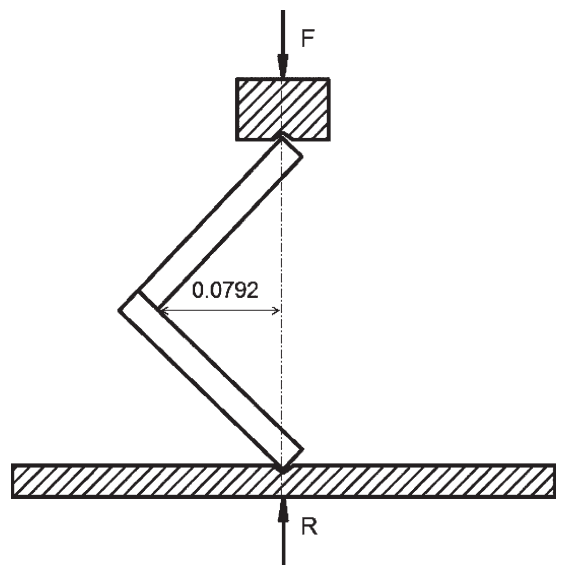

Figure 6. Loading of specimens in compression test with a measurement of bending arm in meters.

Before testing, all specimens were conditioned at 22°C and 35% RH for at least 48 h. Analyses of variance (ANOVAs,  $\alpha = 0.05$ ) were carried out to determine the significance of the differences between results for joint variations. Means were compared by using the Tukey test to identify which groups were significantly different.

Table 2. Average bending moment resistance of joints in the first study including Tukey results and coefficients of variation (COV).

Joint type	Edge distance	n	M <sub>max</sub> (N·m)	Tukey group	COV (%)
Cam	30 mm	18	8.11	a	19.63
Cam	60 mm	18	9.91	b	16.75
Cam	90 mm	18	7.89	a	15.53

RESULTS AND DISCUSSION

Average physical and mechanical properties of the laminated particleboard are shown in Table 1. As expected, the MOE and MOR of the material were high in comparison with non-finished particleboard (FPL 1999).

Results of the first set of bending tests are given in Table 2 and are shown graphically in Fig 7. All material failures occurred in the face members at the point of entry of the threaded portion of the cam fasteners (Figs 8 and 9). The splits extended to the end surface of the face members in those specimens having cams located 30 mm from the end of the member (Fig 9).

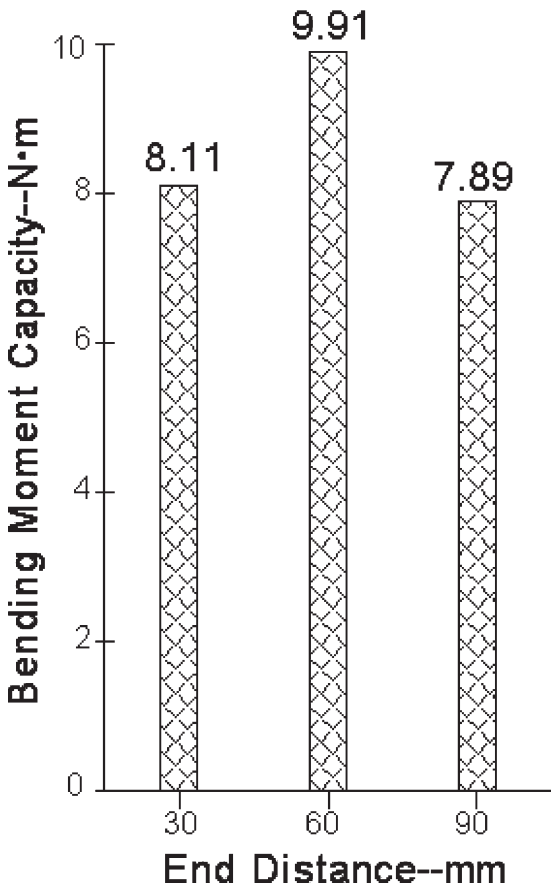

Figure 7. Effect of end distance on bending moment capacity of two-cam joints.

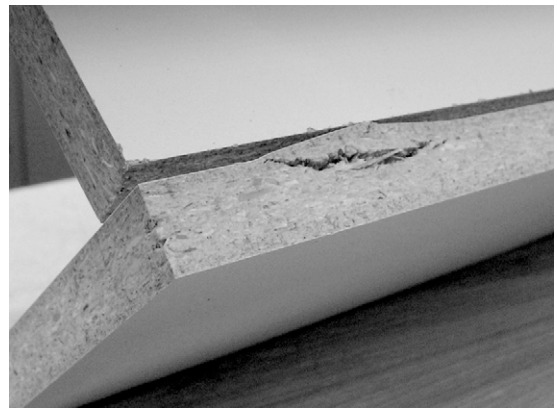

Figure 8. Typical mode of failure in the face member.

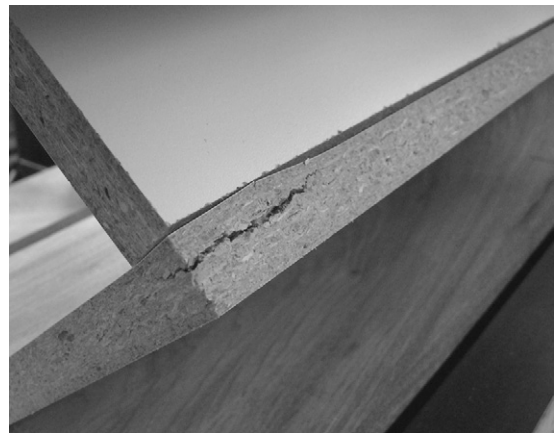

Figure 9. Typical mode of failure where splits extended to the end surface of the face member (for 30-mm cam distance from the edge of the member).

The results tend to indicate a zone of influence of 30 – 60 mm for the threaded portions of the cam connectors. Presumably, therefore, end splits can be prevented by locating these connectors at least 60 mm from the end of a member; however, the effect of internal bond on “zone of influence” and minimum end distance remains to be determined.

Results of the second set of tests are given in Table 3 and are shown graphically in Fig 10. Mode of failure of the joints was identical to that in the first study. The ANOVA of the maximum bending moments showed that there were significant moment capacity differences between joint variations at the 0.05 level. The Tukey procedure (Table 3) showed that cam-based joints with 1 or 2 dowels (or 2 nonglued dowels with unequal span) had the same significance level, ie they

Table 3. *Second study average bending moment resistance, Tukey results, and coefficients of variation (COV).*

Joint specimen	n	M <sub>max</sub>	Tukey	COV
(dowels)		(N·m)	group	(%)
1	12	10.61	b	18.12
2	12	12.28	b	9.16
2 (unequal span)	12	12.46	b	11.08
3	12	16.23	c	12.94
4	12	18.34	d	6.69
5	12	24.05	e	7.61

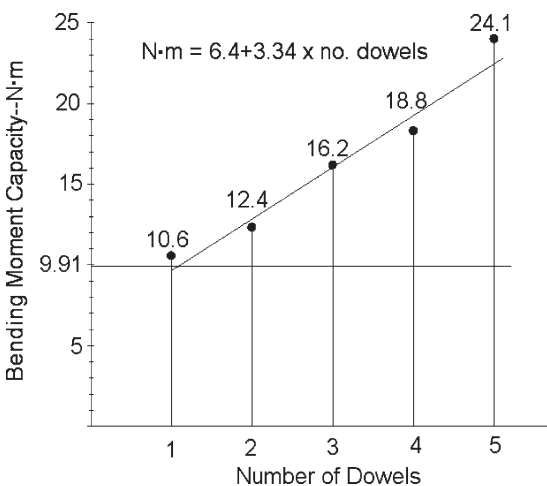

Figure 10. Bending moment capacities of joints constructed with 2 cams and 1, 2, 3, 4, or 5 dowels. The values given for two dowel in Table 3 have been averaged.

reached about the same bending moment capacity. Furthermore, the joints with two cam connectors (60-mm end distance) had the same significance level (same mean group) as when one nonglued dowel was added. The joint specimens with 2 cam connectors and 3, 4, or 5 nonglued dowels were each ranked by Tukey tests into separate significance groups as shown in Table 3. The results indicated that for a joint length of 760 mm, dowels significantly support the cam connectors. Presumably, when two or more dowels are added, stresses arising as the joint is loaded in compression are distributed more evenly over the joint length. Some RTA furniture producers use unequal dowel spacing, but uniform vs nonuniform spacing of the dowels was found to not have a significant effect on moment capacity of the joints. Finally, both studies showed that maximum bending moment capacity when a joint is loaded in compression most likely depends on the internal bond of the particleboard.

## CONCLUSION

In general, the end distance of the cam fasteners and the number of dowels included have a significant effect on the bending moment capacity of corner joints loaded in compression. In particular, the tests showed that: 1) cam connectors located 60 mm from the edge of the joint had the highest moment capacity of the three end distances tested; 2) one unglued dowel adds little to the bending moment capacity of a joint; 3) two equally or two unequally spaced unglued dowels add essentially the same bending moment capacity to a joint; and 4) two cam fasteners plus 2, 3, 4, or 5 unglued dowels increased bending moment capacity proportionately as the number of unglued dowels increased.

## ACKNOWLEDGMENTS

This research was supported by Fulbright-Masaryk Grant ME 659 and Research plan MSM 6215648902. Many thanks to Daniel Warner and Dr. Rado Gazo from Wood Research Laboratory, Purdue University.

## REFERENCES

- Albin R, Muller M, Scholze H (1987) Investigations on the strength of corner joints in case-type furniture. *Holz Roh Werkst* 45:171 – 178.
- ASTM (2002) D1037. Standard test methods for evaluating properties of wood-base fiber and particle panel materials. American Society for Testing and Materials, West Conshohocken, PA.
- Bachmann G, Hassler W (1975) The strengths of various furniture constructions, their components, and fasteners. Part I. (Die Festigkeit von Verschiedenen Möbelkonstruktionen, ihren Elementen und Verbindungsmitteln. Teil 1.). *Holztechnologie* 6(4):210 – 221.
- FPL (1999) Wood handbook—Wood as an engineering material. Gen Tech Rep FPL—GTR-113. USDA For Serv Forest Products Laboratory, Madison, WI. 463 pp.
- Ho Ch, Eckelman CA (1994) The use of performance tests in evaluating joint and fastener strength in case furniture. *Forest Prod J* 44(9):47 – 53.
- Joscak P, Cernok A (2002) Unosnost demontovatelných nabytkových spojov z DTD (Load capacity of RTA furniture joints made from particleboard). Page 15 *in Proc* Nabytok 2002, Oct 24 – 25, 2002, Technical University of Zvolen, Slovakia, ISBN 80-228-1193-9.
- Liu W, Eckelman CA (1998) Effect of number of fasteners on the strength of corner joints for cases. *Forest Prod J* 48 (1):93 – 95.
- Rajak ZI (1989) Efficient use of screws in the construction of corner joints for case goods. MS thesis, Purdue University, IN. 124 pp.
- Rajak ZI, Eckelman CA (1996) Analysis of corner joints constructed with large screws. *J Trop Forest Prod* 2(1): 80 – 92.
- Smardzewski J, Prekrad S (2002) Stress distribution in disconnected furniture joints. *Electronic Journal of Polish Agricultural Universities, Series Wood Technology, Volume 5/2002, Issue 2, ISSN 1505-0297.*
- Tankut N (2006) Moment resistance of corner joints connected with different RTA fasteners in cabinet construction. *Forest Prod J* 56(4):35 – 40.
- Zhang J, Eckelman CA (1993a) The bending moment resistance of single-dowel corner joints in case construction. *Forest Prod J* 43(6):19 – 24.
- Zhang J, Eckelman CA (1993b) Rational design of multi-dowel corner joints in case construction. *Forest Prod J* 43 (11/12):52 – 58.