

FRACTURE TOUGHNESS AND DURATION OF LOAD FACTOR II. DURATION FACTOR FOR CRACKS PROPAGATING PERPENDICULAR-TO-GRAIN

Arno P. Schniewind

Professor of Forestry, Forest Products Laboratory,
University of California, Richmond, CA 94804

(Received 7 April 1977)

ABSTRACT

Dead load tests of notched beams of Douglas-fir with the crack plane parallel-to-grain and the propagation direction of the crack perpendicular-to-grain showed that presently used duration of load factors can be used for this type of loading. A decrease in strength with increasing duration was observed, but the effect was less than in unnotched beams. Ramp loading tests of messmate stringybark and Douglas-fir notched beams showed increased loads at crack initiation at slower load rates. In messmate stringybark this increase was not statistically significant, but was found significant in Douglas-fir. These results suggest that stress redistribution is taking place around the notch tip, and that a duration of load factor need not be applied to this particular system.

Keywords: *Pseudotsuga menziesii*, *Eucalyptus obliqua*, fracture mechanics, duration of load, fracture toughness, beams, notched beams, bending, tension, acoustic emissions.

INTRODUCTION

A previous paper (Schniewind and Centeno 1973) described results of long-term loading tests of notched beams that had been done with the objective of determining the time to failure as a function of load level. The tests were made in the TL system, one of six principal systems for opening mode crack loading, where the first of the two indices (here T) refers to the outward normal to the crack plane and the second one (L) to the direction of crack propagation (Fig. 1). It was found (Schniewind and Centeno 1973) in static tests that, on the basis of fracture toughness values, two groups can be distinguished. The first contains the RT, TR, RL, and TL systems, and the second the LR and LT systems, with fracture toughness values of the second group roughly one order of magnitude higher than those of the first. On the basis of anatomy, three groups might be distinguished. These would combine the RT and TR systems as having crack planes parallel-to-grain with cracks propagating perpendicular-to-grain, the RL and TL systems as having crack planes parallel-to-grain with cracks propagating

parallel-to-grain, and finally, the LR and LT systems where both crack plane and propagation direction are perpendicular-to-grain. The previous paper having reported on long-term loading tests on a system from one of these three groups, the objective of the present paper is to report on investigations on the long-term loading characteristics of one system each from the other two groups. This is done on the assumption that within the groups the results would be similar.

RESULTS AND DISCUSSION¹

Long-term load tests in the TR system

The TR system is one of two systems where the crack plane is parallel-to-grain and the crack propagates perpendicular-to-grain. The crack plane in the TR system is the same as in the TL system that was previously investigated (Schniewind and Centeno 1973) for its duration of loading characteristics; only the direction of crack propagation differs. Since the two systems

¹ Since a variety of tests were made, the results are presented and discussed first and experimental details are given in the following section.

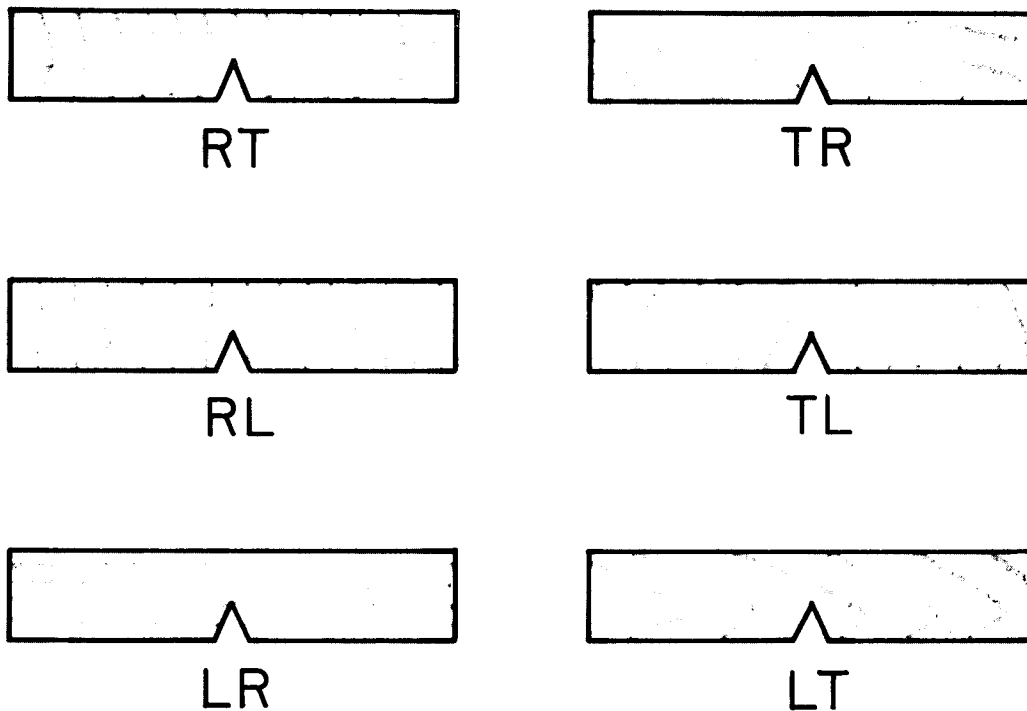

FIG. 1. Schematic representation of the six principal crack systems.

had similar fracture toughness values in static tests, it was expected that the behavior under long-term loads might also be similar. Therefore, only limited tests were planned to test this hypothesis.

Results of tests on single edge-notch (SEN) beams of air-dry Douglas-fir loaded at 85% of the estimated load level to cause failure in static tests are shown in Fig. 2. Tests were discontinued at slightly more than 50,000 min with the intention of using the method of censored distribution. Three of the 19 specimens tested survived that period and were discontinued without fracture. Unfortunately, two specimens failed during loading before a time to failure could be obtained. This resulted, in effect, in a doubly truncated distribution for which methods of analysis are not so readily available. Accordingly it was assumed that the time to failure of the specimens that failed during loading was 0.01 min. Based on this assumption the mean and standard deviations were estimated by the method of censored distribution (Hald 1952) and the

values so obtained were used to plot the straight line in Fig. 2, representing the model (normal) distribution.

The same kinds of test were repeated at a load level of 70%. It was intended to truncate this distribution at 70,000 min and the actual truncation point became 71,600 min. This turned out to be a somewhat unfortunate choice because only 7 of 19 specimens failed within that time span. The results are shown in Fig. 3. The line shown in the figure had to be fitted free-hand to the points since the degree of truncation was too large for use of the procedure given by Hald (1952). The mean value obtained by extrapolation to 50% probability of survival is 600,000 min, or approximately one order of magnitude greater than the value calculated from Pearson's (1972) equation at the same load level for unnotched beams.

Mean times to failure as a function of load level are shown in Fig. 4 for the present tests in the TR system, along with previously obtained data for the TL system

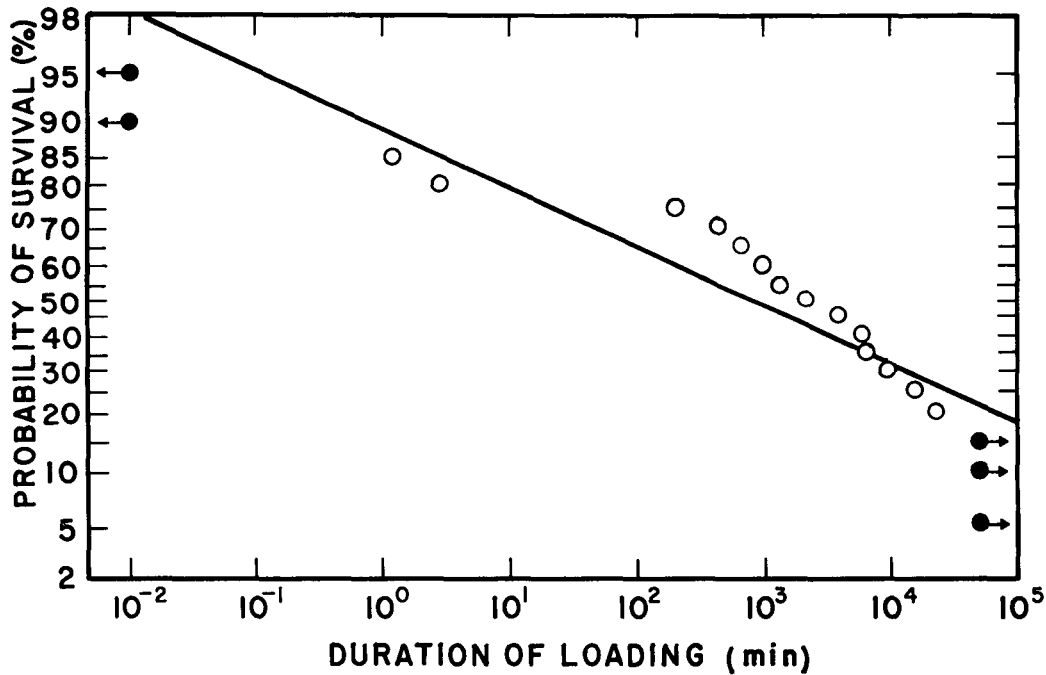

FIG. 2. Survival probability of Douglas-fir as a function of load duration at 85% load level in the TR system.

and Pearson's equation. Extrapolation of the line passing through the two data points in the TR system to 100% load level yields a time to failure of 1.2 min. This is a reasonable result since the static tests were

made so that failure could be produced in 1 to 2 min.

At load levels below 90%, the TR line is conservative in an engineering sense if compared to Pearson's line as representing the standard. Although the TR line is based on limited data, there is little doubt that it is conservative with respect to the TL line. Since in practical terms a separate treatment does not seem warranted, further investigation of the TR system appeared to be unnecessary.

In 5 of the 12 specimens that did not fail, a small amount of slow crack growth ranging from 1/32 to 1/8 inch was noted just before unloading. All of these ended in springwood, just as the ends of discontinuous cracks observed by Schniewind and Pozniak (1971) were invariably within the springwood. Possibly the larger size of the earlywood tracheids and their lumina provides a mechanism for crack arrest, which would not apply if the same crack propagates parallel to the tracheids, as in the TL system. The capability to undergo some

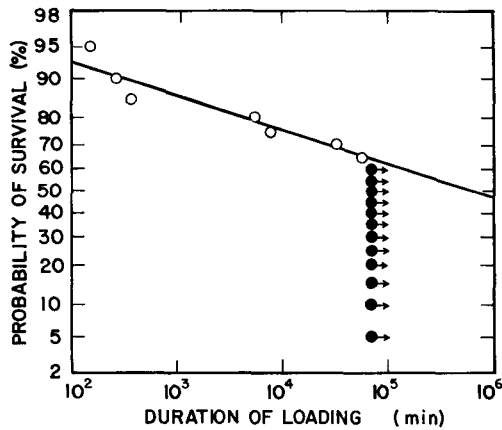

FIG. 3. Survival probability of Douglas-fir as a function of load duration at 70% load level in the TR system.

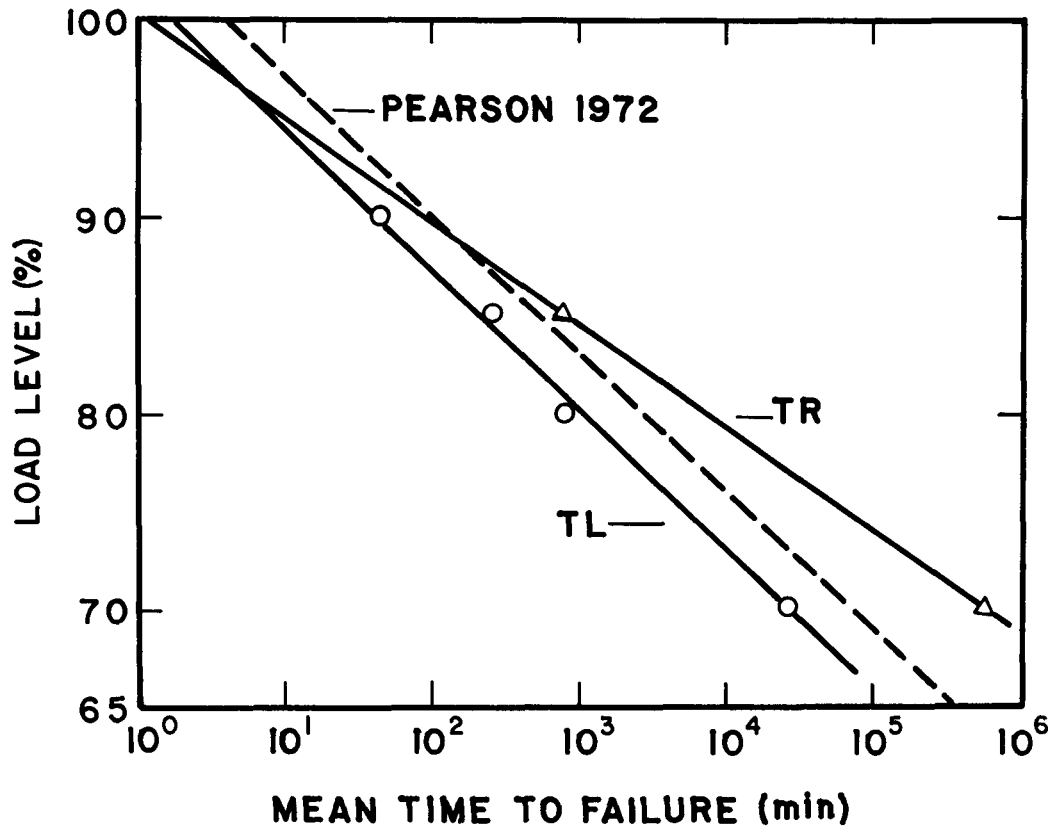

FIG. 4. Mean time to failure as a function of load level for unnotched beams (Pearson 1972), notched beams in the TL system (Schniewind and Centeno 1973), and notched Douglas-fir beams in the TR system (present study).

slow crack growth followed by crack arrest in a "tougher" spot might then explain why the duration of load factor is less severe for the TR as compared to the TL system.

Long-term load tests in the LT system

The LT and LR systems are probably the most important since they apply to such elements as beams and tension members with notches and other discontinuities. In these systems experimentation becomes very difficult because the crack does not propagate in the usual sense. Instead it is arrested almost immediately and then diverges 90 degrees into one or two splits along the grain starting at the root of the notch or crack tip. Using SEN tension or bending specimens, the onset of cracking is not accompanied by a maximum load,

but can be detected by determining the proportional limit in a plot of crack-opening displacement (COD) versus load (Leicester and Bunker 1969; Schniewind and Centeno 1973). For long-term load tests at constant load, such an approach is not possible. Therefore, initial efforts were directed toward means of detecting crack initiation.

Early attempts at such testing were made in Australia² using messmate stringybark (*Eucalyptus obliqua*). Thin lines of conductive silver paint were placed on SEN tension specimens so that parallel-to-grain splits originating at the crack tip would

²The author is indebted to CSIRO, Australia, for the opportunity to make these experiments at the former Forest Products Laboratory, South Melbourne, Victoria, in 1969/70.

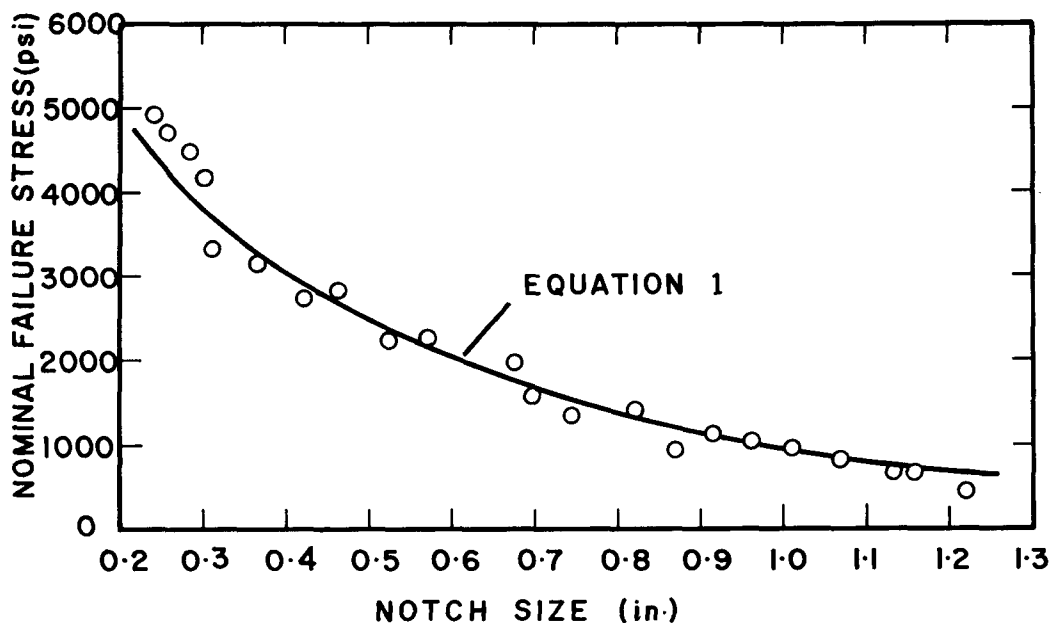

FIG. 5. Nominal failure stress in tension of messmate stringybark as a function of notch size in the LR system.

interrupt an electrical circuit and thus indicate crack initiation. It was soon found that the silver paint was somewhat ductile and that relatively large displacements were required before the circuit was interrupted. A group of 22 SEN tension specimens in the LR system with varying notch sizes was tested statically. Using the electrical indication, the average fracture toughness value, K_{Ic} , was 5600 psi $\sqrt{\text{inch}}$. Based on proportional limit in the COD versus load plot, the value was 4690 psi $\sqrt{\text{inch}}$, illustrating the late indication obtained with the silver paint. Figure 5 shows a plot of nominal failure stress (stress at crack initiation based on the unnotched section) as a function of notch size. The curve in Fig. 5 was obtained by calculating the critical stress intensity factor of each specimen according to Eq. 1, based on the proportional limit of the COD vs. load plot, and then using the average of all values to calculate points for the curve. Thus, the vertical position of the curve is determined by the data, but the shape conforms to theory. As may be seen the fit of the data is very good,

indicating that Eq. 1 gives the proper relationship between strength and notch size.

$$K_I = \frac{Pa^{\frac{1}{2}}}{BW} Y, \quad (1)$$

where K_I = stress intensity factor, P = load, a = notch or crack size, B = specimen thickness, W = specimen width, and Y is given by [Brown and Srawley 1966]:

$$Y = 1.99 - 0.41(a/w) + 18.70(a/w)^2 - 38.48(a/w)^3 + 53.85(a/w)^4.$$

Somewhat better results were obtained using a conductive paint containing carbon rather than silver. This type of paint is normally used in constructing special resistors. It was possible to make lines with sufficient resistance to be readily measurable, and to monitor changes in resistance during loading of the specimen. On a set of 19 SEN tensile specimens of messmate stringybark with a notch size of 0.9 inch (specimen width 2 inches), the results shown in Table 1 were obtained. It may be seen that there is generally good agreement between load at crack initiation as

TABLE 1. Load at crack initiation of SEN tensile specimens of messmate stringybark

| No. | Load Determination in Pounds | | |
|-------|------------------------------|------------------|---|
| | Visual | COD vs load plot | 6% change in resistance of conductive paint |
| 1 | 679 | 689 | 571 |
| 2 | 603 | 794 | 784 |
| 3 | 571 | 550 | 552 |
| 4 | 397 | 408 | 421 |
| 5 | 570 | 620 | 609 |
| 6 | 428 | 586 | 600 |
| 7 | 357 | 614 | 659 |
| 8 | 684 | 684 | 680 |
| 9 | 243 | 559 | 562 |
| 10 | 620 | 667 | 670 |
| 11 | 400 | 634 | 604 |
| 12 | 551 | 490 | 486 |
| 13 | 579 | 560 | 579 |
| 14 | 445 | 484 | 436 |
| 15 | 343 | 576 | 550 |
| 16 | 915 | 613 | 595 |
| 17 | 606 | 540 | 566 |
| 18 | 693 | 623 | 630 |
| 19 | 622 | 600 | 584 |
| Mean: | 542 | 594 | 586 |

determined from the COD versus load plot and the load at a 6% change in resistance of the conductive paint line. Visual determinations were much more erratic and, surprisingly, gave a lower average load at crack initiation. The mean critical stress intensity factor, based on loads at 6% change in resistance was $4900 \text{ psi } \sqrt{\text{in.}}$.

A similar set of 50 SEN tensile specimens of messmate stringybark, notch size 0.9 inch, was tested at various testing speeds to produce times to failure ranging from 0.01 to 100 min. Crack initiation was determined on the basis of a 6% change in resistance of conductive paint lines around the crack tip. The results are shown in Fig. 6. There is considerable scatter of the critical stress intensity factor values, but there is no evidence of a decrease in values with increasing time to failure. Instead, the regression line of K_{Ic} on $\log(t)$ has a positive slope. Statistical analysis showed that regression was not significant at the 5% level. Thus, it is not possible to conclude that there is an increase in strength with time of loading in the LR system, but the absence of a de-

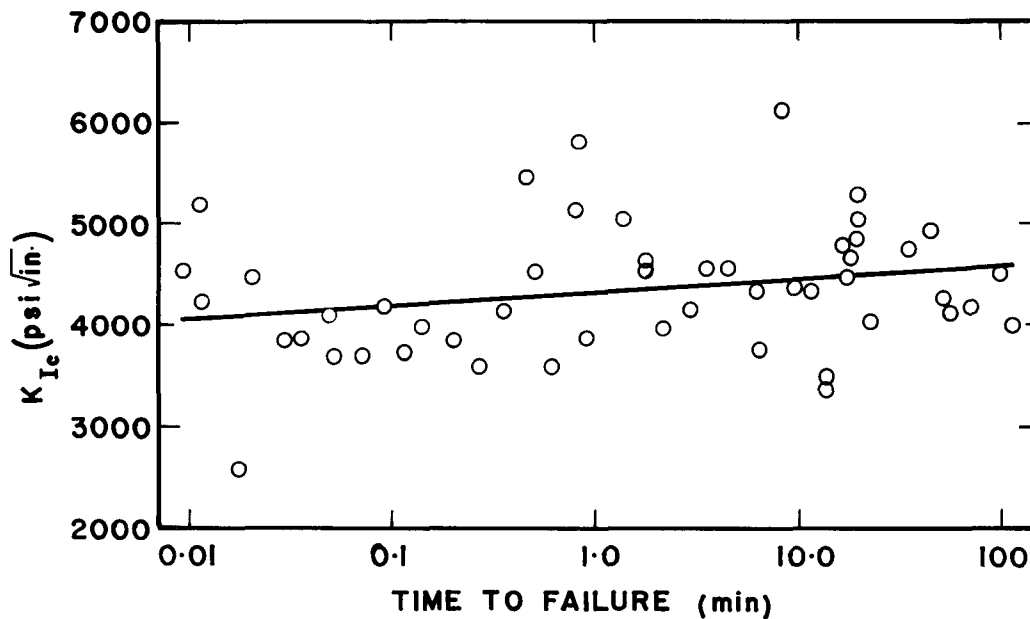

FIG. 6. Critical stress intensity factor of messmate stringybark as a function of time to failure in ramp loading in the LR system.

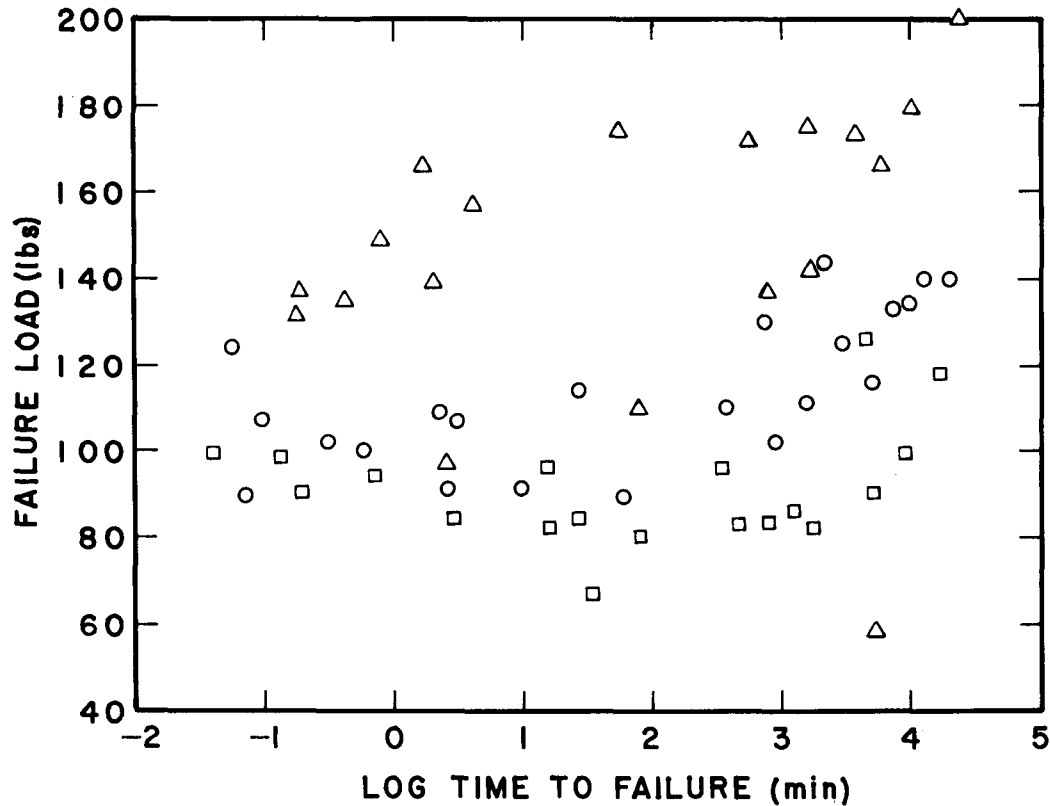

FIG. 7. Failure load of Douglas-fir notched beams as a function of time to failure in ramp loading in the LT system. Squares, circles, and triangles identify the three planks from which the specimens were taken.

crease alone, especially considering that the experiments covered more than four decades of log time, is in itself highly significant. It suggested a possible redistribution of stresses around the crack tip which is time-dependent.

Some long-term load experiments were attempted with messmate stringybark using SEN tension specimens and dead loading. Problems arose that were at first attributed to inadequate performance of the conductive paint lines (carbon based) used for detecting crack initiation. However, there was some evidence that failure occurred either immediately after loading or not for a long time, if at all, no matter what the load level.

Following the author's return from Australia, work was continued with Douglas-fir

(*Pseudotsuga menziesii*). The use of acoustic emission measurements for detecting crack initiation appeared very promising in preliminary static experiments. In dead load tests, however, failure occurred either immediately or not for a long time, even at load levels as high as 95% of the load to cause crack initiation in static tests. Load levels beyond 100% could be achieved without causing immediate failure, provided they were preceded by a period of loading at levels close to but less than 100%. This suggested further that stress redistribution was taking place. It also suggested that in the LT system, dead loading supplies insufficient stored energy to cause the diverted crack to propagate far enough so that this can be clearly registered. Ramp loading, on the other hand, continually sup-

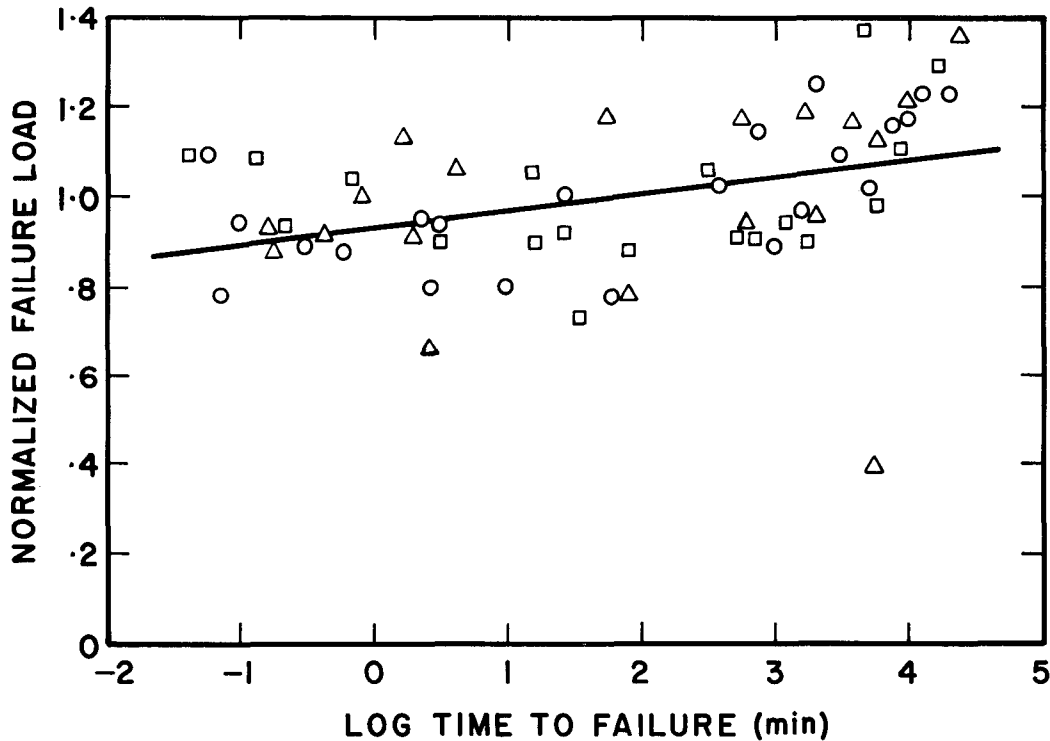

FIG. 8. Normalized failure loads (normalized with respect to plank average) of Douglas-fir notched beams as a function of time to failure in ramp loading in the LT system. Squares, circles, and triangles identify the three planks from which the specimens were taken.

plies additional energy and thus appeared to be more suited to investigation of the LT system. Consequently, it was decided to make ramp loading tests over an extended period.

The results of ramp loading tests covering six decades on a log time scale with material from three Douglas-fir planks are shown in Fig. 7. There are clearly substantial differences in the properties of the three planks, and this contributes significantly to the overall variation of the data. However, it is evident that there is no substantial decrease of the load causing crack initiation as the time to failure increases. Figure 8 presents the same data without the effect attributed to differences in planks. Load at crack initiation was normalized with respect to the average from all data points for each plank. Now a definite trend of increased load at crack initiation can be noted as the time to failure increases. One point shows

a very low load at approximately 5,400 min to failure; possibly the specimen was initially defective, although no evidence to that effect could be found. In spite of seeming rather out of line, the point was included in the statistical analysis.

A linear regression analysis was made of the data in Fig. 8, with normalized failure load as the dependent and time to failure as the independent variables. The slope of the regression line is positive and is significant at the 1% level. Somewhat better fits could be obtained by using second degree polynomials, with and especially without the linear term, but this is of relatively minor importance. What is important is that in this form of loading, the normally experienced decrease in strength with increasing time to failure does not apply. In fact, the data suggest an increase in strength at longer loading times.

Leicester (1974), in somewhat similar ex-

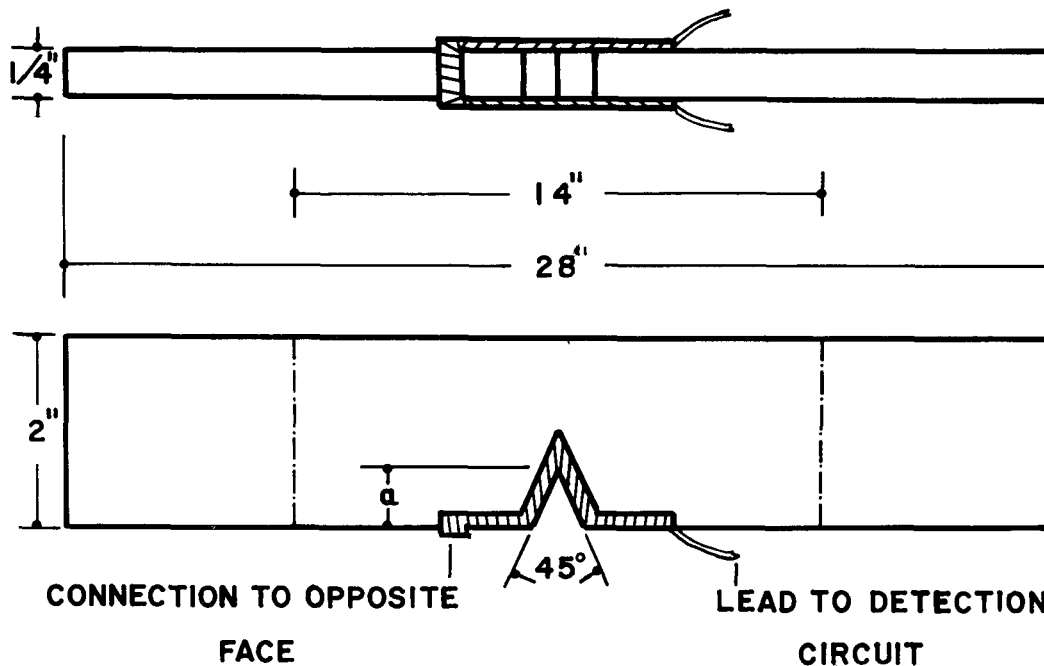

FIG. 9. SEN tension specimen used for messmate stringybark tests. Two by seven inch areas at the ends were used for gripping. The drawing is not to scale.

periments, also obtained results that differed qualitatively from the Madison curve. However, in a range of failure times from 1 min to 3 h, he obtained a maximum at about 20 min. No such trend is evident in the present data, which encompass a much larger time scale.

These results are of particular interest when examined in light of the findings of Madsen (1973, 1975) that lumber, in contrast to small clear specimens of wood, does not follow the relationship between load level and duration of load which forms the basis for current practice in timber structural design. Instead, he found that the weakest 5% of the material, when subjected to bending, exhibited virtually no duration of load effect. Although no major effort was made to discover the underlying causes for this observation, there was some suggestion that, in low strength lumber, stress concentrations in the vicinity of knots and other defects are the major factors determining strength. Under long-term loading, it would be possible to obtain a redistribu-

tion of stresses that could then offset, to a greater or lesser extent, the static fatigue which the bulk of the material would be subjected to (Madsen 1975; Madsen and Barrett 1976). Since sharp notches such as those used in this study represent an extreme form of stress concentration, the results of this study show that a modification of the load duration factor is possible when stress concentrations exist. It should also be noted in this connection that Pearson (1974) demonstrated that there was a close relation between the effect of notches and of knots on tensile strength parallel-to-grain, so much so that he proposed simulating knots by the introduction of notches in tensile strength investigations.

EXPERIMENTAL

Material for long-term load tests in the TR system was taken from the same six cants of Douglas-fir used by Schniewind and Centeno (1973) for making static tests. Their data were in fact used to establish

the estimated 100% load levels for the specimens tested in this study. SEN beam specimens were 5 inches long, $\frac{1}{2}$ inch wide, and 1 inch deep. The tension side was notched at midlength with a notch 0.45 inch deep and a notch angle of 45° (Fig. 2 of Schniewind and Centeno 1973). The specimens were center loaded over a 4-inch span in a loading frame with dead loads applied through a lever system. All material was conditioned to 12% nominal moisture content before test, and the tests were carried out in a humidity chamber controlled at 12% equilibrium moisture content conditions. Time to failure was determined with time meters to 0.1 min. Loading was done by hand in a matter of seconds, and timing was started as soon as full load was applied.

A number of planks of messmate stringybark were cut into tensile specimen blanks; material for particular tests was selected from this set of blanks at random. The SEN tension specimen that was used for LR system tests is shown in Fig. 9. Notch depth was 0.9 inch except for one series of tests which included notch depth as a variable. Also shown in Fig. 9 is the placement of conductive paint lines when they were used. The tests were made on an Instron testing machine. Except when time to failure was a variable, tests were made to produce failure in about 3 min. The set of specimens with varying notch sizes was tested by connecting the silver paint line on the specimen to the modified pip switch of the testing machine. This caused a pip on the diagram recording load versus head movement at the moment the paint line was severed. COD was monitored with an extensometer placed across the notch and recorded as a function of load on a separate X-Y recorder. The set of tests made to compare means of detecting crack initiation was made by recording both COD and conductive paint line resistance as a function of load. During tests made at varying testing speeds, only paint line resistance was recorded as a function of load. All of the messmate stringybark material was conditioned at 12% nominal moisture content before test. Actual moisture content as deter-

mined from representative samples was 10.8%.

Tests of Douglas-fir in the LT system were made with the same type of specimen as in the TR system long-term load tests, except that the grain orientation was, of course, different. The ramp loading tests were made on a table model Instron testing machine for failure times up to 100 min. The slowest speeds available on the machine led to failure within 5 min. Tests with times to failure between 5 and 100 min were achieved by stop/start operation of the loading mechanism, adding from two to three pounds of load at regular time intervals. Loading regimes varied from 3 lbs every 20 s to 2 lbs every 2 min. The load function thus resembled a step function with slanting risers. Each load function had at least 28 such steps, so that a close approximation to true ramp loading was achieved. For failure times greater than 100 min, a specially constructed ramp loader was used. This consisted of a loading frame with a rubber bellows, air-pressure actuator for applying the load. The load was sensed with a strain gage load cell. The output of the load cell was compared with the output of an adjustable ramp generator, which was set for each experiment to the desired ramp function. The difference, or error voltage, was used to drive a pressure regulator connected to the load actuator. During the test an acoustic emission transducer was attached to each specimen. Dunegan/Endevco Series 3000 acoustic emission instrumentation, including an S140B transducer was used. Gain was set at 65 db total and a filter setting of 0.1 to 0.3 MHz was used. Load and total counts were both recorded as a function of time. The failure criterion was 50 counts of acoustic emission at the settings described. All specimens were conditioned to a nominal moisture content of 12% before testing. Ramp loading tests lasting less than 100 min were made in the open laboratory, but those lasting longer were carried out in a humidity chamber controlled at 12% equilibrium moisture content conditions.

CONCLUSIONS

Tests showed that in the TR system, a load duration factor is in effect, but it is not as severe as in the TL system. Assuming that TR and TL systems are representative of the RT and RL systems, respectively, this means that presently used adjustments for duration of loading can be applied to opening mode crack loading in the TL, TR, RT, and RL systems.

On the other hand, in the LT and LR systems a different situation exists. Based on a composite of tests and observations, there is evidence that a redistribution of stresses takes place in the vicinity of the crack tip. This presumed redistribution of stresses acts to counteract the normal duration of load effect, and there is even an indication that there may be an increase rather than a decrease in failure loads as the time to failure is increased. This would mean that in practical situations, no adjustment for duration of load is required if failure is determined in terms of fracture mechanics and loading is in the opening mode in the LT and LR systems.

REFERENCES

- BROWN, W. F. J., AND J. E. SRAWLEY. 1966. Plane strain crack toughness testing of high-strength metallic materials. Spec. Tech. Publ. No. 410, Am. Soc. Test. Mat., Philadelphia.
- HALD, A. 1952. Statistical theory with engineering applications. John Wiley & Sons, New York.
- LEICESTER, R. H. 1974. Fracture strength of wood. First Australian Conf. on Engineering Mat., The University of New South Wales, Sidney, Australia.
- , AND P. C. BUNKER. 1969. Fracture at butt joints in laminated pine. *For. Prod. J.* 19(2):59-60.
- MADSEN, B. 1973. Duration of load tests for dry lumber in bending. *For. Prod. J.* 23(2):21-28.
- . 1975. Duration of load test for wet lumber in bending. *For. Prod. J.* 25(5):33-40.
- , AND J. D. BARRETT. 1976. Time-strength relationship for lumber. Dep. Civil Eng., Univ. British Columbia, Struct. Res. Ser. Rep. No. 13, Vancouver, British Columbia.
- PEARSON, R. G. 1972. The effect of duration of load on the bending strength of wood. *Holz-forschung* 26(4):153-158.
- . 1974. Application of fracture mechanics to the study of the tensile strength of structural lumber. *Holzforschung* 28(1):11-19.
- SCHNIEWIND, A. P., AND J. C. CENTENO. 1973. Fracture toughness and duration of load factor. I. Six principal systems of crack propagation and the duration factor for cracks propagating parallel to grain. *Wood Fiber* 5(2):152-159.
- , AND R. A. POZNIAK. 1971. On the fracture toughness of Douglas-fir wood. *Eng. Fract. Mech.* 2(3):223-233.