

COMPARISON OF NONDESTRUCTIVE TESTING METHODS FOR EVALUATING NO. 2 SOUTHERN PINE LUMBER: PART A, MODULUS OF ELASTICITY

*B. Z. Yang**†

PhD Candidate
E-mail: zhuooyang@gmail.com

R. D. Seale†

Thompson Professor
E-mail: rds9@msstate.edu

R. Shmulsky†

Professor
Department of Sustainable Bioproducts
Mississippi State University
Mississippi State, MS 39762-9820
E-mail: rs26@msstate.edu

J. Dahlen†

Assistant Professor
Warnell School of Forestry and Natural Resources
University of Georgia
Athens, GA 30602-2152
E-mail: jdahlen@uga.edu

X. Wang†

Research Forest Products Technologist
USDA Forest Service, Forest Products Laboratory
Madison, WI 53726-2398
Email: xwang@fs.fed.us

(Received February 2015)

Abstract. Modulus of elasticity (MOE, or E) is one of the main quality indicators in structural lumber stress grading systems. Due to a relatively high amount of variability in contemporary sawn lumber, it is important that nondestructive evaluation technology be utilized to better discern high-E-value pieces from low-E-value pieces. The research described in this study is from a laboratory test of three nondestructive technologies applied to 343 pieces of visually graded No. 2 southern pine lumber collected across the southeast region of the United States. The evaluated technologies included continuous lumber test in continuous proof bending (Metriguard Model 7200 High Capacity Lumber Tester), transverse vibration (Metriguard E-Computer), and two stress wave tools (Falcon A-Grader and Carter Holt Harvey Director HM200). For each of the nondestructive techniques, results were compared with static E as determined by the four-point static bending tests following ASTM D198-14. In all cases, the nondestructive techniques successfully predicted E for all lumber sizes, with linear regression r^2 values ranging from 0.77 to 0.86.

Keywords: Nondestructive evaluation, transverse vibration evaluation, longitudinal stress wave evaluation, high-capacity lumber tester, modulus of elasticity, machine-stress-rated lumber, machine-evaluated lumber.

* Corresponding author

† SWST member

INTRODUCTION

Modulus of elasticity (MOE, or E) describes the relationship of stress and strain of a material under a given force and is one of the main quality indicators in structural lumber stress grading systems. Accurate MOE values allow engineers and designers to make safe and economical utilization decisions for structure design. Currently, visual stress grading and machine grading are widely used methods in the lumber marketplace. Visual stress grading was first developed for structural lumber in the 1920s and permits the efficient production of structural materials compatible for the needs of the construction industry (Galligan and McDonald 2000). Due to the fact that visually graded design values are assigned by species and sizes, the wide variety of grade-species combinations results in a large number of allowable design stresses in the marketplace.

Nondestructive testing (NDT) methods for evaluating the design stress of lumber products were developed in the 1950s and applied commercially since the 1960s (Ross et al 1991). To assign a grade to a given lumber piece, the machine grading process conducts NDT on the lumber and then a visual check of the lumber is done because some machines cannot or may not properly evaluate defects such as knots (Galligan and McDonald 2000; Kretschmann and Green 2010a). The NDT allows for more uniform lumber within a particular grade compared with visual grading (Galligan and McDonald 2000). The success of applying NDT techniques dramatically improves the grading accuracy over visual stress grading methods; however, it requires additional up-front investment in machinery compared with visual grading (Halabe et al 1997).

Three NDT methods that have received attention during the past decades include continuous proof bending, transverse vibration, and longitudinal stress wave techniques. The continuous proof bending technique applies fundamental mechanics of materials theories to obtain MOE values via continuous static bending in flatwise orientation under a low deflection limitation. The transverse vibration techniques have been widely

accepted in the grading of wood products (Ross et al 1991; Ross and Pellerin 1994; Wang et al 2002), which can be explained by a rigorous examination of fundamental mechanics. The boundary conditions have been demonstrated to be influential when applying this method. The MOE value can be related and calculated with the oscillation frequency of a simply supported beam by the following equation (Ross and Pellerin 1994):

$$E_T = \frac{f^2 WS^3}{CIg} \quad (1)$$

where E_T is the transverse vibration MOE, f is the natural frequency of the first mode of transverse vibration of the beam, W is the weight of the beam being tested, S is the span of the beam between two supports, I is the moment of inertia of the beam in the vibrating direction, g is the acceleration caused by gravity, and C is a constant for a beam (12.65 for a beam freely supported at two nodal points and 2.46 for a beam simply supported at its ends).

The longitudinal stress wave techniques have also been proven accurate when evaluating the quality of wood products within various species. Transmission time of sound waves, or acoustic velocity, and attenuation of induced stress waves in a material are frequently used as NDT parameters. The dynamic MOE can then be calculated from the measured wave parameters, as shown in the following equation (Ross and Pellerin 1994):

$$E_d = \rho V^2 \quad (2)$$

where E_d is the axial dynamic modulus of elasticity; ρ is the density of the material; and V is the propagation speed.

Since NDT tools were introduced in North America, the volume of mechanically graded lumber has increased during the past few decades (Galligan and McDonald 2000; Kretschmann 2010b). At the same time, research has demonstrated that acoustic tools can be used to better sort logs before processing (Achim et al 2011). However, the industry have been slow in implementing NDT grading technologies and the

overwhelming majority of structural lumber in North America is still visually graded (U.S. Census Bureau 2012). During the period from the late 1980s to early 2010s, softwood design value performance changes had been noticed but the visual characteristics did not change appreciably. Thus, there is a current and pressing need of the lumber industry to continue to develop and adopt cost-effective NDT methods. Additional data regarding machine stress grading options may be beneficial with respect to promoting the application of machine stress grading to the lumber industry.

The objective of this study was to relate the NDT results to the actual MOE value of No. 2 visually graded southern pine (SP) lumber as determined in static bending, thus evaluating the accuracy and reliability of several NDT methods that are currently and widely used for grading and testing structural lumber. A value of MOE in edge-wise bending was assigned by different machine stress grading NDT methods. To obtain a further understanding of the expression of this MOE, experimental tests on full size, in-grade specimens were conducted with four commercially available stress grading tools.

MATERIALS

Visual grade No. 2 SP lumber was selected for this study as it accounts for the largest percentage of SP market share by grade (SFPA 2005). The lumber was sourced randomly from 31 different mills throughout the southeastern United States. A total of 490 pieces of lumber with a grade stamp was purchased in lots of 10 pieces per mill per size from mills located in Alabama (five mills), Arkansas (six mills), Florida (one mill), Georgia (four mills), Louisiana (five mills), Mississippi (five mills), North Carolina (one mill), South Carolina (two mills), and Texas (two mills). The selected lumber included boards of four different sizes, but each dimension was not purchased at each mill due to limited availability from the retail establishment of limitations in the range of produced sizes. The attempt of selecting 10 pieces per mill was chosen as it accounted for more between-mill variation and

Table 1. Dimensions of No. 2 SP lumber.

Group	Thickness (mm)	Width (mm)	Length (m)	Quantity	
				By length	Total
2 × 6	38	140	2.45	16	86
	—	—	3.06	44	—
	—	—	3.68	26	—
2 × 8	38	185	3.68	76	112
	—	—	4.29	8	—
	—	—	4.90	28	—
2 × 10	38	236	4.29	33	91
	—	—	4.90	58	—
2 × 12	38	287	4.29	25	54
	—	—	6.13	29	—

mimicked the in-grade testing procedure (Jones E. 1989). All of the lumber was transported to the testing laboratory at Mississippi State University, and then visually regraded by a certified SP lumber grader. Only the lumber which was confirmed as No. 2 was considered in this study. Further mechanical properties details on the lumber can be found in Dahlen et al (2014).

A total of 343 pieces of lumber specimens were divided into four groups according to the cross-section dimensions: 86 pieces of 2 × 6 (44 × 140 mm), 112 pieces of 2 × 8 (44 × 185 mm), 91 pieces of 2 × 10 (44 × 236 mm), and 54 pieces of 2 × 12 (44 × 287 mm). Length of the lumber specimens ranged from 2.45 to 6.13 m. Detailed information of lumber specimens is listed in Table 1. The average MC when tested was 11.4%, and the average air-dried density was 556.7 kg/m³. Not all pieces were available to be tested with all NDT tools, thus the sample sizes for each NDT method were different.

TEST METHODS

Specimens were evaluated nondestructively with continuous proof bending, transverse vibration, and longitudinal stress wave methods. The output from all NDT tools was adjusted by specimen dimensions.

Continuous Proof Bending Evaluation

A mobile High Capacity Lumber Tester Model 7200 (HCLT, Metriguard Inc., Pullman, WA) was set up at Mississippi State University (Fig 1). The



Figure 1. Continuous proof bending evaluation: mobile High Capacity Lumber Tester Model.

HCLT testing was performed in a continuous manner by subjecting each test specimen to a series of rollers deflecting each specimen. The deflection data were recorded to calculate the MOE values. A minimum flatwise MOE (E_{LCHLT}) and an average flatwise MOE (E_{HCLT}) from this testing tool were obtained and reported.

Transverse Vibration Evaluation

An E-computer Model 340 (Metriguard Inc.) was used as the transverse vibration testing tool. As

shown in Fig 2, the test was setup edgewise in a simply supported beam configuration. Member vibration was induced in the middle of the lumber by a hammer and the impact detected with an accelerometer fixed to a support. Member weight and dimensions (length, width, and thickness) were also recorded as input. The dynamic MOE (E_{TV}) values were obtained directly from this tool.

Longitudinal Stress Wave Evaluation

An A-Grader (Falcon Engineering Ltd., Inglewood, New Zealand) and Director HM200 (Carter Holt Harvey fiber-gen, Christchurch, New Zealand) were used as the stress wave testing tools. A mechanical stress wave was induced at one end of the specimen by a hammer impact and detected at the same end with an accelerometer (Fig 3a) or a microphone receiver (Fig 3b). Member weight and dimensions (length, width, and thickness) were recorded as an input for the Falcon. The devices recorded the velocity of the stress wave and the estimated dynamic MOE (E_{SW1}) value was obtained directly from Falcon. Stress wave velocity (V_{SW2}) was the output of Director

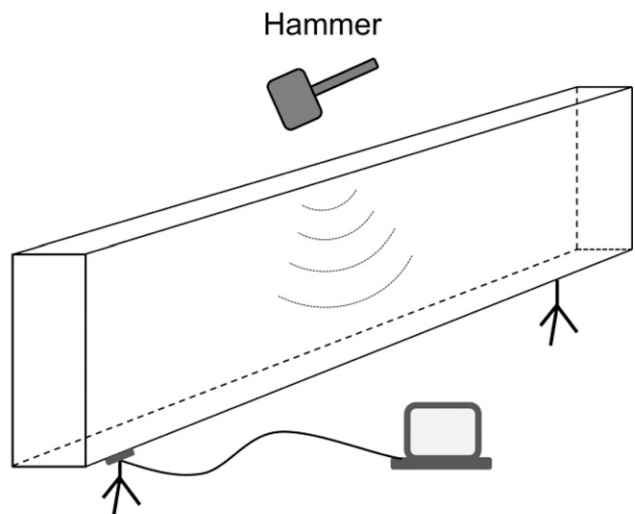
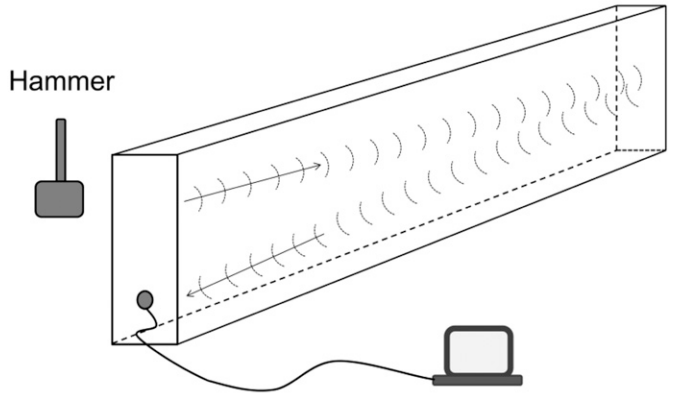
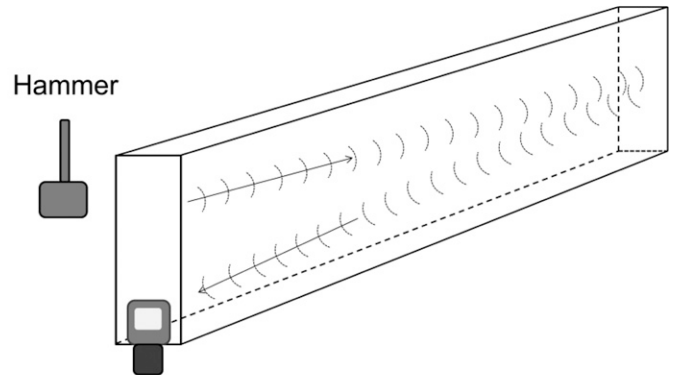

Figure 2. Transverse vibration evaluation: E-computer Model 340.



(a)



(b)

Figure 3. Longitudinal stress wave evaluation: (a) A-Grader; (b) Director HM200.

HM200, dynamic MOE (E_{SW2}) was then calculated based on the V_{SW2} and the density values.

Static Four-Point Bending Test

Following the NDT tests, the specimens were destructively evaluated by four-point static bending tests following ASTM D198-14 (ASTM 2014) to obtain the static bending MOE value (Fig 4). The

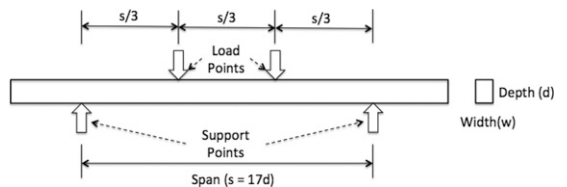

Figure 4. Static four-point bending test: ASTM D 198-14, test support spans were fixed with a span to depth ratio of 17 to 1.

test support spans were fixed with a span to depth ratio of 17 to 1 (2380-140 mm, 3145-185 mm, 4012-236 mm, 4879-287 mm). The test support spans were fixed in different cross section lumber specimens, herein, this fact excluded differences in the varying lengths within each group of lumber.

RESULTS AND DISCUSSION

Analysis of variance at the 5th level of significance ($\alpha = 0.05$) was performed to characterize the differences of mean static bending MOE (E_{SB}) among the types of specimens sampled. The differences among the groups were statistically significant (p value = 0.001) while the mean separation for the four groups of specimens were checked using Tukey's method. Statistical analysis of the MOE values and comparisons to the published value are listed in Table 2.

Linear Regressions

Linear regression analyses were conducted between E_{SB} and lowest NDT MOE values from continuous

proof bending machine (E_{LHCLT}), average NDT MOE values from continuous proof bending machine (E_{HCLT}), transverse vibration MOE (E_{TV}), and longitudinal stress wave MOE (E_{SW1} , E_{SW2}) were conducted using SAS 9.4 (SAS 2013). The regression models were designed in accordance with Eq (3). A regression model was also developed between E_{SB} and stress wave velocity (V_{SW2}). The previous research demonstrated a favorable coefficient of determination when correlating E_{SB} and V_{SW} (Ross and Pellerin 1994: $r^2 = 0.78$ for Douglas fir; Halabe et al 1997: $r^2 = 0.61$ for green SP, $r^2 = 0.45$ for dry SP). Therefore, in this study, linear regressions were conducted given the independent variables (x , which can be represented by E_{LHCLT} , E_{HCLT} , E_{TV} , E_{SW1} , V_{SW2} , and E_{SW2}) and the dependent variables (y , E_{SB}).

$$y = \beta_0 + \beta_1 x + \varepsilon \quad (3)$$

To compare the direct results from different NDT methods, linear regression models were first developed for the overall data with lumber size as a block variable using the SAS CLASS procedure (Table 3). Data were subsampled to include the pieces that were run in conjunction with the HCLT method, and the full samples that were run with the handheld tools. Coefficient of determination (r^2), which expresses the percentage of the total variability explained by the regression model, was the main focus in this study. Root-mean-square error (RMSE), which represents

Table 2. MOE values of tested No. 2 SP lumber.

Tukey grouping ^a	Size	N	Mean (%)	Median	StdDev	
A	—	2 × 6	86	10.7	10.5	2.4
A	—	2 × 8	112	10.6	10.6	2.6
A	B	2 × 10	91	11.5	11.4	2.8
—	B	2 × 12	54	12.1	12.2	2.1

^a Tukey's test was conducted with $\alpha = 0.05$.

Table 3. Linear regression relationship for NDT MOE and static bending MOE value.

y	x	β_0	β_1	r^2	RMSE	F value	Counts
E_{SB} ^a	E_{LHCLT} ^b	4.24	0.93	0.78	1.22	109.05	130
E_{SB}	E_{HCLT} ^c	2.04	0.93	0.85	1.00	175.40	129
E_{SB}	E_{TV} ^d	0.76	1.05	0.90	0.81	286.36	130
E_{SB}	E_{SW1} ^e	2.54	0.73	0.82	1.00	122.11	111
E_{SB}	E_{SW2} ^f	2.12	0.80	0.85	0.98	174.15	126
E_{SB}	V_{SW2} ^g	-5.88	0.00	0.63	1.56	50.42	126
E_{SB}	E_{TV}	0.58	1.05	0.86	0.98	1909.5	317
E_{SB}	E_{SW1}	2.83	0.68	0.77	1.21	232.5	286
E_{SB}	E_{SW2}	2.62	0.75	0.82	1.12	1438.2	325
E_{SB}	V_{SW2}	-6.59	0.004	0.61	1.12	127.3	325

^a Static bending MOE value.

^b Lowest continuous proof bending MOE value.

^c Average continuous proof bending MOE value.

^d Transverse vibration MOE value.

^e Longitudinal stress wave MOE value from Falcon A-grader.

^f Longitudinal stress wave MOE value from Director HM200.

^g Longitudinal stress wave velocity from Director HM200.

the sample standard deviation of the differences between predicted values and observed values, was also listed in terms of examining the possible reliability of the method for prediction purposes.

The linear regression analyses indicated that the regression models were statistically significant at the 0.05 confidence level. Overall, all of the NDT evaluations of in-grade No. 2 SP lumber were well correlated with the static bending MOE for all specimens with the coefficient of determinations being similar to 0.78 as found by Larsson (Larsson et al 1998) in Norway spruce. For the HCLT the coefficient of determination ($r^2 = 0.85$) was greater than that found by Bailleres et al (2012) in radiata pine ($r^2 = 0.70$). The linear regression plots for all lumber with size as a block factor are shown in Fig 5.

As to the results obtained from subsamples, the r^2 were found to be 0.78 (E_{SB} vs E_{LHCLT}), 0.85 (E_{SB} vs E_{HCLT}), 0.90 (E_{SB} vs E_{TV}), 0.82 (E_{SB} vs E_{SW1}), 0.85 (E_{SB} vs E_{SW2}), and 0.63 (E_{SB} vs V_{SW2}), respectively. Compared with the average MOE values that were obtained from HCLT machine, the lowest MOE values showed poorer

correlation with the static bending MOE for all specimens. Among all of the different tools, linear regression models built with NDT MOE obtained from the transverse vibration method yielded the highest r^2 value ($r^2 = 0.90$). Linear regression models built with the longitudinal velocity obtained from stress wave method yielded the lowest r^2 value ($r^2 = 0.63$).

As to the whole results obtained from the hand-held tools, linear regression models built with transverse vibration methods yielded the highest r^2 value ($r^2 = 0.86$) compared with other methods. The results from longitudinal stress wave method indicated that the direct results from Falcon, which reported a dynamic MOE value ($r^2 = 0.77$), showed higher accuracy compared with the Director HM200, which reported stress wave velocity ($r^2 = 0.61$). However, the results from Director HM200, dynamic MOE value that was deduced by Eq (2) yielded favorable prediction results ($r^2 = 0.82$).

Linear regression models were then developed for each lumber size (Table 4). Other than the continuous bending evaluation method, the results

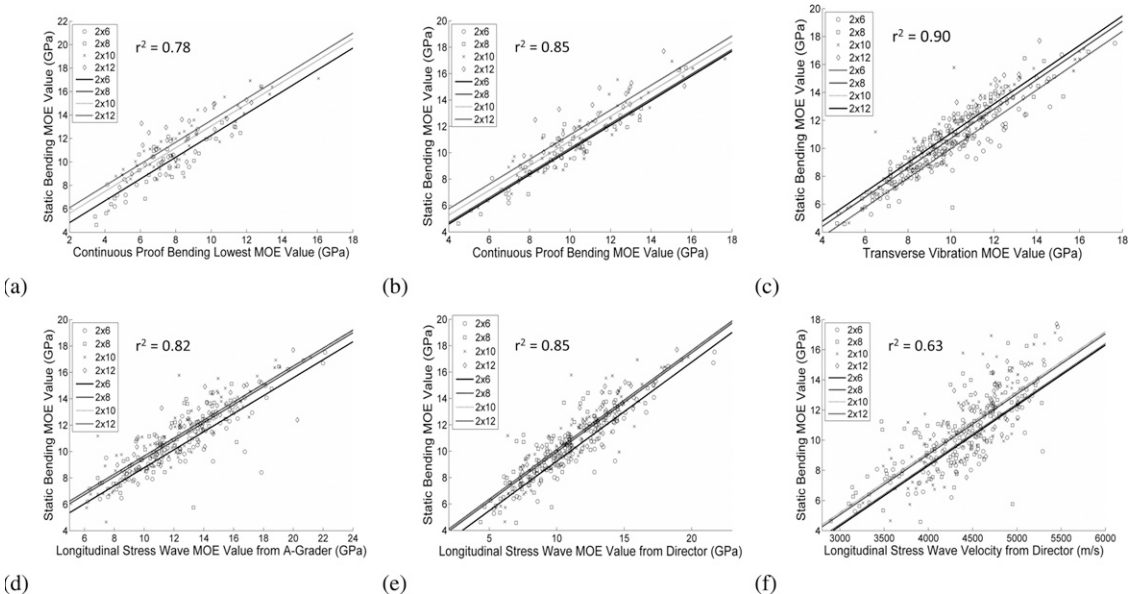

Figure 5. Linear regression plots considering lumber depth as a block variable: (a) E_{SB} and E_{LHCLT} ; (b) E_{SB} and E_{HCLT} ; (c) E_{SB} and E_{TV} ; (d) E_{SB} and E_{SW1} ; (e) E_{SB} and E_{SW2} ; (f) E_{SB} and V_{SW2} .

Table 4. Linear regression relationship for NDT MOE and static bending MOE value.

Size	y	x	β_0	β_1	r^2	RMSE	F value	Counts
2 × 6	E_{SB}^a	E_{LHCLT}^b	2.70	0.97	0.76	0.99	46.36	17
2 × 8	E_{SB}	E_{LHCLT}	2.80	0.95	0.77	1.23	107.22	33
2 × 10	E_{SB}	E_{LHCLT}	3.41	0.97	0.80	1.14	200.73	52
2 × 12	E_{SB}	E_{LHCLT}	5.68	0.76	0.52	1.47	26.98	27
2 × 6	E_{SB}	E_{HCLT}^c	0.98	0.92	0.88	0.69	111.44	17
2 × 8	E_{SB}	E_{HCLT}	1.01	0.93	0.89	0.86	249.06	33
2 × 10	E_{SB}	E_{HCLT}	1.23	0.97	0.85	1.00	276.76	52
2 × 12	E_{SB}	E_{HCLT}	3.35	0.80	0.62	1.30	40.79	27
2 × 6	E_{SB}	E_{TV}^d	0.43	0.99	0.87	0.71	104.25	17
2 × 8	E_{SB}	E_{TV}	-1.24	1.29	0.97	0.44	1038.06	33
2 × 10	E_{SB}	E_{TV}	1.29	1.00	0.86	0.96	310.31	53
2 × 12	E_{SB}	E_{TV}	1.64	0.97	0.88	0.74	181.85	27
2 × 6	E_{SB}	E_{SW1}^e	1.42	0.77	0.95	0.53	174.49	11
2 × 8	E_{SB}	E_{SW1}	2.65	0.69	0.83	0.82	119.18	27
2 × 10	E_{SB}	E_{SW1}	2.46	0.74	0.78	1.15	160.92	46
2 × 12	E_{SB}	E_{SW1}	2.29	0.75	0.76	1.04	77.50	27
2 × 6	E_{SB}	E_{SW2}^f	1.55	0.80	0.79	0.82	53.29	16
2 × 8	E_{SB}	E_{SW2}	1.40	0.82	0.93	0.63	418.30	32
2 × 10	E_{SB}	E_{SW2}	2.37	0.79	0.77	1.22	172.72	52
2 × 12	E_{SB}	E_{SW2}	2.34	0.78	0.80	0.94	97.36	26
2 × 6	E_{SB}	V_{SW2}^g	-3.16	0.003	0.51	1.26	14.83	16
2 × 8	E_{SB}	V_{SW2}	-6.69	0.004	0.66	1.42	58.78	32
2 × 10	E_{SB}	V_{SW2}	-6.17	0.004	0.51	1.80	51.61	52
2 × 12	E_{SB}	V_{SW2}	-9.14	0.005	0.56	1.41	30.16	26

^a Static bending MOE value.

^b Lowest continuous proof bending MOE value.

^c Average continuous proof bending MOE value.

^d Transverse vibration MOE value.

^e Longitudinal stress wave MOE value from Falcon A-grader.

^f Longitudinal stress wave MOE value from Director HM200.

^g Longitudinal stress wave velocity from Director HM200.

of the linear regression models built within lumber sizes showed no significant difference between groups. Among the results from the continuous bending evaluation method, the 2 × 12 size yielded the lowest r^2 values compared with the results from the other sizes. This result could be attributed to the long span length of the 2 × 12, and as the span increased there is a higher probability of a localized defect, such as a knot, influencing the static MOE in comparison with the dynamic MOE value, which represents the mean value over the full length (Ohlsson et al 2012). For all other NDT methods, prediction results varied slightly between lumber sizes and there was no observable relationship between lumber widths. These results agree with a previous study by Wang (2008), which found no side effects between lumber width and stress wave MOE rating of Douglas-fir structural lumber.

Multiple Linear Regressions

Other than lumber width, independent variables that could possibly influence the accuracy of linear regression model were considered in the multiple linear regression study. Multiple linear regressions (Eq 4) were built for further understanding of the regression models with multiple variables. Other than the NDT results (x_1) from tests, the physical conditions such as specific width of each piece of lumber (x_2), length (x_3), density (x_4), and MC (x_5) of lumber were also considered in the model according to the operation method of each tools.

$$y = \beta_0 + \beta_1 x_1 + \beta_2 x_2 + \beta_3 x_3 + \beta_4 x_4 + \beta_5 x_5 + \varepsilon \quad (4)$$

Model selection and validation was conducted in the SAS (2013) software using the STEPWISE

Table 5. Multiple linear regressions for dynamic MOE and static bending MOE value.

y	x	Intercept	NDT	Width	Length	Density	MC	RMSE	Multiple r_a^2	Linear r^2
		β_0	β_1	β_2	β_3	β_4	β_5			
E_{SB}	E_{LHCLT}	-4.06	0.77	0.01	— ^a	0.01	—	1.03	0.84	0.78
E_{SB}	E_{HCLT}	-3.60	0.83	0.01	—	0.01	—	0.94	0.88	0.85
E_{SB}	E_{TV}	-2.36	1.00	0.02	-0.75	—	0.23	0.89	0.89	0.86
E_{SB}	E_{SW1}	0.38	0.65	—	0.23	NA ^b	0.14	1.21	0.77	0.77
E_{SB}	E_{SW2}	0.03	0.72	—	0.29	NA ^b	0.12	1.11	0.82	0.82

^a Not significant at $\alpha = 0.05$.

^b Density has been used to calculate the MOE value from longitudinal stress wave method according to the equations. To avoid multilinearity, it is not considered as a variable in the multiple regression models.

function to select the best multiple linear regression model and by using the PRESS function to verify the selected model. The model information in Table 5 lists the variables contained in the model ($\alpha \leq 0.05$).

Adjusted coefficient of multiple determination (r_a^2) expresses the percentage of the total variability explained by the regression model. Overall, the results obtained from the given NDT techniques showed that there was slightly or no significant difference of r_a^2 compared with that of the single-variable linear regression models and consequently there was no practical reason to include variables other than NDT MOE values.

A multiple linear regression model was also built to include both E_{LHCLT} and E_{HCLT} . As a result, the E_{LHCLT} was not significant at $\alpha = 0.05$ and was not selected as an effective parameter in this model. Thus, a multiple regression model with the lowest and average NDT MOE values is also not recommended from the result in this study.

CONCLUSIONS

This study investigated the reliability of four commercial NDT techniques in predicting the static bending MOE value on in-grade No. 2 SP lumber. A mobile Metriguard Model 7200 HCLT was setup to conduct the continuous bending evaluation method, a Metriguard Model 340 Transverse Vibration MOE-computer was used to conduct the transverse vibration method, and a Falcon Engineering A-Grader and a Carter Holt Harvey Director HM200 were adopted as testing tools to conduct the longitudinal stress

wave evaluations. The results of this study suggest the following:

- 1) The MOE value of on-grade No. 2 SP lumber can be readily predicted by the continuous bending (HCLT), transverse vibration, and longitudinal stress wave techniques.
- 2) The total variability explained by the linear regression models for all lumber sizes was 86% for HCLT technique and transverse vibration technique, 77% (Falcon), and 82% (Carter Holt Harvey Director HM200) for the two of the longitudinal stress wave techniques that were conducted in the study.
- 3) As to the longitudinal stress wave techniques, the r^2 was similar for both Falcon Engineering A-Grader ($r^2 = 0.77$) and Carter Holt Harvey Director HM200 ($r^2 = 0.82$) technologies when correlating the static MOE and dynamic MOE values.
- 4) There was no sufficient evidence to conclude that the physical conditions (lumber depth, length, density, and MC) were valuable for improving the accuracy of the models. Multiple linear regression method with selected parameters was not recommended to predict the actual bending stress value while using the given NDT tools in this study.

ACKNOWLEDGMENTS

The authors wish to acknowledge the support of U.S. Department of Agriculture (USDA), Research, Education, and Economics (REE), Agriculture Research Service (ARS), Administrative and Financial Management (AFM), Financial Management

and Accounting Division (FMAD), Grants and Agreements Management Branch (GAMB), under Agreement No. 5B-0202-4-001. Any opinions, findings, conclusion, or recommendations expressed in this publication are those of the author(s) and do not necessarily reflect the view of the U.S. Department of Agriculture. The authors also wish to thank Metriguard for making the mobile High Capacity Lumber Tester available for a day at the laboratory.

REFERENCES

- Achim A, Paradis N, Carter P, Hernandez RE (2011) Using acoustic sensors to improve the efficiency of the forest value chain in Canada: A case study with laminated veneer lumber. *Sensors (Basel Switzerland)* 11(6): 5716-5728.
- American Society for Testing and Materials (2014) Standard test methods of static tests of lumber in structural sizes. D198-14. ASTM International, West Conshohocken, PA.
- Bailleres H, Hopewell G, Boughton G, Brancheriau L (2012) Strength and stiffness assessment technologies for improving grading effectiveness of radiata pine wood. *BioResources* 7(1):1264-1282.
- Dahlen J, Jones PD, Seale RD, Shmulsky R (2014) Bending strength and stiffness of wide dimension southern pine No. 2 lumber. *Eur J Wood Wood Prod* 72(6): 759-768.
- Galligan WL, McDonald KA (2000) Machine grading of lumber: Practical concerns for lumber producers. Forest Products Laboratory Gen Tech Rep FPL-GTR-7 USDA For Serv Forest Prod Lab, Madison, WI. 39 pp.
- Jones E (1989) Sampling procedures used in the in-grade lumber testing program. Pages 11-14 *in* In-grade testing of structural lumber. Forest Products Society, Madison, WI.
- Halabe UB, Bidigalu GM, GangaRao HVS, Ross RJ (1997) Nondestructive evaluation of green wood using stress wave and transverse vibration techniques. *Mater Eval* 55(9):1013-1018.
- Kretschmann DE, Green DW (2010a) Lumber stress grades and design properties. Wood handbook. Gen Tech Rep FPL-GTR-190 USDA For Serv Forest Prod Lab, Madison, WI. 15 pp.
- Kretschmann DE (2010b) Stress grades and design properties for lumber, round timber, and ties. Wood handbook. Gen Tech Rep FPL-GTR-190 USDA For Serv Forest Prod Lab, Madison, WI. 17 pp.
- Larsson D, Ohlsson S, Perstorper M, Brundin J (1998) Mechanical properties of sawn timber from Norway spruce. *Holz Roh-Werkst* 56(5):331-338.
- Ohlsson S, Oscarsson J, Johansson M, Kallsner B (2012) Prediction of timber bending strength on basis of bending stiffness and material homogeneity assessed from dynamic excitation. *Wood Sci Technol* 46(4):667-683.
- Ross RJ, Geske EA, Larson GR, Murphy JF (1991) Transverse vibration nondestructive testing using a personal computer. Res Rep FPL-RP-502 USDA For Serv Forest Prod Lab, Madison, WI. 17 pp.
- Ross RJ, Pellerin RF (1994) Nondestructive testing for assessing wood members in structures, a review. Gen Tech Rep FPL-GTR-70 USDA For Serv Forest Prod Lab, Madison, WI. 40 pp.
- SAS (2013) SAS Institute Inc. Version 9.4. Cary, NC.
- SFPA (2005) Industry statistics: Annual production from 2000 to 2005. Southern Forest Products Association. New Orleans, LA.
- U.S. Census Bureau (2012) Lumber production and mill stocks: 2010. Census Bureau, Washington, DC. http://www.census.gov/manufacturing/cir/historical_data/ma321t/ma321t10.xls (27 June 2012).
- Wang X, Ross BJ, Mattson JA, Erickson JR, Forsman JW, Geske EA, Wehr MA (2002) Nondestructive evaluation techniques for assessing modulus of elasticity and stiffness of small-diameter logs. *Forest Prod J* 52(2):79-85.
- Wang X (2008) Effects of size and moisture on stress wave E-rating of structural lumber. Pages 1469-1476 *in* Proc. 10th World Conference on Timber Engineering, June 2-5, 2008, Miyazaki, Japan.