

REDUCTION IN THE REGENERATION ENERGY OF CO₂ CAPTURE PROCESS BY IMPREGNATING AMINE SOLVENT ONTO PRECIPITATED SILICA

Dang Viet Quang, PhD

Aravind V. Rabindran, PhD

Nabil El Hadri, PhD

Mohammad R. M. Abu-Zahra, PhD

The Institute Center for Energy (iEnergy),
Masdar Institute of Science and Technology, Abu Dhabi, UAE

Abstract

High energy required for the regeneration of aqueous amine solution is a great challenge for conventional CO₂ capture technology to be deployed on large scale. Finding novel adsorbent with low regeneration energy and cost-effectiveness for CO₂ capture is an impetus for researchers. In this study, precipitated silica (PS) was synthesized and impregnated with various amines including 2-aminomethylpropanol (AMP), monoethanolamine (MEA), diethanolamine (DEA) and polyethyleneimine (PEI) to produce solid adsorbents. The CO₂ adsorption capacity, heat capacity, and adsorption heat of adsorbents were determined. The results were used to calculate the regeneration heat of CO₂ adsorption process, which then was compared with the conventional aqueous MEA 30 wt% based process. The results indicated that MEA impregnated PS (60 wt%) has the highest CO₂ adsorption capacity; up to 5.3 mmole/g and PEI impregnated PS (50 wt%) has the lowest adsorption capacity among prepared solid adsorbents; 2.9 mmole/g, which is, however, higher than that of aqueous MEA 30 wt% (2.7 mmole/g). The regeneration heat required for the solid adsorbents substantially decreased in comparison with aqueous MEA 30 wt%. Regeneration heat required for PEI impregnated PS (50 wt%) was 2080 kJ/kg of CO₂ that is 46.7% lower than that of aqueous MEA 30 wt%. The obtained results demonstrated that the impregnation of amine onto PS is a viable method to reduce the regeneration energy of CO₂ capture process.

Keywords: Adsorption capacity, CO₂ capture, regeneration heat, sensible heat, precipitated silica

Introduction

The increasing CO₂ emission has attracted much concern from scientist community and authorities because it is a main culprit that causes global warming (UNEP 2013). Although many efforts have been taken worldwide to mitigate CO₂ emission (IPCC 2005; FutureGen 2011; EPA 2013), recent data have indicated that the concentration of CO₂ in atmosphere is still increasing (MLO). Therefore, viable and imperative methods to reduce of CO₂ emission into atmosphere are really necessary. Since fossil fuel fired power plants have been attributed to the largest source of anthropogenic CO₂ emission, most of CO₂ separation and capture technologies has focused on the capture of CO₂ exhausted from those power plants. Those technologies include pre-combustion, oxyfuel combustion, and post-combustion capture (IPCC 2005; Maththias 2010; Mondal, Balsora et al. 2012). Among them, the post-combustion capture is very important because it can easily retrofit to the fleet of existing fossil fuel fired power plants (Geisbrecht and Dipietro 2009; Chung, Patiño-Echeverri et al. 2011; Wang, Lawal et al. 2011). Up to date, various technologies have been proposed for the post-combustion capture such as cryogenic separation, membrane separation, and absorption (Wilson and Gerard 2007). In which, chemical absorption with aqueous alkanolamine solvents is the most advanced and well known technology (Mondal, Balsora et al. 2012; Reynolds, Verheyen et al. 2012).

A variety of amine solvents have been investigated for CO₂ capture (Lee, Kim et al. 2009; Rochelle, Chen et al. 2011; Wang, Lawal et al. 2011; Artanto, Jansen et al. 2012; Mondal, Balsora et al. 2012). In which, aqueous solution of monoethanolamine (MEA) is most well-known solvent that has been used and commercialized for the CO₂ separation from natural gas (Kohl and Nielsen 2011). MEA is a primary amine, which readily reacts with CO₂ to form carbamate. Aqueous solution of MEA is the most effective solvent to capture CO₂, even at the low concentration of CO₂ in the atmosphere. Several works have been carried out to demonstrate its possibility and feasibility for the capture of CO₂ from flue gas at pilot scale (Idem, Wilson et al. 2005; Feron, Abu-Zahra et al. 2007; Artanto, Jansen et al. 2012).

The MEA solvent and its blends usually have a high CO₂ adsorption capacity and strong affinity to CO₂. However, CO₂ capture technology using MEA requires much energy for the regeneration of amine solvent. The estimated energy penalty for CO₂ capture by MEA solvent is about 23—30 % of the energy output of power plant (Abu-Zahra, Schneiders et al. 2007; Abu-Zahra, Niederer et al. 2007). The reduction in the electricity output causes the significant increase in the cost of electricity (about 80%). Investigators have spent much effort on reducing the regeneration energy of CO₂ capture process. An effective CO₂ capture technology should consume a

minimum regeneration energy, which includes energy to heat CO₂ loaded absorbent to a regeneration temperature (100-130 °C), the heat of the evaporation of solvent, and desorption heat that is the energy required to desorb CO₂. The desorption heat is actually the heat of CO₂ absorption, which mostly depends on the molecular characteristics of amine compounds. The primary and secondary amines can react with CO₂ as described in equation (1) and (2), in which, they form carbamate in the absence of water and bicarbonate in the presence of water (3). The tertiary amines only react with CO₂ in the presence of water to form carbonate products (3). Generally, the order of the adsorption heat of amines is primary amines > secondary amines > tertiary amines (Kim and Svendsen 2007; Maiti, Bourcier et al. 2011). Required energy to increase the temperature of sorbent and the evaporation heat depend on the characteristics of solvents such as specific heat and CO₂ adsorption capacity. Conventional aqueous amine solvents consume much energy to heat a large amount of water (about 70%), which have a high specific heat capacity. Additionally, the increase in temperature often accompanies with the evaporation of water and amine, which causes extra energy consumption. High energy consumptions make conventional CO₂ capture process using aqueous solvent difficult to be deployed at large scale.

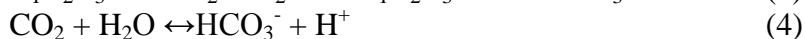
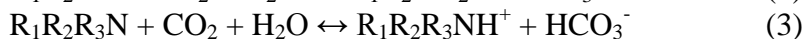
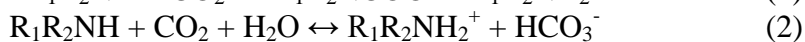

Recently, investigators have tried various methods to reduce regeneration energy of CO₂ capture process. Impregnation of amine onto solid substrates to produce solid adsorbents is considered to be the most viable method (Filburn, Helble et al. 2005; Samanta, Zhao et al. 2011). Ebner et al immobilized polyethylenimine onto CARiACT G10 silica. The resulting adsorbent has adsorption capacity of 0.25-2.8 mmole/g and the heat of adsorption of 50 kJ/mole (Ebner, Gray et al. 2011). Knowles et al functionalized mesoporous silica with 3-aminopropyltriethoxysilane to make an adsorbent with CO₂ adsorption capacity up to 7 % (1.59 mmole/g) with the heat of adsorption of 60 kJ/mole (Knowles, Graham et al. 2005). Sun et al. prepared MEA-TiO₂ for CO₂ adsorption by the impregnation of as-purchased MEA onto TiO₂ (Sun, Fan et al. 2011; Sun, Fan et al. 2011). Their results indicated that the activation energy of CO₂ desorption process is 80.79 kJ/mole, which reduced considerably compared to 114 kJ/mole of aqueous MEA solution. Obviously, solid absorbent helps reduce desorption heat; however, the most benefit of it is the avoidance of vaporization heat that account for about 30 to 50% of regeneration energy (Abu-Zahra 2009).

A number of works have reported the use of mesoporous silica to impregnate amine for CO₂ capture; however, most of them deal with order porous silica like SBA-15 and CMC-41. Precipitated silica has large surface area, large pore size, high porosity, and very lower cost compared to SBA-15 and CMC-41. It may be suitable for CO₂ capture absorbent, but only few works has investigated the use of precipitated silica (Ichikawa, Seki et al. 2010). Therefore, our objective is to synthesize and use precipitated silica as a porous substrate to impregnate various amine solvents and then study their ability to adsorb CO₂. In this study, we analyze heat capacity, the heat of CO₂ adsorption, and CO₂ adsorption capacity of amine impregnated precipitated silica. Obtained data were used to calculate the regeneration energy and compared with the case of aqueous MEA 30 %.

Experimental

Materials

Ethanolamine (MEA, 99%), 2-aminomethylpropanol (AMP, 97%), diethanolamine (DEA, 99%), branched polyethyleneimine (PEI, Mw 1300, 50 % in water), sodium chloride (99.5%), and sulfuric acid (98%) were purchased from Sigma-Aldrich. Sodium silicate was supplied by Blue line Chemicals Company. All amine solvents were used without any further purification.

Preparation of precipitated silica

The preparation procedure of precipitated silica (PS) was adapted from previous publications (Quang, Sarawade et al. 2011; Sarawade, Kim et al. 2011; Quang, Kim et al. 2012). Typically, 26 g of sodium chloride was dissolved in 698 g of water in a 3 L beaker placed in a heating mantle. Until sodium chloride was completely dissolved, 189 g of sodium silicate solution (3.4SiO₂·NaO₂) was added. The heating mantle was turned on and temperature was set at 40 °C. When temperature reached 40 °C, H₂SO₄ 8 % was added by a drop wise method. H₂SO₄ was added by two stages. The first stage was ended as the first silica aggregates observed. The second stage began after 5 min from the end of the first and finished at pH 5. Resulting slurry was aged at 80 °C for 30 min and cooled down to room temperature. The slurry was filtered and washed with water to eliminate by-product ions, mainly including Na⁺, SO₄²⁻, and Cl⁻. Finally, PS was obtained by drying wet slurry at 130 °C for 3 h.

Preparation of adsorbents

Preparation of polyethyleneimine impregnated silica

The desired amount of PEI 50 wt% in water was diluted with distilled water to prepare impregnating solutions. PEI impregnated precipitated silica

was prepared by a wet impregnation method. Typically, 4 g of impregnating solution was added to a 50 mL beaker containing 1 g of precipitated silica and mechanically mixed using a steel stainless spatula. PEI impregnated precipitated silica was obtained by drying silica slurry at 105 °C for 3 h. The prepared adsorbents were denoted as PEI-PS-x, where x is the weight percentage of PEI in the adsorbent.

Preparation of AMP, MEA and DEA impregnated silica

In order to prepare amine solvent impregnated silica, the desired amount of specific amine solvent was dropwise added to a 25 mL beaker containing 1 g of silica, which was mechanically mixed using a steel stainless spatula. The prepared adsorbents were denoted as AM-PS-y, where AM is the amine solvent which is AMP, MEA, or DEA and y is its weight percentage in the adsorbent.

Characterization

The Brunauer-Emmett-Teller (BET) surface area, pore size and pore volume of the precipitated silica were analyzed using a nitrogen adsorption-desorption instrument (Micromeritics Tristar 3000 porosimeter). Samples were measured after degassing at 100 °C for 3 h. The porosity and pore size distribution was calculated using the Barrett-Joyner-Halenda (BJH) method (Lowell, Shields et al. 2004). Scanning electron microscope (Quanta 250) was used to study the morphology of silica substrate at the accelerating voltage of 15kV. Thermogravimetric analysis (TGA) was performed using a thermogravimetric analyzer (SDT Q600). TGA was performed in nitrogen gas at a heating rate of 5 °C/min from room temperature to 900 °C.

Measurement of heat capacity

Heat capacity was determined by a Micro Reaction Calorimeter provided by Thermal Hazard Technology (UK). Heat capacity was measured at temperature ranging from 30—90 °C. At each temperature, the heat was repeatedly measured 3 times with a step of ± 0.5 °C. First, blank test was conducted with an empty cell. Then, approximate 0.3 g of adsorbent was placed in analysis cell and conducted test with the same condition used for the blank. The heat capacity of adsorbent was calculated from equation 5, where C_p (J/°C*g) is the heat capacity of adsorbent, m is the mass of sample (g), ΔT is temperature step (1 °C) and Q (J) and Q_{blank} (J) are the heat change of analysis cell with sample and without sample respectively.

$$C_p = \frac{(Q - Q_{\text{blank}})}{m \cdot \Delta T} \quad (5)$$

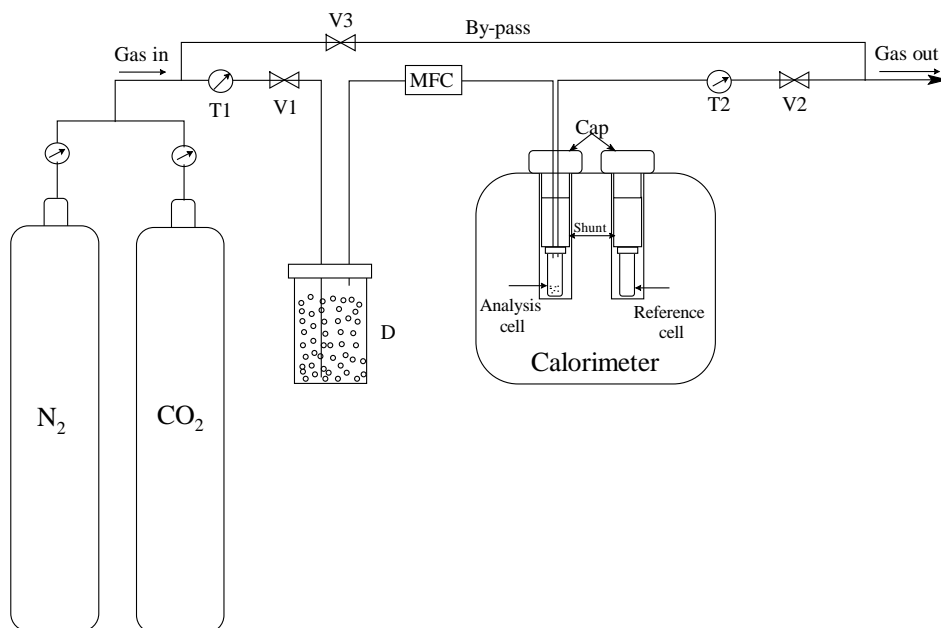

Figure 1. Schematic diagram of CO₂ adsorption process using a flow Micro Reaction Calorimeter

CO₂ loading capacity and the heat of CO₂ adsorption

The heat of adsorption was determined by a flow Micro Reaction Calorimeter (URC) provided by Thermal Hazard Technology (UK). An analysis cell containing approximate 0.2 g of adsorbent was installed in analysis cell as shown in Figure 1. CO₂ gas supplied from a cylinder was run through a desiccant column (D) to remove moisture before entering the analysis cell. The flow rate of CO₂ was controlled by a mass flow controller (MFC). The valve V2 was used to control the pressure of system that was indicated by a transducer (T2). Test was run by URC control software under the isothermal mode and result was displayed as the variation of power (mW) with time (s). When the power signal becomes constant, CO₂ gas was introduced at the rate of 0.3 ml/min. Since the reaction between CO₂ gas and adsorbent is exothermic, the power signal increased right after the gas was flowed into analysis cell. Test was completed when the power signal becomes constant again. The weight of adsorbent before and after the test was checked to calculate the mass of CO₂ adsorbed. The integral heat (Q) was computed by using URC analysis software provided by Thermal Hazard Technology. The heat of adsorption ΔH (kJ/mole of CO₂) was calculated by dividing the integral heat by the mole of CO₂ absorbed. The CO₂ adsorption capacity of adsorbent (mg/g) was calculated by dividing the quantity of CO₂ adsorbed per the mass of adsorbent. To reaffirm the CO₂ loading capacity of adsorbent, CO₂ were analyzed by a CO₂ analytical system designed by

Masdar Institute. Accordingly, CO₂ loading samples were brought to react with H₃PO₄ acid in a three-neck flash at about 110 °C to release CO₂ gas, which was carried by N₂ gas to a CO₂ detector, where CO₂ concentration was detected and recorded by computer software. The CO₂ adsorption capacity was calculated by dividing the total amount of CO₂ released from sample per the mass of sample.

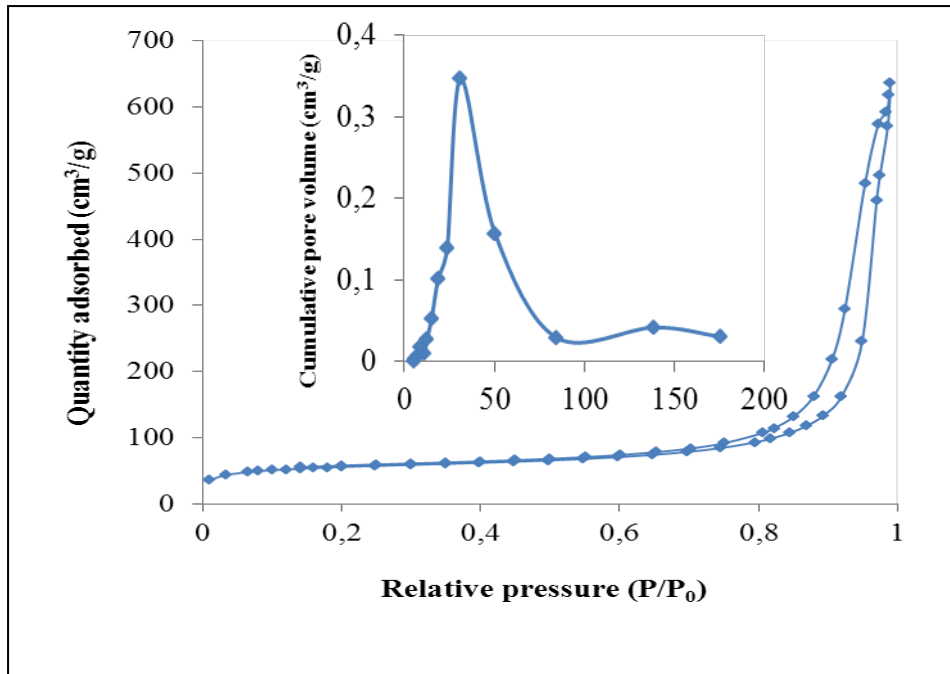

Figure 2. Nitrogen adsorption-desorption isotherm and pore volume distribution of precipitated silica

Results and discussion

Characterization of adsorbent

Nitrogen adsorption-desorption isotherm and pore size distribution of the synthesized PS are shown in Figure 2. The hysteresis loop is associated with type IV according to IUPAC classification indicating that PS is a mesoporous material. However, this loop does not show any limiting adsorption at high relative pressure (P/P₀), which implied that PS contains slit-shaped pores formed by non-rigid aggregates of plate-like particles (Lowell, Shields et al. 2004). In CO₂ adsorbents, pores are considered as accommodation for amines, which are active sites to capture CO₂. Thus, the pore volume and pore size distribution of substrate have a very important role in enhancing adsorption ability of the resulting adsorbent. In this work, the porosity and pore size distribution was calculated by the Barrett-Joyner-Halenda (BJH) method using desorption isotherm. The BET surface area and

total pore volume of PS are $230 \text{ m}^2/\text{g}$ and $0.93 \text{ cm}^3/\text{g}$, respectively. Figure 2, (inset) revealed that PS has a broad pore size distribution, beside the majority of pores (about 90%) with diameter ranging from 20–80 nm, a small fraction of pores with the diameter greater than 100 nm was observed. It is most likely that the larger pores were interstices formed during the flocculation of aggregates, while the small pores were tiny cavities formed among primary silica particles. This assumption is consistent with the observation from SEM image (Figure 3), where, the structure of PS can be seen as a network of connecting silica particles. Silica particles were randomly bonded together and therefore, the pores, which are interstices among silica particles, with different sizes and shapes were formed. According to percolation theory, the pores in the precipitated silica are unoccupied sites formed during the flocculation of primary silica particles and aggregates (Quang, Kim et al. 2012).

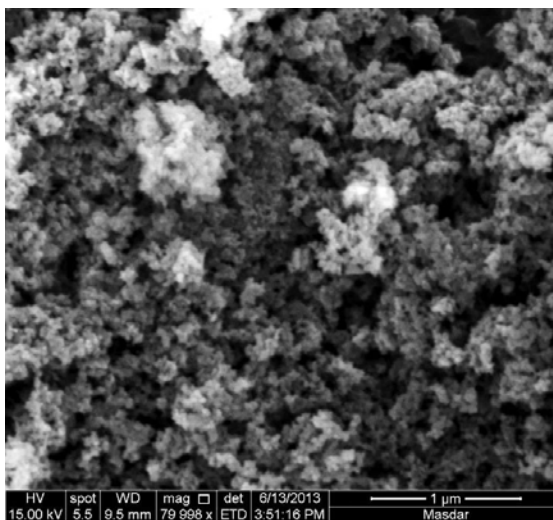

Figure 3. A SEM image of precipitated silica

The thermal stability of silica impregnated with different amines was analyzed using a TGA and results are shown in Figure 4. The results indicated that PS is a thermal stable material (Figure 4 a). At about $100 \text{ }^\circ\text{C}$, the weight loss of silica is mostly related to the evaporation of physically adsorbed water (approximate 5%). From $100\text{--}900 \text{ }^\circ\text{C}$, the gradual reduction in the weight of sample is attributed to the loss of structural water including bonding water and the water that can be eliminated by the condensation of silanol groups (Si-OH) to form siloxane linkages (Si-O-Si). All amine impregnated adsorbents showed a less thermal stability. The TGA profiles of AMP-PS (Figure 4 b) and MEA-PS (Figure 4 c) depict two weight loss regions, a steep regions from room temperature to $110 \text{ }^\circ\text{C}$ on the curve of

AMP-PS-60 and 120 °C on that of MEA-PS-60 are assigned to the rapid evaporation of AMP and MEA, respectively. On the TGA profiles of DEA-PS (Figure 4 d) and PEI-PS (Figure 4 e), three weight loss regions were observed. The region at about 100 °C is attributed to the evaporation of adsorbed water. The rapid decrease of sample weight of DEA-PS-60 at 150–200 °C belongs to the vaporization of DEA and that of PEI-PS-60 at 300-400 °C is due to the degradation of PEI. It is evident that PEI-PS is the most thermal resistant adsorbent among amine-impregnated silica. This is understandable because PEI is a polymer, which has higher thermal stability compared to other amine solvents.

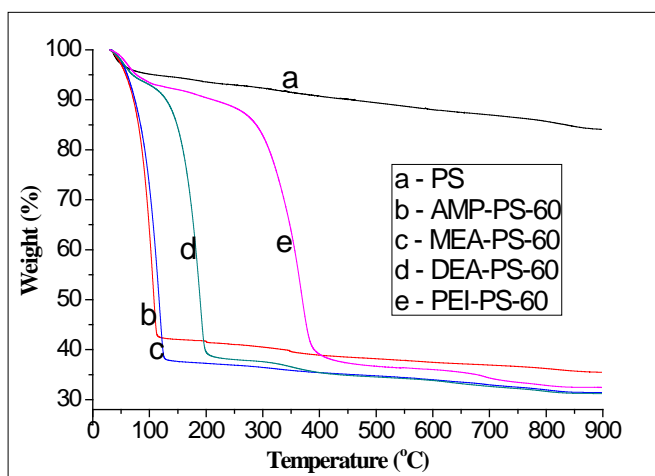

Figure 4. TGA profiles of PS (a), AMP-PS-60 (b), MEA-PS-60 (c), DEA-PS-60 (d), and PEI-PS-60 (e)

The thermal stability is one of the most important properties of adsorbents for CO₂ capture because a CO₂ capture process is usually associated with thermal regeneration of adsorbents. The regeneration process is conducted at about 100-130 °C; therefore, adsorbents with a higher thermal stability are preferable. Depending on thermal stability of sorbents, different adsorption/desorption column and technique would be designed. For high thermal stable adsorbent, typical adsorption/desorption techniques such as fixed-bed adsorption or fluidized-bed adsorption can be applied, but for the less thermal stable adsorbent like MEA-PS, the adsorption/desorption technique needs a significant modification. Because, the evaporation of MEA occurs together with CO₂ desorption at regeneration temperature, Sun et al. proposed a modified fixed-bed adsorption process, where adsorption column has two regions, one region contains MEA-TiO₂, a CO₂ adsorption

and another region contains TiO_2 to adsorb MEA evaporated during CO_2 desorption (Sun, Fan et al. 2011).

CO₂ adsorption capacity

The adsorption performance of adsorbents was investigated and the results were shown in Table 1. Before amine was impregnated, the adsorption capacity of PS was 0.6 mmole/g. The adsorption capacity of silica substrate is very low, which is similar to previous observation on various types of porous silica (Xu, Song et al. 2002; Knowles, Graham et al. 2005; Ichikawa, Seki et al. 2010; Zhao, Shen et al. 2012). The low adsorption capacity is due to the weak interaction between CO_2 and silica substrate. The silica contains a large number of silanol groups ($-\text{SiOH}$) on the surface, but those groups have very low affinity to CO_2 . Ichikawa et al. assumed that the adsorption of CO_2 on precipitated silica is due to the confinement of CO_2 in the small and bottle-like pores (Ichikawa, Seki et al. 2010). Previous studies indicated that the immobilization or impregnation of amine onto silica can substantially enhance its CO_2 adsorption capacity. Therefore, in this study, we impregnated different kinds of amines (AMP, MEA, DEA, and PEI) onto silica to investigate their effect on the improvement of adsorption capacities of adsorbents.

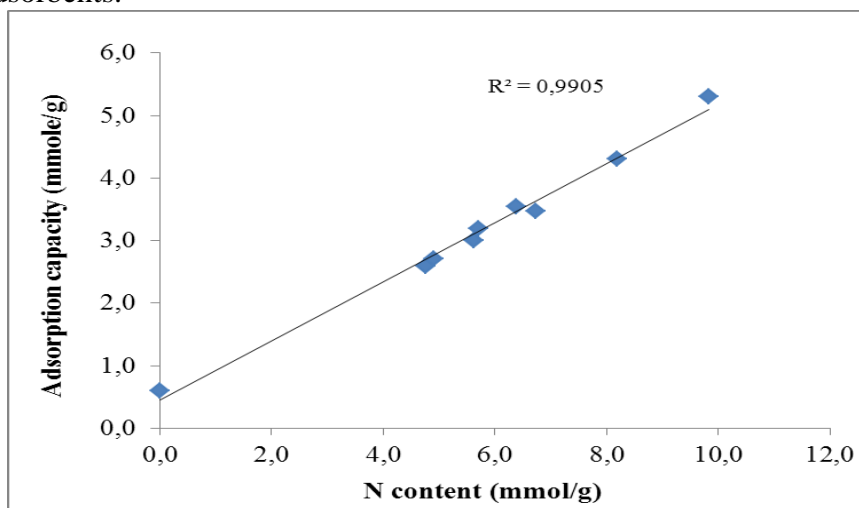

Figure 5. Variation in adsorption capacity of sorbent with nitrogen contents

In this work, the adsorption capacities of aqueous MEA solution, AMP-PS, MEA-PS and DEA-PS were measured at 40 °C to reduce the vaporization of amines, while that of PEI-PS was carried out at 75 °C to maximize its adsorption capacity. The results obtained indicated that the adsorption capacity of PS increased significantly after being impregnated with amines. As shown in Table 1, MEA-PS is the best adsorbent in term of adsorption capacity and followed by AMP-PS, DEA-PS, and PEI-PS. The adsorption capacities of MEA-PS containing 50% and 60 % MEA were 4.3

and 5.3 mmole/g, respectively. DEA-PS had the lowest adsorption capacity among the prepared adsorbents. The 50% DEA impregnated PS adsorbed only 2.6 mmole/g of sorbent, which is almost similar to 30% aqueous MEA solution (2.7 mmole/g). Obviously, the adsorption capacities of solid sorbents vary with types of impregnated amines and their concentration. The reactions between amine and CO₂ were described in equation (1), (2), and (3). Accordingly, one mole of primary and secondary amine can react with 0.5 mole of CO₂ in the absence of water and up to 1 mole of CO₂ in the presence of water. However, the rate of reaction (2) is slow and depends on that of reaction (4), where the dissolution of CO₂ in water to form carbonic acid occurs very slowly at low pressure. In this study, one mole of amine in solid sorbent except PEI can adsorb 0.51-0.56 mole of CO₂, which is similar to the case of aqueous MEA solution, in which amine can react with CO₂ to form carbamate (Xie, Zhou et al. 2010). The experimental molar ratios of CO₂ to amines in both solid and liquid are slightly higher than theoretical calculation. The increase in molar ratio of CO₂ to amine in comparison with theoretical calculation is likely due to the physical adsorption of CO₂ onto the adsorbents.

Table 1. Adsorption capacity of adsorbents

Sample	Amine loading (mmole-N/g)	Adsorption capacity (mmole/g)	Molar ratio of CO ₂ /amine	Temperature (°C)
Silica	0.0	0.6	-	40
Aqueous MEA-30	4.9	2.7	0.54	40
DEA-PS-50	4.8	2.6	0.55	40
DEA-PS-60	5.7	3.2	0.56	40
AMP-PS-50	5.6	3.0	0.53	40
AMP-PS-60	6.7	3.5	0.51	40
MEA-PS-50	8.2	4.3	0.53	40
MEA-PS-60	9.8	5.3	0.54	40
PEI-PS-50	11.6	2.9	0.25	75
PEI-PS-60	13.9	3.1	0.22	75

The CO₂ adsorption capacities of PEI-PS-50 and PEI-PS-60 are 2.9 mmole/g and 3.1 mmole/g, respectively. The molar ratios of CO₂ to total nitrogen in sorbents, which include primary, secondary, and tertiary amines, are only 0.22 for 60% PEI and 0.25 for 50% PEI, respectively. Obviously, the adsorption capacities of PEI-PS increase as the concentration of impregnated PEI increase from 50 to 60%, but the molar ratios of CO₂ to nitrogen decrease as the concentration of impregnated PEI increases. The molar ratios of CO₂ to nitrogen in PEI-PS are much lower than that of CO₂ to nitrogen in other monomer amine-impregnated PS. This is most likely due to the deactivation of tertiary amino groups in PEI, which do not react with CO₂ in the absence of water. Moreover, PEI is a polymer, whose long molecules

is likely to be packed or blocked in the pores of silica as the loading amount of PEI increases, and this leads to reduce the accessibility of CO₂ molecules to active sites, amino groups. Many amino groups in PEI-PS are unable to react with CO₂ and therefore, these results in the reduction of the molar ratios of absorbed CO₂ to total nitrogen in sorbents as the loading amount of PEI increases. The obtained results are in congruence with the observation of previous studies (Xu, Song et al. 2002; Chen, Yang et al. 2009) in which the adsorption capacities of PEI impregnated silica increase with the increase in PEI loading. However, the adsorption capacities reach a maximum value at a specific PEI loading (50–65%) and reduce at higher PEI loading due to the less accessibility to amino groups.

To compare the activity of different monomer amines impregnated in silica and blended with water, we prepared adsorbents by impregnating different amounts of AMP, MEA and DEA onto silica and measured their adsorption capacities. The loading amounts of amine onto silica are not greater than a saturated adsorption point of silica, where silica fully absorbs solvent and becomes slurry if further solvent is added. Nitrogen contents in both solid sorbents and aqueous solutions were calculated and the relation of nitrogen contents with the adsorption capacity of adsorbents was presented in Figure 5. The results indicated that the adsorption capacity of low molecular primary and secondary amine-containing sorbents increases linearly with the increase of the nitrogen content in sorbents, irrespective of whether amine impregnated onto porous silica or dispersed in water. Therefore, in the case of low molecular amines with their loading onto silica below the saturated adsorption point, the higher adsorption capacity of the solid adsorbents is attributed to the higher concentration of amino functional group loaded onto silica.

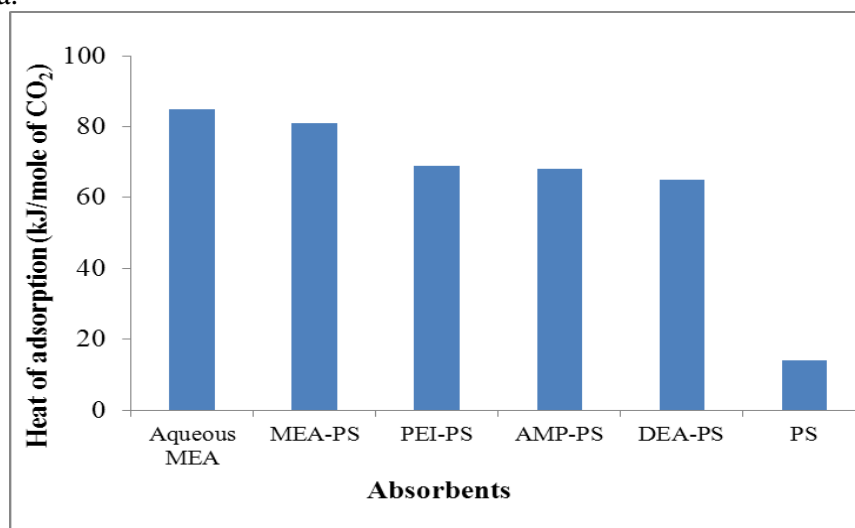

Figure 6. Adsorption heat of adsorbent impregnated with different types of amine

Heat of adsorption

The CO₂ adsorption process is based on reversible reactions between CO₂ and amino groups as described in equation (1), (2) and (3). To regenerate amines, a significant amount of heat, that is equal to the CO₂ adsorption heat, must be supplied to decompose carbamate and carbonate products. In this work, the heat of CO₂ adsorption of the prepared adsorbents is shown in Figure 6. From this figure, we can see that the adsorption heat of PS was very low, 14 kJ/mole of CO₂. As discussed above, the silica substrate has a very low CO₂ adsorption capacity due to weak interaction with CO₂. Thus, the low adsorption capacity and adsorption heat demonstrated that the adsorption of CO₂ onto silica is physical adsorption. The results revealed that aqueous MEA has the highest adsorption heat that is about 85 kJ/mole of CO₂. The adsorption heat slightly decreases after MEA was impregnated onto PS; it is 81 kJ/mole of CO₂. DEA-PS has the lowest adsorption heat among the prepared adsorbents; it is 65 kJ/mole of CO₂. The adsorption heat of PEI-PS and AMP-PS are 69 and 68 kJ/mole of CO₂, respectively. Previous study indicated that the bonding strength of CO₂ to secondary amino groups is less than that of primary amino groups, which results in the lower CO₂ adsorption heat of secondary amines (Carson, Marsh et al. 2000; da Silva and Svendsen 2005; Kim and Svendsen 2007).

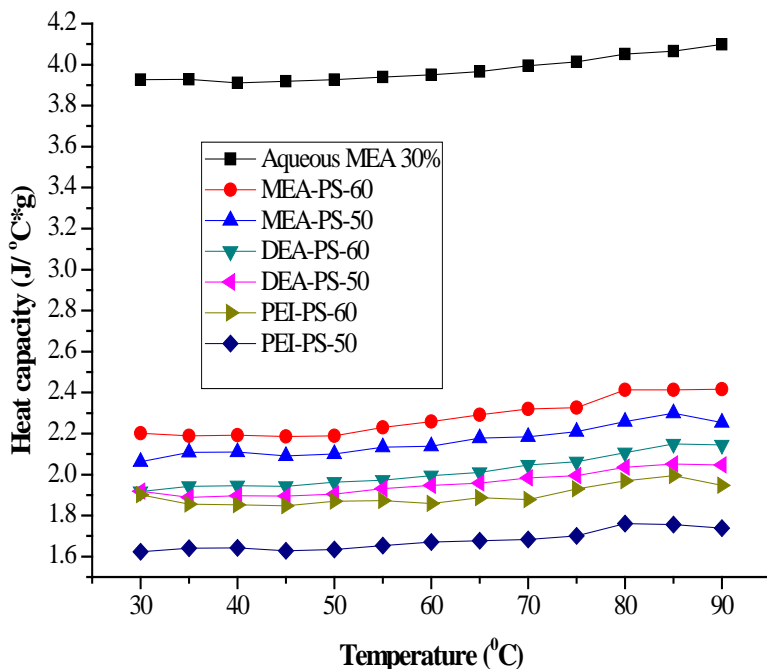

Figure 7. The heat capacity of sorbents from 30-90 °C

Heat capacity

Heat capacity data of adsorbent is an important parameter required for the design of heat exchange used in gas separation processes. In CO₂ capture process, heat capacity is one of crucial data used to calculate the sensible heat and heat duty for regeneration process and evaluate the effectiveness of CO₂ adsorbent. In this study, the heat capacities of aqueous MEA solution and various solid sorbents were measured at temperature ranging from 30 to 90 °C and results are shown in Figure 7. As shown in this figure, heat capacities of aqueous MEA 30% were higher than that of amine-impregnated PS. Since water in aqueous MEA was completely replaced by silica in MEA-PS, it is most likely due to the low heat capacity of silica, which results in reducing the heat capacities of amine-impregnated silica in comparison with aqueous amine. The results of this study indicated that the heat capacities of all amine impregnated PS increase with the increase of amine loading amount. The reason is due to the higher heat capacities of amine solvent and PEI, which caused the increase in the heat capacities of amine impregnated silica. Moreover, the heat capacities of both aqueous MEA and solid sorbent tend to increase as temperature increases from 30 to 90 °C. This is good agreement with the results of previous studies on the heat capacities of amine systems (Chiu, Liu et al. 1999; Shih, Chen et al. 2002). In a typical CO₂ adsorption process using aqueous amine, the sensible heat usually accounts for about 10—40% of the total regeneration heat (Abu-Zahra 2009; Yokoyama 2012) and it could be reduced by using sorbent with lower heat capacity. In this study, the impregnation of MEA onto PS (60%) reduced 42,68% in the heat capacity, while improving CO₂ adsorption capacity 199.5% compared to aqueous MEA 30%. As the results, the regeneration heat improved up to 89%. Obviously, the impregnation of amine onto helps significantly reduce the total regeneration heat.

Regeneration energy

CO₂ capture process is based on the reversible reaction between CO₂ and amine. The equilibrium of the reaction is shifted by the change in temperature. The most important parameters, affecting the performance and effectiveness of process, are the circulation rate and regeneration heat of sorbents. The former parameter can be determined by CO₂ adsorption capacity of adsorbent and CO₂ capture efficiency, while the later depends on the heat capacity, CO₂ adsorption heat of sorbent, and the latent heat of vaporization of volatile components in sorbent. In general, the total regeneration energy required for a CO₂ capture process can be determined by equation (6).

$$Q_{\text{reg}} = Q_{\text{des}} + Q_{\text{sen}} + Q_{\text{vap}} \quad (6)$$

Where, Q_{reg} is the regeneration energy of the process. Q_{des} is the heat of CO_2 desorption, which has the same absolute value as the heat of adsorption. Q_{sen} is sensible heat that must be supplied to increase temperature of sorbent to regeneration temperature. The sensible heat is calculated by the following equation:

$$Q_{sen} = C_p \cdot \Delta T \quad (7)$$

In which, C_p is heat capacity and ΔT is temperature difference between CO_2 rich adsorbent entering stripper and regeneration temperature.

Q_{vap} is the latent heat of vaporization of volatile components in sorbent, which usually includes the vaporization heat of water and amine. Q_{vap} is given as:

$$Q_{vap} = q_i \cdot m_i \quad (8)$$

Where, q_i and m_i are the specific heat of vaporization and the amount of volatile components (i), respectively. The heats of vaporization of MEA and DEA from adsorbents can be experimentally determined using TGA-DSC analyses.

In this study, to facilitate the calculation of regeneration energy, we considered the heat of desorption as a constant for each adsorbent. The average heat capacities were used to calculate the sensible heat. The temperature of sorbent entering stripper was fixed at 75 °C, while the regeneration temperature varied with different adsorbents. For CO_2 capture process using aqueous MEA, the operating conditions were estimated according to the simulation data from references (Han, Graves et al. 2011; Abu-Zahra, Jansens et al. 2012). The lean loading of MEA was 0.25 mole of CO_2 /mole of MEA, the molar ratio of H_2O/CO_2 in gas phase was 0.5, the regeneration temperature was 100 °C, and CO_2 capture efficiency was 90%. MEA has a low boiling point (170 °C), as impregnated onto PS, it is completely vaporized at 125 °C (Figure 4) with a vaporization heat of 0.60 kJ/g, which was determined by TGA-DSC analyses. Since MEA vaporized during desorption of CO_2 , the conventional operation mode of a fixed bed column is not suitable. Sun et al proposed a specific adsorption-desorption column for MEA impregnated TiO_2 (MEA- TiO_2), in which, the column includes 2 parts; bottom and top reactors. CO_2 and MEA generated from adsorbent in the bottom reactor are flowed into the top reactor containing TiO_2 and condenser, where MEA is trapped and CO_2 is flowed out of regeneration column (Sun, Fan et al. 2011). After each adsorption-desorption cycle, the position of the bottom and top reactors are switched for the next cycle. Their results indicated that about MEA- TiO_2 can be effectively regenerated at temperature from 90 to 110 °C. This adsorption column could be applied to volatile amine impregnated silica like MEA-PS and DEA-PS. We assume that the performance of MEA-PS is not much different with that of MEA- TiO_2 , so it can be regenerated at 90 °C. In the adsorption process

using volatile amine impregnated silica, the heat of vaporization of water can be negligible; however, the heat of vaporization of amine must be taken into account. To minimize the vaporization of DEA, we calculated the regeneration heat of DEA-PS at 100 °C. Regeneration temperature of PEI-PS was fixed at 110 °C. Cyclic CO₂ loadings of solid sorbents were 90% of their adsorption capacities.

Regeneration heat of aqueous MEA 30% and solid adsorbents are shown in Figure 8. Aqueous MEA has the highest regeneration heat, up to 3899 kJ/kg of CO₂. The regeneration heats of PEI-PS-50 and PEI-PS-60 are 2080 and 2109 kJ/kg of CO₂, respectively. For DEA-PS, as seen in Figure 4, DEA evaporated at temperatures ranging from 110 to 200 °C. We assume that 20% DEA in sorbents was vaporized during regeneration sorbent at 100 °C. Accordingly, the regeneration heats of DEA-PS calculated were 2544 and 2371 kJ/kg of CO₂ for PS impregnated 50 and 60% DEA, respectively. As shown in Figure 4, MEA evaporated at very low temperature and the evaporation completed at about 125 °C. Assuming that 50% MEA in sorbent is vaporized at the design regeneration temperature (90°C), the regeneration heats MEA-PS-50 and MEA-PS-60 are 2917 and 2866 kJ/kg of CO₂, respectively. However, it is difficult to minimize the vaporization of MEA at 50%, because MEA impregnated onto PS starts vaporize at low temperature (approximate 70 °C). In experiments conducted by Sun et al, 100% MEA in MEA-TiO₂ was vaporized at regeneration reactor (Sun, Fan et al. 2011). If the performance of MEA-PS in this study is similar to that of MEA-TiO₂, the regeneration heats of MEA-PS as 100% MEA vaporized are 3802 and 3728 kJ/kg of CO₂ for MEA-PS-50 and MEA-PS-60, respectively.

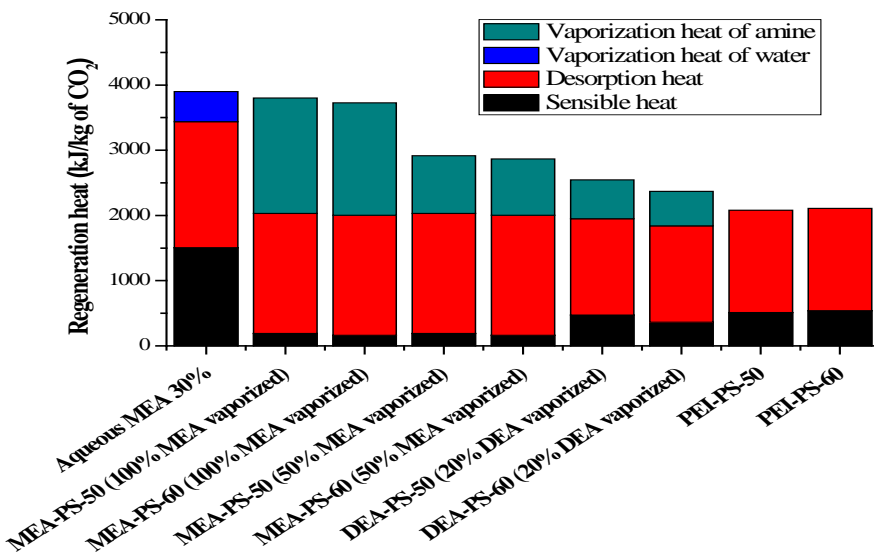

Figure 8. Regeneration heats of adsorbents

The obtained results indicated that the regeneration heat of aqueous MEA 30% was much higher than that of PEI-PS and DEA-PS. As presented in Figure 8, the high sensible heat and heat of vaporization of water are the main reason that accounts for the high regeneration heat of aqueous MEA 30%. The lower heat of CO₂ adsorption onto PEI-PS-50 helped reduce 18.8% of desorption heat, while the higher cyclic CO₂ adsorption capacity and lower heat capacity of PEI-PS-50 reduced sensible heat up to 66.0% in comparison with aqueous MEA 30%. Moreover, the use of PEI-PS avoided a significant amount of vaporization heat of water. Therefore, the total regeneration heat of CO₂ capture using PEI-PS-50 and PEI-PS-60 reduced 46.7% and 45.9%, respectively, in comparison with aqueous MEA 30%. Besides, that of CO₂ capture using DEA-PS-50 and DEA-PS-60 decreased 34.7% and 39.2% respectively. However, an effective reduction in regeneration energy can be attained only when impregnated amine has a relatively high vaporization temperature, so it is not vaporized during regeneration. In this study, as MEA was completely vaporized, the regeneration heat of MEA-PS-60 reduced only 4.4% compared to aqueous MEA 30%. As can be seen in Figure 8, desorption heat of MEA-PS is similar to that of aqueous MEA, but the sensible heat is relatively small; the sensible heat of MEA-PS-60 decreased 89.2% compared to aqueous MEA 30%. The heat of vaporization of water was avoided but it encountered a large amount heat of vaporization of MEA, which accounted for 46.2 % of the total regeneration heat. As the results, the regeneration heat of MEA-PS-60 reduced only 4.4% compared to aqueous MEA 30%.

Obviously, the vaporization heat of water and sensible heat account for the high regeneration energy of an aqueous amine. Therefore, to reduce the regeneration energy of a CO₂ capture process, the avoidance of vaporization heat of amine and water, the reduction in sensible heat and the enhancement in CO₂ adsorption capacity of sorbent should be taken into account. In view of this, PEI-PS is a great potential adsorbent for CO₂ capture process.

Conclusion

Precipitated silica has been synthesized and impregnated with different amines including AMP, MEA, DEA, and PEI. Generally, the adsorption capacity of silica was significantly improved by impregnation of amine. The thermal stability of adsorbent varied according to the vaporization temperature and thermal resistance of impregnated amine. The specific heat capacities and adsorption heats of amine impregnated PS were lower than that of aqueous MEA 30%. The calculation of regeneration heat indicated that prepared solid adsorbents require lower regeneration heat

compared to aqueous MEA 30%. The regeneration heat required for PEI-PS-50 was 2080 kJ/kg of CO₂; it is only 53.3% of the regeneration heat required for aqueous MEA 30%. However, as an amine with a low vaporization temperature such as MEA or AMP is used, the regeneration of amine usually accompanies with its vaporization, which requires more energy for the regeneration process. Thus, the regeneration heat required for MEA-PS reduced only 4.4% compared to that of aqueous MEA 30%.

Precipitated silica is an inexpensive material with high porosity, large surface area, and pore size which can be easily produced at a large scale. Therefore, it is a promising support material to produce solid adsorbent for CO₂ capture in view of cost and energy savings.

References:

- Abu-Zahra, M. (2009). "Carbon dioxide capture from flue gas: Development and evaluation of existing and novel process concepts." Delft University of Technology, The Netherlands.
- Abu-Zahra, M. R., P. J. Jansens, et al. (2012). "Experimental verification of Equilibrium-Stage and Rate-Based Simulations." *International journal of enhanced research in science technology and engineering* **1**(3).
- Abu-Zahra, M. R., L. H. Schneiders, et al. (2007). "CO₂ capture from power plants: Part I. A parametric study of the technical performance based on monoethanolamine." *International Journal of Greenhouse Gas Control* **1**(1): 37-46.
- Abu-Zahra, M. R. M., J. P. M. Niederer, et al. (2007). "CO₂ capture from power plants. Part II. A parametric study of the economical performance based on mono-ethanolamine." *International Journal of Greenhouse Gas Control* **1**(2): 135-142.
- Artanto, Y., J. Jansen, et al. (2012). "Performance of MEA and amine-blends in the CSIRO PCC pilot plant at Loy Yang Power in Australia." *Fuel* **101**(0): 264-275.
- Carson, J. K., K. N. Marsh, et al. (2000). "Enthalpy of solution of carbon dioxide in (water + monoethanolamine, or diethanolamine, or N-methyldiethanolamine) and (water + monoethanolamine + N-methyldiethanolamine) at T 298.15 K." *The Journal of Chemical Thermodynamics* **32**(9): 1285-1296.
- Chen, C., S.-T. Yang, et al. (2009). "Amine-impregnated silica monolith with a hierarchical pore structure: enhancement of CO₂ capture capacity." *Chemical Communications*(24): 3627-3629.
- Chiu, L.-F., H.-F. Liu, et al. (1999). "Heat Capacity of Alkanolamines by Differential Scanning Calorimetry." *Journal of Chemical & Engineering Data* **44**(3): 631-636.

- Chung, T. S., D. Patiño-Echeverri, et al. (2011). "Expert assessments of retrofitting coal-fired power plants with carbon dioxide capture technologies." *Energy Policy* **39**(9): 5609-5620.
- da Silva, E. F. and H. F. Svendsen (2005). "Study of the Carbamate Stability of Amines Using ab Initio Methods and Free-Energy Perturbations." *Industrial & Engineering Chemistry Research* **45**(8): 2497-2504.
- Ebner, A. D., M. L. Gray, et al. (2011). "Suitability of a Solid Amine Sorbent for CO₂ Capture by Pressure Swing Adsorption." *Industrial & Engineering Chemistry Research* **50**(9): 5634-5641.
- EPA (2013).
"<http://www.epa.gov/climatechange/ghgemissions/gases/co2.html> cited 10/03/2013."
- Feron, P., M. Abu-Zahra, et al. (2007). "Development of post-combustion capture of CO₂ within the CASTOR Integrated Project: Results from the pilot plant operation using MEA." 3th International Conference on Clean Coal Technologies for our Futur, Cagliari, Italy.
- Filburn, T., J. J. Helble, et al. (2005). "Development of Supported Ethanolamines and Modified Ethanolamines for CO₂ Capture." *Industrial & Engineering Chemistry Research* **44**(5): 1542-1546.
- FutureGen (2011).
"<http://www.futuregenalliance.org/pdf/FutureGenFacts.pdf> cited 10/03/2013."
- Geisbrecht, R. and P. Dipietro (2009). "Evaluating options for US coal fired power plants in the face of uncertainties and greenhouse gas caps: The economics of refurbishing, retrofitting, and repowering." *Energy Procedia* **1**(1): 4347-4354.
- Han, C., K. Graves, et al. (2011). "Simulation of the Energy Consumption of CO₂ Capture by Aqueous Monoethanolamine in Pilot Plant." *Energy and Environment Research* **1**(1): 67-80.
- Ichikawa, S., T. Seki, et al. (2010). "Amorphous nano-structured silicas for high-performance carbon dioxide confinement." *Journal of Materials Chemistry* **20**(16): 3163-3165.
- Idem, R., M. Wilson, et al. (2005). "Pilot Plant Studies of the CO₂ Capture Performance of Aqueous MEA and Mixed MEA/MDEA Solvents at the University of Regina CO₂ Capture Technology Development Plant and the Boundary Dam CO₂ Capture Demonstration Plant." *Industrial & Engineering Chemistry Research* **45**(8): 2414-2420.
- IPCC (2005). "IPCC Special report: Carbon Capture and Storage."
- Kim, I. and H. F. Svendsen (2007). "Heat of Absorption of Carbon Dioxide (CO₂) in Monoethanolamine (MEA) and 2-(Aminoethyl)ethanolamine (AEEA) Solutions." *Industrial & Engineering Chemistry Research* **46**(17): 5803-5809.

- Knowles, G. P., J. V. Graham, et al. (2005). "Aminopropyl-functionalized mesoporous silicas as CO₂ adsorbents." *Fuel Processing Technology* 86(14–15): 1435-1448.
- Kohl, A. and R. Nielsen, Eds. (2011). *Gas purification*, Gulf Publishing Company.
- Lee, B., D. Kim, et al. (2009). "A comparative study on the carbon dioxide capture power between 30 wt% 2-amino-2-methyl-1-propanol and 30 wt% methyldiethanol amine aqueous solutions." *Korean Journal of Chemical Engineering* 26(3): 818-823.
- Lowell, S., J. E. Shields, et al., Eds. (2004). *Characterization of porous solids and powders: Surface area, pore size and density*. Dordrecht, Kluwer Academic Publishers.
- Maiti, A., W. L. Bourcier, et al. (2011). "Atomistic modeling of CO₂ capture in primary and tertiary amines – Heat of absorption and density changes." *Chemical Physics Letters* 509(1–3): 25-28.
- Maththias, F. (2010). "Cost and Performance of Carbon Dioxide Capture from Powder Generation." *International Energy Agency*.
- MLO (2013). "<http://www.esrl.noaa.gov/gmd/obop/mlo/> cited 10/03/2013."
- Mondal, M. K., H. K. Balsora, et al. (2012). "Progress and trends in CO₂ capture/separation technologies: A review." *Energy* 46(1): 431-441.
- Quang, D. V., J. K. Kim, et al. (2012). "Effect of the gelation on the properties of precipitated silica powder produced by acidizing sodium silicate solution at the pilot scale." *Chemical Engineering Journal*.
- Quang, D. V., P. B. Sarawade, et al. (2011). "Facile route for preparation of silver nanoparticle-coated precipitated silica." *Applied Surface Science* 257(9): 4250-4256.
- Reynolds, A. J., T. V. Verheyen, et al. (2012). "Towards Commercial Scale Postcombustion Capture of CO₂ with Monoethanolamine Solvent: Key Considerations for Solvent Management and Environmental Impacts." *Environmental Science & Technology* 46(7): 3643-3654.
- Rochelle, G., E. Chen, et al. (2011). "Aqueous piperazine as the new standard for CO₂ capture technology." *Chemical Engineering Journal* 171(3): 725-733.
- Samanta, A., A. Zhao, et al. (2011). "Post-Combustion CO₂ Capture Using Solid Sorbents: A Review." *Industrial & Engineering Chemistry Research* 51(4): 1438-1463.
- Sarawade, P. B., J. K. Kim, et al. (2011). "Effect of drying technique on the physicochemical properties of sodium silicate-based mesoporous precipitated silica." *Applied Surface Science* 258(2): 955-961.

- Shih, T.-W., Y.-J. Chen, et al. (2002). "Heat capacity of aqueous mixtures of monoethanolamine with 2-piperidineethanol." *Thermochimica Acta* 389(1–2): 33-41.
- Sun, Z., M. Fan, et al. (2011). "Desorption Kinetics of the Monoethanolamine/Macroporous TiO₂-Based CO₂ Separation Process." *Energy & Fuels* 25(7): 2988-2996.
- Sun, Z., M. Fan, et al. (2011). "Supported Monoethanolamine for CO₂ Separation." *Industrial & Engineering Chemistry Research* 50(19): 11343-11349.
- UNEP (2013). "<http://www.unep.org/climatechange/Portals/5/documents/June.pdf> cited 10/03/2013."
- Wang, M., A. Lawal, et al. (2011). "Post-combustion CO₂ capture with chemical absorption: A state-of-the-art review." *Chemical Engineering Research and Design* 89(9): 1609-1624.
- Wilson, E. and D. Gerard, Eds. (2007). *Carbon capture and sequestration :integrating technology, monitoring and regulation*. Oxford, UK, Blackwell Publication.
- Xie, H.-B., Y. Zhou, et al. (2010). "Reaction Mechanism of Monoethanolamine with CO₂ in Aqueous Solution from Molecular Modeling." *The Journal of Physical Chemistry A* 114(43): 11844-11852.
- Xu, X., C. Song, et al. (2002). "Novel Polyethylenimine-Modified Mesoporous Molecular Sieve of MCM-41 Type as High-Capacity Adsorbent for CO₂ Capture." *Energy & Fuels* 16(6): 1463-1469.
- Yokoyama, T. (2012). "Analysis of reboiler heat duty in MEA process for CO₂ capture using equilibrium-staged model." *Separation and Purification Technology* 94(0): 97-103.
- Zhao, Y., Y. Shen, et al. (2012). "Effect of chemical modification on carbon dioxide adsorption property of mesoporous silica." *Journal of Colloid and Interface Science* 379(1): 94-100.