

Proceedings of International Conference

"Internationalization of Islamic Higher Education Institutions Toward Global Competitiveness"

Semarang, Indonesia – September 20th - 21th, 2018**Paper No. B-32**

Control System Design in Production Machines Paving Block Made from Plastic Waste

M. Hariansyah¹, Abdul Karim Halim²

Ibn Khaldun University, Department of Electrical Engineering

Jl. KH. Sholeh Iskandar KM 2 Bogor Jawa Barat Indonesia

m.hariansyah68@gmail.com;

Abstract - Garbage has not been handled properly, even waste is a national problem. Campus Ibn Khaldun University of Bogor in 2016 recorded as much as 12 m³ / day, resulting from canteen trash and office waste. Trash consists of type, organic and inorganic. This type of inorganic waste takes up to 450 years to break down naturally. Trash is considered as a source of diseases and disasters, such as air pollution, water, the environment until the occurrence of landslides caused by piles of garbage. One effort to overcome the waste of anorganic (plastic bag crackle) is to create a production machine that can change the form of waste into paving blocks. The objectives and usefulness of the research are (a) to produce control system design in production machine to manage plastic waste into paving block, (b) obtain plastic heating time response in tube and response time of pressure in tube. The method is done by planning the form of technology and system control applied. as well as production machine capacity. The process control system uses temperature sensors and pressure sensors that can convert analog signals into digital 4-20 mA and forwarded to PLC (Program Logic Control). Temperature inside tube at setting 200 oC, and Pressure 2 bar. If the temperature setpoint $T > 200$ oC, then the PLC will order the relay to stop the supply voltage through the contactor. So also with pressure if set point $P > 2$ bar then control valve immediately opened until pressure in tube remain stable. The result of the design of high-heating tube of 50 cm, diameter 30 cm capable of producing 1 kg plastic produce 2 units of paving block (5x10x25) cm, with compressive strength reach 235 kg / cm²

Keywords: Control System, Production Machine, Paving Block, Plastic Waste

1. INTRODUCTION

1.1 Background Problems

The volume of garbage in the Ibn Khaldun University Campus Bogor in 2016 was recorded at 12 m³ / day, generated from Household Waste (SRT) and Waste from the office, (M. Hariansyah, Achyar Eldine, 2016). Garbage consists of types, organic and inorganic. This type of organic waste can be decomposed naturally, while inorganic waste is very difficult to decompose naturally, requiring up to 450 years, (Basrianto, 2017). To this day the waste is disposed of to the Final Disposal Site (TPA), so that waste becomes a problem as a source of diseases and calamities, such as air, water, environmental pollution and landslides due to mountainous landfill. One of the efforts to tackle organic waste (crackle plastic bags) is to create a production machine that can change the form of waste into paving blocks. The aims and benefits of the research that are to be obtained are (a) producing a production machine prototype to manage pressure in savings. The benefits of the research to be achieved are, (a) making the UIKA Bogor campus as a pilot project in terms of handling the problem of plastic waste coming from the UIKA Bogor canteen, (b) machines can be mass produced, and can be marketed to consumers. used on the aforementioned background, it can be formulated, that organic waste is a national problem, so it needs to be solved

by breaking down the form of plastic waste into paving blocks by building waste management machine technology.

1.2 Definition of Waste

Waste is material that has no value or is not valuable that is wasted or disposed of from sources of human activity or natural processes that do not have economic value, (Basrianto, 2017). Garbage is divided into several types, namely organic and inorganic. Organic waste consists of plants and animal waste taken from nature or produced from agricultural, fishery or community activities such as vegetable waste and others, and is easily broken down in natural processes. Inorganic waste comes from non-renewable natural resources such as minerals and petroleum, or from industrial processes. Some organic waste materials are not found in nature such as plastic and aluminum. Some inorganic substances as a whole cannot be broken down by nature, while others can only be described in a very long time. Examples of inorganic waste such as bottles, plastic bags. So that efforts are needed to reduce inorganic waste by doing waste management.

Waste management is part of waste management and according to (Law No. 18 of 2008), it is defined as the process of changing the form of waste by changing the characteristics, composition, and amount of waste. Waste management is an activity that is intended to reduce the amount of waste, in addition to utilizing the value that is still contained in waste can be done in the form of composting, recycling, incineration and others, (Hadiwijoto, S, 2012)

1.3 Types of Garbage

Solid waste can generally be divided into two parts, namely organic waste and inorganic waste. Organic waste (commonly called wet waste) and inorganic waste (dry waste). Organic waste consists of ingredients that make up plants and animals taken from nature or produced from agricultural, fishery or other activities. This waste is easily described in natural processes. Household waste is mostly organic material, for example waste from the kitchen, leftover flour, vegetables etc.

Inorganic waste comes from non-renewable natural resources such as minerals and petroleum, or from industrial processes. Some of these ingredients are not available in nature such as plastic and aluminum. Some inorganic substances as a whole cannot be broken down by nature, while others can only be described in a very long time. This type of garbage at the household level, for example in the form of bottles, plastic bags, and can bottles, paper, newspapers, and cartons is an exception. Based on provenance, paper, newspapers and cartons include organic waste. But because paper, newspapers and cartons can be recycled like other inorganic waste (for example glass, cans, and plastic), they are put into inorganic waste groups.

Inorganic waste comes from non-renewable natural resources such as minerals and petroleum, or from industrial processes. Some of the organic waste materials are not found in nature such as plastic and aluminum. Some inorganic substances as a whole cannot be broken down by nature, while others can only be described in a very long time. Examples of inorganic waste such as plastic bottles, plastic bags. So that efforts are needed to reduce inorganic waste by doing waste management.

1.4 Waste Management

Waste management is part of waste management and according to Law No. 18 of 2008, is defined as the process of changing the form of waste by changing the characteristics, composition, and amount of waste, [3]. Waste management is an activity that is intended to reduce the amount of waste, besides utilizing the value that is still contained in waste can be done in the form of composting, recycling, incineration and others. This type of waste burning can be divided into several parts, (Hadiwijoto, S, 2012)

Stoichiometric combustion, which is combustion carried out with an oxygen supply that is in accordance with the need for complete combustion.

- a. Excessive combustion of air, ie combustion carried out with an air supply that exceeds the need for complete combustion
- b. Gasification, which is a partial combustion process in substoichiometric conditions where the products are CO (Carbon Oxide), H₂ (Hydrogen Gas) and H₂C (Hydrocarbon Gases)
- c. Pyrolysis, which is a combustion process without air supply.

Organic waste that is processed properly and correctly can produce briquettes as raw materials to produce energy, compost as a source of fertilizer for plants. While inorganic waste can be made into souvenirs as merchandise, and as a paving block.

Based on provenance, paper, newspapers and cartons include organic waste. But because paper, newspapers and cartons can be recycled like other inorganic waste (for example glass, cans, and plastic), they are put into inorganic waste groups. Inorganic waste comes from non-renewable natural resources such as minerals and petroleum, or from industrial processes. Some of the organic waste materials are not found in nature such as plastic and aluminum. Some inorganic substances as a whole cannot be broken down by nature, while others can only be described in a very long time. Examples of inorganic waste such as plastic bottles, plastic bags. So that efforts are needed to reduce inorganic waste by doing waste management.

1.5 Main Raw for Making Paving Blocks.

Research on the manufacture of paving blocks from raw materials for plastic bag waste has been carried out, (M, Hariansyah, 2016). The process of making paving blocks in a conventional way, plastic waste is first cleaned, then put in a heating tube, and heated with a gas stove, to a temperature of 150 °C, until the plastic melts, then transferred into a paving block mold measuring 25 cm long, 10 cm wide and 4 cm thick, and left to freeze. The results of the paving block press test reached K 325 hardness. The plastic bag cracked using the main raw material of HDPE (High Density Polyethylene). HDPE is the result of polymerization of ethylene which has a density of 0.940 or greater, including homo and co-polymer with larger α olefins. The product uses 100% pure, or the recycle aval mixture depends on the quality and needs. The plastic bag waste is Polyethylene consisting of various types. Polyethylene is basically a thermoplastic resin obtained by polymerizing ethylene gas (C₂H₄). Polymers with low molecular levels are liquids that are widely used as lubricating fluids, while polymers with medium molecular level are waxes which include paraffin. Polymers with high molecular levels are materials that are widely used in the plastics industry

1.6 Waste Management Technology

Waste management technologies such as Bio Digester, Piroliser, Composter, Gasifier [6], in various configurations provide evidence for effectiveness and efficiency as well as achieving a clean development mechanism for CDM (Clean Development Mechanism) management of waste, waste and biomass. to become electric power through gasification technology to produce H₂ fuel and CO. The kinds of technology used in waste management from are, (Bactiar,dkk, 2012).

a. Bio Digister

Bio Digeter biogas generation techniques in airtight digestion reactors (dry and wet methods) with the help of microbes as an activator for methane generation, have proven effective in resolving easily degradable and perishable materials. Examples of waste such as food scraps, waste and fresh biomass in urban areas, garden weeds, aquatic weeds, agricultural product processing residues and crop residues from agriculture, plantations, fisheries, livestock and forestry.

b. Pirolizer.

Pyrolyzer tools for the running of thermo pyrolysis chemical techniques convert solid matter into a gas phase through the chemical decomposition process of organic matter by heating without or little oxygen or other reagents, where the raw material will experience a breakdown of the chemical structure into a gas phase, then condensation will become a liquid phase (oil).

c. Composter.

The tool composer in the decomposition process is assisted by (activator) microbes that break down plant matter, water and the presence of oxygen (aeration) which is appropriate to regularly convert organic matter into solid liquid and compost.

d. Gasifier.

Gasifier is a tool that carries out the gasification process, which is a process that converts organic or fossil fuels based on carbon materials into carbon monoxide (CO), hydrogen (H₂) and carbon dioxide (CO₂). This is achieved by reacting the material at high temperatures (700 ° C), without combustion, with a controlled amount of oxygen and / or steam. The choice of the gasification process output can be utilized depending on the need, producing Syn Gas fuel for the generator or heat generator (burner). With the second combustion of Syn Gas (H₂, CO) carried out in the reactor will produce high heat for the pyrolysis reaction.

1.7 Control System.

Planning the production machine, which is made automatically there are at least two that must be considered, namely temperature and pressure, (M. Budiarto, A. Wijaya,2013). The use of thermocouples to produce heat sources needs to be adjusted to the material requirements that will be applied. Likewise with pressure. To detect temperature and pressure can be done with a thermocouple that is attached with a transmitter that can convert the signal heat into an amperage or voltage electrical signal, as well as a transmitter procedure. Some of the equipment that needs to be equipped are Analog Digital, PLC and digital analyzers, which are required in the control system, (Mistsubishi, 2013)

2. RESEARCH METHOD

The research method is described as follows:

2.1 Time and Place of Research

The time and place of research is conducted from September 2017 to April 2018. Located at the Laboratory of Electric Power Engineering Conversion and Control System of the Electrical Engineering, Faculty of Engineering, Ibn Khaldun University in Bogor, Jl. KH. Sholeh Iskandar KM 2 Bogor.

2.2 Research Materials and Tools

The materials and research tools used for the study are shown in Table 1 below.

Table 1. Research Materials and Tools

No	Material and research tools	Volume	Units	No	Material and research tools	Volume	Unit
1.	Heating tube and table making			2.	Purchase of heating devices and control systems		
	a. Stenliss plate 120x242x0,8	2	sheet		a. Heater 220 V, 1000W	1	set
	b. Light steel 1 mmx 70 mmx6m	5	stem		b. Heater isolation 5 cm x60 cm x 120cm	2	lembar
	c. Screw steel	1	box		c. Pressure control 0 -10 bar	1	unit
	d. Gurinda Stone 100 cm	5	unit		d. Control Temperature	1	set
	e. Stenliss plate 0x242x1,2mm	1	sheetr		e. Thermokopel 500oC, 4-20 mA	1	set
					f. Control Panel box 30x40x22	1	unir
3.	Control Panel Creation			4	The tools used:		
	a. PLC Omron Type ZAEN 20C1 DR	1	unit		a. Electrical welding machine 1 kW, 380 V, 50 Hz	1	set
	b. Control Cable program	1	set		b. Cutting machine,	1	set
	c. Contactor 380/220 V AC	1	unit		c. Tools	1	set
	d. Relay 24 V DC	1	unit		d. Cat saw	1	set
	e. TOR, 10 A, 380, 50 Hz	1	unit		e. Drill machine		
	f. MCB 4 A, 220V Scheneder	1	unit		f. Hacksaw		
	g. Phasa Light RST	3	unit		g. Sandpaper		
	h. Alaram	1	unit		h. Paint and brush		
	j. Instalation cable program, 0,75 mm2	50	rol				
	k. D Cable uck 40x60 mm	25	meter				

2.3 Work Procedure

The complete work order is shown in Figure 2 below

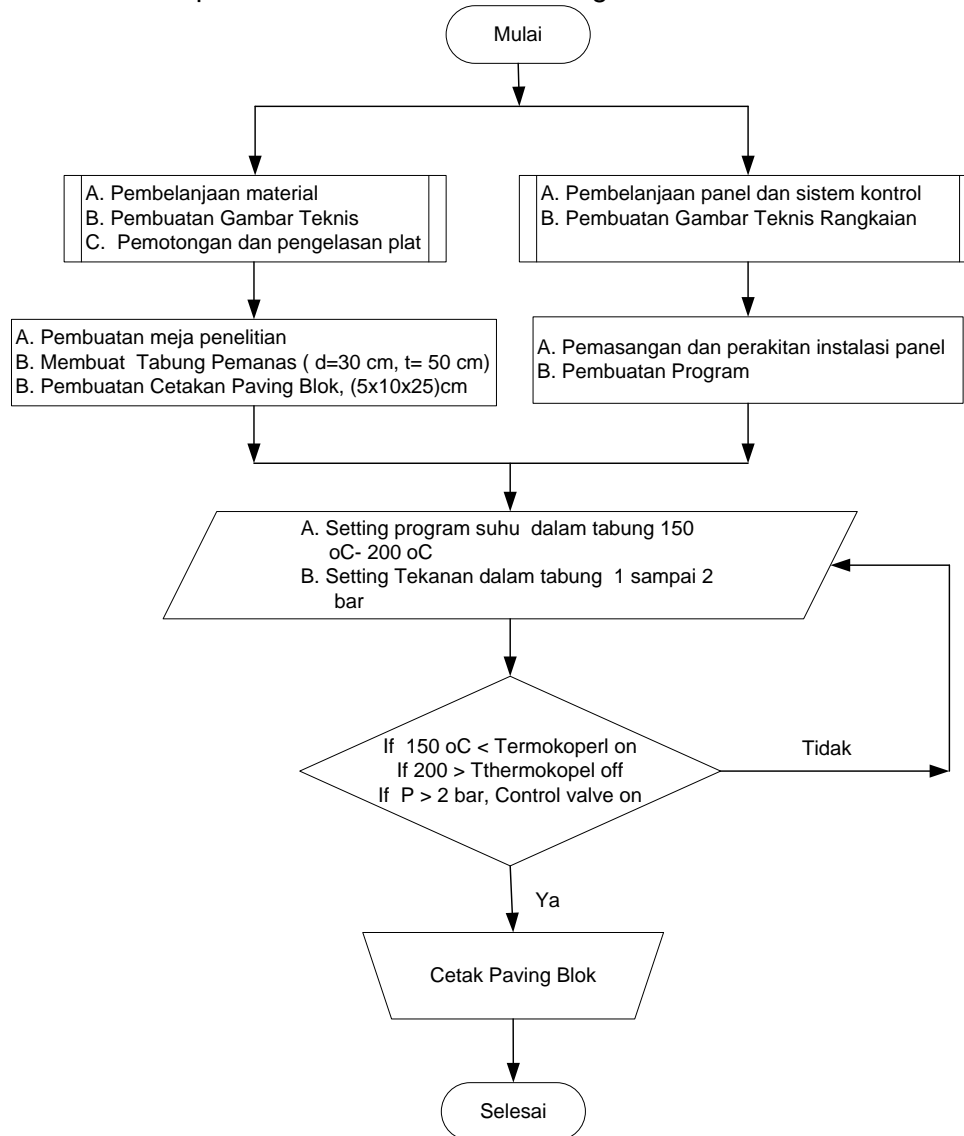

Figure 2. Research Flow Chart

2.4 Production Process of Paving Block Machine

Before processing the production of paving block machines, first plan the technical drawings and the size of the tubes to be made, as well as the materials to be used. The shape of the image created is shown in Figure 3 below. The heater is made in the form of a tube, and the bottom of the tube is made of cone which is connected to pipe 2 ", and the end of the pipe is given a valve. The material for making a heating tube uses a 1.0 mm thick Stenlis plate, and a tube size of 30 cm diameter, 50 cm tube height. So that the tube does not move, the side of the tube is flanked by a table with a size of 3x3 cm iron plate, rectangular in shape. The tube wall consists of 2 layers, the first layer is a heater 1,000 watt. Then it is wrapped in a 5 cm thick drum, as heating insulation. The second layer

is fitted with a stainless steel plate with a thickness of 1.2 mm which serves to isolate heat from the inside of the operator's skin and safety tube if touched by the heating tube.

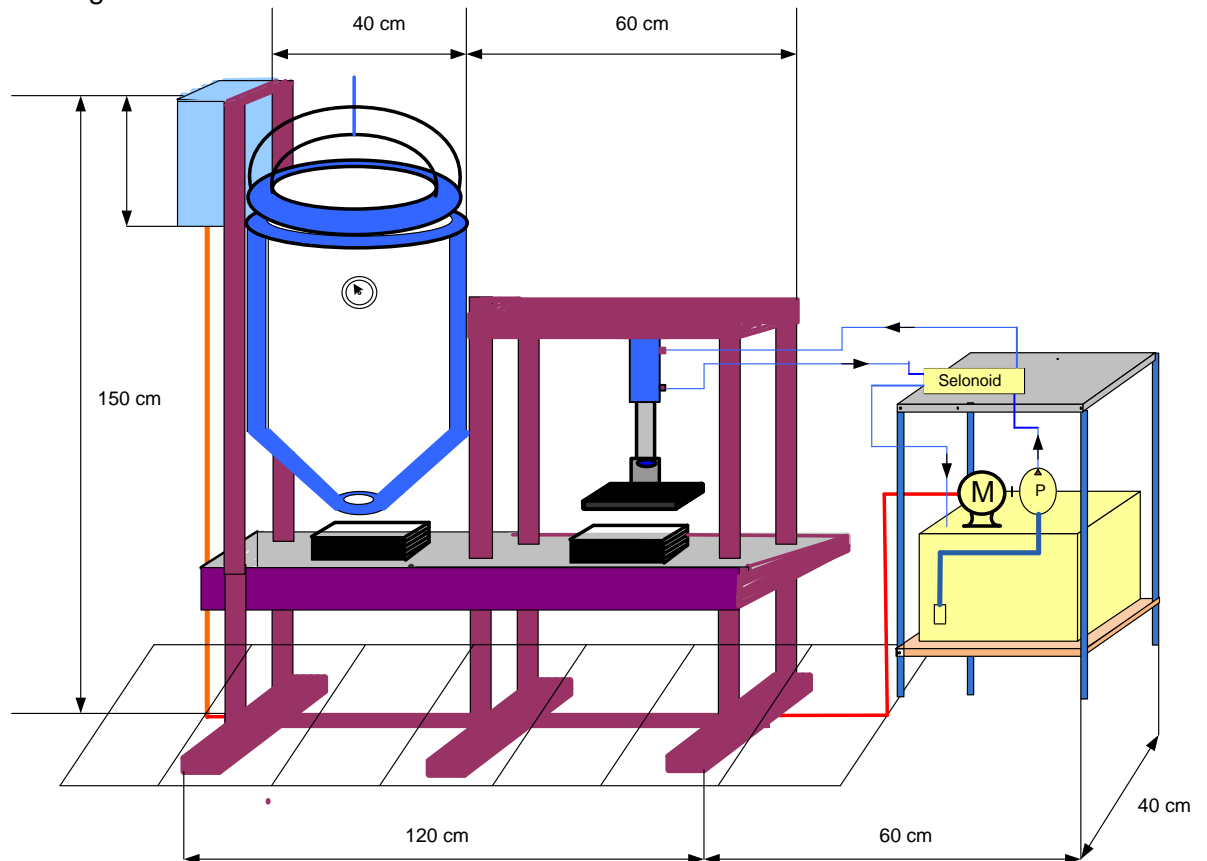

Figure 3. Heating Tube Production Equipment for making Paving blocks

2.5 Paving Block Printing

The process of producing plastic waste into paving blocks begins with garbage collection that is done manually, sorted and cleaned, then stored in a warehouse, which will be used as raw material for making paving blocks. Garbage that has been sorted and cleaned and put into a pineapple tube. The temperature was obtained through a 1,000 watt capacity heater, 220 V of electricity, at a frequency of 50 Hz. The required temperature is 200 °C, controlled by a thermocouple sensor, through a current magnitude of 4-20 mA connected to the PLC (Program Logic Controller), to make the plastic melt. Plastic melt is put into a mold that is sized (5 x10x25) cm, until the mold surface is fully filled, then manually moved to press. The pressure is given 1 bar, for 3 seconds.

2.6 Making Control System Programs

Programming control systems are carried out to maintain the pressure and temperature in the heating tank. As a temperature controller the thermostat 500 °C is used, and it is set between 150 °C to 200 °C, and as a pressure controller the transmitter pressure gate 10 bar is used. If the set point of the predetermined

temperature exceeds 200 oC, the control system will instruct the power supply of the voltage to be cut off, so that the heater at the heater is reduced, after the temperature drops to the lower limit of the 150 o C set point, the system will command power supply immediately on. The same thing if the pressure is more then the pressure valve will open until the pressure inside the tank is normal again. Integration of the control system is done using a PLC (Program Logic Controller)

3. RESULTS AND DISCUSSION

3.1 Results of Paving Block production machines

The results of the paving block production machine are shown in Figure 4 below.



Figure 4. Results of paving block production machines

Based on Figure 4 the above shows the shape of the production machine, consisting of a heating tube, control panel system and (hydraulic press machine plan), which is incorporated in one research table. The study table size is 120 cm long, 50 cm wide and 60 cm high. table legs made of iron size (4x4) cm and table base using iron plate with a thickness of 1.2 mm. The heating tube is 50 cm high, and 30 cm in diameter, the tube capacity is able to load 1 kg of plastic, stored on a research table flanked by two iron poles, used to hold the tube from moving or shifting, making it easier for the production process. At the research desk, a control system panel is also installed, to make it easier to conduct research and measurement.

3.2 Production Results of Paving Blocks

The results of the paving block production process are shown in Figure 5 below.



Figure 5. The process of making paving blocks and printing results of Paving blocks

Based on Figure 5 above, the production process begins with inserting plastic waste into a heating tube as much as 1 kg (until all heating tubes) are fully filled. Then the electricity is inserted to supply the voltage and electric current to the heater. The process of transferring heat from the heater to the heating tube chamber takes 50 minutes, to reach 200 oC, and the plastic will melt after 60 minutes. The next step is to open the heating tube faucet located at the bottom side of the tube, and the plastic liquid is transferred into the paving block mold until all the paving block mold surfaces are met, then press and cool. Production results in the form of paving blocks from plastic waste materials, have a size (5x10x25) cm, and one paving block unit has a weight of 0.5 kg. The second production process is carried out in the same way, but the plastic melting process takes 15 minutes, because the heating tube has reached a maximum temperature of 200 oC, so there is no preheating process.

3.3 Testing response time Temperature of empty tube conditions

Testing the temperature response time is done on the heater and in the heating tube in the case of the heater tank is still empty. The method of measurement and measurement results are shown in Figure 6 below

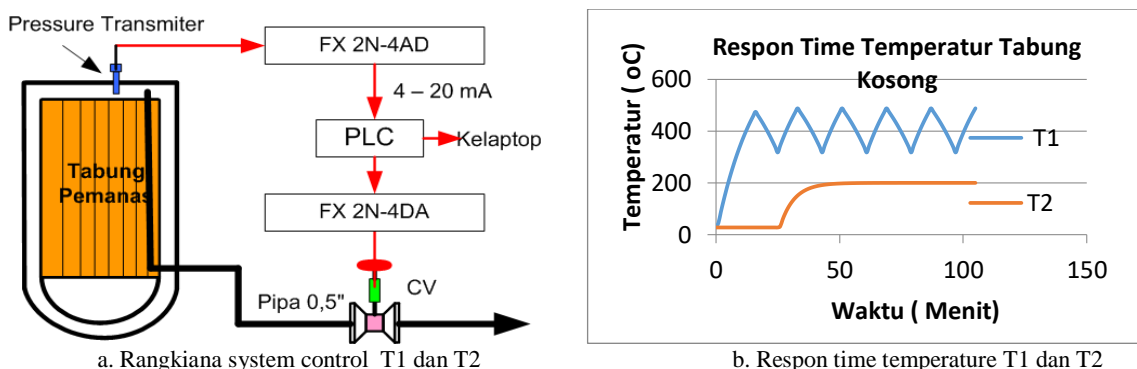

Figure 6. Temperature measurement range and time temperature response on the heater and inside the heating tube

Based on Figure 6 section (a), it can be seen that two thermocouple sensors are installed in two different places. T1 is installed to measure temperature on the heater and T2 is used to measure the temperature in the tube. The results of temperature sensor readings T1 and T2 sent to FX 2N-4AD TC in the form of a current (4-20 mA) then processed to the PLC. PLC can provide temperature

measurement data to a laptop and can also give orders to FX2N-4DA to instruct the relay to insert the contactor, so that the supply of electrical power entering the heater is interrupted, if the heater temperature setting ($300\text{ oC} < T1 < 490\text{ oC}$) and set temperature in the tube ($150\text{ oC} < T2 < 200\text{ oC}$).

In Figure 6 section (b), there is a response to the temperature time on the heater (T1) and inside the heater tube (T2). When the heater (T1) gets power supply the temperature rises hyperbolic, and takes 25 minutes to reach a temperature of $490\text{ }^\circ\text{C}$, when the setting points are reached the contactor will stop supplying electrical power, so the temperature decreases at T1, after reaching the lowest T1 setting in 300 oC , the PLC instructs the relay to activate the contactor again, so that the heating process is repeated, and continues. The time needed to reduce the temperature at T1 from 490 oC to 300 oC , for 10 minutes. Still in Figure 6 section (b), the response time at the temperature in the tube (T2), starting from 0 minutes to 30 minutes is still at a temperature of 28 oC , the temperature in the tube starts to rise hyperbolically entering the 30 minutes, heat transfer process occurs. from the heater (T1) to the heating tube (T2). T1 and T2 are programmed with each other if the temperature at T1 drops then T2 is also expected to fall, but in response time the T2 temperature stays at 200 oC , this is because the heat transfer process in an isolated tube responds longer to heat transfer.

3.4 Response time testing Temperature Condition of Tubes Containing

Testing the temperature response time is done on the heater and in the heating tube in the case of the tank the heater is filled with plastic. Plastic that is inserted into a heating tube weighing 1 kg consists of various types of plastic. The measurement method and measurement results are the same as shown in Figure 6 above, and the response time of the temperature transfer from the heater to the heating tube is shown in Figure 7 below.

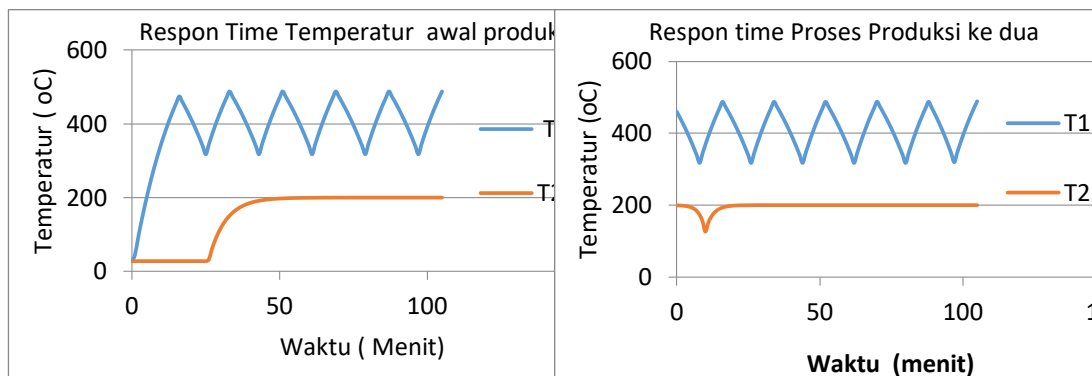

(a) Respon time awal produksi paving blok (b) Respon time proses produksi paving blok kedua

Figure 7. Material of plastic waste and respond time T1 and T2 when heating Plastic waste

Based on Figure 7 above part (a), there is a response to the temperature time on the heater (T1) and inside the heater tube (T2). When the heater (T1) gets power supply the temperature rises hyperbolic, and takes 25 minutes to reach a temperature of $490\text{ }^\circ\text{C}$, when the setting points are reached the contactor will stop supplying electrical power, so the temperature decreases at T1, after reaching the lowest T1 setting in 300 oC , the PLC instructs the relay to

activate the contactor again, so that the heating process is repeated, and continues. The time needed to reduce the temperature at T1 from 490 oC to 300 oC, for 10 minutes. Response time at the temperature in the tube (T2), starting from 0 minutes to 25 minutes still at a temperature of 28 oC, the temperature inside the tube began to rise hyperpolically entering the 25 minute time, the process of transferring heat from the heater (T1) into the heating tube occurred. (T2). T1 and T2 are programmed with each other if the temperature at T1 drops then T2 is also expected to fall, but in response time the T2 temperature stays at 200 oC, this is because the heat transfer process in an isolated tube responds longer to heat transfer. The time used to complete the plastic melting process for 70 minutes, and removed from the tube through a 2 "valve. Based on Figure 7 above part (b), namely the second thermal heating production process. The temperature in T1 appears to decrease from 490 to 300. This happens because of a program that has been set for T1 in the PLC. At T2, the temperature drops from 200 oC to 130 oC, this is in line with the opening of the tube cap and when inserting plastic waste into the tube. The time needed to put 1 kg of garbage into the tube takes 1 minute, when the tube cap is closed again the temperature in the tube rises again as before. The time needed to melt plastic waste in a tube for 20 minutes.

3.5 Response to Time Pressure in a Heating Tube

Testing the time pressure response in a heating tube in a state of the tube is still empty and already contained. The measurement method and time pressure response are shown in Figure 8 below.

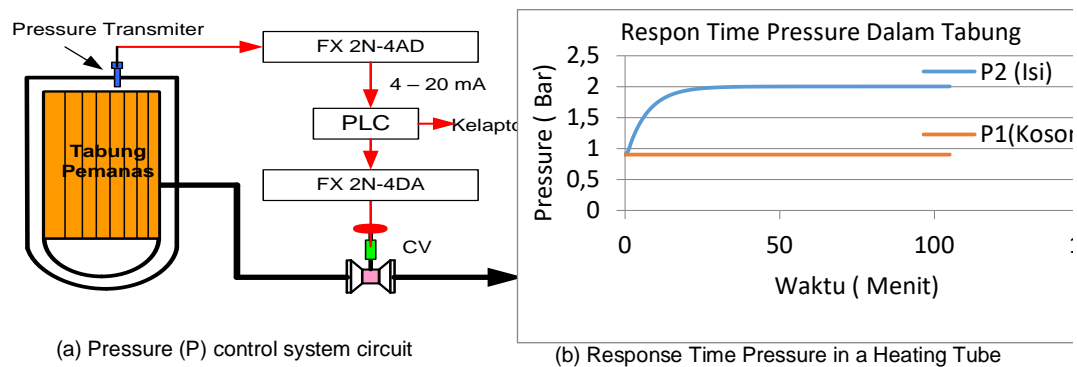

Figure 8. Pressure control system circuit and response time pressure in a heating tube

Based on Figure 8 section (a) it is shown that the heating tube is equipped with a pressure transmitter, which can change the pressure to an electric current signal (4-20) mA. The signal is forwarded to FX 2N-AD and then forwarded to the PLC. In the PLC programming has been done if $(2 > P)$ bar, then the CV will open several%, until the pressure inside the tube is released proportionally and the pressure in the tube remains stable, ie 2 bars. In Figure 9, part (b) shows the time pressure response in the heating tube, when the tube is still empty (P1), the pressure remains stable at 0.8 bar, up to 100 minutes, there is no added pressure in the tube. When the tube is filled, the plastic waste time pressure

response appears to increase parabolically. At 20 minutes, the pressure starts at 2 bars. This is due to the occurrence of heating processes on the raw material of waste in the tube, causing the temperature to rise slowly.

3.6 Response Time Control Valve (CV)

The response time CV when used to open and close the valve, which serves to remove more pressure in the tank, is shown in Figure 10 below

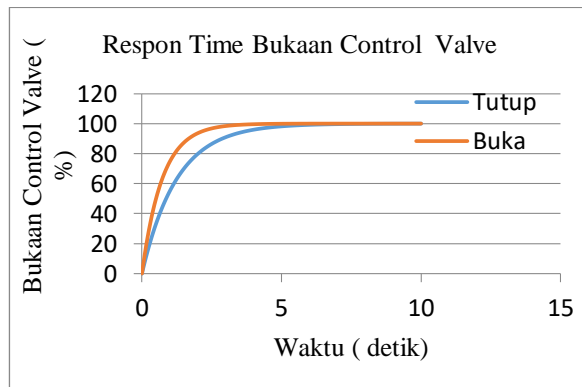

Figure 10. Response Time Valve Control

Based on Figure 10, the CV response time when opening and closing the valve can take 7 seconds. When going to open the valve response time the opening is faster than closing, especially occurs at openings 25% to 95%, this is due to a delay in the PLC when it will give orders to FX2N-4DA, so the CV motor, too late to respond. During the production process, the valve opening paving blocks are used between 0% and 10%, which takes 2 seconds. This is consistent with the need to keep the temperature and pressure in the tube constant.

3.7 Press Strength Testing Paving Blocks

Paving block compressive strength testing is carried out to determine the strength of the block paving when it gets a load from above. The test is carried out by applying hydraulic pressure. Starting from the lowest to the highest pressure. Test results of the average compressive strength of the 10 simple units tested were 230kg / cm².

4. CONCLUSION

Based on the results and discussion above it can be concluded, that the prototype of the production of paving blocks made from plastic waste consists of a heating tube measuring 50 cm high, 30 cm diameter made from stainless plate capable of accommodating 1 kg of waste in a single production process. The temperature determined in the heating tube is 200 °C, sourced from a heater with a temperature set at 500 °C. To produce 2 units of sized paving blocks (5x10x25) cm. time 70 minutes, when the initial production of paving blocks and subsequent production for 20 minutes. Laboratory test results of the compressive strength of paving block reached 230 kg / cm². To maintain temperature and temperature stability, 2 temperature sensors are installed, ie 1 sensor unit is installed in a heating tube and 1 unit is installed in the heater section. As a pressure controller in a tube fitted with a pressure sensor, the pressure is set to 2 bar, if the excess pressure then FX-4N 2AD, will give a signal to the PLC to then order FX-4N DA, immediately open the control valve so that more pressure is issued from the tube through the pipe planned

References

- Bakhtiar, Muhammad Yannefri .. Posdaya, 2012, An Implementation of the Paradigm of Bottom Up Planning and Community Based Development. Jakarta
- Basriyanto, 2017, Harvesting Trash. Canisius-accessed dare the Internet. WIKIPEDIA, Thursday, April 16 2017, at 15.00 WIB.
- Hadiwijoto, S, Handling and Utilization of Waste. Idayu Foundation Publisher. Jakarta, 2012
- Law No. 18 of 2008. Concerning Waste Management, Jakarta. 2008
- M. Budianto, A. Wijaya, 2013, Introduction to the Porgram Logic Controller Basics. Gava Media, Yogyakarta.
- M. Hariansyah, Ahcyar Eldine, 2016. Development of Appropriate Technology in Plastic Waste Management, Financial Balance Vol 11 No 2, September 2016, ISSN 1858-2214, Scientific Journal of Accounting and Finance Accounting Study Program, Faculty of Economics, Ibn Khaldun University Bogor. 2016
- Mitsubishi, 2013, FX Series Programming Manual, Mitsubishi, Tokyo.
- Prasetyo PEA, 2016. Design of Plastic Garbage Shredder with a Capacity of 250 Kg / Hour. Aneka Mesin, Jakarta.