

# The Hydraulic Infinite Linear Actuator – properties relevant for control

**Martin Hochwallner**

Division of Fluid and Mechatronic Systems, Linköping University, SE-581 83 Linköping, Sweden

E-mail: martin.hochwallner@liu.se

**Magnus Landberg**

Saab Aeronautics, SE-582 54 Linköping, Sweden

E-Mail: magnus.landberg@saabgroup.com

**Petter Krus**

Division of Fluid and Mechatronic Systems, Linköping University, SE-581 83 Linköping, Sweden

E-Mail: petter.krus@liu.se

## Abstract

Rotational hydraulic actuators, e.g. motors, provide infinite stroke as there is no conceptual limit to how far they can turn. By contrast linear hydraulic actuators like cylinders provide only limited stroke by concept. In the world of electrical drives, linear motors provide infinite stroke also for linear motion. In hydraulics, the presented Hydraulic Infinite Linear Actuator is a novelty. This paper presents the novel Hydraulic Infinite Linear Actuator (HILA). The contribution is an assessment of properties relevant for control like high hydraulic stiffness and is based on analysis, simulation and measurements.

KEYWORDS: novel actuator, infinite linear stroke, cylinder, control

## 1 Introduction

Rotational hydraulic actuators, e.g. motors, provide infinite stroke as there is no conceptual limit to how far they can turn. By contrast linear hydraulic actuators like cylinders provide only limited stroke by concept. In the world of electrical drives, linear motors provide infinite stroke also for linear motion. In hydraulics, the presented Hydraulic Infinite Linear Actuator (HILA) /1/ is a novelty.

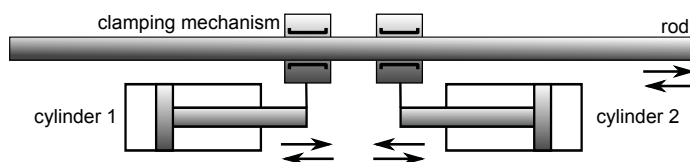

Figure 1: Concept of HILA

Hydraulic Linear Actuators, also known as cylinders, are common and mature components of hydraulic systems. Ongoing research focuses on secondary control with multi-chamber cylinders, e.g. /2/, and various concepts of digital hydraulics, e.g. /3/. Competing concepts for hydraulic cylinders are for example motors, with gear pinion and gear rack or with leading screw. A concept similar to the one presented is the so-called inch-worm motor which is usually based on piezoelectric actuators or shape memory alloy.

Conventional hydraulic cylinders and for example solenoids for directional valves /4/ provide limited stroke. For these actuators, the stroke is defined and limited by the concept. Other actuators like hydraulic or electric motors, have no conceptual limit in stroke length even though the stroke may be limited by the application.

The word 'infinite' is used in contrast to 'limited' and may not relate to common concepts of infinity. For this contribution, the authors characterize infinite stroke actuators as follows.

- The actuator may be applicable in applications which require long or unlimited stroke.
- The behaviour of the actuator is in good approximation independent of the stroke length.
- The behaviour of the actuator is in good approximation independent of the actuator position.
- The actuator can be designed, produced and sold without knowing the actual stroke length.

The last three properties may make HILA a component for Agile-Systems or an Agile-component, /5/. In that contribution, the word 'agile' refers to 'operational adaptability and the sustainment of that adaptability in an uncertain and evolving environment'. As the stroke length of an HILA can be adapted after production and properties perceived by the surrounding system do not change with stroke length. This makes HILA a candidate for a module of agile architecture.

The development of the HILA is at an early stage. Investigations and experiments have been performed, /1/, and a proof of concept has been built and successfully tested.

Buckling is one of the limiting factors for long stroke length in conventional cylinders. Also the presented concept, HILA does not come around the buckling problem. In this contribution, buckling is ignored. The authors assume that buckling can be prevented for medium stroke length applications by dimensioning the rod, and for long stroke length applications by limiting to pulling loads or by pre-tensioning the rod. Other effects like oscillations of the rod are also ignored. Variants of the HILA concept featuring external clamping mechanisms have been discovered which indeed come around the buckling problem. These variants need further investigation and are not part of this contribution.

This contribution focus on the assessment of properties relevant for the design of control systems for the Hydraulic Infinite Linear Actuator. Other concerns like wear, energy efficiency, safety, reliability, and applications are not within the scope of this paper.

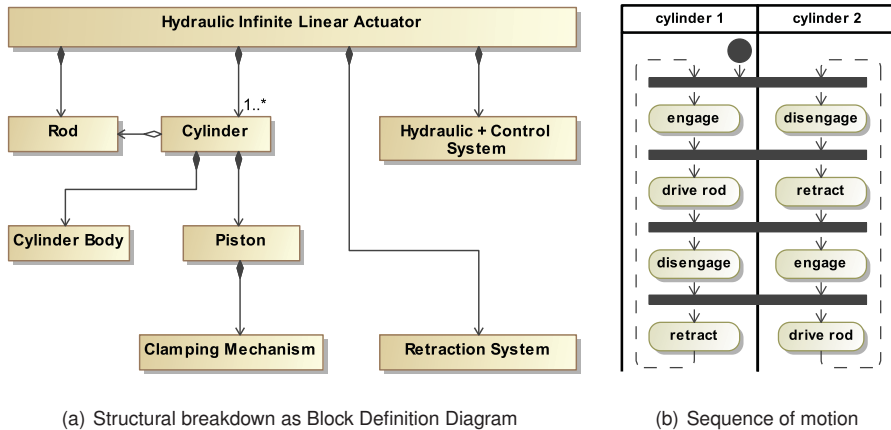

**Figure 2:** HILA in SysML diagrams, see /6/ and /7/

## 2 The Actuator

### 2.1 Basic Working Principle

The basic working principle is similar to the concept of piezo-actuators called inchworm motor. HILA consists of two cylinders which are detachable connected to a common rod via clamping mechanisms as shown in Figure 1. The movement of the rod is carried out by alternately engaging at least one of the cylinders and driving the rod in a kind of cyclic rope climbing motion, see /1/. As shown in Figure 2(b), see also the lower half of Figure 5, the cycle starts by cylinder 1 engaging while cylinder 2 disengages. Cylinder 1 then drives the rod while the other retracts. After this, the cylinders switch roles and cylinder 2 engages and drives the rod while cylinder 1 disengages and retracts.

For this basic concept and its variants, many possible implementation can be found. Figure 2(a) shows the basic components of a HILA as structural breakdown in the form of a SysML Block Definition Diagram. This diagram shows that an HILA consists of a rod and at least one cylinder which consists of piston and cylinder body. Further on, there is a hydraulic system, a control system and optionally a retraction system.

In this contribution, HILA refers to the whole actuator and cylinder to the part of HILA, see Figure 2(a). A conventional cylinder is an entire actuator and thus the counterpart to the whole HILA actuator in comparisons.

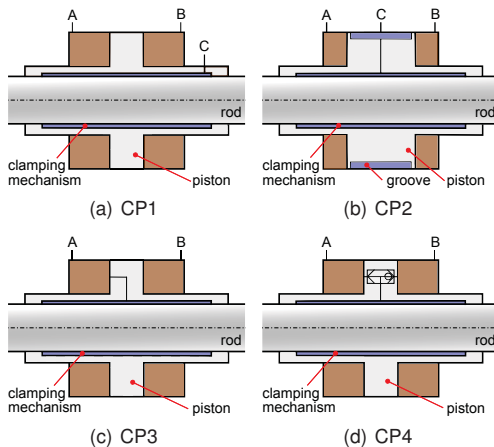

**Figure 3:** Alternative connections for the clamping element

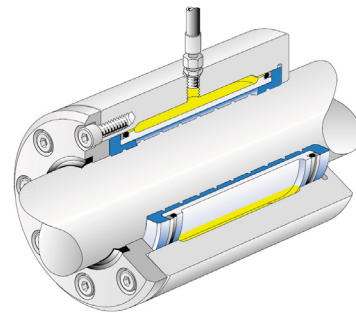

**Figure 4:** Hydraulic hub-shaft connection, see /8/

## 2.2 Clamping Mechanism

For this contribution, the hydraulic hub-shaft connection ETP-OCTOPUS O from ETP Transmission AB, see Figure 4, /8/ and /1/, has been chosen as clamping mechanism. This off-the-shelf product is used within HILA in a new application. As Figures 3 shows, one or more of these clamping elements are built into the piston. The pressurization of the clamping element (CP) and thus engaging can be implemented in the following ways:

**CP1:** by a separate port C through the piston,

**CP2:** by a separate port C at the cylinder body and a groove in the piston long enough to cover the whole stroke and connected to the clamping element,

**CP3:** by a connection to one dominant cylinder chamber (A) or

**CP4:** via a shuttle valve built into the piston.

Variant CP1 is the simplest but requires a flexible connection moving at piston velocity. Variant CP2 is less compact than the other variants as it requires a piston which is longer than the stroke length. Additionally, it has worse efficiency as the piston sealings are pressurized when engaged. CP3 and CP4 use the chamber pressures to pressurize the clamping mechanism and two functions, driving and engaging, are therefore coupled, /9/. This leads to wanted or unwanted emerging functionality. CP3 is simpler but can only be applied for a limited set of applications. CP4 uses a shuttle valve and thus adds an additional component. Later discussed properties are valid for all variants, CP1 - CP4, unless stated otherwise.

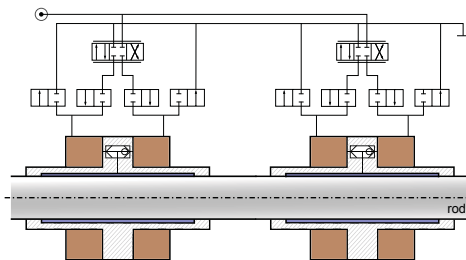

**Figure 5:** Hydraulic schema with on/off valves for disengaging

### 2.3 Hydraulic Circuit

There are also many variants of hydraulic schemas imaginable to realize the functionality. They vary depending on the variant for pressurization, see Section 2.2. The variants CP1 and CP2 with separate ports for clamping can be implemented like a usual cylinder but with additional fast 3/2 valves for clamping. CP3 and CP4 use the pressure in the cylinder chambers and thus the pressure levels in the chambers have to be controlled. One way is to connect one valve on each port to control the pressure. Another way is shown in Figure 5, where on/off valves are used to depressurize the cylinder chambers.

## 3 Properties and Effects

In this section, properties of HILA are analysed. This contribution does not focus on one single application but analyses the HILA to build the basis for design control strategies and to decide whether and where the concepts can provide benefits.

### 3.1 Hydraulic Stiffness and Natural Frequency

In applications with low-damped systems, like mobile cranes, the elasticity of the hydraulic system in combination with high inertial load is a limiting factor. A spring is formed by a cylinder due to compressibility of fluid. Spring and inertia form an oscillatable system where the natural frequency is given by following equations, see /10/ [pages 211-223].

$$\omega_n = \sqrt{\frac{k_h}{m}} \quad (1)$$

$$k_h = \frac{A_A^2 \beta}{V_A} + \frac{A_B^2 \beta}{V_B} \approx \frac{A_A \beta}{L_A} + \frac{A_B \beta}{L_B} \quad \text{where } L_A + L_B = L \quad (2)$$

The dotted u-shaped curve in Figure 6(b) shows the natural frequency,  $\omega_n$ , of an exemplary, long conventional cylinder. The considered dead volume limits the natural frequency near the end stops. An HILA cylinder has substantially smaller volumes and thus higher natural frequencies, as shown by the lower, solid curve in Figure 6(a). Further,

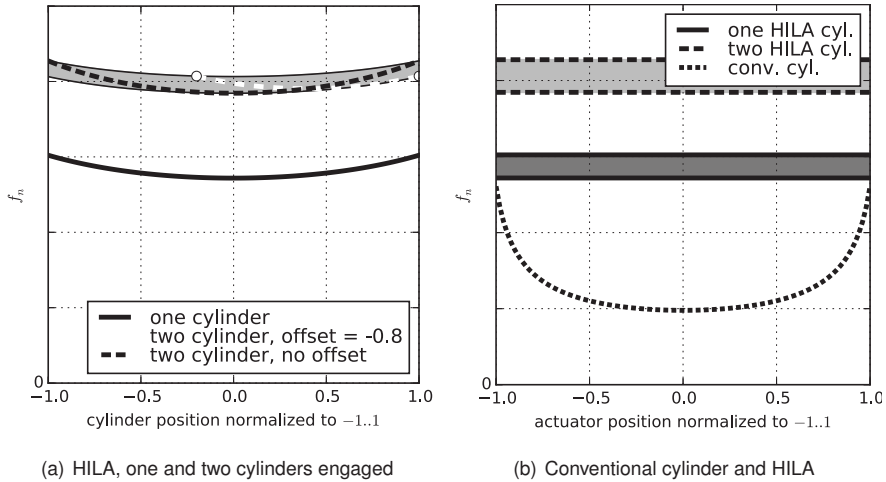

**Figure 6:** Natural frequencies of a conventional cylinder and HILA

the natural frequency does not change with the stroke length of the actuator. All HILAs featuring equal cylinders have the same stiffness and thus the same natural frequency independent of their stroke length. Conventional cylinders change their stiffness for a certain position according to Equation 2.

$$k_H \propto \frac{A_P \beta}{L} \quad (3)$$

In the considered HILA, two cylinders are alternately connected to the rod. During the transition between the two cylinders or as distinct mode, see Section 3.3, both cylinders can be connected to the rod. In that case, the spring rates of the two cylinders are added together and the natural frequency is further increased.

As long as a retraction system does not couple the positions of the two cylinders, all combinations of the positions of the cylinders may occur. The upper gray area in Figure 6(a) shows the natural frequencies of various combinations of piston positions. The dashed curve shows the natural frequencies for the case where both cylinders are coupled in the same position and thus a full stroke is possible. The white dashed curve shows the case when positions of the cylinders have an offset of -0.8 to each other and thus less stroke is possible as the other piston reaches the end stop earlier. Without knowing the current state of the cylinders, only a range of possible natural frequencies can be defined for an actuator position as shown in Figure 6(b). When one cylinder is engaged, the lower dark gray range applies and when two cylinders are engaged, the upper gray range applies.

### 3.1.1 Higher pressure levels

When designing hydraulic systems, choosing higher pressure levels may lead to more compact components as less flow is required for conveying the same power. One limiting factor when increasing pressure levels is that this will lead to lower natural frequencies in the system. It can be shown that the lowest natural frequency,  $\omega_n$ , for a cylinder in a given system follows

$$\omega_n \propto \sqrt{\frac{\beta}{L p_{\text{design}}}} \quad (4)$$

where  $p_{\text{design}}$  is the design pressure, e.g. the supply pressure. An HILA is subject to the same rule but  $L$  is much shorter and thus the natural frequencies are higher than for conventional cylinders.

### 3.1.2 Infinite stationary hydraulic stiffness

The considered concept, HILA, allows moving the piston of the disengaged cylinder without moving the rod. Thus, when the desired position is reached the piston of the disengaged cylinder can be moved to one of its end stops. After engaging the cylinder and pressurizing the one cylinder chamber to push the piston against the end stop, the elasticity of the mechanical contact is dominating the cylinder stiffness, see Figure 7(a). The hydraulic stiffness thus becomes infinite. In this consideration, the elasticity of all mechanical components like structure and rod are ignored.

To increase the conveyable force, the piston of the second cylinder may also be pushed against the end stop pointing in the same direction, see Figure 7(b). Alternatively, there exists the option to place both pistons on their opposed end stops, see Figure 7(c). In this case, the pistons and rod are purely mechanically locked and pressurizing of the cylinders is not required for CP1 and CP2. The drawback of this approach is that backlash may occur and thus the stiffness of the actuator for small movements is indefinite. This property may replace an additional clamping mechanism or active position control in for example a lift or crane application during loading and unloading.

### 3.1.3 Controlled passive damping

The concept in Section 3.1.2 can be used to introduce hydraulically controllable friction forces, and thus damping, in the system. When, in the first approach in Section 3.1.2, shown in Figure 7(a), the second cylinder is partially engaged, the piston slips on the rod, providing a damping effect by friction. The degree of engagement, i.e. the friction force, can be controlled by the clamping pressure,  $p_{\text{clamp}}$ .

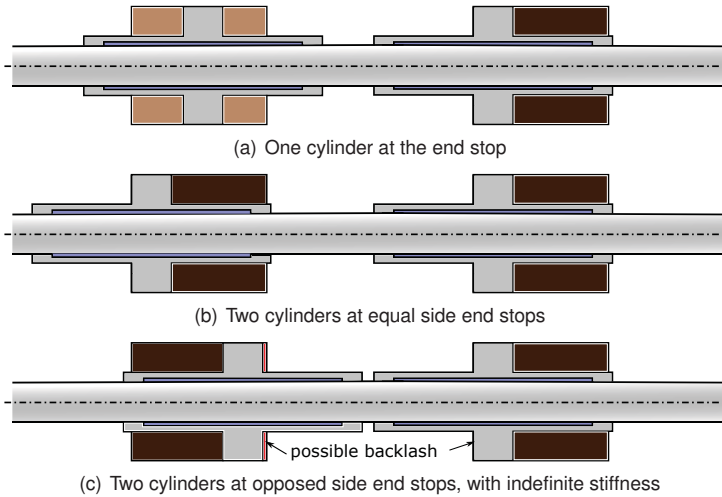

**Figure 7:** Infinite hydraulic stiffness with HILA

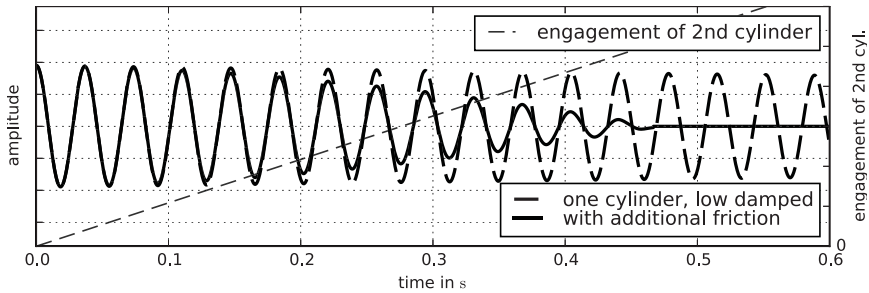

**Figure 8:** Free oscillation and controlled friction

Figure 8 shows the results of a simulation of a low-damped actuator mass system with closed valves and an applied force step. The dashed curve shows the case without additional friction. The solid curve shows the case where the engagement which equals the clamping pressure, thin dashed line, and thus the frictions gradually increases and reduces oscillations.

### 3.2 Hydraulic Capacitance

As shown in Figure 6(b), the natural frequency of a cylinder mass system depends on the cylinder position. Based on the same cause, varying chamber volumes, the hydraulic capacitance of the cylinder chambers, /10, page 225-226/, also depends on the cylinder position, as shown in Figure 9.

$$C_h = \frac{V}{\beta} = \frac{V_0 + Ax}{\beta} \quad (5)$$



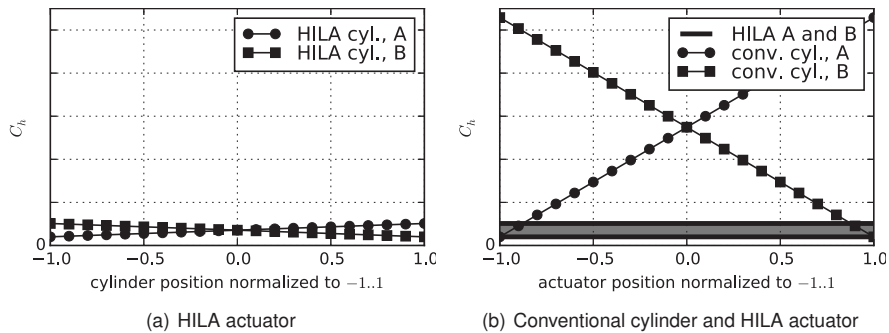

**Figure 9:** Capacitance of cylinder chambers of a conventional cylinder and an HILA

Figure 9(a) shows the capacitance of chambers of cylinders of a HILA. The circle and square curves in Figure 9(b) show the same for a conventional cylinder. Both cases start at the same value as the HILA cylinders and the conventional cylinder have the same dead volume but the capacitance of the conventional cylinder increases more. As described in Section 3.1, the capacitance of the chambers of a HILA also varies in a range for a given actuator position as the cylinder position varies, see the gray bar in Figure 9(b).

The dependency of the capacitance on the cylinder position leads to non-linear behaviour of the system. Because of HILA's smaller chamber volumes, big dead volumes relative to the chamber volumes can be accepted. This leads to smaller variations and thus less apparent non-linearity due to the dependency of the capacitance on the cylinder position. The HILA has much smaller chamber volumes and thus lower capacitance, which may be an advantage in various applications.

### 3.3 Secondary Control

As discussed in Section 3.1 and shown in Figure 6, HILA features three modes – whereby none, one or both cylinders are engaged. In common operation for long strokes, the actuator switches between modes where the cylinders engage alternatingly with an intermediate period where both are engaged.

For stroke lengths up to the cylinder stroke length a mode where both cylinders are continuously engaged is practical. In this mode, the effects of both cylinders are added together and thus twice the force is available. Consequently HILA can be dimensioned for the lower force required on the long stroke and a short work stroke with higher force.

Further, a mode exploiting the inertia of the load and disengaging temporarily both cylinders, the so-called ballistic or free-wheeling mode, seems to be a promising alternative.

### 3.4 Friction

A conventional cylinder can apply the full hydraulic force on the rod. With HILA, the force applied on the rod is limited by the clamping force and thus the clamping pressure,  $p_{\text{clamp}}$ . Depending on the application it may be desirable to limit the rod force but in most cases it can be expected that the full hydraulic force shall be applied on the rod.

Concepts CP1 and CP2, shown in Section 2.2, allow independent control of the clamping pressure and thus the clamping force. In concepts CP3 and CP4, the clamping pressure depends on the chamber pressures and thus on the load. This leads to wanted or unwanted emerging functionality, see Section 3.4.3.

For HILA, the friction forces can be split into two parts according to the two motions, between piston–cylinder-body and between piston–rod.

#### 3.4.1 Friction between piston and cylinder body

The HILA cylinders have three sealing packages and potentially bigger sealing diameters than conventional cylinders. Higher friction losses can therefore be expected. A concept to reduce friction in HILA for some applications was presented in /1/. A detailed friction model for hydraulic cylinders is not part of this contribution. Nevertheless, low cylinder friction is crucial for concepts CP3 and CP4, see Section 3.4.3.

#### 3.4.2 Clamping – friction between rod and piston

Simplified, the clamping force can be modelled as coulomb friction as follows.

$$F_{\text{clamp}} = \begin{cases} F_{\text{clamp}0} & \text{when: } p_{\text{clamp}} < p_{\text{clamp}0} \\ F_{\text{clamp}0} + \mu A_{\text{clamp}} (p_{\text{clamp}} - p_{\text{clamp}0}) & \text{else} \end{cases} \quad (6)$$

More advanced friction models that include effects like sliding, oil squeezing and oil stiction are not considered in this contribution. According to the manufacturer, /8/, of the clamping element the design friction coefficient is  $\mu = 0.1$  but in usual applications friction coefficients up to  $\mu = 0.2$  are common, see also /1/. HILA uses the clamping element in a new application and thus there is no broader data basis available yet. Figure 10 shows the range of the clamping force whereby the friction coefficient, the  $p_{\text{clamp}0}$  and  $F_{\text{clamp}0}$  vary within an interval. Additionally, the dashed curve shows for concepts CP3 and CP4 the clamping pressure resulting from a load according Equation 11 and the assumptions discussed in Section 3.5. The shown case illustrates a HILA designed to carry the full hydraulic force at a friction coefficient of  $\mu = 0.1$ . With a lower friction coefficient, e.g.  $\mu = 0.05$ , the clamping element will slide already at partial load.

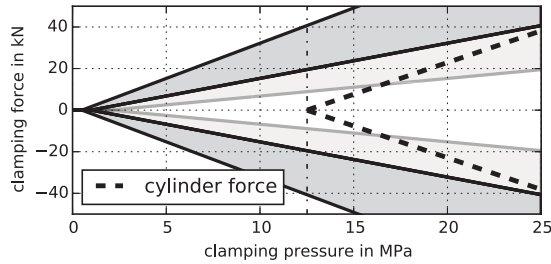

**Figure 10:** Clamping force at various friction coefficients:  $\mu = (0.05), 0.1, 0.2$

Ignoring  $F_{\text{clamp}0}$  leads to the following design rule for safe clamping.

$$\begin{aligned}
 F_{\text{clamp}} &> |F_{\text{cyl}}| \quad \text{for all levels of } p_A \text{ and } p_B \\
 \mu A_{\text{clamp}} (p_{\text{clamp}} - p_{\text{clamp}0}) &> A_P (p_A - p_B) \\
 \frac{\mu A_{\text{clamp}}}{A_P} &> \frac{p_{\text{supply}}}{p_{\text{supply}} - p_{\text{clamp}0}} \\
 A_{\text{clamp}} &> \frac{A_P}{\mu} \frac{p_{\text{supply}}}{p_{\text{supply}} - p_{\text{clamp}0}} \quad (7)
 \end{aligned}$$

### 3.4.3 Self-Clamping

An HILA of concept CP3 or CP4 designed according to Equation 7 can create safe clamping pressure from the load force. This means in the case of a stop when the hydraulic connections to the cylinder are closed while the cylinder is engaged, that the cylinder can maintain the necessary pressure for clamping by itself. No external pressure supply is therefore needed in this case.

For concepts CP3 and CP4, unintended engaging may occur when the piston is to be retracted. The equation of motion for retraction is

$$m_P \dot{x}_P = (p_A - p_B) A_P - F_{f_{\text{piston-body}}}(p_A, p_B, \dot{x}_P, t) - F_{\text{clamp}}(p_A, p_B, \dot{x}_P - \dot{x}_R) \quad (8)$$

If  $p_A$  or  $p_B$  reaches  $p_{\text{clamp}0}$ , additional pressure will increase the clamping force, see Equation 6. If the HILA is designed according to Equation 7, the increase in the clamping force will be at least as big as the increase in the piston force. Higher pressure will thus not lead to higher acceleration but engaging. Therefore, for CP3 one and for CP4 both chamber pressures,  $p_A$  or  $p_B$ , must be kept below  $p_{\text{clamp}0}$  while retracting. HILA thus requires cylinders with low friction, a hydraulic circuit featuring this low pressure level and a controller with low pressure overshoots.  $p_{\text{clamp}0}$  is a property of the clamping mechanism which may be altered. Additionally, this limits acceleration of the cylinders and thus the velocity of HILA.

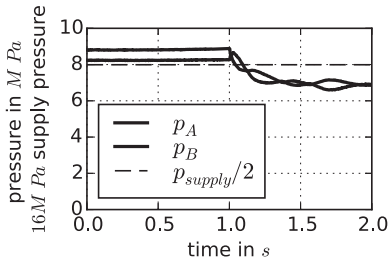

(a) Fluctuating pressure levels

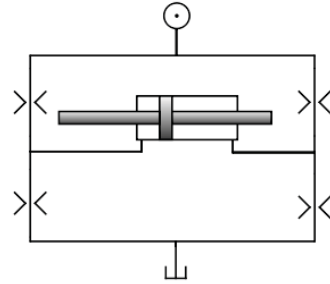

(b) Model of a spool valve and cylinder

**Figure 11:** Pressure levels in servo valves

### 3.5 Pressure Levels in Servo Valves

In a conventional symmetric cylinder, the system behaviour depends mainly on the load pressure,  $p_{load}$ .

$$p_{load} = p_A - p_B \quad (9)$$

By contrast, the functionality of HILA in variants CP3 and CP4, see Section 2.2, also depends on the pressure levels,  $p_A$  and  $p_B$ , as they are responsible for clamping. The usual assumption, see /10, pages 124 and 130/, for symmetric cylinders and spool valves is

$$\frac{p_A + p_B}{2} = \frac{p_{supply}}{2} \quad (10)$$

Regarding the variant with the shuttle valve, reliable clamping depends on the following assumption, as discussed in Section 3.4.2.

$$p_{clamp} > p_{clamp, lower limit} = f(p_{load})$$

$$p_{clamp} = \max(p_A, p_B) = \frac{p_{supply}}{2} + \left| \frac{p_{load}}{2} \right| \quad (11)$$

Experiments show that the assumption in Equations 11 and 10 does not always hold true and thus safe clamping may be compromised, see Figure 11(a). This segment of a recording of an experiment shows the pressure levels of the cylinder chambers when moving the cylinder at low velocity and then stopping at  $t = 1s$ . The oscillations originate from weaknesses in the support structure and are not of relevance. In this experiment, the assumption is violated for more than 10 bar or 12.5%. Other experiments with the same valve show violations up to 20 bar or 25%.

This phenomenon can be explained as follows. According to /10, page 130/, a servo valve can be modelled as shown in Figure 11(b). Near the centre position of the valve, all these orifices are nearly closed. The openings are small compared to the design situation and

thus substantial relative errors for the opening areas may occur. The error may change for example with temperature and the location of the spool (angle and position). Small imperfections in the valve may result in any pressure in the cylinder chamber from  $p_{\text{tank}}$  to  $p_{\text{supply}}$  when both upper orifices are bigger than the lower or vice versa.

The effect on the load / cylinder / controller is  $p_{\text{load}} = p_A - p_B$  and not the actual pressure levels.  $\frac{p_A + p_B}{2}$  can thus also change over a wide range and there is no guarantee that it may stay somewhere around  $\frac{p_{\text{supply}}}{2}$ . As this has little effect in the normal operation of a servo valve, this is not a main quality criterion for the valve. As HILA is dependent on the pressure levels for clamping, this may be problematic as there is no lower limit for  $\min(\max(p_A, p_B))$ . This investigation points out that this phenomenon exists but can not quantify it. It is based on measurements on only one valve. A workaround is to add orifices between the supply pressure and the cylinder chambers which provide flow in the magnitude of the leakage of the valve and thus pull the pressure levels up.

#### 4 Conclusions

HILA is a novel hydraulic linear actuator. It translates the inchworm concept to hydraulics and its magnitude of force and speed. HILA consists of two short cylinders whose pistons are detachable connected to a common rod. During motion, alternately one cylinder is engaged and drives the rod while the other retracts.

The development of the HILA is at an early stage. Investigations and experiments have been performed, [1], and a proof of concept has been built and successfully tested.

The HILA concept introduces more complexity than conventional cylinder but features interesting properties. This contribution deals with advantages and limitations of the HILA concept. It does not focus on one single application but analyses HILA to build a basis for design control strategies and to decide whether and where the concepts can provide benefit. Superior properties are the low hydraulic capacitance and thus high hydraulic stiffness and high natural frequency which are independent of the stroke length and close to independent of the position. Also discussed are capabilities like infinite stationary hydraulic stiffness and secondary control for linear actuators. Depending on the chosen variant of the concept, there may emerge wanted or unwanted functionalities which are related to the pressure levels in the cylinder chambers and friction.

Ongoing work will focus on improving the understanding of the HILA components like the friction models for the cylinder and the clamping element. Control strategies aiming for performance and energy efficiency will be developed.

## 5 Bibliography

- /1/ Magnus Landberg, Martin Hochwallner, and Petter Krus. Novel Linear Hydraulic Actuator. *ASME/BATH 2015 Symposium on Fluid Power & Motion*, 2015.
- /2/ Matti Linjama et al. Secondary Controlled Multi-Chamber Hydraulic Cylinder. In *The 11th Scandinavian International Conference on Fluid Power, SICFP09*, 2009.
- /3/ Helmut Kogler. *The Hydraulic Buck Converter - Conceptual Study and Experiments*. PhD thesis, 2012. ISBN: 978-3990330593.
- /4/ Eberhard Kallenbach. *Elektromagnete: Grundlagen, Berechnung, Entwurf und Anwendung*. Vieweg+Teubner Verlag, Wiesbaden, 2012. ISBN: 978-3834809681.
- /5/ Rick Dove. Agile Systems-Engineering and Agile-Systems Engineering. *INSIGHT – International Council on Systems Engineering (INCOSE)*, Volume 17(Issue 2), 2014.
- /6/ Sanford Friedenthal, Alan Moore, and Rick Steiner. *A Practical Guide to SysML*. Morgan Kaufmann, OMG, 2nd edition, 2011. ISBN: 978-0123852069.
- /7/ Website of NoMagic – Cameo Systems Modeler. <http://www.nomagic.com/products/cameo-systems-modeler.html>, visited 2015-09-14.
- /8/ Website of ETP Transmission AB. <http://www.etp.se/>, visited 2015-09.
- /9/ Nam Pyo Suh. *The Principles of Design*. Oxford University Press, 1990.
- /10/ John Watton. *Fundamentals of Fluid Power Control*. Cambridge University Press, Cambridge, UK New York, 2009. ISBN: 9780521762502.
- /11/ Herbert E. Merritt. *Hydraulic Control Systems*. Wiley, 1967. ISBN: 0 471 59617 5.

## 6 Nomenclature

$\beta$	bulk modulus .....	Pa
$\omega_n$	natural frequency of the system .....	$\frac{\text{rad}}{\text{s}}$
$A_C$	area relevant for clamping .....	$\text{m}^2$
$A_P$	piston area .....	$\text{m}^2$
$C_h$	hydraulic capacitance of a cylinder chamber .....	$\text{m}^3/\text{Pa}$
$F_{\text{clamp}}$	force which the clamping mechanism can convey .....	N
$F_f$	friction force .....	N
$k_h$	hydraulic spring rate of an actuator .....	$\frac{\text{N}}{\text{m}}$
$L$	stroke length of an actuator .....	m
$m$	mass / inertia .....	kg
$p_{\text{clamp}}$	pressure on the clamping element responsible for clamping	Pa
$p_{\text{clamp}0}$	negative pre-tension of the clamping element .....	Pa
$x_P$	cylinder position .....	m
$x_R$	rod position .....	m