

Optimization of pneumatic vacuum generators – heading for energy-efficient handling processes

Dr.-Ing. Harald Kuolt, B.Eng. Jan Gauß, Dr.-Ing. Walter Schaaf,

Dipl.-Ing. Albrecht Winter

J. Schmalz GmbH, Aacher Str. 29, 72293 Glatten, Germany, E-Mail: harald.kuolt@schmalz.de, jan.gauss@schmalz.de, walter.schaaf@schmalz.de, albrecht.winter@schmalz.de

Abstract

In current production systems, automation and handling of workpieces is often solved by use of vacuum technology. Most production systems use vacuum ejectors which generate vacuum from compressed air by means of the Venturi effect. However, producing vacuum with compressed air is significantly less efficient than using other principles. To minimize the energy costs of pneumatic vacuum generation or to make full use of the energy available, it is important that the inner contour of the nozzle is shaped precisely to suit the specific application - also the system's flow conduction needs to be optimal and the flow losses have to be minimized.

This paper presents a method for optimally designing pneumatic vacuum generators and producing them economically even at very low lot sizes in order to keep the operation costs low and address other concerns (such as noise emissions) as well.

KEYWORDS: CFD, flow simulation, additive manufacturing, automation, vacuum generation, ejector

1. Vacuum generation in handling technology

In current production systems, automatic handling of workpieces using vacuum technology is widespread. This is primarily because this technology is easy to implement, easy to use and robust. Thus, it can be applied to a broad range of applications. In principle, a vacuum system consists of at least two elements: the actual suction pad, which represents the contact point with the workpiece, and the vacuum generator, which is connected to the suction pad by fluidic connection elements, such as a hose or other fluid connectors.

Most production systems use vacuum ejectors which generate vacuum from compressed air by means of the Venturi effect. The advantages of this sort of ejectors are its compact size and low weight, its high power density, and its simple and robust

design with no moving parts. This makes it possible for vacuum ejectors to be mounted directly on the handling system even at high accelerations, shortening the required hose lengths, reducing flow restriction and ensuring quick evacuation times.

However, producing vacuum with compressed air is significantly less efficient than using other principles. Depending on how the system boundaries are defined, only about 1%–2% of the total electrical energy provided to the overall system is actually “converted” into usable vacuum. The rest of the energy is lost during air compression, distribution through the infrastructure, right up to relaxation, acceleration and turbulent losses in the nozzle or easily is ejected through the outlet of a bad dimensioned nozzle.

As a manufacturer of vacuum components, it is the ultimate ambition for J. Schmalz GmbH to reduce the energy requirements of pneumatic vacuum generators to a minimum in order to put the available energy to the best use. This involves adapting the nozzle shape to suit the specific application, improving the flow conductance, reducing the flow losses in the system, and developing designs to make the best use of the compressed air supply, such as by the use of multi-stage systems.

Basically, a vacuum gripping system – as exemplified in **Figure 1** – is a mechanism that enables the handling of workpieces from point A to point B. And since handling is not a value-additive part of a process, it should be accomplished as quickly, reliably, reproducibly and efficiently (and therefore economically) as possible, without damaging the workpiece. Next to the actual suction pad, which is the part that actually comes into direct contact with the workpiece, the other main component of any vacuum gripping system is an electric or pneumatic vacuum generator. For minimizing the energy consumption of a vacuum suction pad, it is crucial that it has good sealing properties against the workpiece to prevent leakage. Furthermore, it should have a small interior volume that has to be evacuated during vacuum generation.

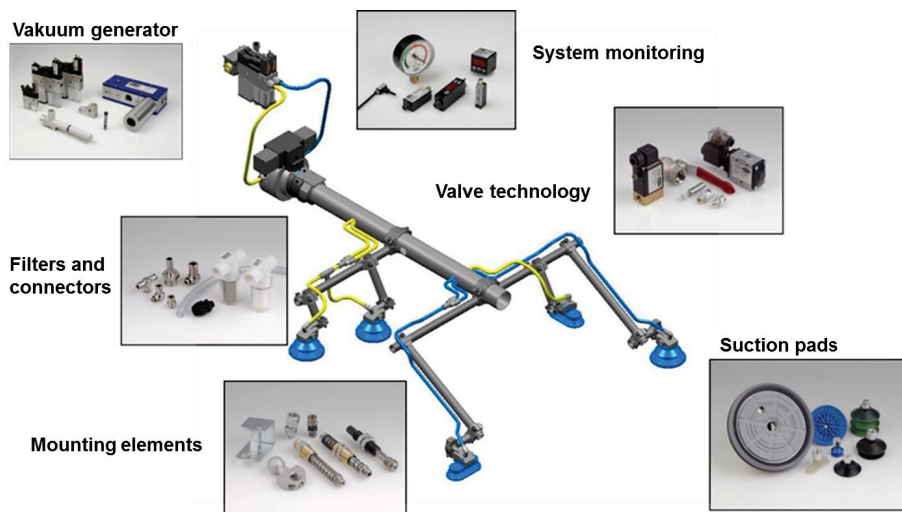

Figure 1: Elements of a vacuum gripping system [1]

A vacuum generator should be capable of a high suction flow rate to produce a high level of vacuum in a short period of time, with few internal flow losses and low overall energy consumption.

In addition to the requirements described above for the individual components, the handling process itself is another major factor in determining the efficiency of a vacuum gripping system. For example, the ejector only needs to remain engaged in the system for as long as it takes to reach the required vacuum level. If the sealing of the vacuum suction pad on the workpiece and the workpiece itself is airtight, there is no leakage and no additional power is required to maintain the vacuum level, with the result, that the ejector can be turned off. If there is leakage in the system (for example in case of worn suction pads or a leaky sealing) and the vacuum level falls below a certain critical value during the process so that the current handling step can no longer be executed, the vacuum generator starts again, compensating the small leakage. Used in compact ejectors (Figure 2), for example, this so-called “air-saving function” is state of the art, enabling energy savings of up to 90% in the handling of airtight workpieces.

On the other hand, porous workpieces, or handling processes with a high leakage rate have the effect that the “air-saving function” can’t be applied. In this case the amount of energy required for the handling process is only determined by the fluidic and thermodynamic efficiency of the nozzle in the vacuum generator. For this reason, high levels of energy efficiency can only be reached if the vacuum generator, the system monitoring, and the handling system are all perfectly adjusted to suit the process parameters.

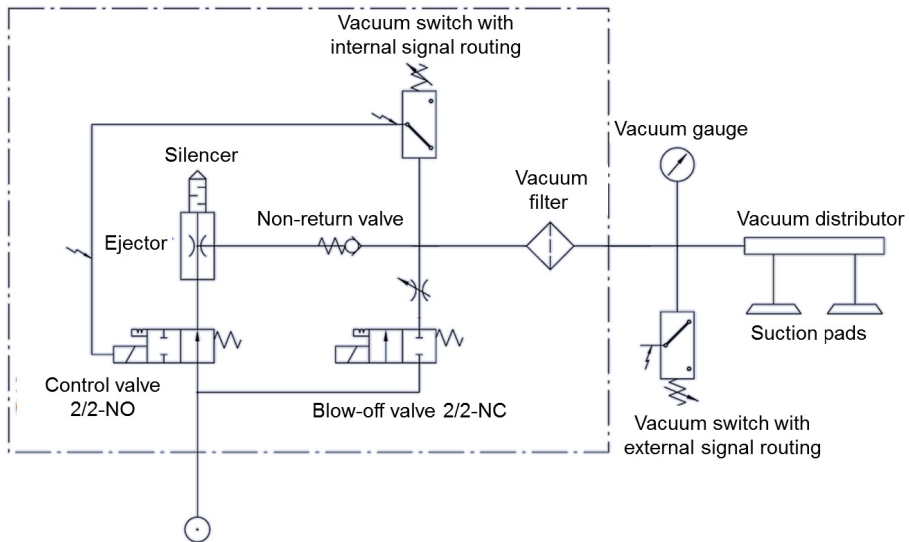

Figure 2: Pneumatic circuit diagram of a compact ejector with “air-saving function” [2]

2. Structure and fluid mechanics of an ejector

The core component of a vacuum ejector is its nozzle technology which consists of at least one drive nozzle and one or more receiver nozzles, which work in combination according to the principle of a jet pump. The combination of these two nozzles effects the vacuum generation, whereas the design of their arrangement determines the overall characteristics of the ejector.

When compressed air is fed in the ejector, the kinetic energy of the air flow increases as it moves through the drive nozzle, using the energy of the operating pressure to accelerate. Meanwhile, the static pressure drops according to Bernoulli's principle, which is an application of the law of conservation of energy.

In the right design, this effect (named the Venturi effect after its discoverer) causes that the static pressure between the drive and receiver nozzles drops far below atmospheric pressure. This pressure difference can be measured as vacuum level relatively to the atmospheric pressure. As a result of this difference in pressure and the high impulse of the driving jet, the air between drive and receiver nozzle is mixed in, and as the impulse is transferred, the air is re-compressed to the outlet pressure. Consequently, more air is drawn in through the suction port of the ejector. It is this suction flow that is used in a handling process to evacuate the internal volume of the gripping system, its hoses, and the suction pads in the shortest cycle time possible.

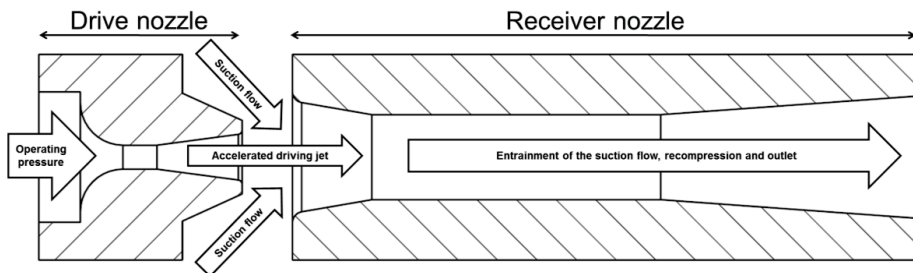

Figure 3: Structure and functioning of a single-stage vacuum ejector

3. Analogy model

The suction flow rate and vacuum level are directly related to each other by the fluid mechanics obtaining in the ejector. This relation causes the ejector's characteristic curve, which is characterized by high linearity. This is similar to a simple direct current motor: Just like the vacuum produced by an ejector, the torque produced by a DC motor is dependent on an action of force. In a motor, the force is produced by an

applied electric voltage, while in an ejector, it is induced from the air pressure supplied by the system. Both components behave similarly in that the torque of the motor increases with the voltage, and the vacuum level produced by the ejector increases with the operating pressure. Beyond, for a DC motor, any particular momentary torque value corresponds to a certain engine speed, while for a vacuum ejector, the vacuum level corresponds to a certain suction flow. Also, the two components have in common that at the motor's highest torque the rotation speed tends towards zero, while at the ejector's greatest vacuum level, the suction flow rate tends towards zero. Furthermore, the mechanical power of the motor is equal to the product of the rotation speed and the torque, multiplied by the constant factor 2π and the suction capacity of an ejector is equal to the product of the suction flow rate and the generated pressure differential. All these relations mean that any motor and any ejector have a specific ideal operating point with the greatest ratio between usable power and energy input.

Thus, in order to reach maximum efficiency, it is common to develop electric motors specifically for the intended application rather than resort to using off-the-shelf products. However, in the history of vacuum ejector technology, the economic inefficiency conventional manufacturing technology for very small lot sizes, along with the complexity of the flow processes involved, have prohibited the use of such an individualized design process.

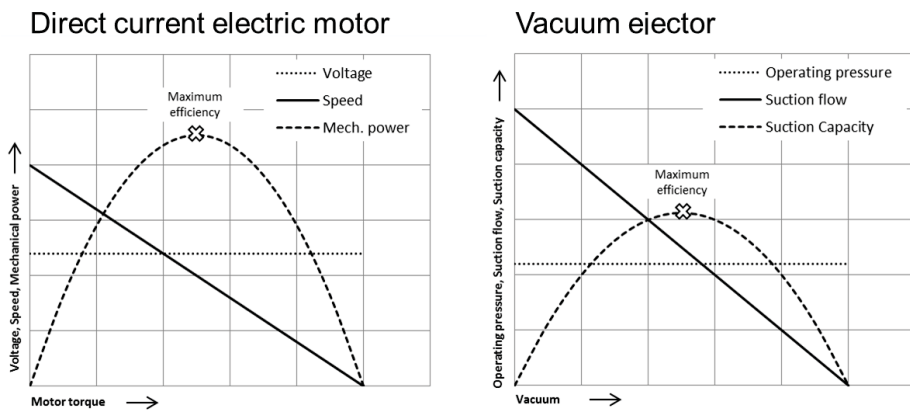

Figure 4: Characteristic curves of a DC electric motor (left) and a vacuum ejector (right)

4. Designing optimized ejector geometries

A vacuum ejector is extremely complex. In the past, the designing has always been complicated by various factors, including temporary hypersonic flow velocities up to

significantly better flow distribution and an increased Mach number in combination with less friction causing a more powerful jet along the nozzles.

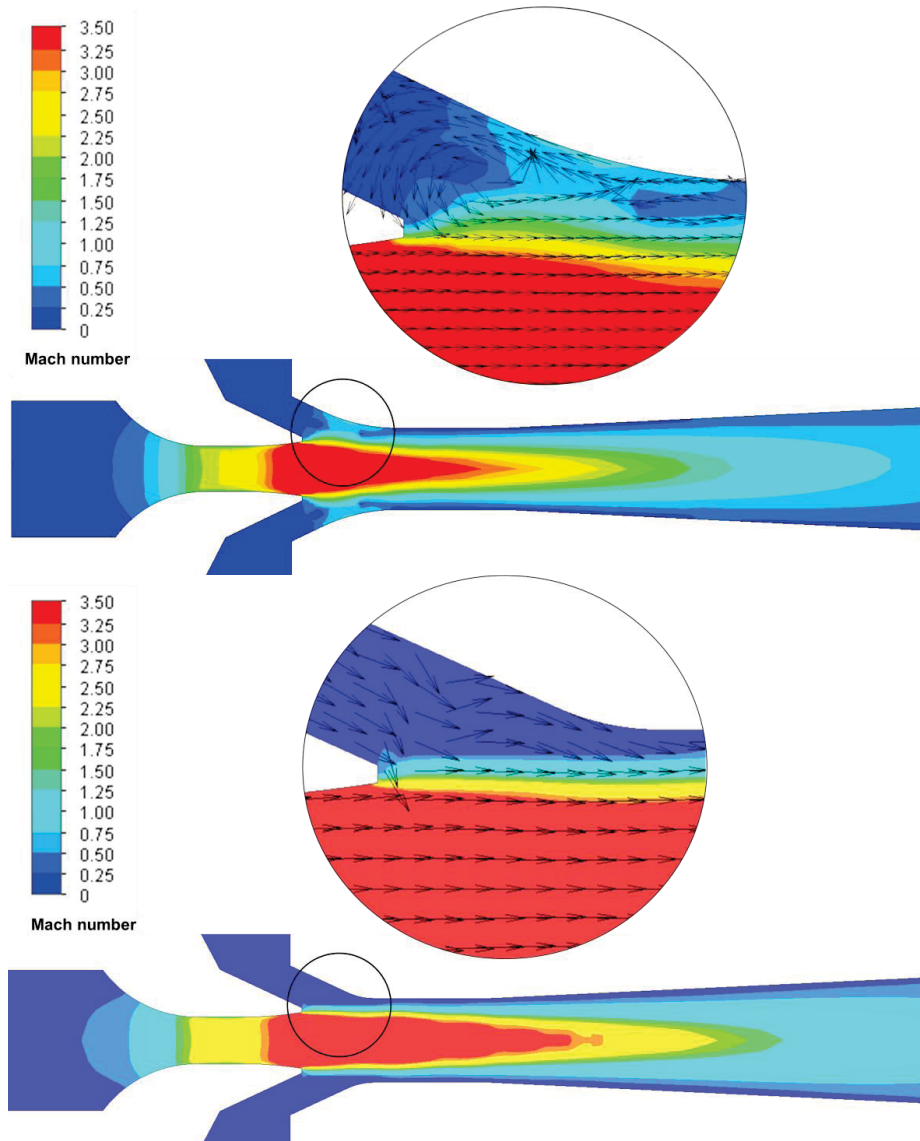

Figure 6: Flow separation and reverse flow behind the motive nozzle, before (top) and after (bottom) CFD fine-tuning of the nozzle

In ejector designs with two or more outlet nozzles, the jet retains enough energy after the first receiver nozzle in order to draw in more air through the second suction intake and push it out through the subsequent outlet nozzles (Figure 7). At moderate vacuum levels, such multi-stage ejectors can lead to a doubling of the suction flow; with low vacuum levels and a three-stage design, the flow can even be tripled.

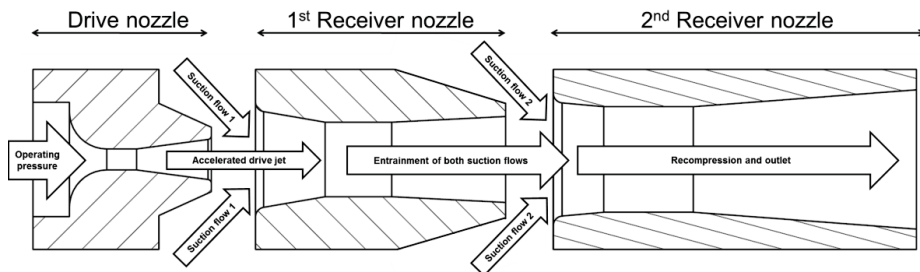

Figure 7: Structure and functioning of a multi-stage vacuum ejector

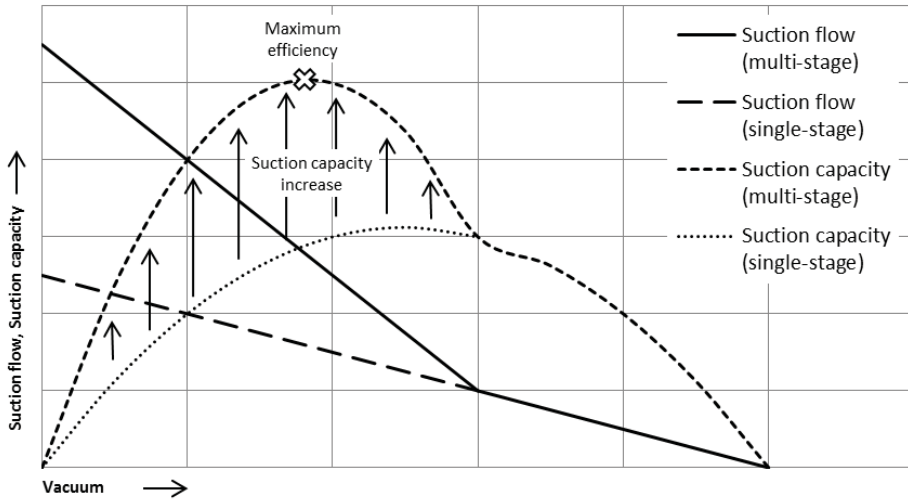

Figure 8: Characteristic curve of two-stage ejectors

Multi-stage ejectors display excellent performance in regard to suction flow rate and evacuation time. This explains why they are very popular in the market despite being more complicated in calculation and dimensioning. While a single-stage ejector's performance is determined by 15 significant geometric values, each additional receiver nozzle requires eight further parameters to be evaluated, considerably increasing the simulation and design time required.

This circumstance is caused by the fact that the flow characteristics of an ejector are affected by all of the geometric parameters simultaneously, what means that a design can only consider the interdependencies of the parameters by solving the entire system at once. Thus, each nozzle influences not only the suction performance of its corresponding ejector stage, but also the overall characteristic curve and the performance of all the other nozzle pairs, even those in previous stages. This necessarily results in a multiplicity of variations of nozzle pairings, rendering any attempt to implement standards in the market very difficult. In this respect, the multi-stage ejectors available on the market always represent just a compromise with the operating parameters of the intended application. Research shows, however, that nozzles adapted to the specific application can quickly reach up to 40% better efficiency when their characteristic curve is adjusted to ideally suit the regarding handling process.

In handling tasks so far, because of the high cost of manufacturing in a lot size of one, such specialized nozzles have not been competitive with market-oriented standardized ejectors, which are produced in large lot sizes.

5. Additive manufacturing: specialized nozzles made economically

In addition to advances in techniques for simulating and designing nozzle shapes and geometries, new manufacturing techniques have also contributed to allow specialized nozzles to find application and a place in the market. Until now, the shapes available in nozzle design have essentially been determined by the limitations of conventional manufacturing methods such as turning. Thus, producers of nozzles had to procure that nozzle designs were suited to the manufacturing method and could be produced economically. For example, undercutting operations are more difficult to execute with conventional manufacturing methods than with additive manufacturing (AM) operations (known colloquially as “3D printing”). Since by this method, material is deposited only in locations at which it is actually intended, even the most complex geometries can be simply produced by lighting or melting only one specific spot. The last few years have brought considerable advancements in AM, especially in the materials, such that in the meantime, nozzles can be printed completely out of aluminum or hard plastics without any further production steps.

Furthermore the high durability of these new printable materials enables now that printed nozzles not only are used in trials and experimental applications, but also can be marketed directly for special-purposes and special handling applications in association with a competitive price.

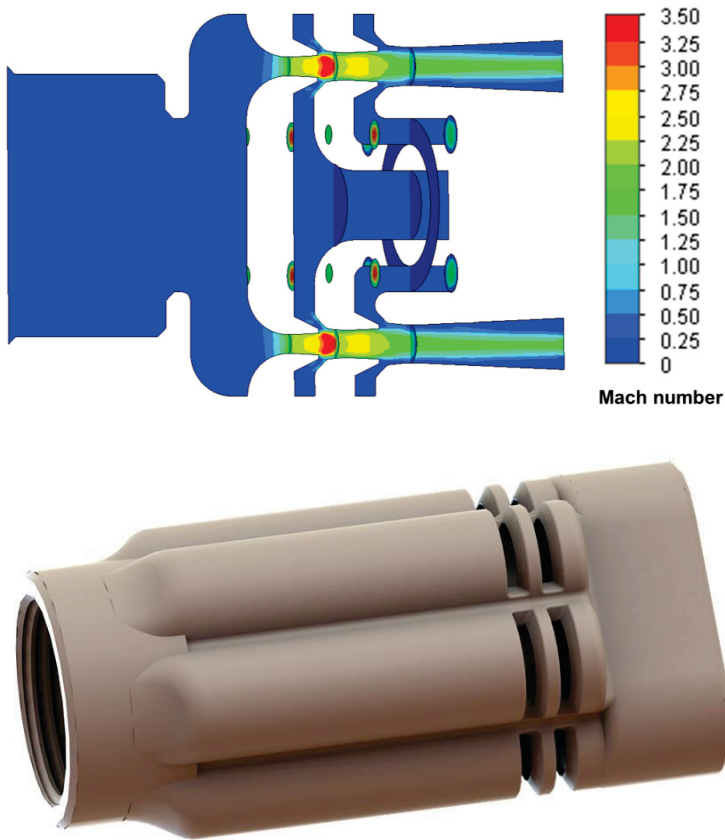

Figure 9: A specialized multi-stage ejector in CFD design (top) and in final production by means of additive manufacturing (bottom)

Fig. 9 shows an example of an ejector produced by this approach: To reach the requisite working point for an application, a customer needed a design with entirely new nozzle geometries. These were validated in simulation, and the nozzles were produced additively and verified at our in-house testbed before being shipped. This entire process chain, from CFD simulation to additive manufacturing, can be implemented at considerably less expenses than before, resulting in substantially shorter delivery times.

6. Conclusion

By use of modern CFD simulation tools, ejector nozzles can be designed with optimized flow characteristics to suit specific operating points leading to highly efficient vacuum generation for each individual application. New manufacturing techniques, such as additive manufacturing, enable that these specialized nozzle geometries can now be produced and validated immediately causing low development and production costs in combination with short delivery times.

In handling applications, these specialized ejector-nozzles permit an increase in energy efficiency of up to 40% compared to a standardized ejector that, due to surrounding conditions, must work at a non-optimal operating point. As a result of this increase in efficiency while production costs remain virtually unchanged, the total cost of ownership of these nozzles can be significantly lower.

7. References

- [1] J. Schmalz GmbH, Glatten, Germany
- [2] J. Schmalz GmbH, Glatten, Germany. Vacuum components catalog 2013/2014.

