

Experimental loss analysis of displacement controlled pumps

Dipl.-Wirt.-Ing. Jan Lux

Institute for Fluid Power Drives and Controls (IFAS), RWTH Aachen University, Aachen, Germany, E-Mail: jan.lux@ifas.rwth-aachen.de

Professor Dr.-Ing. Hubertus Murrenhoff

Institute for Fluid Power Drives and Controls (IFAS), RWTH Aachen University, Aachen, Germany, E-Mail: post@ifas.rwth-aachen.de

Abstract

Current efficiency measurements of variable hydraulic axial piston pumps are performed with the displacement system locked at maximum volume, thus without the controller. Therefore, the controller's effect on the efficiency is not quantified at state of the art measurements. Former research on control systems mainly focused on the dynamic behaviour. This paper aims to quantify the losses in the displacement and control system and to research the dependencies of those. Therefore, a test rig is built up at IFAS to measure the control power of displacement controlled pumps. Furthermore, a simulation tool is developed to increase the understanding of the loss mechanisms of the investigated control systems. In conclusion, the paper shows the potential of efficiency improvements for displacement controlled pumps.

KEYWORDS: displacement controlled pumps, losses, controller power, efficiency

1. Introduction

Efficiency measurements of variable hydraulic axial piston pumps are performed with the displacement system locked at maximum volume and no controller in the setup. Therefore, the controller's effect on the efficiency is not quantified at state of the art measurements. Former research on control systems mainly focused on the dynamic behaviour. Hahmann analysed the dynamics and measured the self-adjustment forces on the swash plate /1/. Drey Müller compared different control strategies and showed that a three way valve control of the control cylinder is the best compromise between loss and dynamic behaviour /2/. Electrohydraulic control systems were investigated by Langen /3/. He also showed that the flexibility of the electronic controller dominates the control behaviour of hydraulic-mechanical systems. Achten measured oscillations of the control piston pressure at the floating cup pump and indicated that a fixed swash plate during efficiency measurements does not lead to suitable results /4/.

Figure 1 shows a classification of hydraulic control methodologies into control types and power supply. Pressure controls are characterized by their simple setup. A control valve is shifted by the load pressure against a spring force and in case of internal power supply diverts power from the main line into the hydraulic displacement piston. Displacement controls typically contain an electronic controller and thus sensors and an electrically operated control valve. Similar to pressure controls power is diverted from the consumer line. In contrast to this internal power supply an additional external pump can be used represented by the second row in Figure 1. Further systems like load sensing or negative flow control are possible expansions of the aforementioned control types, but are not in the focus of this paper.

To quantify the losses caused by the controller, a test rig is built up at IFAS. Its set up and measurement results are discussed in the next paragraph. According to the results, the potential of efficiency improvements for variable displacement pumps is shown. After that, a simulation model is presented, supporting the understanding of the loss behaviour of displacement controlled pumps. Furthermore, a parameter study shows the dependence of the loss and dynamic behaviour regarding to the analysed parameters.

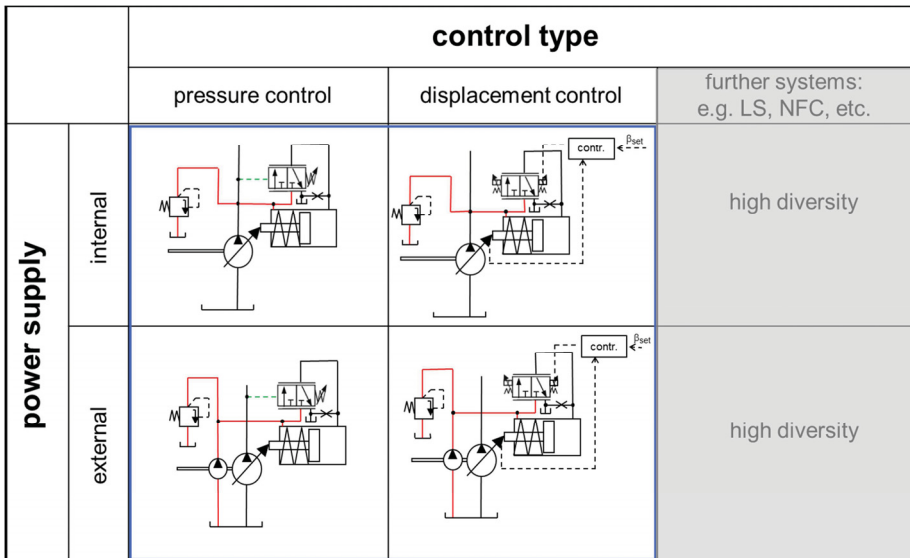

Figure 1: pump control methodology

2. Test-rig

To quantify displacement losses a test rig according to ISO 4409 /5/ is set up. A suitable measurement matrix is designed to cover the common operating points of the pump. The results are the base for further research on the dependencies and show the potential of efficiency improvements for variable displacement pumps.

2.1. Test-rig setup

The test rig is composed of a test pump driven by an electric motor delivering against a load valve. The circuit is based on a classic efficiency test bench and shown in **Figure 2**. To estimate the volumetric and hydro mechanical efficiencies of the pump, pressure, flow rate, speed and torque sensors are mounted as shown in Figure 2. To operate pressure and displacement controlled pumps, the load system of the test rig consists of two different kinds of valves. With a proportional directional valve a nominal flow rate can be set for a pressure controlled pump depending on the valve opening. To obtain a fast response of the nominal flow rate, a high performance servo valve was chosen (0% to 100% opening in 7 ms at $\Delta p = 100\text{bar}$). Using a displacement controlled pump, a pressure controlled valve sets the load of the test bench.

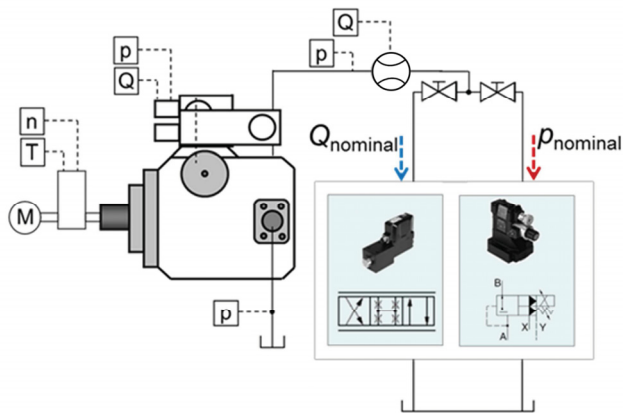

Figure 2: test rig set up

Between controller and pump a sensor block is installed, allowing the measurement of the actuator pressure (p_A) in the control piston chamber and the flow rate (Q_C) flowing through the controller (**Figure 3**). The flow rate sensor is placed in the tank line of the controller, assuring that the entire flow rate passing the controller is measured and the flow rate sensor has the lowest effect on the control behaviour.

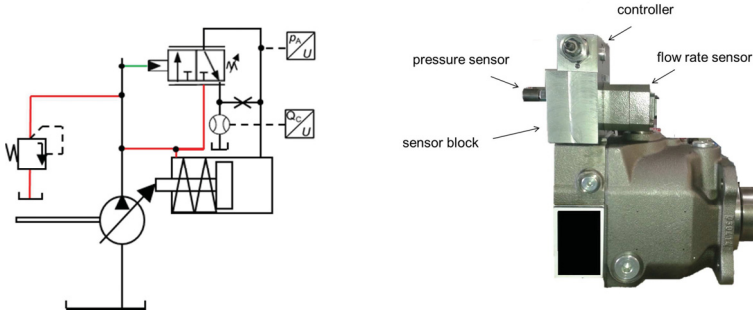

Figure 3: measuring equipment

The sensor block allows quantifying the control power beside the friction and leakage generated loss power of the pump (**Figure 4**). To identify the control power, the controller flowrate is multiplied by the supply pressure, which is the system load pressure for internally supplied controllers. The actuator pressure at the control piston is important to detect the kinematic behaviour of the swash plate and the control system.



Figure 4: variable pump power flow

The measurement matrix is created by varying the parameters displacement angle, system pressure and shaft rotational speed (**Figure 5**). To analyse the dynamic behaviour, a step answer profile for different swash plate angles is measured for all constant pressure/speed combinations shown in the matrix below.

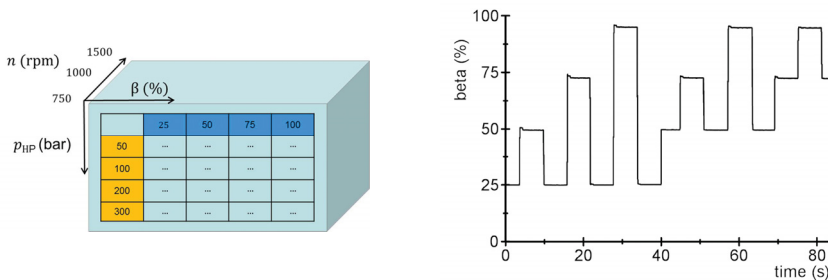

Figure 5: measurement matrix and profile

Three pressure controlled pumps from different manufactures with internal control power supply are investigated. In addition, pump A is also tested with two kinds of displacement controllers. **Figure 6** shows an overview of the tested units. The first displacement controller (dc-1) has the same hydraulic architecture as the pressure controller with a three way valve. The second displacement control option (dc-2) has a different, four way valve and, compared to the other controllers, it features no orifice between actuator pressure and tank line, which is typically used to increase the stability of the closed loop. Thus, the task is taken over by the electronic control.

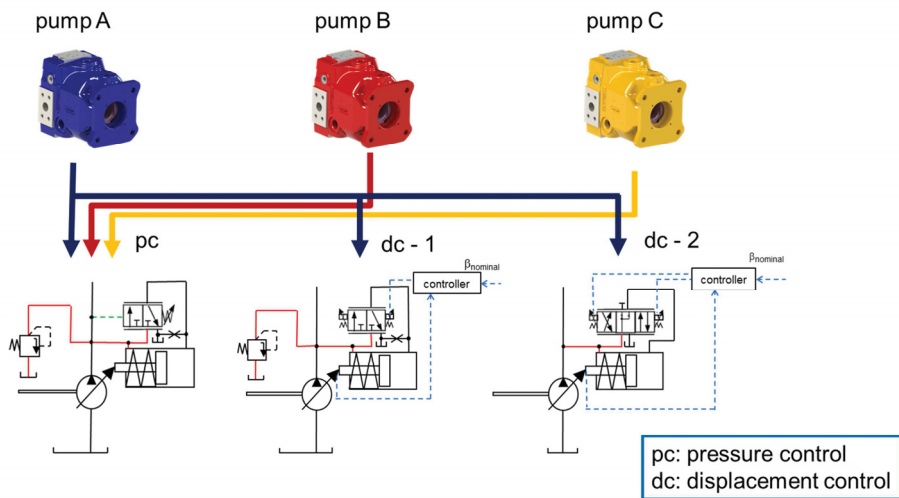

Figure 6: overview of investigated systems

2.2. Results

Figure 7 shows a measurement of pump A at $p_{HP} = 300$ bar system pressure. The mean controller flow rate ($Q_c = 3.07$ l/min) and the mean actuator pressure ($p_A = 67$ bar) are not dependent on the swash plate angle for constant system pressure. During swash plate movement the actuator pressure raises or drops according to the shift direction. The actuator pressure raises to reduce pump displacement. When the actuator pressure drops, the control piston increases the swash plate angle and pump displacement. The controller flow rate raises independently of the moving direction of the swash plate. Furthermore, the results show that the actuator pressure adjusts for all tested pumps to about 25% of the system pressure in steady state operation.

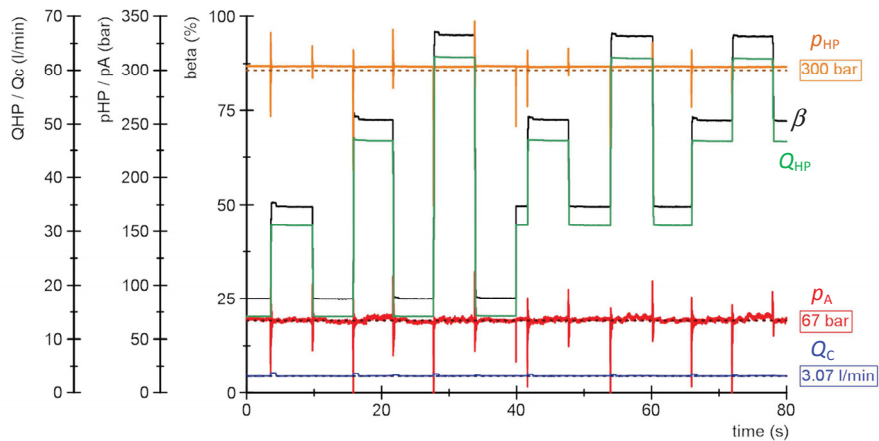

Figure 7: measurement graph for pump A at 300 bar system pressure

In the left diagram of **Figure 8** the power diverted to the control systems of the three different hydraulic axial piston pumps with internally supplied pressure controllers is shown. The control power is related to the system pressure p_{HP} . Highest recorded control power is located at 300 bar system pressure with 1.5 to 2 kW. The right diagram of Figure 8 quantifies the control power used by pump A with the three different types of controllers. The blue curve (dots) shows the control power of the pressure controlled (pc) system. Controller dc-1 (purple line, squares) needs 30% and controller dc-2 (green line, lozenges) 60% less power than the pressure controller. A hypothesis for the reduced power consumption of the both displacement controllers is based on the damping orifice diameter. In fact, the damping orifice for the dc-1 controller features a smaller diameter than for the pressure controller. The integration of an electric controller module raises the damping grade of the control system and this leads to stable controller operation with a reduced hydrostatic damping. Furthermore, the dc-2 controller has no damping orifice. This hypothesis will be proved in the following paragraph with a simulation model.

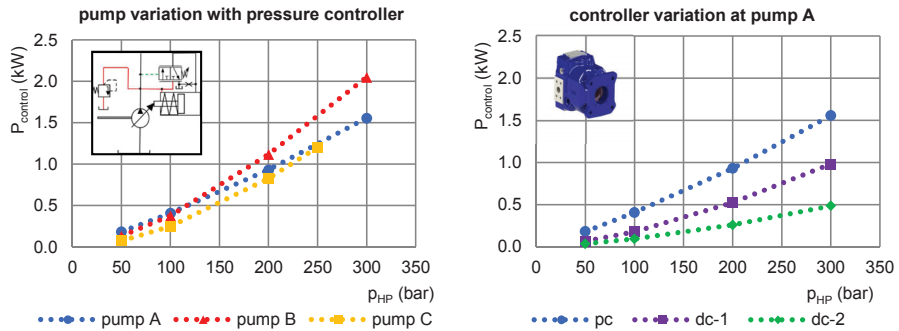

Figure 8: results for pump and controller variation

Figure 9 compares efficiency curves of pump A with pressure controller for different swash plate positions. The green line represents the results with a fixed swash plate at 100% displacement. All the other curves are measured without fixing the swash plate. The measurement shows an efficiency offset of almost 5% at 94% displacement according to the fixed swash plate with 100% displacement. With declining displacement volume the overall efficiency drops. At 25% displacement the efficiency peak is just 60%. At low pump displacements, the efficiency drops faster with raising system pressure. This supports the hypothesis that the main part of the controller losses is generated by the damping orifice. The dashed line represents the efficiency at 25% displacement without the controller power. It shows that the controller power generates 7.5% of efficiency loss in this operation point.

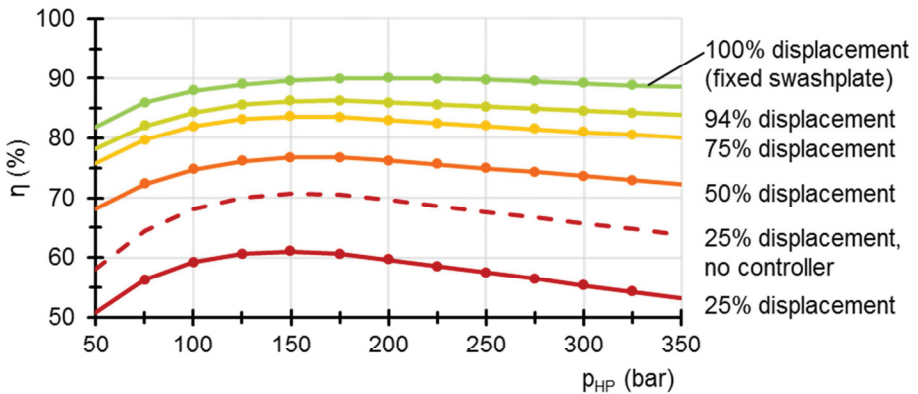

Figure 9: effect on efficiency due to controller operation

A magnification of the measured step response illustrates the dynamic behaviour of the swash plate in **Figure 10** for the pressure controller of pump A. The green line represents the position of the load valve spool to set the nominal system flow rate (Figure 2: Q_{nominal}). First, the valve spool y_{valve} is set to 10% opening which results in a 25% pump displacement set by the pressure controller for 300 bar system pressure. In the next step, the valve is opened fast to 15% opening position and the controller has to move the swash plate to 75% displacement to keep the system pressure stable at 300 bar. Therefore, the actuator pressure p_A (red line) is relieved to 0 bar during the swash plate movement. When the swash plate angle reaches the steady state, the actuator pressure raises again to the equilibrium level which is 25% of the system pressure. The opening of the control valve leads to a higher controller flow rate (blue line). The slewing back of the swash plate is shown on the right side of Figure 10. Here, the actuator pressure raises up to 120 bar before the swash plate stabilises at 25% displacement.

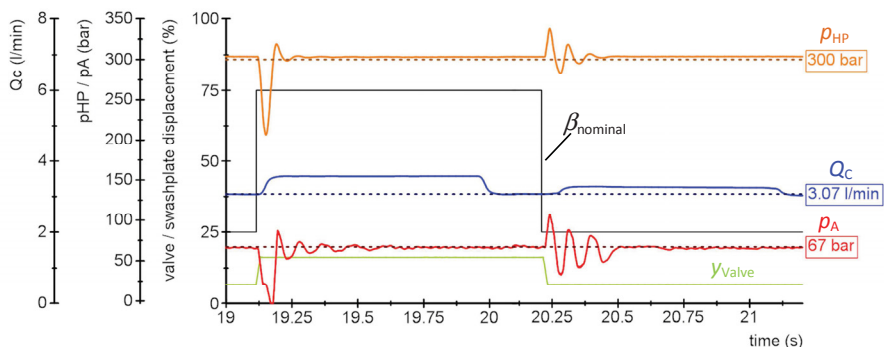

Figure 10: high resolution of step answer

In conclusion, the pressure control shows the highest potential for energy savings. Furthermore, the influence on pump efficiency grows with declining displacement angle. In contrast to the state of the art efficiency measurement, a free moving swash plate reduces the efficiency of a displacement controlled pump.

3. Simulation

To get a better understanding of the system a simulation model of the internally supplied pressure control is implemented in DSHplus, a 1-dimensional simulation environment developed for hydraulic systems.

3.1. Simulation model

Figure 11 shows the model setup. The component parameters are taken from datasheets and measurements conducted during an earlier project phase. Effects of friction and flow losses in the pipes are neglected.

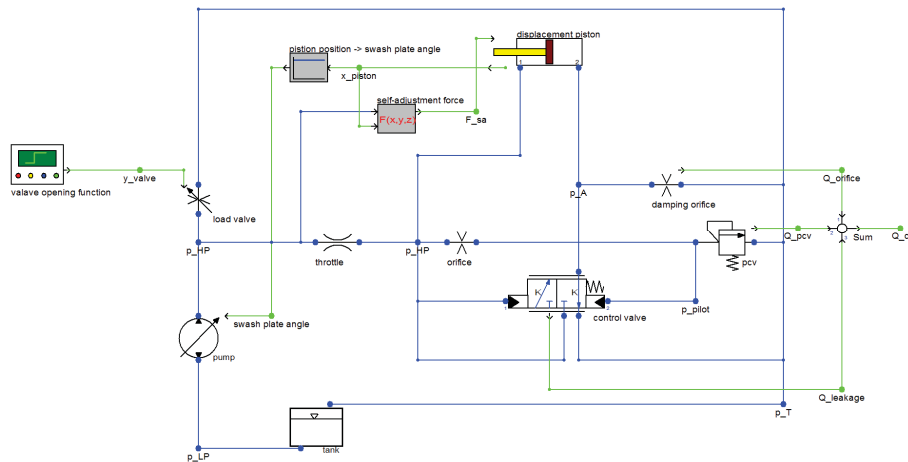

Figure 11: setup of a pressure control system in DSHplus

The model is composed of a hydraulic pump with a displacement angle input and a pressure look up table implemented in the source code. The load is modeled by a variable orifice, using the opening area as input and calculating the flow based on the pressure difference. The control valve is connected to the system pressure through a defined area and possesses a counteracting spring. Its flow is calculated from a pressure and stroke dependent look up table as well. The orifice between control valve and displacement piston – the damping orifice – acts as a stabilizer for the system. Finally the displacement piston itself has internal friction implemented as well as a spring force. Additionally the pump generates a self-adjustment force which is dependent on displacement angle and load pressure. This force can be determined by calculation of the sum of all piston forces on the swash plate. **Figure 12** shows the calculated self-adjustment forces for pump A. A negative force causes a swash plate movement to lower displacement.

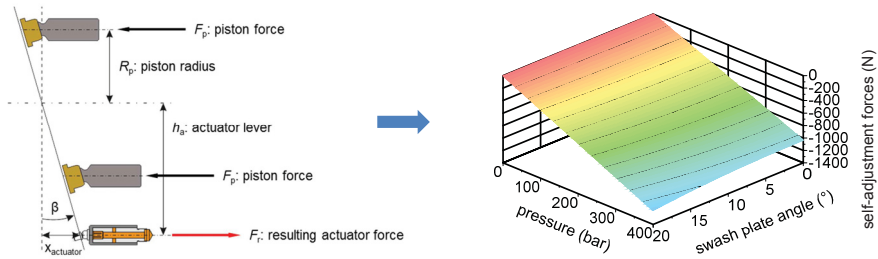

Figure 12: self-adjusting forces on the swash plate

The main output of the model is the sum of the total output flow of the controller. In combination with the controller pressure it represents the power diverted from the consumer line to displace the pump.

3.2. Simulation validation and results

The simulation is performed by the same measurement matrix presented in Figure 5. **Figure 13** shows a comparison between the simulation results and the measurement results for the controller pressure and flow. It is apparent that simulation and measurement results differ slightly, especially at 300 bar load pressure. Possible reasons may originate from the neglected flow and friction losses in the pipes. Overall, the simulation results are close to the measurements.

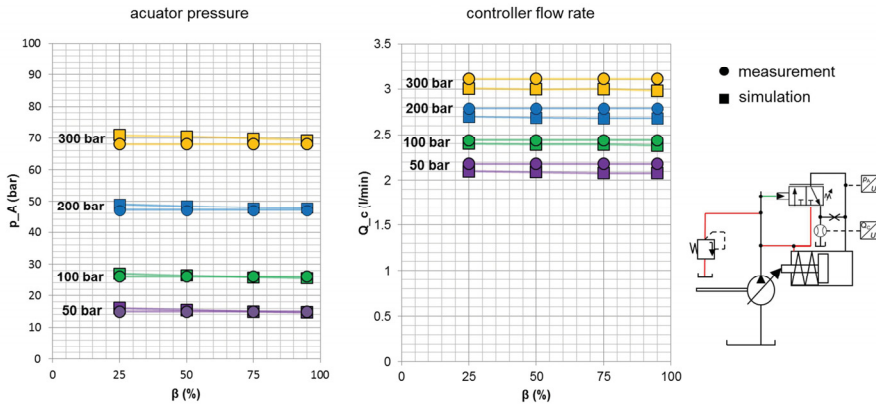

Figure 13: comparison of simulation and measurement results

Table 1 shows the results of the variation of different parameters due to losses and dynamic behaviour. It becomes obvious that upsizing of any investigated component always increases losses but also improves dynamic for the most part. It is state of the art, that pump controllers are used for different pump sizes. The controller power

remains in this case the same. Therefore, the influence of the controller power decreases with an increasing pump size. The dynamic will be reduced due to the higher self-adjustment forces.

parameter ↑	losses	dynamics
diameter of damping orifice	↑	↑
area ratio of the displacement piston	↑	↑
displacement piston diameter	↑	-
pump size	↑	↓

Table 1: influence of examined parameters on losses and dynamics

4. Conclusion and Outlook

The analyses in this paper highlight that the control power has a significant influence on the overall efficiency of displacement controlled pumps and must be considered for correct efficiency estimations of hydraulic systems. With decreasing swash plate angle, the influence of the controller power on the overall efficiency increases. The investigation shows that internally supplied pressure controlled pumps exhibit the highest potential of efficiency improvement. Main losses occur due to the damping orifice which leads to a constant leakage flow rate, as shown in the validated simulation. The electrical displacement controller can already reduce the pump controller power loss up to 60% due to the adjustable diameter of the damping orifice. The simulation model can be used to estimate efficiencies more precisely in complex system simulations. Furthermore, it supports research on more efficient controller concepts in future.

5. Acknowledgements

The IGF research project 18071 N/1 of the research association Forschungskuratorium Maschinenbau e. V. – FKM, Lyoner Straße 18, 60528 Frankfurt am Main was supported from the budget of the Federal Ministry of Economic Affairs through the AiF within the scope of a program to support industrial community research and development (IGF) based on a decision of the German Bundestag.

6. References

- /1/ Hahmann, W.: „Das dynamische Verhalten hydrostatischer Antriebe mit Servopumpe und ihr Einsatz in Regelkreisen“, Dissertation, RWTH Aachen, 1973
- /2/ Dreytmüller, J.: „Hydraulisch-mechanische Druckregelung an verstellbaren Axialkolbenpumpen“, Dissertation, RWTH Aachen, 1975
- /3/ Langen, A.: „Experimentelle und analytische Untersuchungen an vorgesteuerten hydraulisch-mechanischen und elektro-hydraulischen Pumpenregelungen“, Dissertation, RWTH Aachen, 1986
- /4/ Achten, P.: Dynamic high-frequency behaviour of the swash plate in a variable displacement axial piston pump, Journal of Systems and Control Engineering, 2013
- /5/ ISO 4409:2007 (E): Hydraulic fluid power – Positive displacement pumps, motors and integral transmissions – Methods of testing and presenting basic steady state performance, 2007

7. Nomenclature

β	swash plate angle	%
η	efficiency	%
P_c	controller power	kW
p_A	actuator pressure	bar
p_{HP}	load system pressure	bar
Q_c	controller flow rate	l/min
Q_{HP}	consumer flow rate	l/min
y_{valve}	position of load valve	%