

# High-response hydraulic linear drive with integrated motion sensor and digital valve control

**Dr.-Ing. Marko Šimic**

Faculty of mechanical engineering, University of Ljubljana, Askerceva 6, 1000 Ljubljana, Slovenia, E-mail: marko.simic@fs.uni-lj.si

**Professor Dr.-Ing. Niko Herakovič**

Faculty of mechanical engineering, University of Ljubljana, Askerceva 6, 1000 Ljubljana, Slovenia, E-mail: niko.herakovic@fs.uni-lj.si

## Abstract

Main purpose of the paper is to present high-response hydraulic linear drive, which is controlled with new digital piezo valve and where the new position transducer is integrated as a part of hydraulic cylinder. Hydraulic digital piezo valve with main static and dynamic characteristics as well as its functionality is presented in detail. The main static and dynamic characteristics of digital piezo valve which influence directly on the linear drive performance are high resolution of the volume flow rate and high response of the valve. Beside valve characteristics the new integrated position transducer, the digital controller and control method, presented in the paper, have major impact on linear drive performance. At the end of the paper the step response and position resolution of the hydraulic linear drive controlled with the new digital valve is compared with the results of reference hydraulic drive controlled with high response proportional valve.

**KEYWORDS:** hydraulic linear drive, digital piezo valve, high response, integrated motion sensor

## 1. Introduction

Advanced applications of handling and assembly which demands high dynamic positioning becomes a real challenge today [1], [2]. These applications demands high response, high position accuracy as well as low energy consumption which can be achieved with the use of high-response hydraulic linear drives controlled with new digital piezo valves [3], [4].

Most of the above mentioned industrial applications use servo hydraulic linear drives controlled with the conventional high-response proportional valves or servo valves.

Dynamic characteristics of the proportional and servo valves, even in the range of small control signals, are limited up to 200 Hz /5/, /6/. The main reason for limited dynamic response of the valve represents the valve construction and the use of conventional actuators. Optimization and development of new advanced control valves took place step by step and is mainly focused on the development of individual components of the servo valves /7/, /8/. The earlier researches are focused on the geometry optimization of the hydraulic spools in terms of mass reduction and internal flow force reduction /7/, /9/, /10/, /11/. Further on, the conventional actuators of proportional and servo valves are replaced with the high-response piezo actuators /12/, which increased the dynamic characteristics of the valves significantly (up to 600 Hz at phase shift of 90°). The step response of the valve is reduced from 7 to below 4 ms /13/.

Based on the fact that conventional servo valves with limited dynamic characteristics, high failure sensitivity and high manufacturing costs, are not always the best choice for use in high-response applications. Therefore the market demands new high-response, robust and low cost hydraulic valves which can be used as control components in modern linear drives. The use of high-response Digital Fluid Control Units (DFCU) presents one of the alternative approach /14/. With the development of new spools materials and advanced high-dynamic valve actuators, and in particular the development of advanced digital electronics and new control methods have opened up new guidelines for the development of digital hydraulic valves and linear drives. In the beginning the DFCU-s consists of several parallel connected conventional solenoid on/off seat valves. Pulse number modulation (PNM) and pulse width modulation (PWM) are the most common used control technique /15/. In the beginning the conventional low-cost switching valves were used and were not suitable for the high-response hydraulic linear drives due to low dynamic characteristics /16/. In the last decades these valves use new actuators based on piezo technology /17/ and are therefore more suitable for the use in high-response hydraulic linear drives.

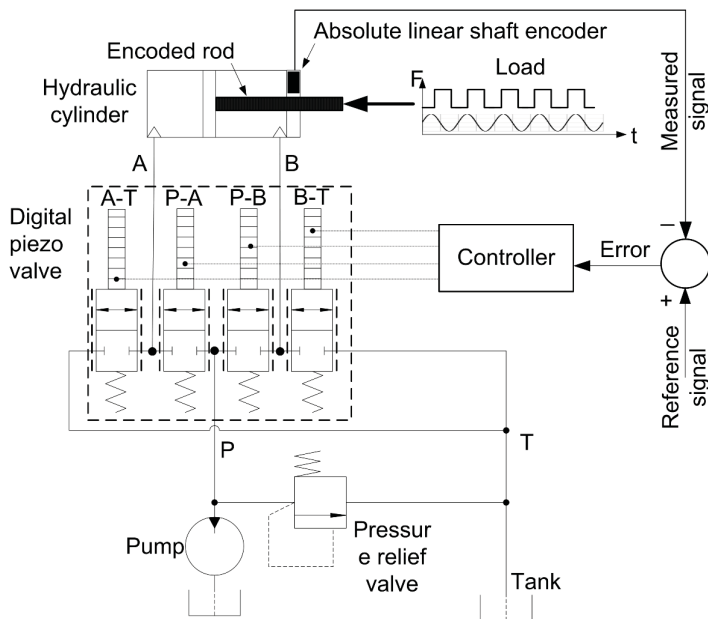
The paper deals with the high-dynamic hydraulic linear drive controlled with the new digital piezo valve. New digital electronics and control method in combination with integrated position transducer allows high response closed-loop position control.

## **2. Hydraulic linear drive controlled with digital piezo valve**

Hydraulic scheme of the linear drive where the conventional proportional valve is replaced with the new digital piezo valve shows **Figure 1**. Functionality of the 4/3 spool valve is achieved with the use of four digitally controlled on/off valves (functional states:

P-A, B-T and P-B, A-T). The major advantage of the new digital piezo valve, compared to proportional and servo valves, is the step response below 0.3 ms, even at 100% control signal. The construction of the seat valve results in robustness and has lower sensitivity to oil contamination. The advantage can be seen in control method. Control electronic and control method allows controlling the flow rate (from 0.08 to 20 l/min at pressure drop per metering edge  $\Delta p=3.5$  MPa) of individual on/off valve independently which results in high flexibility of the digital piezo valve.

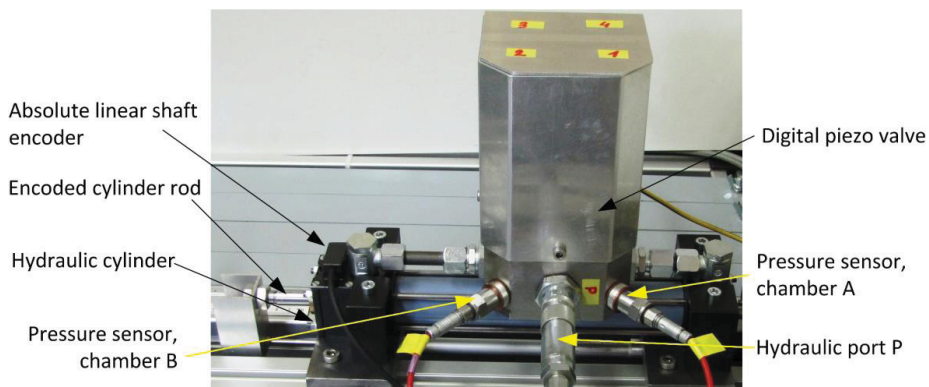
The second important component of the hydraulic linear drive presents position transducer installed directly into the hydraulic cylinder as it is shown in **Figure 1** and **Figure 2**. The position transducer consists of encoded cylinder rod and incremental absolute linear shaft encoder placed in cylinder head. Encoder with the proper electronic parameters operates with high frequency up to 4 kHz and allows measuring the cylinder rod displacement up to  $0.2 \mu\text{m}$ , which is important to perform high-dynamic and precise closed-loop position control.



**Figure 1:** Scheme of hydraulic linear drive controlled with digital piezo valve

The real picture of the prototype hydraulic linear drive shows **Figure 2**. Conventional two stage one rod hydraulic cylinder PARKER HMI ISO is used ( $D/d/s$ : 25/12/200). Digital piezo valve DPVL-20 is composed of 4 on/off seat valves which are controlled

with piezo actuators. Each piezo actuator has several piezo elements in order to achieve proper spool stroke of the valve. Control electronic and method allows controlling up to 12 piezo elements independently. Nominal flow rate of the valve is  $Q=20$  l/min at pressure drop per metering edge  $\Delta p=3.5$  MPa. Switching response time of the valve is  $t_{resp}<0.3$  ms (0-100 % control signal). Absolute linear incremental position transducer RLS LinACE™ is integrated as a part of hydraulic cylinder. The cylinder rod presents encoded shaft while the encoder is placed into the cylinder head.



**Figure 2:** Real picture of prototype linear drive controlled with digital piezo valve

## 2.1. Control method

Beside above mentioned mechanical components also the quality of the control has major influence on closed-loop position control. New control electronic and control method is specially developed for the digital piezo valve. It is based on two control methods, pulse number modulation and pulse width modulation method. It allows controlling several piezo elements placed into valves actuators totally independently. The maximal control voltage is  $U=200$  V. Block scheme of the position control method is presented in **Figure 3**.

Micro controller is used to perform the PID closed-loop position control. The actual and real cylinder position is compared and the position error is calculated which presents the input parameter of the control method. The position error is amplified ( $e_{oj}$ ) and the proper valves (V1, V3 – for the positive error and V2, V4 – for the negative error) are activated based on negative or positive error. Further on, the method defines the number of activated piezo elements of the active valve actuators. If the error is big the valve is totally opened (all piezo elements of the actuator are activated) and if the error is small only one piezo element of the actuator is activated. After the number of piezo

elements is defined the parameters of PWM method is calculated (generation of PWM signal) for two signals (ON - PWM signal for piezo element activation and OFF - PWM signal for piezo element deactivation). The minimal time period of PWM signal is limited to  $t=10 \mu\text{s}$ . Closed-loop control is performed with the frequency up to 4 kHz (compatible with the position transducer frequency).

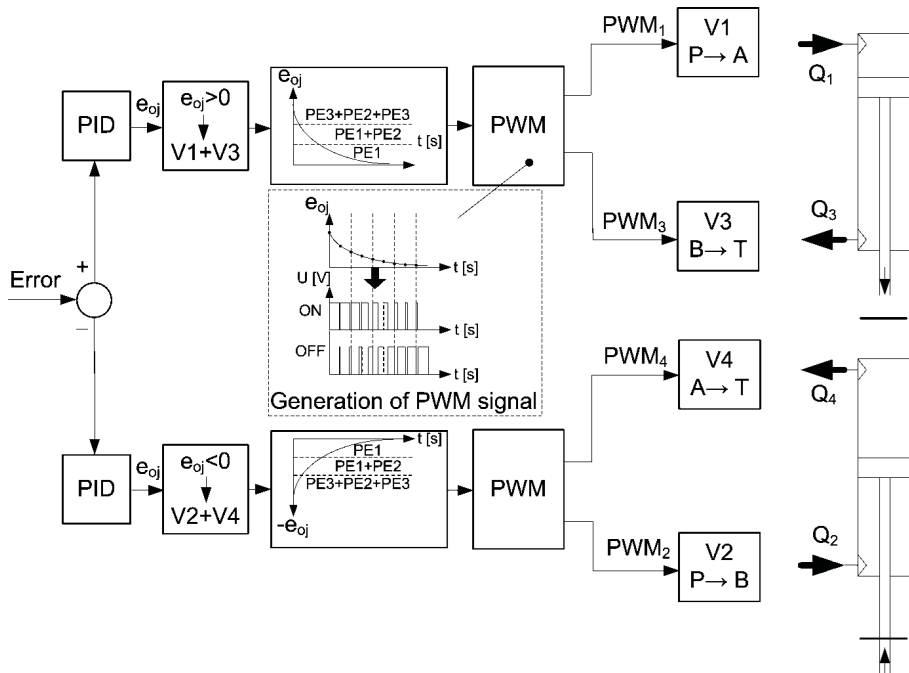
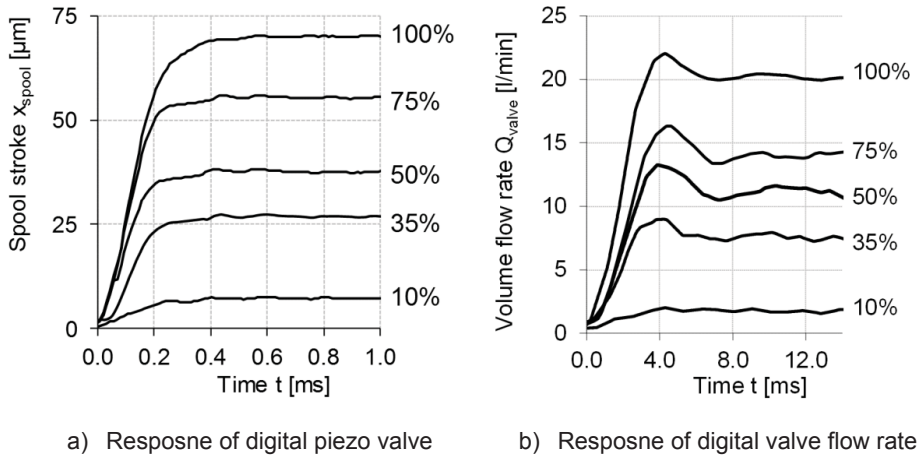


Figure 3: Block diagram of control method

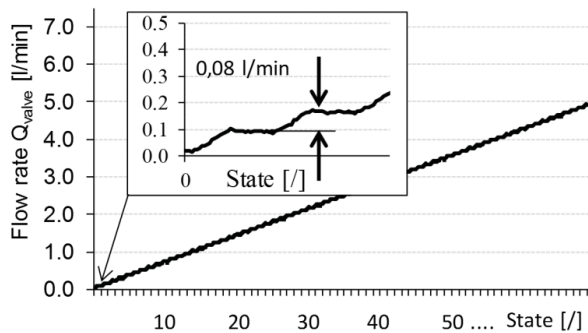
### 3. Experimental investigation of digital piezo valve and hydraulic linear drive

Dynamic characteristics of the hydraulic linear drive depend on characteristics of the control components (hydraulic valve). Therefore the main valve characteristics are presented first followed with the dynamic characteristics of the linear drive. The step response of the digital piezo valve for different control signals is shown in **Figure 4a** and **Figure 4b**. Measured step response gives the response time below 0.3 ms (spool movement from initial position to 100% position), while the step response of the valve flow rate at hydraulic port A is around  $t=2$  ms.

By using the proper control method the minimal step size of flow rate is around 0.08 l/min which results in flow rate characteristic close to linear (**Figure 5**).

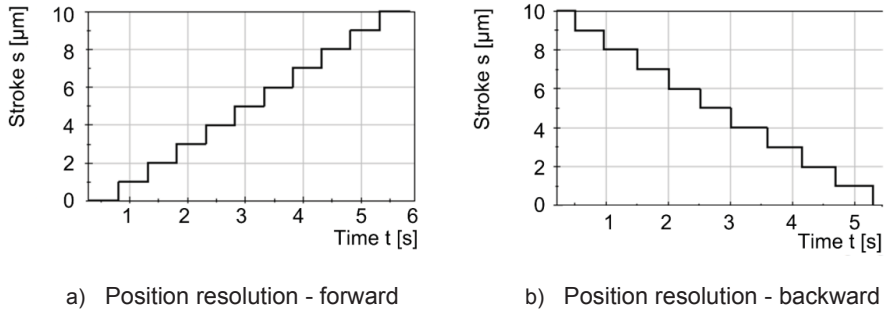


**Figure 4:** Characteristics of digital piezo valve



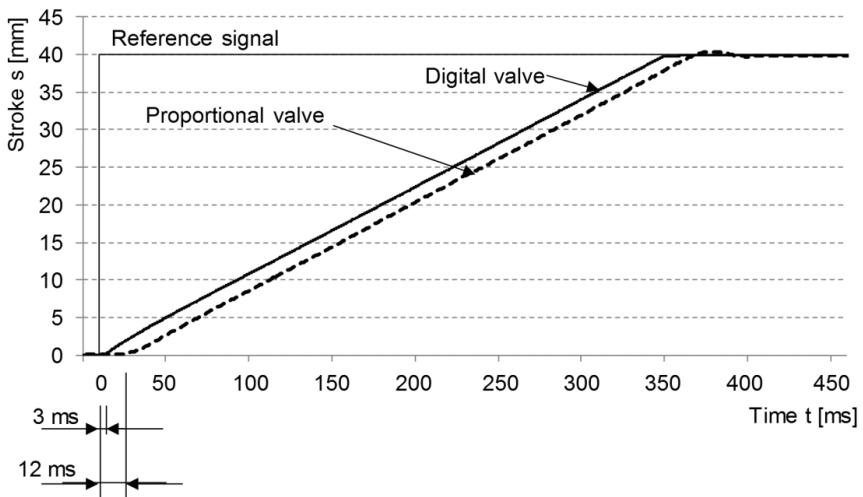
**Figure 5:** Flow rate characteristics of on/off piezo valve and the step size (state P→A)

The results of the experimental tests for hydraulic linear drive are presented in **Figure 6** and **Figure 7**. **Figure 6** shows the position resolution of the hydraulic linear drive. The position resolution is depended directly on the valve flow rate resolution. By using the digital piezo valve and the proper control method we are able to control the position of the hydraulic drive up to 1  $\mu\text{m}$  in both directions, forward and backward (**Figure 6a and b**). The control method and the parameters should be set separately for forward and backward direction due to unsymmetrical hydraulic cylinder chambers.



**Figure 6:** Step response of hydraulic linear drive controlled with proportional and digital valve

The test of dynamic step response involves two different control valves; high-response proportional valve Moog D633 as a reference and new digital piezo valve. The step response curves are measured at inlet pressure  $p=6$  MPa. The black dotted curve shows the step response of the linear drive controlled with proportional valve while the solid curve shows the step response of the linear drive controlled with digital piezo valve. It can be seen that linear drive controlled with digital piezo valve has much lower time delay at the beginning and determines higher stiffness of the hydraulic system which can be seen as smaller overshoot. To confirm the influence of new digital piezo valve on the dynamic characteristics of the linear drive deeper analysis and optimization processes will be performed in the future research work.



**Figure 6:** Step response of hydraulic linear drive controlled with proportional and digital valve

#### 4. Conclusions

In this paper high-response hydraulic linear drive controlled with new digital piezo valve and integrated position transducer is presented. The research work is focused on the possibility of replacing the conventional proportional or servo valves with the new digital piezo valves. One of the main components that influence directly on dynamic characteristics of the linear drive and low energy consumption present high-response digital hydraulic piezo valve. Static characteristics as well as dynamic characteristics of the hydraulic valve and linear drive show that the use of new digital piezo valve is sufficient. The use of advanced piezo actuators in hydraulic on/off valves and its mechanical construction results in better step response. The response time of the valve is reduced to 0.3 ms while the response time of the linear drive is reduced to 3-4 ms. Proper control electronics and control method also have major impact on dynamic characteristics of the linear drive. Combination of PNM and PWM methods results in high resolution flow rate of the valve and therefore flow rate characteristics close to linear. In this way the number of on/off valves in DFCU unit is reduced. First results of the energy consumption measurement tests, which will be analysed in detail in the future, shows that the use of piezo actuators can reduce the energy consumption up to 15% compared with the conventional high-response proportional valve Moog D633 of the same size.

The future research work is focused on further experimental analysis and characterization of the hydraulic linear drive (disturbance response, position resolution of the linear drive, etc.).

#### 5. References

- /1/ Esposito, A. Fluid Power with applications: International fifth edition. Miami University, Oxford, Ohio, Department of Manufacturing Engineering, 2000
- /2/ Bower, J. Digital Fluid Control System. US Patent No. 2999482, 1961
- /3/ Motohiro, K., Hitoshi I., Makoto I., Hiromu H. Fast-response and high-precision positioning using iterative learning control. Department of Electrical and Computer Engineering, International Journal of Applied Electromagnetics and Mechanics, 2007
- /4/ Herakovič, N. *Mechatronische Systeme in der Ventilentwicklung. Int. j. autom. Austria, 2007, letn. 15, št. 1, str. 43-52*



- /5/ Uusi-Heikkilä J. IHA-Intelligent Hydraulics and Automation [online]. Finland: Tampere University of Technology, [view at the time 10.10.2011]. Available on: <http://www.iha.tut.fi/research/digihydraulics/>
- /6/ Johannes Kepler University Linz. Austria. Institute of Machine Design and Hydraulic Drives. [view at the time 11.10.2011]. Available on: <http://imh.jku.at/research/index.en.php>
- /7/ Institute for Fluid Power Drives and Controls (IFAS). RWTH Aachen. [view at the time 11.10.2011]. Available on: [http://www.ifas.rwth-aachen.de/index\\_e.php](http://www.ifas.rwth-aachen.de/index_e.php)
- /8/ Centre for Power Transmission and motion control. United Kingdom: University of Bath. [view at the time 11.10.2011]. Available on: <http://www.bath.ac.uk/ptmc/research/index.html>
- /9/ Herakovič, N. Die Untersuchung der Nutzung des Piezoeffektes zur Ansteuerung fluidtechnischer Ventile. Der Fakultät für Maschinenwesen der Rheinisch-Westfälischen Technischen Hochschule Aachen vorgelegte Dissertation zur Erlangung des akademischen Grades eines Doktors der Ingenieurwissenschaften. Aachen: [N. Herakovič], 1995. IV, 152 f., illustr
- /10/ Herakovič, N. Flow-force analysis in a hydraulic sliding-spool valve. *Strojstvo*, 2007, letn. 49, št. 3, str. 117-126
- /11/ Herakovič, N. Zmanjševanje krmilnih sil v hidravličnih ventilih = The reduction of control forces in hydraulic valves. *Ventil (Ljubl.)*, 2001, letn. 7, št. 4, str. 214-217
- /12/ Reichert, M., Murrenhoff H. *New Concepts and Design of High Response Hydraulic Valves Using Piezo-Technology*. Institute for Fluid Power Drives and Controls, RWTH Aachen University, Germany, 2010
- /13/ Reichert, M. Development of High-Response Piezo-Servovalves for Improved Performance of Electrohydraulic Cylinder Drives. Von der Fakultät für Maschinenwesen der Rheinisch-Westfälischen Technischen Hochschule Aachen zur Erlangung des akademischen Grades eines Doktors der Ingenieurwissenschaften genehmigte Dissertation, 04.02.2010

- /14/ Linjama, M., Laamanen, A. & Vilenius, M. *Is it time for digital hydraulics? Proceedings of the Eighth Scandinavian International Conference on Fluid Power, May 7–9, 2003, Tampere, Finland, pp. 347–366*
- /15/ Linjama, M. Energy saving digital hydraulics. In Proc. Of The Second Workshop on Digital Fluid Power, DFP' 09, stran 5-20, Linz, Avstrija, 12-13 November 2009
- /16/ Uusitalo, J. P. A novel Digital Hydraulic Valve package: A fast and Small Multiphysics Design. Thesis for the degree of doctor of Science in Technology, Tampere university of technology, Publication 912, 30th of Septemeber 2010
- /17/ Prof. Dr.-Ing. Hubertus Murrenhoff. *Trends in Valve Development. Institute for Fluid Power Drives and Controls (IFAS), RWTH Aachen, O + P »Ölhydraulik und Pneumatik« 46 Nr. 4 (2003)*

## 6. Nomenclature

$d$	Cylinder rod diameter	m
$D$	Cylinder piston diameter	m
$e_{oj}$	Amplified position error	m
$Q$	Nominal volume flow rate of the valve	l/min
$s$	Cylinder stroke	m
$t_{resp}$	Time step response of the valve	s
$U$	Control voltage	V
$\Delta p$	Pressure drop per metering edge	MPa