

Naval War College Review

Volume 53
Number 2 *Spring*

Article 7

2000

The Politics of Extravagance: The Aircraft Nuclear Propulsion Project

Carolyn C. James

Follow this and additional works at: <https://digital-commons.usnwc.edu/nwc-review>

Recommended Citation

James, Carolyn C. (2000) "The Politics of Extravagance: The Aircraft Nuclear Propulsion Project," *Naval War College Review*: Vol. 53 : No. 2 , Article 7.

Available at: <https://digital-commons.usnwc.edu/nwc-review/vol53/iss2/7>

This Article is brought to you for free and open access by the Journals at U.S. Naval War College Digital Commons. It has been accepted for inclusion in Naval War College Review by an authorized editor of U.S. Naval War College Digital Commons. For more information, please contact repository.inquiries@usnwc.edu.

The Politics of Extravagance

The Aircraft Nuclear Propulsion Project

Carolyn C. James

HOW DID THE U.S. NAVY GET INVOLVED in a ponderous, pricey, and ultimately pathetic effort to achieve nuclear-powered flight? The Navy was the post-World War II leader in supporting research for technological innovations intended to strengthen U.S. military might;¹ the Aircraft Nuclear Propulsion Project (ANP), however, is one instance in which it would have been better not to have been involved at all. Unfortunately, the story that will be told here—one of interservice rivalry over appropriations—has a familiar ring. Some might prefer that this seemingly lost chapter in naval history remain in dusty boxes at government archives; as will become apparent, it does not place its principals in a very positive light. It is important, however, that this story be remembered and retold. In the post-Goldwater-Nichols spirit of reducing interservice conflict, lessons can be drawn from proposals based as much (or more) on jealousy as on prudence, and from ideas more fantastic than feasible. This is true even when the events at issue are several decades old; as the saying goes, those who forget the past may end up reliving it.

The ANP project, a manifestation of the American push for innovation in aviation technology, now seems like a figment of the Cold War imagination.² The nuclear jet, originally envisioned by the Air Force, was to be capable of extremely long-term, continuous flight without refueling. The program, which commenced under the Joint Committee on Atomic Energy (JCAE) and the Lexington Project of the Atomic Energy Commission (AEC), located at the Massachusetts Institute of Technology, ballooned into a massive research and development effort. The ANP project spanned almost fifteen years,

© 2000 by Carolyn C. James

Naval War College Review, Spring 2000, Vol. LIII, No. 2

included about two dozen governmental and private institutions, and consumed over a billion dollars (in 1950s currency). The ANP ultimately failed: no aircraft of practical value that used a nuclear reactor for its power plant ever materialized. The final decision to scrap the project reflected more concern about cost and negative public opinion than about feasibility—a feasibility that may be judged by the fact that even today, and for the foreseeable future, nuclear-powered aircraft remain technically possible but too problematic, along several dimensions, to be realized.

This article begins, after placing the ANP project in historical context, by explaining the technological obstacles it had to overcome before atomic flight could have been realized. By the early 1950s the project was still highly debated but had matured into a complex research and development effort; a chronicle of the Navy's role, beginning in this period, follows. As will next be seen, the project would fall victim to rising costs, competing weapons systems, and ultimately the fears that often accompany the use of nuclear energy. The article concludes with a brief review of the project as well as of its aftereffects.

On 8 August 1945, as a world torn by six years of conflict considered the prospects of peace and rebuilding, the commander in chief of American military forces looked ahead to the nation's future security needs. Although the predictions of General Giulio Douhet, the early-twentieth-century aviation theoretician, about the social impact of strategic bombing had not fully materialized, it was clear that airpower had become a key component of national defense.³ A memo from President Harry Truman to Henry Stimson, the secretary of war, drew attention to the importance of aircraft development. "It is vital to the welfare of our people," Truman emphasized, "that this nation maintain developmental work and the nucleus of a producing aircraft industry capable of rapid expansion to keep the peace and meet any emergency." In particular, the United States would need an "adequate number of advanced and developmental aircraft."⁴ These assertions, which undoubtedly reflected even earlier conclusions about the need to keep ahead of the Soviet Union, provided legitimacy to even the most revolutionary thinking in aviation at the time, including such ideas as atomic power for aircraft—a concept that

160 Naval War College Review

followed quickly on the heels of the awesome events at Hiroshima and Nagasaki.

While the idea of nuclear-powered aircraft may seem almost ludicrous today, in the years immediately after World War II it appeared both feasible and desirable.⁵ For many informed observers, scientific advancement had become identified with the early end to the war with Japan brought by the atomic bomb.⁶ Atomic energy, then in its nascence, held an almost mystical promise of technological leaps to a safer, less complicated world.⁷ In particular, the atom also became the focus of postwar security thinking; both elite and mass opinion quickly perceived a need to stay ahead of other states in development of weapons based on that technology. It is necessary to recall as well that the environmental concerns so dominant in nuclear issues today were not as significant at that time.

When the Cold War intensified and the United States began to contemplate armed conflict with the Soviet Union, ANP offered many advantages. National security seemed to have become increasingly a matter of threatening atomic retaliation. The one means of delivery then available, however, was strategic bombers, whose reach was limited.⁸ In order to protect the nation and its overseas allies, as well as threaten the Soviet Union, the United States depended accordingly upon several costly foreign bases. A nuclear power plant, if it achieved operational capability, would keep an

Carolyn C. James is a Visiting Research Scientist with the International Institute of Theoretical and Applied Physics (IITAP) at the Iowa State University of Science and Technology. Trained in political science, Professor James is a specialist in nuclear weapons policy, both acquisition and strategy. Her research includes the role of nuclear scientists and engineers in civil-military relations, crisis decision-making in nuclear-capable states, and the proliferation of weapons of mass destruction. Recent publications include "Iran and Iraq as Rational Crisis Actors: Dangers and Dynamics of Survivable Nuclear War," *Journal of Strategic Studies*, March 2000, and "Security Policy at the Dawn of the Nuclear Age: The Case of the Aircraft Nuclear Propulsion Project," in *Handbook of Global International Policy*, ed. Stuart Nagel (New York: Marcel Dekker, 2000).

Professor James would like to acknowledge the generous support of IITAP, the Eisenhower World Affairs Institute, and the Kennedy Presidential Library.

aircraft armed with atomic warheads aloft for days at a time. Thus ANP promised to endow the United States with a constantly airborne atomic capability that depended only on military installations at home. U.S. bases in other countries could be reduced to the political and logistical functions of forward presence.⁹

Like that of most states after a war, the U.S. mind-set favored demobilization. This widely held attitude created a difficult cross-pressure for decision makers: they had to ensure security while responding to a public eager for the return of normal conditions and, especially, peacetime prosperity. Here was another attraction of ANP: while it might require a substantial investment up front, it could be justified as a means to save enormous amounts of money in the long term through reduction in infrastructure.

The role envisioned for ANP, as just described, fit perfectly into the mission of the U.S. Air Force. The Navy, however, as it had with many nuclear issues, became interested in this piece of the atomic "pie." Interservice rivalry motivated a considerable effort on the part of the Navy to possess an atomic-powered aircraft suitable to its own mission requirements, especially antisubmarine warfare. As will be seen below, this desire accounted for a respectable percentage of the overall time, effort, and funding spent on the ANP.

In sum, the project had appeal in terms of the need to beat the USSR to technological breakthroughs and of the possibility of a strategic deterrent that did not need foreign bases or otherwise depend on an American ability to ensure free passage of the world's oceans. The quest for aircraft nuclear propulsion, at least at its outset, made sense for the United States in the era of a building rivalry with communist states and related tensions at home.

From Idea to Research and Development

Support for aircraft nuclear propulsion started in the military. Even before the end of World War II, Colonel Donald J. Keirn, an Army Air Corps power-plant specialist serving at Wright Field in Dayton, Ohio, who had long been interested in state-of-the-art aviation technology, initiated discussions about nuclear propulsion.¹⁰

Concerns about the connection between future security and progress in aircraft technology reached the cabinet level in December 1945, in the form of a proposal sent by the Engineering Division of

162 Naval War College Review

the Air Technical Service Command to the Department of War. This document, which specifically made a case for an Air Engineering Development Center, put a premium on planning ahead: "Our immediate planning for future development and development facilities must be projected far beyond the possibilities known today." The proposal also argued that nuclear propulsion of aircraft should have the same priority as nuclear weapons research: "It is equally important to develop nuclear energy as a propulsive means and, with nuclear propulsion, supersonic flight around the world becomes an immediate possibility. Special consideration should be given to a system whereby nuclear energy would first be used for propulsion to the target and then the nuclear matter detonated as an atom bomb."¹¹

Further military support for research, implicitly endorsing in advance such projects such as the ANP, came from a statement by Rear Admiral P. F. Lee, the Chief of Naval Research, to the President's Air Policy Commission (known as the APC) in March 1946. Lee asserted that "the Federal Government must support basic research on a greatly increased scale. To a large measure the security of this country is dependent on our scientific resources." Furthermore, aircraft would be at the top of the list, at least from the Navy's point of view: "Over one-half of the funds requested by the Navy for research and development facilities for Fiscal Year 1949 have been set aside for aeronautical research and development facilities."¹² Taken together, these assertions by high-ranking military officers make it clear in retrospect that innovative aircraft-related projects could expect a sympathetic ear from the services.

Aircraft nuclear power became an official research project in May 1946, when the Army Air Forces awarded to the Fairchild Engine and Airplane Corporation a contract to perform preliminary studies on a manned, nuclear-propelled airplane.¹³ The project, which Fairchild was required to conduct at Oak Ridge National Laboratory in Tennessee, effectively represented a proposal for more extensive work, which would include development and even flight testing of aircraft.

The problems inherent in aircraft nuclear propulsion were numerous; some of the greatest challenges were in reactor development. In particular, aircraft nuclear propulsion required a reactor much more compact than available under current technology. No airframe could carry a reactor of then-normal dimensions. To be small and light

enough to be used in an airplane, a reactor would have to release more heat energy—some 500 percent more—than did the first submarine reactor. Confined to a small space, the extremely hot reactor might even melt itself, unless more resistant materials also could be developed. Furthermore, the reactor would require more efficient shielding to protect the crew from deadly radiation; land-based reactors at the time usually were protected by six feet of concrete. All of these considerations could be rolled up in terms of “power loading,” pounds of vehicle weight per horsepower; on that practical scale, the *Nautilus* nuclear-powered submarine measured more than 150, while a supersonic bomber would have to be closer to four.¹⁴

Two basic approaches to nuclear propulsion that received sustained attention during the Fairchild project were known as direct and indirect cycles. The brief technical summary that follows will give some sense of the difficulty (see Figure 1) of the issues involved:

In the direct cycle, air enters through the compressor, is forced into the reactor, and is heated by the fuel elements. After passing through the turbine, where energy is extracted to drive the compressor, the heated air is expelled at high velocity through the exhaust nozzle. In the indirect cycle, the heat generated in the reactor is absorbed by a liquid-metal coolant flowing through the reactor core. The liquid-metal coolant then flows through an intermediate heat exchanger where the heat is transferred to a secondary loop. The hot liquid-metal is then pumped to the jet engine. The jet engine contains radiators, where the heat is given up by the liquid-metal and imparted to the air-stream flowing through the engine. Thus, the air is heated directly by the reactor in the direct cycle as contrasted with being heated indirectly by the reactor in the indirect cycle.¹⁵

Few scientists and engineers at that time were qualified even to begin to make well-informed judgments about which system would better fulfill future mission requirements.

At the outset, however, it became apparent that each system had a basic advantage that was accessible to a general audience. The direct cycle would be simpler to develop. As implied by its name, a direct-cycle reactor supplies a turbine with heated air flowing directly from the reactor core. In this respect the technological barriers

Figure 1
Indirect Reactor Cycle

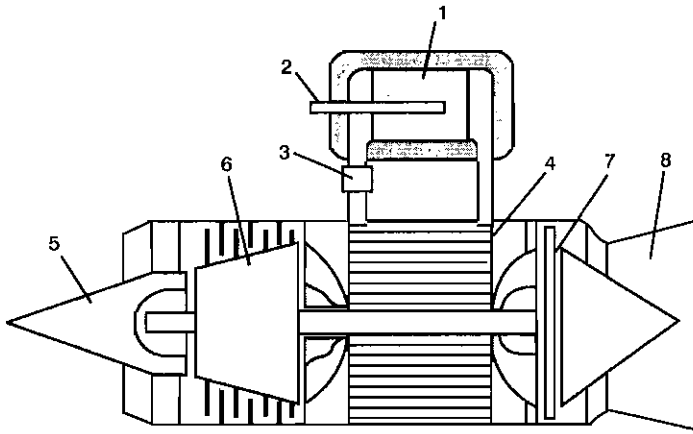

Schematic of an atomic turbojet engine with liquid-metal heat exchanger:
1. reactor; 2. control rod; 3. liquid-metal pump; 4. heat exchanger;
5. inlet cone; 6. compressor; 7. exhaust turbine; 8. jet nozzle.

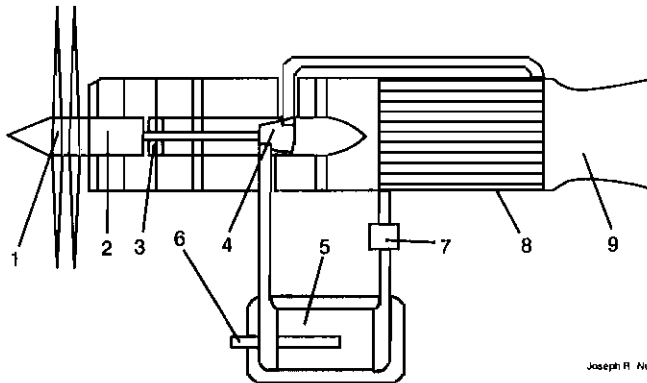

Joseph R. Nunes Jr.

Schematic of an atomic turboprop engine with mercury turbine:
1. propellers; 2. reduction gear; 3. air compressor; 4. mercury turbine;
5. reactor; 6. control rod; 7. Mercury pump; 8. condenser; 9. jet nozzle.

Yu. N. Sushkov, "Atomic Energy in Aviation,"

would be fewer and simpler, and an atomic-powered jet seemed likely to become airborne sooner. However, the indirect-cycle approach, though more complex, promised to result ultimately in a smaller reactor.¹⁶ If a direct-cycle program could not develop a system that was compact enough, it might prove a dead end. Only time and effort could answer the question of which system would be better in an overall sense. Unfortunately, in the end, even the fifteen years that the project lasted were not enough; both systems continued to be researched throughout the ANP's lifetime.

The reactor was not the only component requiring extensive research. Much of the weight came from reactor shielding, and compactness here would be especially critical. Ceramic materials would become one of the important avenues of research. Two ways were proposed to shield the airframe, the unit shield and the divided shield. The unit shield, which would surround the reactor itself, would provide the greatest reduction in radiation exposure for the crew and aircraft components. Unfortunately, it would also be the heavier option, which would trade off against the desire for high speed. A divided shield would split the shielding between the reactor and the crew compartment. Weight in the nose would increase, which was a particular concern, because as will be seen, the ANP airframe was often conceptualized as a seaplane, which would need to be able to land on rough seas. In addition, increased leakage of radiation into the components of the plane would reduce reliability, increase maintenance requirements, and shorten the life of the aircraft. The more susceptible organic materials, such as rubber, hydraulic oil, and lubricants, would need to be replaced with inorganic substances or with entirely new systems that did not require organic materials.¹⁷

From the outset there were skeptics about ANP, mostly in the scientific community. For example, when asked by Keirn in July 1945 about aircraft nuclear propulsion, Vannevar Bush, then director of the Office of Scientific Research and Development, replied that "the idea was a bad one" and told him to "forget it."¹⁸ In 1948, J. Robert Oppenheimer and James B. Conant (both advisors to the AEC) asserted that although the aircraft could be developed, the technological barriers were too immense to make the endeavor cost-effective.¹⁹ However, it was to be more explicit and favorable reports from outside both the military and private industry that commanded the

166 Naval War College Review

attention of key decision makers. The APC produced a report, *Survival in the Air Age*, that included a dramatic statement in favor of aircraft nuclear propulsion:

The possibility of employing atomic energy for the propulsion of aircraft and guided missiles is sufficiently important to warrant vigorous action by the Atomic Energy Commission, the Air Force, the Navy, and the NACA.²⁰ Some work of a preliminary nature already has been done in this field by the AEC, the Air Force and its NEPA project. Immediate steps should be taken to intensify research effort in this field under a plan that would be supported by all of the above agencies and under which the project would be given the benefit of all the background information in the atomic field actually needed by the recipients for the appropriate performance of their respective functions.²¹

Tensions with the Soviet Union were growing, and arguments in favor of high-technology research and development programs found few critics. The APC report encountered no opposition, and it gave the idea of a long-term development effort for nuclear propulsion enhanced legitimacy.

ANP also got a major break from elsewhere within the Byzantine system of national security advising. A report submitted in September 1948 at the request of the AEC by a team of leading scientists had considerable and generally favorable implications for the ANP project. The AEC had requested a group of forty nongovernmental scientists at MIT to determine the overall feasibility of the project. Headed by Prof. Walter G. Whitman, chairman of MIT's Department of Chemical Engineering, the "Lexington Project" concluded that success would require the development of improved metals and more potent chemical fuels. The Lexington team found ANP was possible but warned that it would probably cost upward of a billion dollars and take as long as fifteen years.²² While the price tag might have seemed high, it mattered more that this distinguished group of scientists had concluded that the thing could be done. The possibility was all the more important because at this point no alternative to long-range manned aircraft, such as intercontinental-range missiles, seemed practical.

In the four years after Truman expressed interest in the idea of improved aircraft technology, then, work on ANP generally met with

approval or at least tacit acceptance. The phase of advising and consultation drew to a close at the outset of 1951, and the relevant agencies—at the time, the AEC and the Air Force—moved the project toward basic research as a preliminary to applied research and development. The cost, thus far, had reached twenty-one million dollars.²³ Preliminary proposals for ANP were ready by February 1951, at which time the research and development went into full swing for a nuclear airplane that would be supersonic and achieve operational status in the early 1960s.

The Navy Tries to Get on Board

You've got to realize, when I went to Washington in '54, there were no missiles. There was no aircraft that could fly the speed of sound. There was no atomic power. There was certainly no satellite. The whole thing came, all of a sudden, bunched in there. It came within five or six years—five or six years.

—Thomas S. Gates, Jr., Secretary of Defense²⁴

The Navy involved itself in aircraft nuclear power as early as the spring of 1949, when its representatives served on an ad hoc steering committee formed to provide guidance to the program. As the rivalry that then arose played itself out, serendipity intervened, producing events in and outside of government favorable to the ANP.

Interservice rivalry over aircraft nuclear power came into the open in late 1953, even though the Navy and Air Force had begun to work together as early as 1949 in what seemed a cooperative and promising way. In May of that year, the Navy transferred \$1.5 million to the Air Force for ANP research;²⁵ it also assigned personnel to now-General Keirn's staff at the Aircraft Reactors Branch of the AEC. According to an agreement between General Keirn and Rear Admiral James S. Russell, former chief of the Bureau of Aeronautics, the Navy's interest would be limited to keeping track of ANP advances in case any developments could be used by the Navy as well; "Navy participation was not to generate into a competition to fly first."²⁶ In August the Navy informed the AEC that it was interested in a low-power reactor for a subsonic seaplane. At that point in time, its "interest" was restricted to gathering data in order to assess possible mission applications.

168 Naval War College Review

During the same month, as part of that effort, the Navy awarded study contracts to seaplane builders and reactor consultants to “assess the significance of nuclear power for aircraft design.”²⁷ Navy spokesmen argued that a jet with the remarkable endurance envisioned—the figure of a thousand hours was commonly used—would be better suited to antisubmarine warfare than to long-range strike. Flying close to the ocean surface, it would be able to conduct thorough sweeps of vast areas in remote locations. Because a supersonic, high-altitude ANP aircraft did not seem to be around the corner by any means, a low-flying plane, traveling at subsonic speed, made sense in developmental terms; also, ANP might be more easily justified in the context of naval operations than that of strategic action against the Soviet homeland.

Perhaps seeing merit—and therefore danger—in the Navy’s case, the Air Force responded in the second half of 1953; General Curtis E. LeMay of the Strategic Air Command took the lead, though his earlier interest in ANP had been minimal.²⁸ The Air Force reemphasized the advantages of thousand-hour-endurance strategic bombers, which would not require in-flight refueling. Such an aircraft, based safely in the United States, could strike targets missed by an attack by conventional long-range bombers or intercontinental ballistic missiles (which by 1953 appeared a promising prospect). The value of such a capability, in comparison to some tactical advantage in anti-submarine warfare, argued against any diversion of constrained Eisenhower-era budget resources from the Air Force to the Navy. On the strength of this rationale, the Air Force had reason to believe that it would hold the long-term advantage in any power struggle with the Navy over ANP.

Significant disagreements existed over the design of the proposed jet, its purpose, and which service would control it. The first airframe proposed by the Navy, in 1956, was based on the Martin P6M-1 Seamaster, built by the Glenn L. Martin Company of Baltimore, Maryland. The Seamaster, according to Vice Admiral Thomas S. Combs, Deputy Chief of Naval Operations (Air), “seem[ed] ideally suited for eventual nuclear propulsion, due to its size and configuration, combined with [the] practically unlimited takeoff and landing areas water provides.”²⁹ Seamaster would have four modified turbo-jet engines, served by a single reactor. Its advantages as a platform would be low-altitude maneuverability, a large crew, high crew and

aircraft utilization, and substantial payload.³⁰ Seamaster would be used initially as a low-power, modest-performance seaplane for anti-submarine warfare and radar early warning, but experience with aircraft nuclear propulsion, the Navy predicted, would eventually lead to a high-speed attack plane.³¹

The Air Force's airframe development centered on the Convair Division of General Dynamics Corporation in Fort Worth, Texas. Convair was developing an aircraft with a canard configuration (that is, with horizontal stabilizers and control surfaces forward of the wing) that allowed the crew to be over a hundred feet from the reactor. The plane was to be subsonic, weigh 450,000 pounds, and be close to the same size as a B-52. Of its four turbojet engines, two would be powered by a reactor, either the General Electric direct-cycle type or the Pratt & Whitney indirect-cycle reactor;³² takeoffs and landings would be powered by the other two (conventional) engines, mounted under the wings. The aircraft had no tail but instead a vertical stabilizer-rudder assembly at each wingtip and the canard stabilizer-elevator surfaces forward on the fuselage.³³

Squabbling on ANP within the Department of Defense meant headaches for the AEC and national laboratories like Oak Ridge. Almost every time the DoD went through a policy spasm, alterations would be called for. Due to the interrelated nature of ANP components, nearly every change to technological requirements impacted upon reactor development, whether it pertained specifically to the reactor or not. Competing Navy and the Air Force ANPs now began to contribute to the rising research-and-development price tag.

In September 1953, Edward Teller expressed doubt that the airplane ever could reach the test-flight stage.³⁴ He was merely the most prominent among several AEC consultants with such views. In fact, reviews consistently produced ambivalent or negative results, and over time they leaned more toward the latter. While cost ultimately became the primary concern, the feasibility of ever producing a nuclear-powered airplane also repeatedly came up as an issue. Experts often expressed the opinion that funding and human talent would be better utilized elsewhere.³⁵ If ANP was inherently wasteful, interservice competition soon made its progress even more so.

Notwithstanding, things looked up considerably for the program when in August 1953 the Soviet Union successfully detonated its first thermonuclear device. This development gave a boost to those

170 Naval War College Review

in favor of developing the next generation of weapons. Their arguments were valuable to the ANP project in particular, because it remained far from deployment and was thus in a highly vulnerable and expensive state. Unfortunately for its advocates, a discussion at a meeting of the National Security Council in October 1953 explicitly linked budget issues with research projects under way and the personnel they required. The secretary of defense, Charles O. Wilson, expressed the opinion that the government "already had about all the good scientists who were available at work on these various AEC and Defense projects." He doubted "whether the expenditure of more money would produce a significantly larger number of good scientists." Secretary of the Treasury George M. Humphrey reinforced that point, asserting that "there was no way that you could spend money faster than on research, and unless this research was very carefully scrutinized, the results were often not worth the expenditure."³⁶

Thus, despite the apparently increased Soviet threat, indirect pressure on long-range, speculative projects like ANP continued to mount as the president and his inner circle became increasingly reluctant to burden a public exhausted from three years of the Korean War and impatient for sustained economic growth. Large-scale weapons programs with no immediate likely payoff, such as the ANP, stood out conspicuously in brainstorming sessions about what to scale down or even eliminate within the defense budget. It was at this point, in January 1954, that John Foster Dulles delivered a landmark address on massive retaliation—just in time, for the ANP project. In it the secretary of state threatened the Soviet Union with all-out nuclear punishment for any transgression.³⁷ The prospect of an aircraft that could strike the USSR from within the United States itself received renewed attention and even priority as tensions increased within the nuclear context.

Meanwhile, despite the back-and-forth between the Air Force and Navy, and among the political leadership, significant progress had been made in reactor development. The weight and size of the shielding had been reduced to levels much closer to operational limits. Advances also had been made in heat-resistant materials.³⁸

In April 1954, the Air Force decided that the time was right: it announced that an ANP bomber would be needed as soon as possible. The assertion did not preempt matters in the Air Force's favor,

however. In February 1955, the Navy produced Operational Requirement CA-01503 for its own ANP program; Developmental Characteristic CA-01503-3 followed in April. These documents defined the mission of the ANP primarily as long-range attacks against naval shore targets, warships, and shipping; secondary missions included mining and forward-area reconnaissance. The Navy hoped to have a prototype by 1961. In May, Secretary of the Navy Charles S. Thomas, agreeing that a nuclear propulsion system for a subsonic aircraft was desirable, proceeded to engage contractors to begin research.³⁹

Things were going well, then, for ANP in general in the first half of 1955. In April, for example, the concept reaped a dividend from the announcement of a decision by Eisenhower to "build and send around the world a new atom-powered merchant ship." The *New York Times* was confident that

the atom-powered merchant ship will have a significance beyond any of these [experimental power plants]. In the first place, visiting the ports of the world will bring both knowledge and a practical demonstration of the peaceful uses of atomic energy in medicine, agriculture and power production to the underdeveloped and power-starved areas of the world and help them thereby to plan their own industrial and technical revolution in the light of the atomic age.⁴⁰

Such exposure helped the pro-ANP lobby with a growing public-relations problem related to safe operation. Instead of being told to worry about the risk of a crash and associated environmental contamination, the informed public was now reading about possible commercial benefits as a side-effect of defense technology. Other uses for nuclear power also were proposed in this period, including an atomic-powered aircraft carrier, atomic locomotives, and atomic artillery.⁴¹

The fortunes of the ANP reached their crest in June 1955. At that time the AEC and DoD agreed that ANP should be accelerated, with the objective of flight testing by 1959. Authorized expenditures increased dramatically. Existing facilities were expanded, and construction began on new sites for additional research and development.⁴²

Interservice maneuvering, predictably, now went into high gear. Despite civilian expert opinion that the entire idea needed serious

172 Naval War College Review

reconsideration, the Navy increased pressure for an atomic-powered aircraft of its own; the program was riding high for the Air Force—why not get in on the action? The Navy argued that atomic power made more sense in a seaplane than in a bomber, since accidents would expose fewer civilians. Water, after all, is a better shield against radiation than the ground; in addition, the weight of the reactor would cause the wreckage to sink quickly. The Navy also pointed out that current engine designs being produced for the bomber project did not meet specifications for a subsonic seaplane. The Air Force, wishing to establish itself as the lead agency for ANP within the Pentagon, replied that any sea-based aircraft could be folded into its strategic bombing mission.⁴³ The Navy's rebuttal came in the form of a statement from the Secretary Thomas that seaplanes with nuclear propulsion "promised to be a potent supplement to the new Navy" and that nuclear seaplanes should belong only to that service.⁴⁴

Science advisors to the AEC by this time were ridiculing the seaplane idea, on which the Navy was spending several million dollars for preliminary designs.⁴⁵ In December 1955 the AEC postponed certain related Navy contracts to study the possibility of its own ANP system. A technical review group would determine whether additional research and development was necessary or existing programs could be adapted for Navy use; that group concluded that no specific Navy program was necessary, and the Department of Defense concurred.

Notwithstanding, the Navy's interest in having its own nuclear-powered aircraft grew even more in early 1956. (Ironically, in March 1956, a month after these decisions, General Electric had successfully tested a turbojet engine operating on nuclear power from a direct-cycle reactor.)⁴⁶ In March the Assistant Secretary of Defense (R&D), Dr. Clifford C. Furnas, told the Navy that although he agreed with the technical review group's findings, a Navy seaplane would receive support from existing and future program. The Chief of Naval Operations, Admiral Arleigh A. Burke, confirmed that the Navy would continue to work on independent aircraft design studies. As a result, in July the Defense Department impounded \$7.4 million of Navy funds earmarked for the ANP until such time as the service was able to orient properly its programs.

A memorandum from Colonel A. J. Goodpaster, Eisenhower's staff secretary, to Percival Brundage, director of the Bureau of the Budget, summed up the core of concern—finances. Goodpaster asked “whether it [was] correct to conclude that the proposal involves no new net increase or acceleration in expenditures or appropriations.”⁴⁷

The Decline and Fall of ANP

The President [Eisenhower] commented that the next thing he knows someone would be proposing to take the liner Queen Elizabeth and put wings a mile wide on it and install enough power plant to make it fly. Dr. [Herbert] York begged him not to let the idea get around, or someone would want to try.

—Minutes of a meeting, 23 June 1959⁴⁸

To the consternation of both the Air Force and the Navy, in August 1956 Eisenhower reduced the ANP budget. Although no hard evidence exists, it would seem the president gave every sign of agreeing with the general prognosis of the science advisors and looked forward to eliminating ultimately the expensive and doubtfully effective program. It seemed to him that the services had been fighting over a slice of the nuclear pie that many doubted ever would be “baked.” The mission of the overall ANP was now restricted to pure research for nuclear propulsion systems and shielding. This decision was tantamount to cancellation, since ANP was described as “more than 90% an engineering job and less than 10% research.”⁴⁹

President Eisenhower was determined, as he told Secretary of Defense Wilson and seven high-ranking military officers in December 1956, that the defense budget “must not keep going up and up each year to the point where we defeat ourselves.” He shared Secretary of the Treasury Humphrey's concern “as to whether we are being reckless with our economy.”⁵⁰ In view of that concern, Secretary Wilson told the president later in the meeting that he would be “backing down to some extent on the rate of research and development on the atomic powered aircraft.” Eisenhower agreed, at least implicitly, responding that he would like to see the AEC “put added resources to bear on controlled hydrogen reactions.” The president saw this as

174 Naval War College Review

the most likely path toward a major breakthrough, and he did not rush to the defense of the ANP.⁵¹

Advocates of the ANP project, however, had not given up. A very upbeat article in *Flying* magazine pointed to a bright future for the “A-plane” project. It asserted that the first flight could be expected by 1960—an earlier date than was hoped for by even the most optimistic supporters on the inside—and lauded progress in reactor development. The article noted the existence of interservice rivalry but described the Air Force as being in the dominant position with respect to ANP.⁵²

On the technical level, how to make the reactor light and small enough for an airplane yet sufficiently shielded to protect the crew continued to worry those still interested in the program. For example, in January 1957 even AEC advisor Alvin M. Weinberg, a staunch proponent, remarked that “the main problem of nuclear flight is the problem of obtaining adequate thrust with sufficiently low weight.”⁵³ The weight of scientific opinion continued to be against the program. Nonetheless, the Defense Department, though it had by now formally released Navy ANP funds, in fact authorized no spending in that account throughout most of 1957.

Then, on 4 October 1957, the Soviet Union launched Sputnik. This event raised the specter of an intercontinental missile launched from Russian soil striking the United States. That missiles might strike the nation from halfway around the world seemed even more revolutionary than the nuclear weapons they would carry, and as appalling.⁵⁴ The event sparked a crisis, fueled by media and congressional reactions, far broader than the national-security community alone. How on earth, or otherwise, would the United States respond?

The president received plenty of advice, some solicited and some not. A press conference held a few days later was characterized by pointed questions about the Soviet satellite and by what now would be called “spin control” on Eisenhower’s part.⁵⁵ The journalists’ questions focused on whether the United States had fallen behind the USSR in science and technology, most notably in areas with real or potential application to weapons. The president responded by blaming Congress for cutting his recommended appropriations for national security purposes. He also asserted, however, that the 180-pound weight of the Soviet satellite—heavier than any model

the United States hoped soon to deploy—was not a cause for concern: “Well, certainly again I am quoting the scientists, there is no indication that this will be scientifically more valuable.”⁵⁶

On 10 October the president met with the National Security Council and confronted the political problem posed by the Soviet satellite. Secretary of State Christian Herter summed up foreign policy reactions as “pretty somber.” At one point the group even spoke openly of the prospect of losing support in the United Nations as a result of the Soviet breakthrough. However, good reasons against that conclusion quickly emerged. Sensing that both the government and general public were overreacting, General Nathan F. Twining, the Chief of Staff of the Air Force, “cautioned that we should not permit ourselves to become hysterical about the Soviet achievement.”⁵⁷

Reports were emerging that the Soviets had successfully tested a nuclear-powered aircraft. Although they had no scientific credibility, these rumors compounded the administration’s problems and gave aid and comfort to advocates of the ANP.⁵⁸ One report, later debunked, arose from a sensational story spread by Representative Melvin Price (Democrat of Illinois), an avid supporter of ANP, following a visit to the Soviet Union.⁵⁹ The rumor, false as it was, reflected a fervent hope that had existed since the end of World War II among the public and even high-level decision makers for panaceas from science and technology. The result was renewed pressure on science to answer national-security threats. In that view, ANP must “fly first,” before the Soviet Union embarrassed the United States again.

The Navy did not hesitate to join the post-Sputnik enthusiasm to beat the Soviets in the science and technology race and to extend the interservice argument to an influential target within the executive branch. On 21 November 1957, Captain E. P. Aurand, naval aide to the president, sent a memo to James R. Killian, Jr., the chair and special assistant for science and technology of the newly created President’s Scientific Advisory Committee (PSAC). Captain Aurand pushed three points. First, “fly first” could not be achieved in a “militarily useful vehicle.” However, second, it could be accomplished for the equally important purposes of scientific advancement and global propaganda. Third, a Navy seaplane was best suited for this effort, since existing airframes could be used and they could travel anywhere there was water to land on, precluding dependence on foreign

176 Naval War College Review

landing fields.⁶⁰ Killian responded that the matter had not yet been addressed in any detail.⁶¹ In December 1957, the Chief of Naval Operations, Admiral Burke, presented a proposal to use for this purpose the British-made Princess flying boat, then in mothballs at Cowes. This huge aircraft, with its ten PW T-57 engines, would use a turbo-prop propulsion system with a reduced-size GE direct-cycle reactor. Admiral Burke described the Navy's intention as meeting the national objectives of early flight of a nuclear-powered aircraft.

The Air Force response was quick and heated. Secretary of the Air Force James H. Douglas pressed upon the secretary of defense four reasons why the Navy's nuclear seaplane should not supercede the Air Force's bomber program. First, the turboprop system for Princess had not left the drawing board, while the Air Force's turbojet was in a "hardware state of development." Second, the problems confronting the two systems were the same; the Navy could proceed no more quickly. Third, the Navy, unlike the Air Force, had no test facility. Finally, both systems used General Electric's direct cycle, and additions to the company's workload would result in overall delay, not earlier flight. Congressman Price supported the Air Force, convinced that competition would divert energies and slow results.⁶²

The Air Force and Navy staffs were also pushing Deputy Secretary of Defense Donald A. Quarles and the service chiefs, who also were indecisive, for a firm decision in their respective favor. Meanwhile, the ANP's opponents were receiving support from the President's Scientific Advisory Committee. James Killian selected from PSAC a panel of scientists and engineers, headed by Robert F. Bacher, to submit a recommendation on the ANP project. Its report, issued in February 1958, held little good news for advocates of aircraft nuclear propulsion. The report began with review of previous studies, in order to preclude criticism that yet another committee with no experience in the subject area had produced an unfair judgment.⁶³ It did not directly confront the basic issue of whether a nuclear-powered aircraft could be built but moved quickly to the enormous projected expense of bringing the idea to reality: "Total costs of the project from the present up to the achievement of first nuclear powered flight are estimated by the Air Force to be \$1,357 million. This program would require somewhat greater annual expenditures than the present limit of \$150 million." The report also emphasized the hazards of nuclear-powered flight in general. It specifically criticized the Navy's

new approach, on technical grounds: "The control problems of the reactor coupled to the variable propeller load through the engines are serious and unsolved. . . . We recommend that neither Air Force nor Navy accelerated programs for early manned nuclear flight be implemented at this time."⁶⁴ The panel concluded that "a rushed nuclear flight program poses serious technical risks and radiological hazards."⁶⁵

Eisenhower met in late February 1958 with Killian, Bacher, Quarles, and several other high-level officials, including military officers, to discuss the building confrontation over the ANP project. AEC chairman Lewis L. Strauss emphasized the psychological factors in favor of early flight. (Rumors continued to circulate about a Soviet ANP, and clarion calls from congressional proponents of aircraft nuclear power had spilled over into the media. The furor reached a peak with the publication of a so-called Air Force leak that the Soviets had already test-flown a nuclear-powered long-range bomber.)⁶⁶ He then, in a remarkable sleight of hand, asserted that the ANP work in progress would produce a reactor that could also propel a long-range missile.⁶⁷ His tactic represented a concession to the fact that missile development had been moving forward rapidly and that the balance had been swinging against the costly, even ponderous ANP. An association with missile development might co-opt some of the opposition, especially among scientists.

Meanwhile, the Navy had been pushing ahead with the nuclear Princess. During 1958 the Navy let contracts with General Electric, Pratt & Whitney, Convair, and Martin, among others, related to the project. By October, the Navy had forwarded to the Defense Department a paper arguing that its ANP project was feasible and that early flight was critical to long-term success. The Navy asked for immediate approval of a five-year ANP project with an estimated budget of two hundred million dollars, to include seventy-five million from the AEC. There was no formal reply from DoD; instead, the answer came in the 1960 fiscal budget: there would be no Princess. The only hope for a Navy ANP would be in conjunction with existing programs.

In view of the public outcry for a nuclear-powered jet as soon as possible, arising from anxiety over the apparent Soviet high-technology threat, it is not surprising that the president did not directly cancel the ANP. Nonetheless, convinced that the "fly first" goal was impractical, Eisenhower had cut funding and shifted remaining

178 Naval War College Review

resources to basic power-plant research. The AEC had argued that conventional aircraft already at the development stage could perform as well or even better in certain areas.⁶⁸ Still, the Navy continued to push for this costly and controversial program. Why?

One reason was that nuclear-powered flight still promised advantages that conventional propulsion could not match. Consider, for example, fuel requirements. A single pound of the uranium isotope U^{235} could produce the same amount of heat as 1,700,000 pounds of gasoline.⁶⁹ The needs for airborne refueling and for determining points of no return are eliminated. The gross-weight variance during a mission for an ANP aircraft would be 20 percent, while that of conventional aircraft runs between 50 and 70 percent, affecting optimum cruise altitudes and speeds.⁷⁰ It also appeared that improvements in reactor and shielding technology would translate into increased payload almost entirely, a ratio that could not be equaled by technological breakthroughs in conventional flight.⁷¹

Notwithstanding, presidential advisors asserted that the project should remain "essentially unchanged for the time being"—restricted to research on the power plant. The Navy's proposal for a sea-based aircraft languished, with feasibility as the main reason for lack of support in the White House: "With respect to this proposal, we do not believe that the technical status of the reactor development and the evaluation of the prospective applications have reached the point where the adoption of a specific program in that direction can be justified."⁷²

Yet another attempt by the Navy to salvage an ANP program for itself began in January 1959, when Secretary of the Navy Thomas S. Gates informed the secretary of defense that the Navy was convinced of the benefits of the indirect-cycle reactor. In fact, the Navy was willing to pay for research at Pratt & Whitney's Connecticut Aircraft Nuclear Engine Lab (CANEL). One obstacle was the fact the Air Force already had contracted CANEL. In March the Navy requested a joint arrangement between the two services, if the Air Force approved. The partnership would never occur; the Air Force claimed that its facilities contract specifically restricted all work to original objectives. The Defense Department finally settled the matter: the Navy's indirect cycle envisioned a sodium-based heat-transfer system, whereas the Air Force (requiring higher performance) used lithium, and their divergent requirements prohibited joint research.

The Navy could still, however, use any advances made at CANEL, and the services were to prepare cooperative plans. Moving toward consideration of an intermediate-power indirect cycle with a lithium-cooled reactor, the Navy altered its Pratt & Whitney contract to concentrate on propulsion components outside the reactor and its shielding.⁷³

The last chapter for ANP would be written primarily by a civilian scientist raised to a new and powerful post in DoD—Herbert York of the University of California’s Radiation Laboratory at Livermore, now Director of Defense Research and Engineering (DDRE). The DDRE was a particularly powerful position, referred to in some circles as the “vice president for science;”⁷⁴ the new DDRE personally had an excellent reputation in the Defense Department and at the White House, and this magnified his influence. York made a convincing argument against any notion of nuclear powered flight, expressing the opinion that no such aircraft with any useful military application could be developed before 1970.

Killian reinforced York’s view. Killian’s private notes for a meeting in June 1959 with the president indicate a commitment to basic research and some applied research, a definite rejection of development as premature. This document reiterated a series of conclusions reached by York. Ironically, it cited the Vanguard program—which had finally launched a satellite the year before—as evidence against an accelerated program; the long, checkered history of Vanguard “emphasize[d] the wastefulness and embarrassment of marginal design.”⁷⁵ Instead of reacting hysterically to the Soviet satellite breakthrough, Killian simply noted the risk of future embarrassment, stressing the scientific as opposed to political dimensions of security policy.

The final attempt to resuscitate ANP was made in an open hearing of the Subcommittee for Research and Development of the JCAE on 23 July 1959. Representative Price in particular was desperate to see the project come to fruition. There were two witnesses for the Navy: Under Secretary Fred A. Bantz and Admiral John T. Hayward, Deputy Chief of Naval Operations for Development. Under Secretary Bantz could be described as pessimistically cautious. He reported to the committee that the Navy needed much more information before it would be able to move beyond the \$6.5 million research contract with Pratt & Whitney included in the fiscal 1960 budget. Admiral

180 Naval War College Review

Hayward took the opportunity to say something that others were to say as well: "As I have said before, this particular program is a pretty good monument of how not to run a technical program." He pointed out that repeated changes in requirements, coupled with the failure to secure a functioning power plant before the airframe was developed, had resulted in an enormous waste of time and resources. If properly managed, he felt, ANP could have experienced the same success as the nuclear-powered submarine USS *Nautilus*. Research and development costs for *Nautilus* had been between \$800 and \$850 million; spending for ANP through fiscal 1960 amounted to almost \$991 million, yet even a prototype was years away.⁷⁶

The arguments made in July 1959 had little effect on the future of aircraft nuclear propulsion. The program dwindled to almost pure research and then faded away, despite all efforts to keep it alive. With his administration winding down, Eisenhower was reluctant to kill ANP once and for all, but work on the program, by whatever service or agency, ended with the stroke of a pen in the spring of 1961, when the Kennedy administration came to power.⁷⁷ ANP became one of the first cancellations by the new secretary of defense, Robert McNamara. As one official put it many years later, it took "a new administration that wasn't being hounded to death" to finish off the program.⁷⁸ By the time McNamara terminated the program, the massive expenditures needed to solve the remaining technical problems with ANP could simply no longer be justified. The new secretary of defense feared a highly publicized accident if the plane ever flew (concerning which, the public-relations hazard worried him as much as any physical damage). A nuclear airplane might be possible, but the investment in time and money was still prohibitively high, and the environmental dangers remained controversial.⁷⁹

A former official of Idaho National Laboratory who was involved in the ANP reactor development and testing in the 1950s expresses today no surprise that ANP was finally canceled. He still considers the program extremely dangerous, because of the risk of radioactivity, and is dismayed that it lasted as long as it did. One of his peers also addresses the longevity issue: "You can't kill that stuff [programs] with a stick." Experienced "Washington Beltway" players know how to work the system and are not beyond manipulating a situation to personal advantage, especially when enormous contracts may be on the line. However, widespread discussion of what the

nuclear airplane could achieve, assuming that it ever reached the deployment stage, produced a consensus that time had passed it by.⁸⁰ Evidence presented to the 23 July 1959 congressional hearing clearly shows that after over a decade of research and development, aircraft nuclear propulsion still had formidable technological challenges to overcome (see Table 1).

A Long and Costly Odyssey

Even after the ANP was cancelled, the general idea did not go away. At a hearing of the Joint Committee on Atomic Energy in 1962, Vice Admiral W. F. Raborn, Jr., Deputy Chief of Naval Operations, with supporting testimony from Secretary of the Air Force Eugene M. Zuckert, fought to keep Project PLUTO alive. PLUTO, begun in 1956, was a nuclear ramjet-driven missile that would fly at low altitude at supersonic speeds. The PLUTO missile would be able to change direction, or “dogleg,” after launch and deliver weapons with state-of-the-art accuracy. Seven million dollars had been spent in 1961, with an additional twenty-four million requested for fiscal year 1963, since the reactor had already proved successful. Admiral Raborn stated that the Navy wished to pursue this technology for deployment on surface ships and submarines. The missile also was believed to have space-flight potential.⁸¹

Two other related projects were being conducted at the time of ANP's demise. Project ROVER applied nuclear-propulsion technology to rockets capable of space travel. A second was considered by the Navy as late as 1971. In May of that year, two scientists of the Naval Research Laboratory in Washington, D.C., submitted a study finding that certain lighter-than-air craft, specifically rigid airships, were perfectly suited to nuclear propulsion, since the weight problems were virtually eliminated. One proposed airship, the ZRCV, would enclose almost ten million cubic feet and carry nine air-launched bombers. This flying aircraft carrier would have no reactor-size problems, and shielding the crew would be simpler. As to radiation exposure following an accident, “airship crashes have generally been relatively leisurely affairs, so that there should be less danger to the public.”⁸²

Even today these ideas have not fallen by the wayside. For example, debate among those who envision a manned space flight to Mars

Table 1
ANP Areas under Development as of 1959

<p>Power Plant</p>	<p>High-temperature fuel materials Turbomachinery Integration problems-reactor/engines Refinement & proof of shielding Practical controls Determination of installation requirements (cooling, ducting, mounting points, loads, clearances) Establishment of power plant performance under flight altitudes, speeds, loads & attitudes (thrust available, control response, transition behavior, afterheat removal, engine-out behavior)</p>
<p>Maintenance and Handling Equipment & Procedures</p>	<p>Installation and removal equipment for power plant & A/C systems Effects of aircraft activation on procedures & equipment Quick-disconnect requirements Afterheat removal Emergency equipment & procedures Special facility requirements & design criteria Aircraft handling equipment</p>
<p>Shielding Design</p>	<p>Exposure to design radiation fluxes shaping for minimum weight Selection of n/y ratios & degree of division Evaluation of internal equipment shielding effects Evaluation of shield augmentation requirements as related to ground handling Design & test of duct & cable shield penetrations</p>
<p>Environmental Development Testing & Evaluation of Location Requirements of Aircraft Subsystems for Max. Reliability</p>	<p>A/C (air conditioning, MTC [airbase & short range navigation & communication equipment], secondary power, flight control systems) Weapon systems (B&N, long range communications, ECM & IR equipment, active defense equipment)</p>
<p>Demonstration of the Practicability of Nuclear Powered Aircraft through the Effective Integration of the Above Factors</p>	<p>Sustained flight on nuclear power only Demonstration of reasonable & effective handling procedures Acceptable flight techniques Verification of design solutions Verification of operational capability, reliability, and safety</p>

Source: Joint Committee on Atomic Energy, *Aircraft Nuclear Propulsion Program: Hearing before the Subcommittee on Research and Development of the Congress of the United States*, 86th Congress, First Session of the Aircraft Nuclear Propulsion Program, 23 July 1959, Y4.AT7/2: Ai7., pp. 30-1.

has arisen over whether to use a nuclear power plant. In fact, decades after its cancellation, the aircraft nuclear power project enjoys an ironic postscript. First, although shielding from radiation was one of the most difficult obstacles to overcome, the research begun by ANP eventually matured into the tiles whose performance has been so critical to the success of the NASA space shuttle. Many other success stories eventually arose from the years of ANP development, in particular in the areas of materials and shielding (see Table 2).

* * *

To say that there is no use for a nuclear-powered plane is to immediately discount the Air Force argument for a cruising missile platform—and to discount this is tantamount to admitting that the entire Polaris missile program has been a waste of time and money.

—Fred Hamlin⁸³

But none of these technological advances have ever truly opened the way to a nuclear-powered aircraft. Why did the Navy not see that ANP was doomed? What is to be learned from the long and costly odyssey of the ANP? It would be in the realm of “counterfactuals” to speculate whether ANP would have been successful had efforts been concentrated on a single reactor design to be engineered for an airframe with constant mission requirements. As it was, the rivalry of the Navy and the Air Force for unique ANP missions and, accordingly, aircraft resulted in an enormous waste of resources and time, and not enough to show for the investment; the patience of critical decision makers ran out.

The ANP was not the first costly research project fought over by military services but never fully developed, nor will it be the last. Indeed, had the Air Force or the Army been able to produce coherent arguments against nuclear submarines, perhaps the *Nautilus* experience would have been as unsatisfying. Since then, measures have been taken to reduce interservice rivalry, especially the 1986 Goldwater-Nichols Act, which eliminated specified (that is, service-specific) commands at the joint level. It would be worthwhile to examine long-range research and development projects over the past decade for indications as to whether another ANP-like scenario could occur.

Table 2
Contributions of the ANP Program to Reactor Technology

Indirect-Cycle Program	<p>Extensive liquid metal technology including development of an advanced high-temperature lithium-cooled reactor system, including:</p> <ul style="list-style-type: none"> • High-strength refractory metal-columbium-zirconium alloy to reach previously unattainable temperatures at light weight • Applications for space, mobile packaged power, central station and marine power plants • Reliable, high-power-density fuel element permitting smaller cores, higher specific power, higher fuel burn-up, and lighter-weight systems
Direct-Cycle Program	<p>Metallic dispersion fuel element Zirconium hydride solid moderator technology Separation, purification, and fabrication of yttrium used as an alloying material to provide high strength and oxidation resistance to stainless steel Rhenium-tungsten thermocouples operating up to 3000°F in a nuclear environment Information on radiation effects on organic materials Ceramic fuel-element technology, including ceramic-coated wires resistant to high temperature and nuclear radiation Information on electrostatic precipitator systems to filter effluent air Calculation methods programmed for computer use, such as heat-transfer calculations Instruments and devices for determining test results and reactor control, including miniaturized items Operation of a turbojet aircraft engine on heat supplied by a nuclear reactor (65 continuous hours of operation at temperatures approaching 2000°F using metallic fuel elements)</p>
Circulating Fuel Reactor Program^a	<p>Molten-salt reactor program for civilian power at Oak Ridge National Laboratory New nickel-molybdenum alloy (INOR-8), which increased the operating life of reactors using lithium-based fused salts High-temperature liquid-metal pumps, valves, seals, heat exchangers, and instrumentation technology used in reactor development Corrosion data on various alloys with lithium, sodium, sodium-potassium, lead, bismuth, and various types of fused salts New materials, reactor grade inconel and stainless steels, and new fabrication techniques for large beryllium components Bulk shield reactor (swimming pool reactor) designed and built to obtain shielding data 5 MW spherical-geometry tower shielding reactor designed and built for use in radiation shielding development</p>

Source: U.S. Comptroller General, *Report to the Congress of the United States: Review of Manned Aircraft Nuclear Propulsion Program, Atomic Energy Commission and Department of Defense* (Washington, D.C.: General Accounting Office, February 1963), pp. 182-5.

a. This program was an earlier effort that was not pursued after initial research. It did not play an inherent role in the Navy ANP.

When considering the current phenomenon of the so-called “revolution in military affairs,” it is wise to remember the programs that failed, not just those that have been actually deployed. Breakthroughs in communications and computer science, for example, appear to promise technological “fixes” like those that ANP once seemed to offer. Critical and independent reviews of such projects are vital; more importantly, negative assessments must be given appropriate credence by decision makers within and outside the services, and kept in proper balance with other concerns. This is perhaps the most difficult task of all.

Notes

1. For a review of Navy support for technological innovation, see Vincent Davis, *The Politics of Innovation: Patterns in Navy Cases*, Social Science Foundation and Graduate School of International Studies Monograph Series in World Affairs (Denver: Univ. of Denver, 1967), vol. 4, no. 3, pp. 1–53; Bradd C. Hayes and Douglas V. Smith, eds., *The Politics of Naval Innovation*, Strategic Research Department Research Report 4-94 (Newport, R.I.: Center for Naval Warfare Studies, 1994); and Harvey Sapolsky, *Science and the Navy: The History of the Office of Naval Research* (Princeton, N.J.: Princeton Univ. Press, 1990).

2. The Aircraft Nuclear Propulsion Project was initially known as NEPA, for Nuclear Energy for the Propulsion of Aircraft. The choice of acronym depends on what stage of the project is at issue; “ANP” was used from 1951.

3. Giulio Douhet (1869–1930), who commanded the Italian aviation service in 1918 and published *Il dominio dell'aria* in 1921, believed that aerial attacks on cities and factories would reduce the support a military required and destroy the morale of the population, which would demand an end to the war. Bernard Brodie, *Strategy in the Missile Age* (Princeton, N.J.: Princeton Univ. Press, 1965.), pp. 71–106.

4. Letter from Harry S. Truman to Henry Stimson, 8 August 1945, Truman Presidential Library [hereafter TPL], Records of the President’s Air Policy Commission [hereafter APC], box 28.

5. For further details about the historical context, consult Donald J. Keirn, “The USAF Nuclear Propulsion Programs,” in *Nuclear Flight: The United States Air Force Programs for Atomic Jets, Missiles and Rockets*, ed. Kenneth F. Gantz (New York: Duell, Sloan and Pearce, 1960); W. Henry Lambright, *Shooting Down the Nuclear Plane*, Inter-University Case Program 104 (Indianapolis: Bobbs-Merrill, 1967); and Richard T. Sylves, *The Nuclear Oracles: A Political History of the General Advisory Committee on the Atomic Energy Commission, 1947–1977* (Ames: Iowa State Univ. Press, 1987).

6. It is not uncommon for technological advances to increase in frequency and magnitude as each side in a conflict tries to improve its relative strength. To cite just one example, the breakthroughs in World War II associated with Allied victory include the atomic bomb, radar, and the proximity fuse. Hitler’s decision not to push research and development until 1942 is seen as one explanation for Germany’s ultimate defeat; see Bernard and Fawn M. Brodie, *From Crossbow to H-Bomb* (Bloomington: Indiana Univ. Press, 1973), pp. 200–9. The role of science advisors also is significant. Once again, examples from World War II make the point very well: F. A. Lindemann and Henry Tizard of the British Science Advisory

186 Naval War College Review

Committee to the Royal Air Force persuaded the air marshals to recognize the new radar technology, acquire sufficient confidence in this untested discovery, install radar sets on airplanes, and train flyers to use them. Lindemann and Tizard also had to convince the military leadership to respond to the intelligence the new systems produced. Gerard Peil, "The Presidency and Science Advising: A Modest Proposal," in *The Presidency and Science Advising*, vol. 2, ed. Kenneth Thompson (Lanham, N.Y.: Univ. Press of America, 1987), p. 61.

7. Herbert F. York, *Arms and the Physicist* (Woodbury, N.Y.: American Institute of Physics, 1995), pp. 145–7. York describes himself as having been one of the "technological optimists" until he served in the nation's capital, from which he came to believe that many security threats actually originated; see also Lambright, p. 4. For negative opinions about the concomitant progress of science and society, see Eugene B. Skolnikoff, *The Elusive Transformation: Science, Technology, and the Evolution of International Politics* (Princeton, N.J.: Princeton Univ. Press, 1991); and C. P. Snow, *The Two Cultures: And a Second Look* (New York: Mentor Books, 1963).

8. The B-52, the first long-range, intercontinental bomber, took to the air in April 1952. Kosta Tsipis, *Arsenal: Understanding Weapons in the Nuclear Age* (New York: Simon and Schuster, 1983), p. 151.

9. Harry S. Baer, "Nuclear Power of Flying," *Flying*, June 1957, p. 25.

10. Keirn would retire at the rank of major general.

11. Engineering Division, Air Service Technical Command, "Proposed Air Engineering Development Center," 10 December 1945, pp. iii, vi, vii, TPL, Records of the President's APC, box 28.

12. Statement by Rear Adm. P. F. Lee, Chief of Naval Research, to the President's APC, 21 March 1946, pp. 2, 3, TPL, box 38.

13. Letter contract W-33-038ac-14801 (16250) came into force in May 1948; it specified a feasibility investigation, and research toward adoption, of nuclear energy as a means of propulsion for tactical aircraft. U.S. Comptroller General, *Report to the Congress of the United States: Review of Manned Aircraft Nuclear Propulsion Program, Atomic Energy Commission and Department of Defense* (Washington, D.C.: General Accounting Office, February 1963), p. 15.

14. J. S. Butz, Jr., "Navy Aims at Low Power Atom Seaplane," *Aviation Week*, 15 April 1957, pp. 30–2. The information in this article was obtained from a presentation by Cdr. A. D. Struble, Jr., at a Society of Automotive Engineers National Aeronautical Meeting in New York.

15. U.S. Comptroller General, p. 17.

16. The direct-cycle reactor, since it heated air directly, did present fewer technological difficulties, but it had the fundamental weakness that air does not absorb heat as well as liquid metal. In an indirect cycle, the surface needed for heat transfer to liquid metal is many times smaller than that needed to heat air, resulting in a smaller and lighter reactor. Overall engine weight is greater, but a single reactor can power multiple engines. The result for the direct cycle was that a larger amount of air had to go through the reactor, which also had to be larger to create enough energy to produce sufficient engine thrust. The direct cycle also, by necessity, being less compact, would require considerably more shielding than would the more efficient indirect-cycle plant, adding even more weight. Advocates of the indirect cycle thus argued that long-term considerations favored the indirect cycle. A third type of reactor also was considered; see Table 2.

17. Butz; and William A. Tesch [Col., USAF], "Nuclear Aircraft Presentation to Washington Chapter of Institute of Aeronautical Sciences, April 14, 1959," in Joint Committee on Atomic Energy, *Aircraft Nuclear Propulsion Project: Hearing before the Subcommittee on Research and Development* [hereafter Subcommittee Hearing], 86th Cong., 1st sess., 23 July

1959, pp. 154–8. Maintenance was not considered to be much of a problem. The reactor would have a modular, plug-in design, and remote control equipment would remove and reinstall it. With the reactor removed, the aircraft could be serviced in a conventional hangar. The Navy also was planning to conduct maintenance at sea.

18. Lambright, pp. 2–3.

19. One year earlier, Conant had told Keirn that “NEPA should be exclusively an AEC project, and that the Air Force should not be involved in it.” Sylves, p. 136.

20. The National Advisory Committee on Aeronautics.

21. President’s APC, *Survival in the Air Age: A Report by the President’s Air Policy Commission* (Washington, D.C.: U.S. Govt. Print. Off., 1 January 1948), p. 80.

22. This prediction proved to be near the mark for the amount final spent, but without producing an operational aircraft. As will be seen, administrative practices were to be blamed, as well as insufficient technological progress.

23. Feasibility studies took so long because the Defense Department failed to respond in a timely manner to AEC requests that it identify military requirements; U.S. Comptroller General, p. 123. For costs, *ibid.*, p. 124.

24. Thomas S. Gates, Jr., Oral History Research Office, Columbia University, 1972, Eisenhower Presidential Library.

25. Lambright, p. 9.

26. Subcommittee Hearing, pp. 7–8.

27. Lambright, p. 9. By law, only the AEC could conduct reactor research. The Navy and Air Force, therefore, funded only the remaining systems, such as the airframe and the conventional portions of the engines. This was significant, since it meant that over half the cost of ANP (over half a billion dollars) was to be borne by the AEC.

28. The Strategic Air Command after World War II did not exhibit much interest in this kind of long-term research and development project, concentrating instead on procuring conventional, long-range bombers. *Ibid.*, p. 4.

29. Harry S. Baer, Jr., “Power for Aircraft: Though Many Problems Still Exist, the A-Powered Plane’s Future Looks Brighter,” *Flying*, June 1957, p. 65.

30. Lionel W. Credit, “Flight Reliability in Nuclear Aircraft” (prepared for presentation at the Society of Automotive Engineers National Aeronautic Meeting, New York, 5–8 April 1960). Mr. Credit was an employee of Martin, which had by now determined that turbo-prop engines would be the best choice.

31. Butz, p. 30.

32. *Ibid.*, pp. 30–2.

33. *Science News Letter*, 13 August 1960, p. 105.

34. Lambright, p. 8. Teller’s views carried a great deal of weight, as evidenced by his influence on the development and ultimate deployment of another initially unpopular project, the thermonuclear bomb. See McGeorge Bundy, *Danger and Survival: Choices about the Bomb in the First Fifty Years* (New York: Random House, 1988); and Richard Rhodes, *Dark Sun: The Making of the Hydrogen Bomb* (New York: Simon & Schuster, 1995).

35. Richard G. Hewlett and Francis Duncan, *Atomic Shield, 1947–1952* (University Park: Pennsylvania State Univ. Press, 1969), *passim*.

36. Memorandum, 13 October 1953, p. 47, Eisenhower Presidential Library (EPL), NSC Series, box 4.

37. Edward Rhodes, *Power and Madness: The Logic of Nuclear Coercion* (New York: Columbia Univ. Press, 1989), pp. 98–100.

38. Lambright, p. 9.

39. U.S. Comptroller General, p. 134.

188 Naval War College Review

40. "Atom-Driven Ship Tour for Peace Is Planned by U.S.," *New York Times*, 26 April 1955, p. 1. The initiative produced the *Savannah*, launched in 1959 as the world's first nuclear-powered cargo ship. It made several demonstration cruises in the 1960s, but high costs prevented profitable commercial operation and resulted in its early retirement. "Savannah," *Encyclopedia Britannica Online*, retrieved January 2000 from the World Wide Web: <http://www.eb.com>.

41. *Bulletin of the Atomic Scientists*, March 1954, p. 107; September 1954, p. 303; and January 1957, p. 37.

42. Lambright, p. 11.

43. Fearing the loss of the ANP to the Navy or to unmanned flight, the Air Force also now proposed augmenting the nuclear reactor-powered engines with chemical engines to boost the plane's speed to two thousand miles per hour.

44. Lambright, p. 13.

45. One of these advisors, Edwin M. McMillan, asserted, "It would be sensible to fly one nuclear airplane [that is, the Air Force variant] before getting deluged with others." General Advisory Committee [hereafter GAC] of the Atomic Energy Commission, minutes of Meeting 46, 21–23 September 1955, p. 28.

46. Tesch, p. 155. The engine (a modified J-47) ran for 150 hours and generated over five thousand megawatt-hours.

47. "Memorandum for Director of the Budget," n.d., EPL, Department of the Navy (1), Office Staff Secretary: Paul T. Carroll, Subject Series, Alpha Subseries, box 20.

48. "Memorandum of Conference with the President," June 23, 1959, Eisenhower Presidential Library, Department of Defense, vol. 3 (6), box 1, p. 3.

49. Butz, p. 31.

50. Memorandum of Conference with the President, 26 December 1956, p. 3, EPL, Papers of the President, Dwight D. Eisenhower Diary Series, box 20. Adm. Arthur W. Radford, who was chairman of the Joint Chiefs of Staff, and Admiral Burke were in attendance. The ANP was mentioned only briefly, and no significant changes or decisions were made.

51. *Ibid.*, p. 5.

52. Baer, pp. 24–5, 60, 64–6.

53. GAC minutes, meeting 52, 17–19 January 1957, p. 21.

54. Vincent Davis, *The Admirals' Lobby* (Chapel Hill: Univ. of North Carolina Press, 1967), pp. 58–60.

55. Official White House Transcript of President Eisenhower's Press and Radio Conference 123, 9 October 1957, p. 3, EPL, Dwight D. Eisenhower Press Conference Series, box 6. Eisenhower reminded the journalists of his remarks at a 1955 press conference on U.S. progress toward satellite deployment: "At this press conference it was specifically stated that the 'data which will be collected from this program will be made available to all scientists throughout the world.'" In other words, the president tried, arguably without success, to give the impression that the United States did not see Sputnik as a threat to security. The United States would launch its first successful satellite, Explorer I, on 31 January 1958 and a second, Vanguard I, on 1 March.

56. *Ibid.*, pp. 13–4.

57. Memorandum, 11 October 1957, EPL, Dwight D. Eisenhower Papers as President, NSC Series, box 9.

58. Soviet scientific documents of the era make it clear that nothing of the kind could have occurred for a very long time. They emphasize the same problems that plagued nuclear propulsion of aircraft in the United States: thrust relative to weight, diversion of expensive and scarce resources from other projects, problems with recovering nuclear fuel,

and most importantly, how to remove heat from the reactor. None of these problems was even close to solution. See G. N. Nesterenko, A. I. Sobolev, and Yu. N. Sushkov, *Application of Atomic Engines in Aviation* (Moscow: Military Press of the Ministry of Defense of the USSR, 1957), pp. 267, 303, 304; and Yu. N. Sushkov, *Atomic Energy in Aviation* (Moscow: All-Union Society for the Dissemination of Scientific and Political Knowledge, 1958). Much of the technology described in these reports had come from U.S. and British publications. These documents are also available as appendices to Subcommittee Hearing.

59. Harold P. Green and Alan Rosenthal, *Government of the Atom: The Integration of Powers* (New York: Atherton Press, 1963), p. 243.

60. Memorandum from Aurand to Killian, 21 November 1957, p. 1, EPL, Office of the Special Assistant for Science and Technology, James R. Killian, Jr., and George B. Kistiakowsky, Records 1957-61, box 4.

61. Memorandum from Killian to Aurand, 4 December 1957, White House Office of the Special Assistant for Science and Technology, Records 1957-61, box 4, A76-16.

62. U.S. Comptroller General, p. 148; and "Navy Atom Plane Plan Disputed by Rep. Price," *Aviation Week*, 13 January 1958, p. 33.

63. For similar reasons the panel also met with representatives of the Navy, Air Force, and AEC; in addition, it visited the Pratt & Whitney plant at Middletown, Connecticut, and the General Electric offices in Evendale, Ohio. Robert F. Bacher et al., Memorandum for J. R. Killian, Jr., 11 February 1958, pp. 1-2, EPL. Among the earlier studies cited were those of the Littlewood group (April 1957), the Canterbury board (May 1957) and the Mills board (June 1957).

64. *Ibid.*, pp. 3-4. An interview with an official from the Idaho National Laboratory who had been a top-level expert on the nuclear ramjet for missiles elicited the same reaction. The expert pointed to any number of technical problems, including the primitive state of development of its proposed floating dock.

65. *Ibid.*, pp. 5, 7-8.

66. Robert Holtz, "The Soviet Nuclear-Powered Bomber," *Aviation Week*, 1 December 1958.

67. Memorandum of Conference with the President, 25 February 1958, p. 2, EPL, White House Office, Office of the Staff Security: Records, 1952-61: Subject Series, Department of Defense Subseries, box 10.

68. Richard G. Hewlett and Jack M. Holl, *Atoms for Peace and War, 1953-1961* (Berkeley: Univ. of California Press, 1989), p. 517.

69. Tesch, p. 155.

70. On the other hand, the heavier ANP aircraft would need more substantial, and thus heavier, landing gear and braking systems.

71. G. W. Newton, "Nuclear Engine Operating Considerations" (paper presented to the Society of Automotive Engineers National Aeronautical Meeting, New York, 1961), p. 2.

72. Letter from John A. McCone and Donald A. Quarles to Dwight D. Eisenhower, 2 January 1959, pp. 2, 3, EPL, Dwight D. Eisenhower Papers as President of the United States, 1953-61, Administrative Series, Box 25.

73. U.S. Comptroller General, pp. 158-60.

74. The DDRE advised the secretary of defense "in the functional fields of scientific and technical matters; basic and applied research; research, development, test, and evaluation of weapons, weapons systems, and defense material; and design and engineering for suitability, producibility, reliability, maintainability, and materials conservation" and "supervise[d] all research and engineering activities in the Department of Defense." U.S. Comptroller General, pp. 162-3.

190 Naval War College Review

75. James R. Killian, Jr., "Notes for Meeting with the President," 23 June 1959, p. 1, EPL, White House Office, Office of the Special Assistant for Science and Technology (James R. Killian, Jr., and George B. Kistiakowsky): Records 1957-61, box 4.

76. Subcommittee Hearing, pp. 49-56. General Keirn, in the same hearing, disagreed with Admiral Hayward's assessment and argued for "fly first" as the most practical way to move development forward (p. 32).

77. The Eisenhower administration had allotted thirty-five million dollars for DoD ANP research. The new administration cut twenty-five million dollars and diverted the remainder to the AEC. Papers of President Kennedy, Kennedy Presidential Library (KPL), Presidential Office Files, Departments and Agencies, box 77, Defense, 1/61-3/61, p. 7.

78. Dudley C. Sharp, Eisenhower Administration, Oral Research History Office, Columbia University, 1973, p. 64.

79. For instance, McNamara pointed out that the indirect cycle—the smaller and more compact approach—required over fifteen miles of fine tubing and metals as hot as two thousand degrees. Such an aircraft would weigh at least a half-million pounds; it would be subsonic, and it could not climb above thirty-five thousand feet. The cost of reaching flight testing was estimated at three to four billion additional dollars. Papers of President Kennedy, KPL, National Security Files, Departments and Agencies, box 273, Department of Defense, General, McNamara Testimony before Senate Armed Services Committee 4/4/61, pp. 22-5. Not all estimates were as negative; papers from NASA files indicate that flight testing required only \$700 million. Papers of President Kennedy, KPL, Presidential Office Files, Departments and Agencies, box 82, NASA, 1/61-3/51, p. 1.

80. Interviews with officials whose identities, as was agreed with them, will be protected.

81. *Science News Letter*, 13 October 1962, p. 241.

82. E. W. Clements and G. J. O'Hara, "The Navy Rigid Airship," Applied Mechanics Branch, Ocean Technology Division, Naval Research Laboratory, Washington, D.C., July 1972, pp. 17-20; quote on p. 18.

83. Fred Hamlin, "Why an A-Plane Crash Program Won't Work," *Armed Forces Management*, January 1959, p. 185.

Ψ