

---

Retrospective Theses and Dissertations

---

1974

## Analysis of a Portable, One Hundred Ampere Pulse Test Current Microhmmeter

John Marshall Allred  
*University of Central Florida*

 Part of the [Engineering Commons](#)

Find similar works at: <https://stars.library.ucf.edu/rtd>

University of Central Florida Libraries <http://library.ucf.edu>

This Masters Thesis (Open Access) is brought to you for free and open access by STARS. It has been accepted for inclusion in Retrospective Theses and Dissertations by an authorized administrator of STARS. For more information, please contact [STARS@ucf.edu](mailto:STARS@ucf.edu).

---

### STARS Citation

Allred, John Marshall, "Analysis of a Portable, One Hundred Ampere Pulse Test Current Microhmmeter" (1974). *Retrospective Theses and Dissertations*. 83.

<https://stars.library.ucf.edu/rtd/83>

ANALYSIS OF A PORTABLE, ONE HUNDRED AMPERE PULSE  
TEST CURRENT MICROHMMETER

BY

JOHN MARSHALL ALLRED

B.S.E.E., North Carolina State University, 1962

RESEARCH REPORT

Submitted in partial fulfillment of the requirements for  
the degree of Master of Science in Engineering  
in the Graduate Studies Program of  
Florida Technological University, 1973.

Orlando, Florida

## ABSTRACT

This report is an analysis of the Model RT-2 Microhmmeter which is a portable apparatus using a pulse current power source in the measurement of load resistances in the microhm range.

The need for accurately measuring resistances in the microhm range is quite real for testing electrical power circuit breaker contact resistance. Both during acceptance checking within the manufacturing process and in the field for preventative maintenance, contact resistance must be accurately determined. Before the invention of the Model RT-2 Microhmmeter, no device existed which could accurately measure resistances in the microhm range that was readily transported by an unaided individual.

The design of the Model RT-2 Microhmmeter is based on a specification set derived from user requirements, and ANSI C37.09. In addition, a weight limit of 25 pounds for the portable apparatus was imposed by the designer which includes the weight of the self-contained power source.

This paper suggests changes that will result in both weight and power consumption savings. A major change in the high current power supply circuit is suggested that will allow the microhmmeter to be a more versatile piece of test equipment.

The Model RT-2 Microhmmeter is operational and has been successfully proven in the field. By using the portable microhmmeter, the reduction in the amount of time required to determine contact resistance can result in appreciable cost savings to the user.

## TABLE OF CONTENTS

	<u>Page</u>
ABSTRACT . . . . .	iii
CHAPTER I	
INTRODUCTION . . . . .	1
CHAPTER II	
INTRODUCTION . . . . .	7
CONTROL SECTION. . . . .	7
HIGH CURRENT POWER SUPPLY. . . . .	13
METER READOUT SECTION. . . . .	16
POWER SUPPLIES . . . . .	18
CHAPTER III	
RECOMMENDATIONS AND CONCLUSIONS. . . . .	21
BIBLIOGRAPHY. . . . .	24

# ANALYSIS OF A PORTABLE, ONE HUNDRED AMPERE PULSE TEST CURRENT MICROHMMETER

## CHAPTER I INTRODUCTION

A microhmmeter that has the ability to measure resistance in the microhm range with a resolution of 0.1 microhms has recently been developed and is now being marketed. This chapter will explain why this new microhmmeter was developed and will explain the intended use of the meter. In addition, the performance specifications will be identified and a block diagram of the microhmmeter will be developed.

Manufacturers and users of large electrical power circuit breakers need to accurately measure contact resistances which are in the microhm range. The manufacturer needs to ascertain that the contact resistance in a new breaker falls within some acceptable low range before the breaker is allowed to be shipped to the customer. Since contact resistance is of such importance, each circuit breaker contact is tested prior to its shipment. The users of these large circuit breakers need to accurately measure the contact resistances to be able to detect a contact that needs refurbishing prior to its complete failure.

At present, there are several test devices being used to test circuit breaker contact resistances. Each of these devices must produce a minimum DC test current of 100 amperes to comply with the industry standard for checking circuit breaker contact resistance.<sup>1</sup> This requirement has caused the test equipment used to be both heavy and bulky. As an example, at one large manufacturer of power circuit breakers, the 100 ampere test current required is

supplied by a permanently located motor-generator set. The power breakers are moved by large overhead hoists to the test meter.

Other devices have been developed that are considerably more portable than using a motor-generator set to supply the 100 amperes. The lightest weight test instrument for measuring low resistance of which the writer is aware is manufactured by Biddle Instruments.<sup>2</sup> This measurement system consists of a Ducter<sup>®</sup> low resistance ohmmeter and a portable battery supply. The low resistance ohmmeter uses a cross-coil galvanometric indicator and, as such, must be treated with a proper amount of care to avoid damage to the indicator. The only unit listed in the Biddle catalog that uses 100 amperes test current has a range of 100 microhms and the recommended portable battery power source generates 100 amperes at 1 volt. Therefore, the maximum resistance of the combination of the load and the current carrying test leads is 10 milliohms. For this reason, the current carrying test leads must be constructed of a very heavy wire. The total weight of the system, without the test leads, is 59 pounds.

If then a microhmmeter could be developed that would be more accurate, more rugged, could operate with much smaller test leads, would supply 100 amperes test current with up to 10 volt drive capability, and would weigh less than 50% of the present best available microhmmeter, a definite need would be filled.

With the knowledge of the limitations of the existing low resistance test meters, Alber Engineering, Inc., decided to design a truly portable microhmmeter. The predesign goals were to develop a microhmmeter that would weigh less

than 25 pounds and that would have overall dimensions no greater than 10 x 16 x 8 inches.

This total weight and size would include all the power sources necessary to supply the 100 ampere test current with a drive capability of 10 volts, plus all other power sources necessary for the various internal components. In addition, the new microhmmeter would have sufficient stored energy to allow for an eight hour operational life, based on realistic usage, before the batteries would require recharging. The microhmmeter would be designed with a digital readout which would eliminate the problems associated with an analog type readout.

The design approach taken by Alber Engineering, Inc., makes use of the well-known four wire measurement system. Since the test current is 100 amperes, the voltage drop measured directly across the load will appear on the digital readout directly in microhms with the appropriate decimal shifting. The major engineering task in the design of the Model RT-2 Microhmmeter was designing a regulated 100 ampere power supply that, when combined with the other components, would weigh no more than the 25 pound predesign goal. The 25 pound limitation for a power supply which is capable of continuously supplying 100 amperes at up to 10 volts, appears to be an impossibility. To overcome the weight problem, the Model RT-2 uses a regulated 100 ampere current pulse with a duration of 75 milliseconds. Near the end of the 100 ampere current pulse, and after checking that the amplitude of the current pulse is within acceptable limits, a high speed analog to digital converter samples the voltage drop across the unknown load resistance and displays the results on the digital readout.

The specifications for the Model RT-2 portable microhm-meter, as described in the manufacturer's product description sheet,<sup>3</sup> are listed below:

Full Scale Reading:	1,999 microhm, standard. Optional full scale ranges of 19.99 milliohm or 199.9 microhm are available.
Indicating Device:	3½ digit digital readout
Drive Voltage:	10 volts
Drive Current:	100 amperes
Power Requirements:	Powered by self-contained rechargeable batteries. (Battery charger supplied with instrument.)
Accuracy:	±0.5% of reading ±1 microhm
Resolution:	1 microhm (.1 microhm optional)
Maximum Load Resistance:	100 milliohms total loop resistance
Operating Time:	(7 - $\frac{\text{number of tests}}{30}$ ) hours
Recharge Time:	14 hours
Weight:	25 pounds (Does not include current carrying leads.)
Overall Dimensions:	10 x 16 x 8 inches
Test Leads:	Supplied to meet customer requirements. Leads can be made of wire as small as #8 AWG.

The circuits of the Model RT-2 portable microhmmeter are divided into four major sections. These are: (1) the high current supply, (2) the control section, (3) the meter readout section, and (4) the operating voltage power supply section. A block diagram of the circuit is shown



in Figure 1. In the following chapter, a description of the operation of the circuits in each of the major blocks of the block diagram is presented, and each circuit is analyzed for possible improvement.

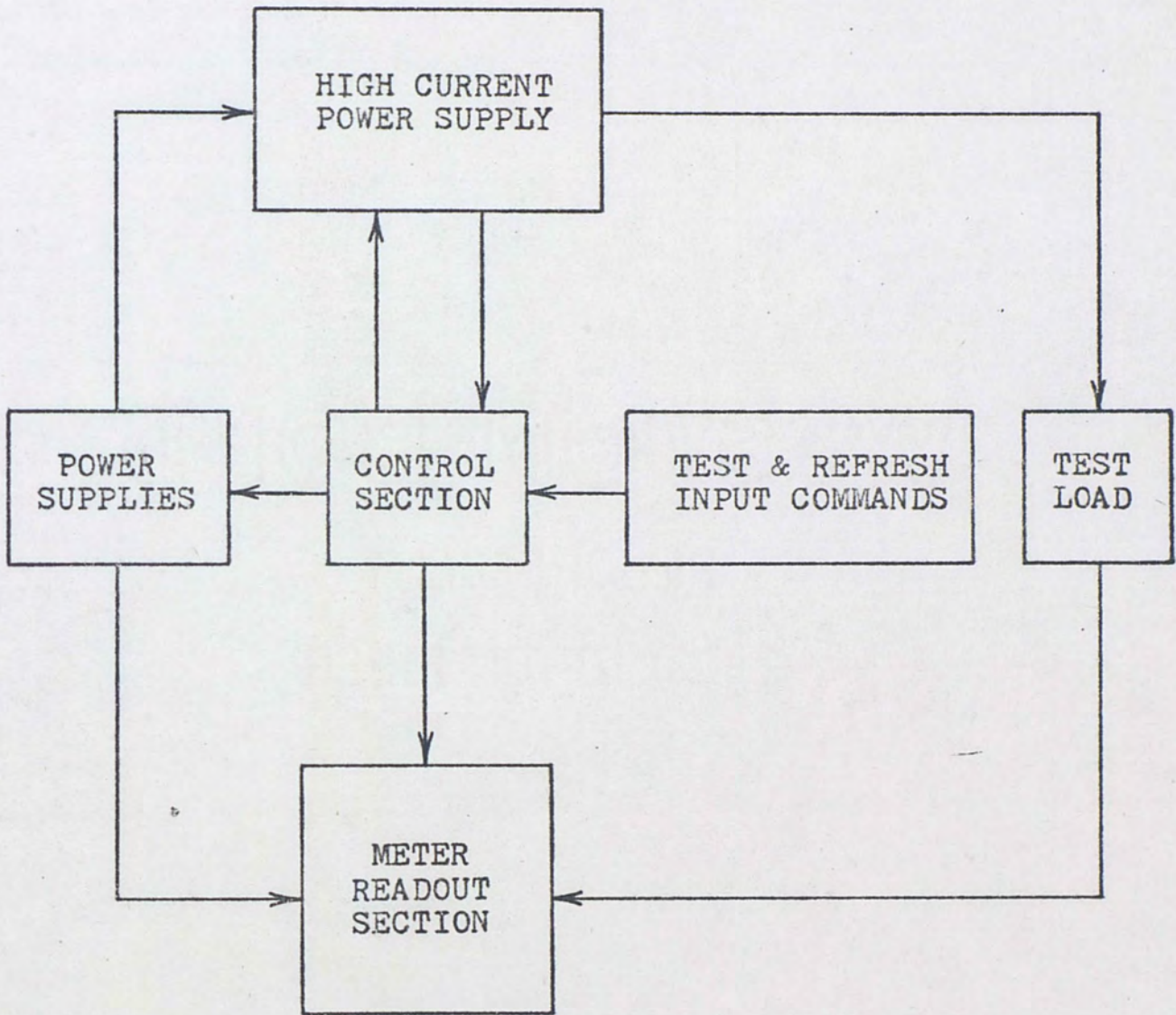

Figure 1. Block Diagram of Model RT-2 Portable Microhmmeter

## CHAPTER II

### INTRODUCTION

In this chapter, the operation of the circuits in each of the major blocks of the system block diagram will be discussed in detail. At the conclusion of the discussion on each circuit, an analysis of the circuit is made. The analysis of the circuits is based on the following considerations:

1. Energy conservation
2. Weight and size minimization
3. Cost effectiveness.

In several cases, the advantages of a change in the circuits for either energy conservation or weight or size reduction are cancelled by the increase in cost. In cases where the cost of a circuit or component is subject to change, it will be presented as a possible improvement to the design.

### CONTROL SECTION

#### DESCRIPTION:

The control section of the Model RT-2 Microhmmeter must generate the necessary signals to activate the various circuits in the proper sequence to achieve an accurate reading. The control section consists of integrated circuit timing devices,<sup>4</sup> integrated circuit logic gates,<sup>5</sup> switching transistors, pushbutton switches mounted on the control panel, and miscellaneous compensating components.

The circuit that must be sequenced in the microhmmeter are:

1. The high current power supply
2. The analog to digital converter
3. The error detection circuit
4. All logic power supplies.

The timing sequence for these items is indicated in Figure 2.

The timing sequence is initiated by depressing the test push-button switch on the control panel. When this occurs, the start flip-flop is driven to the set condition, which activates the power supplies for the voltage and current regulator integrated circuit and the voltage comparator integrated circuit and applies power to the display section of the digital readout. At the same time that the start flip-flop is set, two timers that are wired for monostable operation are set. One is set for 20 seconds and the other is set for 2.4 seconds. The 20 second timer is used to power down the microhmmeter circuit after a test has been made. The 2.4 second timer is used to provide a stabilizing time period for the various circuits after the power is applied. At the end of the 2.4 second period, three more monostable timing circuits are simultaneously set. These three timers are set for 65, 75, and 150 milliseconds respectively. The 75 millisecond timer, when it is set, activates the high current power supply which provides the 100 ampere current to the test load. This current is turned off at the end of the 75 millisecond timing period. The 65 millisecond timer activates the current error detection circuit and commands the analog to digital converter section of the digital panel meter to take a reading at the end of the 65 millisecond timing period. The 150 millisecond timer is used to deactivate the DC to DC converter, which is used in the capacitor

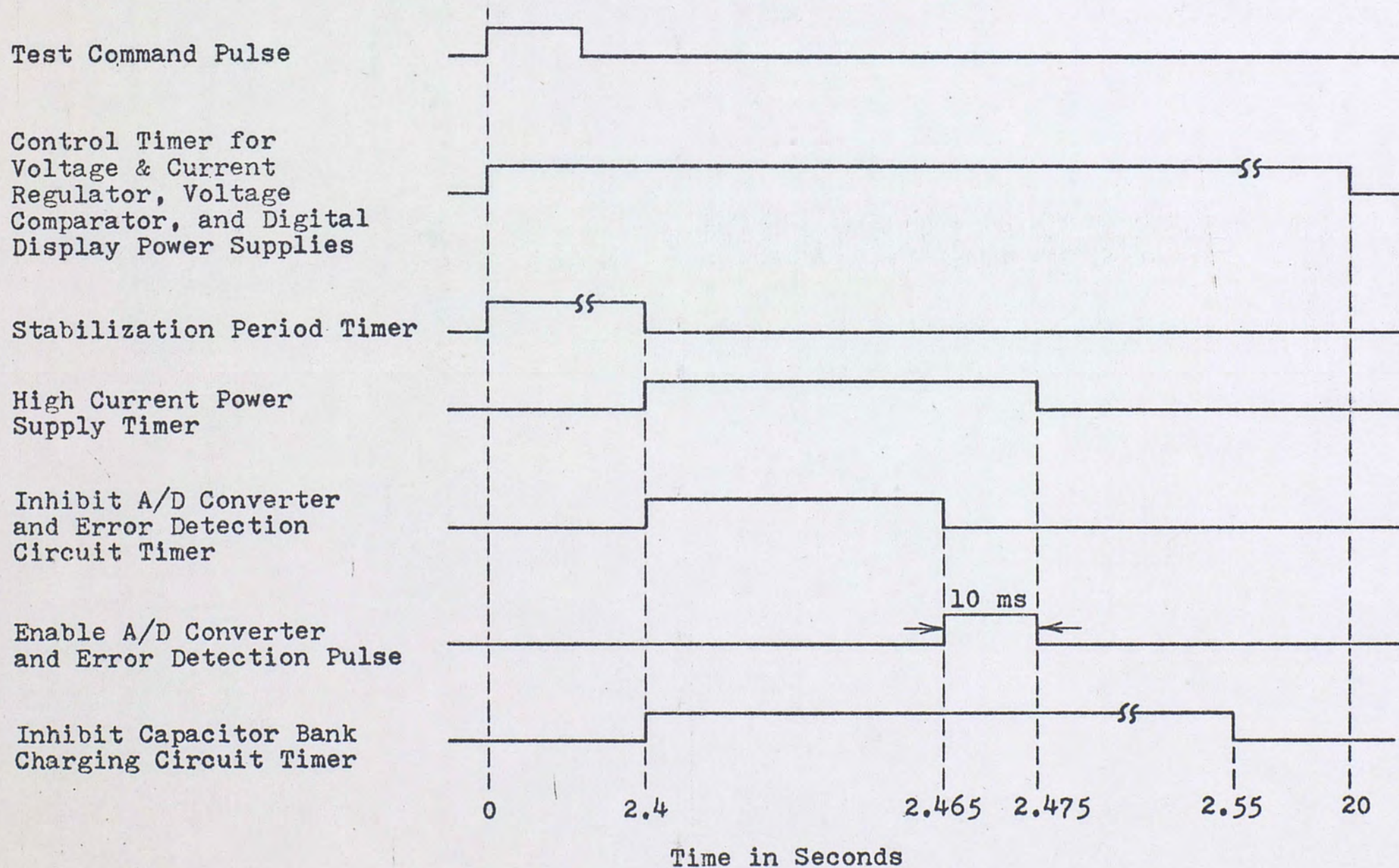

Figure 2. Control Section Timing Diagram

bank charging circuit, during a test. At the end of the 150 milliseconds time period, the DC to DC converter is allowed to recharge the capacitors.

### ANALYSIS:

An analysis of the control circuits indicates that the design of the control circuits is consistent with the pre-design goals. The selected components are all state-of-the-art in size and power consumption. However, the designer has chosen to couple two timers that operate in sequence by use of two nand gates, as shown in Figure 3. While the integrated circuit nand gates weigh little and their cost is almost insignificant, the timers could have been coupled by use of a capacitor, as shown in Figure 4. The output wave shape is shown for each circuit in Figure 5. Since it is the negative going pulse that triggers the timer and the shape of the pulse returning to +5 volts is of no consequence, the capacitivity coupled scheme will work as well as the two nand gates. The result is a small weight, size, and cost savings, as well as a small power conservation.

In addition to power savings realized by using capacitors to couple the sequence timers, the designer could have realized still greater power savings by not leaving all of the timers powered at all times. Referring back to the timing sequence in Figure 2, it is seen that two timers are initiated at time  $t = 0$ , so these timers must remain powered all the time to be ready to accept the initial test command. However, the remaining three timers could be powered up in the same manner as the digital display on the digital panel meter. This means that the three timers would be powered for 20 seconds at a time. A further justification for doing this is that the timing intervals of the

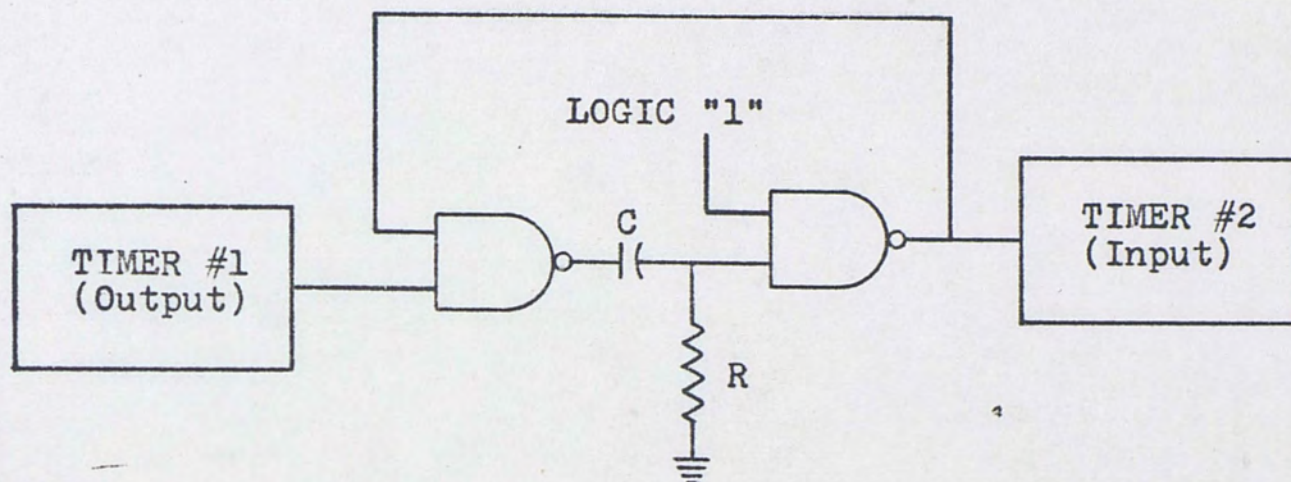

Figure 3. Nand Gate Coupled Sequential Timers

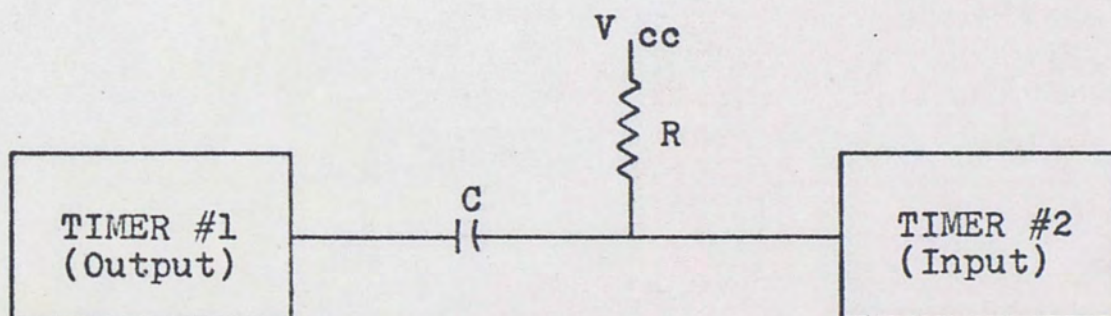
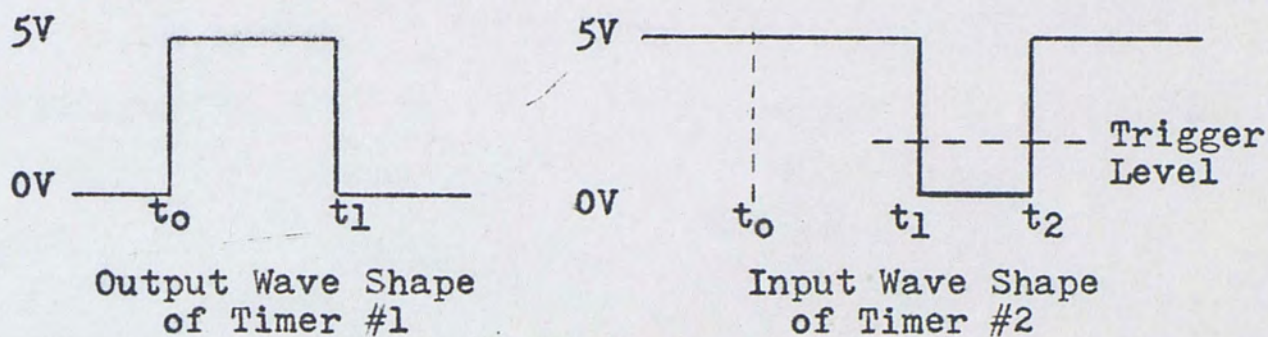
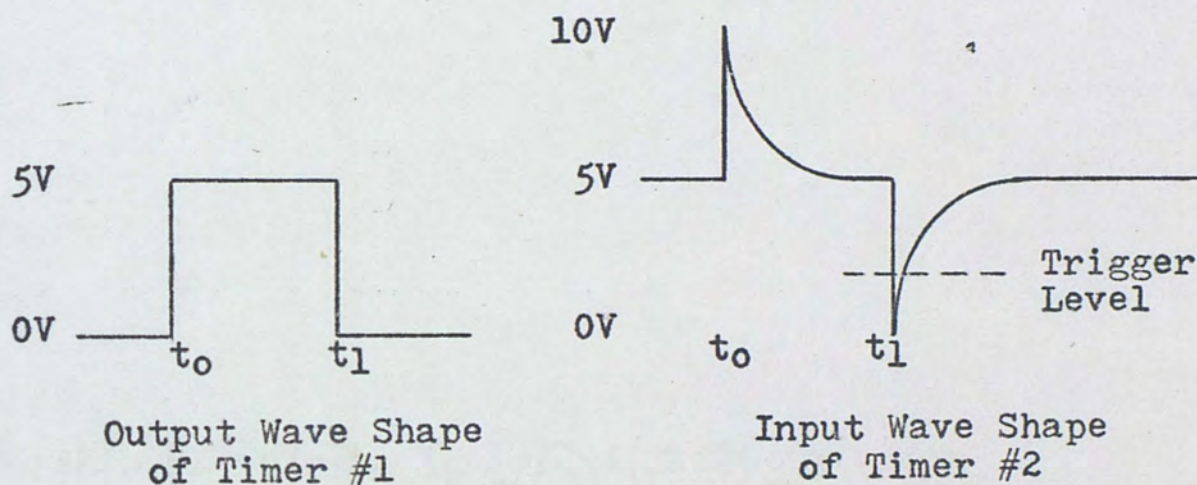

Figure 4. Capacitively Coupled Sequential Timers



Wave shapes for nand gate coupled timers in Figure 3, where  $t_2 - t_1$  will depend upon the selection of R&C.



Wave shape for capacitively coupled timers in Figure 4, where the selection of R&C will determine the time the input pulse will stay below the trigger level.

Figure 5. Output and Input Wave Shapes for Nand Gate Coupled and Capacitively Coupled Sequential Timers



timers used is independent of supply voltages. While the power saved by this scheme is admittedly minimal, the only change required would be a relocation of one existing wire from each timer. No additional components would be required.

## HIGH CURRENT POWER SUPPLY

### DESCRIPTION:

The high current power supply of the Model RT-2 Microhmmeter must be capable of providing a regulated current of 100 amperes at a voltage not greater than 10 volts for a period of 75 milliseconds. This is accomplished by first charging a storage capacitor and then discharging the capacitor through the test load. A current and voltage regulating section is included to assure that the current regulates to 100 amperes and that the voltage limits at 10 volts. A block diagram of the high current section is shown in Figure 6.

When the master on/off switch, located on the control panel, is placed in the on position, a DC to DC converter will start converting the 5 volt supply voltage to 30 volts to charge the storage capacitor. As the capacitor voltage approaches the 30 volt charging level, the current flow into the storage capacitor will diminish in magnitude and, at a preset minimum level, a low limit current detection circuit will switch on the ready light and activate the automatic refresh circuit. The automatic refresh circuit is used to keep the storage capacitor, which has internal leakage, fully charged by automatically turning on the DC to DC converter for four seconds in every sixty seconds. Since no current flows between the DC to DC converter for the majority of the time, the low current detection circuit is designed to consume power only when the current is above the low limit level.

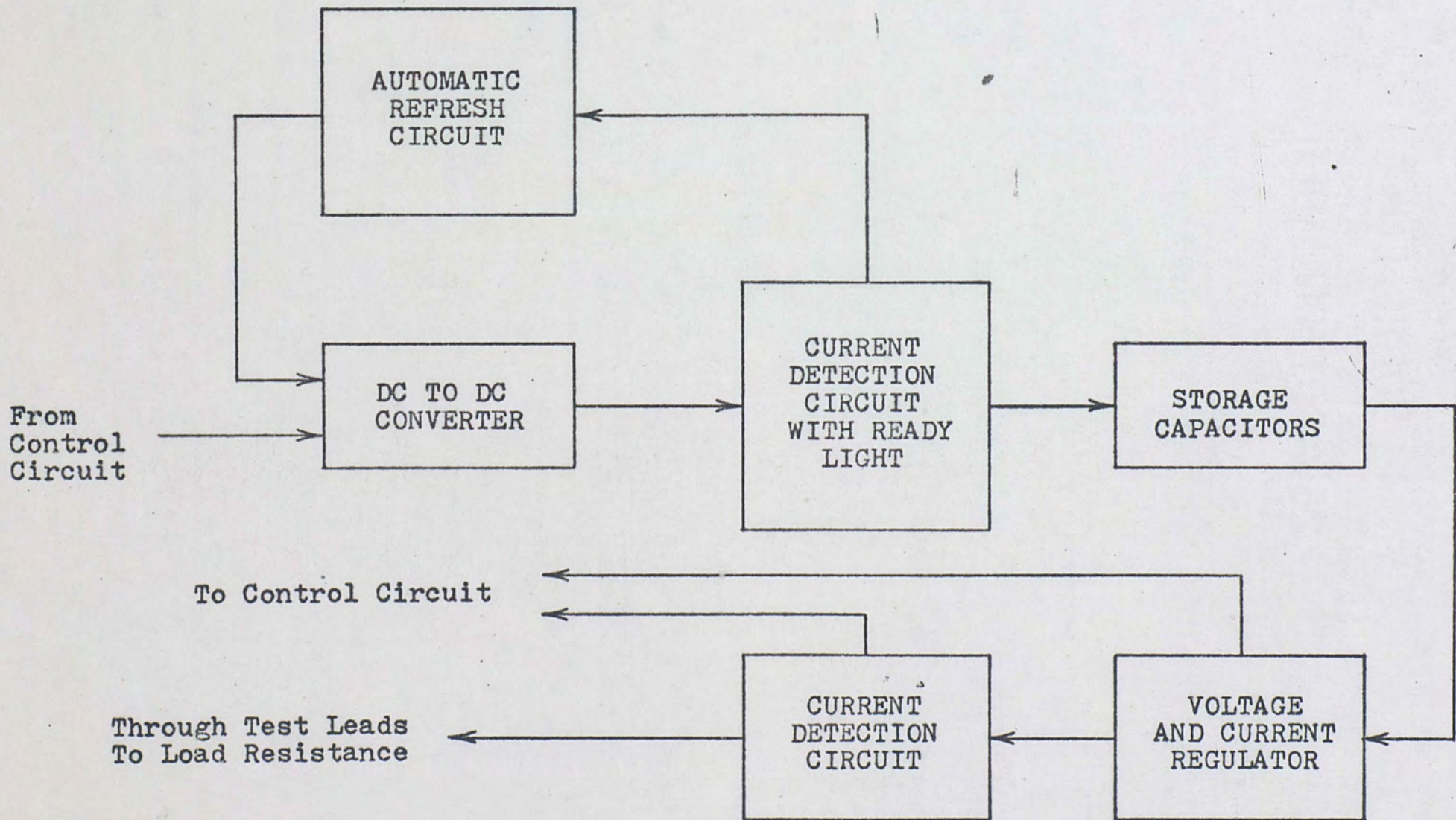

Figure 6. Block Diagram of High Current Power Supply

When the ready light is illuminated, the microhmmeter is ready to be used, and can be left in this condition for an extended period of time (limited only to battery life) with the storage capacitor remaining fully charged.

As discussed in the control section of this chapter, when the test pushbutton is depressed, the control system will send a control signal to the current and voltage regulation section of the high current supply. This control signal will release a "clamp" on the current and voltage regulator and the storage capacitor will begin to discharge through the power transistors and the test load. The integrated circuit voltage and current regulator used in this circuit requires a sense resistor sized to produce a 250 millivolt drop at the regulated current.<sup>6</sup> In this case,

$$R_s = \frac{250 \text{ mv}}{100 \text{ amp}} = 2.5 \text{ milliohms}$$

The voltage drop across the sense resistor is also used as inputs to two voltage comparators. The comparators are set to detect if the regulated current is within a band of 100 amperes  $\pm 0.5\%$ . The output of the voltage comparators are gated by the control section such that the error light is illuminated if the regulated current is outside the allowed band at the time the microhm reading is being read. If the error light is illuminated, it will remain on for the duration of the displayed microhm reading on the digital meter readout.

Seventy-five milliseconds after the 100 ampere current is turned off, the 150 millisecond timer will reactivate the DC to DC converter and the charging cycle will repeat.

## ANALYSIS:

The high current power supply section of the Model RT-2 Microhmmeter does successfully perform all functions required. The analysis of the high current power supply is limited by the lack of test data. However, certain conclusions can be reached based on known data. Due to current transformers found on all large circuit breakers, an inductance exists that will affect the rise time of the 100 ampere current pulse. With the secondary of the current transformer open circuited, the time constant of the current pulse will be at its smallest value.

Since the value of the inductance of the circuit breaker is unknown, there is no way of determining if the high current power supply is overdesigned. High current power supply circuit changes will be suggested in Chapter 3 that will make the microhmmeter a more versatile piece of test equipment.

## METER READOUT CIRCUIT

### DESCRIPTION:

The Model RT-2 Microhmmeter operates on the four wire measurement principle. Since the test current is a regulated 100 amperes, the calculation of load resistance merely becomes a decimal placement in the voltage readout. The meter readout section then must accurately measure the analog voltage across the test load, at the test load, and convert this analog signal to a digital number and display the digital number.

The meter readout section consists of a commercially available  $3\frac{1}{2}$  digital panel meter (DPM).<sup>7</sup> The selection of the digital panel meter was dependent upon several demanding

requirements of the microhmmeter circuit. Referring to the timing sequence, Figure 2, it is observed that the digital panel meter only has a 10 millisecond sampling period. This requires a DPM with a fast analog to digital conversion speed. In addition, if the microhmmeter is to have a resolution of 1 microhm, then the DPM must have a resolution of 0.1 millivolt. The DPM chosen has a sample rate of 200 samples per second and a 0.1 millivolt resolution available to meet the requirements above. The DPM also has external start conversion command, as it must for use with this circuit. The power required for the DPM is +5 volts which is available in the microhmmeter. The DPM requires 750 milliamperes at 5 volts, which represents a very appreciable load on the 5 volt power source. To lessen this power drain, the DPM has been modified to permit the light emitting diode display readout to be sequenced on for a period of 20 seconds. A refresh button is supplied on the control panel that enables the operator to recall the last reading, which is always stored in the memory section of the DPM for another 20 seconds. An error light is provided on the control panel which illuminates if the regulated current is not 100 amperes during the sampling period. This informs the operator that the reading on the DPM is in error and should be ignored. This error light is powered from the DPM display power so that if an erroneous reading is recalled by the operator, the error light is illuminated again.

#### ANALYSIS:

The digital panel meter selected by the designer is capable of meeting all performance specifications. Its weight and size is compatible with the present state-of-the-art meters. The only place where the selected DPM seems to be unsuitable for this application is in the supply voltage current requirement. The designer has made some progress in reducing this

current requirement by clocking the supply voltage to the light emitting diode display.

It would be advisable for the designer to approach the manufacturer of the DPM to see if it is feasible to eliminate all the extra features that are not required for this application. In addition, the power busses internal to the DPM should be separated so that it is possible to leave power to the memory section and switch all other power off when not needed. Even if these changes resulted in an additional cost of the meter, the savings in the weight and size of the supply voltage battery, and possibly the savings in the battery cost, might justify a higher DPM cost.

## POWER SUPPLIES

### DESCRIPTION:

The power supply section of the Model RT-2 Microhmmeter consists of a rechargeable battery, plus all the DC to DC converters required by the various components within the microhmmeter. A block diagram of the power supply section is given in Figure 7.

The battery supply consists of six nickel-cadmium cells connected in series, which yields 8.22 volts with all batteries fully charged. The voltage regulator regulates to 5 volts, which is the basic supply voltage used throughout the microhmmeter. The inputs to all the DC to DC converters are 5 volts and are switched on or off by the control circuit timers, as described in the control section of this chapter. In addition, the regulated 5 volt supply to the digital display is controlled by the control circuit.

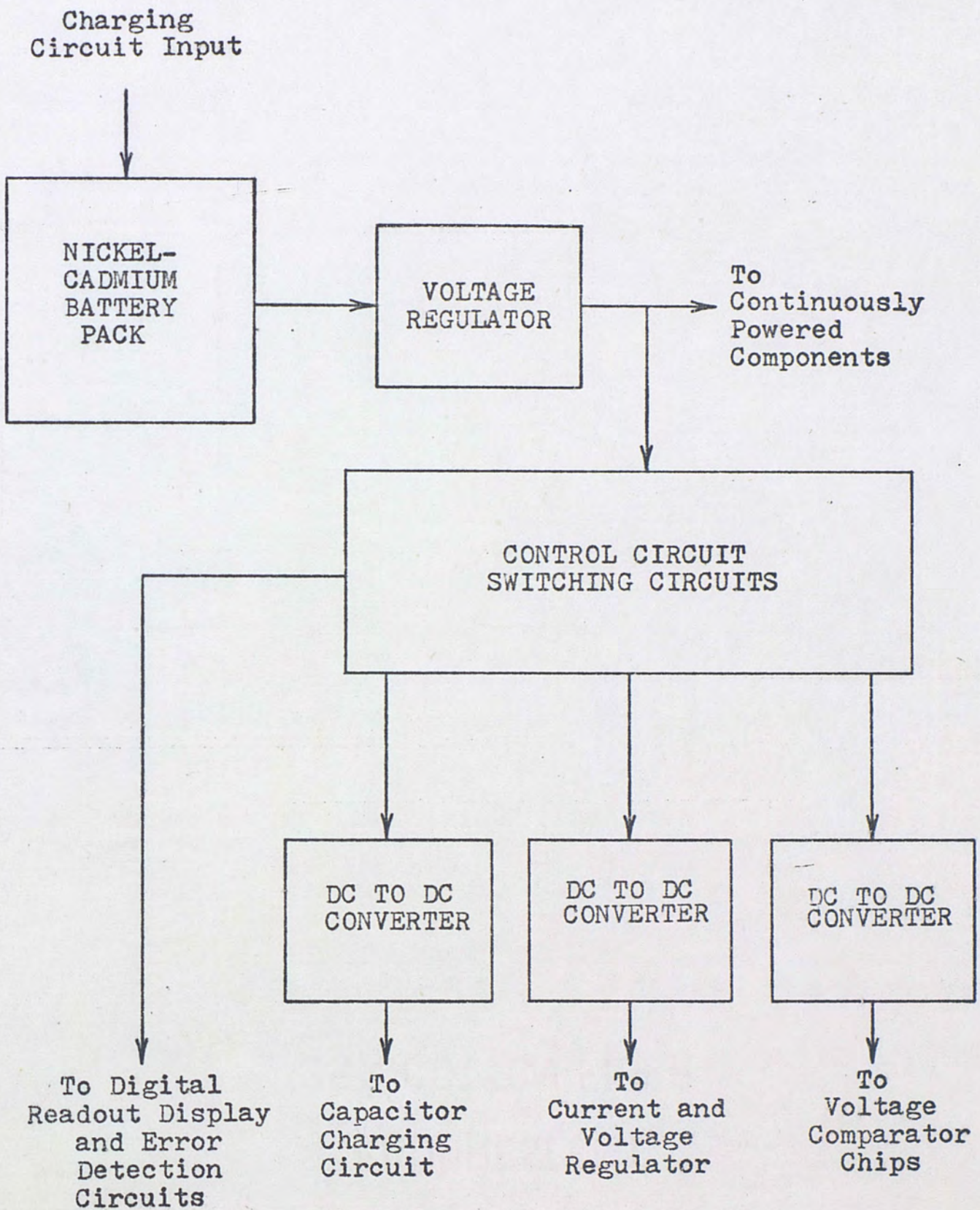

Figure 7. Power Supplies Block Diagram

ANALYSIS:

The design of the power supply section is a straightforward design and superfluous components were not included. The circuit does have one major deficiency; that is, the operator has no way of determining when the supply batteries are beginning to need recharging. Actual tests using the Model RT-2 Microhmmeter have indicated that the reading obtained with weak batteries tend to read high and the trend continues as the batteries become weaker. This means that several erroneous readings could be taken before the operator realized that the batteries need recharging.

One solution to this serious problem would be the inclusion of a clocked voltage comparator, timed to sample the battery voltage level during a high supply usage period. The output of this circuit should be connected to a warning light on the control panel to warn the operator of the need to recharge the batteries.



### CHAPTER III

#### RECOMMENDATIONS AND CONCLUSIONS

The Model RT-2 Microhmmeter has proven to successfully perform in applications where it is being used as the designer intended. Its portability has enabled users to easily move it about and even apply it to additional usages. One new use has been in checking the resistance of the aluminum bus bars used in switchyards to determine if all bolts in the mechanical connections of the bus bars have been torqued down and all mating surfaces properly cleaned.

The fact that the Model RT-2 Microhmmeter is such a portable device has pointed out one item that needs to be redesigned to further the usefulness of the portable microhmmeter. Attempts to use the microhmmeter to test circuit breaker contacts without disconnecting the secondary coil of the current transformer have resulted in a failure to obtain correct readings. This is due to the high current pulse failure to reach the 100 ampere level within the 65 milli-second time period, due to the longer time constant.

Even though the Model RT-2 Microhmmeter was not designed to be used on circuit breakers with the secondary cell of the current transformer loaded, the ability to do this would make the microhmmeter a more versatile piece of test equipment. It is suggested then that the design of the second generation portable microhmmeter be modified to provide a longer high current pulse. This could be accomplished in the following way.

The energy stored in a capacitor is defined by

$$W = \frac{1}{2} C V^2 \text{ joules}$$

Where, C is in farads and V is in volts.

As an example, to double the energy stored in the capacitor bank, either the capacitance must be doubled or the voltage increased by a factor of the square root of two. The capacitor bank in the microhmmeter consists of three 190,000 microfarad capacitors connected in parallel. The weight of the capacitors alone is 24% of the total allowed 25 pounds, and each capacitor is  $3\frac{1}{2}$  inches in diameter and 8 inches long. To double this capacitor bank would cause the microhmmeter to exceed the goals for weight and size.

The other alternative to doubling the energy stored in the capacitor is to increase the voltage by the square root of two. This would require charging the capacitor to 42.4 volts. To do this would require changing the DC to DC converter used in the capacitor charging circuit. In addition, the 190,000 microfarad capacitors now used are rated at 30 volts DC and these would have to be replaced with capacitors having higher voltage ratings for, as the voltage rating is increased, the maximum capacitance obtainable in a given size package drops.

Since test data has shown current pulses in the order of two to three seconds are required for some circuit breakers, the use of capacitors to supply the energy for the high current power supply is not practical. It is suggested then that the designer of the second generation pulse current microhmmeter consider using rechargeable nickel-cadmium storage batteries as the high current pulse energy source. These batteries have very small source resistances and are very lightweight. The cost of a battery source as opposed to the capacitor bank energy source is about doubled. However, if batteries are used, the following circuits now utilized in the Model RT-2 Microhmmeter would be eliminated:

1. The low current detection circuit in the capacitor charging circuit

2. The ready light and circuit
3. The automatic refresh circuit
4. The DC to DC converter used for charging the capacitor
5. The 150 millisecond timer used to deactivate the DC to DC converter during the test cycle.

The cost savings incurred by eliminating the DC to DC converter used in the capacitor charging circuit will more than offset the additional cost of the nickel-cadmium batteries.

In the design of the second generation microhmmeter by Alber Engineering, Inc., many of the recommended circuit changes presented in this paper have been incorporated into the new design. Included in those changes is the battery energy source for the high current power supply. Several of the second generation microhmmeters have been sold to the major circuit breaker manufacturers and are proving to be a very useful piece of test equipment.

It should be noted that the pulse current concept used in the Model RT-2 Microhmmeter and subsequent designs is being patented, with Formal Notice of Allowance having just been received.

## BIBLIOGRAPHY

- (1) American National Standards Institute. Test Procedure for AC High Voltage Circuit Breakers. ANSI C37.09. 1964.
- (2) James G. Biddle Company. Ducter R Low Resistance Ohmmeters. Bulletin 24. Plymouth Meeting, Pa. 1967.
- (3) Alber Engineering, Inc. Portable Micro-Ohmmeter Model RT-2. Product Description Sheet. Boca Raton, Fla.
- (4) Signetics. Signetics Linear Vol. 1 Data Book. The NE/SE 555 Monolithic Timing Circuit. Synnyvale, Calif. 1972.
- (5) Texas Instruments, Inc. The Integrated Circuits Catalog for Design Engineers. Series 54,74 Transistor-Transistor Logic. Dallas, Texas.
- (6) Motorola Semiconductor Products, Inc. MC1566L/MC1466L Monolithic Voltage and Current Regulator. Phoenix, Ariz. 1970.
- (7) Datel Systems, Inc. Digital Panel Meter Model DM-1000. Product Data Sheet. Canton, Mass.