

---

Retrospective Theses and Dissertations

---

1973

## A Solid State VHF Single Sideband Transmitter

Ermi Roos  
*University of Central Florida*

 Part of the [Engineering Commons](#)

Find similar works at: <https://stars.library.ucf.edu/rtd>

University of Central Florida Libraries <http://library.ucf.edu>

This Masters Thesis (Open Access) is brought to you for free and open access by STARS. It has been accepted for inclusion in Retrospective Theses and Dissertations by an authorized administrator of STARS. For more information, please contact [STARS@ucf.edu](mailto:STARS@ucf.edu).

---

### STARS Citation

Roos, Ermi, "A Solid State VHF Single Sideband Transmitter" (1973). *Retrospective Theses and Dissertations*. 71.

<https://stars.library.ucf.edu/rtd/71>

A SOLID STATE VHF SINGLE SIDEBAND  
TRANSMITTER

BY

Ermi Roos

B.S.E.E., Newark College of Engineering, 1966

RESEARCH REPORT

Submitted in partial fulfillment of the requirements  
for the degree of Master of Science in Engineering in  
the Graduate Studies Program of  
Florida Technological University, 1973

Orlando, Florida

## TABLE OF CONTENTS

Page

1.0 INTRODUCTION	1
2.0 PRINCIPLES OF ENVELOPE ELIMINATION AND RESTORATION SINGLE SIDEBAND	5
3.0 CIRCUIT DESCRIPTION	32
4.0 EXPERIMENTAL RESULTS	46
5.0 CONCLUSIONS	66
APPENDIX A - EFFECT OF FREQUENCY DIVISION OF THE PHASE MODULATION COMPONENT	71
APPENDIX B - EFFECT OF PHASE SHIFT IN THE ENVELOPE ELIMINATION AND RESTORATION SYSTEM	95
APPENDIX C - LINEAR AMPLIFICATION WITH CLASS C AMPLIFIERS	100
BIBLIOGRAPHY	104

## LIST OF FIGURES

	Page	
Figure 1	Voltage and Current Waveforms of a Class C Amplifier	16
Figure 2	Voltage and Current Waveforms of a Class A Amplifier	18
Figure 3	Basic Envelope Elimination and Restoration System	20
Figure 4	Proposed Solid State VHF SSB Transmitter	25
Figure 5	The Meinzer Method	28
Figure 6	SSB Generator	33
Figure 7	Signal Processor	36
Figure 8	Frequency Converter	38
Figure 9	Modulator	40
Figure 10	Transmitter	42

Figure 11	Power Supply	44
Figure 12	Balanced Modulator Output Test Setup	47
Figure 13	Frequency Spectrum of Balanced Modulator	48
Figure 14	Frequency Response Test Setup	50
Figure 15	Modulator Frequency Response	51
Figure 16	Transmitter AM Operation Test Setup	53
Figure 17	Transmitter Envelope for Single Tone Modulation	54
Figure 18	SSB Generator Output Test Setup	56
Figure 19	Frequency Spectrum of SSB Generator Output	57
Figure 20	Frequency Spectrum of Limiter Output	59

Figure 21	Frequency Converter Output Test Setup	61
Figure 22	Frequency Spectrum of Transmitter Output	63
Figure A1	Phasor Representation of AM (Single-Tone Modulation)	73
Figure A2	Phasor Representation of DSB-SC (Single-Tone Modulation)	73
Figure A3	Phasor Representation of SSB and "Pseudo-Carrier" (Two-Tone Modulation)	75
Figure A4	Phase Modulation Component of SSB (Two-Tone Modulation)	76
Figure A5	Phase Shift of SSB Phase Modulation Component (Two-Tone Modulation)	76
Figure A6	Frequency Spectrum of the Phase Modulation Component	81

Figure A7	Waveform of the Frequency Divider Output	85
Figure A8	Frequency Spectrum of Frequency Divider Output	93
Figure B1	Multiplication of RF and AF Components	98
Figure B1	Class C Linear Amplifier	101

## 1.0 INTRODUCTION

Single sideband (SSB) is a very old method of radio communication, and several decades of experimentation have resulted in a standard reliable method of generating SSB power. This is the classical "filter" method where a balanced modulator suppresses the AM carrier, a bandpass filter selects the desired sideband, a mixer selects the desired transmitter frequency, and a linear amplifier develops the required transmitter power. The earliest SSB transmitters were made in this manner, as well as the most recent ones.

This method of generating SSB has the undesired feature that high level sideband power cannot be generated directly, such as with AM, but must be developed with successive linear amplification. Linear amplifiers have low efficiency, are very susceptible to self-oscillation, and tend to generate intermodulation products. If transistors are used, the devices tend to go into "second breakdown" when they are forward biased sufficiently for good linearity. The "second breakdown" effect becomes more severe with increasing frequency, making the design of transistorized VHF SSB transmitters difficult.

A few methods of generating SSB power directly have been developed, but none has been very widely used. One is the



"phasing" method, where SSB power may be generated in a final balanced modulator. Such a scheme would be practical only in a single frequency transmitter, because the carrier phase shift network must be set as close to 90 degrees as possible, and networks that would track the carrier frequency would be difficult to adjust. Practical "phasing" transmitters, in fact, use mixers and linear amplifiers. The phasing circuit is simply used as a low-level single frequency SSB source. It is used as a means of eliminating the need for a bandpass filter with a high skirt factor, which was difficult and expensive to make years ago.

An interesting, but almost unknown, method of generating direct SSB was developed by O.G. Villard in 1948.<sup>1</sup> Villard took advantage of the fact that a narrowband phase modulated signal has sidebands that are identical to those of AM, but the carrier signal is 90 degrees out of phase with that of AM. By mixing a signal that is 90 degrees out of phase with the audio signal, with a signal that is phase modulated by the audio signal, one of the sidebands is suppressed. Unfortunately, the carrier remains, and one of the reasons for using SSB is to eliminate the need for generating carrier power. What is unique about Villard's method is that the mixing may be

---

<sup>1</sup>O.G. Villard, "Composite Amplitude and Phase Modulation," Electronics, November, 1948, pp. 86-89.

done by amplitude modulating a class C amplifier. The transmitter described in this paper uses a similar method of generating SSB power.

In 1952, Leonard R. Kahn wrote a paper describing the principles of amplifying SSB by envelope elimination and restoration.<sup>2</sup> With this scheme, a low-level SSB signal is infinitely limited, leaving only a phase modulated signal. The phase modulated signal is amplified to a high level with class C amplifiers. A portion of the original SSB signal is envelope detected, and the detector output is applied to an AM modulator that modulates the last class C amplifier. The class C amplifier output is a reproduction of the original SSB signal.

The object of this paper is to demonstrate that the Kahn method provides a practical means of designing a solid-state VHF SSB transmitter. This method exchanges increased complexity in low-level circuits for increased efficiency and ease of design and adjustment of the final power amplifier. Although Kahn's transmitter has not been popular in the past, it will be argued here that the relative cost between low-

---

<sup>2</sup>Leonard R. Kahn, "Single Sideband Transmission by Envelope Elimination and Restoration," Proceedings of the I.R.E., July, 1952, pp. 803-806.

level integrated circuits and high-level RF transistors justifies the use of complex low-level circuits, and simple RF power circuits.

The results of testing an actual envelope elimination and restoration transmitter will be described here. Since a standard VHF transmitter of comparable performance was not designed, strict comparisons between the two methods cannot be made. Nevertheless, the practicality of the envelope elimination and restoration technique will be demonstrated.

## 2.0 PRINCIPLES OF ENVELOPE ELIMINATION AND RESTORATION SINGLE SIDEBAND

### 2.1 Basic Theory

The generation of SSB power by envelope elimination and restoration is based upon the fact that any continuous wave modulated signal may be expressed as a product of the detected signal envelope and a phase modulation component. This may be expressed by the equation below.

$$f(t) = E(t)\cos[\omega_c t + \phi(t)] \quad (1)$$

Where  $E(t)$  is the envelope function,  $\omega_c$  is the carrier frequency,  $\phi(t)$  is the phase function, and  $\cos[\omega_c t + \phi(t)]$  is the carrier, or phase modulation component. By separating the envelope function from the phase modulation component, and amplifying the two signals separately, it is possible to recombine the signals in a high power mixer and reproduce the original composite signal.

The phase modulation component in Equation 1 may be isolated by multiplying  $f(t)$  by the inverse of the envelope function, which is  $\frac{1}{E(t)}$ .

$$\frac{f(t)}{E(t)} = \frac{E(t) \cos [\omega_c t + \phi(t)]}{E(t)} \quad (2a)$$

$$= \cos [\omega_c t + \phi(t)] = f_{PM}(t) \quad (2b)$$

In practice, multiplication by the inverse of the envelope component is accomplished with a zero-crossing detector, or an infinite limiter.  $f_{PM}(t)$  is amplified to the desired level using class C amplifiers, and then multiplied by a signal proportional to the envelope function,  $E(t)$ , to restore the original signal, (1).  $E(t)$  is obtained by AM detecting the continuous-wave modulated signal.

Multiplication of two signals is usually done by the use of a balanced modulator, but, in this case, a standard AM modulator is sufficient. This is because  $E(t)$  contains a DC component that prevents negative excursions of  $E(t)$ . A class C amplifier, which is suitable for amplifying  $f_{PM}(t)$ , may then also be used for multiplying  $E(t)$  with  $f_{PM}(t)$ .

Accurate restoration of the original signal depends upon correctly preserving the amplitude and time relationships of  $E(t)$  and  $f_{PM}(t)$ . Any errors in either signal will cause distortion in the restored signal.

## 2.2 Linear and Nonlinear RF Amplifiers

If an RF signal has no time-varying envelope, it may be amplified without distortion by either linear or nonlinear amplifiers. This is because all of the distortion products produced by nonlinearity will be centered around the harmonics of the carrier frequency, and they may easily be filtered out by conventional power amplifier tuned circuits. If a signal has an envelope, however, nonlinear amplifier gain will cause the envelope to amplitude modulate the desired signal, resulting in distortion products within the passband of the desired signal. These distortion products cannot be filtered out.

If either linear or nonlinear amplifiers may be used in an application, the nonlinear amplifier is the obvious choice. This is because all active devices are nonlinear by nature, and improvement in power gain linearity is usually obtained by sacrificing amplifier efficiency and increasing circuit complexity. Moreover, nonlinearity is actually required when the envelope function and phase modulation components are finally recombined.

## 2.3 Intermodulation Distortion as a Design Consideration

### 2.3.1 General

As with linear amplification, perfect reproduction of an SSB signal also cannot be obtained with the envelope elimination and restoration method. It is the purpose of this section to establish how much distortion is tolerable in a VHF SSB transmitter. It has been observed that the envelope of an SSB signal contains very little information, and the signal remains intelligible even if the envelope is infinitely limited. Distortion of the envelope, however, results in the production of intermodulation products. In commercial practice at HF frequencies, third-order products produced in a two-tone test are held at least 30 db below the level of one of the test tones. Because of the close channel spacing used at HF frequencies, third-order products may fall into an adjacent channel. In the VHF region, however, more frequency space is available, and the channels need not be spaced very close together. Currently, there are no commercial SSB frequency allocations above 50 MHz, and so, information about interference to adjacent channels cannot be obtained from actual experience. As a hypothetical example, it will be supposed here that AM transmitters were eliminated from the 118 through 136 MHz civil aircraft band, and SSB transmitters were used instead.

### 2.3.2 Practical Considerations in VHF SSB

At HF frequencies, maintaining a narrow bandwidth of transmission is very important because only a small portion of the spectrum is available for communications. At VHF frequencies, however, the stability of the transmitter and receiver is more important than the signal bandwidth in establishing channel spacing. This can be shown by comparing the 118 through 136 MHz aircraft band with the aeronautical mobile bands available at HF frequencies. The 118 through 136 MHz band covers a total of 18 MHz, which is an incredibly large bandwidth compared to the 2.25 MHz allocated for aeronautical mobile operations at HF frequencies. Moreover, the widest single aircraft band in the HF region is only .305 MHz wide. This is particularly important because the frequency band an airborne station will use is usually established by day-to-day propagation conditions. Thus, at any particular time, a large number of pilots may be operating within a single band, while the remainder of the 2.25 MHz will receive little use.

At the present time, 720 channels, spaced 25 kHz apart, have been assigned in the 118 through 136 MHz band. Considering that the maximum range of the transmitters used is approximately 200 miles, this number is more than adequate.



The Federal Communications Commission requires a frequency tolerance of .005% in the transmitters operating in this band, which means that the carrier frequency can deviate as much as 6.8 kHz at the high end of the band. The IF bandpass must be wide enough to receive any signal .005% away from the center of the desired channel. In determining the IF bandpass, the frequency stability of the receiver must also be taken into account. If both the transmitter and receiver have frequency tolerances of .005%, and no fine tuning is used in channel selection, the IF bandpass must be twice .005% the channel frequency in both directions from the center of the bandpass, plus the signal bandwidth. At 136 MHz, the total bandpass must be  $4 \times .00005 \times 136000 \text{ kHz} + 6.8 \text{ kHz}$ , or 33.2 kHz. If SSB were used, rather than AM, the required bandwidth would only be reduced to 30.2 kHz. This is much too wide for effective SSB operation, because the noise bandwidth is much greater than the signal bandwidth. The IF bandpass for SSB should be only 3 kHz. If tuning is done simply by channel switching, this would impose a severe restriction upon the frequency tolerance of the transmitter and receiver. Frequency stability would have to be in the order of one part per million. This is certainly possible, but difficult to achieve economically in an airborne transmitter and receiver. A better solution would be to maintain .005% frequency tolerance in both the transmitter and receiver, and to include fine

tuning in the receiver. The transmitter could generate a low-level pilot carrier so that the transmitter can be easily tuned in.

### 2.3.3 Calculation of the Intermodulation Distortion Specification

Let us consider the situation where an SSB transmitter is tuned to exactly 135.975 MHz, and a receiver is tuned to exactly 136.000 MHz. The transmitter is modulated with two equal-amplitude tones at 300 Hz and 3000 Hz, which is the widest frequency spacing possible in many SSB transmitters. The receiver has a bandwidth of 3 kHz. The frequency spacing between one of the test tones of the transmitter, and the edge of the receiver bandpass is  $25 \text{ kHz} - (2.7 \text{ kHz} \div 2) - (3.0 \text{ kHz} \div 2) = 22.15 \text{ kHz}$ . (It should be noted that the center of the bandpass of the SSB signal is not the carrier frequency, as in the case of AM, but the center of the transmitter power spectrum.) This means that a total of seven distortion products will appear in the unused frequency space between channels, and the eighth product will appear in the bandpass of the receiver. Because in-band distortion consists entirely of odd-order distortion products (the even-order products appear as harmonics and are filtered out by the tuned circuits of the transmitter), seventeenth order

distortion will appear in the bandpass of the receiver. Even if the transmitter signal is infinitely limited, the seventeenth-order product will be  $1/17$  of the level of one of the test tones, or 25 db down. This fact is demonstrated in Appendix A. This example shows that even the worst-case distortion will not cause severe interference in the adjacent channel under the conditions described. Of course, simply limiting and amplifying the SSB signal will not result in satisfactory operation. The transmission, though still intelligible, will be badly garbled, and the interfering signal should be 30 db down rather than only 25 db down, and it is the thirty-third order product that is that low. This product is 40.5 kHz away from one of the test tones.

If the linearity of the system were improved so that the seventeenth-order distortion is 30 db below one of the test tones, the third-order product need be only 15 db down. This is because the amplitude of a distortion product is usually proportional to its order, and the seventeenth-order product is  $3/17$  of the amplitude of the third-order product. This ratio is approximately -15 db. Since the seventeenth-order product is 30 db down, the third-order product need be only 15 db down.

Unfortunately, a reasonable amount of frequency tolerance must be allowed in the transmitters operating within the

band. This means that it will not be always possible to maintain the same amount of frequency space between channels as in the previous example. Let us suppose now that the transmitter that should be operating at 135.975 MHz is .005% of the channel frequency too high, and the receiver is tuned to a signal .005% of 136 MHz. below 136 MHz. There is now 13.6 kHz less unused frequency space between channels than there was before, or only 7.55 kHz. Two distortion products will be in the unused space, and the third will be in the adjacent channel. This will be the seventh-order product. If the seventh-order product is 30 db below one of the test tones, the third-order product will be 23 db down. This is because the ratio of the third-order product and seventh-order product is 7 db.

From the above discussion, it is concluded that the third-order distortion products in the transmitter being described, should be 23 db below one of the test tones in a two-tone test.

## 2.4 Second Breakdown in RF Power Transistors

### 2.4.1 General Description of Second Breakdown

Second breakdown is a phenomenon of transistors where high current concentrations become localized in hot spots within

the transistor pellet, and cause a regenerative effect where the transistor is unable to sustain the applied collector-to-emitter voltage. Destruction of the transistor usually results. What is particularly disturbing about second breakdown is that it may occur within the primary breakdown and dissipation ratings of a transistor.

While second breakdown can happen in any transistor, it primarily occurs in high-frequency power transistors with reactive loads. The hot spots occur when the transistor is drawing a large amount of collector current, with a high level of collector-to-emitter voltage. If a transistor has a purely resistive load, the peaks of the voltage waveform coincide with the troughs of the current waveform. This is because the transistor collector is a current sink, and its voltage goes down as it sinks more current. Thus, a transistor with a resistive load has a considerable amount of second breakdown protection. If the collector circuit has reactive elements, however, the collector voltage may be sustained at a high level when the collector current is at maximum. This is because the energy-storage elements would delay the collector voltage waveform from what it would be with a resistive load. Regardless of the type of load a transistor has, second breakdown may also be produced by DC biasing a transistor for high collector voltage and current.

The susceptibility of a transistor to second breakdown increases as its gain bandwidth product,  $f_t$ , increases. The formula for the current at which second breakdown occurs has been found experimentally to be

$$I_{sb} = K \frac{1}{\sqrt{f_t}}$$

where K is a constant applicable to a particular transistor.<sup>1</sup> VHF power transistors require an  $f_t$  of several hundred megahertz to operate effectively, and they are thus very susceptible to second breakdown.

#### 2.4.2 Second Breakdown in Class C and Linear Amplifiers

Figure 1 shows the collector voltage and current waveforms of a properly tuned class C RF power amplifier. Note that the current pulses occur only when the collector voltage is swinging to the minimum value. This phase relationship makes second breakdown very unlikely, and it occurs only if the collector load is resistive at the resonant frequency. If the amplifier is not perfectly tuned, the collector load will be reactive at the operating frequency, and there will be a phase shift in the collector voltage. Under severe

---

<sup>1</sup>RCA Power Transistor Manual (Sommerville, N.J.: RCA Solid State Division, 1971), p. 14.

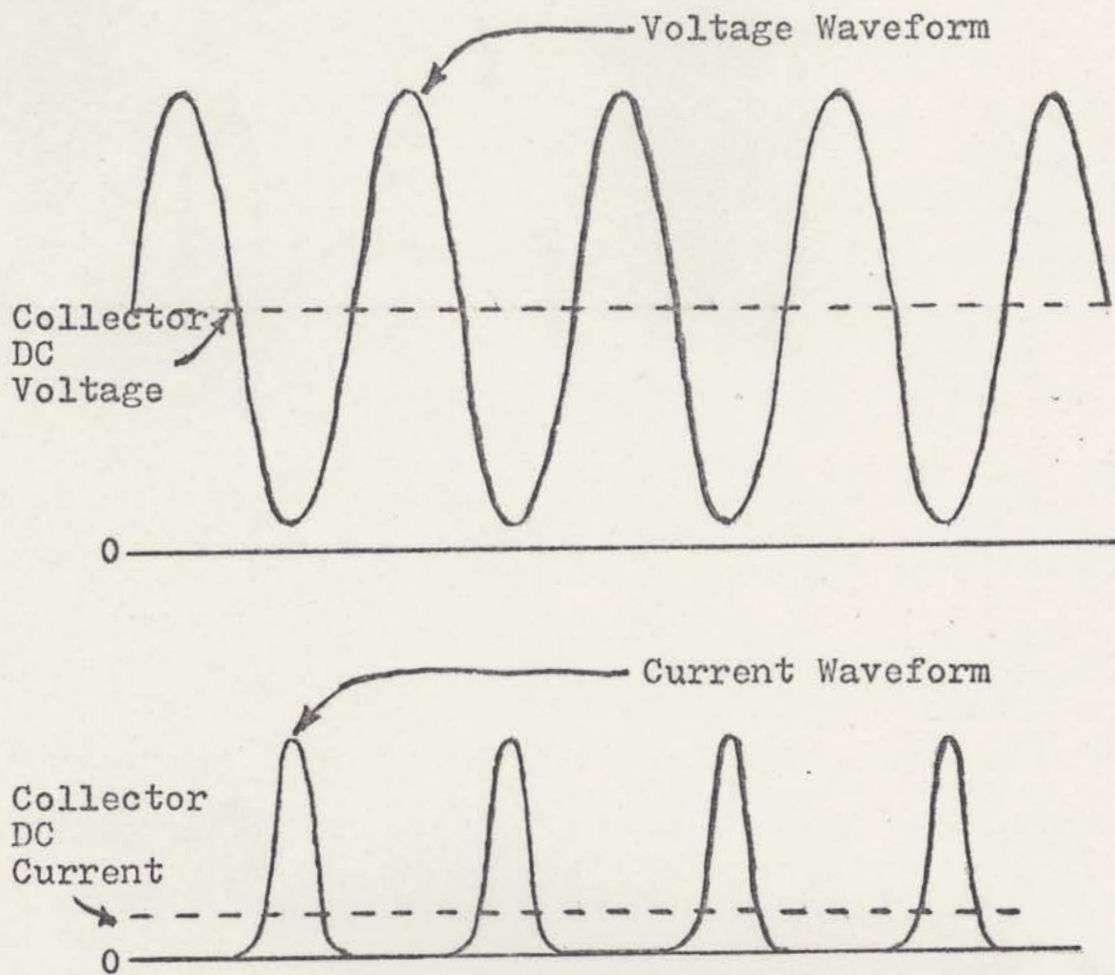

Voltage and Current Waveforms of a Class C  
Amplifier  
Figure 1

load mismatch conditions, the phase shift can be large, and both the voltage and current can be high simultaneously. This can cause second breakdown to occur. RF power transistors of the "overlay" type are designed to prevent the current concentrations that cause second breakdown. They have a large number of emitter sites with small integrated "ballast" resistors in each site. If a hot spot tends to develop at an emitter site, the ballast resistor will cause emitter degeneration which reduces the amount of current at the site.

Ballasting degrades the RF performance of a transistor, somewhat, by decreasing transistor gain and increasing saturation voltage. Therefore, the minimum amount of ballasting to ensure adequate second breakdown protection, should be used.

Figure 2 shows the voltage and current waveforms of a perfectly tuned class A linear amplifier. A transistor RF amplifier may also function in a linear fashion in the class AB mode. The voltage and current phase relationships of Figure 2 are the same as in Figure 1. The major difference between the two diagrams is the time duration of collector conduction. The longer conduction time of linear amplifiers causes the transistor to draw more current at high collector voltages. This makes second breakdown more likely. Poor load mismatch



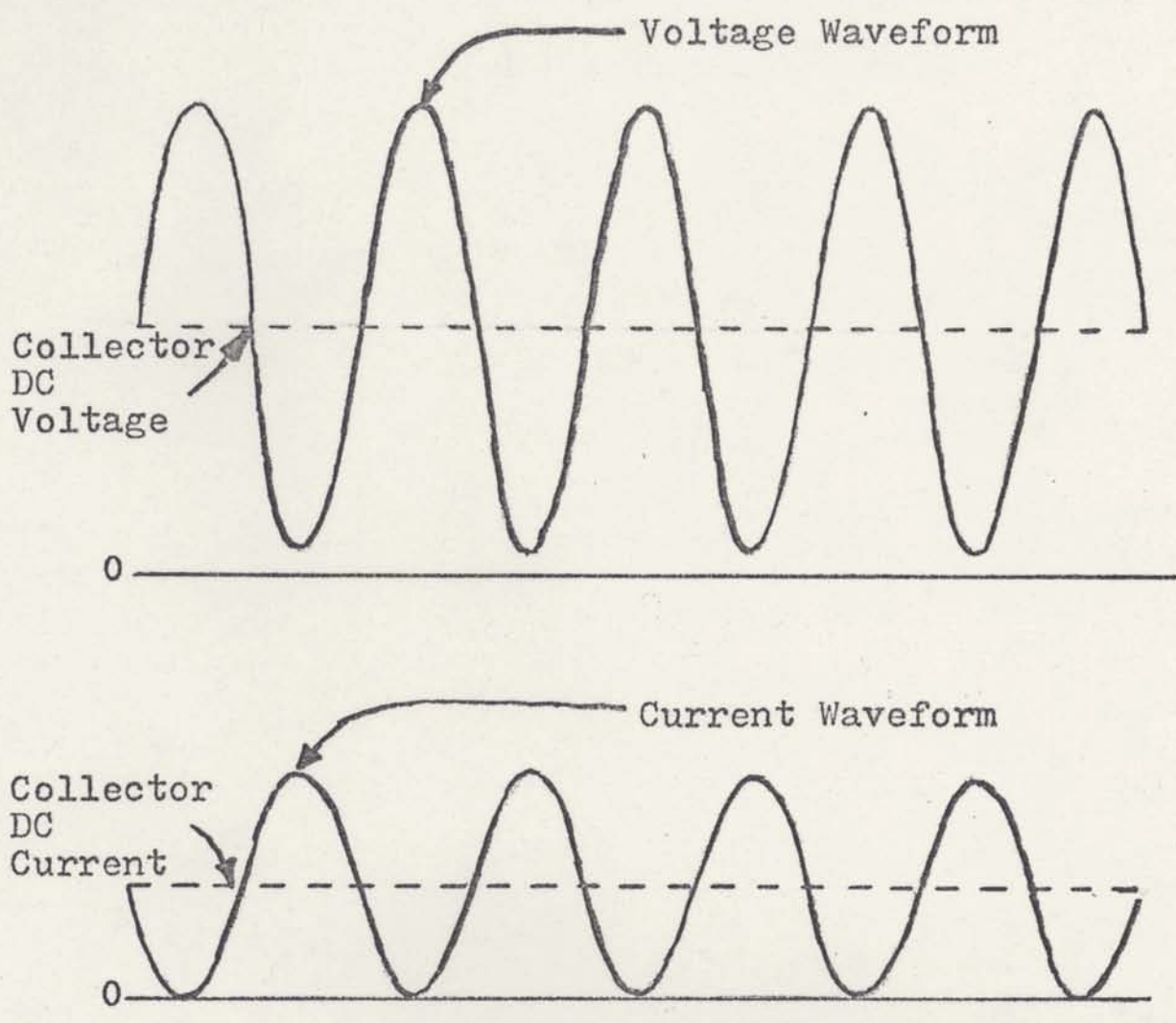

Voltage and Current Waveforms of a Class A  
Amplifier  
Figure 2

will have the same effect in linear amplifiers as in class C amplifiers, but with more severe results.

Special transistors have been designed for linear SSB operation in the HF region. They employ a large number of ballasted emitter sites, and they require high bias current for good linearity. The bias current has to be well regulated to prevent the destruction of the transistor. These transistors are only suitable for use up to 30 MHz.

## 2.5 The Basic System

Figure 3 shows the basic envelope elimination and restoration system as described by Kahn in his classic paper.<sup>1</sup> The output of the SSB Generator is limited, leaving a phase modulated signal. The Mixer and Oscillator establish the transmitting frequency of the system. The phase modulated signal is amplified to the desired level by a series of class C amplifiers. At the same time, the output of the SSB Generator is envelope detected, amplified, and applied to an AM modulator. The modulator and last class C amplifier mix the phase modulation and envelope components of the original SSB signal, and the output of the amplifier is a reproduction of

---

<sup>1</sup>Kahn, op. cit.

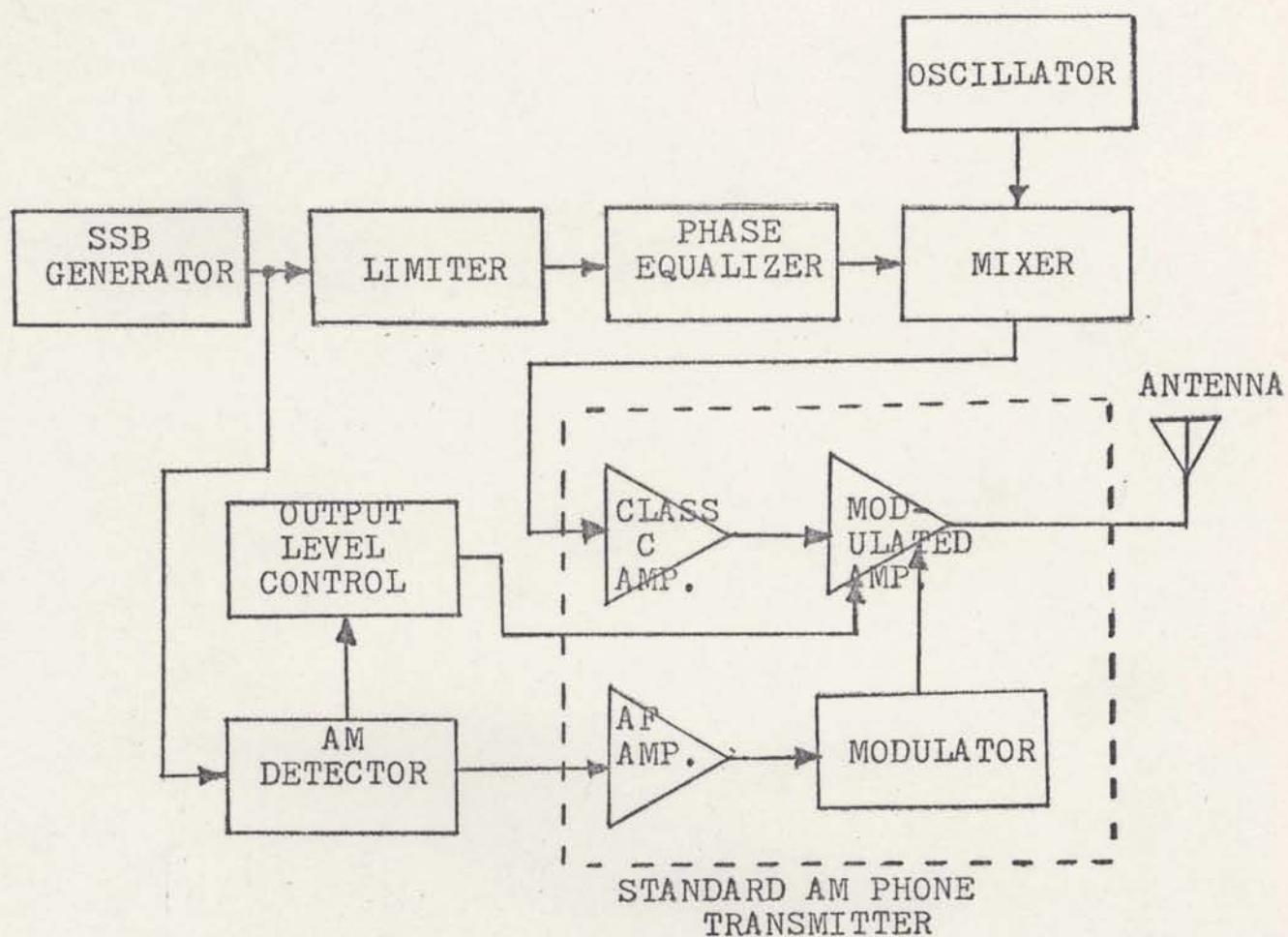

Basic Envelope Elimination and Restoration System

Figure 3

the SSB Generator output.

A particularly appealing feature of the Kahn method is that an AM transmitter can be used to generate SSB. It appears, at first glance, that SSB power can be generated with the same ease as AM. Unfortunately, this is not the case. There are fundamental differences between the envelopes of AM and SSB that cause difficulties in the implementation of the system.

AM has constant average power, and therefore, its detected envelope has a constant DC level. For this reason, AM modulators may be AC coupled to the modulated amplifiers, because the level of the DC component (i.e., carrier power) may be established by a DC power supply. AC coupling cannot be used with SSB, however, because its average power changes rapidly with time. For this reason, the Modulated Amplifier in Figure 3 is modulated by two separate signals that are derived from the detected SSB envelope. One signal is the Modulator output, which is transformer coupled to the plate of the final power amplifier tube. This signal contains the AC component of the envelope detector output. The other is a DC voltage that follows the DC level of the envelope detector output. The Output Level Control contains a low-pass filter that eliminates the AC component of the envelope, and a DC amplifier that applies a signal that is

proportional to the average level of the envelope to one of the grids of the final power amplifier tube.

One difficulty with using two modulation paths is ensuring that the two signals complement each other well enough so that the detected envelope is accurately reproduced. The levels have to be carefully balanced, and the upper cutoff frequency of the Output Level Control should be the same as the lower cutoff frequency of the Modulator. If a transistorized RF power amplifier is used, only a single modulation path is necessary, because a modulator can be readily DC coupled to the final power amplifier.

In order to accurately reproduce SSB, the AM transmitter must be capable of 100 percent downward modulation. This is because the SSB envelope frequently crosses zero. 100 percent modulation is easier to obtain with tube transmitters than with transistorized transmitters. This is because the drive power of a transistor can feed through to the output even if the collector voltage is zero. By modulating several stages at once, however, a high percentage of modulation can be obtained.

The Phase Equalizer in Figure 3 is intended to balance the time delays between the phase modulation component and envelope component during signal processing so that the original SSB signal is faithfully reproduced once the two com-

ponents are recombined. The Phase Equalizer, however, is shown in the wrong place in the diagram. It should be located between the AM Detector and AF Amplifier. Kahn was probably aware of this, but failed to pick out the error on the printer's proof sheets. To prove that the Phase Equalizer should be in the AF path rather than the RF path, Appendix B will show that the phase delay in the RF path will not cause any distortion in the recombined SSB signal.

Modulators containing transformers and coupling capacitors have appreciable phase delays that can cause spurious outputs in the envelope elimination and restoration system. These delays must be equalized. The need for phase equalization is eliminated if the modulator has a sufficiently wide frequency response so that there are no appreciable phase delays within the passband of the detected envelope. This means that the modulator must be flat well into the supersonic range. This was not possible with vacuum tube modulators, but can be easily done with integrated operational amplifiers.

Another important consideration in the envelope elimination and restoration system is the linearity of the modulator. AM transmitters function well even if the envelope of the transmitter output is not a good reproduction of the audio signal applied to the modulator. This is not the case with

the system under consideration. Nonlinearities in the modulation would cause spurious frequencies in the transmitter output.

## 2.6 The Proposed System

### 2.6.1 General

Figure 4 contains a block diagram of the proposed experimental solid-state VHF transmitter. It has an operating frequency of 146 MHz, and it is capable of developing 4 watts PEP. A transistorized AM transmitter is used as the modulated power amplifier. The Modulator is DC coupled to the Transmitter, and therefore, no "output level control" is necessary. The Modulator also has a sufficiently wide frequency response so that no phase equalization circuits are needed in the system.

The proposed system uses a unique frequency conversion technique that eliminates the need for multiple mixer-oscillator circuits. Because the output of the Limiter is a phase modulated signal, it may be frequency multiplied or divided without any distortion in the transmitted information. Only the modulation index changes by the factor of the frequency multiplication. Figure 4 shows that the 9 MHz output of the Limiter is divided in frequency by three to

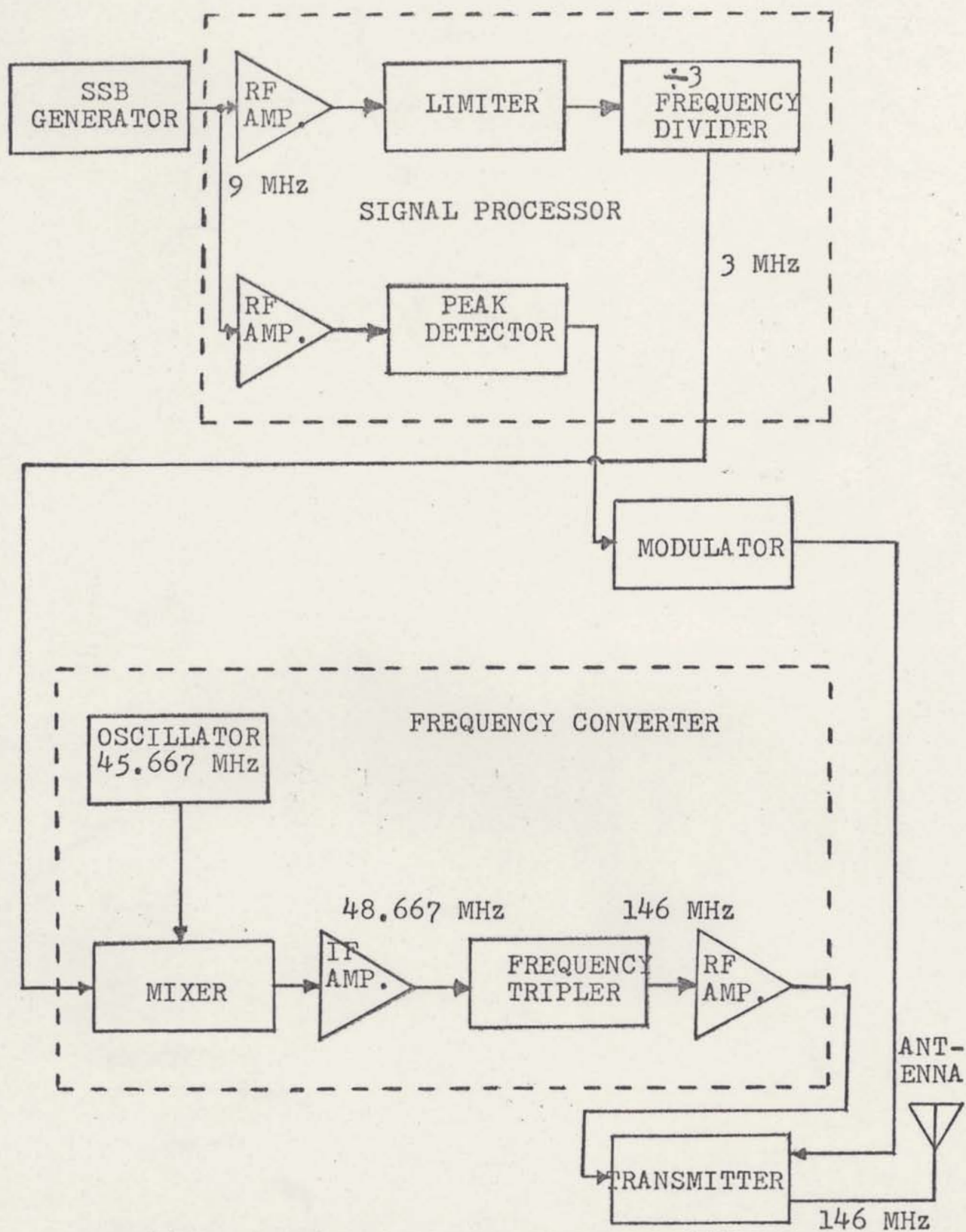

Proposed Solid State VHF SSB Transmitter

Figure 4



give a 3 MHz phase modulated output. The modulation index of the Frequency Divider output is one third that of the Limiter. Frequency tripling the IF Amplifier output results in a 146 MHz signal that has the same modulation index as the Limiter output. Thus, the 9 MHz Limiter signal is frequency converted to 146 MHz by the use of only a single mixer--oscillator circuit. A system similar to this was proposed by Karl Meinzer in 1970.<sup>1</sup>

The experimental transmitter was designed only to demonstrate the new technique, and not for any particular practical application. For this reason, the transmitter was made as simple as possible, and contains no circuits that are designed only for operator convenience. The use of only a single frequency of operation particularly helped to simplify the design. The use of 146 MHz places the operating frequency at the center of the 2-Meter Amateur Band. This frequency is far from the normal activity on the band, and allows unlimited testing of the transmitter without harmful interference to others.

---

<sup>1</sup>Karl Meinzer, "A Frequency Multiplication Technique for VHF and UHF SSB," QST, October, 1970, pp. 32-35.

## 2.6.2 The Frequency Converter

The frequency conversion technique presented here is similar to one described by Karl Meinzer in an amateur radio magazine.<sup>1</sup> Meinzer's total system deviates considerably from the one developed by Kahn. Figure 5 shows that modulation is not applied to the final power amplifier, but to the Frequency Divider output. This signal is then applied to a Mixer-Oscillator that heterodynes the signal to one third the desired frequency of operation. A Linear Amplifier develops the signal to a higher power level, and a varactor Frequency Tripler generates SSB power at the desired operating frequency.

This sort of transmitter must have a high level of intermodulation distortion because a varactor frequency tripler is certainly not a linear amplifier. Nevertheless, Meinzer reports that his signal was perfectly intelligible, and the third-order intermodulation products were 25 db down. Apparently, the varactor tripler followed the envelope of its input signal remarkably well. Meinzer operated his transmitter at 1296 MHz, where interference to adjacent channels is not a problem (largely because there is very little

---

<sup>1</sup>Ibid.

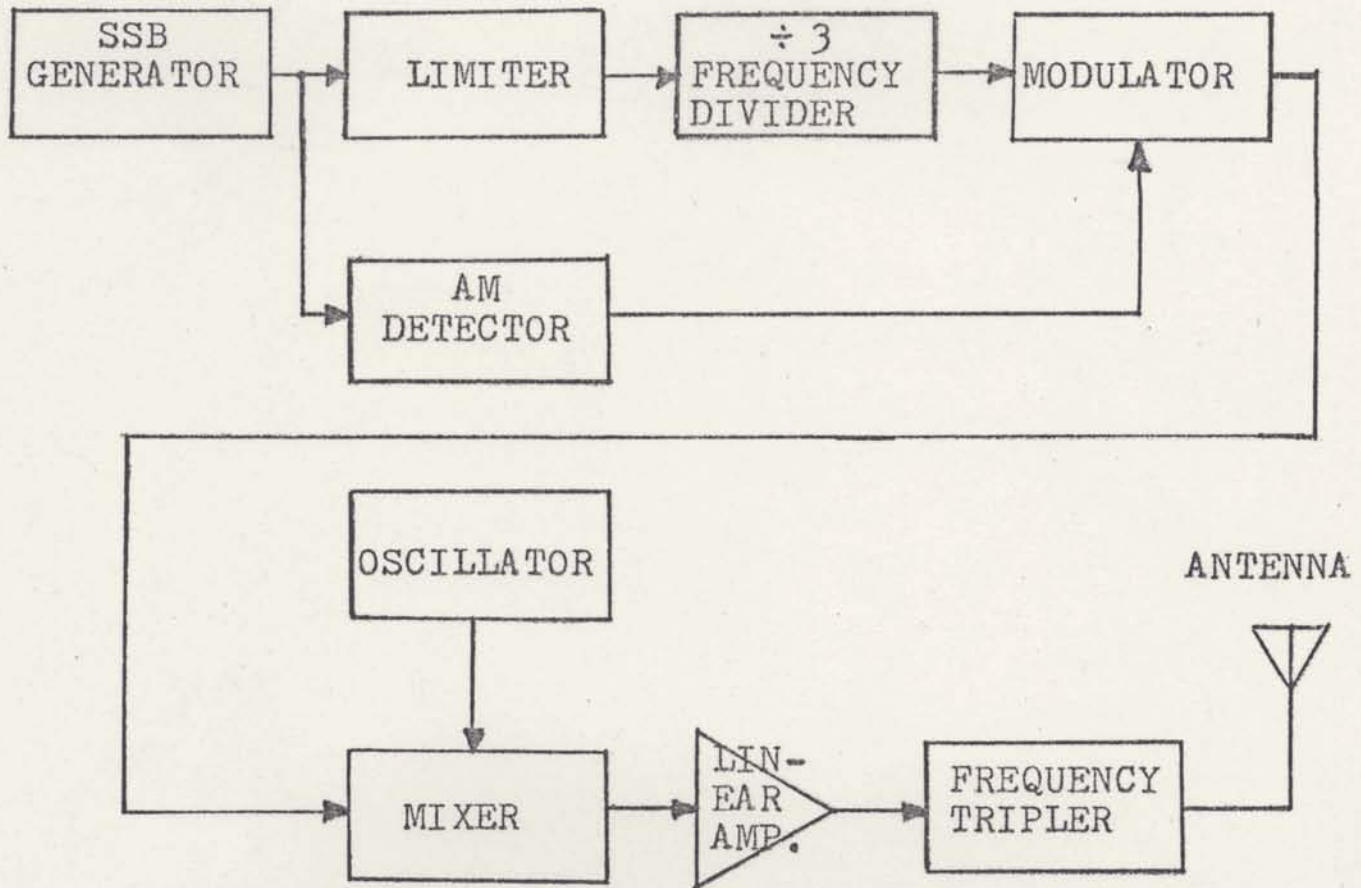

The Meinzer Method

Figure 5

activity at these frequencies). The transmitter described in this paper makes use of the frequency division-tripling idea, but AM modulation is still applied to the power amplifier, as in Kahn's transmitter.

The advantage of first dividing the phase modulation component by three, and finally tripling it, may not be obvious at first, but a little thought will reveal that it is easier to heterodyne a 3 MHz signal to 48.667 MHz, than a 9 MHz signal to 146 MHz. The ratio of the oscillator frequency ( $f_o$ ) to the input signal frequency ( $f_s$ ) remains the same in both cases, but suppression of undesired mixer products is easier at the lower frequency than the higher. An important mixer product that must be suppressed is the oscillator signal, or carrier. In an unbalanced mixer, the carrier level is normally much higher than that of the desired signal. With the  $f_o/f_s$  ratio used here,  $f_o$  is very close to the desired output signal, and a considerable amount of filtering is ordinarily required to attenuate the carrier. The best solution would be to make a balanced mixer that would suppress the carrier. Obtaining effective carrier balance is very difficult at 146 MHz because the phase shifts due to reactive elements in transistors are appreciable at this frequency, but a considerable amount of carrier suppression is easily obtained at 48.667 MHz. Another problem is that the third-order mixing product,  $f_o + 2f_s$ , is just as close to the

desired signal as the carrier. This product can only be eliminated by good filtering. Tuned circuits are more effective at 48.667 MHz than 146 MHz, because there are less losses due to skin effect and radiation, and higher Q's are possible.

In order to obtain a complete understanding of the system requirements of the frequency converter, the output of the Frequency Divider for a two-tone modulated SSB signal, is calculated in Appendix A.

### 2.6.3 The Transistorized Transmitter

A class C RF power amplifier is used to develop SSB power in the experimental transmitter. The advantages of using class C amplifiers to generate SSB, rather than class A or AB amplifiers, have been pointed out earlier in this paper. It should be stated here that it is not necessary to modulate the collector to obtain linear amplification with class C amplifiers. A sort of base modulation is now used in transistor linear amplifiers for AM operation in the 225 to 400 MHz military aircraft band.<sup>1</sup> A feedback control system is

---

<sup>1</sup>Russel A. Gilson "A Simple High-Performance Feedback Modulation System." Research and Development Technical Report ECOM-3224 (Fort Monmouth, N.J.: United States Army Electronics Command, January, 1970).

used, which is similar to the automatic level control (ALC) systems now used to correct nonlinearities in SSB linear amplifiers. The dynamic range and gain of this feedback system is much greater than that of ordinary ALC, because the nonlinearities of class C amplifiers are much more severe than those of amplifiers already designed for linear operation. The nonlinearities are corrected by modulating the input of the final power amplifier with the error signal of the feedback system.

This system is used for AM, which does not have as critical linearity requirements as SSB. It is capable of only up to 85% modulation, while the SSB envelope has 100% downward modulation. The system also requires an appreciable amount of drive power which must be generated by linear amplifiers at the operating frequency. Further details of this system are given in Appendix C.

## 3.0 CIRCUIT DESCRIPTION

### 3.1 General

This chapter contains an explanation of the circuits used in the experimental transmitter. The schematic diagrams (Figures 6 through 11) are divided into sections that correspond to the blocks in Figure 4.

Such incidental circuits as DC power line filters, and other circuits used to suppress interference within the system, have been omitted from the discussion.

### 3.2 SSB Generator

The SSB Generator (Figure 6) is the source of the low-level SSB signal that is frequency converted and amplified by the transmitter described in this paper. Oscillator Q1 develops the carrier signal used by the SSB Generator. It has an operating frequency of 8.9985 MHz, and it is applied to Balanced Modulator U1. An audio signal from a microphone is applied to U2, which acts as a high input impedance buffer amplifier for the microphone. U2 has unity voltage gain. Voltage amplification is obtained with U3, and the gain is adjusted by R12. DC offset of U3 is adjusted with R20.

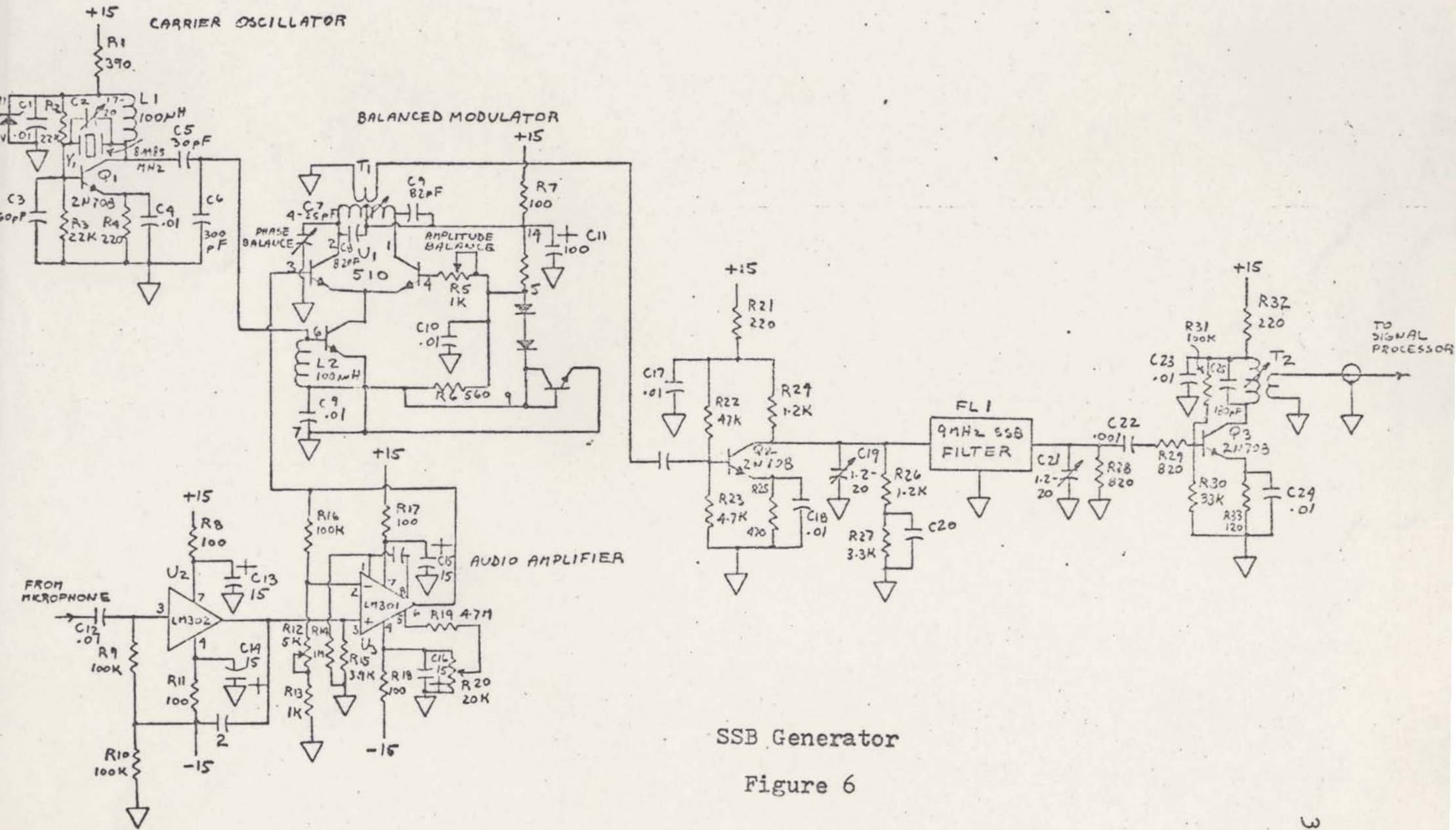

SSB Generator  
Figure 6



The output of U3 is applied to Balanced Modulator U1, along with the output of the Carrier Oscillator. The output of U1 consists of the sum and difference frequencies of the Carrier Oscillator and Audio Amplifier signals. In order to obtain good carrier suppression, U1 is provided with both amplitude balance and phase balance adjustments. Potentiometer R5 is used to adjust the amplitude balance, and trimmer capacitor C7 is used to adjust the phase balance.

Crystal filter FL1 is a narrow-band SSB filter that selects the upper sideband of U1 and rejects the lower sideband. FL1 has a bandwidth of 2.7 kHz and a center frequency of 9 MHz. C2 on the Carrier Oscillator is adjusted to set the carrier frequency to approximately the 20 db attenuation point of the lower skirt of the crystal filter. Transistors Q2 and Q3 serve as buffer amplifiers for FL1, and maintain the correct terminal impedance of the filter. In order to obtain the correct filter response, the input and output of the filter must be terminated with 600 ohms and 25 pF in parallel. The resistive termination is set by resistors R24, R26, R28, and R29. The capacitive termination is set by C19 and C21. The remainder of the required capacitance is supplied by stray capacitances in the circuit. The output of Q3, which has a power level in the order of 3 mw, is applied to the Signal Processor.

### 3.3 Signal Processor

The Signal Processor converts the output of the SSB Generator into its envelope and phase modulation components. The phase modulation component is also divided in frequency by three in the Signal Processor.

Figure 7 shows that the SSB Generator output is first applied to U1, which contains independent IF amplifier and envelope detector circuits within a single integrated circuit package. The IF amplifier output is amplified to a swing of 30 volts p-p by Q1. The output of the SSB Generator is also envelope detected by U1, and the detector output is applied to the Modulator.

Q1 has sufficient gain to clip most of the envelope of the SSB signal, and further clipping is done by the circuit formed by C14, CR1, CR2, and CR3. The output of this diode network is a constant-amplitude signal that swings between zero and 5.1 volts. The clipper output is connected to emitter-follower Q2. The output of Q2 is the phase-modulation component of the SSB Generator signal.

The phase modulation component is divided in frequency by three, by U2, which contains a pair of TTL J-K flip-flops. U2 is wired in a frequency divider configuration. Q3 con-

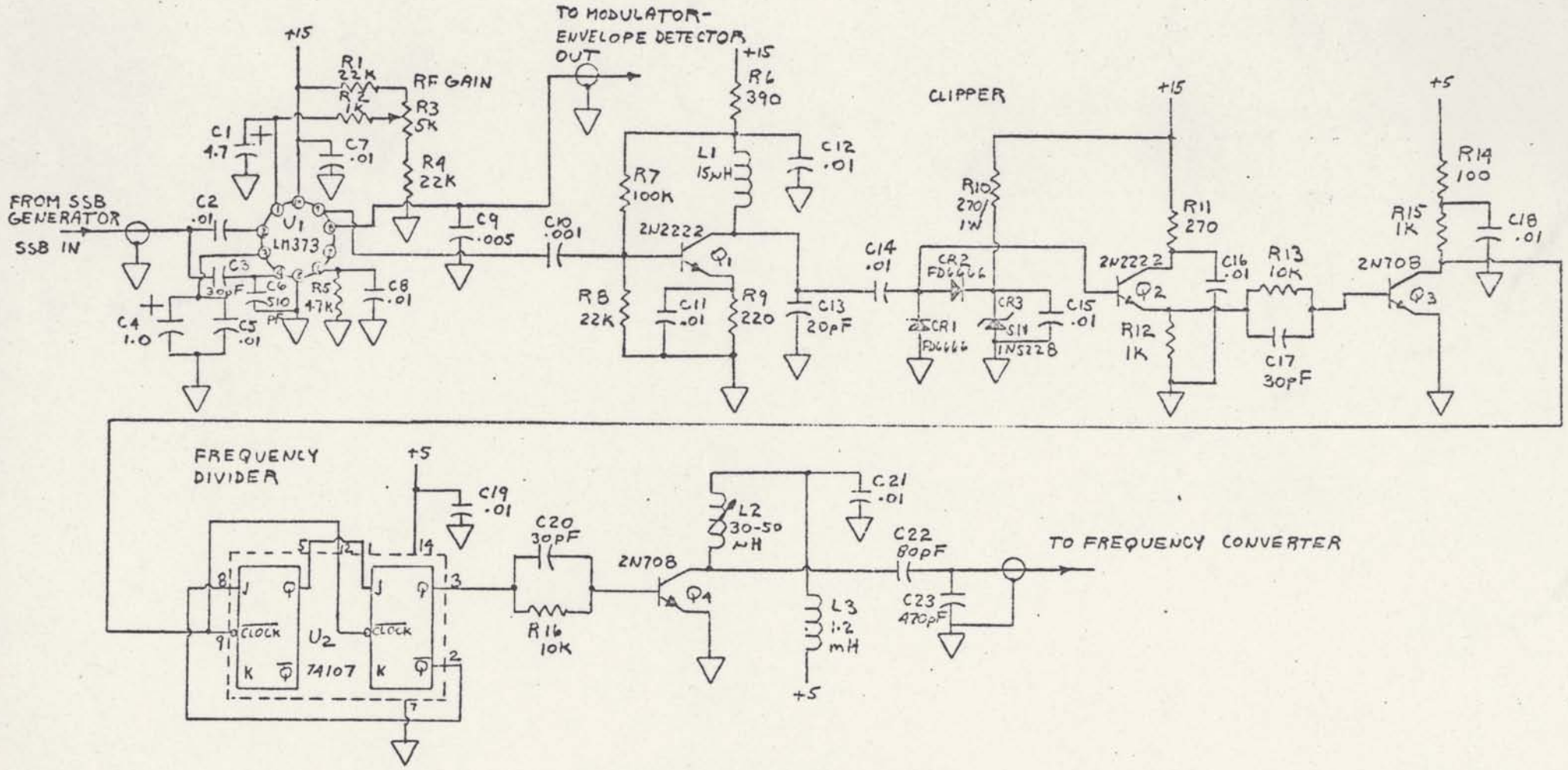

Signal Processor

Figure 7

verts the output of Q2 to the appropriate logic levels needed for operating TTL circuits. The output of U2 is applied to tuned amplifier Q4, which filters the signal from U2 and applies it to the Frequency Converter.

### 3.4 Frequency Converter

The Frequency Converter (Figure 8) converts the 3 MHz output signal from the Signal Processor to 146 MHz, and multiplies the modulation index of the signal by three.

The 3 MHz Signal Processor signal is applied to Doubly Balanced Mixer, U1. The output of Oscillator, Q1, is also applied to the balanced mixer. Carrier balance is achieved by adjusting potentiometer R11. U1 converts the frequency of the Signal Processor output to 48.6666 MHz, which is the sum of the 45.6666 MHz Oscillator frequency, and the 3 MHz Signal Processor output.

The mixer output is amplified by the IF Amplifier strip made up of U2 and U3. U2 and U3 are integrated transistor arrays wired as differential amplifiers. Q2 triples the 48.6666 MHz IF Amplifier frequency to 146 MHz. This also has the effect of tripling the modulation index of the Signal Processor output. A cascode amplifier made up of Q3 and Q4 amplifies the Frequency Tripler output to approximately 10 mw,

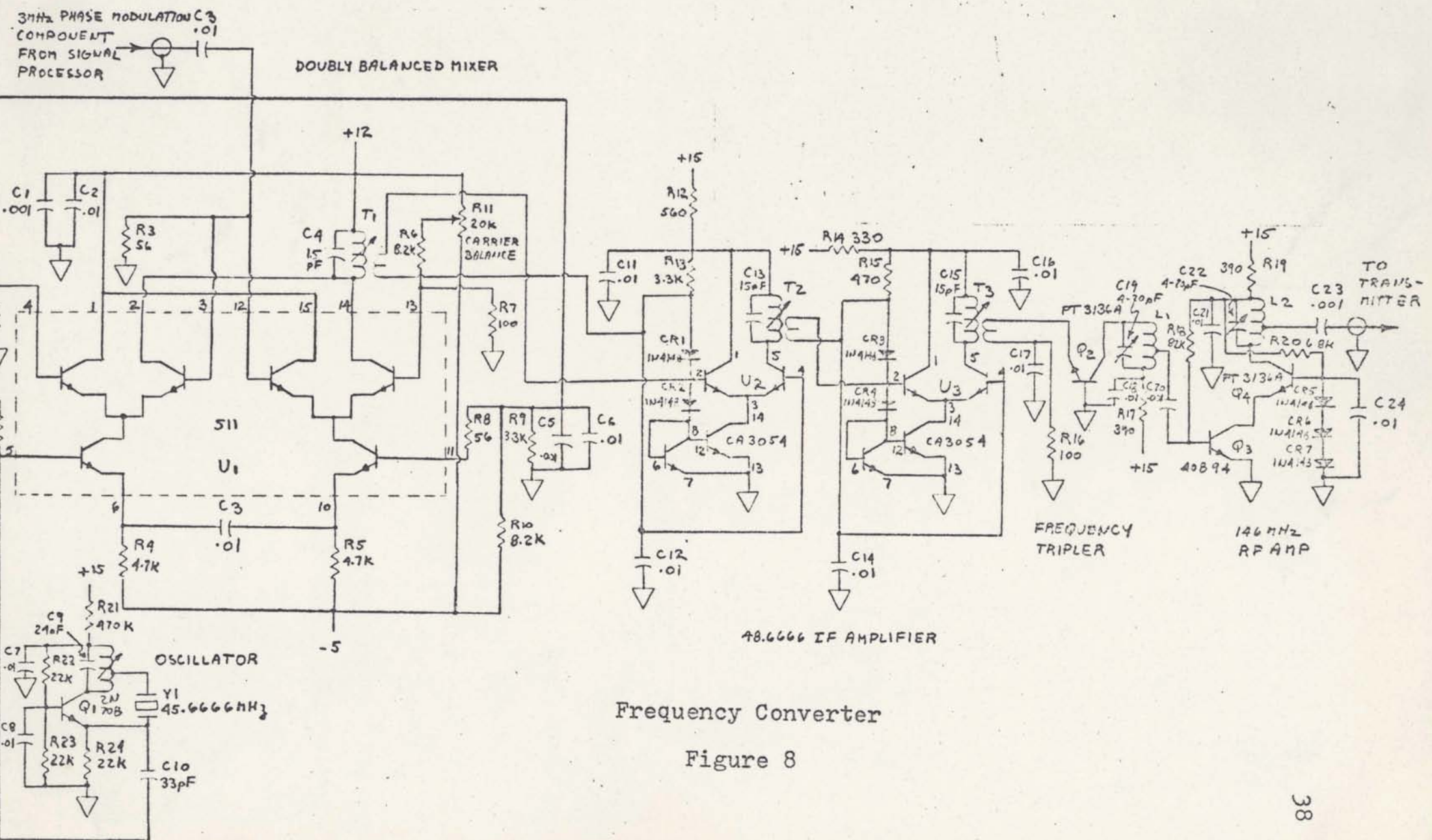

which is a level useable by the Transmitter.

### 3.5 Modulator

The Modulator (Figure 9) amplifies the envelope detector output of the Signal Processor and applies it to the Transmitter.

The Modulator circuit has three stages of voltage amplification provided by U1, U2, and U3, and a single stage of power amplification provided by U4, Q1 and Q2.

DC coupling is used throughout the Modulator, and potentiometers R1 and R13 establish the DC level of the output. The Signal Processor demodulator output has approximately 4 VDC offset voltage, and R1 is used to cancel out this voltage. R13 has less effect upon the output DC level than R1, and it is used for fine adjustment of the output DC level.

The LM305 operational amplifier (U4) is primarily used as a voltage regulator, but it is used as a power amplifier in this application. Transistors Q1 and Q2 are tied into the feedback loop of U4, and they greatly increase the power handling capabilities of the operational amplifier. The high gain of U4 ensures that the power amplifier output is linear.

Because DC coupling is used throughout the Modulator, the

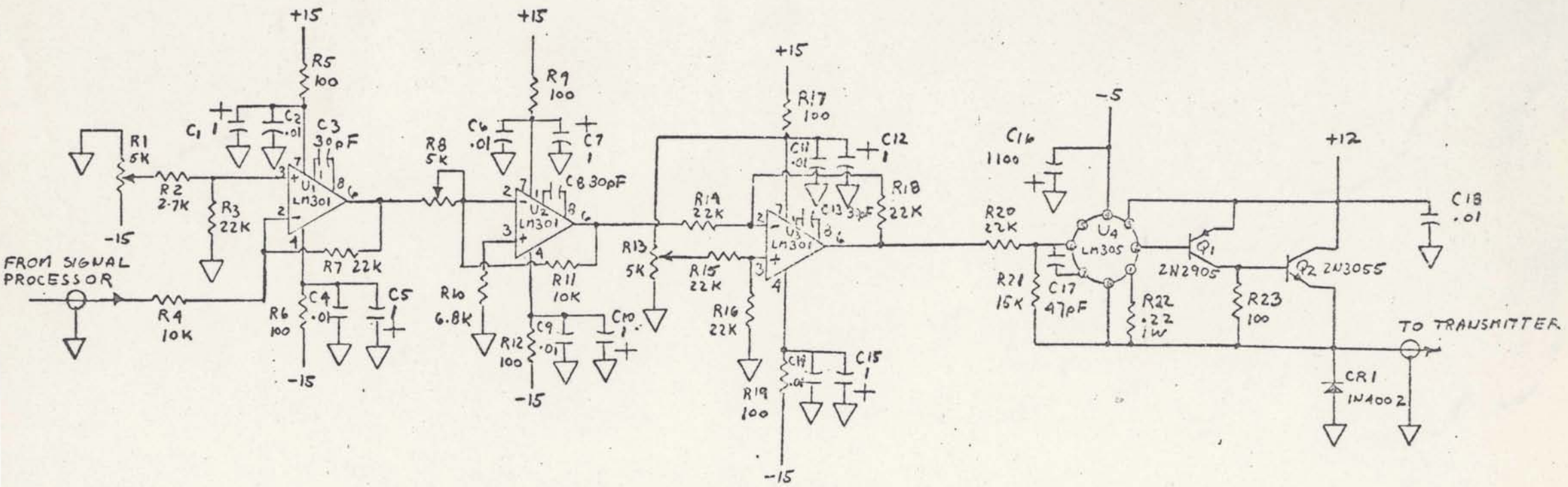

Modulator

Figure 9

frequency response is limited only by the operational amplifiers used in the circuit. The half power rolloff point is approximately a decade higher than the upper limit of the audio frequency band of interest, and this ensures minimum phase shift within the desired bandpass.

Diode CR2 prevents negative excursions of the Modulator output, which could damage the Transmitter transistors.

### 3.6 Transmitter

The Transmitter (Figure 10) amplifies the output of the Frequency Converter and mixes it with the Modulator output to form a VHF SSB signal.

The Transmitter consists of a seven stage RF power amplifier that amplifies the low-level output of the Frequency Converter to 4 watts PEP. The first six stages were made from the circuit of a Bendix RT-221 VHF Airborne Transmitter. The Bendix transmitter, which was designed for AM operation in the 118 to 136 MHz aviation band, was re-tuned for operation at 146 MHz. This conversion caused appreciable rolloff of the power output of the transmitter, and an external power amplifier, Q7, was added to the circuit.



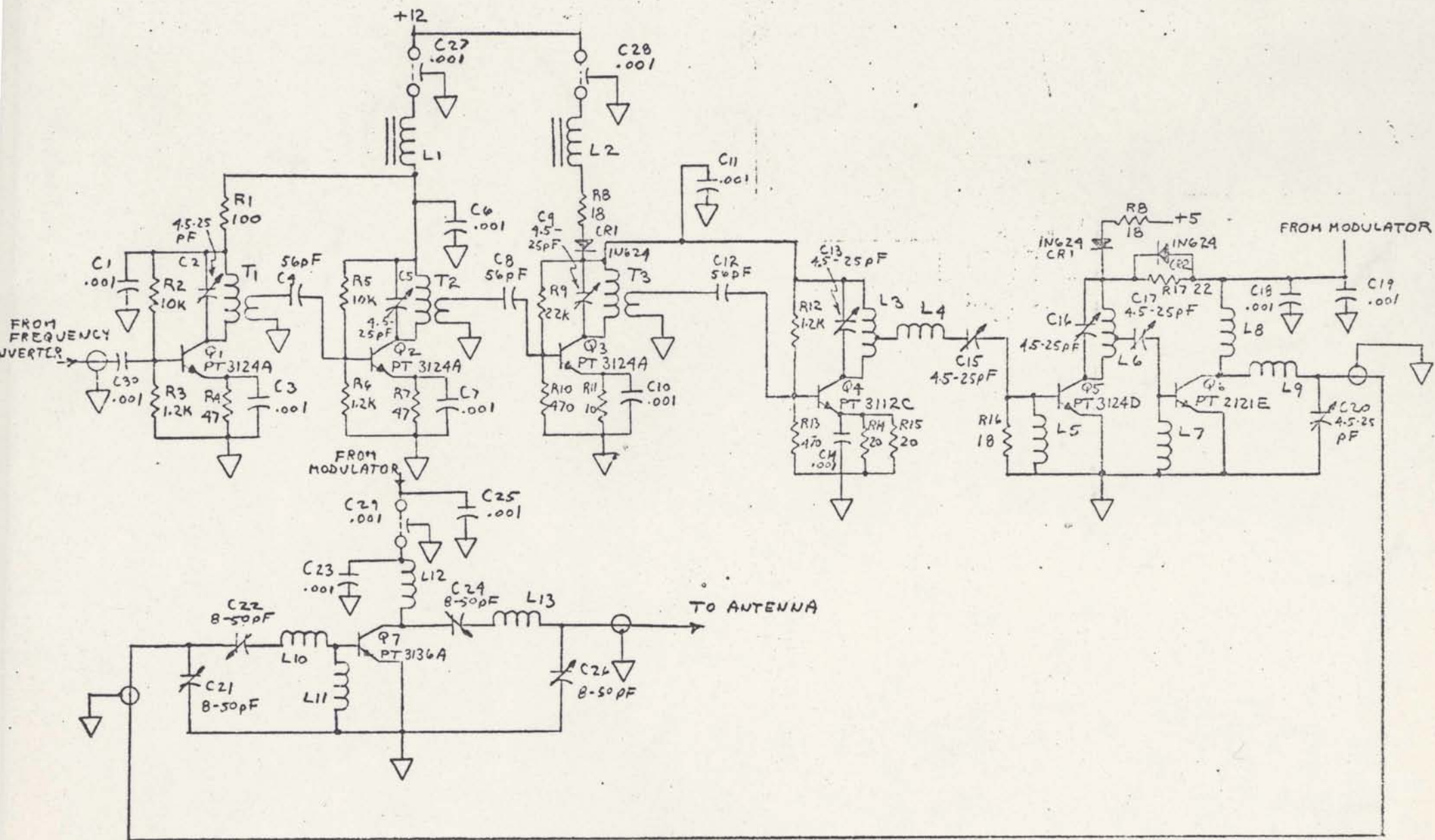

Transmitter

Figure 10

Q6 and Q7 are collector modulated by the Modulator output. Q5 is also collector modulated, but only in the upward direction. This prevents instabilities caused by the loss of drive power at negative modulation peaks, and helps to maintain good envelope linearity. Diodes CR1 and CR2 ensure that only positive modulation occurs in this transistor. Several stages are modulated simultaneously because RF power transistors tend to feed power through from the base to the collector, and are therefore limited in downward modulation capability.

The entire Transmitter loses drive power when no SSB signal is being generated, and the circuit must be carefully tuned to ensure that no instabilities occur under these conditions. The input and output impedances of RF power transistors vary with power level, and this makes the stability problem difficult. The neutralization methods used with vacuum tube RF power amplifiers are ineffective with transistor amplifiers.

### 3.7 Power Supply

The Power Supply provides all of the voltages required for operating the experimental system. Figure 11 shows that the same basic voltage regulator circuit, which is centered around the LM305 operational amplifier, is used to supply all

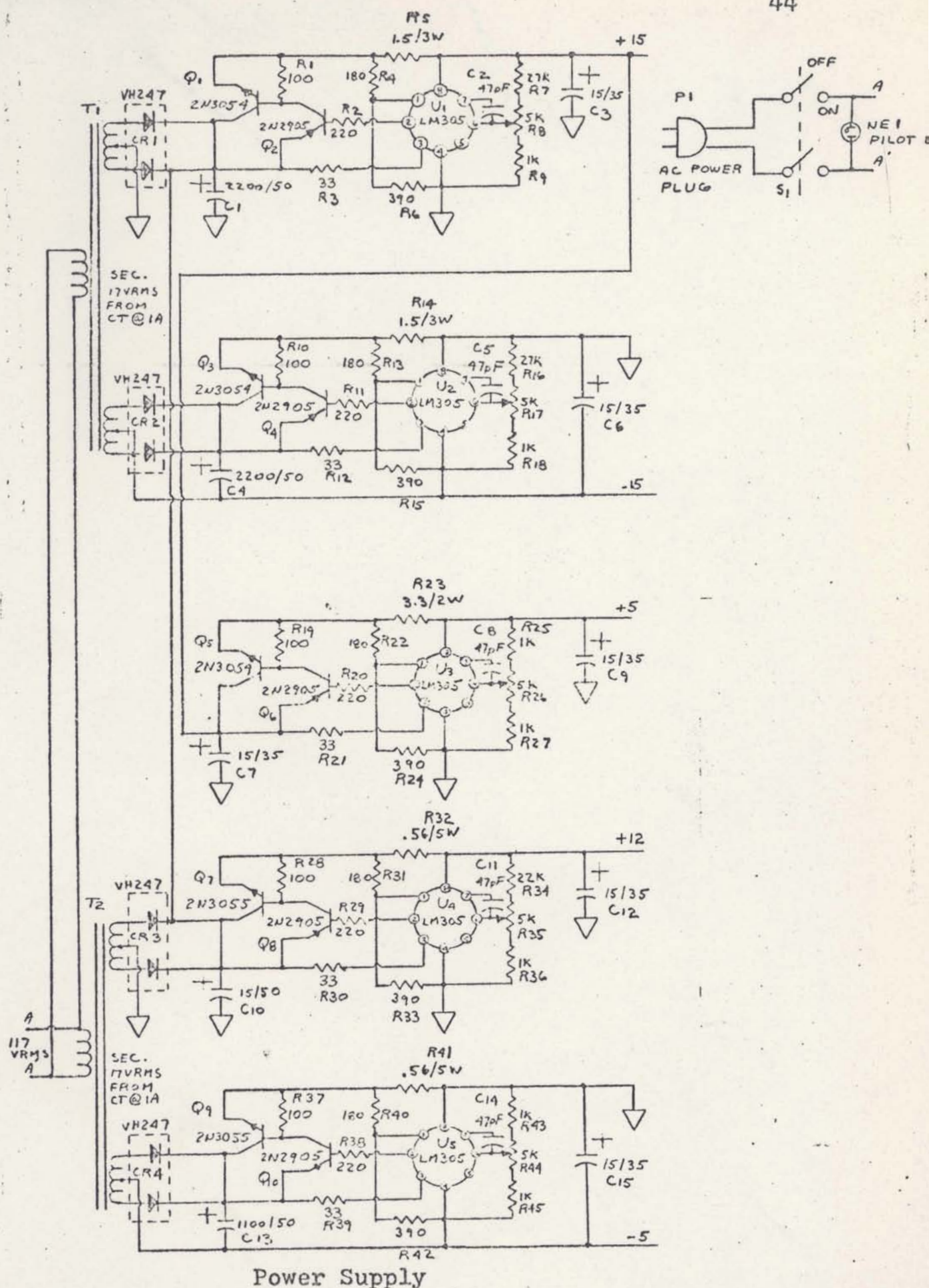

Power Supply

Figure 11

five system voltages (+15 volts, -15 volts, +5 volts, +12 volts, and -5 volts). The exact voltages are adjusted with trimmer potentiometers R8, R17, R26, and R44.

## 4.0 EXPERIMENTAL RESULTS

### 4.1 Introduction

The performance of the experimental SSB transmitter is evaluated in this chapter. The tests are divided into three groups called Single Tone Tests, Two-Tone Tests, and Voice Transmission Tests. The Single Tone Tests check the performance of certain individual circuits in the transmitter when a single frequency waveform is used as the test signal. The Two-Tone Tests check the system as a whole when two audio tones are applied to the microphone input of the Single Sideband Generator. The output signal, and signals at intermediate points in the circuit, are evaluated in these tests. Finally, the experimental system is tested for quality of the received audio in the Voice Transmission Tests.

### 4.2 Single Tone Tests

#### 4.2.1 Balanced Modulator Output

The output of the Balanced Modulator in the Single Sideband Generator was tested with an audio tone of 400 Hz. The test setup is shown in Figure 12 and the observed frequency spectrum is shown in Figure 13.

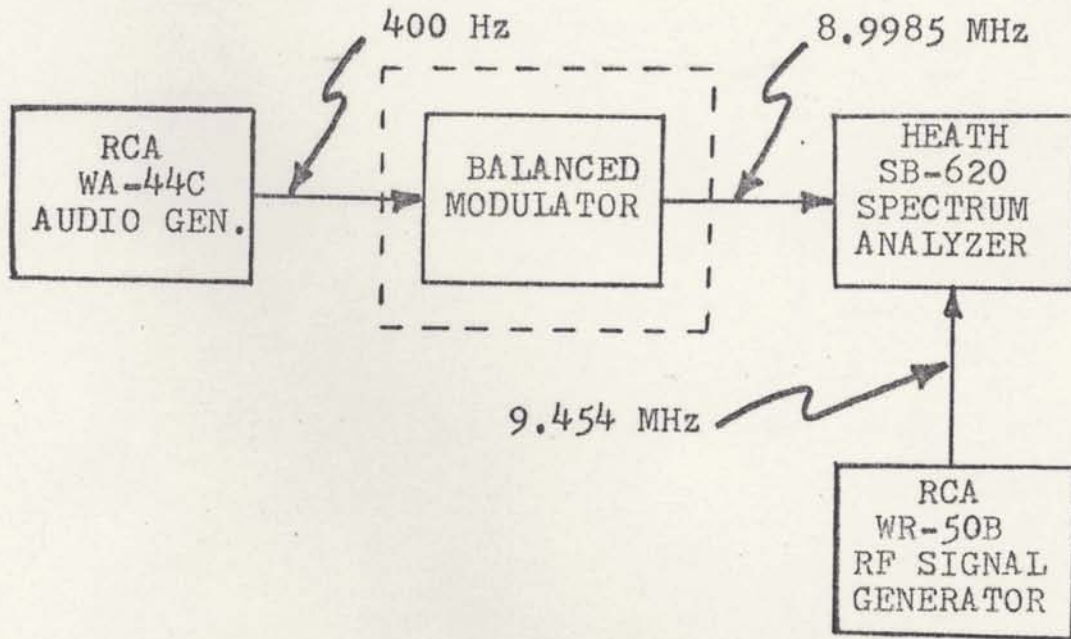

Balanced Modulator Output Test Setup

Figure 12

SCALE:

LOGARITHMIC

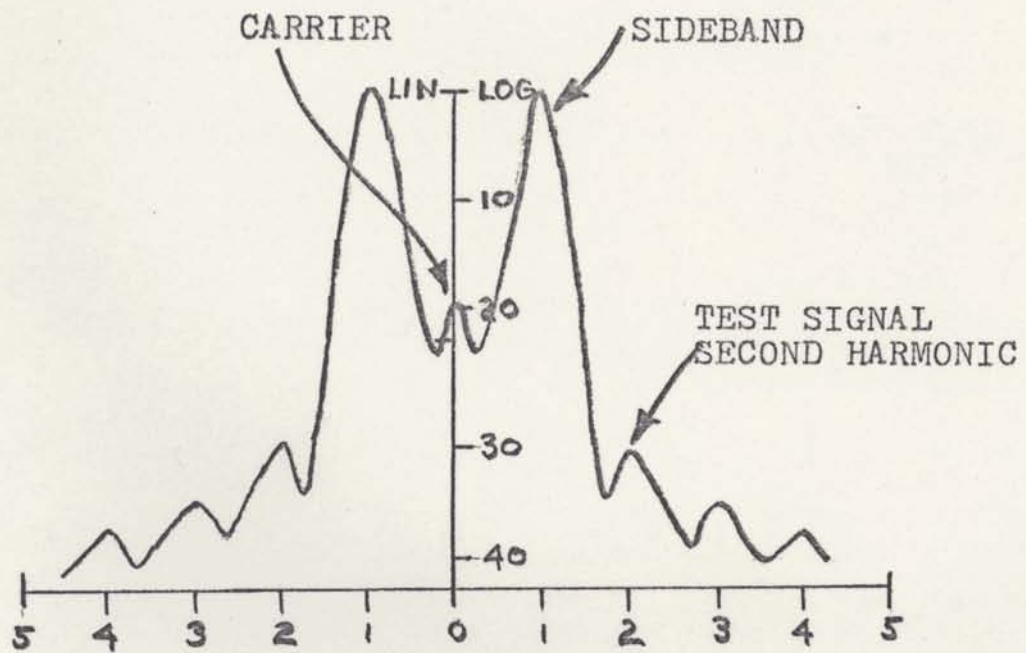

Frequency Spectrum of Balanced Modulator

Figure 13

The SB-620 Spectrum Analyzer used has an IF frequency of 455 kHz, and the WR-50B RF Generator serves as a local oscillator for heterodyning the 8.9985 MHz output of the Balanced Modulator to 455 kHz.

The carrier suppression of the Balanced Modulator was found to be 20 db. This is a poor level of carrier suppression, because 40 db of suppression can be obtained with careful design. Sidebands resulting from harmonics of the 400 Hz test tone were found to be 30 db down.

#### 4.2.2 Modulator Frequency Response

The frequency response of the Modulator was tested from DC to 200 kHz. The test setup is shown in Figure 14, and the normalized frequency response is shown in Figure 15.

The 3 db cutoff frequency is approximately 60 kHz. According to Kahn,<sup>1</sup> if the Modulator frequency response is flat for 6 kHz, and there is no phase shift within this bandwidth, spurious signals in the worst-case two-tone test will be suppressed better than 30 db below either of the

---

<sup>1</sup>Leonard R. Kahn, "Comparison of Linear Single Sideband Transmitters with Envelope Elimination and Restoration Single Sideband Transmitters," Proceedings of the I.R.E., December, 1956, pp. 1706-1712.



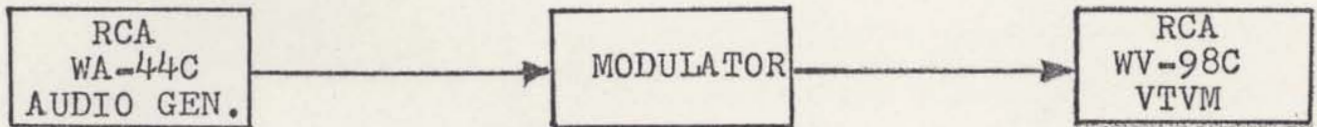

Frequency Response Test Setup

Figure 14

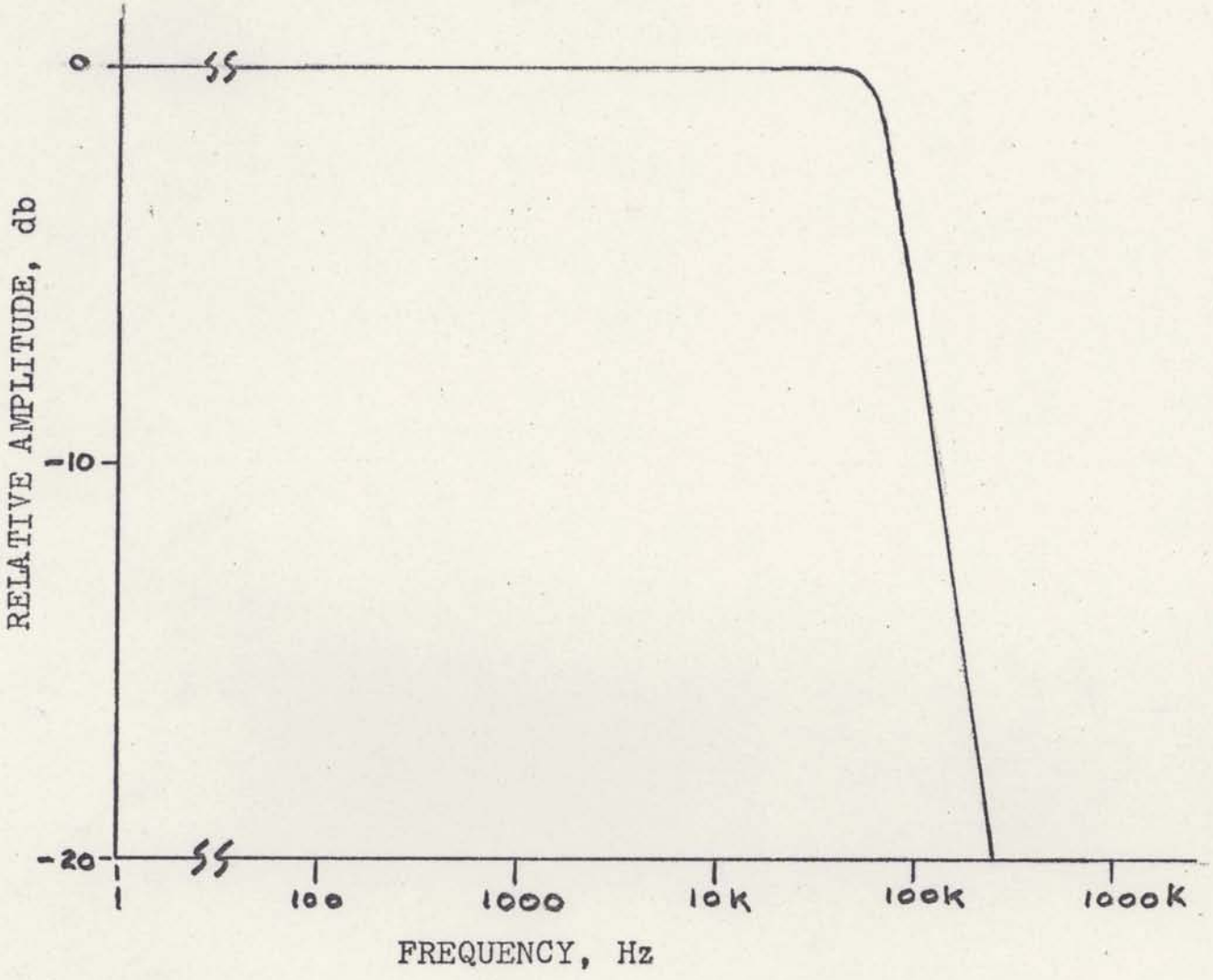

Modulator Frequency Response

Figure 15

desired tones. For a 3 db bandwidth of 60 kHz, the phase shift is only 5.7 degrees at 6 kHz.

#### 4.2.3 Transmitter AM Operation

The Transmitter was operated with a single 1000 Hz tone at the Modulator input to test its AM capability. The test setup is shown in Figure 16 and the monitored transmitter envelope is shown in Figure 17.

The maximum modulation percentage for an undistorted envelope was found to be 80 %.

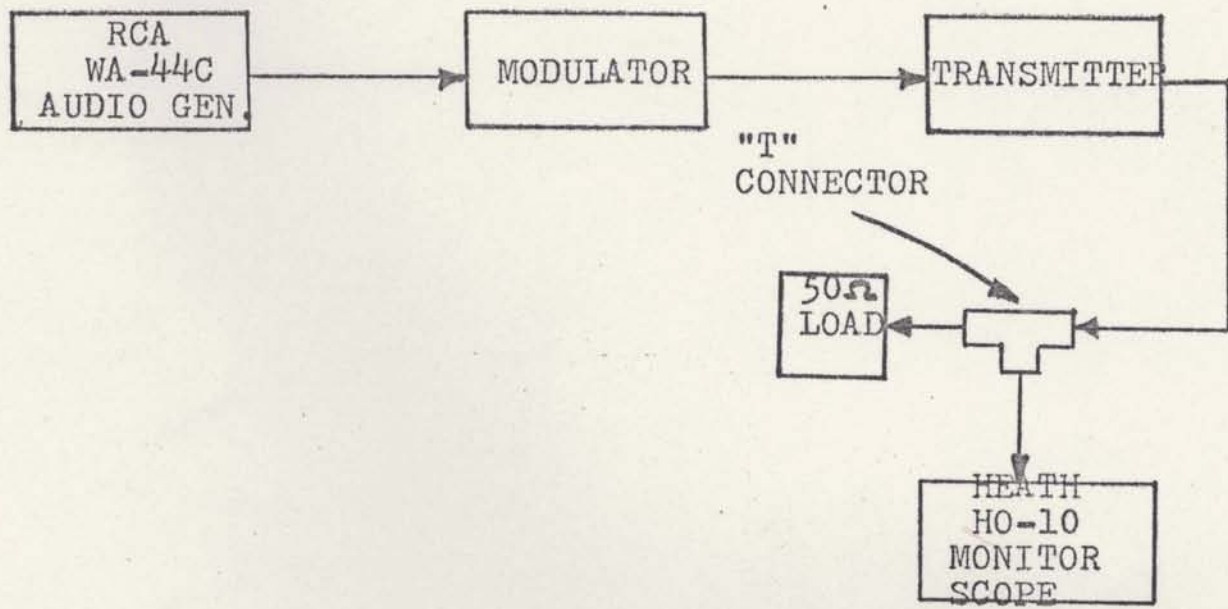

Transmitter AM Operation Test Setup

Figure 16

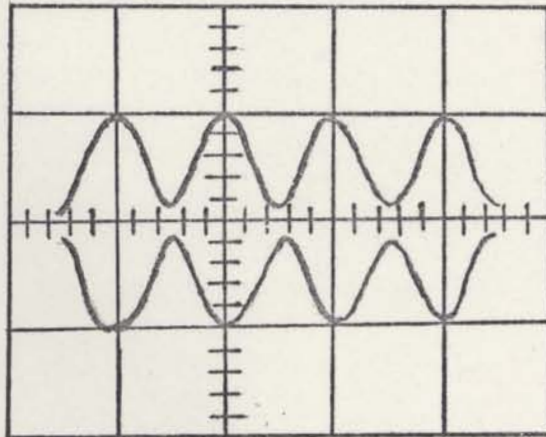

Transmitter Envelope for Single Tone Modulation

Figure 17

### 4.3 Two-Tone Tests

#### 4.3.1 SSB Generator Output

Two equal-amplitude tones of 980 Hz and 1800 Hz were applied to the SSB Generator. It was previously observed that the carrier is suppressed only 20 db at the Balanced Modulator output. For this reason, the carrier frequency was adjusted in this test so that it was attenuated 20 db further by the skirt of the crystal filter. For voice communication, the carrier frequency would have to be readjusted to avoid cutting off the lower voice frequencies.

Figure 18 shows the test setup, and Figure 19 shows the spectrum analyzer display.

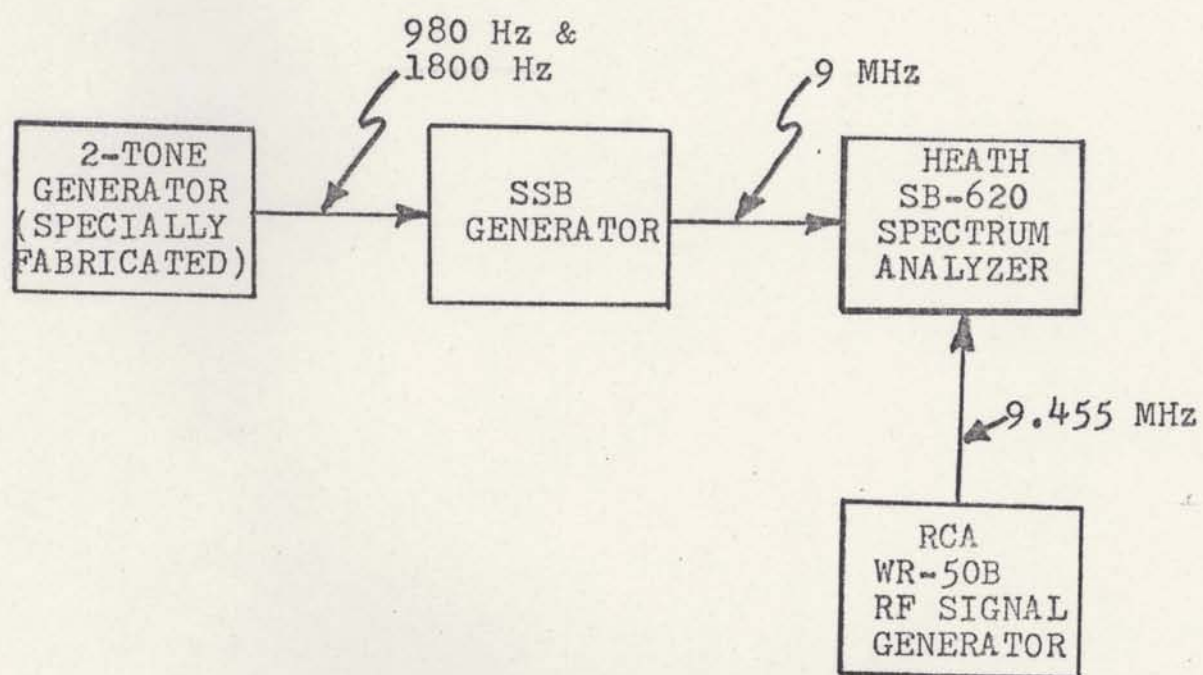

SSB Generator Output Test Setup

Figure 18

SCALE:

LOGARITHMIC

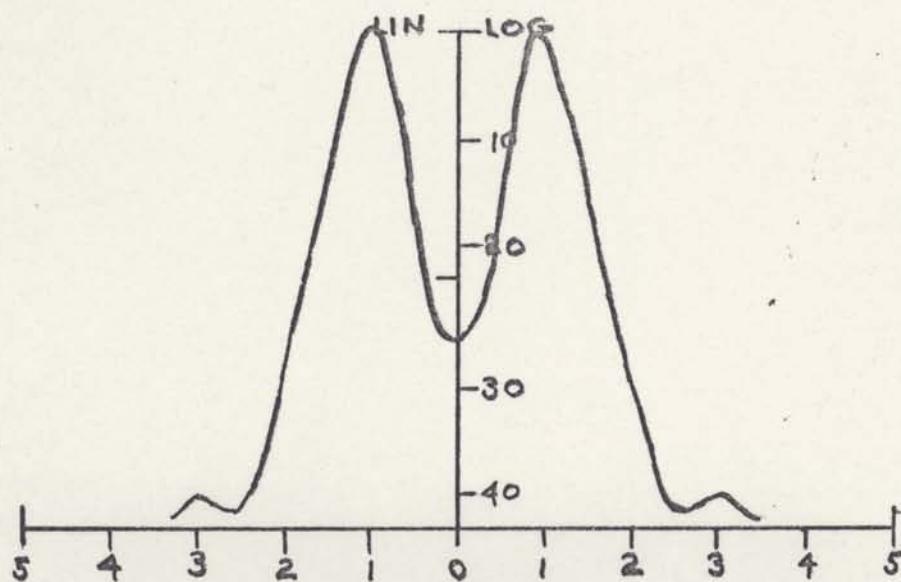

Frequency Spectrum of SSB Generator Output

Figure 19



### 4.3.2 Limiter Output

The output of the Limiter in the Signal Processor was displayed on a spectrum analyzer. The test setup is the same as the one in Figure 18, except that the spectrum analyzer is connected to the Limiter output. 980 Hz and 1800 Hz modulation is used, as before.

The observed frequency spectrum, shown in Figure 20, is the same as the one calculated in section 2 of Appendix A, and illustrated in Figure A6.

### 4.3.3 Frequency Divider Output

The Frequency Divider output of the Signal Processor was displayed on a spectrum analyzer. The test setup is similar to Figure 18, except that the spectrum analyzer is connected to the frequency divider output, and the RF signal generator output is set to 3.455 kHz.

The frequency spectrum of the Frequency Divider output is the same as that in Figure 20 (except, of course, for a difference in center frequency) which is the illustration for the frequency spectrum of the Limiter output. This is an interesting observation because the calculations made in section 3 of Appendix A indicate that the carrier term should

SCALE:

LINEAR

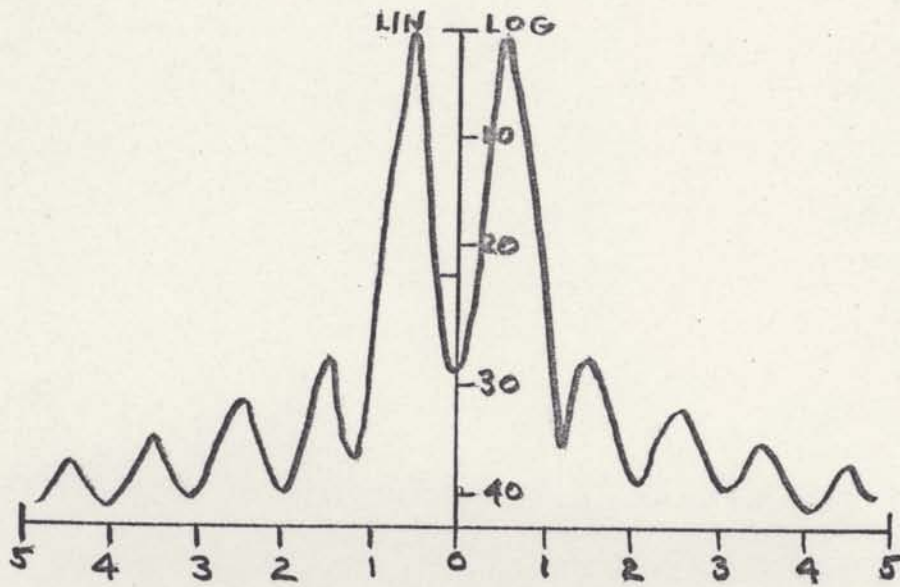

Frequency Spectrum of Limiter Output

Figure 20

be present at the center of the frequency spectrum. Paragraph 3.3 in Appendix A explains why the predicted carrier term does not appear at the output of the Frequency Divider. Except for the absent carrier, the frequency spectrum display is the same as that in Figure A6.

#### 4.3.4 Frequency Converter Output

The frequency spectrum of the Frequency Converter was displayed by using the test setup shown in Figure 21. The output of the Frequency Converter is applied to a doubly balanced mixer with a 117 MHz local oscillator. The mixer converts the 146 MHz output of the Frequency Converter to the sum and difference frequencies of 263 MHz and 29 MHz. The output of the mixer is applied to an amateur band communications receiver that is tuned to 29 MHz. The spectrum analyzer is connected to the second mixer output of the receiver, in which one of the output frequencies is 455 kHz. Because the spectrum analyzer used has an IF frequency of 455 kHz, no RF generator is required to center the display.

The spectrum analyzer display appears the same as that in Figure 20, except that noise is introduced into the display by the action of the mixer and the receiver.

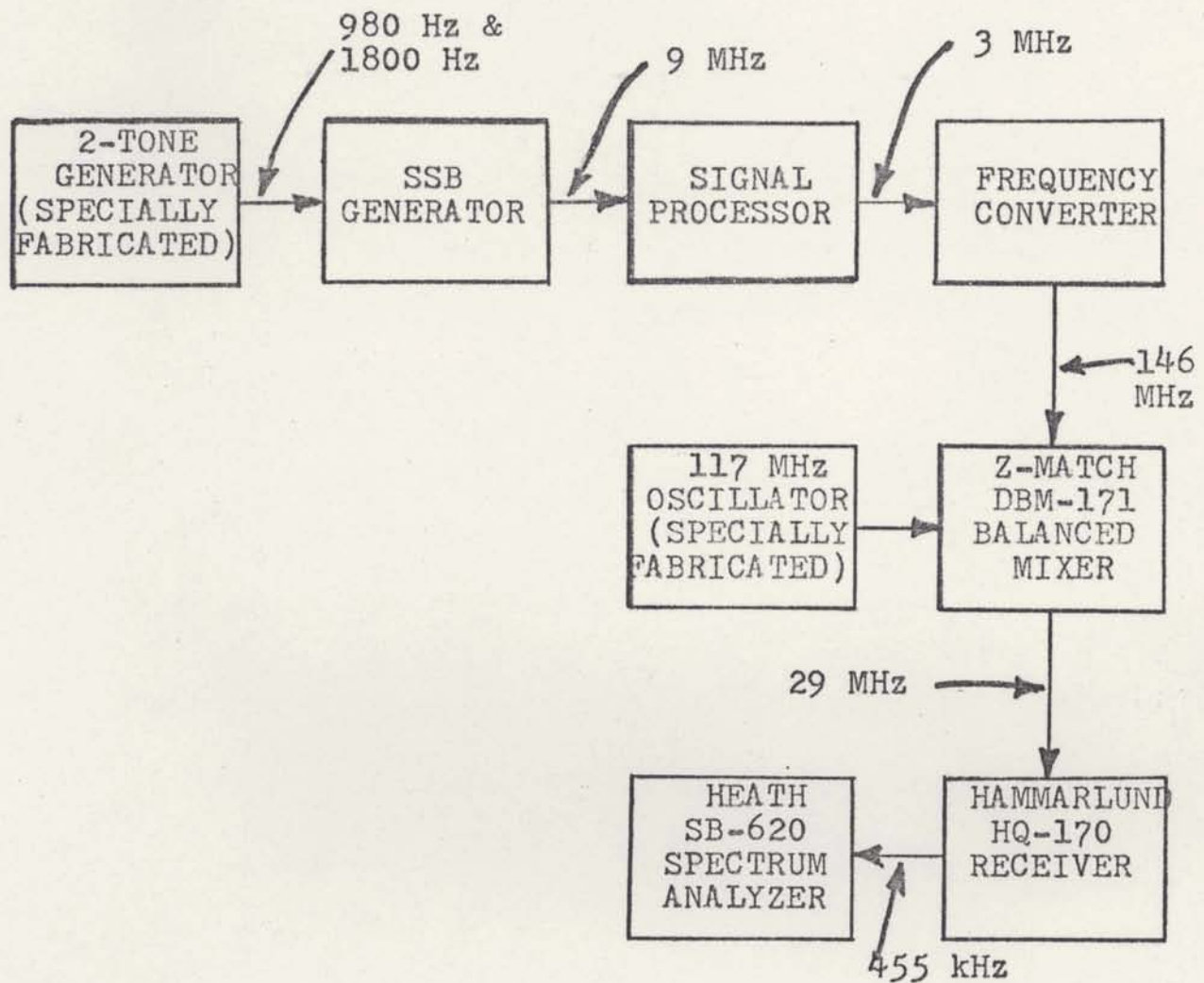

Frequency Converter Output Test Setup

Figure 21

### 4.3.5 Transmitter Output

The frequency spectrum of the complete SSB Transmitter was displayed on a spectrum analyzer. As in the previous tests, 980 Hz and 1800 Hz tones were used to modulate the signal. The test setup is similar to that in Figure 21. The Transmitter output was connected to a 50-ohm dummy load through a "T" connector. The common arm of the "T" connector was connected to the balanced mixer at the same point where the Frequency Converter output is applied to the mixer in Figure 21. Figure 22 shows the frequency spectrum of the transmitter output.

Figure 22 shows that the third-order distortion products are approximately 25 db below the level of a desired tone. The spectrum analyzer display appears somewhat noisy because of the noise in the mixer and receiver.

## 4.4 Voice Transmission Tests

### 4.4.1 Test Setup

The output of a tape recorder with a recorded voice tape was applied to the microphone input of the composite SSB Transmitter. The signal was heterodyned to 29 MHz by a mixer, as in Figure 21, and detected as an SSB signal by an

SCALE:

LOGARITHMIC

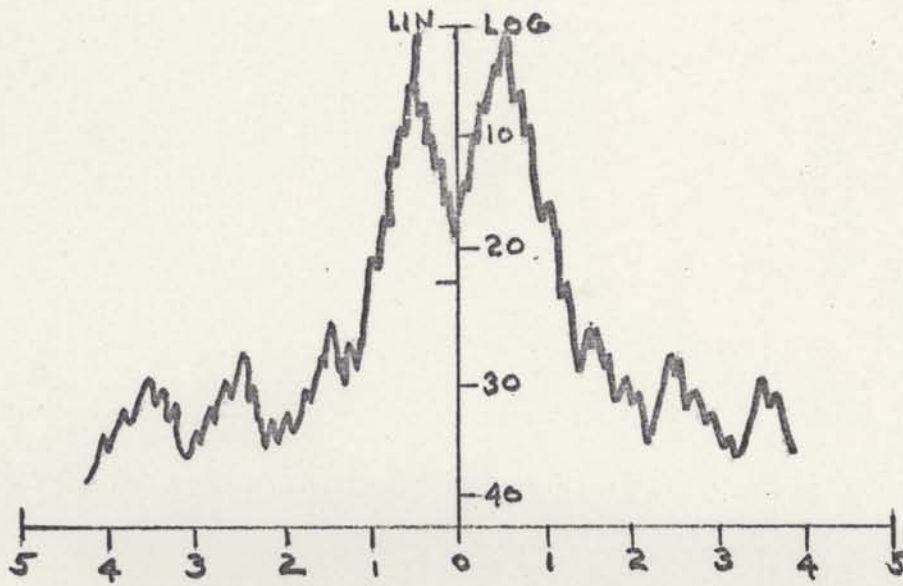

Frequency Spectrum of Transmitter Output

Figure 22

amateur band receiver. In the previous tests, the carrier oscillator in the Single Sideband Generator was adjusted to obtain additional carrier suppression. This was done to prevent the carrier from interfering with the data obtained in the two-tone tests. This, however, has the effect of cutting off lower frequency tones in the SSB output. The carrier oscillator had to be readjusted to allow the transmission of lower tones. This also increases the carrier level.

#### 4.4.2 Intelligibility

The transmitted signal was perfectly intelligible, but was masked by a high ambient noise level. Part of the noise is due to the action of the mixer and receiver, since noise is heard even if no signal is present. The Modulator also generates noise when the transmitter is developing RF power. This is due to insufficient shielding of the Modulator. Another source of noise is phase jitter in the frequency divider output of the Signal Processor. Increasing the RF gain of the Signal Processor increases the noise due to phase jitter, but it is necessary to maintain a high level of gain so that the total voice waveform is limited. This is because voice tends to have high peak power with respect to average power.

#### 4.4.3 Operating Without a Carrier

It was found that the experimental transmitter system had to develop a certain amount of carrier power to operate satisfactorily. This is because it is undesirable to cut off RF drive power to the transmitter during pauses in voice transmission. Complete suppression of the carrier (accomplished by detuning the carrier oscillator in the Single Sideband Generator) results in loud "snaps" being generated during the start of voice bursts, which is caused by transients resulting from the transmitter recovering from a cut-off state. These "snaps" are audible several kHz beyond the signal bandwidth. The need to generate a carrier should not present a problem, however, because a "pilot" carrier is generated, in any case, in commercial practice. It is only in amateur communications that a high degree of carrier suppression is commonly used.



## 5.0 CONCLUSIONS

### 5.1 Evaluation of Test Results

The test results indicate that it is feasible to construct a solid-state VHF SSB transmitter in the manner described in this paper, but certain improvements would have to be made in the experimental transmitter in order to obtain a successful commercial design. Specific areas where design improvements are in order are in reducing intermodulation distortion, and reducing noise in the Modulator and Signal Processor.

#### 5.1.1 Intermodulation Distortion

The third-order intermodulation products in a two-tone test were found to be 25 db below either test tone. This level meets the criterion established in paragraph 2.3.3 of this paper, where the acceptable third-order distortion level was calculated. However, it is apparent that the commonly accepted level of 30 db of third-order product suppression can be achieved by improved VHF AM transmitter design. The best downward modulation percentage that can be obtained with the design used is 80 %. This percentage can be improved by simply increasing the peak modulation voltage. The

absolute limit of downward modulation is the transistor collector saturation voltage, which may be above a volt at VHF frequencies. Increasing the modulation voltage makes the saturation voltage a smaller percentage of the RF voltage. The transistors used can safely accommodate twice the modulation voltage used by the experimental transmitter. This should should make a modulation percentage of 90 % possible.

The measured third-order distortion is approximately 6 db higher than could be accounted for by the limitation of the modulation percentage to 80 %. The remainder of the distortion may have been caused by envelope nonlinearity. Good envelope linearity can be maintained by ensuring that the modulated transistors have sufficient drive power throughout the modulation cycle. The drive power must not be excessive, however, because feed-through between the base and collector would tend to reduce the modulation percentage. Careful measurements would have to be made to establish acceptable design trade-offs.

It should be emphasized that the transmitter system described in this paper was designed, constructed, and tested in the author's home with his own equipment. The facilities for good circuit optimization were not available. The very low modulation voltage of 12 volts peak was used to avoid the destruction of RF power transistors, since very few were

available to the author. It is possible to design a far better AM transmitter in a commercial laboratory. Techniques already exist for constructing a VHF AM transmitter that is acceptable for use in an envelope elimination and restoration system.

### 5.1.2 Modulator Noise

Noise from the Modulator was apparent only when the Transmitter was developing RF power. This problem can be corrected with proper shielding. The experimental transmitter was built in a "breadboard" fashion, and is, therefore, susceptible to interference. As in any other transmitter, individual circuits should be built in separate enclosed metal compartments, with feed-through capacitors used in the power lines, and coaxial cables used in signal paths between circuits.

### 5.1.3 Signal Processor Noise

Noise from the Signal Processor is the major technical problem in the experimental system. The major difficulty is the fact that a very high-gain and low-noise amplifier must be used to obtain good speech clipping. The peak-to-average ratio of normal speech is approximately 14 db, and this means that a large dynamic range of speech must be handled by the

clipper. The clipper must have sufficient gain and limiting capability to "infinitely" clip the lower-level portions of the voice waveform, as well as the speech peaks.

Some phase jitter occurs as the result of error in frequency division. This effect has not been evaluated in this research, and it is not known if this can be a source of difficulty, but it can be eliminated by simply removing the Frequency Divider. The output of the limiter can then be heterodyned to the desired frequency in the conventional manner.

## 5.2 Practicality of the Design Approach

It was stated previously in this paper that the envelope elimination and restoration technique permits greater simplicity in the design and adjustment of RF power amplifiers than is possible with conventional SSB transmitters, but that it requires greater complexity in the design of lower-frequency circuits. A glance at the schematic diagrams in chapter 3 seems to dispute this statement, because there is no complexity apparent in these circuits. This is because the availability of low-cost integrated circuits has eliminated some of the difficulties in the design of envelope elimination and restoration systems. This fact is especially apparent in the circuit of the Modulator, which is a simple

chain of cascaded operational amplifiers. A direct-coupled wideband modulator, of the type used in the experimental system, would be practically impossible to build if vacuum-tube circuits were used. Paragraph 2.5 outlines the sort of approach that must be used if only vacuum tubes were available. A phase equalization network would be necessary, and separate AC and DC modulation paths would have to be used.

Another example of the value of integrated circuits is the simplicity of the Frequency Divider (Figure 7) design. Frequency division would not probably be even considered if vacuum tubes were used, because discrete frequency dividers are fairly complicated, and it would be easier to add additional heterodyning networks.

Some difficulties were experienced in the construction and testing of the experimental transmitter, but these problems can be eliminated by more careful attention to circuit design. No fundamental problems were found in the design approach, with the possible exception of the necessity for providing a pilot carrier. As it was pointed out earlier, a pilot carrier is actually desirable in a commercial SSB system.

APPENDIX AEFFECT OF FREQUENCY DIVISION OF THE PHASE MODULATION  
COMPONENT

## 1.0 Introduction

The ideal frequency spectrum at the output of the Frequency Divider is derived in this Appendix. Two-tone modulation is assumed.

First, the characteristics of the phase modulation component of a two-tone modulated SSB signal are deduced from the phasor diagram for the signal. Then, using a Fourier Series expansion, the frequency spectrum of the phase-modulation component is derived.

Next, the characteristics of the phase modulation component after frequency division by three, are deduced from the general principles governing the effect of frequency division upon the modulation index of a phase-modulated signal. Finally, the frequency spectrum after frequency division, is derived from the Fourier Series expansion.

## 2.0 Characteristics of the Phase Modulation Component

### 2.1 AM Phasor Diagram

Prior to analyzing the phasor diagram of an SSB signal, it is helpful to first look at the familiar phasor diagram for an AM signal. Figure A1 shows that the resultant of the carrier, upper sideband, and lower sideband phasors, is in phase with the carrier. Thus, if an AM signal were infinitely limited, only the carrier frequency would remain.

### 2.2 DSB-SC Phasor Diagram

The phasor diagram for a Double Sideband Suppressed Carrier signal is obtained by simply removing the carrier phasor from the AM phasor diagram. Figure A2 shows that the resultant of the upper sideband and lower sideband alternates between being in-phase and out of phase with the absent carrier. The phase-inversion occurs at the zero-crossing point of the envelope. Thus, if a DSB-SC signal were infinitely limited, a phase-shift keyed signal would remain. 180 degrees of the phase shift would occur where the envelope of the original signal crosses through zero.

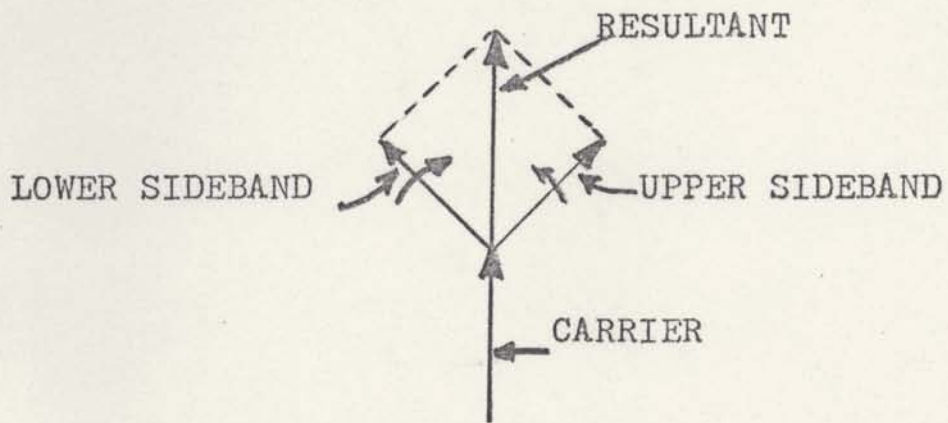

Phasor Representation of AM  
(Single Tone Modulation)

Figure A1

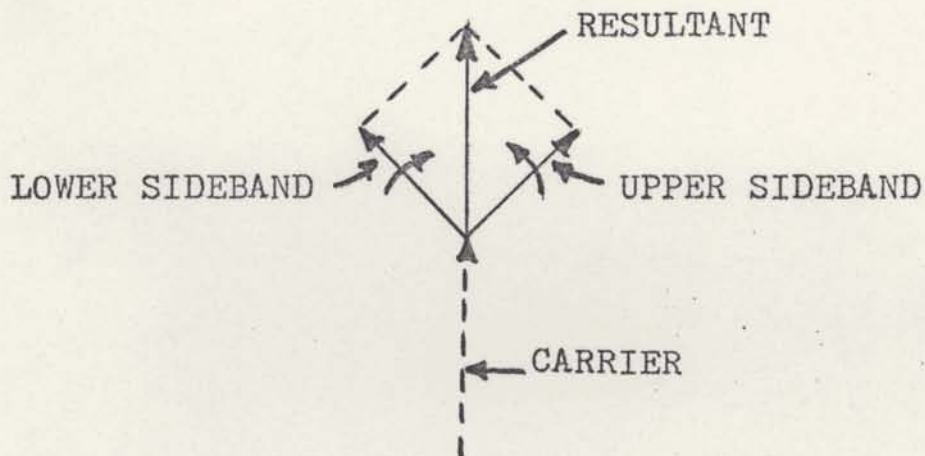

Phasor Representation of DSB-SC  
(Single-Tone Modulation)

Figure A2



### 2.3 SSB Phasor Diagram

It is well known that a two-tone modulated SSB signal is similar to a single-tone modulated DSB-SC signal. Since we have already determined the phase-modulation component of the DSB-SC signal, it is a simple matter to extend our reasoning to the SSB signal.

The difference between the DSB-SC and SSB signals is the position of the absent carrier. For DSB-SC, the carrier is between the two frequencies present, and for SSB, it is to one side. For the purpose of this analysis, let us suppose that there is an imaginary carrier between the two frequencies of the SSB signal with the phase relationship shown in Figure A3. To avoid any confusion that may result from the use of the word "imaginary", let us call this third frequency the Pseudo-Carrier. The Pseudo-Carrier is exactly the average of the two SSB frequencies. Note that the resultant in Figure A3 alternates between being in-phase and out of phase with the Pseudo-Carrier.

Again, the phase inversion occurs at the zero-crossing point of the envelope. Thus, an infinitely-limited SSB signal is a phase-shift keyed signal similar to that resulting from limiting a DSB-SC signal. The frequency of this phase-shift keyed signal is the Pseudo-Carrier, which we will call  $\omega_p$ .

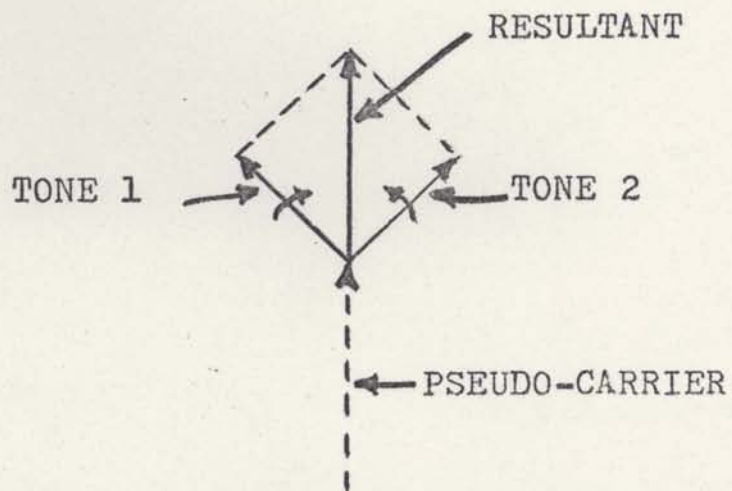

Phasor Representation of SSB and "Pseudo-Carrier"  
(Two-Tone Modulation)

Figure A3

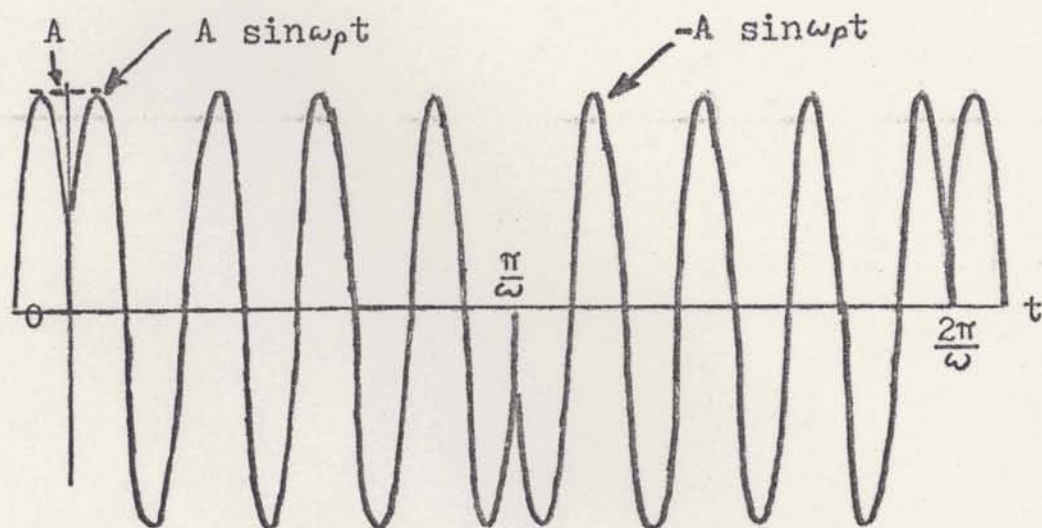

Phase Modulation Component of SSB  
(Two-Tone Modulation)

Figure A4

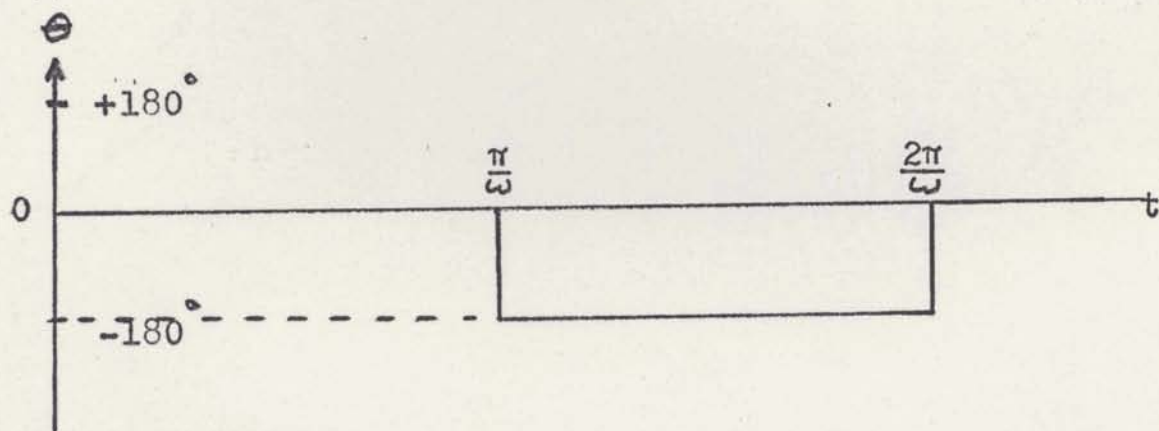

Phase Shift of SSB Phase Modulation Component  
(Two-Tone Modulation)

Figure A5

Phase-shift occurs at twice the frequency of the difference in frequency of the two SSB signals. We will call this rate of change  $\omega$ .

## 2.4 Fourier Series Analysis of the Phase Modulation Component

The phase modulation component in Figure A4 is an even function and therefore has only  $a_n$  components.

$$a_n = \frac{\omega}{\pi} \int_0^{2\pi/\omega} f(t) \cos n\omega t \, dt \quad (1)$$

Since,

$$f(t) = \begin{cases} A \sin \omega p t & 0 \leq t \leq \frac{\pi}{\omega} \\ -A \sin \omega p t & \frac{\pi}{\omega} \leq t \leq \frac{2\pi}{\omega} \end{cases} \quad (2)$$

$$\begin{aligned} a_n &= \frac{\omega}{\pi} \int_0^{\pi/\omega} A \sin \omega p t \cos n\omega t \, dt - \frac{\omega}{\pi} \int_{\pi/\omega}^{2\pi/\omega} A \sin \omega p t \cos n\omega t \, dt \\ &= \frac{\omega A}{2\pi} \int_0^{\pi/\omega} \sin (\omega p + n\omega) t \, dt + \frac{\omega A}{2\pi} \int_0^{\pi/\omega} \sin (\omega p - n\omega) t \, dt \end{aligned} \quad (3a)$$

$$\begin{aligned} &- \frac{\omega A}{2\pi} \int_{\pi/\omega}^{2\pi/\omega} \sin (\omega p + n\omega) t \, dt - \frac{\omega A}{2\pi} \int_{\pi/\omega}^{2\pi/\omega} \sin (\omega p - n\omega) t \, dt \\ &= \left. \frac{-\omega A \cos (\omega p + n\omega) t}{2\pi (\omega p + n\omega)} \right]_0^{\pi/\omega} - \left. \frac{-\omega A \cos (\omega p - n\omega) t}{2\pi (\omega p - n\omega)} \right]_0^{\pi/\omega} \\ &+ \left. \frac{\omega A \cos (\omega p + n\omega) t}{2\pi (\omega p + n\omega)} \right]_{\pi/\omega}^{2\pi/\omega} + \left. \frac{\omega A \cos (\omega p - n\omega) t}{2\pi (\omega p - n\omega)} \right]_{\pi/\omega}^{2\pi/\omega} \end{aligned} \quad (3b)$$

If  $\omega_p \gg \omega$ , and  $\omega_p \sim n\omega$ , the first and third terms of Equation 3b disappear. Thus,

$$a_n = -\frac{\omega A \cos(\omega_p - n\omega)t}{2\pi(\omega_p - n\omega)} \Bigg|_0^{\pi/\omega} + \frac{\omega A \cos(\omega_p - n\omega)t}{2\pi(\omega_p - n\omega)} \Bigg|_{\pi/\omega}^{2\pi/\omega} \quad (4a)$$

$$= -\frac{\omega A \cos(\omega_p \pi/\omega - n\pi)}{2\pi(\omega_p - n\omega)} + \frac{\omega A}{2\pi(\omega_p - n\omega)} \quad (4b)$$

$$+ \frac{\omega A \cos(2\omega_p \pi/\omega - 2n\pi)}{2\pi(\omega_p - n\omega)} - \frac{\omega A \cos(\omega_p \pi/\omega - n\pi)}{2\pi(\omega_p - n\omega)}$$

$$= \frac{\omega A}{2\pi(\omega_p - n\omega)} \left[ -2 \cos(\omega_p \pi/\omega - n\pi) \right] \quad (4c)$$

$$+ \cos(2\omega_p \pi/\omega - 2n\pi) + 1 \Big]$$

$$= \frac{A}{2\pi(\omega_p/\omega - n)} \left[ -2 \cos(\omega_p \pi/\omega - n\pi) \right] \quad (4d)$$

$$+ \cos(2\omega_p \pi/\omega - 2n\pi) + 1 \Big]$$

Assuming  $\omega_p/\omega$  is an even integer,

$$a_n = \frac{A}{2\pi(\omega_p/\omega - n)} (-2 \cos n\pi + \cos 2n\pi + 1) \quad (5a)$$

$$= \frac{A}{\pi(\omega_p/\omega - n)} (1 - \cos n\pi) \quad (5b)$$

If  $n = \omega_p/\omega + 1$ ,

$$a_n = \frac{A}{\pi} \frac{[1 - \cos(\omega_p/\omega + 1)\pi]}{(\omega_p/\omega - \omega_p/\omega - 1)} = -\frac{A(1 - \cos\pi)}{\pi} = -\frac{2A}{\pi} \quad (6a)$$

$$\text{If } n = \omega_p/\omega + 3, a_n = -2A/3\pi \quad (6b)$$

$$\text{If } n = \omega_p/\omega + 5, a_n = -2A/5\pi \quad (6c)$$

$$\text{If } n = \omega_p/\omega + 7, a_n = -2A/7\pi \quad (6d)$$

$$\text{If } n = \omega_p/\omega - 1, a_n = 2A/\pi \quad (6e)$$

$$\text{If } n = \omega_p/\omega - 3, a_n = 2A/3\pi \quad (6f)$$

$$\text{If } n = \omega_p/\omega - 5, a_n = 2A/5\pi \quad (6g)$$

$$\text{If } n = \omega_p/\omega - 7, a_n = 2A/7\pi \quad (6h)$$

The resulting frequency spectrum is shown in Figure A6.

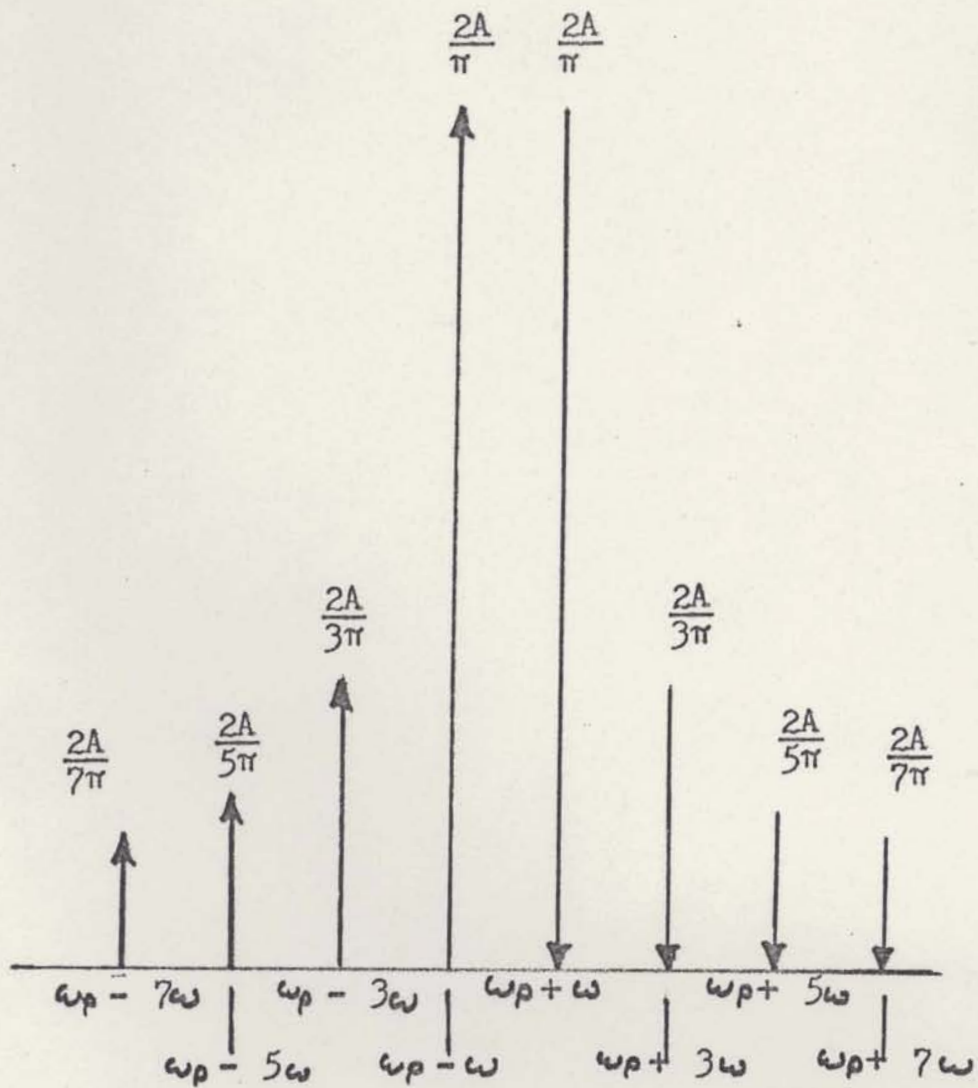

Frequency Spectrum of the Phase Modulation Component

Figure A6



## 2.5 Discussion of the Frequency Spectrum Analysis

The spacing of the components of the spectrum in Figure A6 is equal to the difference in frequency of the original SSB signals.

The same results were obtained by Kahn,<sup>1</sup> but he used an entirely different method of analysis. Kahn multiplied the two tones of the SSB signal with the inverse of the envelope function, and then found the Fourier Series expansion of the result. The advantage of the technique shown here is that it can be used to analyze the effect of frequency division (or multiplication) of the phase-modulation component, while this is not possible with the original technique.

---

<sup>1</sup>Ibid.

### 3.0 Analysis of the Effect of Frequency Division

#### 3.1 Change in Modulation Index

The equation for the phase modulation component is

$$f_{PM}(t) = A \sin [\omega_p t + \beta f(t)] \quad (1)$$

where  $f(t)$  is the phase modulation signal and  $\beta$  is the maximum phase shift, or the modulation index.

Frequency multiplication of a phase modulated signal results in both the carrier component and the modulation index being multiplied. Thus,

$$f'_{PM}(t) = A \sin [k\omega_p t + k\beta f(t)] \quad (2)$$

In the case of the system under consideration, the multiplication factor,  $k$ , is  $1/3$ . Thus,

$$f'_{PM}(t) = A \sin [\omega_p t/3 + \beta f(t)/3] \quad (3)$$

In section 2.3 of this Appendix, it was determined that  $\beta$  is 180 degrees, and  $f(t)$  is a square wave that is 0 for  $0 < t < \pi/\omega$ , and -1 for  $\pi/\omega < t < 2\pi/\omega$ . Thus,

$$f_{PM}^*(t) = \left. \begin{cases} A \sin \omega_p t / 3 & 0 \leq t \leq \pi / \omega, \text{ etc.} \\ A \sin \omega_p t / 3 - \pi / 3 & \pi / \omega \leq t \leq 2\pi / \omega, \text{ etc.} \end{cases} \right\} \quad (4)$$

### 3.2 Fourier Series Analysis of the Frequency Divider output

From the foregoing discussion, the waveform of the frequency divider output may be represented as the phase-shift-keyed signal shown in Figure A7, where  $\omega_d$  is the apparent carrier frequency of the divided output, and  $\omega_o$  is the total period.

The waveform in Figure A7 is neither odd nor even, and therefore must have both  $a_n$  and  $b_n$  components.

$$a_n = \frac{\omega_o}{\pi} \int_0^{2\pi/\omega_o} f(t) \cos n\omega_o t \, dt \quad (1)$$

$$b_n = \frac{\omega_o}{\pi} \int_0^{2\pi/\omega_o} f(t) \sin n\omega_o t \, dt \quad (2)$$

$$f(t) = \left. \begin{cases} A \sin \omega_d t & 0 \leq t \leq \pi / \omega_o \\ A \sin (\omega_d t - \pi / 3) & \pi / \omega_o \leq t \leq 2\pi / \omega_o \end{cases} \right\} \quad (3)$$

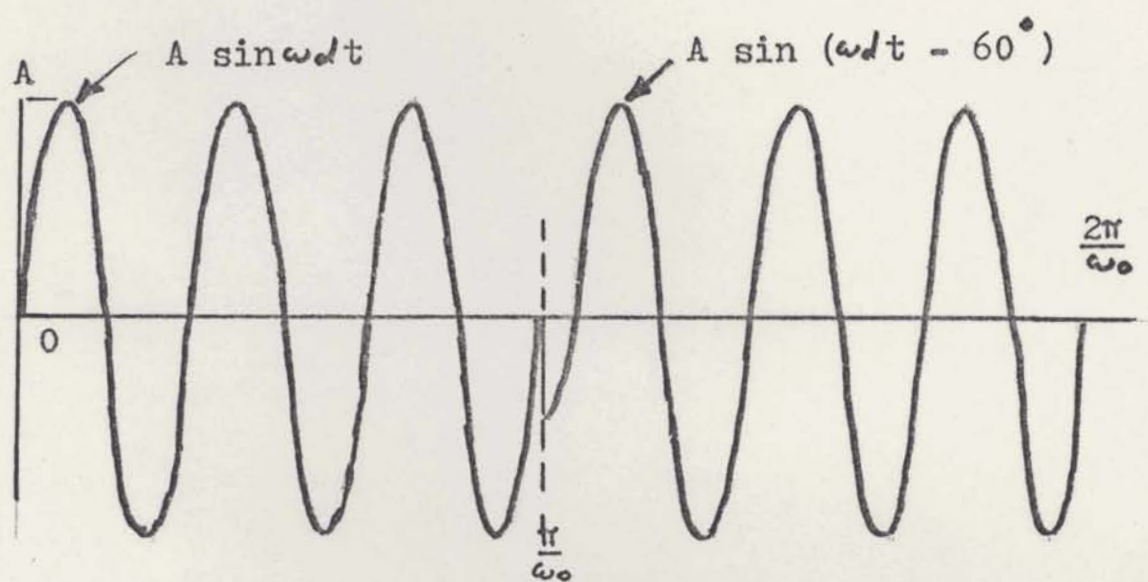

Waveform of the Frequency Divider Output

Figure A7

$$a_n = \frac{\omega_0}{\pi} \int_0^{\pi/\omega_0} A \sin \omega d t \cos n \omega_0 t dt \quad (4a)$$

$$+ \frac{\omega_0}{\pi} \int_{\pi/\omega_0}^{2\pi/\omega_0} A \sin (\omega d t - \pi/3) \cos n \omega_0 t dt$$

$$= \frac{\omega_0 A}{2\pi} \int_0^{\pi/\omega_0} \sin (\omega d + n \omega_0) t dt + \frac{\omega_0 A}{2\pi} \int_0^{\pi/\omega_0} \sin (\omega d - n \omega_0) t dt$$

$$+ \frac{\omega_0 A}{2\pi} \int_{\pi/\omega_0}^{2\pi/\omega_0} \sin [(\omega d + n \omega_0) t - \pi/3] dt \quad (4b)$$

$$+ \frac{\omega_0 A}{2\pi} \int_{\pi/\omega_0}^{2\pi/\omega_0} \sin [(\omega d - n \omega_0) t - \pi/3] dt$$

$$= - \frac{\omega_0 A \cos (\omega d + n \omega_0) t}{2\pi (\omega d + n \omega_0)} \Big|_0^{\pi/\omega_0} - \frac{\omega_0 A \cos (\omega d - n \omega_0) t}{2\pi (\omega d - n \omega_0)} \Big|_0^{\pi/\omega_0}$$

$$- \frac{\omega_0 A \cos [(\omega d + n \omega_0) t - \pi/3]}{2\pi (\omega d + n \omega_0)} \Big|_{\pi/\omega_0}^{2\pi/\omega_0} \quad (4c)$$

$$- \frac{\omega_0 A \cos [(\omega d - n \omega_0) t - \pi/3]}{2\pi (\omega d - n \omega_0)} \Big|_{\pi/\omega_0}^{2\pi/\omega_0}$$

If  $\omega d \gg \omega_0$ , and  $\omega d \sim n \omega_0$ , the first and third terms of Equation 4c disappear. Thus,

$$a_n = - \frac{\omega_0 A \cos (\omega d - n \omega_0) t}{2\pi (\omega d - n \omega_0)} \Big|_0^{\pi/\omega_0} \quad (5a)$$

$$- \frac{\omega_0 A \cos [(\omega d - n \omega_0) t - \pi/3]}{2\pi (\omega d - n \omega_0)} \Big|_{\pi/\omega_0}^{2\pi/\omega_0}$$

$$a_n = - \frac{A}{2\pi} \frac{[\cos(\pi \omega d / \omega_0 - n\pi) - 1]}{(\omega d / \omega_0 - n)}$$

$$- \frac{A \cos(2\pi \omega d / \omega_0 - 2n\pi - \pi/3)}{2\pi (\omega d / \omega_0 - n)} \quad (5b)$$

$$+ \frac{A \cos(\pi \omega d / \omega_0 - n\pi - \pi/3)}{2\pi (\omega d / \omega_0 - n)}$$

If  $\omega d / \omega_0$  is an integer,

$$a_n = - \frac{A}{2\pi} \frac{[\cos(\pi \omega d / \omega_0 - n\pi) - 1]}{(\omega d / \omega_0 - n)}$$

(6)

$$- \frac{A}{2\pi} \frac{[\cos(\pi/3) - \cos(\pi \omega d / \omega_0 - n\pi - \pi/3)]}{(\omega d / \omega_0 - n)}$$

If  $n = \omega d / \omega_0 + 1$ ,

$$a_n = - \frac{A}{2\pi} \frac{[\cos(\pi \omega d / \omega_0 - \pi \omega d / \omega_0 - \pi) - 1]}{(\omega d / \omega_0 - \omega d / \omega_0 - 1)}$$

$$- \frac{A}{2\pi} \frac{[1/2 - \cos(\pi \omega d / \omega_0 - \pi \omega d / \omega_0 - \pi - \pi/3)]}{(\omega d / \omega_0 - \omega d / \omega_0 - 1)} \quad (7a)$$

$$= - A/\pi + A/2\pi = - A/2\pi$$

$$\text{If } n = \omega d / \omega_0 + 3, a_n = - A/6\pi \quad (7b)$$

$$\text{If } n = \omega d / \omega_0 + 5, a_n = - A/10\pi \quad (7c)$$

$$\text{If } n = \omega/\omega_0 + 7, a_n = -A/14\pi \quad (7d)$$

$$\text{If } n = \omega/\omega_0 - 1, a_n = A/2\pi \quad (7e)$$

$$\text{If } n = \omega/\omega_0 - 3, a_n = A/6\pi \quad (7f)$$

$$\text{If } n = \omega/\omega_0 - 5, a_n = A/10\pi \quad (7g)$$

$$\text{If } n = \omega/\omega_0 - 7, a_n = A/14\pi \quad (7h)$$

$$b_n = \frac{\omega_0}{\pi} \int_0^{\pi/\omega_0} A \sin \omega d t \sin n \omega_0 t dt + \quad (8a)$$

$$\begin{aligned} & \frac{\omega_0}{\pi} \int_{\pi/\omega_0}^{2\pi/\omega_0} A \sin (\omega d t - \pi/3) \sin n \omega_0 t dt \\ &= -\frac{\omega_0 A}{2\pi} \int_0^{\pi/\omega_0} \cos (\omega d + n \omega_0) t dt + \frac{\omega_0 A}{2\pi} \int_0^{\pi/\omega_0} \cos (\omega d - n \omega_0) t dt \\ & -\frac{\omega_0 A}{2\pi} \int_{\pi/\omega_0}^{2\pi/\omega_0} \cos [(\omega d + n \omega_0) t - \pi/3] dt \\ & + \frac{\omega_0 A}{2\pi} \int_{\pi/\omega_0}^{2\pi/\omega_0} \cos [(\omega d - n \omega_0) t - \pi/3] dt \end{aligned} \quad (8b)$$

$$\begin{aligned}
b_n &= \left. \frac{-\omega_0 A \sin(\omega d + n\omega_0)t}{2\pi(\omega d + n\omega_0)} \right]_0^{\pi/\omega_0} + \left. \frac{\omega_0 A \sin(\omega d - n\omega_0)t}{2\pi(\omega d - n\omega_0)} \right]_0^{\pi/\omega_0} \\
&\quad - \left. \frac{\omega_0 A \sin[(\omega d + n\omega_0)t - \pi/3]}{2\pi(\omega d + n\omega_0)} \right]_{\pi/\omega_0}^{2\pi/\omega_0} \\
&\quad + \left. \frac{\omega_0 A \sin[(\omega d - n\omega_0)t - \pi/3]}{2\pi(\omega d - n\omega_0)} \right]_{\pi/\omega_0}^{2\pi/\omega_0}
\end{aligned} \tag{8c}$$

If  $\omega d \gg \omega_0$ , and  $\omega d \sim n\omega_0$ , the first and third terms of Equation 8c disappear. Thus,

$$\begin{aligned}
b_n &= \left. \frac{\omega_0 A \sin(\omega d - n\omega_0)t}{2\pi(\omega d - n\omega_0)} \right]_0^{\pi/\omega_0} \\
&\quad + \left. \frac{\omega_0 A \sin[(\omega d - n\omega_0)t - \pi/3]}{2\pi(\omega d - n\omega_0)} \right]_{\pi/\omega_0}^{2\pi/\omega_0}
\end{aligned} \tag{9a}$$

$$= \frac{\omega_0 A \sin(\pi \omega d / \omega_0 - n\pi)}{2\pi(\omega d - n\omega_0)}$$

$$+ \frac{\omega_0 A \sin(2\pi \omega d / \omega_0 - 2n\pi - \pi/3)}{2\pi(\omega d - n\omega_0)} \tag{9b}$$

$$- \frac{\omega_0 A \sin(\pi \omega d / \omega_0 - n\pi - \pi/3)}{2\pi(\omega d - n\omega_0)}$$

If  $\omega d / \omega_0$  is an integer,



$$b_n = \frac{A \sin (2\pi \omega d / \omega_0 - 2\pi n - \pi/3)}{2\pi (\omega d / \omega_0 - n)} \quad (10)$$

$$- \frac{A \sin (\pi \omega d / \omega_0 - \pi n - \pi/3)}{2\pi (\omega d / \omega_0 - n)}$$

If  $n = \omega d / \omega_0 + 1$ ,

$$b_n = \frac{A \sin (2\pi \omega d / \omega_0 - 2\pi \omega d / \omega_0 - 2\pi - \pi/3)}{2\pi (\omega d / \omega_0 - \omega d / \omega_0 - 1)} \quad (11a)$$

$$- \frac{A \sin (\pi \omega d / \omega_0 - \pi \omega d / \omega_0 - \pi - \pi/3)}{2\pi (\omega d / \omega_0 - \omega d / \omega_0 - 1)} = \frac{A\sqrt{3}}{2\pi}$$

$$\text{If } n = \omega d / \omega_0 + 3, b_n = \frac{A\sqrt{3}}{6\pi} \quad (11b)$$

$$\text{If } n = \omega d / \omega_0 + 5, b_n = \frac{A\sqrt{3}}{10\pi} \quad (11c)$$

$$\text{If } n = \omega d / \omega_0 + 7, b_n = \frac{A\sqrt{3}}{14\pi} \quad (11d)$$

$$\text{If } n = \omega d / \omega_0 - 1, b_n = - \frac{A\sqrt{3}}{2\pi} \quad (11e)$$

$$\text{If } n = \omega d / \omega_0 - 3, b_n = - \frac{A\sqrt{3}}{6\pi} \quad (11f)$$

$$\text{If } n = \omega d / \omega_0 - 5, b_n = - \frac{A\sqrt{3}}{10\pi} \quad (11g)$$

$$\text{If } n = \omega d / \omega_0 - 7, b_n = - \frac{A\sqrt{3}}{14\pi} \quad (11h)$$

The eight Fourier series terms for which the  $a_n$  and  $b_n$  factors have been calculated may be represented as follows:

$$\begin{aligned}
 f(t) = & \dots \frac{A \cos [(\omega_d - 7\omega_0)t - \pi/3]}{7\pi} \\
 & + \frac{A \cos [(\omega_d - 5\omega_0)t - \pi/3]}{5\pi} \\
 & + \frac{A \cos [(\omega_d - 3\omega_0)t - \pi/3]}{3\pi} \\
 & + \frac{A \cos [(\omega_d - \omega_0)t - \pi/3]}{\pi} + (\text{carrier term}) \quad (12) \\
 & - \frac{A \cos [(\omega_d + \omega_0)t - \pi/3]}{\pi} \\
 & - \frac{A \cos [(\omega_d + 3\omega_0)t - \pi/3]}{3\pi} \\
 & - \frac{A \cos [(\omega_d + 5\omega_0)t - \pi/3]}{5\pi} \\
 & - \frac{A \cos [(\omega_d + 7\omega_0)t - \pi/3]}{7\pi} \dots
 \end{aligned}$$

Since all of the terms of Equation 12 have half the level of those of Figure A6, they must contain 1/4 of the total power of the frequency spectrum. The remainder of the power is contained in the carrier.

The total power is  $KA^2$ , and 3/4 of the power is  $\frac{3}{4}KA^2$ , or  $K(\frac{\sqrt{3}}{2}A)^2$ . Therefore, the amplitude of the carrier is  $\frac{\sqrt{3}}{2}A$ .

An absolute-value spectrum diagram of the frequency divider output is shown in Figure A8.

### 3.3 Comparison of Calculated Frequency Divider Output with Spectrum Analyzer Measurements

Spectrum analyzer tests indicate that the frequency divider output has sidebands with the same relative ratio calculated in the previous section, but that no carrier is present. This is because a physical frequency divider does not produce a waveform as shown in Figure A7 when a 180 degree phase-shift keyed signal is applied to it. The modulating signal of the actual waveform shifts the phase of the divided signal first by -60 degrees, then -120 degrees, then -180 degrees, etc. The discrepancy results from the ambiguity in the phase shift of the phase modulation component of the SSB signal. Figure A5 shows only one of the possible ways of representing the phase shift, because it is impossible to determine if 180 degrees of phase rotation is in the positive or negative direction.

The absence of carrier power in the actual frequency divider output indicates that there has not been a true change in modulation index as the result of frequency division. Since all of the power of both the input and output signals are in the sidebands, and the sidebands have

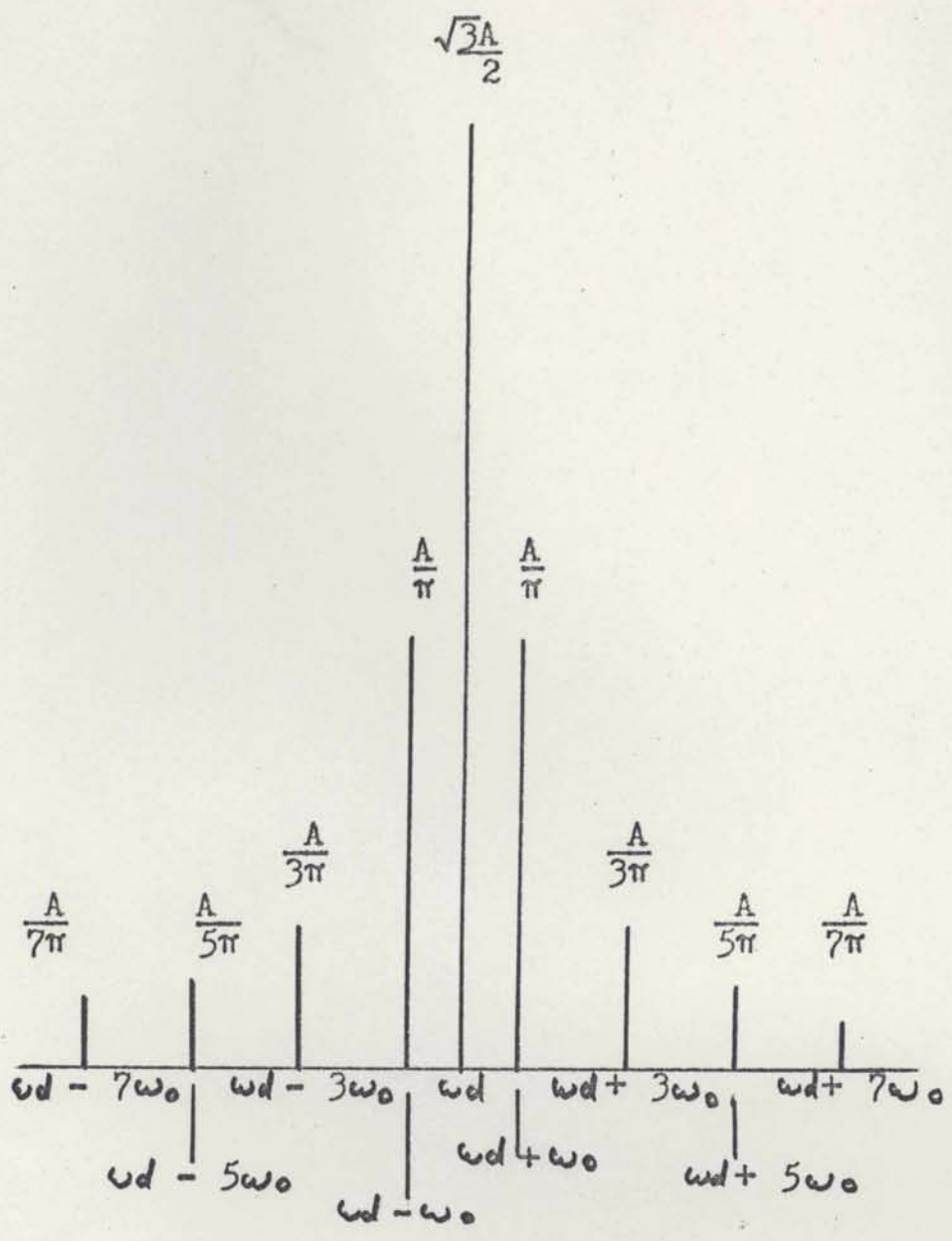

Frequency Spectrum of Frequency Divider Output

Figure A8

the same relative ratios in both signals, the two signals are modulated to the same degree. The frequency divider has more phase rotation in the phase-shift keyed bursts than was originally expected, because, while the individual bursts differ by each other by only 60 degrees, there is a phase difference of 300 degrees between the first and last bursts in a modulation cycle.

The foregoing is an interesting exception to the general rule that frequency division results in division of the modulation index of a phase modulated signal.

APPENDIX BTHE EFFECT OF PHASE SHIFT IN THE ENVELOPE ELIMINATION  
AND RESTORATION SYSTEM

This Appendix shows the relative effect of phase shift in the RF and AF paths of an envelope elimination and restoration system.

Figure A6 shows the frequency spectrum of the phase modulation component of two equal SSB tones. In order to suppress all of the distortion products of Figure A6, it is necessary to multiply the phase modulation component by the envelope component. This is done by multiplying each term of the Fourier series of the envelope component with each term of the Fourier series of the phase modulation component. As an illustrative example, let us multiply a few terms of the phase modulation component with the DC and first harmonic terms of the envelope component.

The following phase modulation terms will be used in the analysis:

$$f_{PM}(t) = \frac{\cos(\omega_p - 7\omega)t}{7} + \frac{\cos(\omega_p - 5\omega)t}{5} + \frac{\cos(\omega_p - 3\omega)t}{3}$$

$$+ \cos(\omega_p - \omega)t - \cos(\omega_p + \omega)t - \frac{\cos(\omega_p + 3\omega)t}{3}$$

$$- \frac{\cos(\omega_p + 5\omega)t}{5} - \frac{\cos(\omega_p + 7\omega)t}{7} \quad (1)$$

The envelope component of an SSB signal with two equal tones is a full-wave rectified sine wave. The DC and first harmonic terms are:

$$E(t) = 1 - \frac{2 \cos 2\omega t}{3} \quad (2)$$

Multiplying the two components gives the following:

$$\begin{aligned} E(t) f_{PM}(t) &= \frac{\cos(\omega_p - 7\omega)t}{7} + \frac{\cos(\omega_p - 5\omega)t}{5} \\ &+ \frac{\cos(\omega_p - 3\omega)t}{3} + \cos(\omega_p - \omega)t - \cos(\omega_p + \omega)t \\ &- \frac{\cos(\omega_p + 3\omega)t}{3} - \frac{\cos(\omega_p + 5\omega)t}{5} - \frac{\cos(\omega_p + 7\omega)t}{7} \\ &- \frac{\cos(\omega_p - 5\omega)t}{21} - \frac{\cos(\omega_p - 9\omega)t}{21} - \frac{\cos(\omega_p - 3\omega)t}{15} \\ &- \frac{\cos(\omega_p - 7\omega)t}{15} - \frac{\cos(\omega_p - 5\omega)t}{9} - \frac{\cos(\omega_p - \omega)t}{9} \\ &- \frac{\cos(\omega_p - 3\omega)t}{3} - \frac{\cos(\omega_p + \omega)t}{3} + \frac{\cos(\omega_p - \omega)t}{3} \\ &+ \frac{\cos(\omega_p + 3\omega)t}{3} + \frac{\cos(\omega_p + \omega)t}{9} + \frac{\cos(\omega_p + 5\omega)t}{9} \end{aligned}$$

$$\begin{aligned}
& + \frac{\cos(\omega_p + 7\omega)t}{15} + \frac{\cos(\omega_p + 3\omega)t}{15} + \frac{\cos(\omega_p + 9\omega)t}{21} \\
& + \frac{\cos(\omega_p + 5\omega)t}{21}
\end{aligned} \tag{3}$$

$$E(t) f_{PM}(t) = .03916 \cos(\omega_p - 7\omega)t$$

$$+ .04127 \cos(\omega_p - 5\omega)t - .0667 \cos(\omega_p - 3\omega)t$$

Signal Terms

$$+ 1.222 \cos(\omega_p - \omega)t - 1.222 \cos(\omega_p + \omega)t \tag{4}$$

$$+ .0667 \cos(\omega_p + 3\omega)t - .04127 \cos(\omega_p + 5\omega)t$$

$$- .03916 \cos(\omega_p + 7\omega)t$$

Equations 3 and 4 are illustrated graphically in Figure B1. Note that the signal terms are at least 25.3 db above any of the spurious frequency terms.

If there is a phase shift in the phase modulation component, all of the spectral components will be shifted equally because the carrier frequency is assumed to be high compared with the frequency spacing between spectral components. This would result in equal phase shift in all of the terms in Equation 3, and there would be no difference in the relative amplitudes of the signal terms and the spur-



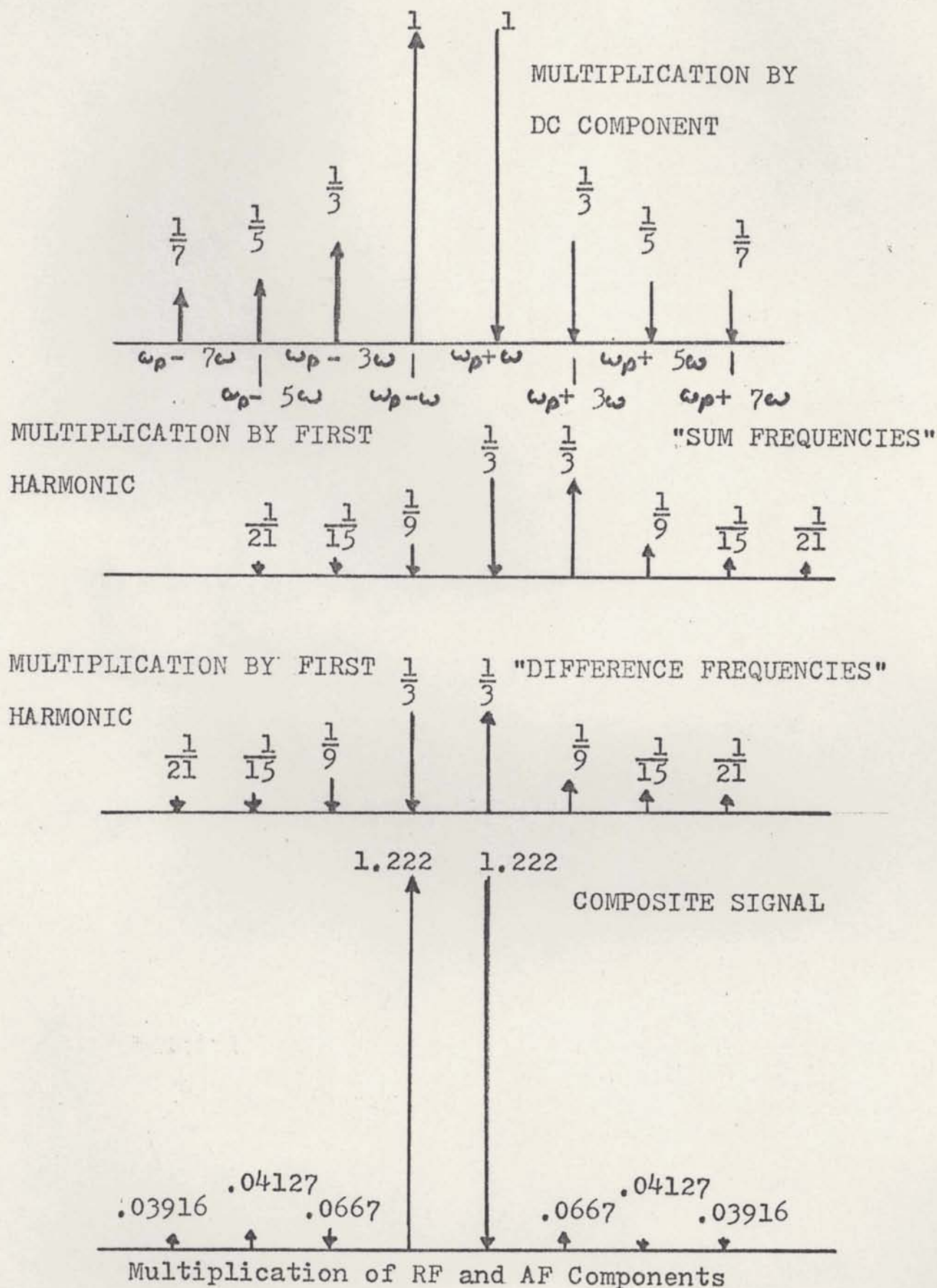

Figure B1

ious frequency terms. If there is a phase shift in the envelope function, however, all of the terms in Equation 3 would not have an equal phase shift, and there would be less cancellation of the spurious frequency components.

APPENDIX C

## LINEAR AMPLIFICATION WITH CLASS C AMPLIFIERS

Figure C1<sup>1</sup> shows a method of RF linear amplification that is currently being used for developing AM power in the 225 to 400 MHz military aircraft band. The RF amplifier is of the class C type, and it is operated in a feedback system that improves the linearity of the output. The feedback system appears very much like a voltage follower operational amplifier, where the input signal is applied to the non-inverting input, and the output is connected directly to the inverting input. If the system has sufficient gain, the signals at the inverting and non-inverting inputs are the same.

The modulation signal is applied to the non-inverting input of a Differential Amplifier, and the detected envelope of the RF Amplifier output is applied to the inverting input. The bias signal at the non-inverting input corresponds to the carrier component of the detected envelope. The Differential Amplifier controls the instantaneous gain of a Variable Attenuator that modulates the output of the AM source.

---

<sup>1</sup>Gilson, op. cit., p. 7.

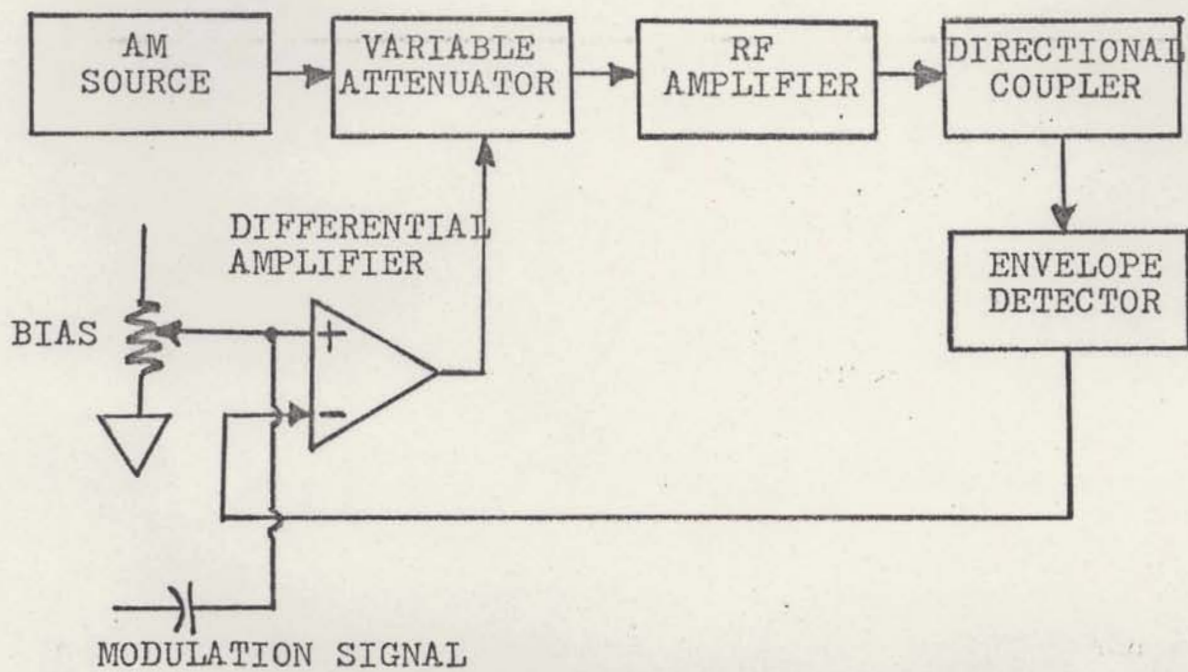

Class C Linear Amplifier

Figure C1

The Variable Attenuator applies sufficient distortion to the AM Source signal to correct for nonlinearities in the class C Amplifier. In practice, a transistorized class C amplifier has very low gain at low input power levels. The gain increases after the input threshold level of the amplifier is exceeded, but decreases at high input power levels.

In order to obtain linear operation of the RF Amplifier, the Variable Attenuator must pass sufficient power from the AM Source to exceed the threshold level of the amplifier. Thus, the AM Source cannot be 100 % modulated at the negative peaks, because this would result in over modulation of the RF Amplifier output. The maximum allowable percentage of modulation depends upon the amplitude of the AM Source, and the dynamic range of the Variable Attenuator. A modulation percentage of 85 % has been achieved in practice, with an envelope distortion of less than 5 %. This modulation percentage and envelope linearity are insufficient for good SSB operation. The SSB envelope has 100 % downward modulation, and 5 % envelope distortion corresponds to third-order products being only 16 db down in a two-tone test.

If the system described here is used to amplify SSB signals, the modulation signal may be obtained from the output of

an envelope detector connected to the low-level SSB source.

## BIBLIOGRAPHY

Gilson, Russell A. "A Simple High-Performance Feedback Modulation System." Research and Development Technical Report ECOM-3224, Fort Monmouth, N.J.: United States Army Electronics Command, January, 1970.

Kahn, Leonard R. "Comparison of Linear Single Sideband Transmitters with Envelope Elimination and Restoration Single Sideband Transmitters." Proceedings of the I.R.E., December, 1956, pp. 1706-1712.

Kahn, Leonard R. "Single Sideband Transmission by Envelope Elimination and Restoration." Proceedings of the I.R.E., July, 1952, pp. 803-806.

Meinzer, Karl. "A Frequency Multiplication Technique for VHF and UHF SSB." QST, October, 1970, pp. 32-35.

RCA RF Power Transistor Manual. Sommerville, N.J.: RCA Solid State Division, 1971, pp. 12-16 and 68-84.

U.S. Federal Communications Commission. "Aviation Services." Rules and Regulations, Washington, D.C.: Government Printing Office, January, 1970.

U.S. Federal Communications Commission. "Frequency Allocations and Radio Treaty Matters; General Rules and Regulations." Rules and Regulations, Washington, D.C.: Government Printing Office, September, 1972.

Villard, O.G. "Composite Amplitude and Phase Modulation." Electronics, November, 1948, pp. 86-89.