Retrospective Theses and Dissertations

Fall 1982

Simulation of Traffic at a T-Intersection Using Slam

Karen M. Anderson
University of Central Florida



Part of the [Engineering Commons](#)

Find similar works at: <https://stars.library.ucf.edu/rtd>

University of Central Florida Libraries <http://library.ucf.edu>

This Masters Thesis (Open Access) is brought to you for free and open access by STARS. It has been accepted for inclusion in Retrospective Theses and Dissertations by an authorized administrator of STARS. For more information, please contact STARS@ucf.edu.

STARS Citation

Anderson, Karen M., "Simulation of Traffic at a T-Intersection Using Slam" (1982). *Retrospective Theses and Dissertations*. 609.

<https://stars.library.ucf.edu/rtd/609>

SIMULATION OF TRAFFIC
AT A T-INTERSECTION
USING SLAM

BY

KAREN M. ANDERSON
B.A., University of Florida, 1972

RESEARCH REPORT

Submitted in partial fulfillment of the requirements
for the degree of Master of Science
in the Graduate Studies Program of the College of Engineering
University of Central Florida
Orlando, Florida

Fall Term
1982

ABSTRACT

The flow of traffic at an intersection is often controlled by a traffic signal. This research report models a T-intersection with a disjoint network for each direction of traffic flow, eastbound, westbound and southbound. The traffic signal is modeled with a fourth network. Three types of signal control (pretimed, semi-actuated and full-actuated) are modeled to examine the effect of each type on the average delay time and average length of queues for each lane of traffic queue at the intersection.

The computer models presented in this report use SLAM computer language to simulate the traffic signal and vehicle flow.

TABLE OF CONTENTS

LIST OF FIGURES	iv
Chapter	
I. INTRODUCTION	1
Traffic Control Problems	1
Why Signalize	2
Why Simulate	3
SLAM	5
II. MODEL	6
Project Description	6
Inter-arrival Rates	8
Assumptions	9
Traffic Networks	10
Traffic Signals	19
III. CONCLUSION	32
Verification	32
Analysis of Results	39
Areas for Further Research	46
APPENDIX A: Table of SLAM Notations	50
APPENDIX B: Conversion Table	51
APPENDIX C: Program Listing for Traffic Networks	52
APPENDIX D: Program Listing for Traffic Signals	54
REFERENCES CITED	58
BIBLIOGRAPHY	59

LIST OF FIGURES

1. Zones of the Howell Branch Road-State Road 426 Intersection . 11

2. Westbound Traffic. 13

3. Eastbound Traffic. 16

4. Southbound Traffic 18

5. Pretimed/No Left Turn Arrow. 20

6. Pretimed/Exclusive Left Turn Arrow 21

7. Pretimed/Exclusive-permissive Left Turn Arrow. 22

8. Semi-actuated/No Left Turn Arrow 24

9. Semi-actuated/Exclusive Left Turn Arrow. 25

10. Semi-actuated/Exclusive-permissive Left Turn Arrow 26

11. Full-actuated/No Left Turn Arrow 28

12. Full-actuated/Exclusive Left Turn Arrow. 29

13. Full-actuated/Exclusive-permissive Left Turn Arrow 30

14-19. Time Lapse of a Deterministic Simulation Run 33

20. Verification for Southbound Left-turning Traffic 40

21. Verification for Eastbound Left-turning Traffic 41

22. Summary of Results for Pretimed Signal 43

23. Summary of Results for Semi-actuated Signal 44

24. Summary of Results for Full-actuated Signal 45

CHAPTER I
INTRODUCTION

Traffic Control Problems

The Department of Transportation continuously has the decision of whether to install a traffic signal at a particular intersection, change the type of signal, or maintain the current traffic control.

Installation of a traffic signal doesn't automatically solve the problems at the intersection. In some cases, it may create accidents or traffic delays. Therefore, the Department of Transportation installs a signal only when it meets certain minimum warrants published in the Manual on Uniform Traffic Control Devices. After the signal is installed, it must be operated properly in order to maintain optimal traffic flow conditions.

The best controller system will not alleviate intersection congestion if the demand consistently exceeds the capacity, causing long queues. Likewise, good hardware will not improve bad operation if the signal timing is poor, causing long delays.

After data has been collected for the intersection and after the installation has been authorized, a number of variables must be noted in order to optimize the traffic performance.

The timing plan must be considered. This is based on whether the intersection is of the isolated type or the arterial and network type. Since timing must be responsive to traffic demands, the cycle length

and phase length must be adjusted to match the intersection capacity to its demand. The offset, or interval of time between the beginning of green at one signal and the beginning of green at the next signal, must be adjusted to match the predominant movement of traffic.

Geometric factors must be noted, e.g., the number of lanes, whether the number increases or decreases, the intersection design, whether a four-way intersection or a t- intersection, an isolated intersection or part of a network.

The traffic conditions need to be taken into account, e.g., the vehicular volumes and turning movements.

Why Signalize

The convergence of traffic at an intersection raises the question of safety. This conflict may be corrected by separation in "space", e.g., construction of a bridge or an overpass, or freeways. This solution may be very expensive. Another means of correction is by separation of "time". This method utilizes a traffic control device to allocate the collision area to one traffic stream and then to another, thereby guaranteeing that no two cars occupy the same space at the same time.

The most basic type of traffic control signal uses a pretimed or fixed cycle. Since traffic conditions vary throughout the day, week and year, a number of timing plans must be provided for optimal traffic efficiency and safety. The three usual options of synchronization are for the a.m. rush periods, the p.m. rush periods, and for average conditions. The drawback to the pretimed control is that it is insensitive to actual traffic demands.

The more sophisticated traffic control is an actuated signal. This type responds to variable traffic demands on one leg (semi-actuated) or both legs (full-actuated) of the intersection.

With the advent of digital computers in the 1960's, their application to optimizing the traffic signal settings was investigated. In particular, the development of simulation as a tool for the study of traffic flow was fostered by the digital computer.

Why Simulate

One of the most difficult problems in traffic control is the translation of a real-world traffic situation into a mathematical-logical representation which can be executed with acceptable accuracy on a digital computer.

This mathematical model may be one of several types:

1. Iconic or physical models which are scaled-down models of bridges, roads, aircraft, etc.
2. Analog models based on the fact that two systems are governed by the same physical laws or the same differential equations.
3. Mathematical or analytical models in which the system is represented by a set of mathematical equations between those variables of interest and importance.
4. Simulation models which attempt to correctly represent the dynamic behavior of a system by moving it from state to state in terms of empirical data rather than theory or mathematical expressions. Simulation is normally achieved by building a computer model and moving it through time in order to study the performance of the entire system as the components interact.

Simulation modeling is advantageous when the system cannot be analyzed using direct or analytical methods. Additional reasons for simulation with regard to traffic control are:

1. Simulation is particularly important because mathematical laws of traffic are not directly usable, in their present state of development. No mathematical relationships exist by which various control parameters can be calculated for a given system structure and state of saturation.
2. Simulation provides considerable freedom to select and modify the representation of the control process. It is possible to introduce a large number of factors into the model, to break down complex processes, and to vary the constraints, also, a most important point, there is no restriction to a single performance function.
3. Simulation has other advantages of a less direct nature. The formulation of the model and its programming require precise and careful understanding of all aspects of the problem posed. Further, there is no reason to restrict simulation models to "off-line" operation. Simulation models could become an integral part of operating control schemes by providing optimization or quasi-optimization on-line, i.e., "fast-time" simulation.⁽¹⁾
4. The task of laying out and operating a simulation is a good way to systematically gather pertinent data. It makes for a broad education in traffic characteristics and operation.
5. Simulation of complex traffic operations may provide an indication of which variables are important and how they relate. This may lead eventually to successful analytic formulations.
6. In some problems, information on the probability distribution of the outcome of the process is desired, rather than only means and variances such as obtained in queueing.
7. A simulation can be performed to check an uncertain analytic solution.
8. Simulation is cheaper than many forms of experimentation.
9. Simulation gives an intuitive feeling for the traffic system being studied and is therefore instructive.

10. Simulation gives a control over time. Real-time can be compressed, and the results of a long amber phase can be observed in a few seconds of computer time.
11. Simulation is safe. It provides a means for studying the effect of traffic control measures on existing highways. The effect of signals, speed limits, signs, and access control all can be studied in detail without confusing or alarming drivers. Simulation offers the ability to determine in advance the effect of increased traffic flow on existing facilities. Probable congestion points and accident locations can be anticipated and changes in the physical design can be effected before the need is demonstrated through accident and congestion experience. (2)

SLAM

SLAM (Simulation Language for Alternative Modeling) is an advanced FORTRAN based language maintained and distributed by Pritsker & Associates, Inc., P.O. Box 2413, West Lafayette, Indiana 47906. SLAM allows simulation models to be built based on three different world views:

1. Event orientation - a system is modeled by defining the changes in state associated with the dependent variables at all possible event times. It requires a calendar of events to be maintained.
2. Activity scanning orientation - at each advance of the time parameter each potential activity is scanned to see if the necessary conditions are present for that activity to begin or end.
3. Process orientation - the logic associated with a sequence of events is generalized by a single symbol (or a single statement) or by a group of symbols or statements. These statements are used to model the flow of entities (e.g., automobiles) through the system.

CHAPTER II

MODEL

Project Description

The Florida Department of Transportation surveyed the intersection of Howell Branch Road and State Road 426. They approved the installation of a traffic signal.

This project simulates the flow of traffic at the intersection using the traffic flow data collected by the Department of Transportation, i.e., the traffic volumes and turning movements for both the morning peak and evening peak. The computer model is composed of two major parts: the first, made up of a series of networks (one each for eastbound, westbound and southbound traffic), to describe the traffic flow from the time it reaches the intersection to when it clears the intersection and the second part to operate the phasing of the traffic signal.

The Howell Branch Road-State Road 426 intersection is an isolated intersection, i.e., the closest signalized intersection is $\frac{1}{4}$ or $\frac{1}{2}$ mile or more away, and there are no good reasons for coordinating the traffic flow at the intersection with any others.

The basic problem in traffic control is to minimize the delay time and to make proper allocation of the right-of-way assignments so as to reduce congestion. Since the traffic signal controls this, a pretimed signal, a semi-actuated and full-actuated control are simulated to find

the best type of signal control.

A pretimed signal operates with a fixed total cycle length using preset fixed phase time interval durations, regardless of demand.

A semi-actuated signal insures a preset fixed phase length for the main traffic stream. The side street has a minimum green phase with a short extension time if there is still a demand; the right-of-way will revert back to the main traffic stream if there is no demand or if a preset maximum fixed length has been reached. The semi-actuated control is responsive to the one actuated approach.

The full-actuated signal operates on continuously variable cycle lengths. The phase green times are determined by the number and spacing of vehicles being detected on the various approaches; therefore, the green phase varies with demand (restrained by certain phase maximums) rather than being preset.

The eastbound traffic from State Road 426 crosses the path of the opposing westbound traffic when making a left turn onto Howell Branch Road. The effect this has on delay time at the intersection was investigated by modeling each of the three signal control types without a left turn arrow, with an exclusive arrow and with an exclusive-permissive left turn arrow.

The exclusive left turn arrow gives right-of-way to the left turn lane for a preset fixed time, then the flow of left-turn traffic must stop. Thus, the left turn can be made only during the arrow interval.

The exclusive-permissive left turn arrow permits the left turn for the length of the green arrow interval and also during the green phase whenever gaps in oncoming traffic allow turns to be made.

Each signal control type is simulated with various cycle lengths and variable green phases. The left turn arrow is preset for a fixed length of ten seconds.

The measure of delay time is defined to be the time at which a vehicle joins a queue at the intersection until it has the necessary right-of-way to proceed through the intersection. The level of congestion is determined by the maximum and the average number of vehicles waiting in each lane for a green phase and the right-of-way.

Inter-arrival Rates

Traffic flow cannot be described completely by simply measuring the mean and standard deviation for such characteristics as speed and volume. But given a probability or frequency distribution, the process can be studied completely.

Probability distributions are grouped into two general categories:

1. Counting distributions which describe discrete (i.e., have only integer values) events such as the number of cars counted during an interval of time.

2. Interval distributions which describe continuous (i.e., fractional values are permitted) events such as the time between arrivals of vehicles at a given point.

The negative exponential distribution is often used to study headways (the interval of time between front bumpers of successive cars as they pass a point on the road) in a traffic stream. The exponential distribution is used to represent situations in which the events are distributed randomly.

Traffic flow is frequently considered to be random. This assumption is generally considered to be valid for uninterrupted flow rates of 500 vehicles per lane per hour or less.(2)

The data collected by the Department of Transportation indicates that the flow rate is less than 500 vehicles per lane per hour for the Howell Branch Road-State Road 426 intersection. This reinforces the assumption stated above to use the negative exponential distribution for this simulation. Also, since it is an isolated intersection, not tied in to a network, the flow of traffic is independent of other traffic signals which may cause the arrival of vehicles in groups at each signal change.

Assumptions

A number of assumptions were required in order to simplify the model. These are details which may have over-complicated the program or factors which may be subjective or unmeasurable. The model still provides a reasonably accurate simulation without excessive and extraneous factors.

The assumptions made are:

1. Drivers obey traffic regulations, such as not entering the intersection on the amber light and turning left from the left turn lane.
2. Vehicles are of equal size; moving at the same speed.
3. There are no break-downs or emergency situations to block the intersection.
4. There are no pedestrians or bicycles requiring special consideration or causing a hindrance.
5. Westbound, straight-through traffic on State Road 426 selects the lane with the shorter queue or the right lane in the case of equal lane length's.

6. Data used (e.g., vehicle volume turning movement, time to clear the intersection) is that collected by the Department of Transportation for the Howell Branch Road-State Road 426 intersection.

7. Right turn on red is permitted, provided the intersection is free for use.

8. Since State Road 426 is not a high speed road, the full-actuated signal will change phase without affecting safety conditions, if there is a demand detected on the opposing road.

9. The eastbound traffic has two lanes for straight-through traffic. These two lanes merge into one part-way through the intersection. The unpredictable nature of the drivers necessitated modeling the two, straight-through, eastbound lanes as one lane.

10. The time (in seconds) to clear the intersection is 2.2 for both straight-through and right-turning traffic. (See Figures 2-4). The time (in seconds) to clear the intersection is 2.5 for left-turning traffic (See Figures 3 and 4).

Traffic Networks

The traffic flow is dependent on the availability of necessary resources. For this SLAM project, a green light and a left turn arrow are resources. The intersection has been subdivided into various zones (See Figure 1) which are also treated as resources. In order for a vehicle to proceed through the intersection it must have use of a combination of these resources. The vehicle must have one green light resource (or left turn arrow resource, in some cases). For right-turn vehicles this green light resource is not necessary. The vehicle must

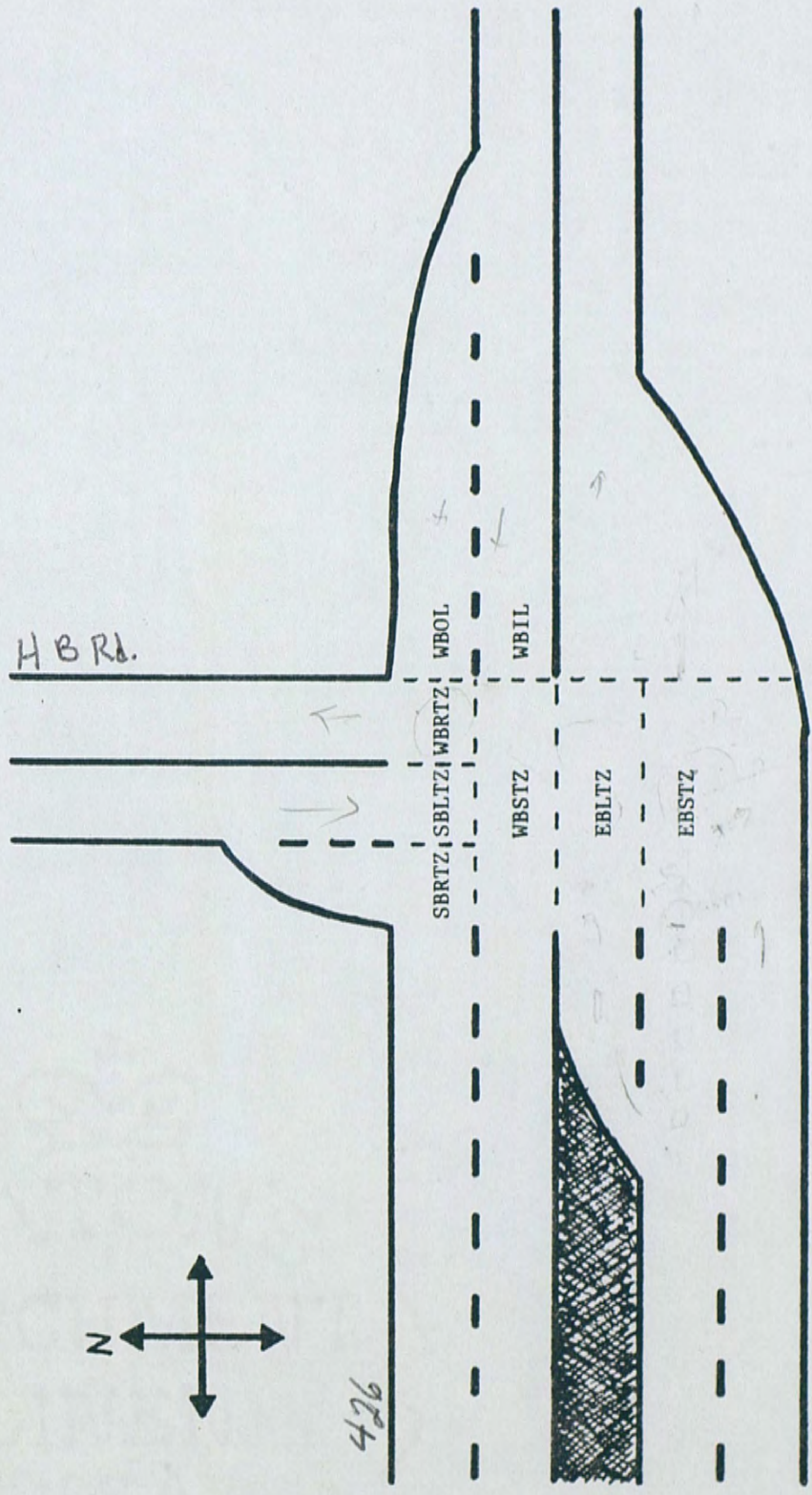

Figure 1. Zones of the Howell Branch Road-State Road 426 intersection

also have use of the zone resources through which it must pass to clear the intersection. Once a vehicle has the necessary combination of resources, it will proceed through the intersection in a certain length of time, depending on whether the car is turning or going straight. After it leaves the intersection, the vehicle frees the use of the resources so that the next vehicle may have use of them. The delay time is the time from when the vehicle joins a queue at the intersection and attains the necessary combination of resources in order to proceed through the intersection.

Westbound Traffic (See Figure 2)

Vehicles are generated using the exponential distribution with a mean calculated from the Department of Transportation data. A certain percentage of these cars will be turning right; a percentage will continue straight through the Howell Branch Road-State Road 426 intersection. As the vehicles are generated, ATRIB (1) records the time of creation. Next, ATRIB (2) takes on the value of 1 if the vehicle is designated to go straight and takes on the value of 2 for those vehicles that will be making a right turn onto Howell Branch Road. At this time a decision must be made as to which lane (zone resource) the vehicle will use. If the vehicle's ATRIB (2) is equal to 2 (making a right turn), that car must use the outside lane (WBOL resource). If ATRIB (2) has the value of 1, the vehicle may use either the inside lane (WBIL resource) or the outside lane (WBOL). The decision is made based on the assumption that the vehicle will enter the shorter queue; in the case of both queues having equal length, the car will choose the outside lane (WBOL). For

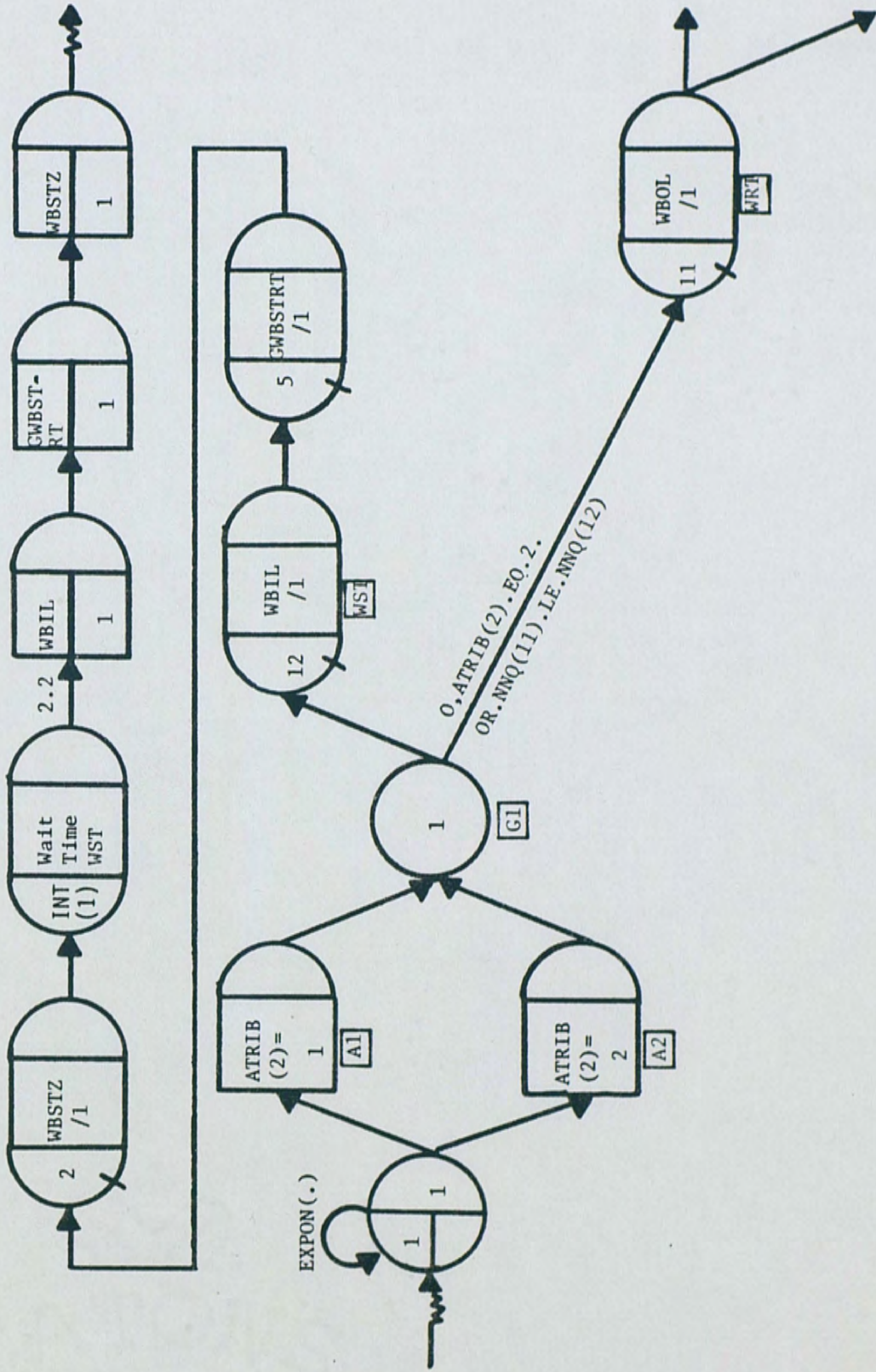

Figure 2. Westbound traffic

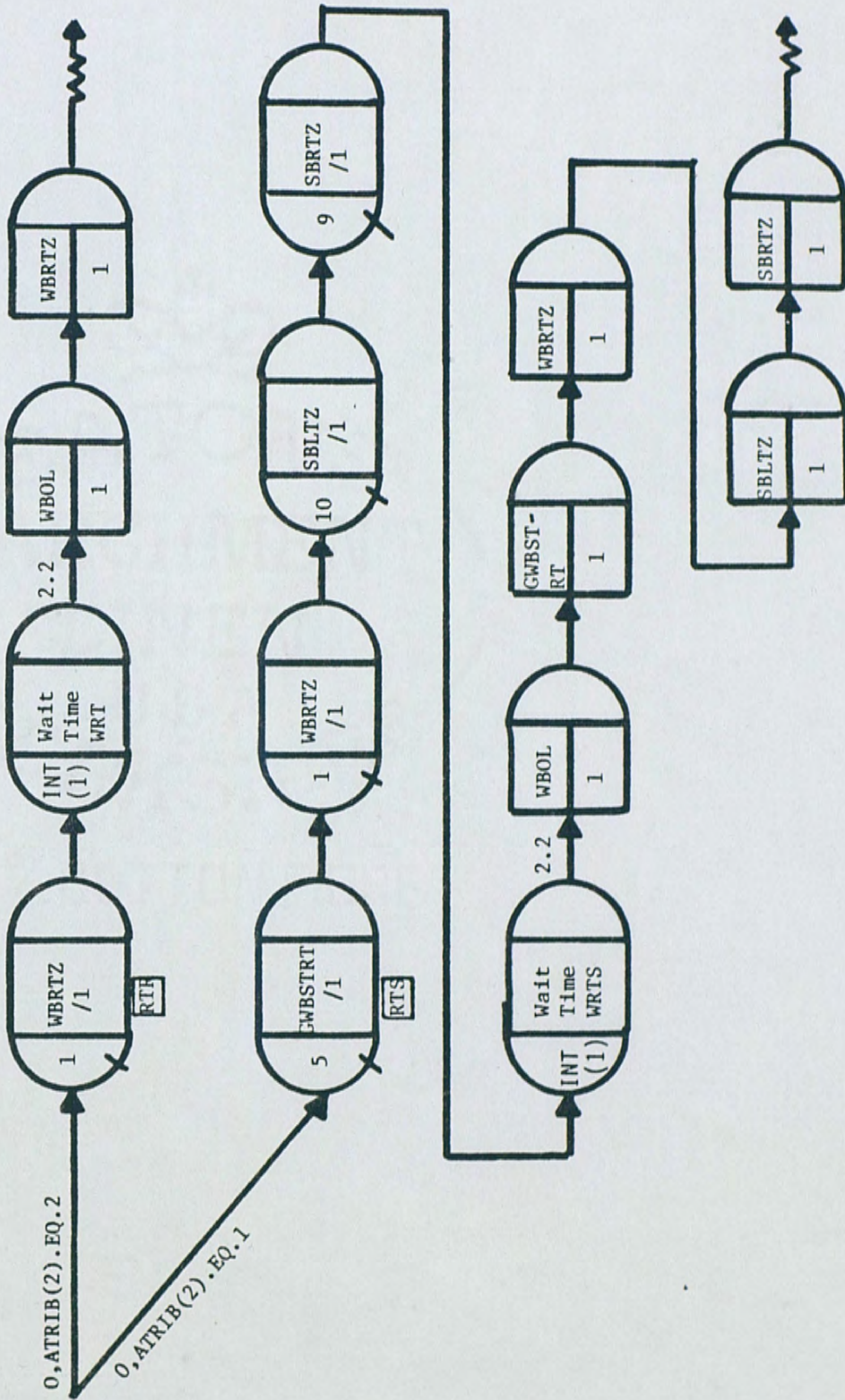

Figure 2. (Continued)

those vehicles in the inside lane (WBIL), the first car must wait for the green light (GWBSTRT resource) and use of the lane (WBSTZ resource). When the vehicle acquires use of both of these resources, the delay time is collected (the difference between the current time and the time the vehicle reached the intersection). After 2.2 seconds the car clears the intersection and frees the resources (use of inside lane, use of green light, and use of the intersection). The next vehicle in the inside lane (WBIL) is then able to pass through the intersection if the green light resource is still available. This is dependent on the traffic signal.

Those vehicles in the outside lane (WBOL) may be turning right or going straight on State Road 426, depending on the value of ATRIB(2). If the first car in the queue (WBOL) is turning right, the green light resource is not necessary. If the intersection is clear, the vehicle takes use of that resource (WBRTZ), collects the delay time and proceeds through the intersection in 2.2 seconds. The resources (use of the outside lane, and use of the turning area) are freed for the next vehicle to use. If the first car in the queue (WBOL) is going straight, there must be a green light (GWBSTRT) and the intersection must be clear (WBRTZ, SBLTZ and SBRTZ resources). After acquiring use of the necessary resources and after collecting the delay time, the vehicle leaves the intersection (2.2 seconds) and frees the resources for the next car.

Eastbound Traffic (See Figure 3)

The eastbound traffic is generated by the exponential distribution with a mean calculated from the Department of Transportation data. A

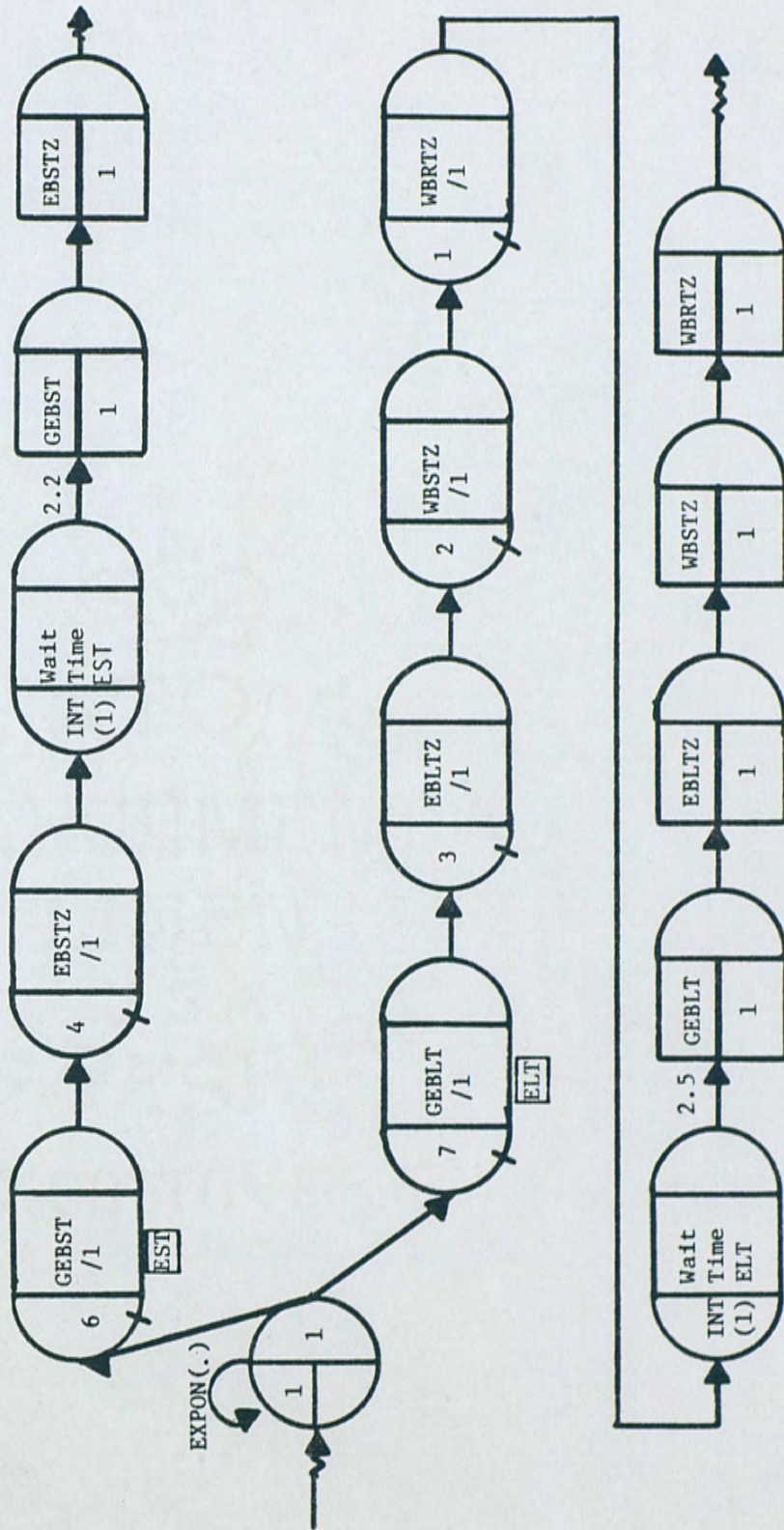

Figure 3. Eastbound traffic

certain percentage will enter the left turn lane, the others will join the queue to go straight on State Road 426. Those vehicles going straight must first wait for a green light (GEBST resource). When the first car in the queue gets this resource and also use of the intersection (EBSTZ resource), the delay time is collected before passing through the intersection. The resources (GEBST and EBSTZ) are then freed (2.2 seconds).

Those vehicles in the left turn lane must wait for either a green light or a left turn arrow, depending on the traffic signal phasing. When the lead vehicle acquires the necessary resources (GEBLT, EBLTZ, WBSTZ, WBRTZ), the delay time is collected, the vehicle moves through the intersection in 2.5 seconds and frees the resources for the next vehicle to use.

Southbound Traffic (See Figure 4)

The southbound traffic is also generated using the exponential distribution with the calculated mean. A certain percentage of the vehicles will turn left onto State Road 426 and a percentage will turn right onto State Road 426. Those vehicles turning right may proceed without a green light provided the intersection is clear. Once the lead vehicle acquires use of the right turn lane (SBRTZ resource), the delay time is collected, the vehicle makes the turn and 2.2 seconds later frees the area (SBRTZ) for future use.

Those vehicles turning left onto State Road 426 must wait for the green light (which in this model is the RLSB resource). When the RLSB resource becomes available, the first vehicle to enter that queue assumes use of it. The car then enters the intersection, provided it is clear,

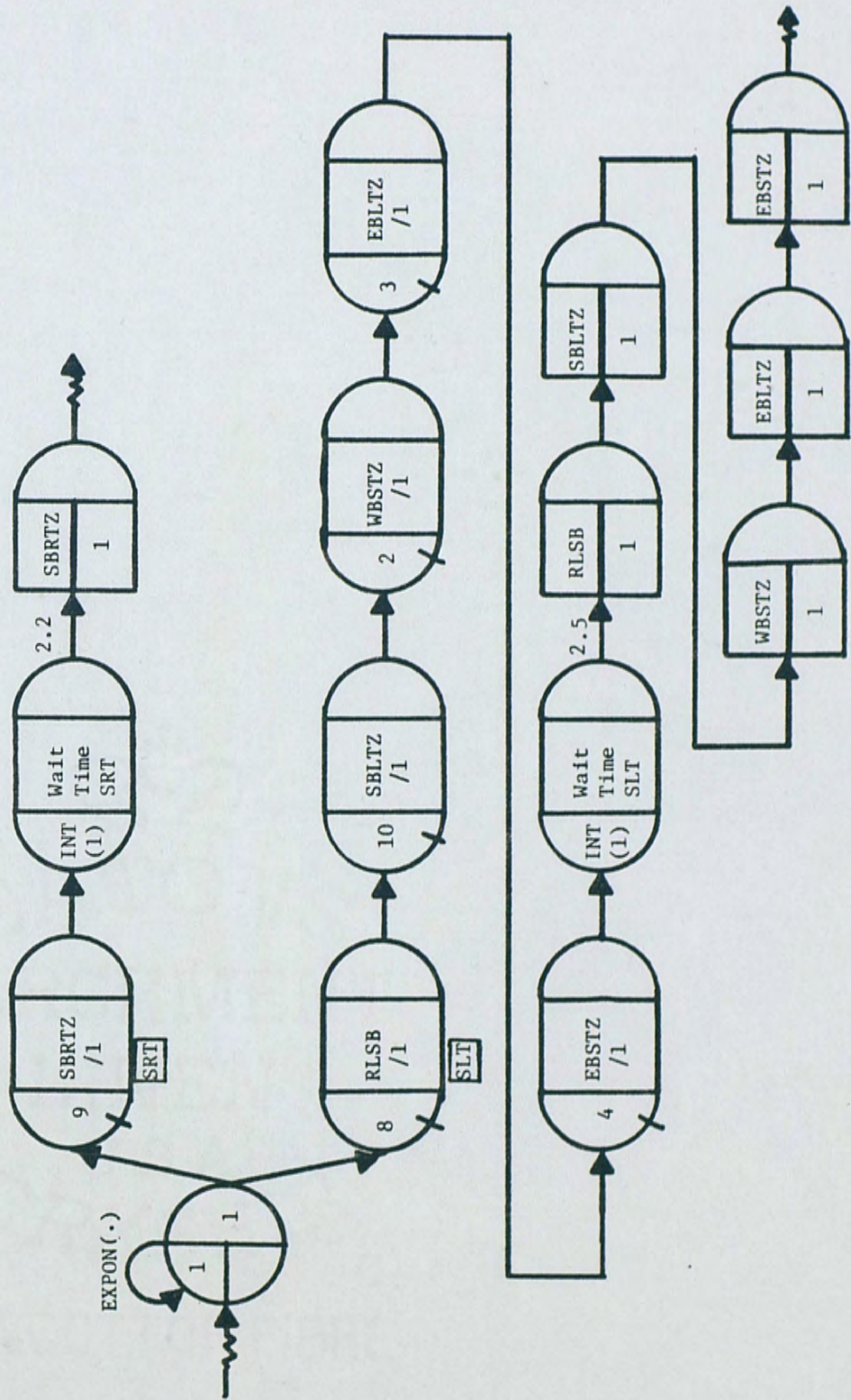

Figure 4. Southbound traffic

and grabs use of the SBLTZ, WBSTZ, EBLTZ, and EBSTZ resources. The wait time is collected, the left turn is made in 2.5 seconds, then the resources (RLSB, SBLTZ, WBSTZ, EBLTZ and EBSTZ) are freed. The next vehicle in the left turn lane may proceed provided the traffic signal is still green (RLSB resource).

Traffic Signals

There are two lanes for the westbound traffic on State Road 426 at the Howell Branch intersection. Therefore, there must be two resources of the green signal (GWBSTRT), one for each lane. The eastbound traffic has one resource of the green signal (GEBST) for the straight-through traffic and one resource (GEBLT) for the left-turning vehicles. The southbound traffic on Howell Branch Road has the right-of-way when the red light is showing for the State Road 426 traffic (i.e., the green light is showing for the Howell Branch Road traffic). Since only the southbound, left-turn traffic requires a green light to go, one resource of RLSB is necessary.

The length of each phase is controlled by global variables. XX(1) defines how long the green phase is on for the east-west traffic, XX(2) determines the length of the amber phase for the east-west traffic, XX(3) designates the length of the red phase for the east-west traffic, and XX(4) controls the left turn phase for the eastbound traffic turning left onto Howell Branch Road.

Pretimed/No Left Turn Arrow (See Figure 5)

At the start of simulation, each lane of traffic on State Road 426 has available one resource of green light (GEBST/1, GEBLT/1, GWBSTRT/2).

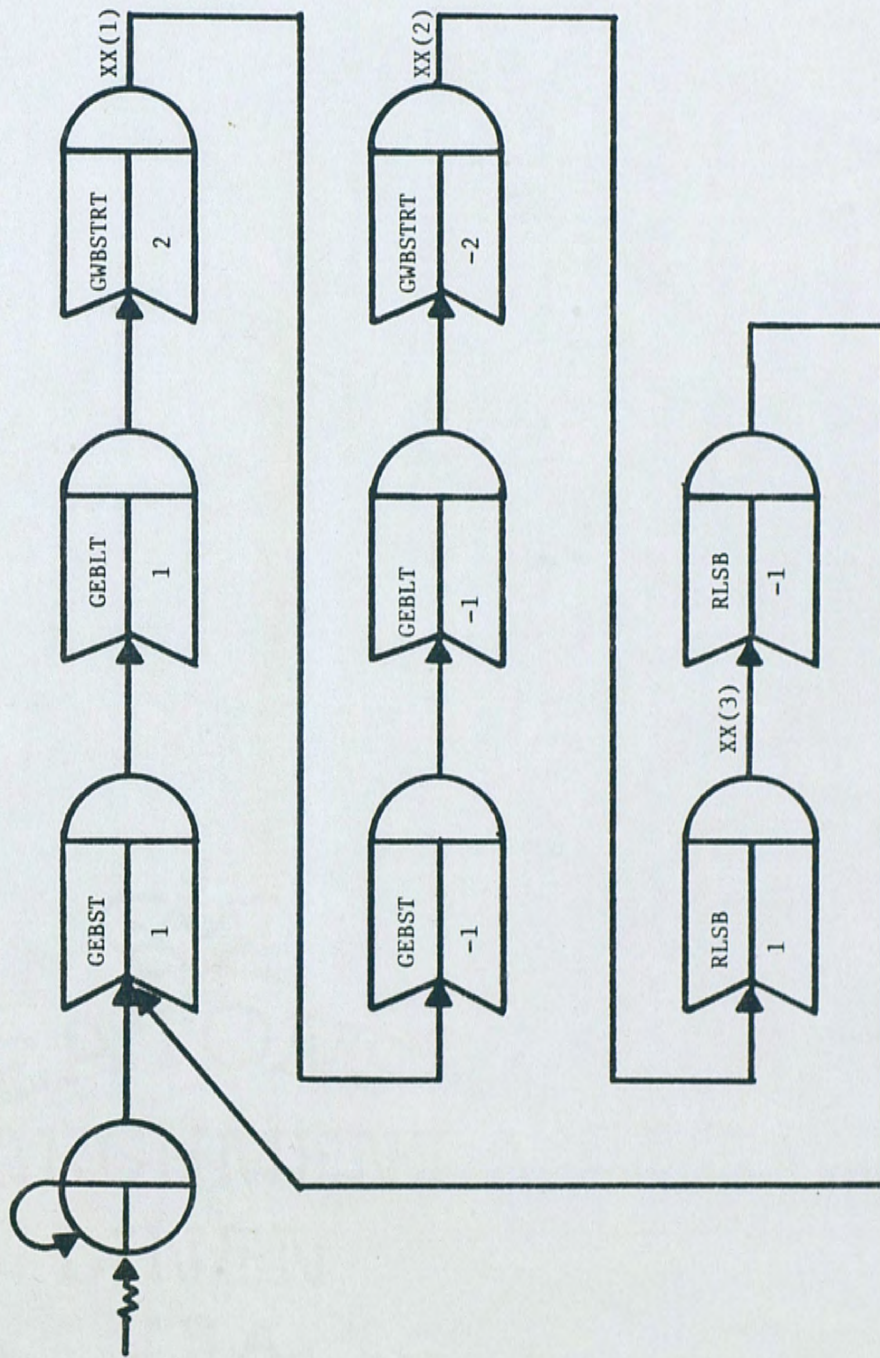

Figure 5. Pretimed/no left turn arrow

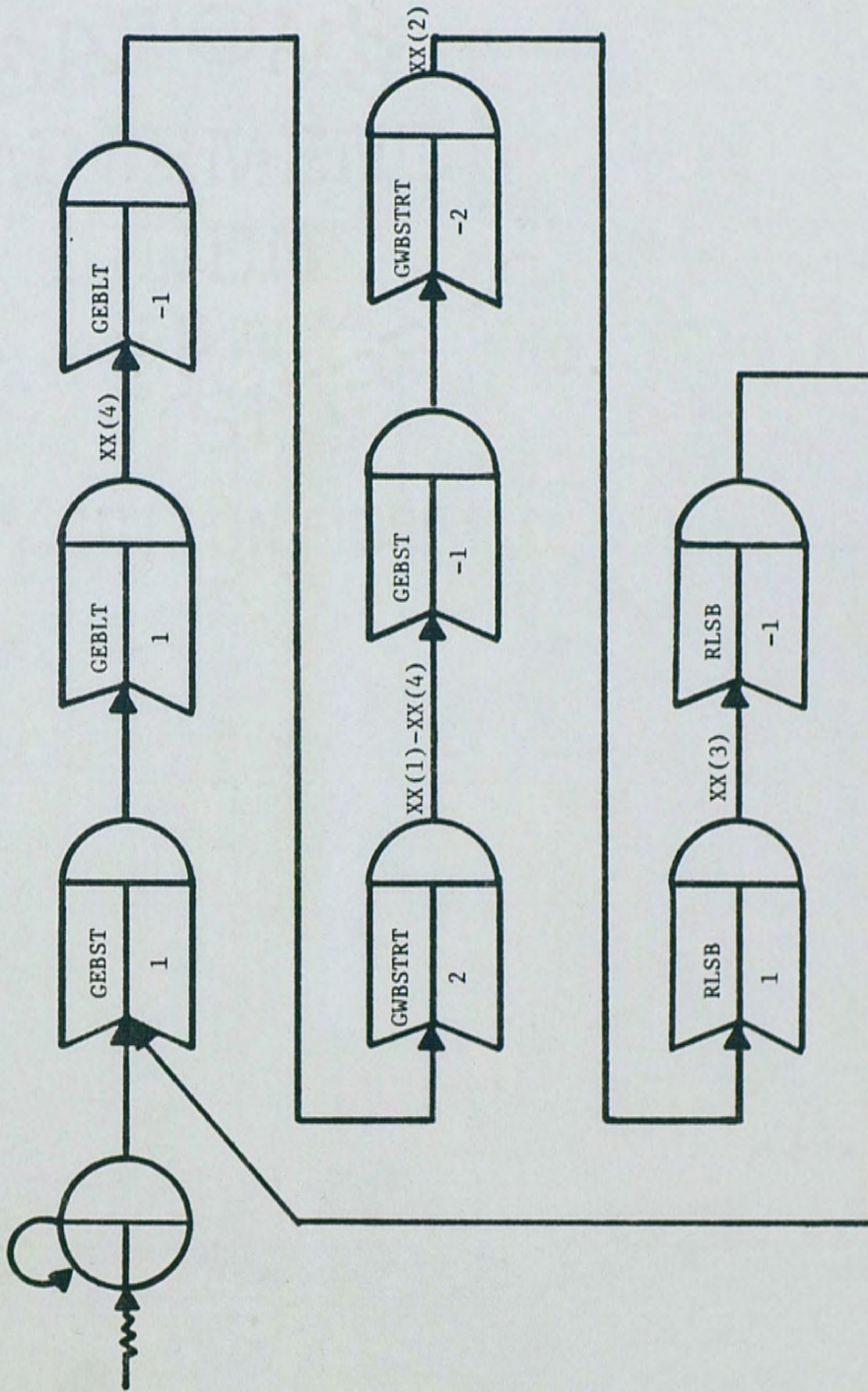

Figure 6. Pretimed/exclusive left turn arrow

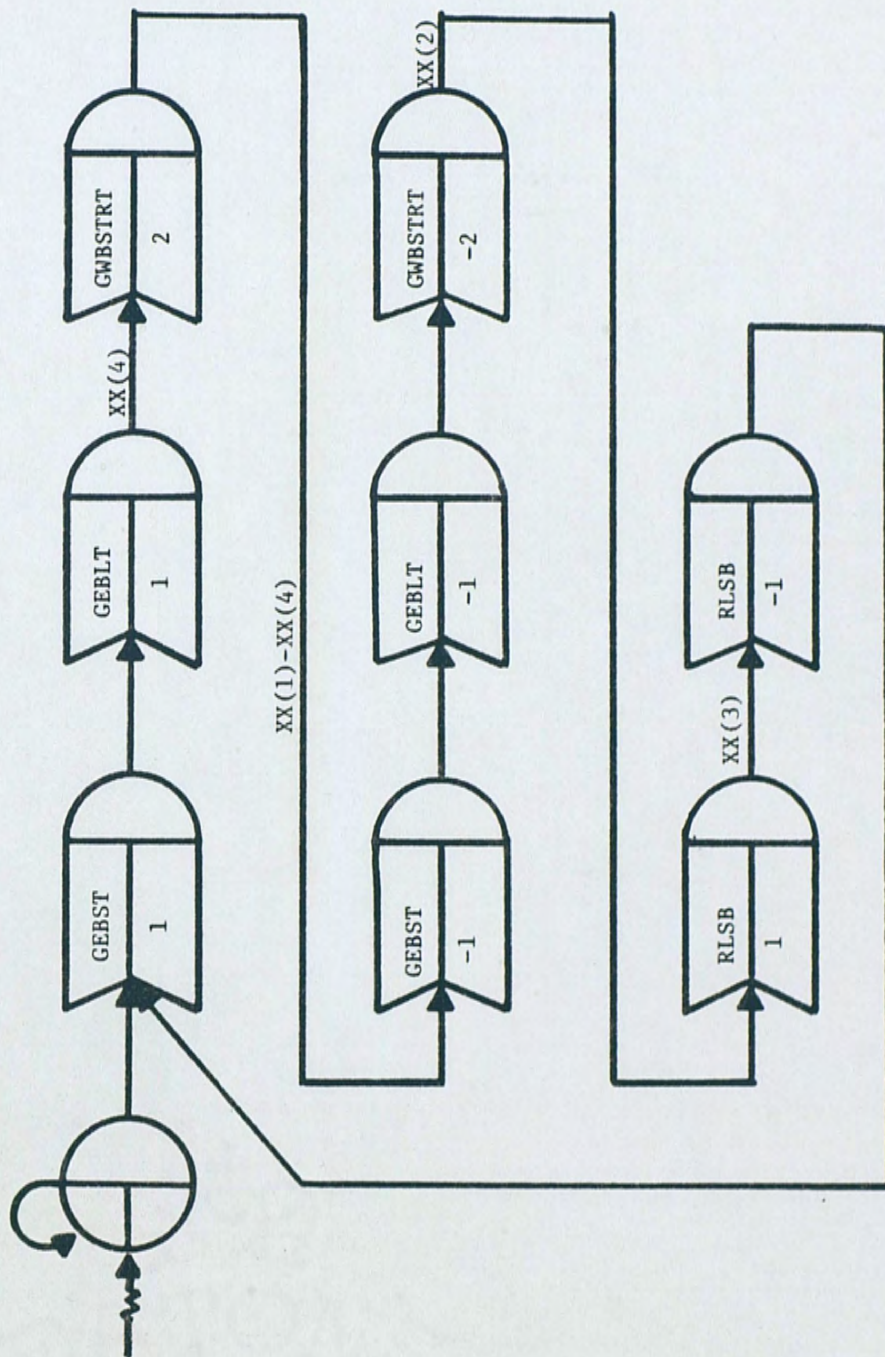

Figure 7. Pretimed/exclusive-permissive left turn arrow

After a fixed length of time (XX(1)), the availability of these resources are taken away (BEBST/-1, GEHLT/-1, GWBSTRT/-2). The amber light shows for a fixed length of time (XX(2)) and then one resource of red light (RLSB/1) is made available for a time of XX(3) length. The red light changes (RLSB/-1) and the cycle begins again.

Pretimed/Exclusive Left Turn Arrow (See Figure 6)

At the start of simulation, the eastbound, straight-through lane and the left-turn lane on State Road 426 each have one resource of green light (GEBST/1, GEHLT/1). After XX(4) seconds, the left-turn resource is taken away (GEHLT/-1). The westbound traffic on State Road 426 is allocated two units of green light (GWBSTRT/2), one for each lane. For the remaining time of the green phase (XX(1)-XX(4)), traffic moves on State Road 426 except for the lane to turn left onto Howell Branch Road. The resources (GEBST/-1 and GWBSTRT/-2) are taken away, the amber phase passes, the red light (RLSB/1) shows for the preset, fixed time (XX(3)), and the cycle begins again.

Pretimed/Exclusive-permissive Left Turn Arrow (See Figure 7)

At the start of simulation, the eastbound, straight-through lane and the left-turn lane on State Road 426 each have a resource of green light (GEBST/1, GEHLT/1). After a time of XX(4) seconds the two westbound lanes of State Road 426 are each allocated one unit of green light (GWBSTRT/2) for the remaining time (XX(1)-XX(4)) of the green phase. Then the amber phase (XX(2)) brings traffic on State Road 426 to a halt. The red phase comes on for XX(3) seconds allowing the right-of-way to the Howell Branch Road traffic before starting the cycle again.

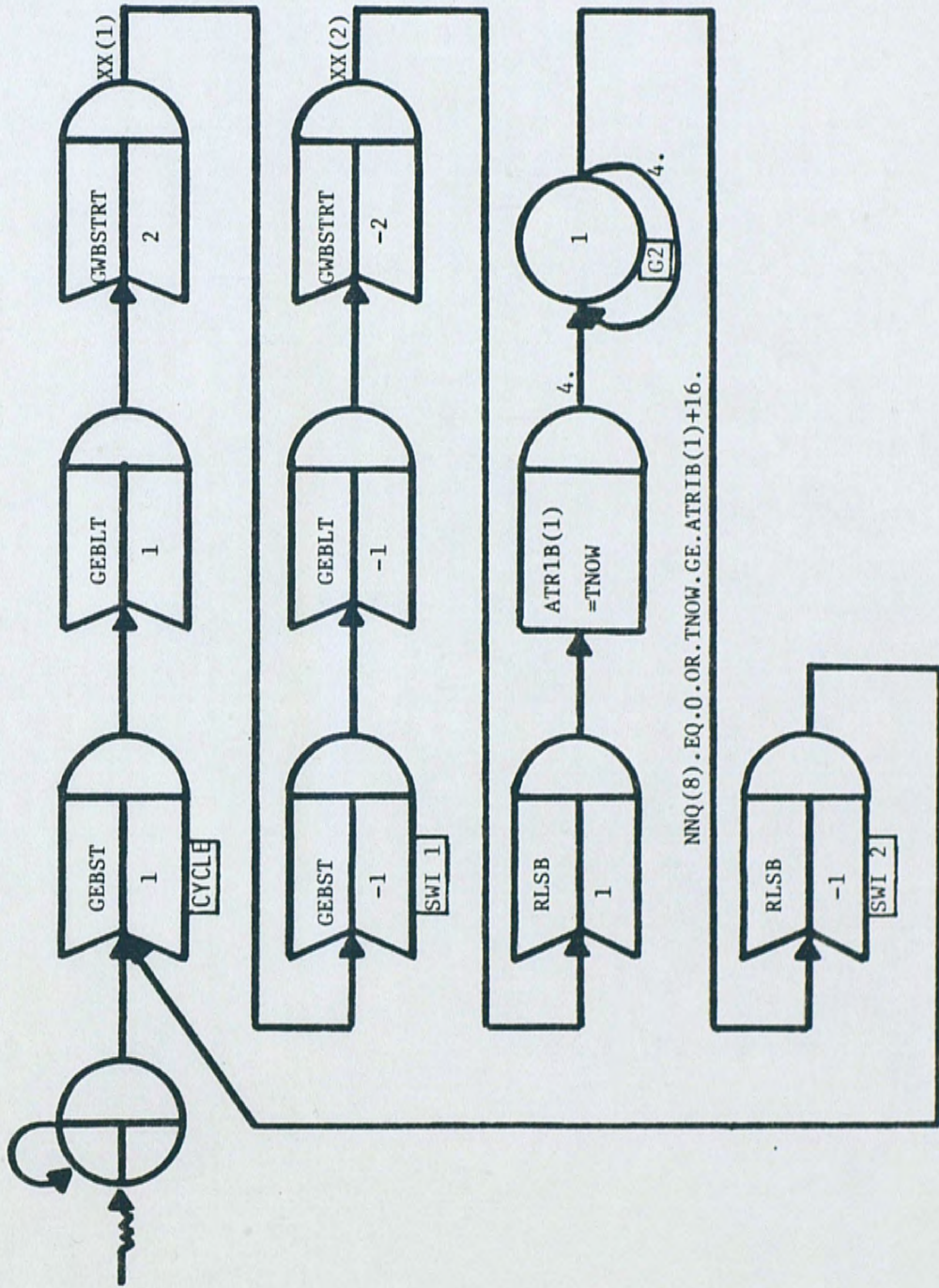

Figure 8. Semi-actuated/no left turn arrow

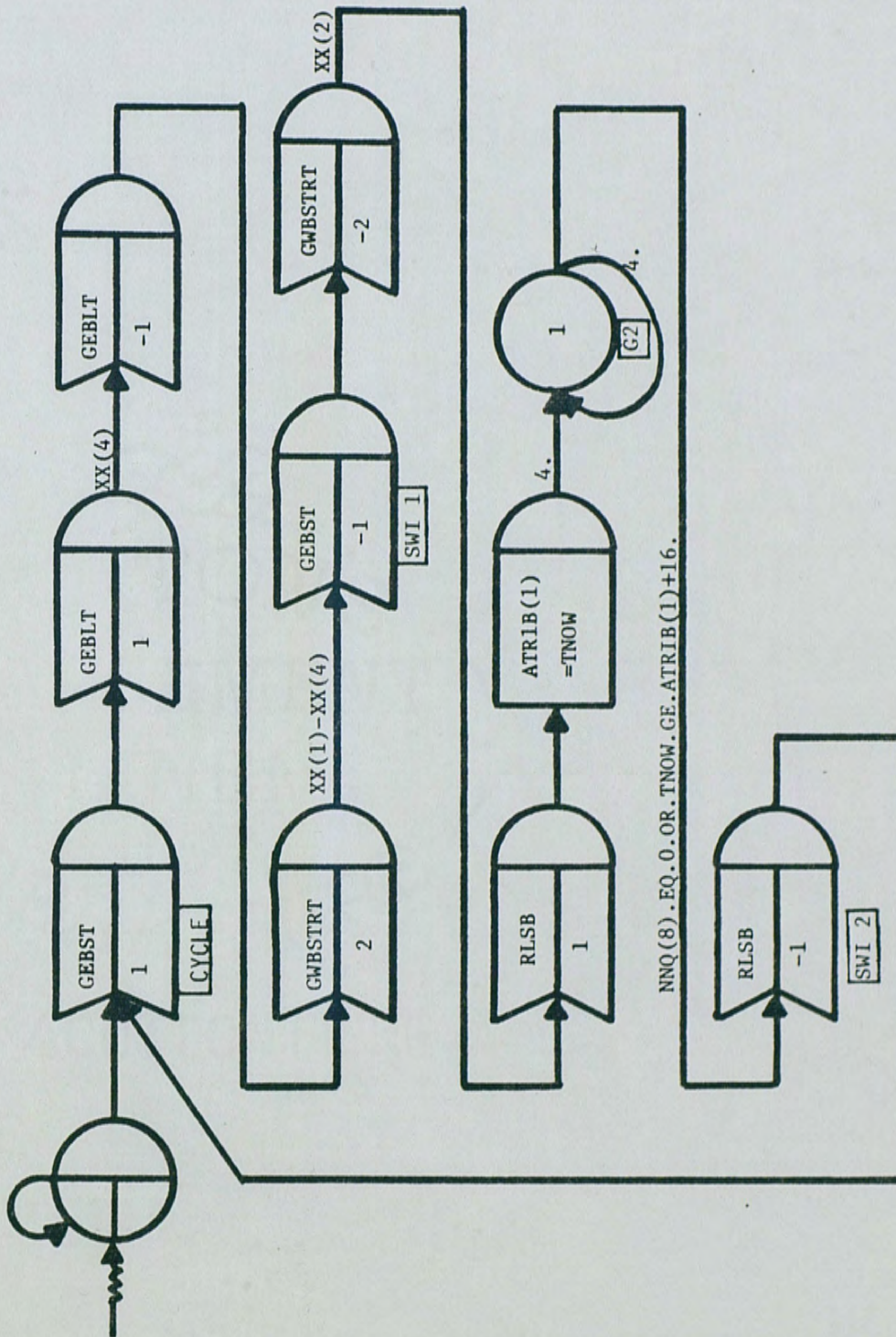

Figure 9. Semi-actuated/exclusive left turn arrow

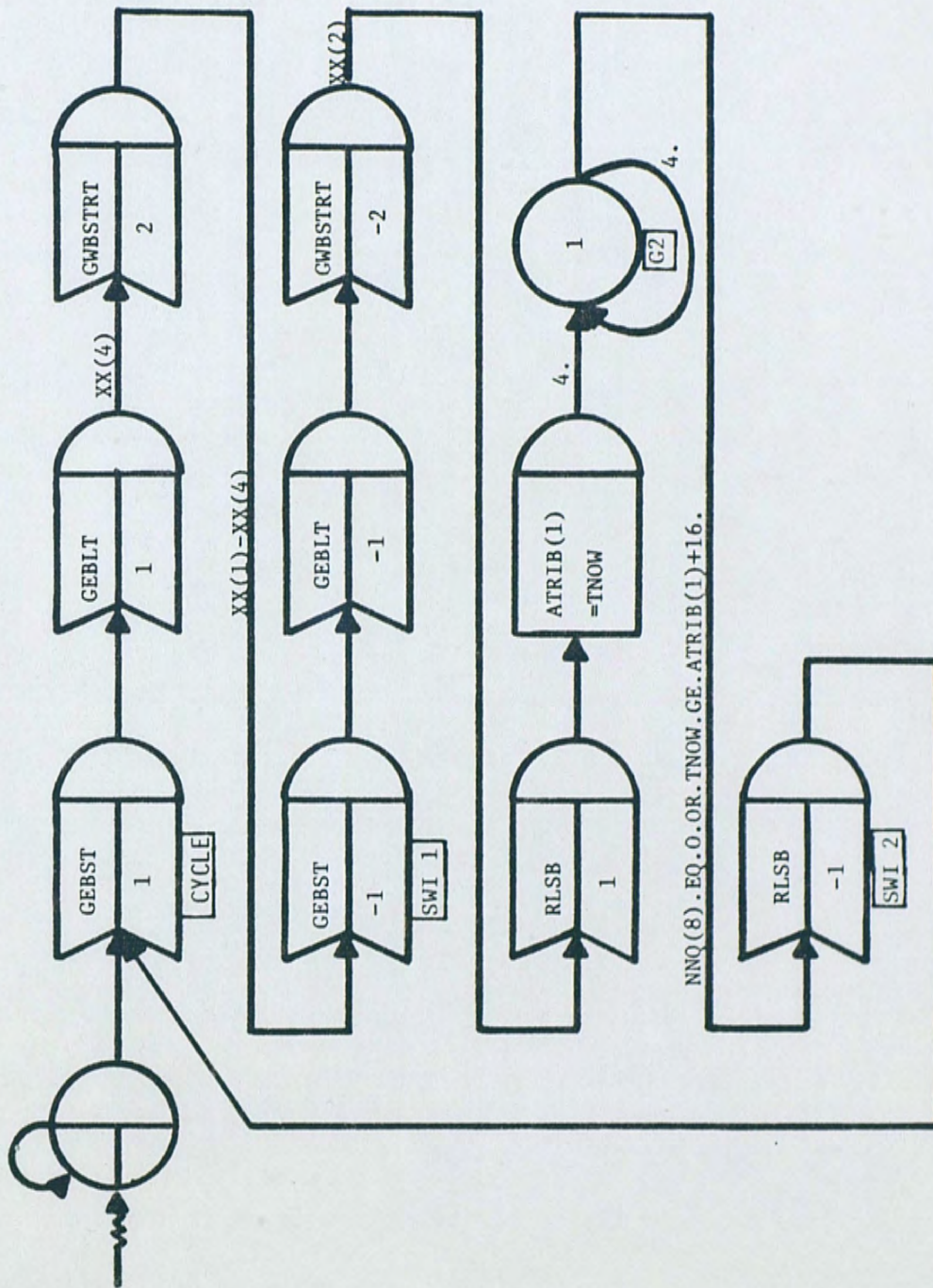

Figure 10. Semi-actuated/exclusive-permissive left turn arrow

Semi-actuated/No Left Turn Arrow (See Figure 8)

See Pretimed/No Left Turn Arrow for explanation of the green phase. The amber light shows for a fixed length of time (XX(2)) and then one resource of red light (RLSB/1) is made available, allowing traffic on Howell Branch Road to flow. After 4. seconds the signal control has two options. If it detects another vehicle waiting to turn left onto State Road 426 from Howell Branch Road, the red resource is made available for another 4. seconds. If no car is detected or the red resource has been available for a maximum 16. seconds, the red phase switches off, the green phase comes on, and the cycle repeats again.

Semi-actuated/Exclusive Left Turn Arrow (See Figure 9)

See Pretimed/Exclusive Left Turn Arrow for explanation of the green phase. For the amber and red phase, see Semi-actuated/No Left Turn Arrow.

Semi-actuated/Exclusive-permissive Left Turn Arrow (See Figure 10)

See Pretimed/Exclusive-permissive Left Turn Arrow for explanation of the green phase. For the amber and red phase, see Semi-actuated/No Left Turn Arrow.

Full-actuated/No Left Turn Arrow (See Figure 11)

At the start of simulation, each lane of traffic on State Road 426 has available one resource of green light (GEBST/1, GEBLT/1, GWBSTRT/2). After 6. seconds the signal control has two options. If there are no vehicles detected on Howell Branch Road, all the resources are made available for another 4. seconds. If a vehicle is detected waiting on

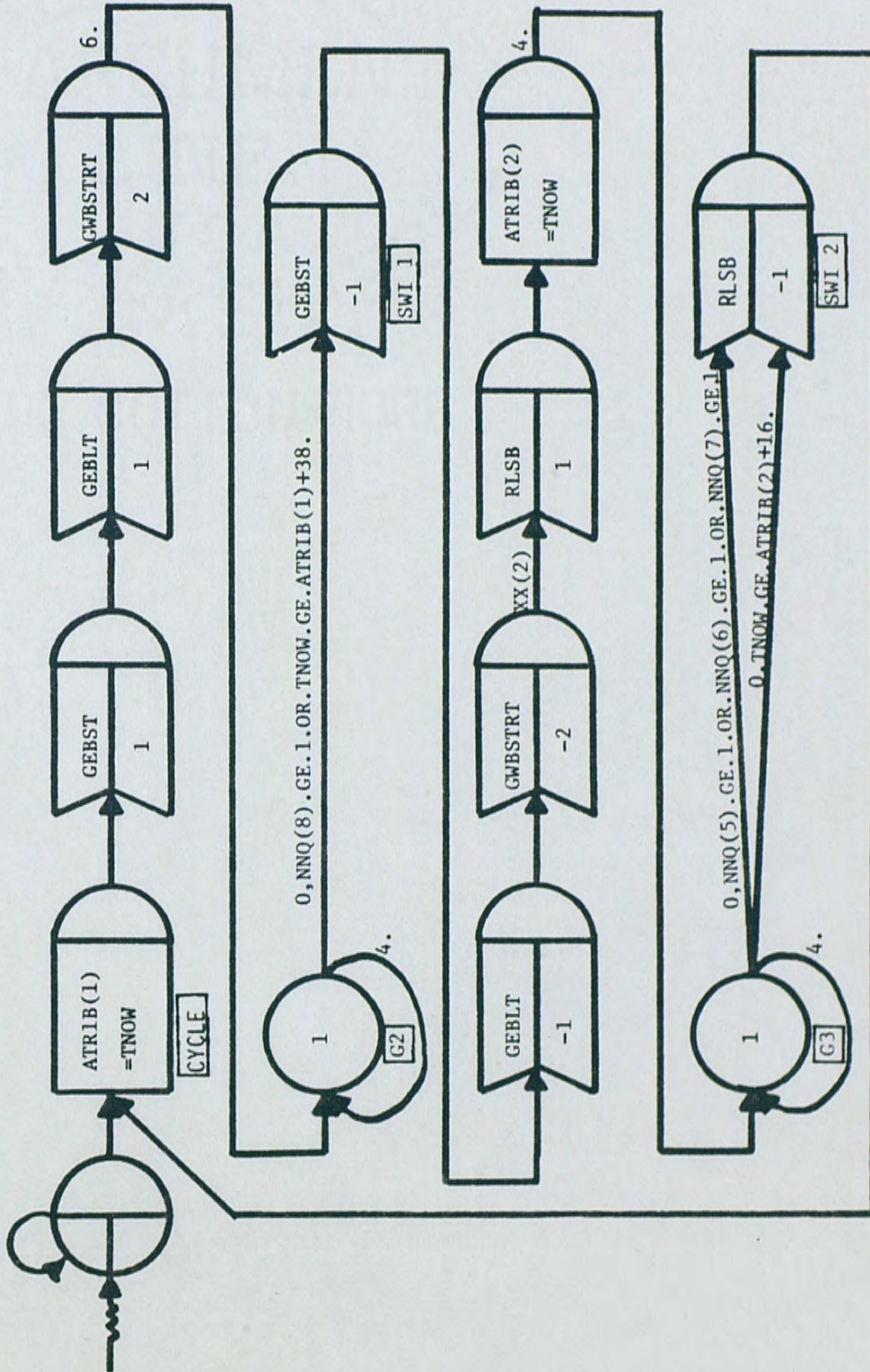

Figure 11. Full-actuated/no left turn arrow

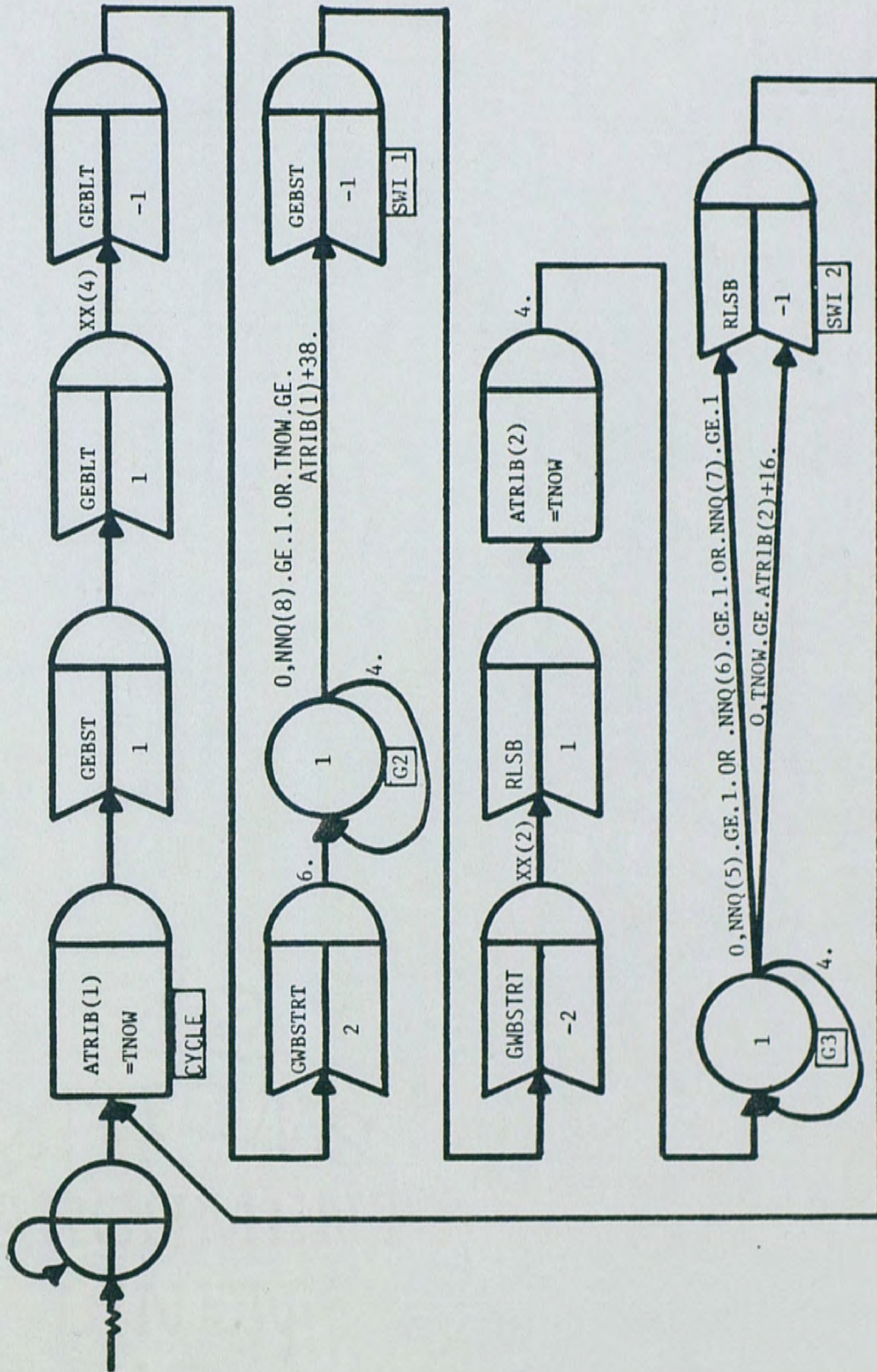

Figure 12. Full-actuated/exclusive left turn arrow

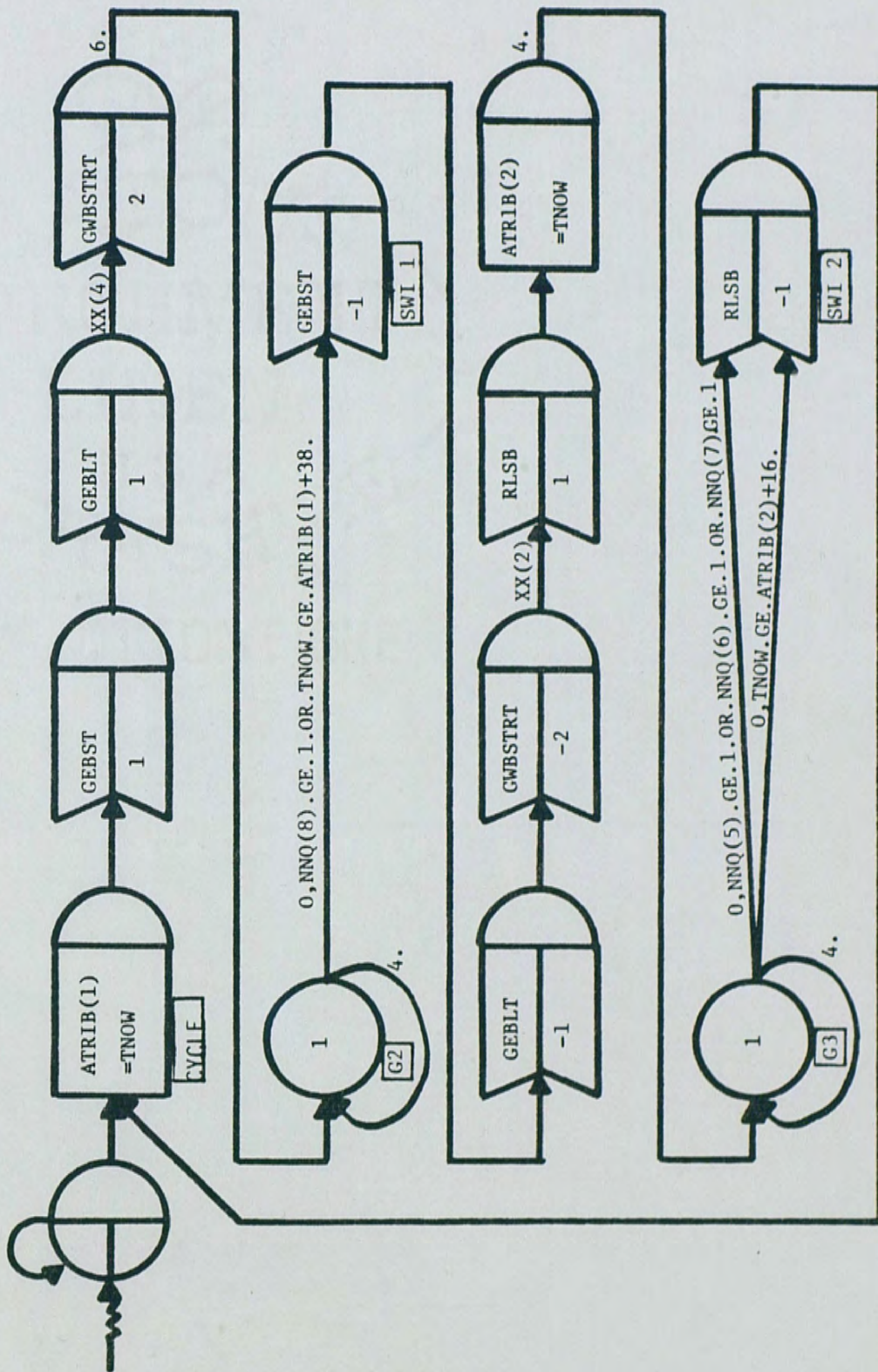

Figure 13. Full-actuated/exclusive-permissive left turn arrow

Howell Branch Road for use of intersection or the green phase has been on for a maximum 38. seconds, the traffic signal removes use of the green light resources. The amber phase shows for XX(2) seconds; then one unit of red resource (RLSB/1) is allocated for the Howell Branch Road traffic. After 4. seconds the signal control has two options. If no vehicle is detected on State Road 426, the red phase is extended another 4. seconds. If a vehicle is detected waiting on State Road 426 for use of the intersection or the red phase has been on for a maximum 16. seconds, the red phase will switch off, and the green phase will start the cycle again.

Full-actuated/Exclusive Left Turn Arrow (See Figure 12)

At the start of simulation, the eastbound, straight-through lane and the left-turn lane on State Road 426 each have one resource of green light (GEBST/1, GEBLT/1). After XX(4) seconds the left-turn resource is taken away. The westbound traffic on State Road 426 is allocated two units of green light, one for each lane. After 6. seconds the signal control has two options. See Full-actuated/No Left Turn Arrow for explanation of the remaining part of the cycle.

Full-actuated/Exclusive-permissive Left Turn Arrow (See Figure 13)

At the start of simulation, the eastbound, straight-through lane and the left-turn lane on State Road 426 each have a resource of green light (GEBST/1, GEBLT/1). After a time of XX(4) length, two resources of green light (GWBSTRT/2) are allocated, one for each lane of State Road 426 westbound traffic. After 6. seconds the signal control has two options. See Full-actuated/No Left Turn Arrow for explanation of the remaining part of the cycle.

CHAPTER III

CONCLUSION

Verification

Verification of a simulation model is that process of establishing that the computer program executes as the user intended. This is typically done by manual checking of calculations.

Figures 14 - 19 show a time progression of a deterministic simulation run for a pretimed signal with an exclusive left turn arrow. The cycle length is 55 seconds. The green phase is 41.25 seconds (the first 10 seconds designate an exclusive left turn arrow for the eastbound traffic). The amber phase is 5.5 seconds and the red phase is 8.25 seconds long.

So that for this simulation, the signal phasing is:

<u>Traffic Movement</u>	<u>Signal Phases</u>
eastbound-straight <u>and</u> left-turning	0. - 10 secs.
eastbound-straight <u>and</u> both westbound	10. - 41.25
amber - no traffic movement	41.25 - 46.75
southbound - left <u>and</u> right-turning	46.75 - 55.
eastbound - straight <u>and</u> left-turning	55. - 65. secs.
eastbound - straight <u>and</u> both westbound	65. - 96.25
amber - no traffic movement	96.25 - 101.75
southbound - left <u>and</u> right-turning	101.75 - 110.

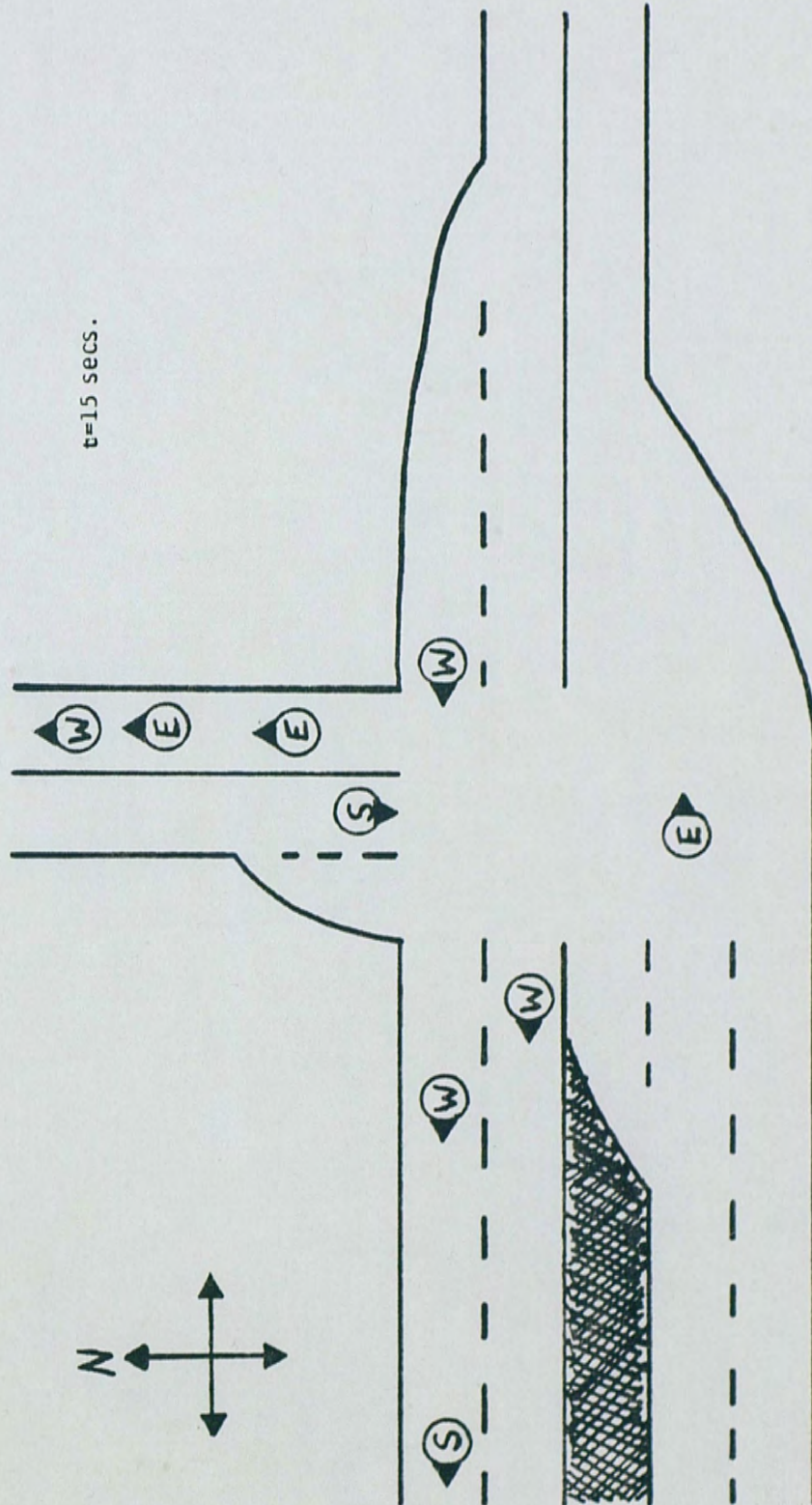

Figure 14. Time lapse of a deterministic simulation run

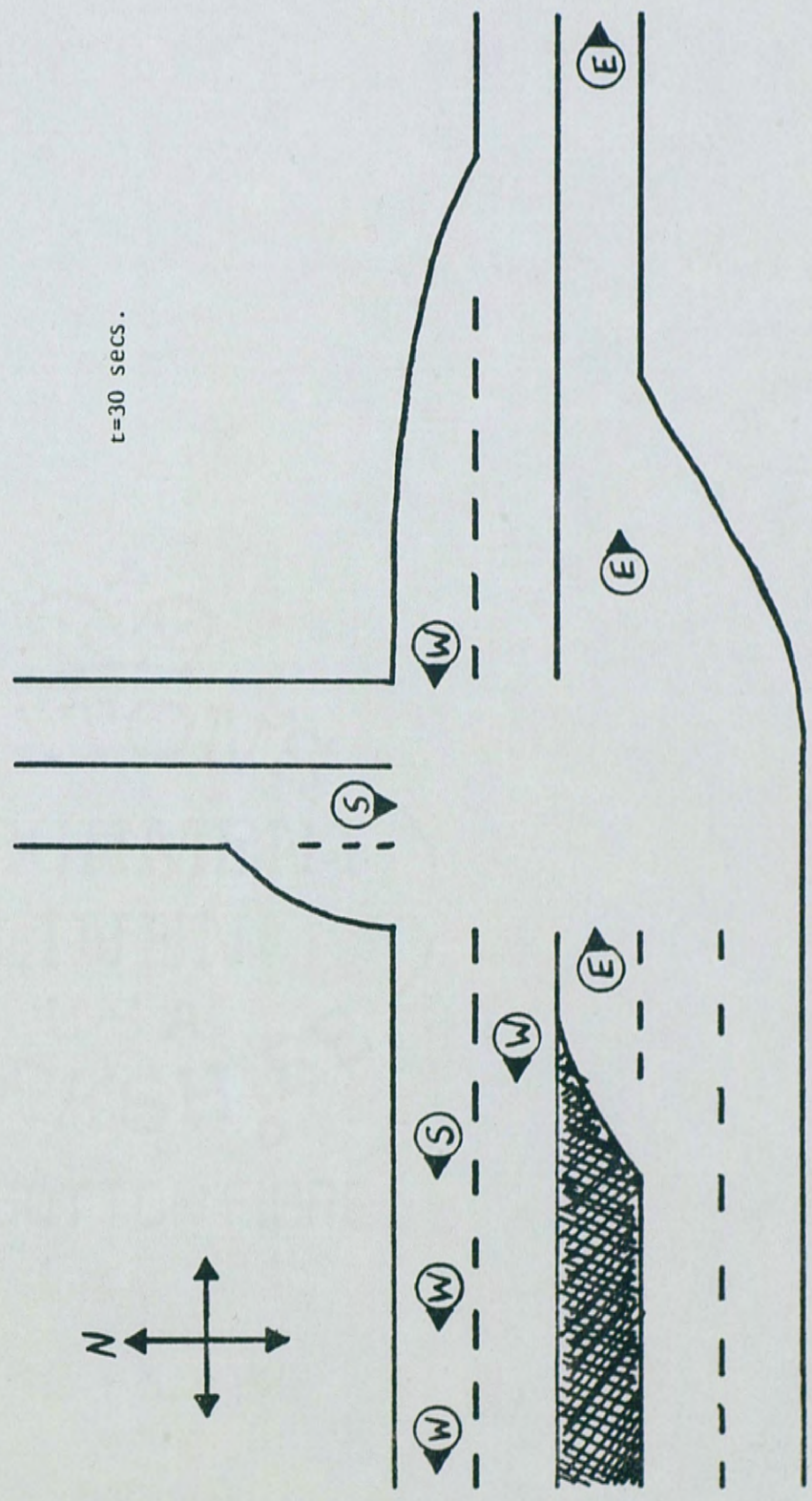

Figure 15. Time lapse of a deterministic simulation run

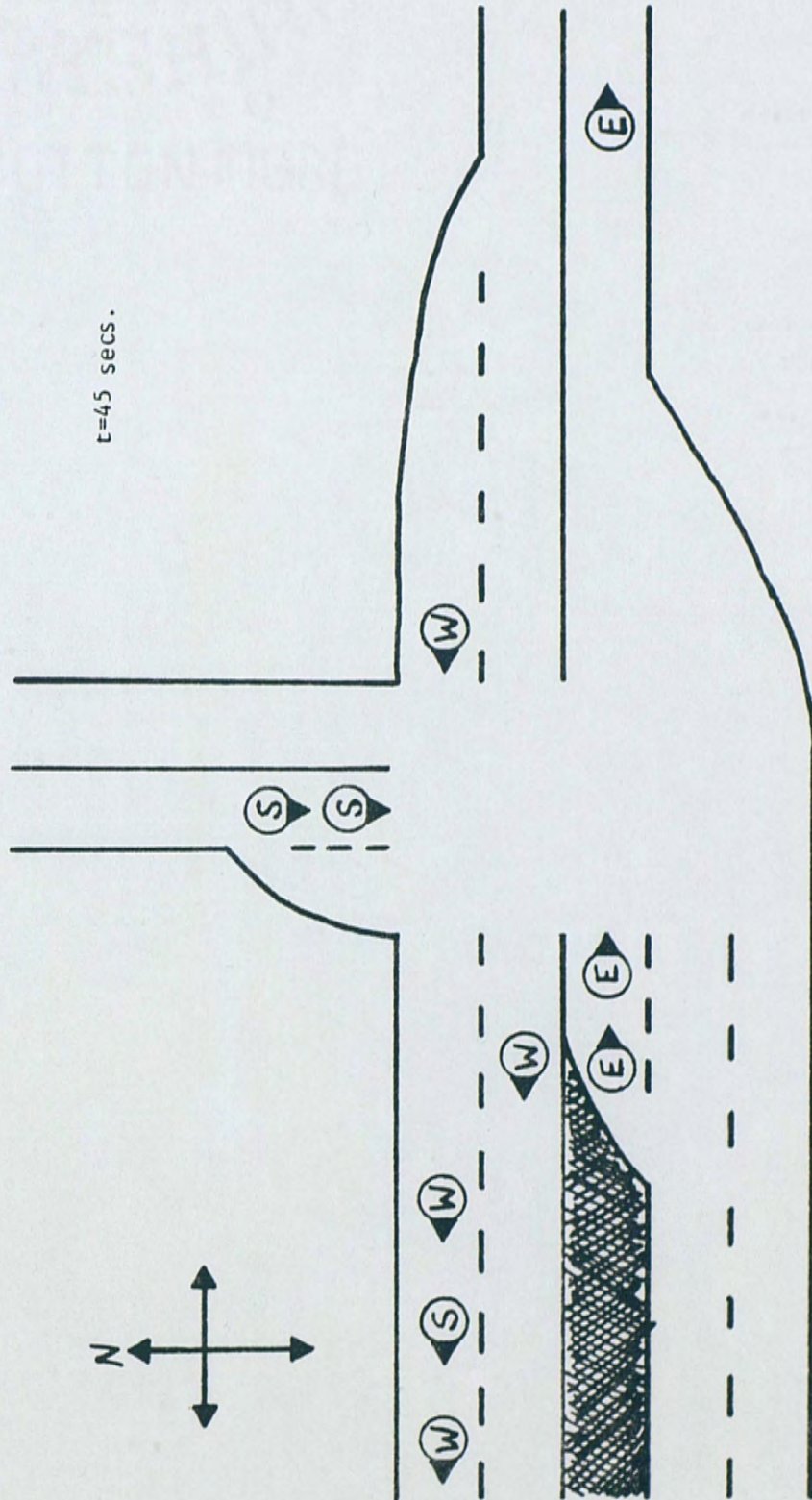

Figure 16. Time lapse of a deterministic simulation run

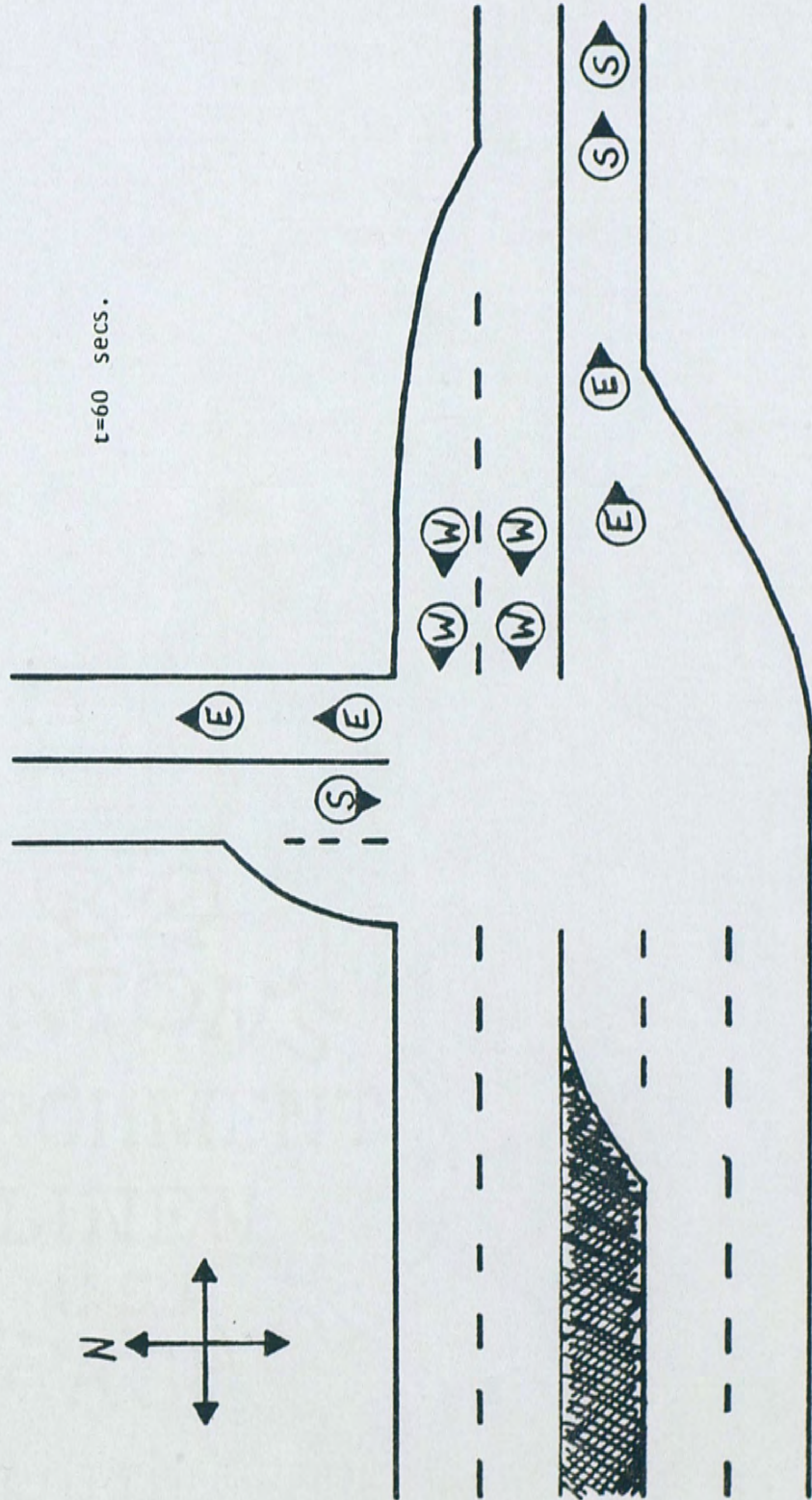

Figure 17. Time lapse of a deterministic simulation run

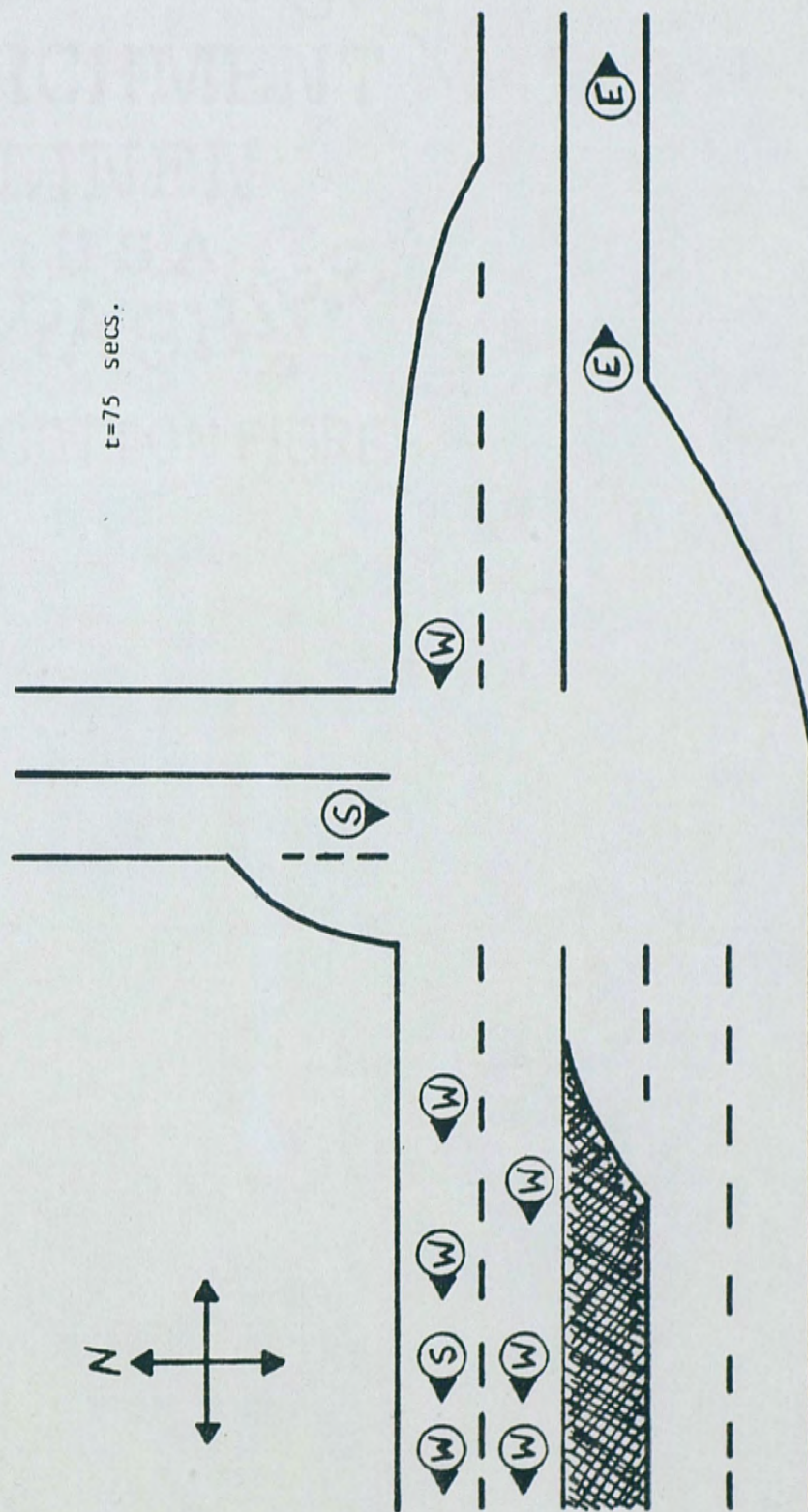

Figure 18. Time lapse of a deterministic simulation run

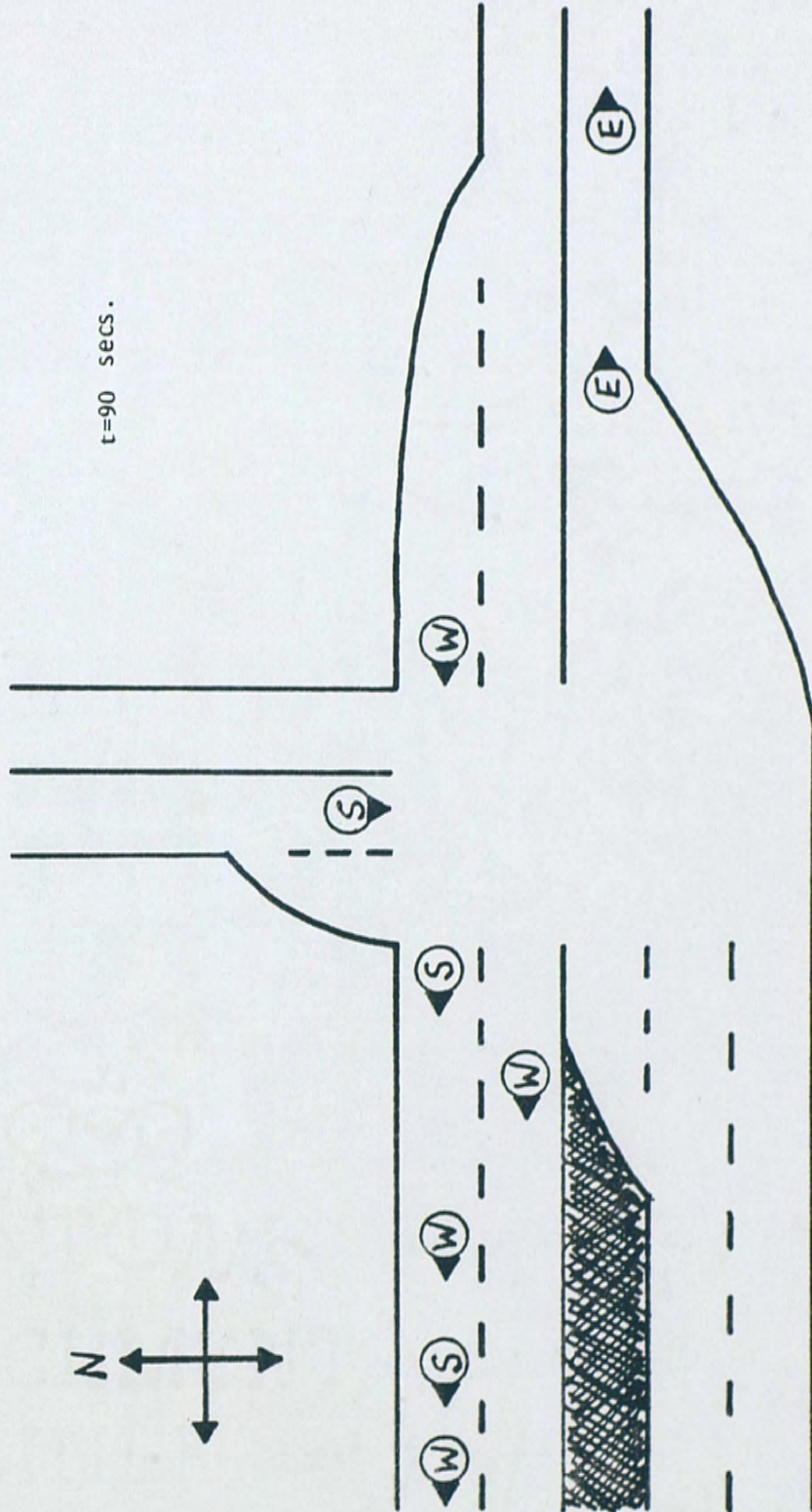

Figure 19. Time lapse of a deterministic simulation run

Figure 20 shows the manual calculations for the southbound, left-turning traffic. The corresponding simulation results are also given.

Figure 21 shows the manual calculations for the eastbound left-turning traffic, as well as, the corresponding simulation results.

The manual calculations are only for the first 100 seconds, whereas the computer simulation calculates statistics for 3600 seconds. Due to initial starting conditions, a bias causes small differences between the manual and computer calculations.

Analysis of Results

Choosing the best type of traffic signal control (pretimed, semi-actuated, full-actuated) is a complicated decision because each type gives varying performance, requires different control equipment and has different costs to operate and maintain. The proper choice of control type is further complicated if there is a need for left turn arrows.

Although traffic engineers recognize that each type of control has its appropriate use, selection of control type is generally determined without a comprehensive analysis because of the lack of guidelines and supporting reference data.⁽³⁾

For this project, the effectiveness of each traffic signal type was evaluated in terms of the average waiting time for use of the intersection for the three directions of traffic, the total number of vehicles to go through the intersection, the average queue length for all lanes of traffic, and an average of the maximum queue lengths for all lanes of traffic. These measures of effectiveness were chosen because they can be directly related to traffic flow at an individual intersection and because they concern traffic engineers, as well as drivers on the highway.

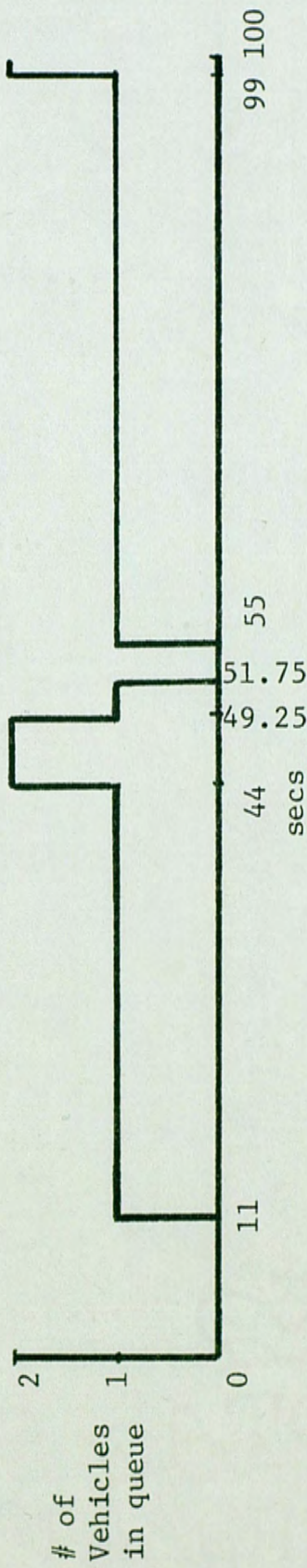

Avg. Wait time = $\frac{35.75 + 5.25 + 44 + 1}{4} = 21.5 \text{ secs/car}$

Predicted by simulation = 26.72 secs/car

Avg. Queue Length = $\frac{1(33. + 2.5 + 44) + 2(5.25 + 1)}{100} = .92 \text{ car}$

Predicted by simulation = 1.095 cars

Avg. Queue Util. = $\frac{2.5 + 2.5}{100} = .05$

Predicted by simulation = .1021

Figure 20. Verification for southbound left-turning traffic

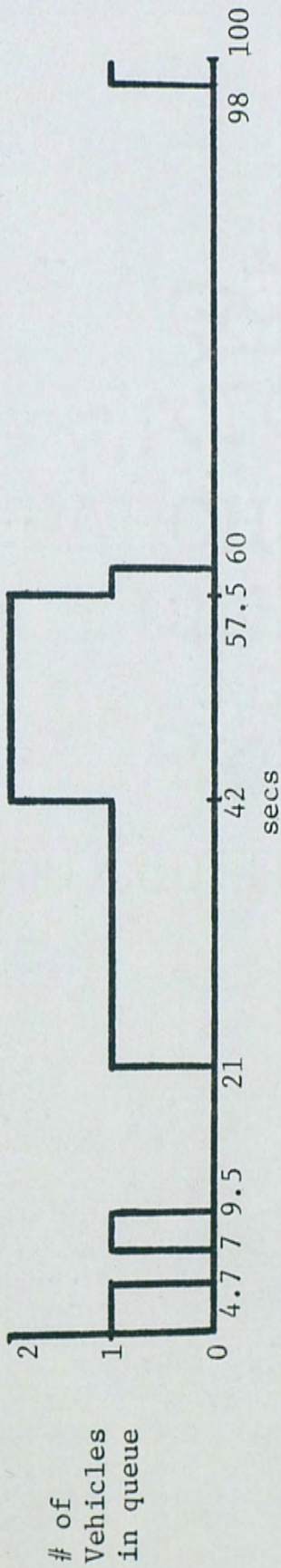

Avg. Wait Time = $\frac{2.2 + 0.0 + 34.0 + 15.5 + 2.0}{5} = 10.74$ secs/car

Predicted by simulation = 22.33 secs/car

Avg. Queue Length = $\frac{1(4.7 + 2.5 + 21.0 + 2.5 + 2.0) + 2(15.5)}{100} = .637$ car

Predicted by simulation = .6358 car

Avg. Queue Util. = $\frac{4.7 + 2.5 + 2.5 + 2.5}{100} = .122$

Predicted by simulation = .0747

Figure 21. Verification for eastbound left-turning traffic

See Figures 22-24 for a summary of the results.

Some general conclusions made from these results were:

1. The most effective pretimed signal was the one with the shorter cycle length with the longest green phase, e.g., the A.M. pretimed/exclusive left turn arrow signal with the shorter cycle length of 55 seconds and the longer green phase of 41.25 seconds has an average wait time of 10.66 seconds and an average queue length of .58 car as opposed to an average wait time of 12.03 seconds and an average queue length of .67 car for the longer cycle length of 60 seconds.

2. An exclusive left turn arrow with each of the three types of signal control not only increased the average wait time, but also caused longer queues. For the A.M. semi-actuated/exclusive left turn arrow signal, the maximum queue lengths for various phasings are 6.0 cars, 4.0 cars and 4.67 cars. The semi-actuated signal with no left turn arrow has maximum queue lengths of only 4.33, 3.0 and 3.88 cars for the various phasings. And the semi-actuated exclusive-permissive left turn arrow signal also has shorter maximum queue lengths.

3. A full-actuated signal was the most effective in reducing delay time and minimizing queue length. Figure 24 shows that the A.M. full-actuated/no left turn arrow signal with a cycle length of 60 seconds has an average wait time of 3.64 seconds and an average queue length of .20 car. Statistics for the comparable retimed signal are 7.33 seconds for average wait time and .42 car for average queue length.

PRETIMED AM									
	NO LEFT TURN			EXCLUSIVE LEFT TURN ARROW			EXCLUSIVE-PERMISSIVE LEFT TURN ARROW		
	SECONDS			SECONDS			SECONDS		
Green	41.25	39.	35.75	41.25	39.	35.75	41.25	42.25	35.75
Amber	5.5	6.	5.5	5.5	6.	5.5	5.5	6.5	5.5
Red	8.25	15.	13.75	8.25	15.	13.75	8.25	16.25	13.75
Cycle	55	60	55	55	60	55	55	65	55
Average Wait Time	6.64	7.33	6.12	10.66	12.03	10.95	8.16	9.37	7.75
Total # of Cars	1648	1599	1494	1644	1597	1644	1644	1600	1494
Average Queue Length	.37	.42	.31	.58	.67	.63	.47	.56	.54
Max. Queue Length	4.83	4.5	3.67	5.67	5.5	6.33	5.0	5.17	4.5
PRETIMED PM									
	NO LEFT TURN			EXCLUSIVE LEFT TURN ARROW			EXCLUSIVE-PERMISSIVE LEFT TURN ARROW		
	SECONDS			SECONDS			SECONDS		
Green	41.25	39.	35.75	41.25	39.	35.75	41.25	42.25	35.75
Amber	5.5	6.	5.5	5.5	6.	5.5	5.5	6.5	5.5
Red	8.25	15.	13.75	8.25	15.	13.75	8.25	16.25	13.75
Cycle	55	60	55	55	60	55	55	65	55
Average Wait Time	6.22	6.93	6.58	14.57	23.50	11.09	7.37	8.84	8.21
Total # of Cars	1791	1703	1600	1785	1774	1600	1791	1706	1600
Average Queue Length	.36	.46	.38	.96	1.64	.64	.42	.57	.46
Max. Queue Length	4.0	5.17	4.67	5.67	7.83	5.33	4.33	5.83	4.83

Figure 22. Summary of results for pretimed signal

SEMI-ACTUATED AM									
	NO LEFT TURN			EXCLUSIVE LEFT TURN ARROW			EXCLUSIVE-PERMISSIVE LEFT TURN ARROW		
	SECONDS			SECONDS			SECONDS		
Green	41.25	39.	35.75	42.25	39.	35.75	41.25	42.25	35.75
Amber	5.5	6.	5.5	6.5	6.	5.5	5.5	6.5	5.5
Red	8.25	15.	13.75	16.25	15.	13.75	8.25	16.25	13.75
Cycle	55	60	55	65	60	55	55	65	55
Average Wait Time	5.83	4.73	5.22	9.89	8.13	8.76	6.49	7.55	6.65
Total # of Cars	1642	1490	1601	1646	1487	1600	1492	1646	1601
Average Queue Length	.31	.22	.29	.52	.36	.46	.31	.42	.37
Max. Queue Length	4.33	3.0	3.88	6.0	4.0	4.67	3.88	5.33	4.33
SEMI-ACTUATED PM									
	NO LEFT TURN			EXCLUSIVE LEFT TURN ARROW			EXCLUSIVE-PERMISSIVE LEFT TURN ARROW		
	SECONDS			SECONDS			SECONDS		
Green	41.25	39.	35.75	42.25	39.	35.75	41.25	42.25	35.75
Amber	5.5	6.	5.5	6.5	6.	5.5	5.5	6.5	5.5
Red	8.25	15.	13.75	16.25	15.	13.75	8.25	16.25	13.75
Cycle	55	60	55	65	60	55	55	65	55
Average Wait Time	5.78	5.42	5.02	14.87	9.49	9.66	6.35	7.41	6.44
Total # of Cars	1788	1600	1708	1785	1600	1708	1600	1789	1708
Average Queue Length	.32	.25	.28	.70	.53	.52	.42	.70	.52
Max. Queue Length	4.17	4.0	3.67	6.33	4.67	5.33	4.33	5.0	3.88

Figure 23. Summary of results for semi-actuated signal

FULL-ACTUATED AM									
	NO LEFT TURN			EXCLUSIVE LEFT TURN ARROW			EXCLUSIVE-PERMISSIVE LEFT TURN ARROW		
	SECONDS			SECONDS			SECONDS		
Green	41.25	39.	35.75	42.25	39.	35.75	41.25	42.25	35.75
Amber	5.5	6.	5.5	6.5	6.	5.5	5.5	6.5	5.5
Red	8.25	15.	13.75	16.25	15.	13.75	8.25	16.25	13.75
Cycle	55	60	55	65	60	55	55	65	55
Average Wait Time	3.25	3.64	3.86	9.75	7.13	7.79	5.54	8.98	7.11
Total # of Cars	1494	1601	1645	1599	1492	1638	1492	1599	1638
Average Queue Length	.16	.20	.22	.54	.34	.44	.27	.52	.41
Max. Queue Length	3.0	3.17	4.33	5.0	3.5	5.0	3.17	4.67	5.0
FULL-ACTUATED PM									
	NO LEFT TURN			EXCLUSIVE LEFT TURN ARROW			EXCLUSIVE-PERMISSIVE LEFT TURN ARROW		
	SECONDS			SECONDS			SECONDS		
Green	41.25	39.	35.75	42.25	39.	35.75	41.25	42.25	35.75
Amber	5.5	6.	5.5	6.5	6.	5.5	5.5	6.5	5.5
Red	8.25	15.	13.75	16.25	15.	13.75	8.25	16.25	13.75
Cycle	55	60	55	65	60	55	55	65	55
Average Wait Time	3.43	3.63	3.59	7.42	7.09	7.27	5.20	5.87	5.81
Total # of Cars	1600	1708	1792	1708	1600	1789	1600	1708	1789
Average Queue Length	.21	.24	.26	.44	.38	.45	.26	.33	.33
Max. Queue Length	3.67	3.5	4.0	4.5	4.33	5.17	3.83	4.0	4.83

Figure 24. Summary of results for full-actuated signal

4. The volume of traffic on State Road 426 did not warrant a left turn arrow with any of the three types of signal to improve effectiveness, e.g., the A.M. full-actuated/no left turn arrow signal has average wait times of 3.25 seconds, 3.64 seconds and 3.86 seconds. Whereas with an exclusive left turn arrow the average wait times increase to 9.75, 7.13 and 7.79 seconds for the various phasings and with an exclusive-permissive left turn arrow the average wait times are also longer at 5.54, 8.98 and 7.11 seconds.

5. A poorly timed signal, whether pretimed, semi-actuated, or full-actuated, will cause long delay times and long queues.

Each type of traffic signal (pretimed, semi-actuated and full-actuated) with the various left turn arrow options was simulated for one hour "real time." Each simulation computed and printed out the data for three different signal phases, i.e., variable lengths of green, amber and red light. The simulation execution time for this was, on the average, 2.5 minutes, and the average CPU time was 13.0 seconds.

Areas for Further Research

This model is very basic, therefore there are several limitations. Referring to Figure 4, a southbound vehicle turning left on to State Road 426 takes use of the intersection for 2.5 seconds before freeing the resources for the next vehicle's use. In the real world, when one vehicle is part-way through the intersection, the next car would be starting through the intersection. To improve this simulation model, the RLSB resource should be freed-up immediately after the wait time is collected. The SBLTZ, WBSTZ, EBLTZ,

and EBSTZ should be freed-up as the vehicle passes through each collision area. This would require a little research to determine how the 2.5 seconds to clear the intersection would be distributed so that the SBLTZ resource would be freed-up after an activity of a certain duration, then the WBSTZ resource would be freed-up after a length of time, etc.

Referring to Figure 3, another limitation is noted. A vehicle on State Road 426 waiting to turn left onto Howell Branch Road will take use of the WBSTZ resource thus blocking that inside lane of westbound traffic until the outside lane is free (WBRTZ resource). Most drivers would wait until both westbound lanes were free before making the left turn. This situation can be modelled using SLAM II which allows blocking at an AWAIT node. Therefore, a vehicle at the EBLTZ node can be programmed to wait there until both the WBSTZ and WBRTZ resources are available.

This model assumes that all vehicles moving in the same direction pass through the intersection in the same length of time, e.g., all eastbound cars going straight through on State Road 426 clear the intersection in 2.2 seconds. Actually, the first vehicle in the queue waiting for a green light will take longer to clear the intersection than the next car, and that car will take a longer time than the third car. Further research must be done to find out reasonable clearance times and after how many cars the headway becomes constant.

One way of modelling this situation may be to assign an ATRIB value to the first car to take use of the intersection when the light turns green and to increment that ATRIB for each subsequent car.

When the light turns red, that ATRIB would have to be decremented to zero for reassignment to the first car in the next green phase. Thus the vehicle with the first ATRIB value will take the longest time to start up and pass through the intersection. As the ATRIB value increases, the time to clear the intersection decreases until that point where subsequent vehicles have a constant clearance time, i.e., when the ATRIB value reaches a maximum value.

Another way of modelling this may be to keep track of the number of entities that have entered the intersection since the light turned green, i.e., NNCNT (I). Thus, if NNCNT (I) is equal to zero, the activity will have the longest time length, if NNCNT (I) equals one, the time length will be shorter. When NNCNT (I) reaches a maximum number, the subsequent activities will have a constant duration. When the traffic signal turns red, NNCNT (I) must be decremented to zero.

According to Figure 4, a southbound vehicle turning right onto State Road 426 will make the turn if the SBRTZ resource is free, whether the light is red or green. If the westbound traffic has the right-of-way, it may be necessary for the southbound vehicle to check a further distance east for another car using the intersection, i.e., the SBLTZ, WBRTZ and WBOL resources must also be free in order for the southbound vehicle to make the right turn. In some instances, e.g., a high-speed highway, it may be necessary to check if a westbound vehicle is approaching the intersection, before making the right turn. This may require adding another zone to the model further east of the WBOL zone. The southbound vehicle should be

modelled to make the right turn only when the intersection is clear (the resources are free) and when there is no westbound vehicle about to enter the intersection (the added zone is free).

These are a few major areas for further research. When these have been incorporated into the model, undoubtedly, further enhancements will be found. After many corrections and amendments, simulation of traffic at a T - intersection using SLAM may have the potential to replace those package programs used by the Department of Transportation.

APPENDIX A

TABLE OF SLAM NOTATIONS

1. Global Variables

XX(1)	length of green light (in seconds) for east-west traffic
XX(2)	length of amber light (in seconds) for east-west traffic
XX(3)	length of red light (in seconds) for east-west traffic
XX(4)	length of left turn arrow (in seconds) for eastbound left-turn lane

2. Resources

WBRTZ	westbound, right-turn zone
WBSTZ	westbound, straight-through zone
EBLTZ	eastbound, left-turn zone
EBSTZ	eastbound, straight-through zone
SBRTZ	southbound, right-turn zone
SBLTZ	southbound, left-turn zone
WBOL	westbound, outside lane
WBIL	westbound, inside lane
GWBSTRT	green light for westbound, straight-through and/or right-turning lanes
GEBST	green light for eastbound, straight-through lane
GEBLT	green light for eastbound, left-turning lane
RLSB	red light for southbound traffic, right and left-turning lanes

3. Attributes for Vehicles

ATRI(1)	time the car enters a queue at the intersection
ATRI(2)=1	westbound car will continue straight through the intersection
ATRI(2)=2	westbound car will turn right at the intersection

APPENDIX B
CONVERSION TABLE

Research Report

Program Listing

WBRTZ

ZERT

WBSTZ

ZES

EBLTZ

ZWLT

EBSTZ

ZWS

SBRTZ

ZNRT

SBLTZ

ZNLT

WBOL

ZESR

WBIL

ZESC

GWBSTRT

GRNES

GEBST

GRNWS

GEBLT

GRNWLT

RLSB

RED

WST

ESA

WRT

ERT

EST

WSA

ELT

WLT

SRT

NRT

SLT

NLT

APPENDIX C

PROGRAM LISTING FOR TRAFFIC NETWORKS

```

1 GEN, K. M. ANDERSON, T INTERSECTION PM, 6/15/82, 3;
2 LIMITS, 13, 2, 500;
3 NETWORK;
4     RESOURCE/ZERT(1), 1/ZES(1), 2/ZWLT(1), 3/ZWS(1), 4;
5     RESOURCE/ZNRT(1), 9/ZNLT(1), 10/ZESR(1), 11/ZESC(1), 12;
6     RESOURCE/GRNES(0), 5/GRNWS(0), 6/GRNWLT(0), 7/RED(0), 8;
7 ;
8 ; TRAFFIC FROM WEST
9 ;
10     CREATE, EXPON(4.2), , 1, , 1;
11     ACT, , .75, WSA;
12     ACT, , .25, WLT;
13 WSA    AWAIT(6), GRNWS/1;
14     AWAIT(4), ZWS/1;
15     COLCT, INT(1), WAIT TIME WSA, , ;
16     ACT, 2.2;
17     FREE, GRNWS/1;
18     FREE, ZWS/1;
19     TERM;
20 WLT    AWAIT(7), GRNWLT/1;
21     AWAIT(3), ZWLT/1;
22     AWAIT(2), ZES/1;
23     AWAIT(1), ZERT/1;
24     COLCT, INT(1), WAIT TIME WLT, , ;
25     ACT, 2.5;
26     FREE, GRNWLT/1;
27     FREE, ZWLT/1;
28     FREE, ZES/1;
29     FREE, ZERT/1;
30     TERM;
31 ;
32 ; TRAFFIC FROM EAST
33 ;
34     CREATE, EXPON(5.9), , 1, , 1;
35     ACT, , .70, A1;
36     ACT, , .30, A2;
37 A1    ASSIGN, ATRIB(2)=1;      CAR GOING STRAIGHT
38     ACT, , , G1;
39 A2    ASSIGN, ATRIB(2)=2;      CAR TURNING RIGHT
40 G1    GOON, 1;
41     ACT, , ATRIB(2).EQ.2.OR.NNQ(11).LE.NNQ(12), ERT;
42     ACT, , , ESA;
43 ESA    AWAIT(12), ZESC/1;
44     AWAIT(5), GRNES/1;
45     AWAIT(2), ZES/1;
46     COLCT, INT(1), WAIT TIME ESA, , ;
47     ACT, 2.2;
48     FREE, ZESC/1;
49     FREE, GRNES/1;
50     FREE, ZES/1;
51     TERM;
52 ERT    AWAIT(11), ZESR/1, 1;
53     ACT, , ATRIB(2).EQ.1, RTS;
54     ACT, , ATRIB(2).EQ.2, RTR;

```



```

55 RTS      AWAIT(5), GRNES/1;
56          AWAIT(1), ZERT/1;
57          AWAIT(10), ZNLT/1;
58          AWAIT(9), ZNRT/1;
59          COLCT, INT(1), WAIT TIME ERTS, , ;
60          ACT, 2. 2;
61          FREE, ZESR/1;
62          FREE, GRNES/1;
63          FREE, ZERT/1;
64          FREE, ZNLT/1;
65          FREE, ZNRT/1;
66          TERM;
67 RTR      AWAIT(1), ZERT/1;
68          COLCT, INT(1), WAIT TIME ERT, , ;
69          ACT, 2. 2;
70          FREE, ZESR/1;
71          FREE, ZERT/1;
72          TERM;
73 ;
74 ; TRAFFIC FROM NORTH
75 ;
76          CREATE, EXPON(14. 1), , 1, , 1;
77          ACT, , . 50, NRT;
78          ACT, , . 50, NLT;
79 NRT      AWAIT(9), ZNRT/1;
80          COLCT, INT(1), WAIT TIME NRT, , ;
81          ACT, 2. 2;
82          FREE, ZNRT/1;
83          TERM;
84 NLT      AWAIT(8), RED/1;
85          AWAIT(10), ZNLT/1;
86          AWAIT(2), ZES/1;
87          AWAIT(3), ZWLT/1;
88          AWAIT(4), ZWS/1;
89          COLCT, INT(1), WAIT TIME NLT, , ;
90          ACT, 2. 5;
91          FREE, RED/1;
92          FREE, ZNLT/1;
93          FREE, ZES/1;
94          FREE, ZWLT/1;
95          FREE, ZWS/1;
96          TERM;

```

APPENDIX D

PROGRAM LISTING FOR TRAFFIC SIGNALS

```

99 ;TRAFFIC SIGNAL
100 ;PRETIMED
101 ;NO LEFT TURN ARROW
102 ;
103 CREATE,,,,,1;
104 CYCLE ALTER,GRNWS/1;
105 ALTER,GRNWLT/1;
106 ALTER,GRNES/2;
107 ACT,XX(1);
108 ALTER,GRNWS/-1;
109 ALTER,GRNWLT/-1;
110 ALTER,GRNES/-2;
111 ACT,XX(2);
112 ALTER,RED/1;
113 ACT,XX(3);
114 ALTER,RED/-1;
115 ACT,,,CYCLE;
116 END;

99 ;TRAFFIC SIGNAL
100 ;PRETIMED
101 ;EXCLUSIVE LEFT TURN ARROW
102 ;
103 CREATE,,,,,1;
104 CYCLE ALTER,GRNWS/1;
105 ALTER,GRNWLT/1;
106 ACT,XX(4);
107 ALTER,GRNWLT/-1;
108 ALTER,GRNES/2;
109 ACT,XX(1)-XX(4);
110 ALTER,GRNWS/-1;
111 ALTER,GRNES/-2;
112 ACT,XX(2);
113 ALTER,RED/1;
114 ACT,XX(3);
115 ALTER,RED/-1;
116 ACT,,,CYCLE;
117 END;

99 ;TRAFFIC SIGNAL
100 ;PRETIMED
101 ;PERMISSIVE LEFT TURN ARROW
102 ;
103 CREATE,,,,,1;
104 CYCLE ALTER,GRNWS/1;
105 ALTER,GRNWLT/1;
106 ACT,XX(4);
107 ALTER,GRNES/2;
108 ACT,XX(1)-XX(4);
109 ALTER,GRNWS/-1;
110 ALTER,GRNWLT/-1;
111 ALTER,GRNES/-2;
112 ACT,XX(2);
113 ALTER,RED/1;
114 ACT,XX(3);
115 ALTER,RED/-1;
116 ACT,,,CYCLE;
117 END;

```



```

98 ;TRAFFIC SIGNAL
99 ;SEMI-ACTUATED
100 ;NO LEFT TURN ARROW
101 ;
102 CREATE;
103 CYCLE ALTER,GRNWS/1;
104 ALTER,GRNWLT/1;
105 ALTER,GRNES/2;
106 ACT,XX(1);
107 SWI1 ALTER,GRNWS/-1;
108 ALTER,GRNWLT/-1;
109 ALTER,GRNES/-2;
110 ACT,XX(2);
111 ALTER,RED/1;
112 ASSIGN,ATRIB(1)=TNOW;
113 ACT,4.;
114 G2 GOON,1;
115 ACT,,NVQ(8).EQ.0.OR.TNOW.GE.ATRIB(1)+16.,SWI2;
116 ACT,4.,,G2;
117 SWI2 ALTER,RED/-1;
118 ACT,,CYCLE;
119 END;

```

```

98 ;TRAFFIC SIGNAL
99 ;SEMI-ACTUATED
100 ;EXCLUSIVE LEFT TURN ARROW
101 ;
102 CREATE;
103 CYCLE ALTER,GRNWS/1;
104 ALTER,GRNWLT/1;
105 ACT,XX(4);
106 ALTER,GRNWLT/-1;
107 ALTER,GRNES/2;
108 ACT,XX(1)-XX(4);
109 SWI1 ALTER,GRNWS/-1;
110 ALTER,GRNES/-2;
111 ACT,XX(2);
112 ALTER,RED/1;
113 ASSIGN,ATRIB(1)=TNOW;
114 ACT,4.;
115 G2 GOON,1;
116 ACT,,NVQ(8).EQ.0.OR.TNOW.GE.ATRIB(1)+16.,SWI2;
117 ACT,4.,,G2;
118 SWI2 ALTER,RED/-1;
119 ACT,,CYCLE;
120 END;

```

```

98 ;TRAFFIC SIGNAL
99 ;SEMI-ACTUATED
100 ;PERMISSIVE LEFT TURN ARROW
101 ;
102 CREATE;
103 CYCLE ALTER,GRNWS/1;
104 ALTER,GRNWLT/1;
105 ACT,XX(4);
106 ALTER,GRNES/2;
107 ACT,XX(1)-XX(4);
108 SWI1 ALTER,GRNWS/-1;
109 ALTER,GRNWLT/-1;
110 ALTER,GRNES/-2;
111 ACT,XX(2);
112 ALTER,RED/1;
113 ASSIGN,ATRIB(1)=TNOW;
114 ACT,4.;
115 G2 GOON,1;
116 ACT,,NVQ(8).EQ.0.OR.TNOW.GE.ATRIB(1)+16.,SWI2;
117 ACT,4.,,G2;
118 SWI2 ALTER,RED/-1;
119 ACT,,CYCLE;
120 END;

```



```

8 ;TRAFFIC SIGNAL
9 ;ACTUATED
0 ;NO LEFT TURN ARROW
1 ;
2 CREATE;
3 CYCLE ASSIGN, ATRIB(1)=TVOW;
4 ALTER, GRNWS/1;
5 ALTER, GRNWLT/1;
6 ALTER, GRNES/2;
7 ACT, 6.;
8 G2 GOON, 1;
9 ACT, , NNQ(8).GE.1.OR.TNOW.GE.ATRIB(1)+38., SWI1;
0 ACT, 4., , G2;
1 SWI1 ALTER, GRVWS/-1;
2 ALTER, GRNWLT/-1;
3 ALTER, GRNES/-2;
4 ACT, XX(2);
5 ALTER, RED/1;
6 ASSIGN, ATRIB(2)=TVOW;
7 ACT, 4.;
8 G3 GOON, 1;
9 ACT, , NVQ(5).GE.1.OR.NVQ(6).GE.1.OR.NNQ(7).GE.1, SWI2;
0 ACT, , TVOW.GE.ATRIB(2)+15., SWI2;
1 ACT, 4., , G3;
2 SWI2 ALTER, RED/-1;
3 ACT, , , CYCLE;
4 END;

```

```

8 ;TRAFFIC SIGNAL
9 ;ACTUATED
0 ;EXCLUSIVE LEFT TURN ARROW
1 ;
2 CREATE;
3 CYCLE ASSIGN, ATRIB(1)=TVOW;
4 ALTER, GRNWS/1;
5 ALTER, GRNWLT/1;
6 ACT, XX(4);
7 ALTER, GRNWLT/-1;
8 ALTER, GRNES/2;
9 ACT, 6.;
0 G2 GOON, 1;
1 ACT, , NNQ(8).GE.1.OR.TNOW.GE.ATRIB(1)+38., SWI1;
2 ACT, 4., , G2;
3 SWI1 ALTER, GRVWS/-1;
4 ALTER, GRNES/-2;
5 ACT, XX(2);
6 ALTER, RED/1;
7 ASSIGN, ATRIB(2)=TVOW;
8 ACT, 4.;
9 G3 GOON, 1;
0 ACT, , NVQ(5).GE.1.OR.NVQ(6).GE.1.OR.NNQ(7).GE.1, SWI2;
1 ACT, , TVOW.GE.ATRIB(2)+16., SWI2;
2 ACT, 4., , G3;
3 SWI2 ALTER, RED/-1;
4 ACT, , , CYCLE;
5 END;

```



```

8 ;TRAFFIC SIGNAL
9 ;ACTUATED
0 ;PERMISSIVE LEFT TURN ARROW
1 ;
2 CREATE;
3 CYCLE ASSIGN, ATRIB(1)=TVOW;
4 ALTER, GRNWS/1;
5 ALTER, GRNWLT/1;
6 ACT, XX(4);
7 ALTER, GRVES/2;
8 ACT, 6.;
9 G2 GOON, 1;
0 ACT, , NNQ(8).GE.1.OR.TVOW.GE.ATRIB(1)+38., SWI1;
1 ACT, 4., , G2;
2 SWI1 ALTER, GRVWS/-1;
3 ALTER, GRNWLT/-1;
4 ALTER, GRVES/-2;
5 ACT, XX(2);
6 ALTER, RED/1;
7 ASSIGN, ATRIB(2)=TVOW;
8 ACT, 4.;
9 G3 GOON, 1;
0 ACT, , NNQ(5).GE.1.OR.NNQ(6).GE.1.OR.NNQ(7).GE.1, SWI2;
1 ACT, , TVOW.GE.ATRIB(2)+15., SWI2;
2 ACT, 4., , G3;
3 SWI2 ALTER, RED/-1;
4 ACT, , , CYCLE;
5 END;

```

REFERENCES CITED

1. Organization for Economic Co-operation and Development. Area Traffic Control Systems. Paris: OECD Road Research Group, 1972.
2. Drew, Donald R. Traffic Flow Theory and Control. New York: McGraw-Hill, Inc., 1968.
3. Tarnoff, P.J., and Parsonson, P.S. Selecting Traffic Signal Control at Individual Intersections. Washington, D.C.: Transportation Research Board, 1981.

BIBLIOGRAPHY

- Baerwald, John E., ed. Transportation and Traffic Engineering Handbook. New Jersey: Prentice-Hall, Inc., 1976.
- Drew, Donald R. Traffic Flow Theory and Control. New York: McGraw-Hill, Inc., 1968.
- Gazis, Denos C. Traffic Science. New York: John Wiley & Sons, 1974.
- Gerlough, Daniel L., and Barnes, Frank C. Poisson and Other Distributions in Traffic. Connecticut: Eno Foundation for Transportation, 1971.
- Organization for Economic Co-operation and Development. Area Traffic Control Systems. Paris: OECD Road Research Group, 1972.
- Pritsker, A. Alan B., and Pegden, Claude Dennis. Introduction to Simulation and SLAM. New York: John Wiley & Sons, 1979.
- Tarnoff, P.M., and Parsonson, P.S. Selecting Traffic Signal Control at Individual Intersections. Washington, D.C.: Transportation Research Board, 1981.