



Energy Science and Technology
Vol. 3, No. 2, 2012, pp. 63-73
DOI:10.3968/j.est.1923847920120302.334

ISSN 1923-8460[PRINT]
ISSN 1923-8479[ONLINE]
www.cscanada.net
www.cscanada.org

A Pareto Front Approach to Bi-objective of Distillation Column Operation Using Genetic Algorithm

G. R. Salehi^{[a],*}; A. Salehi^[a]; B. Ghorbani^[a]; M. Amidpour^[a]; M. Maleki^[a]; F. Kimiaghali^[a]

^[a]Energy System Engineering Department, K.N.Toosi University of Technology, Tehran, Iran.

*Corresponding author.

Supported by IFCO (Iran Fuel Consumption Organization).

Received 5 March 2012; accepted 5 May 2012

Abstract

In this paper, an exergy analysis approach is proposed for optimal design of distillation column by using Genetic algorithm. First, the simulation of a distillation column is performed by using the shortcut results and irreversibility in each tray is obtained. The area beneath the exergy loss profile is used as Irreversibility Index for exergy criteria. Then, two targets optimization algorithm (SA, Simulated Annealing) is used to maximize recovery and minimize irreversibility index in a column by six different variables (Feed Condition, Reflux Rate, Number of theoretical stage, Feed Trays (Feed Splitting, three variables)). SA uses one objective function for the purpose or alters two targets optimization to one target optimization. Then, GA optimization algorithm is used for two targets optimization except Pareto set which is used instead of objective function; finally, the results are compared with SA results. Then, one pump-around is considered to obtain better results (OPT2). Irreversibility index criterion is compared with exergetic efficiency, constant and variable feed composition splitters are considered.

Key words: Exergy analysis; Irreversibility index; Genetic algorithm; Process optimization; Distillation column

Salehi, G. R., Salehi, A., Ghorbani, B., Amidpour, M., Maleki, M., & Kimiaghali, F. (2012). A Pareto Front Approach to Bi-objective of Distillation Column Operation Using Genetic Algorithm. *Energy Science and Technology*, 3(2), 63-73. Available from: URL: <http://www.cscanada.net/index.php/est/article/view/10.3968/j.est.1923847920120302.334> DOI: <http://dx.doi.org/10.3968/j.est.1923847920120302.334>

INTRODUCTION

Thermodynamic analysis is one of the most important tools to develop the efficiency of distillation processes. It is helpful to quantify the thermodynamic efficiency of the process and identify the poor efficiency regions. Thermodynamic targets can be defined for modification in the column based on poor efficiency regions.

Thermodynamic analyses are applied to reduce exergy loss, or equivalently, entropy generation in a distillation column. Entropy generation in distillation columns is produced from heat transfer with finite temperature driving force, mixing of non-equilibrium vapor and liquid, pressure drop across the column and entropy generation due to heat loss to the ambient from the column surface. Two different ways are introduced to analyze distillation column thermodynamically, exergy analysis and an approach based on the temperature vs. enthalpy (T-H) curve.

Exergy analysis is useful to understand energy efficient distillation processes^[1-4]. It is used in most of the processes especially in gas separation processes (or low temperature processes). Another usage of exergy analysis in distillation column is for thermal integration of a column with other operation units. In Exergy analysis, it is necessary to consider performance criteria parameters to compare different conditions. Exergetic efficiency is a very prominent parameter to define total exergy loss in a distillation column. Exergetic efficiency indicates significant information about the potential of the column for improvement. High exergetic efficiency doesn't guarantee very low exergy loss in the column. For example, the potential for a large mass flow heat exchanger improvement is low and it needs large investment, on the other hand, if a low exergetic efficiency and a low exergy loss happen in an operation system simultaneously, improvement is not worthwhile, but if exergetic efficiencies are not very high and exergy losses are significant, there is a great potential for improvement.

Energy saving potential for modifications can be addressed to use T-H curve. A T-H curve at MTC (minimum thermodynamic condition) for a binary mixture is defined as distillation conditions approach reversible operation (without any entropy generation) in a column^[5-11]. As discussed in detail by Bandyopadhyay et al^[8], it can be assumed that a column with infinite stages and side exchanger in every stage has been approached to a reversible operation without heat loss and pressure drop in the column. On the contrary, Franklin^[10] showed that it is impossible to find a reversible separation scheme for many practical multi-component separations. However, it is revealed using the pseudo-binary concept of light and heavy key can overcome the sharpness limitations of reversible multi-component distillation^[6-9, 11]. T-H curve of a distillation column was named grand composite curve (CGCC) by Dhole and Linhoff^[7] and the generating procedure was described. Bandyopadhyay^[9] used the concept of T-H curves and introduced IRS (invariant rectifying stripping) curves for a distillation column. The IRS curves are used to set targets (proper feed preconditioning, feed location, and etc.) and optimization of a distillation column^[9, 11].

A distillation column can be analyzed from reversibility overview, using exergy loss profile. Exergy loss profile indicates irreversibilities in each distillation column stage. Dhole and Linhoff^[7], Zemp et al^[12], Atkinson^[1] showed acceptable targets to improve the process and remove irreversibilities. Chang and Li^[13], Santana and Zemp^[14] used the concept and tried to find a minor modification in distillation column. Later, Faria and Zemp^[15] used exergy loss and enthalpy-temperature profiles to calculate thermodynamic efficiency in distillation column. Entropy generation is produced by irreversibility rate in each stage of a distillation column. De Koeijer and Rivero^[16] used the concept (theory of irreversible thermodynamics, de Koeijer and Kjelstrup^[17]) on both adiabatic and diabatic experimental water/ethanol rectifying column. Rivero et al.^[14] carried out a detailed exergy analysis of a tertiary amyl methyl ether (TAME) unit of a crude oil refinery.

Column optimization is implemented in distillation column with considering different optimization targets, such as feed preheating, precooling (Dhole and Linhoff^[7]), feed splitting (Wankat and Kessler^[18] Agrawal and Herron^[4], Bandyopadhyay^[19, 20]), feed trays, reflux ratio and adding side condensers/re-boilers. Different exergy losses in a distillation column on energy-utilization diagrams are presented by Taprap and Ishida^[3]. Energy transformation and exergy loss of individual process steps are identified using the diagrams. It is shown by Ratkje

et al^[2] if driving force distributes uniformly in a column, entropy generation is at minimum. Thermodynamic efficiency is quantified in a distillation column to separate binary mixtures by Agrawal and Herron^[4]. They focused on the effect of feed conditions on a thermodynamic efficiency of distillation columns, but they worked only on binary and ideal mixture (constant relative volatility). Douani et al.^[21] tried to study exergy loss profile for improving the performance of distillation column. The results showed a non-uniform irreversibility distribution in columns especially in condensers, re-boilers and feed trays. Le Goff et al.^[22] studied distillation processes exergy analysis for high exergy losses in distillation operations, a new type of distillation (diabatic column) was proposed in which, Heat exchanging through each stage of the distillation column was manipulated instead of condensers and re-boilers on top and bottom of a distillation column. Jimenez, Salamon, Rivero^[23] and Le Goff et al.^[22] compared diabatic and adiabatic distillation columns and showed that using diabatic columns would cause a great reduction in entropy production. There are several studies on diabatic columns; Kjelstrup and Rosjorde^[24], Rivero^[25], Sauar et al.^[26], Schaller et al.^[27], Huang et al.^[28] revealed that diabatic columns are more efficient than adiabatic column due to lower capital cost and energy consumption for heating, cooling and etc.

According to the mentioned research, there are many works related to exergy analysis in distillation columns. However, there are some gaps too. Most of the studies used exergetic efficiency method (Khoa^[22]) and did not consider the tray irreversibility, others Like Linhoff^[7] and Zemp^[12] considered irreversibility in each stage, optimized the column with one or two degree of freedom (preheating, precooling, splitting (feed stage location) and etc.) and did not mention recovery precisely. Other works in diabatic columns (Le Goff^[22]) are not easily applicable in industry.

The purpose of this paper is to find the optimal condition of distillation columns with six degrees of freedom (Feed Condition, Reflux Ratio, Number of theoretical stage, Feed trays (three variables)), and in the next step considering pump-around with the six variables. There are two different approaches. First method is two targets optimization (Simulated Annealing) which is used to maximize recovery and minimize irreversibility index with one objective function. Second method is two targets optimization (GA Algorithm) which is used to maximize recovery and minimize irreversibility index using Pareto sets. In the end, the results are compared.

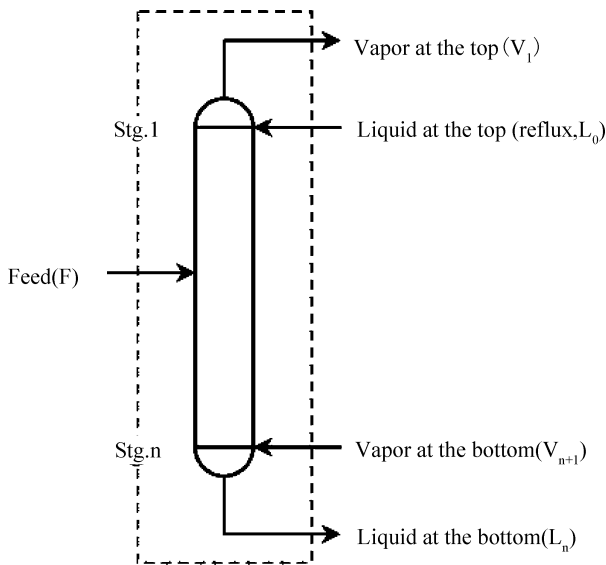

Figure 1
Simple Distillation Column

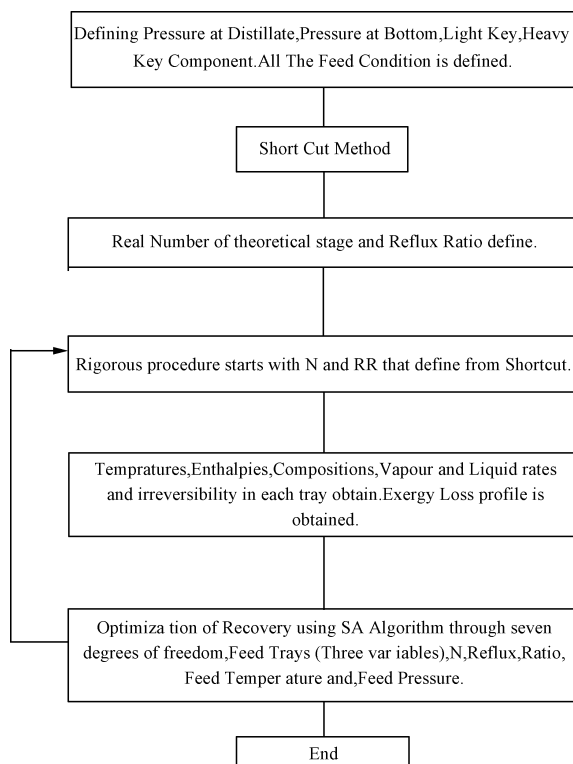

Figure 2
Calculation Procedure for Optimizing and Simulating a Simple Distillation Column

1. CALCULATION PROCEDURE

The procedure to optimize a single column is well known. In this article, estimated reflux ratio and theoretical stages are determined using Shortcut Method (Fenske-

Underwood-Gilliland, Then, column is solved rigorously using Bubble Point method to find temperature, enthalpy, and entropy in each stage, Goy-Stodolla relation is used to obtain irreversibility and exergy loss profile in each stage. Simulation code is written in three steps (Figure 2):

1.1 Shortcut Method

Shortcut method is widely used to solve a distillation column. One of the famous shortcut methods is FUG (Fenske - Underwood - Gilliland) and, it is divided in three parts:

Fenske Equation: in this equation, minimum number of theoretical stage is defined.

$$N_{\min} = \frac{\log\left(\frac{x_{(i,N+1)}}{x_{(i,1)}} \frac{x_{(j,1)}}{x_{(j,N+1)}}\right)}{\log(\alpha_{i,j})} \quad (1)$$

Underwood Equation: in this equation, minimum reflux rate is shown in the column. According to Seader [30], two different classes are defined to minimize reflux rate. The feed is a multi-component mixture in this article, in turn, separation class is two and the minimum reflux equation for class 2 separation is:

$$\sum \frac{\alpha_{i,r} z_{i,F}}{\alpha_{i,r} - \theta} = 1 - q \quad (2)$$

Gilliland Correlation: in this part, from a graphical curves (or Molokanov equation), real number of Theoretical stage and reflux rate is obtained. The results of shortcut method is the initial point for rigorous method.

1.2 Rigorous Method

According to Seader^[30], a rigorous method is applied to find tearing variables in each stage of distillation column, assuming specified pressure in each stage. Two specifications are needed; reflux ratio and distillate rate (both of them are initialized from shortcut method). Rigorous method is used to solve MESH equations to accomplish temperature, flow rate, enthalpy, entropy and distribution of components in each tray.

There are many methods to solve MESH equations. The simulation code is used in Gas Separation processes and most of the components have narrow range of vapor-liquid equilibrium ratios (K-Value). Thus BP Method is recommended. This procedure was suggested by Friday and Smith^[31] and developed in detail by Wang and Henke^[32]. Rigorous procedure using BP method is showed in Figure 3. It is referred to bubble point method, because in each iteration, a new set of stage temperatures is gained from bubble-point equations.

1.3 Exergy Loss Analysis

The exergy balance is similar to an energy balance but has the fundamental differences. The energy balance is a statement of the conservation of energy law, the exergy balance is a statement of the law of energy degradation. A useful concept for this purpose in exergy analysis is

Irreversibility. Goy-Stodolla Irreversibility relation is:

$$I = T_o S' \tag{3}$$

S' is an entropy generation in a process and T_o is environment temperature. For a control region:

$$\dot{I} = T_o \left[\sum m_e S_e - \sum m_i S_i - \sum \frac{Q_r}{T_r} \right] \tag{4}$$

Temperature, pressure, and composition are known in each tray, by assuming each tray as a control region, Irreversibility can be gained in each tray. Irreversibility Index is the area beneath the exergy loss profile.

Specify: all F_j, Z_{ij} , feed conditions (T_{Fj}, P_{Fj} , or h_{Fj}).

p_j, U_j, W_j ; all Q_j except Q_1 and Q_N ;

$N; L_j$ (reflux rate), V_0 (vapor distillate rate)

Set $k=1$ (to begin first iteration)

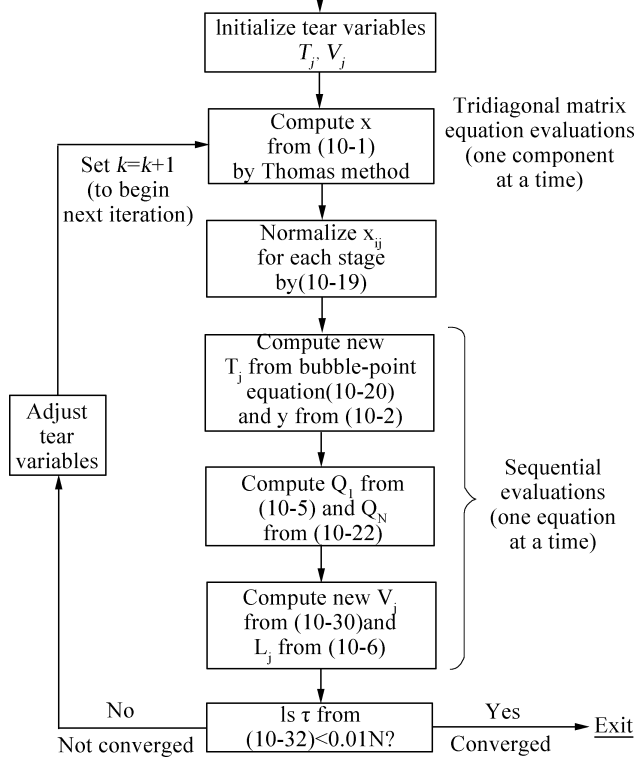

Figure 3
Algorithm for Wang-Henke BP Method for Distillation

1.4 Pump-Around Circuit

A pump-around circuit is a way that withdraws liquid from a tray, cools it, and then sends it back to upper tray. The original purpose for adding a pump-around is to reduce vapor and liquid traffic at the top section of the column. Without pump-around circuits, all condensation heat must be removed from the condenser, which causes in a large vapor flow rate at top trays. It is well known that heat shifting reduces separation efficiency and decreases the number of effective ideal trays.

Sharma et al.^[33] proposed a method to obtain the maximum pump-around heat removal. The heat removal

in the upper part of the column is gained using a heat balance. The upper part starts from an arbitrary tray and ends with the condenser. Next, the upper part is extended tray by tray, and heat surplus is obtained for each tray. The resultant heat surplus data are used to construct a column grand composite curve. Finally, maximum heat removal for each section is determined using the column grand composite curve. In this article, grand composite curve is constructed and tried to find the best location for pump-around based on reducing Irreversibility Index in the distillation column.

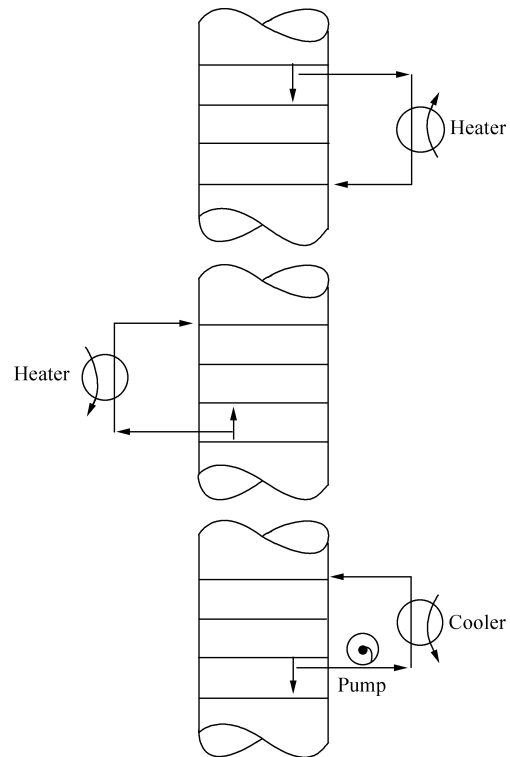

Figure 4
Pump-Around

1.5 GA Algorithm

A genetic algorithm (GA) is a search heuristic, mimics the process of natural evolution. In this article, GA Algorithm is used for Two Targets optimization with two different approaches. In the First approach (Section 2.3.1) a two targets algorithm is used and in the second approach, two targets optimization are merged in one target algorithm and it is optimized (Section 2.3.2).

1.5.1 Two Targets Optimization Using GA Algorithm

Step1. Producing initial generation (pool) stochastically.
Step2. Choosing from population of pool to produce children.

Step3. Using crossover and mutation function over selected population from Step2 and producing new children and adding them to the pool.

Step4. Calculating objective function value for all the existing population in the pool.

Step5. Choosing Dominant answers and updating Pareto set.

Step6. Allocating 25% of new pool with best answers of current pool based on recovery overview.

Step7. Allocating 25% of new pool with best answers of current pool based on irreversibility index overview.

Step8. Completing the new pool with the rest of the answers from current pool.

Step9. If Stop condition is valid, going to Step10,

Otherwise, going back to Step2.

Step10. Stop and exhibit the Pareto set.

Stop condition: 100 times implementation of Algorithm.

Initial population of the pool: 100.

1.5.2 Crossover Function

Use this function to search in a vast region of answer region (Diversification). First a stochastic point is chosen on current answer, switched into two matrixes. Therefore, from two parent matrixes, two children matrixes are produced.

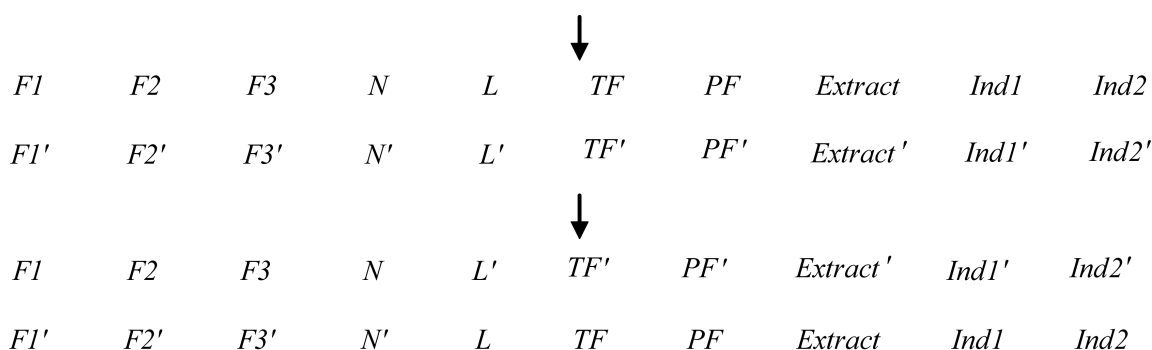

After producing children matrixes, if matrix arrays are not compatible with the problem circumstances, they are changed to have a correct child.

1.5.3 Mutation Function

First, some arrays from current answer are chosen, multiplied by β . β is a floating number between 0.8 and 1.2.

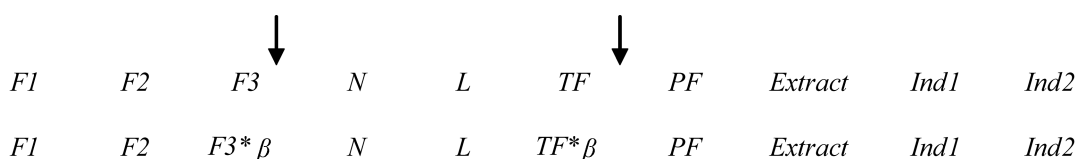

It is possible that some answers are depended on each other. After producing children matrixes, if matrix arrays is not compatible with the problem circumstances, change them to have a correct child.

3. CASE STUDY: DE-ETHANIZER

3.1 Validation with HYSYS

Feed information is shown in Table1. MATLAB and Aspen HYSYS 2006^[34] are used to simulate de-ethanizer column.

Table 1
Feed Data

Names	Data
C2 Composition	0.25
C3 Composition	0.25
i-C4 Composition	0.25
n-C4 Composition	0.25
TF (°C)	50
PF (Kpa)	2500
Molar Flow (Kgmol/h)	50

Application is started with a shortcut method and the Results are used as an initial point for rigorous calculation (BP- Method). Temperature, Enthalpy, Flow rate and Liquid Composition profile are obtained from shortcut results in Figure 5 and Figure 6.

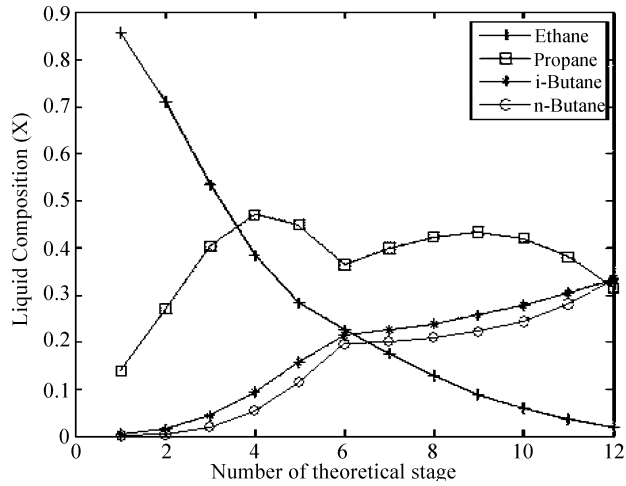

(b) Vapor and Liquid Profile

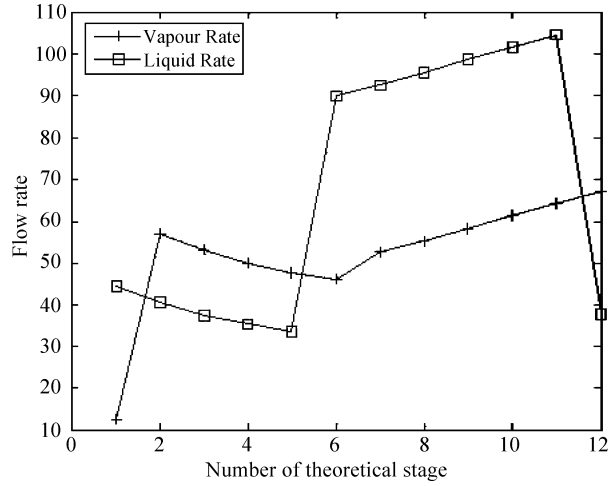

(a) Composition in Liquid Phase at Each Stage

Figure 5
Distillation Column Profiles from the Shortcut Results

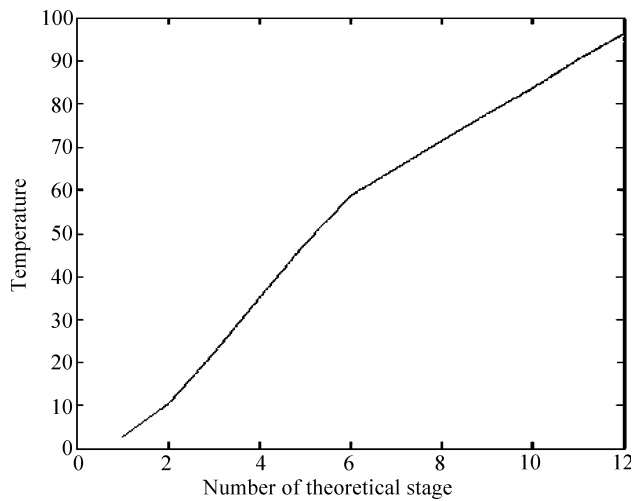

(a) Temperature Profile

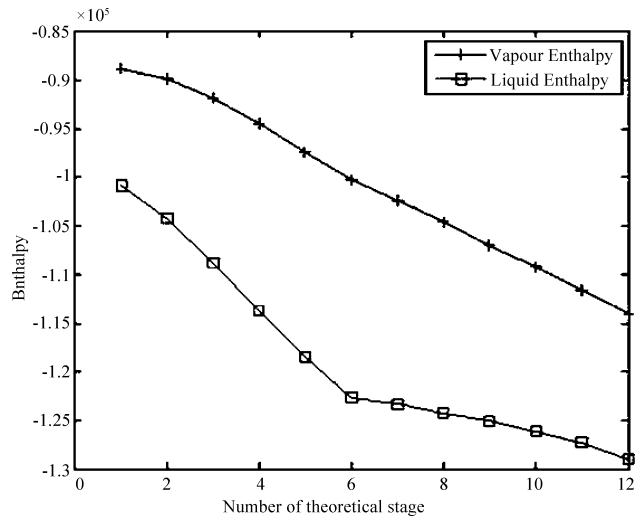

(b) Vapor/Liquid Enthalpy Profile

Figure 6
Distillation Column Profiles from the Shortcut Results

Figure 7 indicates, the most important irreversibilities in the condenser, re-boiler and Feed Tray (Douani et al.^[10]). Irreversibility Index is evaluated to compare different states in the optimization. The results of the procedure are shown in Table 2.

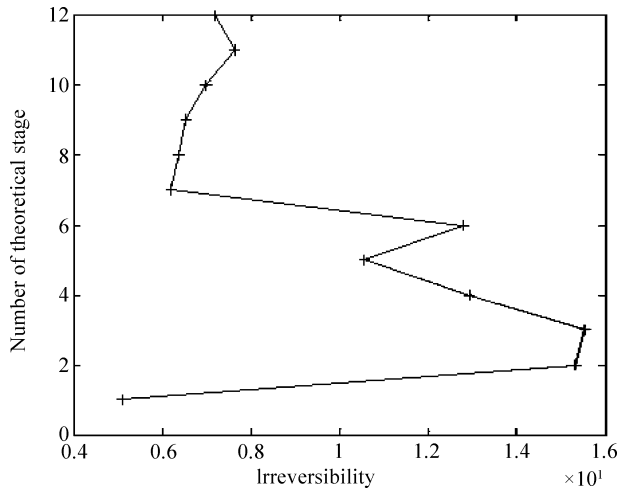

Figure 7
Exergy Loss Profile in Distillation Column

Table 2
Initial Point of Simulated Annealing Algorithm from Shortcut Method

Names	Data
Number Of Stage	12
Feed Tray Number	6
Reflux Rate (<i>Kgmol/h</i>)	44.4
Condenser duty (<i>KJ/h</i>)	4.6833e5
Reboiler duty (<i>KJ/h</i>)	-8.2117e5
Irreversibility index	1.07e5
Recovery of ethane	0.9466

In all optimizations, Distillate rate is assumed 12.51 kgmole/hr, however, in this article recovery and purity are defined.

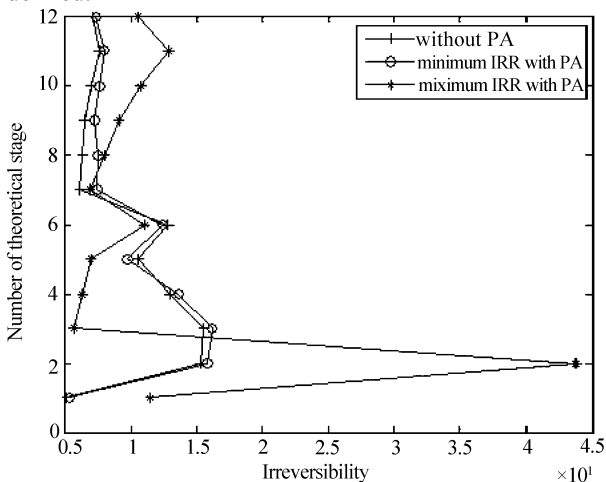

Figure 8
Comparing Exergy Loss Profile with and Without Pump-Around

3.2 Effect of Pump-Around

After solving distillation column rigorously and finding temperatures, entropies, enthalpies, vapor and liquid rates in each tray, the pump-around is considered in the case study. The following assumptions are regarded; it is permitted to use one pump-around in distillation column. In pump-around, liquid is extracted from a tray (15% of the tray liquid), cooled until the temperature reaches 10% lower than tray temperature. Sharma^[33] Method defines, there are 24 different positions for pump-around (12 trays including condenser and re-boiler). In Figure 9, the effect of different positions of pump-around on recovery and Irreversibility Index are represented. In Figure 8 Exergy Loss profile for three different conditions (without pump-around, with pump-around at the greatest irreversibility index and, with pump-around at the lowest irreversibility index) are shown. The greatest Irreversibility Index happens when liquid is extracted from tray number 11, and is sent back to tray 2. The lowest Irreversibility Index happens when liquid is extracted from tray 6 and is entered tray 5. Two different approaches are important; the maximum ethane recovery and the minimum Irreversibility Index. Therefore, there are two different types of results in this section (Table 3). The first array in the pump-around position is the tray that liquid is extracted and the second array is the tray that liquid is send back. In the best condition, Irreversibility Index increases 4.5% in comparison to the column without pump-around and recovery decreases 7% in comparison to the column without pump-around. The results indicate using pump-around is not reasonable based on irreversibility and recovery overview.

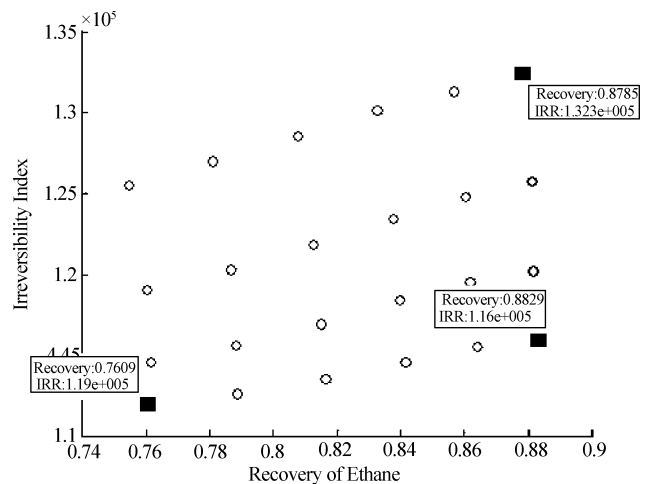

Figure 9
Irreversibility Index vs. Recovery in 24 Different Position of Pump-Around

Table 3
Distillation Column with One Pump-Around Using Shortcut Results

Names	Pump-Around position	Recovery	Irreversibility index
Best Irreversibility index	[6 5]	0.7609	1.119e5
Best recovery	[11 5]	0.8829	1.16e5
Without pump-around	[- -]	0.94	1.07e5

3.3 Two Targets Optimization-with Feed Splitting and Without Pump-Around

3.3.1 Constant Feed Composition (OPT1.Using SA Algorithm, Objective Function)

In the first part of optimization, there are five degrees of freedom, Numbers of theoretical stage, Reflux Rate, Feed Trays (Feed Splitting, three variables), Feed Condition. On the other hand, single, double and triple feed are considered in column optimization, but there is not a pump-around in this section. Composition in feed splitting is constant.

There are two approaches in two targets optimization, Pareto set and one objective function. In this part, objective function is used; on the other hand, two targets optimization is converted to one target optimization using

objective function. Simulated Annealing algorithm is used to maximize objective function. Objective function is:

$$OF = a * \left(\frac{Recov}{RB-1} \right) + \left(\frac{IRRB}{IRR-1} \right) * \frac{Recov}{b} \tag{5}$$

In this paper thermodynamic optimization criterion is based on Irreversibility index, however in some papers exergetic efficiency (Rational efficiency concept based on KOTAS) are used as criterion. The results (obtained from SA optimization algorithm) are shown in Figure 10. In Table. 4, final results (maximum OF) are shown in first row. EF is increased 24%, IRR is reduced 28%, and recovery is 99.3%. In the second row, Lowest IRR is found during the search for maximum OF (is reduced 35%) but recovery and EF is not suitable in comparison to first row. It is shown that EF and IRR are almost related.

Table 4
Results from OPT1, a=4, b=2

Names	OF	Recovery	Irreversibility Index	Exergy Efficiency
OPT1, Maximum OF	0.43	99.3%	6.55e4	57.4%
OPT1, Lowest IRR	0.13	91.3%	5.94e4	51.2%
Initial point	0	93.9%	9.16e4	46%

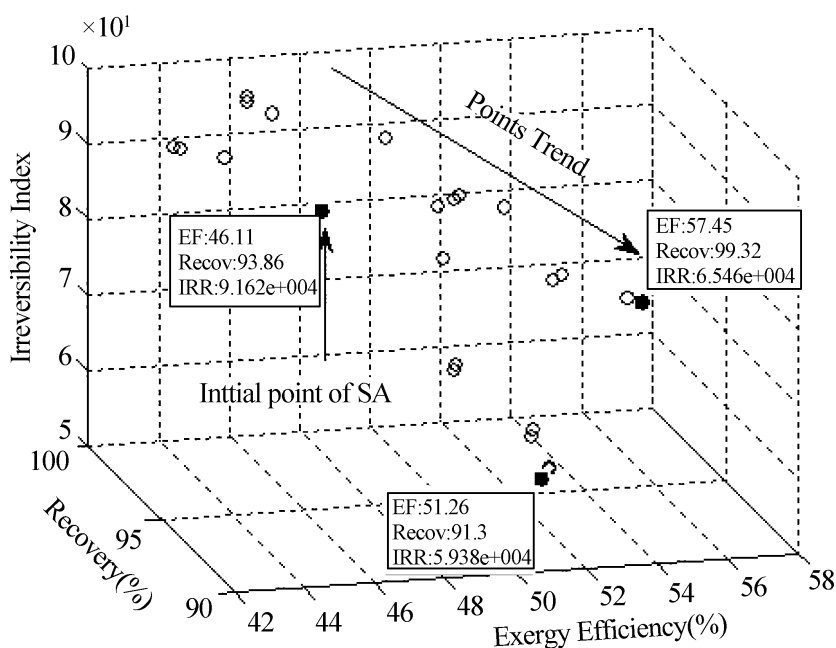

Figure 10
Results from SA Algorithm

3.2.2 Variant Feed Composition (OPT2. Using SA Algorithm, Objective Function)

This section is the same as section 3.2 but the feed composition is variable. The mixture is changed into two phases, sent liquid phase to rectifying section and gas

phase into stripping section of column. The results are shown in Table 5.

As it is shown in Table. 5, optimization algorithm determines the feed to be liquid or nearly close to liquid phase.

Table 5
Results from OPT2, a=4, b=2

Names	Vapor fraction	N	Feed Tray	OF	Recovery	Irreversibility Index	Exergy Efficiency
OPT1, Maximum OF		25	10,11	0.36	97.1%	6.08e4	52.7%
OPT1, Lowest IRR	0	24	9	0.33	92.1%	4.7e4	58%
Initial point	0	12	6	0	93.9%	9.16e4	46%

3.2.3 Constant Feed Composition (OPT3. Using GA Algorithm, Pareto Set)

This section is the same as section 3.2.1 but GA algorithm is used instead of SA algorithm and Pareto set is used instead of equations in 3.2.1 and 3.2.2.

Irreversibility index is reduced 6.7% (EF is increased 14.7%) and recovery reached to 99% in Maximum recovery state. In the Minimum IRR, recovery 1.1% and Irreversibility index is reduced 38.31% (EF is increased 30%).

Table 6
Results from OPT3, a=4, b=2

Names	Recovery	Irreversibility Index	Exergy Efficiency
Maximum Recovery	99%	8.54e4	52.8%
Minimum IRR	95%	5.65e4	59.8%
Initial point	93.9%	9.16e4	46%

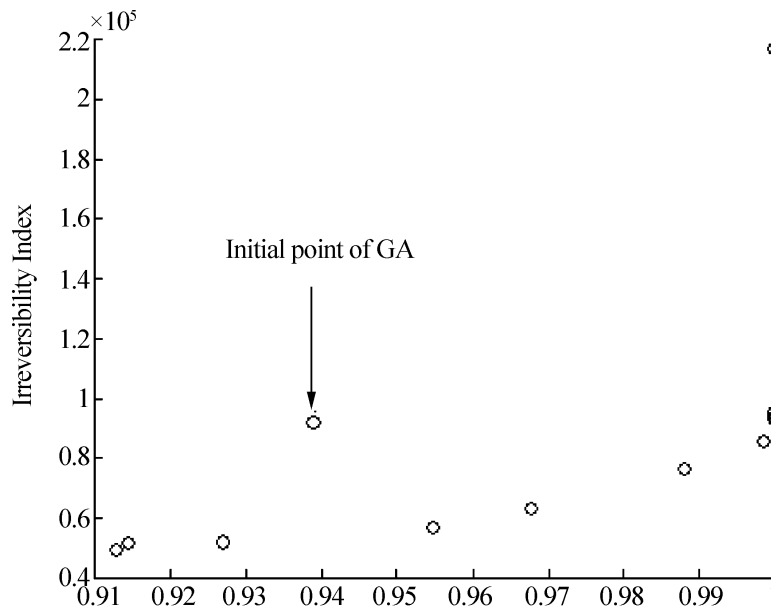

Figure 11
Results from GA Algorithm

3.3 Two Targets Optimization-with Feed Splitting and Pump-Around

It is assumed that heat removal duty is 178,000 kJ/kgmol and it is used to cool the liquid coming from a tray and sending back to column.

In this section, Algorithm in 3.2.1 is used for optimization but pump-around circuit is considered. In pump-around circuit heat removal duty is considered constant (QP= 178,800 KJ/h) and it is used to cool the extracting liquid from source tray to send it back to destination tray. The results are shown in Table 7.

3.3.1 OPT4. Using SA Algorithm, Objective Function

Table 7
Results from OPT4, a=4, b=2

Names	OF	Recovery	Irreversibility Index
OPT1, Maximum OF	0.198	96.99%	1.13e5
OPT1, Lowest IRR	0.08	90.14%	1.04e5
Initial point	0	88.09%	1.12e5

It is shown that using pump-around reduces recovery and increases Irreversibility index in comparison to previous section, in turn, using pump-around is not reasonable.

3.3.2 OPT5. Using GA Algorithm, Pareto Set

In this section, Algorithm in 3.2.3 is used for optimization and pump-around circuit is considered. In pump-around circuit, heat removal duty is considered constant (QP= 178,800 KJ/h) and it is used to cool the extracting liquid from source tray to send it back to destination tray. The results are shown in Table 8.

Table 8
Results from OPT5, a=4, b=2

Names	Recovery	Irreversibility Index
Maximum Recovery	99%	1.22e5
Minimum IRR	95%	1.2e5
Initial point	88.09%	1.12e5

It is shown that using pump-around does not reduce IRR if recovery increases.

CONCLUSION

In general, Irreversibility in distillation column trays depends on feed conditions, recovery of desired components in distillation, Number of theoretical stage, feed trays and reflux rate. There are two important issues in a distillation column; increasing recovery of desired components, main goal and also, reducing the irreversibilities in the process.

The method in this article has been improved previous studies in two ways. First, distillation column is solved rigorously; Irreversibility Index in each tray is evaluated. Second, degrees of freedom are five including Feed Trays (Feed Splitting, three variables), Feed Condition, Reflux Rate, and Number of theoretical stage in optimization and besides, one pump-around is considered separately and altogether with those five degrees of freedom. Moreover, Irreversibility index is compared with rational (exergetic) efficiency and it is shown, they are almost related.

The results show, when recovery is desired using pump-around is not reasonable from Irreversibility Index point of view but, without pump-around, recovery is maximized and Irreversibility Index is reduced simultaneously in comparison to the shortcut results.

ACKNOWLEDGMENT

We wish to thank the IFCO (Iran Fuel Consumption Organization) for their support of the research.

REFERENCES

- [1] Benali, T., Tondeur, D., & Jaubert, J.N. (2012). An Improved Crude Oil Atmospheric Distillation Process for Energy Integration: Part I: Energy and Exergy Analyses of the Process when a Flash is Installed in the Preheating Train. *Applied Thermal Engineering*, 32, 125-131.
- [2] Ratkje, S.K., Sauar, E., Hansen, E.M. Lien, K.M., & Hafskjold., B. (1995). Analysis of Entropy Production Rates for Design of Distillation Columns. *Ind. Eng. Chem. Res.*, 34(9), 3001-3007.
- [3] Taprap, R., & Ishida, M. (1996). Graphic exergy analysis of processes in distillation column by energy-utilization diagram. *AIChE J.*, 42(6), 1633-1641.
- [4] Agrawal, R., & Herron, D.M. (1997). Optimal Thermodynamic Feed Conditions for Distillation of Ideal Binary Mixtures. *AIChE J.*, 43(11), 2984-2996.
- [5] Khoa, T.D., Shuhaimi, M., & Nam, H.M. (2012). Application of Three Dimensional Exergy Analysis Curves for Absorption Columns. *Energy*, 37(1), 273-280.
- [6] Rizk, J., Nemer, M., & Clodic, D. (2012). A Real Column Design Exergy Optimization of a Cryogenic Air Separation Unit. *Energy*, 37(1), 417-429.
- [7] Dhole, V.R., & Linnhoff, B. (1993). Distillation Column Targets. *Comp. Chem. Eng.*, 17(5/6), 549-560.
- [8] Bandyopadhyay, S., Malik, R.K., & Shenoy, U.V. (1998). Temperature-Enthalpy Curve for Energy Targeting of Distillation Columns. *Comp. Chem. Eng.*, 22(12), 1733-1744.
- [9] Bandyopadhyay S., Malik, R.K., & Shenoy, U.V. (1999). Invariant Rectifying Stripping Curves for Targeting Minimum Energy and Feed Location in Distillation. *Comp. Chem. Eng.*, 23(8), 1109-1124.
- [10] Franklin, N.L., & Wilkinson, M.B., (1982). Reversibility in the Separation of Multicomponent Mixtures. *Trans. IChemE*, 60, 276-282.
- [11] van der Ham, L.V., & Kjelstrup, S., (2010). Exergy Analysis of Two Cryogenic Air Separation Processes. *Energy*, 35(12), 4731-4739.
- [12] Zemp, R.J., De Faria, S.H.B., & Maia, M.L.O. (1997). Driving Force Distribution and Exergy Loss in the Thermodynamic Analysis of Distillation Columns. *Computer and Chemical Engineering*, 21S, S523-S528.

- [13] Chang, H., & Li, Jr-W. (2005). A New Exergy Method for Process Analysis and Optimization. *Chemical Engineering Science*, 60(10), 2771-2784.
- [14] Samtana, E.I., & Zemp, R.J. (2005). Thermodynamic Analysis of a Crude-Oil Fractionating Process. *Proceedings of the 2nd Mercosur Congress on Chemical Engineering and the 4th Mercosur Congress on Process Systems Engineering, Angra do Reis*.
- [15] Faria, S.H.B., & Zemp, R.J. (2005). Using Exergy Loss Profiles and Enthalpy-Temperature Profiles for the Evaluation of Thermodynamic Efficiency in Distillation Column. *Thermal Engineering*, 4(1), 76-82.
- [16] De Koeijer, G., & Rivero, R. (2003). Entropy Production and Exergy Loss in Experimental Distillation Columns. *Chemical Engineering Science*, 58(8), 1587 – 1597.
- [17] De Koeijer, G.M., & Kjelstrup, S., (2004). Application of Irreversible Thermodynamics to Distillation. *International Journal of Thermodynamics*, 7(3), 107-114.
- [18] Wankat, P.C., & Kessler, D.P. (1993). Two-Feed Distillation: Same-Composition Feeds with Different Enthalpies. *Industrial and Engineering Chemistry Research*, 32(12), 3061-3067.
- [19] Bandyopadhyay, S. (2002). Effect of Feed on Optimal Thermodynamic Performance of a Distillation Column. *Chemical Engineering Journal*, 88(1-3), 175-186.
- [20] Bandyopadhyay, S. (2006). Thermal Integration of a Distillation Column Through Side-Exchangers. *ICHEME Symposium*, 152, 162-171.
- [21] Douani, M., Terkhi, S., & Ouadjenia, F. (2007). Distillation of a Complex Mixture. Part II: Performance Analysis of a Distillation Column Using Exergy. *Entropy*, 9(3), 137-151.
- [22] Le Goff, P., Cachot, T., & Rivero, R. (1996). Exergy Analysis of Distillation Processes. *Chemical Engineering Technology*, 19(6), 478-485.
- [23] Jimenez, E.S., Salamon, P., & Rivero, R. (2004). Optimization of a Diabatic Distillation Column with Sequential Heat Exchangers. *Ind. Eng. Chem. Res.*, 43(23), 7566-7571.
- [24] Kjelstrup, S., & Rosjorde, A. (2005). The Second Law Optimal State of a Diabatic Binary Tray Distillation Column. *Chemical Engineering Science*, 60(5), 1199-1210.
- [25] Rivero, R. (2001). Exergy Simulation Optimization of Adiabatic and Diabatic Binary Distillation. *Energy*, 26(6), 561-593.
- [26] Sauar, E., Rivero, R., Kjelstrup, S., & Lien, K.M. (1997). Diabatic Column Optimization Compared to Isoforce Columns. *Energy Conversion and Management*, 38(15-17), 1777-1783.
- [27] Schaller, M., Hoffman, K.H., Siragusa, G., Salamon, P., & Andersen, B. (2001). Numerically Optimized Performance of Diabatic Distillation Column. *Computers and Chemical Engineering*, 25(11-12), 1537-1548.
- [28] Huang, K., Shan, L., Zhu, Q., & Qian, J. (2008). A Totally Heat-Integrated Distillation Column (THiDiC) - the Effect of Feed Pre-heating by Distillate. *Applied Thermal Engineering*, 28(8-9), 856-864.
- [29] Khoa, T.D., Shuhaimi, M., Hashim, H., & Panjeshahi, M.H. (2010). Optimal Design of Distillation Column Using Three Dimensional Exergy Analysis Curves. *Energy*, 35(12), 5309-5319.
- [30] Seader, J.D., & Henley E.J. (2006). *Separation Process Principles*.
- [31] Friday, R., Smith, B.D. (1964). An Analysis of The Equilibrium Stage Separations Problem-Formulation and Convergence. *AIChE J.*, 10(5), 698-707.
- [32] Wang, J.C., & Henke, G.E. (1966). Tridiagonal Matrix for Distillation. *Hydrocarbon Processing*, 45(8), 155-163.
- [33] Sharma, R., Jindal, A., Mandawala, D., & Jana, S.K. (1999). Design/ Retrofit Targets of Pump-Around Refluxes for Better Energy Integration of a Crude Distillation Column. *Ind. Eng. Chem. Res.*, 38(6), 2411-2417.
- [34] *Aspen HYSYS Version* (20.0.0.6728). (2006). Cambridge, Massachusetts, U.S.A.: Aspen Technology, Inc.