



Advances in Petroleum Exploration and Development
Vol. 5, No. 1, 2013, pp. 71-76
DOI:10.3968/j.aped.1925543820130501.1136

ISSN 1925-542X [Print]
ISSN 1925-5438 [Online]
www.cscanada.net
www.cscanada.org

Technology for Improving Life of Thermal Recovery Well Casing

TANG Zhijun^[a]; ZHOU Yanjun^[a]; JIA Jianghong^{[a],*}

^[a] Institute of Drilling Technology, Shengli Petroleum Administration Bureau, Dongying, Shandong, China.

* Corresponding author.

Received 20 February 2013; accepted 18 March 2013

Abstract

In steam injection process, casing is heated by steam, the change of casing temperature produces thermal stresses in the casing, the casing deforms when stresses exceed the yield point of its material. Casing failure is becoming increasingly prominent in thermal recovery wells, which severely restricts the development effect of such reservoirs, improving casing life of thermal recovery well has become a urgent problem to be solved. Through on-site survey and analysis, reasons for casing damage were determined as follows: strength change by high temperature, sand flow over of oil formation, poor cementing, unfavorable heat insulation and bad material for casing. In order to improve casing life, the supporting measures are introduced, the measures include pre-stress cementing technology, using casing head, thermal stress compensator, high-performance insulation tubing, high temperature cement slurry system, FRT110H special casing, and early sand control completion technology. Field application of these measures has gotten better effect in Shengli oilfield in recent years, the damage rate of thermal recovery well has decreased obviously, and this can provide reference for the efficient development of similar reservoirs at home and abroad.

Key words: Casing failure; Thermal recovery wells; Special casing; Cementing; Sand control completion

Tang, Z. J., Zhou, Y. J., & Jia, J. H. (2013). Technology For Improving Life of Thermal Recovery Well Casing. *Advances in Petroleum Exploration and Development*, 5(1), 71-76. Available from: URL: <http://www.cscanada.net/index.php/aped/article/view/j.aped.1925543820130501.1136> DOI: <http://dx.doi.org/10.3968/j.aped.1925543820130501.1136>

INTRODUCTION

Thermal recovery well technologies, such as cyclic steam stimulation (CSS) and steam assisted gravity drainage (SAGD), have been widely used in the production of heavy oil reservoir. Investigation indicates that a large portion of these casing string and connection failures can be attributed to the severe loading conditions of these applications (Kaiser *et al.*, 2005). A common feature for thermal recovery wells is the cyclic thermal loading with high peak temperatures that may result in high thermally-induced stresses, which typically exceed the elastic limit of the material and cause the casing and connection deformed plastically (Kaiser, 2005). In addition, curvature loading resulting from casing buckling and formation shear movement is also a critical load condition that inducing thermal recovery well casing and casing connection failure. Therefore, ensuring adequate structural integrity and seal ability of the connections over the full service life of a thermal recovery well is a significant challenge. In this work, the casing failure mechanism was investigated and the integrated technical measures were introduced, application results show that the proposed technique can effectively improve the thermal recovery well casing life and have good popularizing application value.

1. REASONS FOR CASING FAILURE IN THERMAL RECOVERY WELLS

1.1 High Temperature and Severe Temperature Changes

During steam injection, casing expands when it is heated. Axial stress inside the casing is compressive when the two terminals of the casing are fixed. When the axial stress exceeds the yield point, it can not be effectively released. Thus, the axial stress changes to side stress and therefore casing failure occurs due to the production of plastic

deformation or permanent deformation of the casing. When steam injection stops and the temperature declines, this will cause the casing stretched (Gao, 2002; Maruyama & Inoue, 1989). Therefore, the compressive stress changes to tensile stress. When it exceeds the yield point, casing failure occurs due to the excessive tensile stress at the casing joints or casing main body. Casing is exposed to temperature change by heating and cooling for several times per year during the extra heavy oil production due to 3-4 cycles of huff & puff operation for a single well.

1.2 Sand Flow over of Oil Formation

Formation sanding-out can cause rock skeleton structure distorted. Therefore, the overlying formation loses the support to some degree in space or the supporting force decreases, the original stress is unbalanced and the formation deforms vertically caused by forces from such as collapsing and compacting. In this case, when the cementation between the casing and overlying formation and between the casing and underlying formation is good, the deformation would transfers to the casing where a big amount of vertical stress would exert on the casing (Lin *et al.*, 2007; Li *et al.*, 2009). When the cementation is not good, a relative slip movement happens, resulting in a big friction in the casing. It is found that in sanding-out formation, there are two types of casing deformations, namely, an elliptical deformation and squeezing deformation (Zhang *et al.*, 2008; Bruno, 2002). Therefore there are relatively two types of casing failures, namely, beam column buckling bending exerted by vertical stress in an approximate long shank and cylindrical flexion.

1.3 Casing Material

If there are micro pores or slits in casing, its thread does not meet the engineering requirements, or shearing strength and tensile strength are lower than the standard value, casing failure will happen during the long term steam injection after well completion.

1.4 Poor Cementing Quality

During steam injection, shearing stress between casing and cement sheath will be generated because their linear expansion coefficient is different (Chen *et al.*, 2009). When the maximum bonding force between casing and cement sheath is smaller than the shearing stress, casing will be separated from cement sheath. So it will be easily damaged under thermal stress.

1.5 Non-Effective Thermal Insulation

In heavy oil thermal recovery wells, insulated tubing or "insulated tubing + oil tube" are often used, and packer is often placed to seal the annulus space between tube and casing (Yang *et al.*, 2005). However, if insulated tubing and packer are non-effective, thermal stress will directly act on the casing and cause casing failure.

2. SUPPORTING MEASURES FOR IMPROVING LIFE

A number of technologies for preventing casing failure were adopted in thermal recovery wells in Shengli oilfield, the techniques include pre-stress cementing Technology, using casing head, thermal stress compensator, high-performance insulation tubing, high temperature cement slurry system, special casing, early sand control completion technology, which are described as follows.

2.1 Pre-Stress Cementing Technology

Pre-stressed cementing is a kind of technique which a stress is applied on the casing string in the well before solidification of the cement slurry (generating pre-stress in the casing) (Li, 2003). This technique can decrease or counteract the elongation of the hot casing and avoid casing damage. To apply pre-stress, the bottom of the casing must be firmly anchored. Earth anchor is a kind of tool used to secure the bottom of the casing, its schematic diagram is showed as Figure 1 and the main technical specifications were showed in Table 1.



Figure 1
Schematic Diagram of Earth Anchor

Table 1
The Main Technical Specifications of Earth Anchor

No.	Specifications	7"Solid anchor	9-5/8"Hollow anchor
1	Body diameter	190~194 mm	285mm
2	Shear stress	5~7MPa	6~8MPa
3	Maximum working pressure	15~20 MPa	15~20 MPa
4	Anchor claw series	Two stage	One stage or two stage
5	Anchor fluke opening diameter	600 mm	600mm
6	Tool Length	3000~4000mm	1500~3000mm
7	Main tensile strength	1500~2000kN	2000~2500kN
8	Adapt to borehole	210~400mm	300~450mm
9	Body Material	N80, 35CrM	N80, 35CrMo
10	Working temperature	350°C	350°C
11	Connecting thread	BTC/LTC	BTC/LTC

The main features of earth anchor are as follows: (1) The first level short claw solves shrink diameter borehole anchor. (2) The secondary long claws solves loose stratum and out-of-round oversized hole. (3) The two anchor

claws open in turn, and the first level power is shortage, the second one automatically opens, which guarantees the different requirement of wells diameter anchor. (4) High strength dual-class four claws symmetrical layout can make the casing force uniform and keep the casing centered. (6) Safety agency can ensure using process safely and reliably.

2.2 Using Casing Head

A new type of casing head is developed in view of the problems encountered in preceding stress cementing in thermal production well. Casing head schematic diagram is showed as Figure 2.

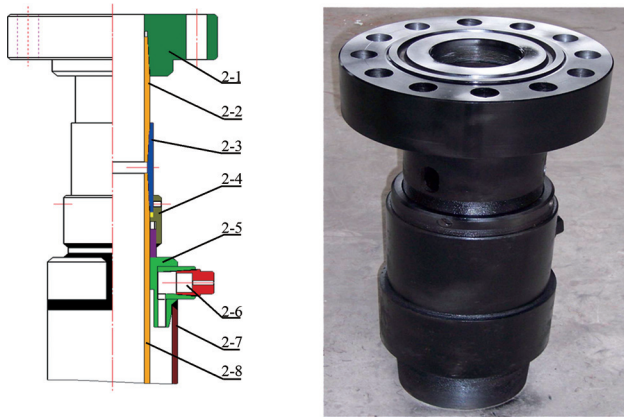

Figure 2
Schematic Diagram of Casing Head

The main features of casing head is as follows: (1) Production casing and flange directly connected by standard casing silk buckle without rubber seal can resist high temperature and high pressure. (2) The adjustment device is used to facilitate pre-stress construction and wellhead installation and fixation. (3) Equipped with back note hole, it can repeatable meet to annulus crowded cement.

The wide application of this casing head on site reveals that it can meet the production requirements by effectively controlling the casing elongation from heating, so it can contribute to the pre-stress cementing operation.

2.3 Using Thermal Stress Compensator

Thermal stress compensator installed at a proper position on the casing string allows for a certain axial elastic deformation which mitigates the thermal stress and restrains the internal stress within the yield limits. The main function as follows: (1) A function of axial stretching (Expansion distance 150 mm-160 mm). (2) Solution of local casing damage. (3) Useful complement to Pre-stress completion technology. There are two thermal compensator used in Shengli oil field: Pin type thermal compensator and intelligent thermal stress compensator.

2.3.1 Pin Type Thermal Stress Compensator

Pin type thermal stress compensator was sealed by HTHP seal bellows welded to upper and lower buckets placed at the stretching resistance pedestal seat on the central line. To prevent axial displacement of the center tube and limit joint when trip in, a snap head flat key is applied. The HTHP seal bellows were in a state of nature, when the outer tube moved upward, it would be stretched, compressed conversely. Production casing would be slightly stretched by thermal stress, which is the main cause of casing failure. Thermal stress compensator placed above the reservoir can compensate the slight stretch of the production casing, so as to prevent casing failure (Yu & Bao, 2005). When placed at the top of the reservoir where the production casing failure occurs most frequently, it can serves as wellhead protector. The schematic diagram of pin type thermal compensator is showed as Figure 3 and the main technical specifications were showed in Table 2.

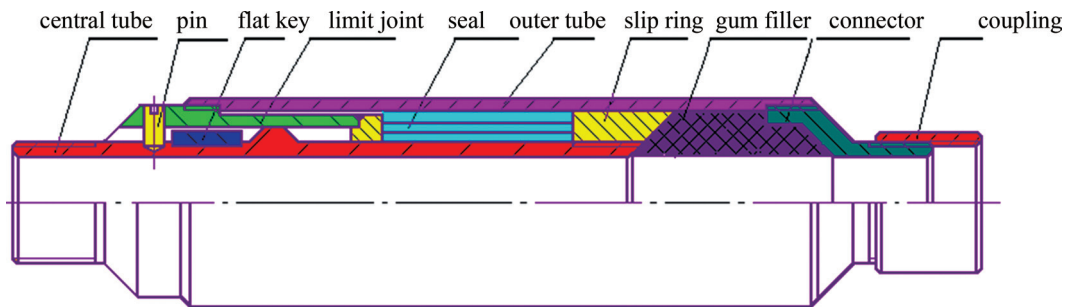

Figure 3
Schematic Diagram of Pin Type Thermal Stress Compensator

Table 2
The Main Technical Specifications of Pin Type Thermal Stress Compensator

Type	Specifications	Tensile strength (kN)	Collapsing strength (MPa)	Working temperature (°C)	Working pressure (MPa)	The largest diameter (mm)	Inside diameter (mm)	Expansion (mm)
Pin type	7"	2660	26.9	≤350	≤20	219	160	150
Intelligent type	7"	2660	26.9	≤350	≤20	219	160	160

2.3.2 Intelligent Thermal Stress Compensator

The intelligent thermal stress compensator adopts temperature sensitive material as the startup device, and it is in the state of dead lock in normal temperature, preventing the string from stretching out axially. When the temperature value reaches the set value, the compensator is in the open state to set free the string, keeping

the strings at both ends of the compensator in free extension. The purpose of reducing stress concentration and protecting the string is reached by compensating the extension of the string. The schematic diagram of intelligent thermal stress compensator is showed as Figure 4 and the main technical specifications were showed in Table 2.

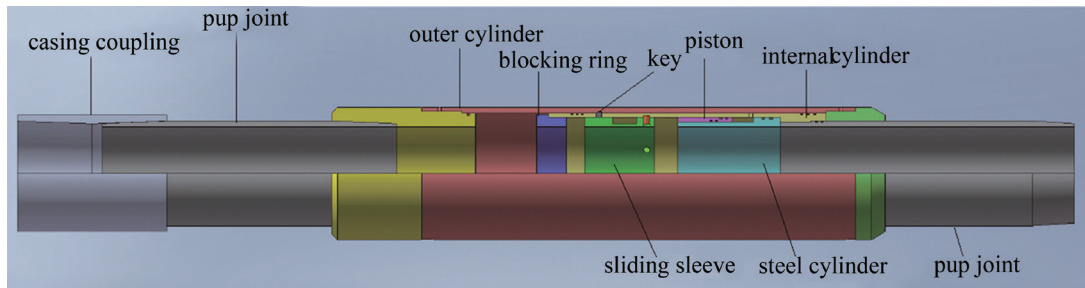

Figure 4
Schematic Diagram of Intelligent Thermal Stress Compensator

2.4 Adopting High-Performance Insulation Tubing

Different insulation measures have great effect upon casing stress, and high-performance insulation pipe can significantly decrease equivalent stress on casing wall. For ordinary tubing, the coefficient of thermal conductivity is $56.5 \text{ W/(m}\cdot\text{°C)}$, for high vacuum insulation tubing, the coefficient of thermal conductivity is lower than $0.003 \text{ W/(m}\cdot\text{°C)}$. Assuming steam temperature of 350 °C and steam injection pressure of 20 MPa , for a casing with wall thickness of 9.19 mm , numerical simulation results show that the equivalent stress of casing is 552 MPa using ordinary tubing and 200 MPa using high vacuum insulation tubing, a 63.8% decrease in equivalent stress for a high vacuum insulation tubing. Therefore, the

high vacuum insulation tubing can effectively protect the casing from damage.

2.5 Using High Temperature Cement Slurry System

The conventional class G oil well cement with silica sands can not effectively meet the quality of oil well cementing and requirements of exploration and production as its poor resistance to high temperature. Through the test of cement stone strength at high temperature and optimization of material and additive, a new cement slurry system for thermal recovery well was developed, and the cement slurry properties were evaluated in laboratory test, cement slurry formula is showed in Table 3, the basic properties of cement slurry system is showed in table 4, the high temperature performance of cement stone is showed in Table 5.

Table 3
Formula for Thermal Recovery Well

NO.	Class G cement (g)	Reinforcing agent (%)	Reinforcing material (%)	Dispersing agent (%)	Fluid loss additive (%)	Retarders (g)	Defoamers (%)	Early strength accelerator (%)
1	800	35	8	1.8	1.0	0.25	0.07	3
2	800	35	8	1.2	1.0	0.3	0.07	4
3	800	35	8	1.2	1.2	0.3	0.07	4.5

Table 4
The Basic Properties of Cement Slurry System

NO.	Density(g/cm^3)	Temperature($^{\circ}\text{C}$)	Fluidity(cm)	Early thickening(BC)	Free water(mL)	API fluid loss(mL)	Compression strength (MPa)	Thickening time (MIN)
1	1.88	50	22	9	0	39	19.6	206
2	1.89	50	22	12	0	40	19	180
3	1.9	50	21	12	0	40	18.9	164

Table 5
The High Temperature Performance of Cement Stone

NO.	Compression strength of conventional cement stone(MPa)			Compression strength of the new cement stone(MPa)		
	280 $^{\circ}\text{C}$	320 $^{\circ}\text{C}$	350 $^{\circ}\text{C}$	280 $^{\circ}\text{C}$	320 $^{\circ}\text{C}$	350 $^{\circ}\text{C}$
1	16.5	12.40	4.5	15.3	14.5	13.9
2	17.6	11.02	4.0	13.5	13.0	12.7
3	18.9	12.40	4.2	15.6	14.3	14.0

From Tabled 4 and 5, it can be see that the cement slurry system has good fluidity, low early thickening, low API fluid loss and good resistance to high temperature, which can meet the requirements of thermal recovery wells cement.

2.6 Using Special Casing for Thermal Recovery Well

An entirely new patented casing product was developed usually called Non-API casing based on strain criterion. Control casing material yield-strength ratio and increase the elongation rate are the key problem to be solved, so Cr-Mn steel is used instead of the traditional steel, laboratory test shows that Cr-Mn steel can control the material yield strength ratio economically and increase the elongation rate. Through many laboratory tests, the new casing products FRT110H for thermal recovery were developed; this casing extends the life of thermal recovery well by its capability to endure more than ten gas /steam cycles, which has high connectivity, and reliable gas tightness. The performance comparison results of FRT110H casing with N80 casing are showed as Figure 5.

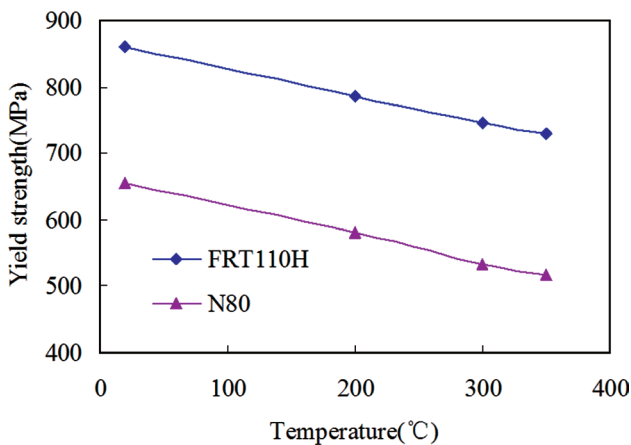

Figure 5
Casing Performance Comparison at High Temperature

From Figure 5, we can see N80 casing can withstand the maximum thermal stress of not more than 518MPa, but FRT110H at least able to withstand 731 MPa, when temperature up to 350 °C, the FRT110H casing yield strength decreased by 15%, while the N80 casing decreased by 21%, FRT110H casing has better high temperature resistance than N80 casing, which can fully meet production requirements of thermal recovery wells.

2.7 Using Early Sand Control Completion Technology

Because of viscous oil reservoir with formation cementation and steam injection pipelines for hot extraction, the sand production is more serious. The sand

production not only affects the normal production of oil but also accelerates the casing damage. several series for viscous oil reservoir sand control sieve tubes have been developed, which includes slotted screen(Figure 6), precision screen(Figure 7) and expandable sand screen(Figure 8).

Slotted pipe is cut out a plurality of specifications of the longitudinal or spiral straight rows in the petroleum casing by using ultra-thin films and beam as cutter, the slit width is about 0.2~0.5 mm, cross section of slit is rectangular, trapezoidal (angle of 3-8 degrees), special shape and other forms.

Precision filter sand tube is widely applied for early sand control wells in Shengli Oilfield, which the minimum value of sand control particle size can reach 0.07 mm. The precision filter sand tube has good sand control capacity, which is consisted of base pipe, filter layer, the outer protective sleeve and end ring. The precision filter sand tube is suitable especially for the siltstone geology: it can be extensively applied for well completion or sand control in the horizontal well, side-tracked well and branch well.

Expandable sand screens have been used successfully in various locations and offer many advantages. The screen assembly consists of a slotted base pipe and outer protective shroud with filtration media sandwiched between base pipe and shroud. A cone is run through the slotted base pipe to force the slots open and expand the diameter by as much as 50%. Holes in the outer protective shroud are opened further during the expansion process. The filtration media has leaves of filter layer overlapped before expansion that slide over each other during expansion to maintain the original filtration integrity.

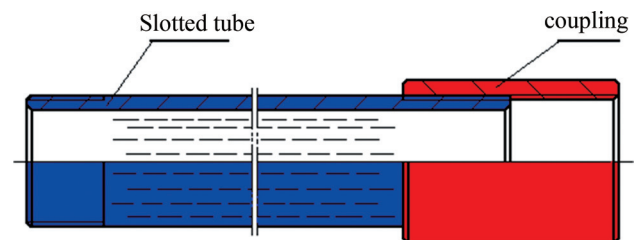

Figure 6
Schematic Diagram of Slotted Screen

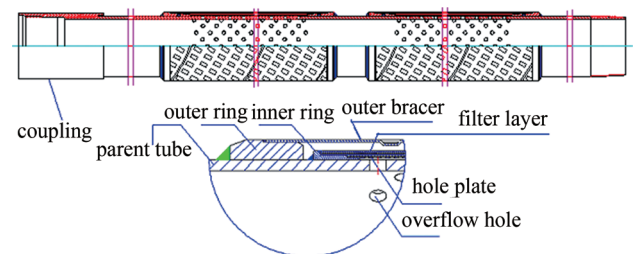

Figure 7
Schematic Diagram of Precision Filter Sand Tube



Figure 8
Schematic Diagram of Expandable Sand Screen

3. FIELD APPLICATION

The supporting measures were applied in the LuMing block, Dongxin block, Xianhe oil production factory, Hekou Oil Production factory, Binnan Oil production factory, spring oil production factory, the accumulative application wells were more than 400 wells, 80 percent of thermal recovery wells can endure more than ten gas/steam cycles, which effectively improved the thermal well casing life and achieved good results.

CONCLUSION

(1) Casing deformation and failure in thermal recovery wells is serious, the direct reason for casing failure is due to the expansion when it is heated, when the axial stress can not be released, the axial stress becomes side stress and casing is deformed and cut.

(2) The influencing factors of casing damage include strength change by high temperature, sand flow over of oil formation, poor cementing, unfavorable heat insulation and bad material for casing et al.

(3) Through the using of new thermal well casing, high-performance insulation tubing, high temperature cement slurry system and other technical measures, thermal well casing life can be improved and can reduce casing failure effectively.

REFERENCES

- [1] Kaiser, T. M. V., Yung, V. Y. B., & Bacon, R. M. (2005). Cyclic Mechanical and Fatigue Properties for OCTG Materials. *SPE/PS-CIM/CHOA International Thermal Operations and Heavy Oil Symposium*, 1-3 November 2005, Calgary, Alberta, Canada.
- [2] Kaiser, T. M. V. (2005). Post-Yield Material Characterization for Thermal Well Design. *SPE/PS-CIM/CHOA International Thermal Operations and Heavy Oil Symposium*, 1-3 November 2005, Calgary, Alberta, Canada
- [3] Gao, B. K. (2002). Practical Model for Calculating the Additional Load on Casing by High Temperature. *Oil Drilling & Production Technology*, 24(1), 8-10.
- [4] Maruyama, K., & Inoue, Y. (1989). An Experimental Study of Casing Performance Under Thermal Recovery Conditions. *SPE Drilling Engineering*, 5(2), 156-164.
- [5] Lin, F. L., Chen, M., & Zhang, G. Q. *et al.* (2007). Casing Failure Mechanism Analysis Induced by Reservoir Compaction and Sand in the Producing Layer. *Petroleum Drilling and Production Technology*, 29(2), 49-51.
- [6] Li, J., Lin, C. Y., & Yang, S. H. *et al.* (2009). Analysis on Mechanism of Casing Damage and Strength Design for Heavy Oil Wells. *Oil Field Equipment*, 38(1), 9-13.
- [7] Zhang, Y., Kuang, Y. C., & Wu, K. S. *et al.* (2008). Research on Casing Failure Mechanism of Thermal Production Well Based on Finite Element Method. *Drilling. Production Technology*, 32(4), 102-104.
- [8] Bruno, M. S. (2002). Geomechanical and Decision Analyses for Mitigating Compaction Related Casing Damage. *SPE Annual Technical Conference and Exhibition*, 30 September-3 October 2001, New Orleans, Louisiana.
- [9] Chen, Y., Lian, Z. H., & Chen, R. M. (2009). Analysis for Casing Safety Evaluation Based on Residual Stress in Thermal Well. *Oil Field Equipment*, 38(4), 16-19.
- [10] Yang, X. J., Yang, L., & Jia, S. P. *et al.* (2005). The Finite Element Analysis of the Casing Failure Mechanisms of Thermal Recovery Wells in Sand Production. *Oil Field Equipment*, 34(2), 19-23.
- [11] Li, W. Z. (2003). The Mechanism and Prevention of Casing Damage in Ultra Thick Oil Well of Shuguang Oilfield. *Drilling & Production Technology*, 26(2), 55—57.
- [12] Yu, L., Bao, M. (2005). New Technology for Easing Damage Prevention and Cure of Thermal Production Wells in Liaohe Oilfield. *Petroleum Exploration and Development*, 32(1), 116-118.