

---

Electronic Theses and Dissertations, 2004-2019

---

2009

## Post Treatment Alternatives For Stabilizing Desalinated Water

Susaye Douglas  
*University of Central Florida*

 Part of the [Environmental Engineering Commons](#)  
Find similar works at: <https://stars.library.ucf.edu/etd>  
University of Central Florida Libraries <http://library.ucf.edu>

This Masters Thesis (Open Access) is brought to you for free and open access by STARS. It has been accepted for inclusion in Electronic Theses and Dissertations, 2004-2019 by an authorized administrator of STARS. For more information, please contact [STARS@ucf.edu](mailto:STARS@ucf.edu).

---

### STARS Citation

Douglas, Susaye, "Post Treatment Alternatives For Stabilizing Desalinated Water" (2009). *Electronic Theses and Dissertations, 2004-2019*. 4065.  
<https://stars.library.ucf.edu/etd/4065>

**POST TREATMENT ALTERNATIVES FOR STABILIZING  
DESALINATED WATER**

by

SUSAYE S DOUGLAS  
B.S. University of Central Florida, 2007

A Thesis submitted in partial fulfillment of the requirements  
for the degree of Master of Science  
in the Department of Civil, Environmental, and Construction Engineering  
in the College of Engineering and Computer Science  
at the University of Central Florida  
Orlando, Florida

Summer Term  
2009

©2009 Susaye S Douglas

## **ABSTRACT**

The use of brackish water and seawater desalination for augmenting potable water supplies has focused primarily on pre-treatment, process optimization, energy efficiency, and concentrate management. Much less has been documented regarding the impact of post-treatment requirements with respect to distribution system.

The goals of this study were to review current literature on post-treatment of permeate water, use survey questionnaires to gather information on post-treatment water quality characteristics, gather operation information, review general capital and maintenance cost, and identify appropriate “lessons learned” with regards to post-treatment from water purveyors participating in the Project. A workshop was organized where experts from across the United States, Europe and the Caribbean active in brackish and seawater desalination, gathered to share technical knowledge regarding post-treatment stabilization, identify solutions for utilities experiencing problems with post-treatment, note lessons learned, and develop desalination water post-treatment guidelines. In addition, based on initial workshop discussions, the iodide content of reverse osmosis and nanofiltration permeate from two seawater desalination facilities was determined.

The literature review identified that stabilization and disinfection are required desalination post-treatment processes, and typically are considerations when considering 1) blending, 2) re-mineralization, 3) disinfection, and 4) materials used for storage and transport of product water. Addition of chemicals can effectively achieve post-treatment goals although considerations relating to the quality of the chemical, dosage rates, and possible chemical reactions, such as possible formation of disinfection by-products, should be monitored and studied.

The survey gathered information on brackish water and seawater desalination facilities with specific regards to their post-treatment operations. The information obtained was divided into seven

sections 1) general desalination facility information, 2) plant characteristics with schematics, 3) post-treatment water quality, 4) permeate, blend, and point of entry quality, 5) post-treatment operation, 6) operation and maintenance costs, 7) and lessons learned. A major consideration obtained from the survey was that facilities should conduct post-treatment pilot studies in order to identify operational problems that may impact distributions systems prior to designing the plant. Effective design and regulation considerations will limit issues with permitting for the facility.

The expert workshop identified fourteen priority issues pertaining to post-treatment. Priority issues were relating to post-treatment stabilization of permeate water, corrosion control, disinfection and the challenges relating to disinfection by-product (DBP) formation, water quality goals, blending, and the importance of informing the general public. For each priority issues guidelines/recommendations were developed for how facilities can effectively manage such issues if they arise.

One of the key priorities identified in the workshop was related to blending of permeate and formation of DBPs. However, it was identified in the workshop that the impact of iodide on iodinated-DBP formation was unknown. Consequently, screening evaluations using a laboratory catalytic reduction method to determine iodide concentrations in the permeate of two of the workshop participants: Tampa Bay and Long Beach seawater desalination facilities. It was found that the permeate did contain iodide, although at levels near the detection limit of the analytical method (8 µg/L).

This Thesis is dedicated to my parents, grandpa, and especially my sisters Tricia, Karone, and Kamala for all the love and support they have given me.

## ACKNOWLEDGEMENTS

Special thanks to Dr. Steven Duranceau for serving as my advisor and for his patience, guidance, and support through this project. I want to thank Dr. David Cooper for his advice and encouragement at times when I needed it the most. Thanks to Dr. Andrew Randall for serving on my committee. Thanks to the Water Research Foundation for funding this project and the National Water Research Institute (NWRI) for providing workshop assistance. Thanks to the following utilities for participating in the project, their time and valuable input that was necessary for completion of this project and is greatly appreciated.

Irvine Ranch Water District, Irvine, CA	Carl Spangenberg
San Diego County Water Authority, San Diego, CA	Cesar Lopez, Jr.
MWD of Southern California, Los Angeles, CA	Sun Liang
Long Beach Water Department, Long Beach, CA	Robert Cheng
City of Pompano Beach, Pompano Beach, FL	Donald Baylor
Collier County Utilities, Naples, FL	Steven Messner
Tampa Bay Water, Tampa, FL	Christine Owen
Town of Jupiter Utilities, Jupiter, FL	Paul Jurczak
El Paso Public Water Utilities Services, El Paso, TX	Fernie Rico
Naval Facilities Engineering Command, Norfolk, VA	James Harris
Consolidated Water Company, LTD, Cayman Islands	John Countz
PWN Water Supply Co. North Holland, Netherlands	Gilbert Galjaard

Thanks to Maria Pia Real-Robert, Nancy P. Holt, William J. Johnson, Vito Trupiano, and Jayapregasham Tharamapalan for their help when I needed the most, and a special thanks to Amalia

Abdel-Wahab for her time spent with me in the laboratory completing iodide testing. All your time and effort is sincerely appreciated.



## TABLE OF CONTENTS

LIST OF FIGURES.....	xii
LIST OF TABLES .....	xiv
LIST OF ACRONYMS.....	xv
CHAPTER ONE: INTRODUCTION .....	1
Overview .....	1
Study Objective.....	2
Background.....	2
Desalination for Drinking Water Production .....	2
Synthetic Membrane Processes .....	3
Theory .....	5
Osmosis .....	5
Osmotic Flow .....	6
Permeate Concentration.....	10
CHAPTER TWO: LITERATURE REVIEW.....	16
Permeate Post-treatment .....	16
Introduction .....	16
Permeate Conditioning and Blending.....	16
Municipal Methods.....	17
Water Quality Considerations .....	20
Water Quality Parameters and Stability.....	21
Brackish Water Post-treatment Considerations .....	25
Seawater Post-treatment Considerations.....	31

Regulatory Considerations.....	33
Distribution Systems and Internal Corrosion Control.....	38
An Overview of the causes of Internal Corrosion .....	38
Indices for Predicting Corrosive and Scale Tendencies of a Water.....	44
Corrosion Indices and Boron.....	47
Corrosion Control Strategies And Stabilization.....	47
General Approaches .....	47
Stabilization of Desalted Permeate .....	55
Inhibitors .....	57
Blending Considerations.....	66
Blended Water Ratios .....	67
Impacts On Existing Distribution System Infrastructure.....	68
Blending Water Compatibility .....	68
Red Water Experiences.....	72
Permeate and Agriculture .....	75
Desalted Seawater Supplies and Permeate Boron Concentrations .....	75
Desalination and the Sodium Adsorption Ratio.....	78
Summary of Literature Review Findings.....	81
Chemicals and Post-treatment Issues .....	82
Brackish and Sea Water Post-treatment.....	83
Identified Water Quality Goals for Post-treatment Processes .....	85
CHAPTER THREE: PERMEATE POST TREATMENT PRACTICES QUESTIONNAIRE.....	86
Utility Questionnaire .....	86

Survey Response .....	87
Section I: Background Information .....	87
Section II: Plant Characteristics .....	92
Section III: Post-treatment Information .....	97
Section IV: Post-treatment Water Quality .....	105
Section V: Post-treatment Operations .....	112
Section VI: Post-treatment O&M Costs .....	113
Section VII: Major Issues and Lessons Learned .....	116
CHAPTER FOUR: EXPERT WORKSHOP .....	124
Introduction .....	124
Expert Workshop Methodology .....	124
Nominal Group Technique .....	124
Location and Purpose .....	127
Participants .....	128
Results and Discussion .....	129
Guideline for Priority Issues .....	135
CHAPTER FIVE: EVALUATION OF TOTAL IODIDE IN SEAWATER PERMEATE STREAMS .....	139
Introduction .....	139
Approach .....	140
Experimental Design .....	142
Results and Discussion .....	147
Quality Assurance and Quality Control .....	150

CHAPTER SIX: CONCLUSION AND RECOMMENDATIONS.....	152
Summary .....	152
Literature Review Findings .....	153
Conclusions .....	154
Questionnaire Findings.....	154
Expert Workshop Proves Beneficial Findings.....	156
Iodide Was Found to Be Present In Permeate .....	157
Recommendations .....	158
APPENDIX A: POST TREATMENT QUESTIONNAIRE.....	161
APPENDIX B: WORKSHOP AGENDA.....	176
APPENDIX C: NOMINAL GROUP TECHNIQUE WORKSHOP GUIDLINE AND PROCEDURES.....	179
APPENDIX D: PRIORITY ISSUE IDENTIFICATION FORM.....	181
REFERENCES.....	183

## LIST OF FIGURES

Figure 1-1: Example of a Simplified Membrane System Flow Diagram .....	6
Figure 1-2: The Principles of Osmotic Flow .....	8
Figure 1-3: Basic Diagram of Mass Transport in a Membrane .....	11
Figure 2-1: Effect of pH on Carbon Dioxide Concentration as a Fraction of Concentration .....	27
Figure 2-2: Effect of pH on Hydrogen Sulfide Species as a Fraction of Concentration .....	29
Figure 2-3: Alkalinity Recovery Process Flow Diagram.....	51
Figure 3-1: Distribution of Plants Surveyed .....	88
Figure 3-2: Plant Type Categorized by Feedwater TDS .....	89
Figure 3-3: Is Your Groundwater Under the Influence of Surface Water? .....	90
Figure 3-4: Type of Ownership .....	90
Figure 3-5: Water Quality Driver.....	91
Figure 3-6: Hydraulic Capacity.....	92
Figure 3-7: Plant Originally Designed for Expansion .....	93
Figure 3-8: Design Percent RO Feedwater Recovery.....	93
Figure 3-9: Design RO Membrane Flux.....	94
Figure 3-10: Design Pressure .....	95
Figure 3-11: Permeate Water End-Use.....	96
Figure 3-12: Source Water .....	96
Figure 3-13: Average Temperature, pH, and Alkalinity for Permeate, Blend, and Point of Entry ..	106
Figure 3-14: Average Turbidity and Color for Permeate, Blend, and Point of Entry .....	108
Figure 3-15: Average Conductivity and TDS for Permeate, Blend, and Point of Entry.....	108
Figure 3-16: RO Permeate Water Quality .....	110

Figure 3-17: Blend Water Quality.....	111
Figure 3-18: Point of Entry (POE) Water Quality.....	111
Figure 3-19: Frequency Distribution of the Average Daily NF/RO Permeate Production.....	112
Figure 3-20: Frequency Distribution of Reported Average Blend Flow .....	113
Figure 3-21: Operation and Maintenance Cost versus Plant Capacity.....	114
Figure 3-22: Operation and Maintenance Cost Breakdown by Cost Category .....	115
Figure 3-23: Energy cost versus Plant Capacity .....	115
Figure 3-24: Did pilot testing reveal water quality concerns for distribution system?.....	117
Figure 3-25: Did design of facility consider impacts of permeate on the distribution system? .....	118
Figure 3-26: With respect to post-treatment (disinfection), what obstacles were overcome to obtain permits/consents?.....	119
Figure 3-27: Did you experience issues in distribution system after plant startup and if so, what did you do to resolve the problem? .....	122
Figure 3-28: Are these issues in the distribution system that has been directly related back to post-treatment?.....	123
Figure 5-1: Iodide Calibration Curves.....	146
Figure 5-2: Tampa Bay Mean Iodide Concentrations with Max and Min Observations .....	148
Figure 5-3: Long Beach Mean Iodide Concentrations with Max and Min Observation.....	150

## LIST OF TABLES

Table 2-1: Typical Post-treatment Processes Based on Supply Type .....	19
Table 2-2: Pipe Material and Corrosion.....	43
Table 2-3: Operating Considerations of Typical Corrosion Inhibitors .....	62
Table 2-4: SAR Versus EC <sub>w</sub> .....	79
Table 2-5: Irrigation Goals for Bermuda Grass .....	80
Table 3-1: Post-treatment Types and Disinfection.....	98
Table 3-2: Post-treatment Disinfection and Disinfection Residual Goals .....	99
Table 3-3: Have you experienced any post-treatment problems within the plant?.....	100
Table 3-4: Any distribution system impacts noted?.....	101
Table 3-5: Blending or By-Pass Descriptions .....	102
Table 3-6: Sequence of Post-treatment Operations.....	103
Table 3-7: Control of pH and Buffering Content on Post-treatment.....	104
Table 3-8: Describe your Method of Corrosion Control.....	105
Table 3-9: Water Quality Parameters Not Provided by Respondees to the Questionnaire.....	109
Table 4-1: Example of Rankings for NGT .....	125
Table 4-2: Outline of Priority Issues Generated from Workshop.....	129
Table 5-1: Standard Solutions Concentrations .....	143
Table 5-2: Water Quality Parameters for samples.....	143
Table 5-3: Standard Curve Equations .....	145
Table 5-4: Iodide Concentrations for Tampa Bay RO Water .....	147
Table 5-5: Iodide Concentrations for Long Beach NF Water .....	149
Table 5-6: Quality Assurance and Control Parameters .....	151

## LIST OF ACRONYMS

AI	Aggressive Index
CCPP	Calcium Carbonate Precipitation Potential
CSI	Calcium Saturation index
DBP	Disinfection by-product
DIC	Dissolved Inorganic Carbon
DO	Dissolved Oxygen
EDR	Electro-dialysis
GW	Groundwater
GWUI	Groundwater under Influence
HRT	Hydraulic Retention Time
HPLC	High-performance Liquid Chromatography
KSCN	Potassium Thiocyanate
LCR	Lead Copper Rule
LSI	Langelier Saturation Index
MTC	Mass Transfer Coefficient
MCL	Minimum Contaminant Level
NF	Nanofiltration
POE	Point of Entry
RPD	Relative Percent Difference
RO	Reverse Osmosis
SOC	Synthetic Organic Carbon
SFW	Surface Water



TCR	Total Coliform Rule
TDS	Total Dissolved Salts
TOC	Total Organic Carbon
THMs	Trihalomethanes
UCL	Upper Control Limit
UWL	Upper Warning Limit
WTP	Water Treatment Plant

# CHAPTER ONE: INTRODUCTION

## Overview

Studies regarding the application and effectiveness of brackish and seawater desalination to augment drinking water supplies have focused primarily on pretreatment challenges, process optimization, energy efficiency, and concentrate management; however, less has been documented with regards to post-treatment requirements with respect to distribution system water quality impacts. The behavior of desalinated water in the distribution system remains largely non-documented, and potential issues that may arise after introducing desalinated water into existing distribution systems include impacts on internal corrosion control, disinfectants and disinfection by-products, hydraulics, infrastructure maintenance, water quality, aesthetics, and customer acceptance.

Potable water producers increasingly are turning to membrane processes to augment existing unit operations to improve water quality and allow reliance on poorer source waters. Moreover, the use of membrane processes for softening, brackish and seawater treatment has become more widespread around the globe. Although, in the United States of America (USA) seawater potable membrane applications are few, there has been long-term successful reliance on membrane treatment of brackish supplies, particularly in Florida, over the years. Although there is much knowledge in the professional community about membrane processes, water purveyors would benefit from documenting historical operation design, operation and implementation experience in a guidance document. To address this need, the research reported herein is intended to provide the drinking water community with information regarding post-treatment alternatives for stabilization of desalinated water.

## Study Objective

The Water Research Foundation funded this research to review current literature on post-treatment of permeate water, use survey questionnaires to gather information on post-treatment water quality characteristics, gather operation information, review general capital and maintenance cost, and identify appropriate “lessons learned” with regards to post-treatment from water purveyors, conduct an expert workshop to report practical experiences by water purveyors, denote lessons learned, and determine desalinated water post-treatment guidelines/recommendations linking water quality targets to distribution system operational goals. Consideration to customer acceptance of desalinated water is also reviewed. The five key tasks of the study included:

1. Conduct review of current literature on post-treatment of desalination water
2. Gather post-treatment water quality information through a survey questionnaire
3. Conduct an expert workshop
4. Denote lessons learned
5. Determine post-treatment guidelines (best practices) linking water quality targets to distribution system operational goals

## Background

### *Desalination for Drinking Water Production*

Desalination is an important and rapidly growing source of drinking water treatment around the world originating from seawater or brackish water. The use of synthetic membrane processes for desalination and production of drinking water has increased over the past five decades primarily in coastal areas with limited freshwater sources. Desalting techniques are primarily intended for the removal of total dissolved salts (TDS) that generally cannot be removed by conventional treatment

processes. Between 1994 and 2004, world desalination capacity increased from 17.3 to 35.6 million m<sup>3</sup>/day (Wagnick 2004).

However, synthetic membrane processes produce permeate water depleted in minerals and are often found to be aggressive towards distribution system components. Moreover, the water produced by membrane processes is typically incompatible with existing water distribution system infrastructure. Thus, post-treatment is needed for municipal water treatment before the membrane-treated water is delivered to the distribution system as finished water.

### *Synthetic Membrane Processes*

Since the development of synthetic asymmetric membranes in 1960, interest in membrane processes, particularly reverse osmosis (RO) and nanofiltration (NF) for water and wastewater treatment has increased primarily because of the following reasons (Mallevalle, Odendaal, and Wiesner 1996):

1. Increased regulatory pressure to provide better treatment for both potable and waste waters
2. Increased demand for water, especially during times of drought, requiring exploitation of water resources of poorer quality than those relied upon previously
3. Technological improvements have lowered costs associated with the manufacturing and operational use of membrane technologies

Water desalination had initially been used to produce or augment drinking water supplies through the use of evaporative or distillation methods. The process is believed to date back to the 4th century BC when Greek sailors used an evaporative process to desalinate seawater. Beginning in the 1970s however, the water industry began to focus on commercially viable desalination applications using synthetic membranes. Today, reverse osmosis (RO), nanofiltration (NF), and electro dialysis

reversal (EDR) are the most commonly used desalting processes for potable water treatment in the United States, typically treating brackish or impaired water supplies. Globally, many seawater RO water treatment plants (WTPs) have been operating successfully for more than 30 years (Redondo 2001; Busch and Mickols 2004).

At present time, desalting plants worldwide have the capacity to produce over 6.0 billion gallons a day, enough water to provide over 15 gallons a day for every person in the United States (Wagnick 2004). About 1,200 desalting plants are in operation nationwide. Most plants operating in the United States are used for either moderately brackish ground water treatment, for softening and natural organic matter (disinfection by-product precursors) removal, or to produce highly purified water for industrial use. The reverse osmosis process has the ability to remove more than ninety nine percent of all dissolved minerals and more than ninety-five percent of organic compounds, as well as biological and colloidal suspended matter, including turbidity, from water. Nanofiltration, also referred to as membrane softening, is used primarily for water softening and disinfection byproduct precursor (dissolved natural organic carbon) removal, and can remove up to ninety-five percent TDS from source water. Electrodialysis reversal (EDR) is employed for lower salinity waters, especially for surface waters having high fouling content or ground water having high silica content. EDR does not remove microorganisms or small suspended materials from source waters (Taylor, Duranceau, Barrett, and Goigel 1989).

The first commercial plant for the production of potable water from a saline source using electrodialysis and ion-exchange membranes was placed into operation in 1954 (Powell and Guild 1961). In 1968, use of membranes for brackish-water treatment started with the construction of an electrodialysis (ED) plant in Florida. This process was not well-received because of its inability to adequately reduce dissolved solids. The first RO treatment plant was constructed in 1970 for the

Ocean Reef Club, a condominium complex, on Longboat Key, Florida (Dykes and Conlon 1989). The plant began operation in October 1971 with an initial operating pressure of 600 psi and a capacity of 0.6 million gallons per day (MGD), and was later expanded to 0.93 MGD. Since that time, significant advances in membrane technologies have improved the cost effectiveness and performance capabilities of the membrane. RO membrane processes are increasingly being used worldwide to solve a variety of water treatment problems.

## Theory

### *Osmosis*

In general, membrane desalting process produces permeate water that is considered chemically unstable and low in mineral content, which can lead to corrosion within the distribution system. The mineral composition of the water is significantly changed and then partially reconstituted to achieve stable finished water that can be distributed in pipes. Whether or not the ultimate composition of the finished water has a positive or negative impact on the viability of distribution system components, distributed water quality, and health of long-term consumers of desalinated water supplies remains for the most part unknown.

Figure 1.2 presents a general flow diagram of a membrane process with an example post-treatment chemical feed sequence. The membrane system assumes pretreatment with cartridge filtration and energy recovery (not shown). RO, NF and EDR membrane treatment systems typically consist of pretreatment and post-treatment processes in addition to the membrane process. Most municipal plants have multiple membrane process trains installed in parallel, allowing flexibility in permeate (product water) production and ease of expansion. In some instances it is possible to bypass a portion of the raw or pretreated water around the membrane system and blend that flow

with the permeate stream to reduce the capacity of the membrane system, improve finished water stability, and minimize capital and operating costs (Bergman and Elarde 1995). The maximum allowable blend ratio is determined from an analysis of bypassed and permeate water qualities.

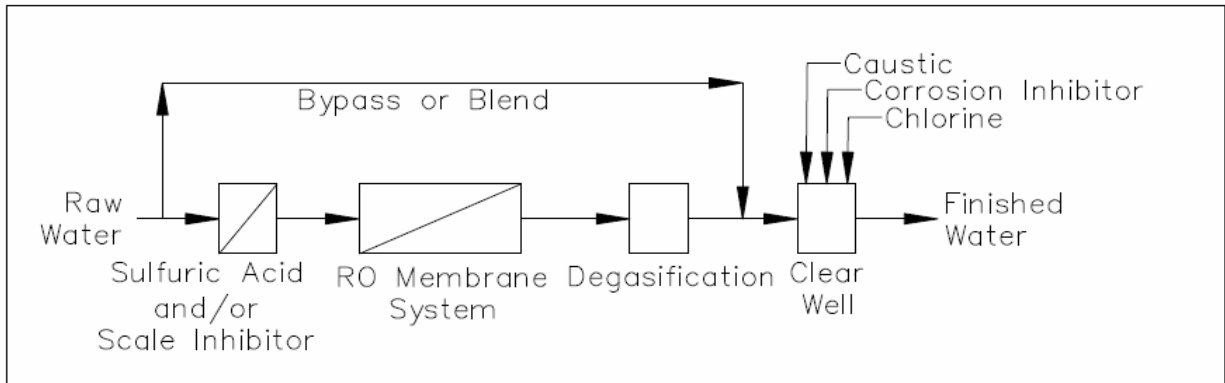

Figure 1-1: Example of a Simplified Membrane System Flow Diagram

Post-treatment processes typically include disinfection and corrosion control, and can include degasification and/or air stripping processes if carbon dioxide and hydrogen sulfide gases are present in the permeate water. Post-treatment is needed for municipal water treatment before the membrane-treated water is delivered to the distribution system as finished water. Membrane processes also produce a residual concentrate stream that may require post-treatment prior to disposal or reuse, such as the removal of hydrogen sulfide and/or addition of dissolved oxygen prior to surface water discharge; however, this document only discusses desalted process stream post-treatment.

### *Osmotic Flow*

It is known that diffusion is the movement of molecules from a region of higher concentration to a region of lower concentration. Figure 1.3 illustrates the concept of osmotic flow across a semi-permeable synthetic membrane. Osmosis is a special case of diffusion in which the

molecules are water and the concentration gradient occurs across a semi-permeable membrane. The semi-permeable membrane allows the passage of water, but not ions (e.g.,  $\text{Na}^+$ ,  $\text{Ca}^{2+}$ ,  $\text{Cl}^-$ ) or larger molecules (e.g., natural organic matter). Diffusion and osmosis are thermodynamically favorable and will continue until equilibrium is reached. Osmosis can be slowed, stopped, or even reversed if sufficient pressure is applied to the membrane from the 'concentrated' side of the membrane. Reverse osmosis occurs when the water is moved across the membrane against the concentration gradient, from lower concentration to higher concentration.



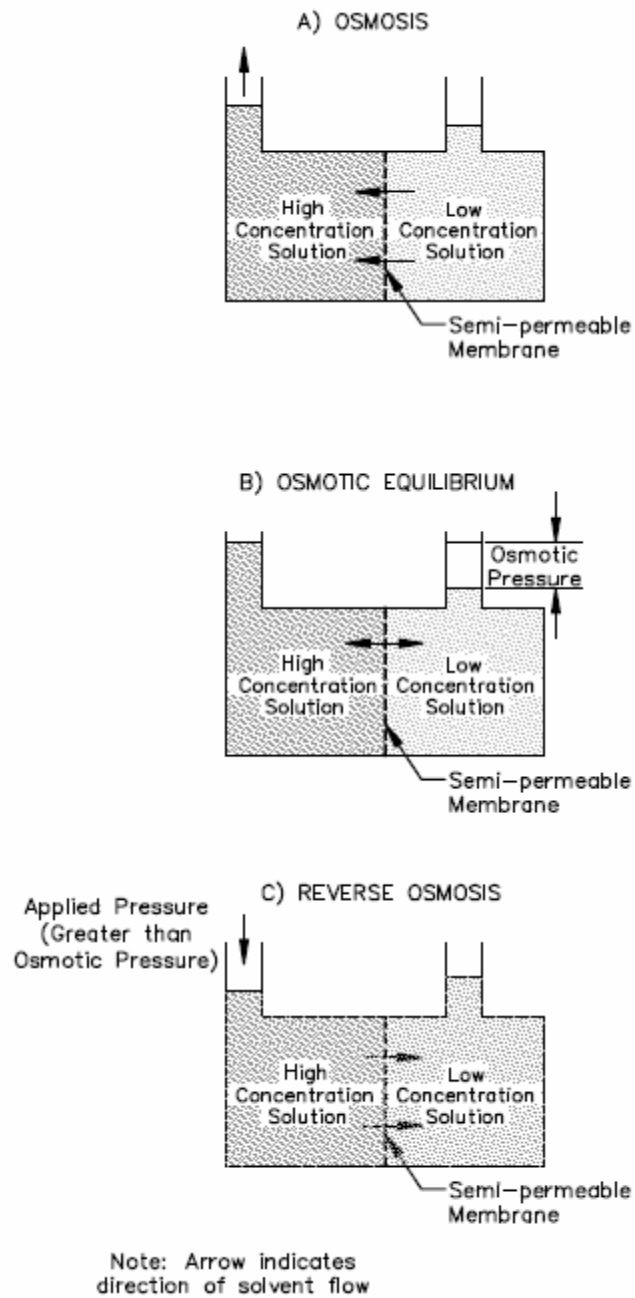

Figure 1-2: The Principles of Osmotic Flow

To illustrate, imagine a semi-permeable membrane with fresh water on one side and a concentrated aqueous solution on the other side. If normal osmosis takes place, the fresh water will cross the membrane to dilute the concentrated solution. In reverse osmosis, pressure is exerted on the side with the concentrated solution to force the water molecules across the membrane to the fresh waterside. Thermodynamically, the osmotic pressure is defined below in Equation (1.1) where

$$\pi = -\frac{RT}{V_b} \ln(x_w) \quad (1.1)$$

$\pi$  is the osmotic pressure,  $V_b$  the molar volume of water,  $x_w$  the mole fraction of water, and  $R$  the ideal gas constant. In dilute solutions, the osmotic pressure can be estimated using Van't Hoff's law, which was developed using the ideal gas law and is shown in Equation (1.2) with the total amount of

$$\pi = -\frac{n_s}{V} RT \text{ or } \pi = CRT \quad (1.2)$$

solute in solution  $n_s$  [moles], total concentration of solutes  $C$  [moles/L], and the volume of solvent  $V$ . Considering the dissociation of ions in solution, Van't Hoff's Equation is shown in Equation (1.3):

$$\pi = i\Phi CRT \quad (1.3)$$

with  $i$ , representing the dissociation constant, this is equal to the number of ions and molecules per mole of solute produced by the dissolution of the solute, and where  $\Phi$  represents a correction factor for non-ideal behavior.

As a general rule of thumb, for every 100 mg/L of total dissolved solids that is present in the feed water, one psi of osmotic pressure will be present within the membrane feed channel by Equation (1.4):

$$\pi = \left[ TDS, \frac{mg}{L} \right] \frac{1psi}{100mg/L-TDS} \quad (1.4)$$

For a general estimate of the osmotic pressure of seawater, it can be assumed that an NaCl solution of equal total dissolved solids concentration is approximated as shown by (Fritzmann, Lowenberg, Wintgens, and Merlin 2007) and represented by Equation (1.5):

$$\pi = \frac{8 \text{ bar}}{\text{wt}\%_{\text{NaCl}}} \quad (1.5)$$

It should be noted that the actual osmotic pressure of seawater has been shown to be approximately ten percent of a solution of sodium chloride, which is equal to the total dissolved solids concentration, due the presence of higher molar mass species that are present in the seawater (AWWA 1999). The permeate water quality is thus a function of diffusion of salt across the membrane and its associated osmotic pressure gradient, the trans-membrane pressure, water recovery, and mass transfer of solute and water with respect to membrane material. These parameters will affect downstream quality and hence post-treatment processes.

#### *Permeate Concentration*

There are many different theories and models describing mass transfer in diffusion controlled membrane processes (Yu and Taylor, 2004; Yu et al., 2004, Yu and Taylor, 2005), however a few basic principles or theories are used to develop most of these models. These are convection, diffusion, film theory and electro-neutrality. These principles or theories could be used to group models into linear diffusion models, exponential diffusion models and coupling models.

The homogeneous solution diffusion model is the basic model for describing the performance of membrane system (Weber 1972) where the water mass transfer flux is proportional to the pressure differential across the membrane (Kedem and Katchalsky 1958). One of the earliest published models for diffusion controlled mass transport in NF and RO processes was developed at the University of Central Florida in the late 1980's (Taylor and Jacobs 1999). The permeate

concentration of a membrane processes can be predicted using several key mass transfer and membrane parameters, and is useful for determining post-treatment requirements. There are many different theories and models describing mass transfer in diffusion controlled membrane processes, however a few basic principles or theories are used to develop most of these models. A basic element flow and mass transport balance diagram in a synthetic membrane shown in Figure 1.4.

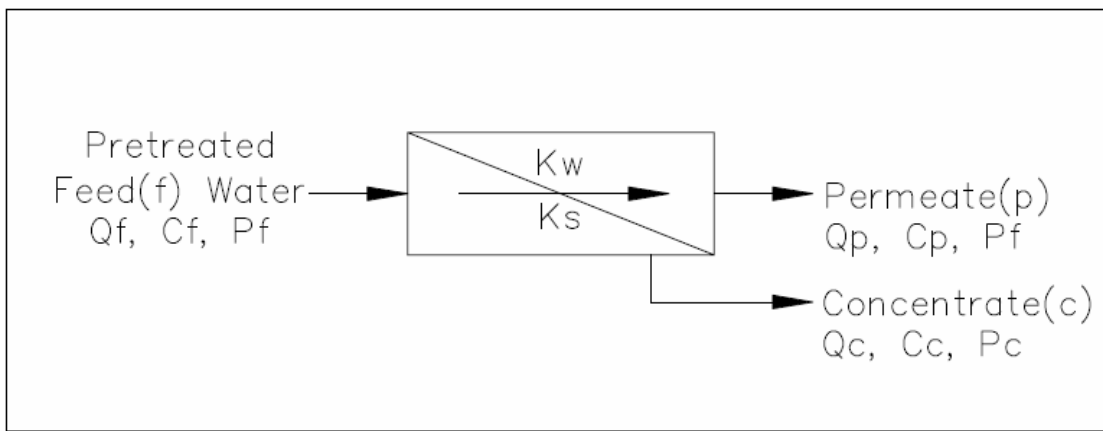

Figure 1-3: Basic Diagram of Mass Transport in a Membrane

The basic Equations used based on the homogeneous solution diffusion model (HSD) are shown in Equations (1.6) through (1.10).

$$J = k_w(\Delta P - \Delta \Pi) = \frac{Q_p}{A} \quad (1.6)$$

$$J_i = k_i \Delta C = \frac{Q_p c_p}{A} \quad (1.7)$$

$$r = \frac{Q_p}{Q_f} \quad (1.8)$$

$$Q_f = Q_c + Q_p \quad (1.9)$$

$$Q_f C_f = Q_c C_c + Q_p C_p \quad (1.10)$$

Where:

$J$  = Water flux ( $L^3/L^2t$ )

$J_i$  = Solute flux ( $M/L^2t$ )

$k_w$  = Solvent mass transfer coefficient ( $L^2t/M$ )

$k_i$  = Solute mass transfer coefficient ( $L/t$ )

$\Delta P$  = Pressure gradient (L),  $((P_f+P_c)/2-P_p)$

$\Delta\pi$  = Osmotic pressure (L)

$\Delta C$  = Concentration gradient ( $M/L^3$ ),  $((C_f+C_c)/2-C_p)$

$Q_f$  = Feed stream flow ( $L^3/t$ )

$Q_c$  = Concentrate stream flow ( $L^3/t$ )

$Q_p$  = Permeate stream flow ( $L^3/t$ )

$C_f$  = Feed stream solute concentration ( $M/L^3$ )

$C_c$  = Concentrate stream solute concentration ( $M/L^3$ )

$C_p$  = Permeate stream solute concentration ( $M/L^3$ )

$r$  = Recovery

$A$  = Membrane area ( $L^2$ )

$Z$  = Combined mass transfer term

If  $\Delta C$  is defined as the difference of the average feed and brine stream concentrations and the permeate stream concentration, then Equation (1.11) can be derived from Equations (1.6) and (1.10) (Duranceau, Taylor, and Mulford 1992). This model can be described as a linear homogenous solution diffusion model in that it predicts solute flow is diffusion controlled and solvent flow is pressure (convection) controlled. Equation (1.6) can be simplified by including a  $Z$  term, which incorporates the effects of the mass transfer coefficients, pressure and recovery into a single term.

$$C_p = \frac{k_i C_f}{k_w (\Delta P - \Delta \pi) \left( \frac{2-2r}{2-r} \right) + k_i} = Z_i C_f \quad (1.11)$$

Although this is a simple model, it does allow the effect of five independent variables on permeate water quality to be considered. If pressure is increased and all other variables are held

constant then permeate concentration will decrease. If recovery is increased and all other variables are held constant, then permeate concentration will increase. These effects may be difficult to implement if an existing membrane array is considered, for it is not possible to increase recovery without increasing the permeate concentration in such an environment. However, it is possible to increase pressure without varying recovery when arrays are designed. Different membranes may have different mass transfer characteristics. Using a membrane with a lower molecular weight cutoff would decrease the permeate concentration, although the solvent and solute mass transfer coefficients (MTCs) would need to be considered before such a result could be obtained.

The diffusion-based model represented by Equation (1.11) can be modified by the incorporation of film theory. Film theory assumes that the solute concentration exponentially increases from the center of the feed stream channel towards the surface of the membrane and diffuses back into the bulk stream, and can be modeled with the development of the homogenous solution diffusion model using concentration polarization. This model predicts that concentration at the membrane surface is higher than in the bulk of the feed stream. Such effects are documented in the literature and the model shown in Equation (1.12) accounts for these phenomena.

$$C_p = \frac{C_f K_s e^{F_w/k}}{K_w (\Delta P - \Delta \Pi) \left( \frac{2-2R}{2-R} \right) + K_s e^{F_w/k}} \quad (1.12)$$

Using this approach, an integrated solution diffusion model can be developed for low-salinity RO and NF source waters based on the diffusion model. Recall as shown in Equation (1.13), the integrated solution diffusion model can be developed based on the diffusion model.

$$\Delta \pi = K_{TDS} * \Delta C_{TDS} \quad (1.13)$$

The concentration increment along the membrane channel is illustrated by finite units with respect to  $R$  (recovery) can be expressed as shown in Equation (1.14):

$$\frac{dC}{C} = \frac{F_w dR}{(F_w + K_s)(1-R)} \quad (1.14)$$

Recall that  $F_w$  and  $K_s$  are water flux and solute MTC, respectively. Water is driven through the membrane by pressure (convection), whereas mass transfer of most inorganic and some organic solutes are diffusion controlled. Consequently, a simplification using the average bulk pressure of inlet and outlet pressure was made for model development as data was taken full or pilot scale plants that utilized spiral wound membranes. The osmotic pressure in a low pressure NF or RO membrane permeate stream can be neglected since TDS in the permeate stream contributes very little to osmotic pressure for nanofiltration or RO for low-salinity water. The ratio of solutes in membrane bulk solution was assumed as fixed. Therefore, the water flux can be expressed as shown in Equation (1.15), where  $C$  is concentration of one specific component (e.g. sodium),  $k_1$  is the corresponding factor that relates  $C$  to osmotic pressure, and  $K_1 C$  represents the osmotic pressure at the feed stream as it passes across the membrane channel.

$$F_w = K_w (\Delta P - \Delta \pi) = K_w (\Delta P - K_1 C) \quad (1.15)$$

Combining Equation (1.14) with (1.15) provides the expression given in Equation (1.16):

$$\int_{C_{f0}}^{C_c} \frac{dC}{C} = \int_0^R \frac{[k_w (\Delta P - k_1 C)] dR}{\{[K_w (\Delta P - k_1 C)] = K_s\} (1-R)} \quad (1.16)$$

Integration under the boundary condition  $C$  from inlet  $C_{f0}$  to  $C_c$  as recovery increases from 0 at the inlet 0 to  $R$  at the outlet, results in Equation (1.17). A solute mass balance of the membrane system is shown in Equation (1.18).

$$\left(\frac{C_c}{C_{f0}}\right)^{\left(1 + \frac{K_s}{K_w \Delta P}\right)} \left(\frac{\Delta P - k_1 C_{f0}}{\Delta P - k_1 C_c}\right)^{\frac{K_s}{K_w \Delta P}} = \frac{1}{1-R} \quad (1.17)$$

$$C_c = \frac{C_{f0} - RC_p}{1 - R} \quad (1.18)$$

Incorporation of Equation (1.18) into Equation (1.17) results in Equation (1.19), which is rearranged into the final model or Equation (1.20), where  $\Delta\pi_{in}$  is bulk osmotic pressure at membrane inlet,  $\Delta\pi_{out}$  is bulk osmotic pressure at membrane outlet with  $k_2$  being defined as the osmotic pressure correcting coefficient.

$$\left( \frac{C_{f0} - RC_p}{C_{f0}(1 - R)} \right)^{\left( 1 + \frac{K_s}{K_w \Delta P} \right)} \left( \frac{\Delta P - k_1 C_{f0}}{\Delta P - k_1 C_c} \right)^{\frac{K_s}{K_w \Delta P}} = \frac{1}{1 - R} \quad (1.19)$$

and

$$C_p = \frac{C_f}{R} \left\{ 1 - [K_2(1 - R)]^{\frac{k_s}{k_w \Delta P + k_s}} \right\} \quad (1.20)$$

where:

$$k_2 = \left( \frac{\Delta P - k_1 C_c}{\Delta P - k_1 C_{f0}} = \frac{\Delta P - \Delta\pi_{out}}{\Delta P - \Delta\pi_{in}} \right) \quad (1.21)$$

Note that  $K_1 C_1$  is osmotic pressure as approximated by a TDS correlation to osmotic pressure. The model is shown in Equations (1.20) and (1.21), and incorporates a general osmotic pressure correction factor that was estimated using a TDS or conductivity relationship with osmotic pressure. A final model is shown in Equation (1.22) and uniquely predicts permeate stream concentration of diffusion controlled solutes using a continuous correction for osmotic pressure:

$$C_p = \frac{C_f}{R} \left\{ 1 - \left[ \frac{\Delta P - k_{TDS} * TDS_c}{\Delta P - k_{TDS} * TDS_f} (1 - R) \right]^{\frac{k_s}{k_w \Delta P + k_a}} \right\} \quad (1.22)$$

where:

$$k_{TDS} = 69 \text{ Pa}/(\text{mg/L TDS}), \text{ or } 0.01 \text{ psi}/(\text{mg/L TDS}), \text{ or determined experimentally.}$$



## CHAPTER TWO: LITERATURE REVIEW

### Permeate Post-treatment

#### *Introduction*

Desalination will result in the production of water containing low dissolved solids content that can and will cause corrosion, and may not be fit for consumption. Pure water is considered a reactive chemical. When air is dissolved in extremely pure water, the resultant solution is very corrosive. Water that contains little to no hardness would be considered unhealthy for potable use and water that contains no dissolved oxygen may be offensive and taste flat. Consequently, post-treatment of membrane desalinated water is required prior to storage and distribution for municipal water purveyors, and must include disinfection.

Treatment processes downstream of the synthetic membrane processes RO, NF or EDR facilities are referred to as post-treatment processes. The water produced from the RO, NF and EDR membranes used to desalt water supplies usually requires some form of post-treatment because the permeate water from these membrane technologies can be corrosive because they have been desalted and purified. The water produced by a membrane process will require additional treatment, which may consist of several difference unit operations, before it is suitable for potable water use (Taylor et al. 1989; Byrne 1995; Duranceau 2001).

#### *Permeate Conditioning and Blending*

A recent overview of the current state of 62 full-scale RO/NF plants conducted by Burbano and others (2007) for plants greater than one-million gallons per day of capacity, used for either seawater desalination, brackish water desalination (including ground water, surface water and

agricultural runoff), or wastewater reclamation provides an insight into post-treatment practices. All of the surveyed facilities reported using at least one post-treatment method for permeate conditioning and corrosion control. These included such methods as caustic addition (31%), blending with raw, semi-treated or finished water (29%), degasification/decarbonation (25%), and addition of corrosion inhibitor (14%). Most of the brackish water RO plants responding to the survey reported using degasification/decarbonation and caustic addition, with the majority blending permeate with groundwater. Permeate disinfection was reported to be used by 85% of the surveyed facilities that responded, most of which used chlorine. Other reported disinfection methods included the use of chloramines (24%) and ultraviolet irradiation (4%).

Desalinated waters are commonly blended with small volumes of more mineral-rich waters to improve their acceptability and particularly to reduce their aggressive attack on materials (World Health Organization 2004) [WHO]. Blended water should be fully potable; when seawater is used for blending purposes, the major ions added are sodium and chloride. This does not contribute to improving hardness or ion balance, and only small amount, no more than 3 percent, can be added without leading to problems of acceptability. Blended waters from coastal and estuarine areas may be more susceptible to contamination with petroleum hydrocarbons or algal toxins, which could give rise to taste and odor problems. Some ground waters or surface waters, after suitable treatment, may be employed for blending in higher proportions and may improve hardness and ion balance.

#### *Municipal Methods*

The choice and sequence of post-treatment operations are typically determined by regulatory requirements, which can impact the design of the system and finished water quality criteria. The need for post-treatment generally depends on several factors, which can be grouped into three general categories and are related to water quality:

- Chemical Stability
- Microbiological Stability
- Palatability and Customer Acceptability (color, odor, taste).

Post-treatment generally must address the aggressive nature (low pH) of the desalted water. Pretreatment conditions must also be evaluated when considering post-treatment to ascertain how pretreatment (such as acid addition) will affect desalted water quality. Post-treatment to supply drinking water commonly includes permeate water pH adjustment for corrosion control, and chemical addition for disinfection. Table 2-1 provides a listing of typical desalting process used for post-treatment, depending on water supply. For brackish ground water and surface water supplies, pH and alkalinity adjustment for stabilization, corrosion control, and disinfection are typically required. Seawater supplies may or may not require similar post-treatment, depending on whether or not the water is from an open intake or wells. In addition to chemical treatment, blending with raw, or other water supplies feeding the distribution system, can produce non-corrosive water. Many facilities pump desalinated water directly into the distribution system without being mixed or blended with other finished water supplies raising concerns regarding distribution system water quality (Fayad 1993; Imran, Dietz, Mutoti, Taylor, Randall, and Cooper 2005).

Table 2-1: Typical Post-treatment Processes Based on Supply Type

Supply Type	Membrane Process Type(s)	Examples of Applicable Post-treatment Processes
Seawater	RO	<ol style="list-style-type: none"> <li>1. Recarbonation.</li> <li>2. Lime addition.</li> <li>3. Calcite bed filtration.</li> <li>4. pH and/or alkalinity adjustment.</li> <li>5. Addition of corrosion inhibitors.</li> <li>6. Primary and secondary disinfection.</li> <li>7. Blending with fresh water supplies.</li> </ol>
Brackish Water (Surface)	RO, NF, EDR	<ol style="list-style-type: none"> <li>1. pH and/or alkalinity adjustment.</li> <li>2. Addition of corrosion inhibitors.</li> <li>3. Primary and secondary disinfection.</li> <li>4. Blending with fresh water supplies.</li> </ol>
Brackish Water (Ground)	RO, NF, EDR	<ol style="list-style-type: none"> <li>1. Decarbonation</li> <li>2. Hydrogen sulfide stripping.</li> <li>3. pH and/or alkalinity adjustment.</li> <li>4. Addition of corrosion inhibitors.</li> <li>5. Primary and secondary disinfection.</li> <li>6. Blending with fresh water supplies.</li> <li>7. Bypass blending with raw water supply.</li> </ol>
Fresh Water (Ground)	NF, EDR	<ol style="list-style-type: none"> <li>1. Decarbonation</li> <li>2. Hydrogen sulfide stripping.</li> <li>3. pH and/or alkalinity adjustment.</li> <li>4. Addition of corrosion inhibitors.</li> <li>5. Primary and secondary disinfection.</li> <li>6. Blending with fresh water supplies.</li> <li>7. Bypass blending with raw water supply.</li> </ol>

Non-aggressive water can be produced by the addition of alkaline chemicals, and in some cases other chemicals, or blending with raw or other water supplies that may also feed the distribution system. Often corrosion inhibitors are added to further reduce the corrosion potential of the finished water. Seawater desalting post-treatment will often rely on a lime contactor for stabilization particularly if blending is not available on-site. The addition of lime is exothermic, and post-stabilization deposition may occur downstream of the lime contactor if dosage controls are not diligently maintained. Furthermore, the addition of lime other than a food-grade quality can impart turbidity to the downstream distributed water. Several chemicals may be added to the finished water

to increase pH, bicarbonate alkalinity or dissolved inorganic carbon (DIC), calcium, and orthophosphate (phosphate alkalinity). Lime (calcium hydroxide), soda ash (sodium carbonate), calcium chloride, sodium bicarbonate, caustic soda (sodium hydroxide), blending or zinc orthophosphates can be used for post-treatment. However, many of these chemicals, such as lime, calcium chloride, sodium bicarbonate are shipped as a dry chemical, which requires operators to prepare chemical feedstock solutions prior to use. The use of dry chemical feed systems has several disadvantages (Bergman and Elarde 2005):

- Storage and handling equipment requirements are increased
- Operation and maintenance requirements are increased
- Incomplete mixing and/or impurities (fillers) in the dry chemicals will add turbidity

Consequently, the use of gas and liquid supplied chemicals for post-treatment pH, alkalinity and corrosion inhibitor addition are often employed at desalting facilities. Carbon dioxide, sodium hydroxide, and phosphate-based corrosion control inhibitors are widely used in the United States for ease of use and delivery, unless hardness addition is required.

### Water Quality Considerations

Desalinated water often contains lower than usual concentrations of other ions commonly found in water, some of which are essential elements. Water typically contributes a small portion of these, and most dietary intake is through food. Exceptions include fluoride, and declining dental health has been reported from populations consuming desalinated water with very low fluoride content where there is a moderate to high risk of dental caries (WHO 2003b).

Concern has also recently been expressed about the impact of extreme major ion composition or ratios for human health. There is limited evidence to describe the health risk associated with long-term consumption of such water, although mineral content may be augmented

by stabilization processes typically used by utilities practicing desalination (WHO 2003b). Seawater is rich in ions such as sodium, chloride, magnesium, calcium, bromide and iodide, but low in some essential ions like zinc, copper, chromium and manganese.

### *Water Quality Parameters and Stability*

Permeate streams from seawater and brackish water desalting processes are primarily a dilute solution of sodium chloride. To provide stability to water, and to prevent corrosion (metal release) of piping systems and domestic plumbing, post-treatment is necessary to return some calcium hardness and bicarbonate alkalinity to the water. In many situations, post-treatment also includes the removal of carbon dioxide to raise the pH, hydrogen sulfide removal when required, and the addition of fluoride, which is removed during the desalting process.

As a result, corrosion control is one of the greater priorities when either directly pumping desalted finished waters into the distribution system or when blending different water sources from membrane process. The constituents of concern when establishing a post-treatment process include the pH, which will be dependent upon the buffering capacity and bicarbonate alkalinity, calcium, sulfate and chloride, dissolved oxygen, boron, total dissolved solids concentration and corrosion indices. These parameters are interrelated in the final treatment process selected for post-treatment, depending on application and source water (i.e. ocean surface versus brackish ground water supplies).

### pH

Various studies have been done to correlate the effect of pH on corrosion in pipes. The pH in a system is directly related to the alkalinity,  $\text{Ca}^{2+}$ , and CCPP in the system. Lahav and Birnhack (2007) stated that the pH determines the buffer capacity of the water sources. When different water

sources are blended, the chemical stability of the blend is significantly determined by the buffering capacity of the original waters. A higher pH will usually result in a lower buffer capacity, noted to be associated with low corrosion rates and prevention of red water episodes; however, most studies have shown pH to be an isolated single parameter. Lahav and Birnhack (2007) states that Imran did a study that showed that pH has no effect on the rate of corrosion or on the rate of iron release to the water as long as the water was supersaturated  $LSI > 0$  for the pH range  $7.8 < pH < 8.4$ .

The use of Langelier Index to support a determination of corrosiveness is not widely used. According to McNeill and Edwards (2001), the Langelier index has been improperly applied as a cure-all method for solving corrosion problems since it was first proposed in 1936 and it should not be singularly relied upon as a method for controlling internal corrosion. Although this method is successful at some utilities, it was by no means a method for controlling corrosion. As noted by McNeill and Edwards (2001) the AWWA manual on corrosion states, “*In light of much empirical contradicting of the presumed connection between the LSI and corrosion the practice should be abandoned*”. However, despite the criticisms offered by McNeill and Edwards (2001), and others it is fact that most, if not all, regulatory agencies within the USA require water purveyors to monitor, document and report the LSI on water purveyor monthly operating reports, particularly where advanced processes are used in part or entirely for treatment, and are deemed important with regards to utility administrator decision-making and regulatory monitoring purposes. In addition, the LSI is used to meet desalted water post-treatment goals according to the Gulf Drinking Water Quality Standards (GDWQS 1993).

## Alkalinity

Alkalinity in water is a measure of the general buffering capacity or stability of the water. Increasing the alkalinity generally leads to lower corrosion rate and results in fewer changes in pH of distributed water; however, excess alkalinity can cause excessive scale deposition where calcium may be present. Alkalinity is thus directly related to the buffering capacity of water, is considered an important parameter affecting the pH, and is shown in Equation (2.1).

$$\text{Alkalinity} = 2[\text{CO}_3^{2-}] + [\text{HCO}_3^-] + [\text{OH}^-] - [\text{H}^+] \quad (2.1)$$

Alkalinity depends on the concentration of bicarbonate, carbonate, and hydroxide ions in water. According to Lahav and Birnhack (2007) for a given pH value, the higher the alkalinity value, the higher the ability of the water to withstand a change in pH due to release of  $\text{H}^+$  and  $\text{OH}^-$  ions to the water. A higher alkalinity at a given pH translates into a higher dissolved inorganic carbon (DIC) concentration of the carbonate species ( $\text{CO}_3^{2-}$ ). However, too high of an alkalinity at higher pH levels may accelerate lead and copper metal release (Duranceau et al. 2004c; Taylor et al. 2005).

It is also known that red water prevention can be accomplished by maintaining the alkalinity in the system when considering a subsequent pH shift if treatment was to be employed. Non-stabilized finished water can experience fluctuations in pH in the distribution system, as scale is deposited (scale) or dissolved (corrosion), particularly when taking into account disinfection where chlorine may be present to react with the constituents in the water and infrastructure. It is desirable to maintain the alkalinity concentration in distributed water above one to one and one-half milliequivalent of alkalinity, or 30 to 60 mg/L (as calcium carbonate). Maintaining a moderate alkalinity is important in treated water with a negative saturation index as described by corrosion indices discussed herein.



While hydroxide alkalinity will increase the finished water pH, non-carbonate alkalinity, carbonate and bicarbonate alkalinity are still required to produce a Calcium Carbonate Precipitation Potential within a desired range of values in order provide adequate buffering capacity, and prevent pH variations within the system. Post-treatment methods used to recover or increase alkalinity in desalinate permeate include:

- Addition of caustic soda or lime to permeate containing carbonic acid
- Addition of carbonic acid followed by the addition of caustic soda or lime
- Addition of sodium carbonate
- Calcium carbonate through the use of limestone contactors

### Hardness

Calcium and magnesium are important minerals necessary for human health, and are important with respect to calcium carbonate film deposition on internal piping surfaces that comprise the water distribution system. Blending of native water supplies or bypass blending of raw water supply around the membrane process can assist in increasing the hardness of permeate; however, when chloride or sodium concentrations are high in the raw or native blend water, the ability to blend is limited. Slaked lime is often added to desalted seawater permeate to provide calcium and alkalinity in the form of hydroxide, in addition to providing pH adjustment. If lime is used for post-treatment to increase hardness, recarbonation may also be required to fully dissolve residual lime. Post-deposition of lime in downstream appurtenances is possible and must be monitored. Although limestone filters of 8 to 12 foot bed depth have been suggested for permeate post-treatment, they have been limited in use in the United States and are more often encountered in

Europe, the Pacific Rim, and the Middle East, often in conjunction with carbonic acid addition (American Water Works Association 2007)[AWWA].

### Dissolved Oxygen

The oxygen concentration of water can have varying effects on iron corrosion. The corrosion rate increases with increasing dissolved oxygen. Low dissolved oxygen can result in anaerobic microbial processes in service lines, resulting in offensive odors. Perceived “flatness” of water has also been associated with low dissolved oxygen levels. Dissolved oxygen is also responsible for the ability of buffering ions, including phosphates to inhibit corrosion (McNeill and Edwards 2001). White water complaints can occur when water is saturated with dissolved oxygen within the water column under pressure, and will manifest itself when released from the faucet.

### Brackish Water Post-treatment Considerations

With regards to ground water RO and NF supplies that are typically anaerobic, entrained gases such as carbon dioxide, hydrogen sulfide and methane (if present) are removed downstream of the membrane process before final pH adjustment and disinfection (Duranceau 2001). Removal of these gases is normally accomplished by stripping in a forced-draft packed column. In the most cases, carbon dioxide must be removed to stabilize the RO product water. If hydrogen sulfide is present, air stripping of the product water is usually done to control odor and minimize the amount of disinfectant (e.g., chlorine). The final product-water pH is often adjusted by caustic soda, soda ash, or lime.

As a result, the primary desalination water plant post-treatment unit operations for potable water supplies reliant upon brackish ground water are the following (AWWA 2007; Duranceau 1993):

1. Carbon dioxide removal (degasification or decarbonation);
2. Hydrogen sulfide removal (stripping) and odor control treatment (scrubbing);
3. Alkalinity recovery, pH adjustment, stabilization and corrosion control;
4. Disinfection

### Decarbonation

Dissolved carbon dioxide (or "free CO<sub>2</sub>") exists naturally in many water sources, particularly in ground water. Free carbon dioxide puts an ionic load stress on ion removal methods such as anion resin beds, continuous deionization (CDI) systems, and can internal corrosion within metallic distribution systems if not properly treated.

Carbon dioxide, along with nitrogen and oxygen, comprise the majority of atmospheric gasses. Water contains these gases in solution, following Henry's Law of gas solubility that defines a proportional relationship between the amount of a gas in a solution and its partial pressure in the atmosphere. Carbon dioxide, however, is an exception to Henry's Law because it reacts with the water to form carbonic acid, which then ionizes into hydrogen and bicarbonate ions. Since the bicarbonate ions are not subject to Henry's Law, only a small amount of it can be released by aeration.

Carbon dioxide is easily removed from brackish permeate water with the use of aeration, often referred to as degasification or decarbonation. The pH of the permeate water will determine the amount of carbon dioxide available to be removed from the water, as shown in Figure 1-5. The pH of the water affects equilibrium between bicarbonate ions and carbon dioxide. At a pH below

approximately 4.5, all of the carbon dioxide dissolved in the water is present as a gas. At a pH of about 8.5, all the carbon dioxide is ionized. For this reason, decarbonation by air stripping is only effective at low pH with the pH reduction resulting from prior process or acid addition. Carbon dioxide exists in equilibrium with other carbonate species as defined by the Equations (2.2) through (2.4):

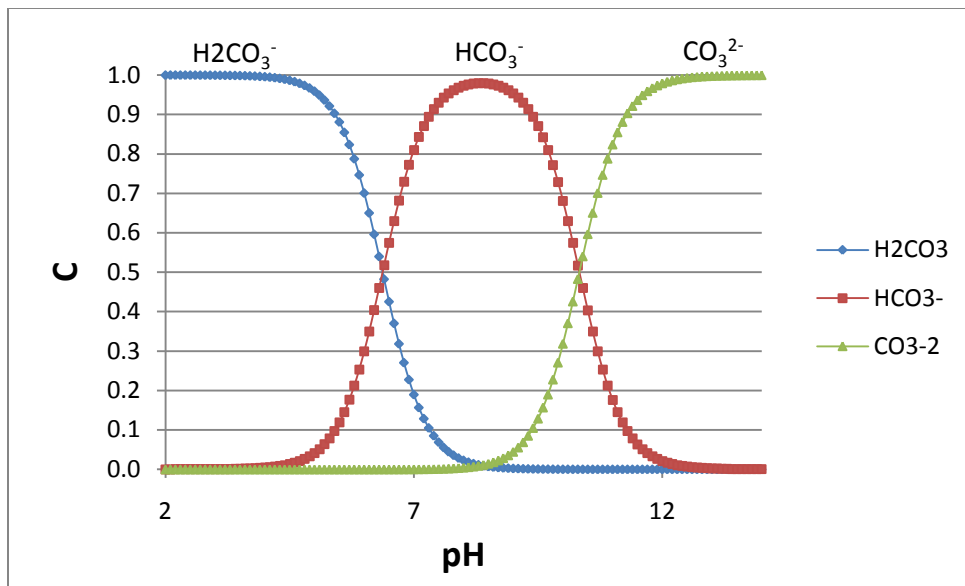
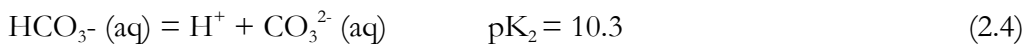
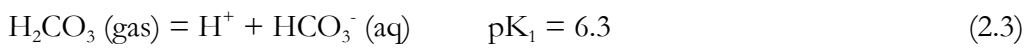
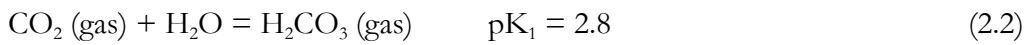
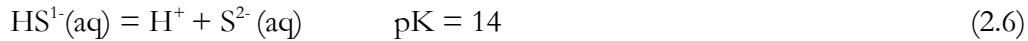

Figure 2-1: Effect of pH on Carbon Dioxide Concentration as a Fraction of Concentration

### Hydrogen Sulfide Stripping

Many of the brackish ground waters used as feed streams to RO or NF plants contain hydrogen sulfide. Hydrogen sulfide dissociates in water according to Equations (2.5) through (2.6):



Conventional pretreatment (acid addition, scale inhibitors, cartridge filtration) will not remove hydrogen sulfide nor will the membrane process, and hydrogen sulfide will permeate the membrane as a gas. Aeration and oxidation are the two primary means for removing hydrogen sulfide; incomplete chemical reactions in the process are often responsible for formation of polysulfide complexes and elemental sulfur, which manifest themselves as turbidity in the finished water (Lyn and Taylor 1993). As shown in Equation 2.5 and represented in Figure 1.6, since at pH of 7 only 50 percent of hydrogen sulfide exists in the gas form and is available for stripping pH adjustment is normally used to improve removal efficiency. The pK for hydrogen sulfide is 7, such that hydrogen sulfide gas can be completely removed at pH values below 6.3 without the formation of turbidity (elemental sulfur). However, all of the carbon dioxide in the permeate water will also be removed.

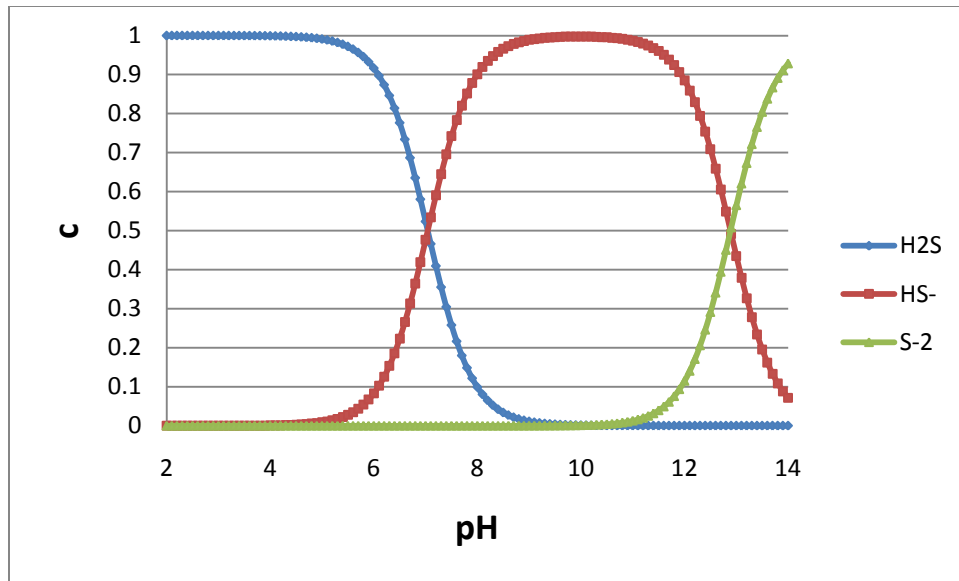

Figure 2-2: Effect of pH on Hydrogen Sulfide Species as a Fraction of Concentration

### Alkalinity Recovery and Bicarbonate Control

Utilities generally determines the composition of the product water and post-treatment is determined based on their regulatory and water quality standards. Problems that may occur within distribution system if water is not treated include corrosion within the pipes, which can lead to red water going to the consumers tap.

The alkalinity of water is a measure of its capacity to neutralize acids. Bicarbonates represent the major form of alkalinity in water, since they are formed in considerable amounts from the action of carbon dioxide upon basic materials in the soil. Stabilizing membrane produced water so that corrosion problem do not occur within the distribution system include pH and alkalinity adjustments, and the used of corrosion inhibitors. Blending waters are also used to lower the effect of adding desalted water directly in to distribution system. Alkalinity and pH control are considered as well as disinfection of the blended water.

Temperature, pH, and the concentration of bicarbonate are important in the formation of calcium carbonate in feed water as shown in Equation (2.7) below:

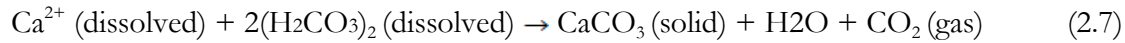

Unless carbonate is added or a significant amount of alkalinity passes the membrane, there will be no carbonate (alkalinity) buffering in permeate, a possible problem with respect to stabilization and corrosion control even if pH adjustment with sodium hydroxide is practiced. However, it is common practice in brackish water desalting to adjust the pH of the permeated water with sodium hydroxide and include the addition of a corrosion control chemical, typically a blended or zinc orthophosphate-type chemical.

If the desalination facility is treating brackish ground water supplies, Better methods are required to resolve this common post-treatment issue concerning alkalinity adjustment: An increase in the pH entering the tower prior to air stripping to recover 1 to 2 meq/L of alkalinity would be beneficial. However many facilities will not provide additional unit operations between the membrane process and the air stripper process. The use of carbonic acid pH adjustment prior to air stripping of hydrogen sulfide has proven beneficial with regards to buffering loss of finished water (Duranceau 1999a; Lovins, Duranceau, King, and Medeiros 2004a).

### Disinfection

Post-treatment disinfection is normally accomplished with chlorine, used a primary disinfectant. However, chloramines, ozone, and chlorine dioxide can also be employed to serve as chemical disinfectants in water treatment to inactivate pathogens, viruses, coli-form, and bio-film. An unintentional use of chemical disinfection in water treatment is the formation of chlorinated disinfection by-products (DBPs), potential carcinogens and a matter of public concern (Rook 1997;

Sittig 1985; USEPA 2007); in addition, brominated and iodinated DBPs have been identified in water distribution systems (Krasner et al., 1989; Hua, Reckhow, and Kim 2006).

As in conventional treatment, disinfection is required, but the chlorine demand is greatly reduced by the desalting process, resulting in minimal formation of disinfection byproducts (Taylor et al. 1989). However, if the desalting process allows the blending or bypass of water that contains disinfection byproduct (DBP) precursors, then chloramines, or some additional post-treatment of the blended water (or a reduction in the quantity bypassed or blended) may be required to comply with DBP drinking-water quality standards. The target levels of inactivation for pathogens remaining in desalinated waters can readily be achieved by appropriate disinfection processes.

Chlorine and the corresponding base can be simultaneously applied to the permeate stream following alkalinity recovery (Taylor and Durand, 1990). If chlorine has been used for sulfide removal and excess chlorine has been used some disinfection may have been accomplished; however chlorine will react preferentially with sulfides and not form any free chlorine until the sulfide demand has been exceeded (Lyn & Taylor, 1993). If chlorine and a base are added to the process stream before aeration, disinfection, oxygen addition and stabilization will occur.

#### Seawater Post-treatment Considerations

The untreated permeate from seawater desalting facilities are highly aggressive and corrosive to water distribution components, pipeline systems, storage facilities and appurtenances. There are many different methods available for increasing the mineral and buffering content of desalinated seawater in an effort to produce buffered water having a stable pH value with a slightly positive LSI (Withers 2005). Lime or limestone filtration and carbon dioxide polishing (to achieve permeate water quality goals) are often employed throughout the world to recarbonate desalted seawater supplies. However, the use of hydrated lime can result in excessive formation of finished water



turbidity, which may impact compliance with the SDWA Surface Water Treatment Rules should the seawater facility be permitted as a surface water supply.

Furthermore, process control issues could arise if hydrated lime is used for permeate having such low buffering capacity, possibly resulting in variable pH and LSI entering the distribution system. The use of 3 percent lime slurry solution strength has been shown to be effective (Withers 2005). Should the seawater feed to the desalting process is acidified as a part of the pretreatment process, then carbon dioxide will exist in the permeate, assuming acid dosage was employed for calcium carbonate precipitation fouling control. Consequently, the selection of an appropriate desalted seawater post-treatment method, or methods, remains a site-specific consideration.

Alternative treatments reported for use in seawater desalination post-treatment applications include (Withers 2005):

1. Addition of carbon dioxide and excess lime;
2. Filtration of carbon dioxide dosed permeate through limestone bed contactors;
3. Application of sodium carbonate and hydrated lime;
4. Application of sodium bicarbonate and calcium sulfate;
5. Application of sodium bicarbonate and calcium chloride;
6. Blending with a native low-salinity water source or by-pass blending.

Re-mineralization can be categorized into a series of four treatment processes: (1) chemical addition without lime or limestone; (2) carbon dioxide addition followed by limestone bed contactors for dolomitic dissolution, (3) carbonic acid addition followed by lime dosing; blending with water containing high mineral content.

## Regulatory Considerations

There are many regulations that apply to potable water. A thorough understanding of the regulations governing the particular application is required before a post-treatment design can be performed. Continuing advances in regulatory mandates and increasing demands related to aesthetic criteria for consumer water quality have driven the water community to seek new water supplies and treatment technologies that meet SDWA criteria. Foremost among regulatory constraints are disinfection requirements, disinfection by-product formation, and corrosion control regulations. Consumers have become aware of regulatory violation through mandated public notification and Consumer Confidence Reports (CCR), and they have always been aware of the appearance, taste, and odor of drinking water. Increasing demands for additional water resources have required communities to seek alternative water supplies that may produce process streams that are not compatible with existing supplies. Potential water quality impacts of particular importance when addressing water quality compatibility involve: regulatory compliance; public health effects; the chemicals used to provide disinfection; and the factors affecting the corrosiveness of the water distributed to customers.

For example, desalination has to reduce typical seawater (approximately 32‰ salinity) to an acceptable drinking water standard of below 500 mg/L total dissolved solids. In addition, regulations corresponding to the water distribution system also need to be taken into account, and include the Lead and Copper Rule (LCR), Disinfectant/Disinfection By-Products Rule (D/DBP), and Total Coliform Rule (TCR).

Evaluation of corrosion control is not as straightforward for lead and copper control at consumer taps as there are other regulated mandates other than the LCR, such as the D/DBP (organics) and TCR (disinfection) that are occurring simultaneously, and the multitude of changes

that can occur in a water distribution system may mask any single change. Corrosion control is often implemented using chemical-type treatments based on dosing treatments within the treatment facility where the chemical feed systems rely on the use concentrated bulk chemical feed tanks. Locally the waters can be either corrosive or scaling, and as such, the distribution system is monitored by corrosion indices, the most common in use is the Langelier Saturation Index (LSI) despite the fact that recent work has shown that additional factors are more relevant to monitoring and maintaining corrosion control in a water system (Singley 1981).

Further, taste and odor concerns dominate the response of most water utilities to customer concerns, and although they are regulated as Secondary Contaminants per the SDWA, the taste and odor of permeate are for the most part subjective. Taste refers only to sensations typically referred to as bitter, salty, sour and sweet, and is dependent upon the chemical substances present (Mallevalle and Suffet 1987). Odor, like taste, depends on the chemical substances present in the water being consumed. Certain inorganic salts can produce tastes without odor, and as a result, permeate of desalinated water systems can appear to have a flat taste. If disinfectant is present, a perceived odor can also be noted. Customers have been known to register complaints to their water purveyor when a drastic change in water quality occurs, but will become accustomed to a new water quality given time, assuming the quality does not further change substantially (WHO 2004). Stabilization will reduce the perceived reactions to desalted permeate, in addition to providing its primary associated benefit related to addressing internal corrosion control concerns.

### Lead and Copper Rule

The Lead and Copper Rule (LCR) was promulgated by the USEPA on June 7, 1991 as a methodology to reduce lead and copper in drinking water. In the LCR, the USEPA has mandated that the most appropriate methods for reducing lead and copper are 1) water treatment for

corrosion control in the distribution and plumbing systems and removal of lead and copper from source water, 2) replacement of lead service lines, and 3) public education (AWWA 1992a). The control of internal corrosion within the distribution system in desalted and/or blended waters is imperative to maintain compliance with the LCR and provide acceptable consumer confidence.

The major source of lead in drinking water is typically not the source water, but the corrosive action of the water on materials in plumbing systems. Newly installed tin-lead-soldered copper piping is often found to release appreciable amounts of lead into the drinking water plumbing system, and gradually decreases as the internal surfaces of the pipe age with time. Corrosion control measures acceptable to reduce lead and copper at the customer's tap under LCR are water chemistry control or use of corrosion inhibitors in the water treatment. Chemical control is typically accomplished via either/or pH adjustments using sodium hydroxide or other base, addition of alkalinity using calcium carbonate or soda ash, or use of inhibitors. Phosphate and silicate based corrosion inhibitors can also be used for corrosion control (AWWA 1992b).

From LCR monitoring studies (AWWA 1992a), optimal corrosion control water parameters (pH, calcium, alkalinity, conductivity, temperature, corrosion inhibitor concentration) are determined and the operating point for the water system is set. Permeate water without treatment can and will affect compliance with the LCR such that stabilization and treatment for corrosion control is required (Duranceau 2004b). Internal corrosion is a complex electrochemical phenomenon that cannot be eliminated, but can be controlled in a cost-effective manner. The most prominent corrosion by-products in drinking water are lead and copper. While iron oxides are the major corrosion by-products, lead and copper are the by-products of major concern; corrosion control strategies aim to limit lead and copper, the corrosion by-products of major concern, in drinking

water. The water velocity, residence time, temperature, and water quality (pH, hardness, alkalinity, and dissolved oxygen) can affect corrosion rates of common plumbing systems.

Few studies are available that demonstrate the direct impact of membrane permeate on compliance with the LCR. However, membrane softening processes have been shown to reduce the propensity of copper and lead metal release as compared to traditional water treatment for ground water supplies. Duranceau (1999b) showed that the implementation of a membrane softening facility for a groundwater supply in Dunedin, Florida resolved total trihalomethane issues as well as aid in the reduction of copper content in consumer taps.

### Disinfection

Post-treatment disinfection is required in the United States and is normally accomplished with chlorine. The Total Coliform Rule (TCR) is the primary regulatory vehicle for monitoring the microbial stability of a distributed water and presence of potential pathogens by monitoring for TC as a surrogate of pathogen intrusion. In addition, application of chloramines to desalinated waters having higher levels of bromide can result in the rapid loss of disinfectant residual in water conveyance systems (Agus 2009).

Desalinated waters present a relatively easy disinfection challenge because of their low TOC and particle content, low microbial loads and minimal oxidant demand after desalination treatments. Turbidity is not likely to affect chemical disinfectant performance since turbidity values of desalinated water are relatively low. Post-treatment with lime can cause an increase of inorganic turbidity that would not interfere with disinfection; use of food-grade lime aids to limit the amount of inorganic turbidity imparted to the water.

Almost no chlorine demand will remain following a reverse osmosis or nanofiltration process. The chlorine will convert some of the recovered alkalinity to carbon dioxide, which will be

lost during aeration; however, the pH should return to the stabilization pH, as carbon dioxide will tend to be at equilibrium with the atmospheric carbon dioxide. The pH will closely approach pHs with respect to calcium carbonate. The basic Equations (2.8) to (2.12) are shown below:



$$\text{pH} = \text{p}K_{\text{H}_2\text{CO}_3} + \text{Log} \left| \frac{\text{HCO}_3^- (1 + \alpha_{\text{OCl}^-}) C_{T\text{Cl}_2}}{\text{H}_2\text{CO}_3 + (1 + \alpha_{\text{OCl}^-}) C_{T\text{Cl}_2}} \right| \quad (2.11)$$

$$\text{OH}^- \text{ addition} = \text{OH}^- \frac{\text{mg}}{\text{meq}} \left| \frac{\text{meq}}{\text{mmol}} \right| C_{T\text{Cl}_2} |1 + \alpha_{\text{OCl}^-}| \quad (2.12)$$

Chlorine addition to water will produce equal moles of hypochlorous acid and hydrochloric acid. The hypochlorous acid will partially ionize to hypochlorite ions as protons. The hydrochloric acid will completely ionize producing protons and chloride ions. One mole of protons will be produced for every mole of hydrochloric acid and every mole of hypochlorite ion produced. Consequently, the complete proton production during chlorination would be canceled by the addition of OH<sup>-</sup> as shown above. Unlike seawater desalination which may require 1 to 2 mg/L of chlorine for disinfection, typical chlorine doses following a membrane softening nanofiltration process could range from 5 to 7 mg/L, and is dependent upon several factors including chlorine demand, bromide and TOC concentration, pH, temperature and dosage rate (Taylor et al. 1989).

Calcium deposition at injection points can result from poor design or installation, so one needs to make sure that chemical injection quills reach far enough into the flow for effective

dilution, and that the materials of construction that are specified can handle forces of velocity, are hydraulically and chemically resistant.

### Disinfection By-Products

Chlorination is the most common disinfectant in current use for post-treatment of desalinated permeate, followed by either chloramines or chlorine dioxide unit operations. When brackish water or seawater permeate is chlorinated, bromoform and brominated haloacetic acids have been determine to be present (Agus et al. 2009). Less information is available of other halo-organic DBPs in desalination plants. DBPs identified in desalted permeate water include haloacetonitriles, mutagen X compounds, halonitromethanes, and cyanogen bromide pose potential concern, especially when desalinated waters are blended with native water having high disinfection by-product precursors present. Elevated concentrations of bromide can lead to the production of brominated DBPs when chlorine (Krasner et al. 1996) or ozone (Haag and Hoige 1983) is used as a disinfectant. Brominated and iodinated DBPs have also been detected in the permeate of desalination facilities and its blends, and is a subject of much research (Richardson et al. 2003).

### Distribution Systems and Internal Corrosion Control

#### *An Overview of the causes of Internal Corrosion*

Corrosive water generally produces elevated levels of copper and lead at the tap. Studies indicate that the highest levels of copper and lead occur in the first draw tap samples from single-family residential structures with interior plumbing of lead soldered copper pipes installed after 1982 (USEPA 1991). Factors affecting the concentrations of lead and copper in the samples include the standing time of the water in the pipes, the type of solder used for the joints, and the quality of the

plumbing installation. Other minor constituents imparted to the water are zinc and manganese, which are present in most consumer interior plumbing systems.

The primary means of regulating copper and lead is by eliminating the electrochemical potential connection between the metal surface and water column. While it is true that the USEPA requires solder to be lead free (less than 0.17 percent Pb), most system corrections involve disrupting the electrical connection. Internal corrosion of the distribution system piping deteriorates the quality of the potable water. Typically, this results in rusty water conditions, low chlorine residuals, bacterial regrowth, and an increase in copper and lead concentrations.

Severe corrosion can cause tubercle formation, significant loss of hydraulic capacity, and eventually, pipe failure. Internal corrosion, in a distribution system with different types of pipe materials, is site specific. The primary interrelated factors that affect internal corrosion are:

- Flow velocity
- Workmanship and flux corrosion
- Galvanic corrosion
- Microbial induced corrosion
- Chemical factors (water quality)
- Stray current
- Temperature

Water quality characteristics in the distribution system are a function of the raw water supply and the processes that are used for treatment. Major water quality factors affecting internal corrosion include pH, conductivity, total dissolved solids, hardness, alkalinity, dissolved oxygen, chlorine residual, sulfate and chloride.



According to USEPA, corrosion causes the deterioration of crystalline structures that form the pipe materials, and can occur by one of the following three principle mechanisms:

1. Dissolution
2. Abrasion
3. Metabolic activity

Dissolution is a thermodynamic process where the solution is driven to equilibrium resulting from concentration gradients. Dissolved oxygen, pH, alkalinity, calcium, suspended solids, organic matter, buffer intensity, total salt concentration, chloride, sulfate, phosphate, and silicate have shown to have different effects on the corrosion of different metals. The dissolution or corrosion of pipe materials occurs when water chemistry and physical conditions generate the following corrosion mechanisms.

- Uniform corrosion - when the water freely dissolves metal from the pipe surface.
- Concentration cell corrosion - when anodic and cathodic points are established along the pipe surface, causing the sacrifice of metals at the anode (dissolved metal species) and the precipitation of less soluble metal compounds at the cathode.
- Galvanic corrosion - when two dissimilar metals are in contact with each other, causing the dissolution of the anode.
- Dezincification corrosion – occurring in a copper-zinc alloy, such as brass, is the result of zinc being more anodic than copper and being corroded in water, leaving the copper in situ. Yellow brass is subject to severe dezincification in soft, non-stabilized waters; however, red brass and Admiralty brass metal containing less zinc are much less subject to this type of corrosion.

Some of the primary constituents in the water that promote and support pitting attack are dissolved carbon dioxide and dissolved oxygen (Cohen and Meyers 1987). Oxygen is usually present when corrosion occurs, and carbon dioxide is present at low pH values. Unlike generalized corrosion, pitting is associated with hard waters having high carbon dioxide and dissolved oxygen content, and most often occurs in cold-water copper piping in the horizontal runs of piping. Pitting has also been associated with stray current and impingement attack by high water velocities of copper. However, pitting attack is most common in new installations, with 80 to 90 percent of the reported failures occurring in the first 2 to 3 years, after which incidence of pitting is reduced (Schock 1990).

Abrasion is the physical removal of pipe material due to irregularities in the pipe surface, which may dislodge under high fluid velocities. Abrasion of piping materials is typically accelerated when corrosion by-products, such as tubercles, are present in the distribution system. Abrasion activity normally diminishes when tubercles are reduced or if the tubercles can be coated with a less permeable substance. This effect has been noted by several full-scale systems, which have reported fewer customer complaints about red or black water events after corrosion control treatment was implemented (USEPA 1992). There is a difference in the chemistry of corrosion control between flowing and standing conditions. This variation was evidenced by fluctuations in pH and increases in alkalinity for standing water compared with flowing water (Johnson et. al. 1994).

Metabolic activity is the utilization of pipe materials as a nutrient supply by microorganisms. Implementing corrosion control will alter the finished water chemistry, which subsequently may influence microbial growths within the distribution system. Recent studies have shown that bio-films are strongly associated with corrosion by-products within distribution systems. This association

makes the bio-films more resistant to disinfection, and therefore, more persistent when active corrosion takes place in distribution system piping.

While bio-film formation may be promoted by corrosion, it remains difficult to accurately quantify the effects of microbial activity and the effect of treatment on such activity. Some potable water systems have experienced increases in distribution system microbial growth when corrosion control treatment was implemented due to the addition of nutrients to the finished water. In particular, this may become a problem within distribution systems where chloramines are used for final disinfection and a phosphorous-based inhibitor is applied for corrosion control.

As chloramines are reduced during oxidation, ammonia is released into the water. Thus the presence of two major nutrients, nitrogen and phosphorous, could increase microbial growth. This is especially likely in the extremes of the distribution system where localized areas with inadequate disinfection may occur (USEPA 1992).

Certain qualities of RO permeate water can destroy certain types of piping materials, such as galvanized steel or asbestos-cement materials. Material selection for RO permeate is dependent on many design and site-specific criteria, such as water type. For examples, the use of piping materials constructed of polyvinylchloride (PVC) may be selected for use in NF and brackish RO permeate, and whereas 304L stainless could be selected for fresh water, 316L stainless should be considered for brackish water. Other possible options include the use of duplex stainless for brackish water and specific alloys (for example 6% Moly) for seawater applications. Table 2.2 summarizes a list of pipe materials and comments regarding corrosion. The chemical composition of permeate water produced by RO or NF when blended with other source water can cause water quality and infrastructure problems when distributed.

Table 2-2: Pipe Material and Corrosion

Pipe	Material Comment
Copper	Corrosion of galvanized pipes; corrosion of household plumbing systems; erosion of natural deposits; leaching from wood preservatives. In drinking water containing minerals and dissolved oxygen, corrosion rates are from 5 to 25 $\mu\text{m}/\text{yr}$ . In high purity water (very soft) protective films do not form on the internal copper surfaces and corrosion rates from 3 to 130 $\mu\text{m}/\text{yr}$ occur, increasing with increasing oxygen and carbon dioxide content. Low sulfide concentrations (as low as 10 ppb) can accelerate corrosion of copper alloys.
Lead	Corrosion of household plumbing system; residue from man-made pollution such as auto emissions and paint; lead pipe, casing and solder. Waters of alkalinity of 60 mg/L or below will generally be less corrosive to lead if the pH is 7.5 or above. Increased dissolved oxygen will generally be expected to cause increased corrosion of lead.
Cast Iron Pipe	Interior corrosion, formation of tubercles, most biofilm growth, used for service lines. Internal corrosion will depend on water hardness, alkalinity, chlorides, sulfates, silica, dissolved gases, pH, temperature and velocity. Graphitic corrosion and bacterial attack are common causes of fracture of cast iron water piping; graphite dispersed in cast iron serves as the cathode, and the iron-silicon alloy, the anode. This results in the dissolution of the iron alloy and leaves black soft graphite as a structurally deficient material.
Lead Pipe Joints	Water is naturally corrosive and can pick up microscopic amounts of lead if it sits idle for extended periods of time.
Ductile Iron Pipe	Arsenic, mercury, and <i>Bacillus subtilis</i> all strongly adhere to cement-lined ductile iron pipe. Ductile iron pipe is typically furnished with cement-mortar lining to prevent internal corrosion.
Steel Pipe	Used for service lines and taps; external corrosion can occur. Since pitting can be facilitated by the deposition of copper on zinc, galvanized steel should not be installed downstream of copper tubes and fittings. Stainless steel has good corrosion resistance to potable waters including soft (desalinated) supplies.
Plastic Pipe	Used for water supply piping, resistant to corrosion ; lower tendency for biofilm growth than metallic counterparts. Many varieties available; brittleness can be a problem. Leaching of chemical plasticizer residuals can occur internally.
Asbestos Cement	Asbestos-cement (AC) pipe has been widely used for potable water piping. Low pH, low alkalinity water are aggressive to AC pipes. Rates of deterioration can be reduced by chemical treatment to increase the water's buffer capacity but will not prevent the release of fibers from pipes that have already been degraded.

### *Indices for Predicting Corrosive and Scale Tendencies of a Water*

Several indices have been developed to indicate the stability or corrosiveness of potable water. Although no single index is definitive, and some may at times be misleading, potable water corrosiveness or scaling potential can be evaluated and determined with a combination of indices. Each index provides information on the nature of the potable water; however, many of the indexes found in the water treatment and corrosion control literature are only approximations.

#### Corrosion Indices

For the purposes of this evaluation, buffer intensity, the calcium saturation index (CSI), Langelier saturation index (LSI), calcium carbonate precipitation potential (CCPP), Casil Index, Larson Ratio, and Ryznar index are typically considered, and are described as follows:

- Buffer intensity - This index measures the ability of the potable water to resist changes in pH that are caused by the addition of acids and bases. The index is expressed as milli-equivalents or moles per liter of strong acid or base to change the pH by one unit. An index greater than 0.5 milli-equivalents per pH unit is desirable. Water with low buffer intensity is frequently more corrosive. Wide variations in pH throughout the distribution system are reflective of water with low buffer intensity. Bicarbonate and carbonates provide the buffering capacity as measured by the alkalinity of the water.
- Langelier saturation index (LSI) - This index predicts whether a thin film of calcium carbonate is being formed on the walls. If the LSI is greater than zero, the water is considered scale forming, that is supersaturated with calcium carbonate. Waters with a LSI greater than zero are considered non-corrosive. If the LSI is less than zero, then the water is under saturated with calcium carbonate and the water will potentially dissolve calcium

carbonate scales and would be considered corrosive. That is, a protective film of calcium carbonate will begin to dissolve into the potable water. The formula for the LSI is based on a comparison of the measured pH of specific water ( $pH_a$ ) with the pH that the water would have ( $pH_s$ ) if at saturation with calcium carbonate (calcite) given the same calcium hardness and alkalinity for pH cases. Pisigan and Singley (1984) reported that the LSI is not a reliable indicator of the corrosive tendencies of potable water and that empirically chloride, sulfate, alkalinity, dissolved oxygen, buffer capacity, calcium, LSI and length of time of exposure provide information that is more reliable. The basic formula for the LSI is shown in Equation (2.13):

$$LSI = pH_a - pH_s \quad (2.13)$$

- Calcium carbonate precipitation potential (CCPP) - This index is a refinement of the CSI and takes into consideration the capacity of the potable water to precipitate or dissolve calcium carbonate. The CCPP is a function of the calcium carbonate saturation. Reducing the pH and alkalinity increases the corrosion potential of the water. As noted in Lahav and Birnhack (2007), the calcium carbonate precipitation potential is a quantitative measure of the precise potential of a solution to precipitate or dissolve  $CaCO_3$ . It constitutes a parameter that can be used in the context of guidelines or regulations without invoking misunderstanding. In contrast to the Langelier, index which at times can be misguided. The CCPP, in contrast to the Langelier index, is easily understood in the context of guidelines and regulations. The precipitation of a thin layer of protective calcium carbonate (presumably calcite) was the earliest proposed method for controlling iron corrosion. However, few articles ever demonstrated a beneficial role of calcite in controlling corrosion as stated by McNeill and Edwards (2001). Systems that use CCPP or LSI, should use both,

as LSI can indicate the tendency to scale and CCCP can indicate how much scale will develop.

- Calcium saturation index (CSI) - This index is a function of the calcium carbonate saturation. Reducing the bicarbonate concentration and pH will decrease the CSI. Declining CSI indicates a more corrosive water or calcium carbonate under saturation.
- Casil index - This index is based on a cation/anion balance. With a decrease of cations, the index is smaller and indicates more corrosive conditions. A decrease in the pH can increase the concentration of anions and may result in a lower index. The impact of desalinated water on the occurrence of nitrification in the distribution system will be added to the survey parameters.
- Larson's ratio - This index is calculated from the relative ratio of the total of chloride and sulfate ions to the total alkalinity of the water. Reactive anions form strong acid in anodic pits that form in the exposed corroding metal. Bicarbonate and other weak acids can precipitate a protective film on the exposed metal pipe wall. Index values greater than 0.4 indicate more corrosive water; a value less than 0.2 indicate that water is relatively non-corrosive.
- Ryznar index – This index is similar to the LSI, and is calculated as  $RI = (2pH_s) - pH$  (Ryznar, 1944). The Ryznar index yields values below 6.0 if scaling tendency is indicated, and a tendency to dissolve calcium carbonate is indicated at values above 6.0. This index provides a reasonably good estimate of expected scale formation even in the presence of phosphate-based inhibitors.

### *Corrosion Indices and Boron*

Delion (2004) gauged the corrosivity of Mediterranean seawater, chosen as a representative of the Atlantic Ocean and Red Sea. There was 5.5 mg/l of total boron found in the sample when conditions were set for model of membranes, TFC, configuration, spiral wound, fouling factor of 0.85, net feed pressure at 65 bar and a recovery of 40%. Delion and others (2004) indicated that Leroy ratio and Larson ration Equations (2.14) and (2.15) respectively, should be used in order to check the corrosive potential of the water.

- Leroy Ratio:  $(TAC)/(TH)$  (2.14)

- Larson Ratio:  $([Cl^-] + 2 X [SO_4^{2-}])/([HCO_3^-])$  (2.15))

For low amount of corrosion, Larson's Ratio should be less than 1 and Leroy's Ratio should be between 0.7-1.3. For post-treatment, Delion and others (2004) focuses on three parameters, concentrations of chlorides, sodium and boron. Along with these three parameters, the mineralization, temperature and recovery must be specific; otherwise the result will not be favorable. Utilizing a membrane with a higher rejection level will aid in reducing the amount of boron in the water. Reducing recovery, increasing feed pressure and increasing pH also aid in removal

### Corrosion Control Strategies And Stabilization

#### *General Approaches*

Corrosion control strategies can be divided into two general approaches. The difference between these two approaches is the mechanism by which a protective film is formed. The first approach includes precipitate formation of protective coatings for corrosion control. Water chemistry is adjusted to cause the precipitation of a compound onto the pipe wall and form the



protective film. The success of this approach depends on the ability to form this precipitant and the characteristics of the deposits that result on the pipe walls.

The second approach involves the interaction of the potable water supply and the pipe material to form metal compounds that create a protective film of insoluble material for corrosion control. Passivation is the mechanism of this second approach. Adherence of the insoluble metal compound on the pipe wall determines the success of this approach. The primary option for corrosion control, particularly with respect to the LCR, includes (USEPA 2003):

- pH adjustment
- Bicarbonate stabilization (alkalinity adjustment)
- Calcium adjustment
- Inhibitor addition

In practice, there are a few typical methods employed for corrosion control treatment of desalted permeate. The corrosion control treatment strategies are evaluated in the following paragraphs.

### pH Adjustment

Adjustment of pH is used to induce the formation of insoluble compounds on the exposed pipe walls. Passivation is the operating mechanisms for this corrosion control strategy. pH adjustment is accomplished with the addition of chemicals, such as lime, soda ash, sodium hydroxide, potassium hydroxide and carbon dioxide. pH adjustment is most suitable for source waters with low to moderate hardness and alkalinity levels (between 80 and 150 mg/L as CaCO<sub>3</sub>). Frequently, this treatment technique is used in lieu of calcium carbonate precipitation. Some concerns with pH adjustment include higher trihalomethane formation potentials at pH at values

greater than 8.1, increased formation of other disinfection by-products at pH levels above 7.8, decreasing chloramines disinfection efficiency with pHs below 7.8, and a higher potential for calcium carbonate scaling in the distribution system pipe at pHs above 7.9.

#### Alkalinity Adjustment and Recovery

Alkalinity adjustment frequently is used to induce the formation of insoluble compounds on the pipe walls of the distribution system. Passivation is the operating mechanism for this corrosion control strategy. Carbonate passivation is achieved by incorporation of pipe materials into a metal hydroxide/carbonate protective film. This corrosion control strategy is most suitable for source waters with minimum alkalinity, and is frequently used in lieu of calcium carbonate precipitation. Alkalinity adjustment alters the concentration of dissolved inorganic carbonate (DIC) in the source water.

Alkalinity adjustment can be accomplished with lime, soda ash, sodium bicarbonate, sodium hydroxide, potassium hydroxide and carbon dioxide. Sodium bicarbonate addition is preferable for alkalinity adjustment. Sodium hydroxide contributes little alkalinity to the water, but can cause dramatic increases in pH. The primary disadvantages of alkalinity:

- Capital, and operation and maintenance cost
- Increased carbonate scaling on the pipe walls

The primary benefit of alkalinity adjustment is increasing the buffering capacity for the source water. This helps to prevent wide fluctuations in pH throughout the distribution system. A buffer intensity greater than 0.5 milli-equivalents per pH unit is indicative of a balanced, stabilized source water. The regional water appears to have adequate alkalinity and buffer intensity as long as the alkalinity is maintained at or above 100 mg/L as CaCO<sub>3</sub>.

For ground water treatment using RO and NF, the membrane is a closed system and the carbon dioxide will remain under pressure until exposed to an open system. Consequently, if acid addition is used for scaling control, the alkalinity in the raw water will be destroyed but not lost. Alkalinity recovery needs to be considered when selecting scaling control options, and depends on how much carbon dioxide and bicarbonate is in the raw water.

Carbon dioxide that is converted from bicarbonate ion during pretreatment or post-treatment will be available in a closed system. Consequently the desired carbonate alkalinity in the finished water can be attained by carbon dioxide conversion before aeration, given presence of adequate CO<sub>2</sub>. Normally, finished waters with 1 to 3 meq/L of bicarbonate alkalinity are considered highly desirable for corrosion control. Since carbon dioxide will pass unhindered through the membrane the desired amount of alkalinity can be recovered in the permeate by acidifying the desired amount, passing it through the membrane and adding the desired amount of base to convert the carbon dioxide back to its original bicarbonate form.

The reactions are shown in Equations (2.16) and (2.17), and alkalinity recovery is show as a process flow in Figure 2.1.

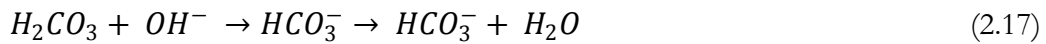

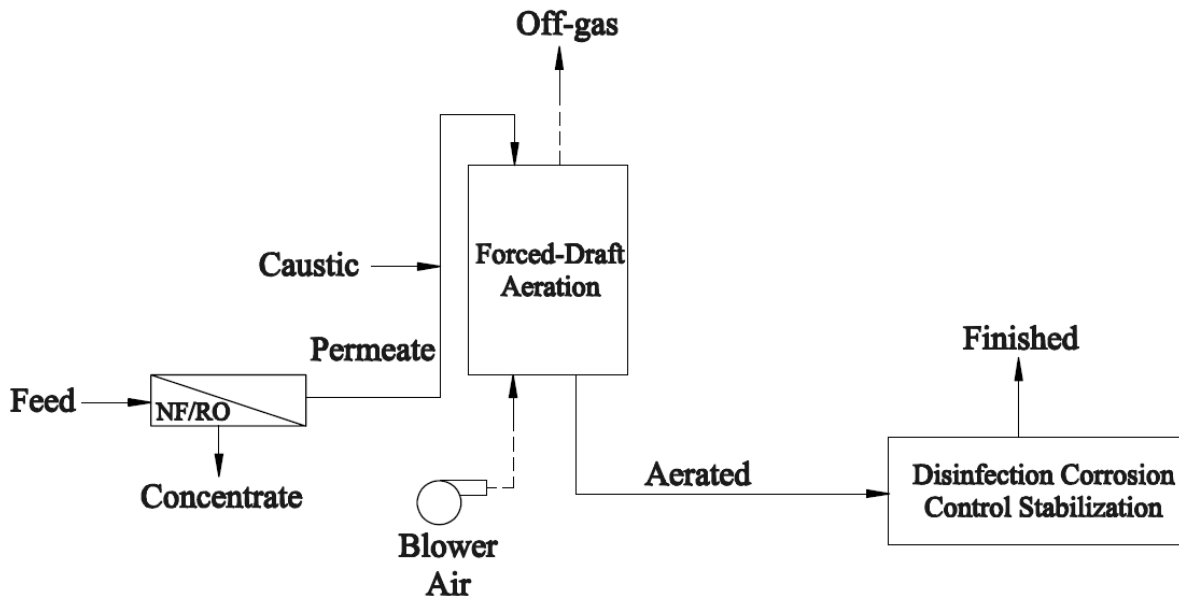

Figure 2-3: Alkalinity Recovery Process Flow Diagram

The following example calculation illustrates alkalinity recovery using the water quality achieved following disinfection. In the example, the pH before alkalinity recovery is past the point of alkalinity neutralization. Hence, additional base must be added to reach the point of alkalinity neutralization before alkalinity recovery can begin. The following scenario provides the calculation of finished permeate pH and alkalinity recovery following membrane softening.

Example for alkalinity recovery:

Assuming pH 3.9,  $0.0 \frac{mg}{L} HCO_3^-$ ,  $130 \frac{mg}{L} H_2CO_3 = 10^{-2.68} M$ , for permeate stream after chlorination.

$$\text{Base for Chlorination} \left| \frac{3 \frac{mg}{L}}{71 \frac{mg}{mmol} Cl_2} \right| \left| \frac{1 \text{ mol } H^+}{1 \text{ mol } Cl_2} \right| \left| \frac{1 \text{ mol } NaOH}{1 \text{ mol } H^+} \right| \left| \frac{40 \text{ mg}}{meq \text{ NaOH}} \right| \approx 2 \frac{mg \text{ NaOH}}{L}$$

Assuming pH 4.0,  $0.8 \frac{mg}{L} HCO_3^-$ ,  $129 \frac{mg}{L} H_2CO_3 = 10^{-2.68} M$ , for permeate stream after chlorination.

$$\text{Alkalinity Recovery} \left| \frac{62 \frac{\text{mg}}{\text{L}}}{62 \frac{\text{mg}}{\text{mmol}} \text{H}_2\text{CO}_3} \right| \left| \frac{1 \text{ meq H}_2\text{CO}_3}{1 \text{ mol NaOH}} \right| \left| \frac{40 \text{ mg}}{\text{meq NaOH}} \right| \approx 40 \frac{\text{mg NaOH}}{\text{L}}$$

$$\text{Finished Alkalinity} \left| \frac{61.8 \frac{\text{mg}}{\text{L}}}{61 \frac{\text{mg}}{\text{mmol}} \text{HCO}_3^-} \right| \left| \frac{1 \text{ meq HCO}_3^-}{1 \text{ mol HCO}_3^-} \right| \left| \frac{50 \text{ mg CaCO}_3}{\text{meq}} \right| \approx 50.6 \frac{\text{mg CaCO}_3}{\text{L}}$$

$$\text{pH} = \text{pK} - \log \left[ \frac{\text{HCO}_3^-}{\text{H}_2\text{CO}_3} \right] = 6.3 - \log \left[ \frac{10^{-3} \text{ M}}{(10^{-2.68} - 10^{-3}) \text{ M}} \right] = 6.28 \approx 6.3$$

### Aeration and Stabilization

If calcium and bicarbonate are present, the pH following aeration is controlled by  $\text{CaCO}_3$  buffering and can be estimated by Equation (2.18) assuming  $\text{CaCO}_3$  equilibrium.

$$\text{pH}_s = \text{pK}_2 + \text{pK}_{\text{sp}} + \text{pCa} + \text{pHCO}_3^- \quad (2.18)$$

The basic parameters that define the stabilization pH can be used to predict at what pH permeate should be conditioned to satisfy carbonate stabilization, as provided in the following example.

Example for aeration

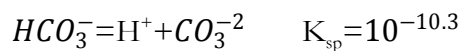
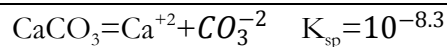

$$\text{pH} = \text{pK} - \text{pK}_{\text{sp}} + \text{p}[\text{Ca}^{+2}] + \text{p}[\text{Alk}]$$

$$[\text{Ca}^{+2}] = \left| \frac{4.1 \frac{\text{mg}}{\text{L}}}{40 \frac{\text{mg}}{\text{mmol}} \text{Ca}} \right| = 0.103 \text{ mM} = 10^{-3.99} \text{ M}$$

$$[\text{HCO}_3^-] = \left| \frac{61.8 \frac{\text{mg}}{\text{L}}}{61000 \frac{\text{mg}}{\text{mol}}} \right| = 10^{-2.99} \text{ M}$$

$$\text{pH}_s = \text{pK}_2 - \text{pK}_{\text{sp}} + \text{p}[\text{Ca}^{+2}] + \text{p}[\text{Alk}] = 10.3 - 8.3 + 3.99 + 2.99 = 9.0$$

### Calcium Carbonate Adjustment

The mechanism for this corrosion control strategy is the adjustment of the equilibrium for the calcium carbonate system for the source water. The objective for this treatment technique is the precipitation of a protective film of calcium carbonate onto the pipe walls. Calcium addition or removal is not necessary for the precipitation of calcium carbonate; rather this is accomplished with pH and alkalinity adjustment of the source water. The key to this treatment technique is to provide the conditions necessary for achieving calcium carbonate saturation.

Adjustment of the pH/alkalinity is done to create conditions necessary for the calcium and carbonate ions to exceed their solubility limits in water. Alkalinity or pH adjustment can be done with lime, soda ash, sodium bicarbonate or carbon dioxide. These chemical additives directly contribute calcium or carbonate ions to the water. The concerns with using calcium carbonate adjustment include:

- Precipitating a uniform protective film throughout the distribution system,
- Reduction in the hydraulic capacity of the water lines, and
- Scaling in mechanical systems, such as boilers and hot water heaters.

Scaling is of particular concern for those water systems with high levels of non-carbonate hardness and sulfate. Adjustment of the pH is necessary for the precipitation of calcium carbonate and iron stability. For lower alkalinity waters, sulfate can also precipitate calcium and cause scale.

### Use of Corrosion Inhibitors

Inhibitors have found wide spread use as a method of corrosion control. The most prominent forms of inhibitors used are polyphosphates, zinc phosphates, and silicates (AWWARF 1985). Operating data indicate that the choice of inhibitor depends upon pH, alkalinity, calcium and

total hardness, chloride, sulfide, iron concentrations, and dissolved oxygen levels of the source water. The inhibitors control corrosion by several mechanisms, including:

- Sequestering of the corrosion by-products, specifically lead and copper
- Scale inhibition
- Development of a coating film on the pipe walls
- Buffering the water at the desired pH

The mechanisms by which ortho-phosphates protect the surface are unclear. Unlike some corrosion scales that create a form of physical barrier to mass transport, phosphate films appear to passivate the corroding surface by changing the fundamental nature of the anodic reaction (Reiber 1989). The copper-phosphate protective films are ineffective in low pH waters. Exposure to pH values < 6.0 degrades the film, destroying its protective qualities within a matter of hours (Reiber 1989). Polyphosphates revert (hydrolyze) with time resulting in an increase in the ortho-phosphate ion (USEPA 1992). This slow reversion of the polyphosphate to the orthophosphate form can allow the film formation to travel further into the distribution system (Harms, et. al. 1994). The ortho-phosphate concentration must be maintained for the passivation to be effective as a corrosion control technique (Harms et. al. 1994).

However, addition of phosphates to the drinking water could ultimately aggravate operations and increase wastewater treatment costs. Zinc in wastewater can be a problem for receiving wastewater plants and may affect land application rates for biosolids derived from those plants (Ramaley 1993). For public water systems that apply a phosphate-based corrosion inhibitor, USEPA mandates measurement of ortho-phosphate. USEPA's rationale for this requirement is the lack of evidence supporting the ability of polyphosphates to control lead corrosion (USEPA 1991).

### *Stabilization of Desalted Permeate*

The need to stabilize water so that it would not enhance metal corrosion and concrete dissociation has been recognized for decades. In order to prevent corrosion in the distribution system, the water purveyor distributing the water for blending with other water sources will have to include post-treatment in order to stabilize the water. Permeate from RO and NF processes are specific to the plant and usually pilot studies should be done before blending waters in order to determine the parameters in permeate and the needed adjustment to stabilize the water, so that, for example, “red water” does not occur.

As noted by Fritzmann (2007), untreated permeate from sea or brackish water reverse osmosis plants does not conform to the drinking water standards such as WHO or the GDWQS. Due to the low TDS values RO permeate water can be unpalatable, corrosive, and un-healthy. Permeate must be re-hardened in order to prevent corrosion of pipes in the distribution network, pH value and carbon dioxide content need to be adjusted for scaling prevention and permeate water needs further disinfection.

Re-carbonation refers to process used to introduce bicarbonate and carbonate alkalinity to produce a positive LSI to prevent corrosion in pipes. Re-mineralization is a means of increasing the mineral content by addition to those, which increase the bicarbonate or carbonate alkalinity of the desalinated water as stated by Withers (2005).

The main groups of post-treatment processes currently exist for stabilizing reverse osmosis effluents:

1. Processes based on dosage of chemicals such as  $\text{Ca}(\text{OH})_2$  followed by  $\text{CO}_2$ ;
2. Processes that are based on mixing the desalinated water with other water sources, with or without further adjustment of water quality parameter; and



3. Processes that center around dissolving  $\text{CaCO}_3$  for alkalinity and  $\text{Ca}^{2+}$  supply followed by pH and CCPP adjustment using NaOH (Lahav and Birnhack 2007).

As stated by Lahav and Birnhack (2007), the first two groups are less commonly practiced because a) direct dosage of chemicals is usually expensive and b) desalinated water is diluted with other water sources further chemical dosage is usually unavoidable. The third process is the more cost effective of the two, particularly where  $\text{CaCO}_3$  is available per Lahav and Birnhack (2007).

The above processes are explained accordingly by Wither (2005) including others processed that will aid post-treatment. Re-carbonation processes are explained by Withers (2005) as a method to add alkalinity to water to make it non-aggressive and or non-corrosive. It is the breakdown of lime by carbon dioxide as shown in Equation (2.19) below:



According to Fritzmann (2007), the most widely used method for re-mineralization is the dissolution of limestone by carbon dioxide according to the following Equation (2.20).



This method will produce water with a pH equal to pHs. This method is mainly used because of the economic benefits in using limestone instead of lime and is cheaper overall.

Another method used is blending of desalination water with treated saline water source. As noted by Withers (2005), only partial stabilization can be achieved by blending the desalinated water with mineral rich waters such as brackish ground waters or seawaters. This can help to improve the organoleptic quality of the water. This option is generally undertaken only for distillates from thermal distillation facilities.

In a study done by Al Arrayedhy (1987) post-treatment of RO permeates is stabilized using the Equation (2.21)



These reactions were investigated by Al Arrayedhy (1987) that showed residual carbon dioxide may require further adjustment in the neutralization step of the RO process. Also alkalinity levels in the three processes shows neutralization with calcium carbonate and lime is better than neutralization with caustic soda.

Ruggieri and others (2008) developed limestone selection criteria for EDR water remineralization. Five commercially available limestones were characterized by mineralogical, chemical, and surface methods, including scanning electron microscopy (SEM). The main criteria in selecting a limestone for EDR water remineralization are its compositional purity in terms of both mineralogy and chemistry, and its textural characteristics. The dominant mineral phase in the uncontacted limestone was calcite ( $\text{CaCO}_3$ ), and included small amounts of dolomite ( $\text{CaMg}(\text{CO}_3)_2$ ) and quartz ( $\text{SiO}_2$ ) and trace levels of clay matter. In relation to mineralogical purity, it was recommended that the occurrence other than calcite should be avoided, and that the use of SEM was a useful tool in evaluating surface texture influence on suspended particulate matter generation upon consumption of the bed (calcite).

### *Inhibitors*

Inhibitors are especially formulated chemicals that are characterized by their ability to form metal complexes, which reduce the potential for corrosion. The treatment mechanism is passivation of the metal pipe surface. Inhibitors commonly form inorganic scales with the pipe material. The scale acts as a diffusion barrier to both reactants and products of the corrosion half reactions. The electrical potential increases at the interface between the scale and the pipe wall.

Inhibitors are generally used to prevent scaling and corrosion in the distribution system. By adding various inhibitors to the source, such as polyphosphates, accounted for control of corrosion. Phosphate inhibitors have been added to drinking water since the early 1900s. Phosphates were first used to prevent excessive calcite precipitation.

Researchers found that phosphates could sometimes prevent iron corrosion and red water problems (McNeill and Edwards 2001). Factors that determine the effectiveness of a particular inhibitor include:

- Initial water quality
- Type and dose of inhibitor
- Pipe material and condition

The corrosion rate of iron and copper depends on several factors, such as workmanship, flow velocity, etc., among others. Specific water quality factors include: pH, dissolved oxygen content, calcium saturation index, carbon dioxide levels and temperature. The relative ratio of chlorides, sulfates and bicarbonates also appear to influence the corrosion rate of pipe materials.

There are a diverse range of corrosion inhibitor formulations that are offered commercially by manufacturers/vendors. The two major types are phosphates and silicates. Inhibitors for use in potable water must comply with the standards established by the American National Standards Institute (ANSI) and NSF International, formerly the National Sanitation Foundation (NSF), Health Effect Standard 60 for Direct Additives to Drinking Water Supplies.

The common types of inhibitors available include:

- Blended phosphates
- Orthophosphates
- Polyphosphates Pyrophosphates
- Metaphosphates
- Zinc phosphates
- Silicates

The type of inhibitor that may be used for corrosion control is determined by the calcium, alkalinity, pH and temperature of the source water. Other constituents that may affect the selection of an inhibitor and the effective dose include iron, manganese, total hardness, sulfate, chloride, sodium and TDS. The use of inhibitors for corrosion control is analogous to the maintenance of chlorine residual within the distribution system. The elevated initial dose is reduced after the distribution system becomes stabilized. A typical maintenance dose is 0.5 to 1.25 mg/L. Consideration should be given to the secondary impacts of using an inhibitor, particularly if the product is a pollutant of concern or interferes with reuse of treated effluent from the wastewater treatment facility.

The optimal pH range and the maximum dose are shown for typical inhibitors in Table 2.2. Each type is discussed in the following sections. Inhibitors are effective over a constrained pH range. It is important to maintain the pH range throughout the distribution system as well as to utilize an inhibitor that is not subject to rapid hydrolysis effects. This requires that the source water be well buffered to the targeted pH range to prevent variations in the distribution system. Fluctuations in pH result primarily from low carbonate alkalinity.

## Phosphate Inhibitors

To improve effectiveness, the distribution system often requires pretreatment with an elevated concentration of inhibitor followed by a continuous feed at a lower pre-determined dose. Initially, the addition of phosphates may remove scale and tubercles from the pipes. Phosphate inhibitor is particularly effective when the phosphate becomes a part of the metal precipitate or scale formation on the pipe surface. However, the amount needed is typically system specific.

Operating parameters to be considered in the evaluation of phosphate inhibitors are: 1) maintenance of a stable pH throughout the distribution system; 2) inhibitor composition for the specific water quality objectives and conditions; and 3) determining the appropriate dosage. Phosphate inhibitors are acidic solutions and can affect the pH of the source water. Since the formation of the phosphate precipitate is pH dependent, this parameter has the most significant impact on the effectiveness of the inhibitor.

Phosphate inhibitors are available in a variety of compositions, including sodium orthophosphate, zinc orthophosphate, polyphosphates and ortho/polyphosphate blends. Each formulation has a different percentage of effective orthophosphate ( $\text{PO}_4$ ). Choice of a specific inhibitor requires consideration of the secondary impacts on wastewater treatment facilities, including the quality of the sludge and the effluent or reclaimed water for reuse. Orthophosphates appear to be the most effective inhibitor for a wide range of pipe materials. Copper solubility may not be reduced significantly by orthophosphates in solution. High doses generally are required for sequestering or passivation of copper in the source water. However, orthophosphates reduce the corrosion rates of iron, lead and galvanized steel. Orthophosphate precipitates metals at pH values above 7.8, which can cause a scale build-up within the distribution system pipes. Ortho-

polyphosphates were developed to provide the benefits of both polyphosphates in the treatment facilities and orthophosphates for corrosion control in the distribution system.

Polyphosphates, upon addition to water, hydrolyze with time to form orthophosphate ions. The rate of hydrolysis depends on pH and metal ions (such as calcium and zinc) present in potable water (Schock 1990). Monitoring of lead levels should be conducted to verify that the addition of polyphosphate inhibitors does not increase the solubility of this metal. Polyphosphates are typically used to sequester dissolved metals or cationic constituents, such as calcium, iron or manganese. This reduces their ability to precipitate in the distribution system.

According to McNeill and Edwards (2001), Polyphosphates were the first phosphates compounds used in corrosion control. Numerous studies have found that polyphosphates could prevent corrosion and/or control red water. The theory of polyphosphate corrosion prevention varies widely. Some researchers claim that polyphosphates adsorbed onto the iron surface to form a protective layer, where other studies have stressed the importance of calcium in polyphosphates effectiveness. In theory, polyphosphates may significantly increase the solubility of lead in domestic plumbing systems yet formulations containing more orthophosphate would be advantageous for use in potable water applications (Holm and Schock 1991). The effectiveness of polyphosphate decreases dramatically as the pH of the water increases above 7.0. This is due to the transition from a thick electro-deposited protective scale to a lighter adsorbed scale. Polyphosphates have been used to minimize the encrustation of filter media by post-precipitation of calcium carbonate. Polyphosphates can also effectively reduce the aesthetic coloration from Fe and Mn.

Table 2-3: Operating Considerations of Typical Corrosion Inhibitors

Type	pH Range	Maximum Dose-mg/L
<b>PHOSPHATES</b>		
<b>ORTHOPHOSPHATES</b>	6.0 to 7.8	
Dipotassium		18-36
Disodium		14.3
Monopotassium		14.9
Monosodium		12.6
Tripotassium		22.4
Trisodium		17-41.5
Tricalcium		120
Zinc		20-50
Phosphoric Acid		12-14
<b>POLYPHOSPHATES</b>	7.6-8.0	
Polyphosphoric Acid		8.9
Potassium Tripolyphosphate		15.7
Sodium Glassy		10
Polyphosphate		10-12.9
Sodium Tripolyphosphate	7.5-8.3	
<b>PYROPHOSPHATES</b>		11.7
Sodium Acid		16.6-29
Tetrapotassium		10-14
Tetrasodium	7.0-9.0	
<b>METAPHOSPHATES</b>		12
Sodium Hexa-metaphosphate		10.7
Sodium Tri-metaphosphate	7.0-8.0	
<b>SILICATES</b>		25
Sodium		25
Potassium		

Source: NSF Drinking Water Additives – Health Effects Standard 60 (June 1995)

Blended phosphates consist of a mixture of both orthophosphate and polyphosphates. The mixture combines the corrosion inhibiting properties of the orthophosphate ion with the sequestering ability of the polyphosphates. Orthophosphate is an anodic inhibitor that suppresses the release and flow of electrons. Polyphosphates form a protective film on the pipe walls and inhibit the cathodic reaction. Metal phosphate complexes must achieve sufficient thickness to significantly reduce the rate of corrosion. Blended phosphates do not prevent metal corrosion, but they reduce the rate of corrosion to a manageable level.

Zinc orthophosphates are particularly effective for inhibition of iron and galvanized steel corrosion, especially at higher pHs. The typical dose is 1 to 2 mg/L. Pretreatment is required for initial scale formation. The presence of zinc reduces the dosage of phosphate for corrosion protection and increases the rate of inorganic scale formation on the pipe interior surface. Although little documentation exists in the literature to suggest that zinc phosphate inhibitors are effective for corrosion control, a recent study performed on 48 large and medium operating WTPs did show that zinc orthophosphate addition reduced 90th percentile lead concentrations at the consumer's tap (Becker et.al. 1993). However, limitations in wastewater treatment or solubility limitations of basic zinc carbonate might provide limits on the use of zinc phosphate inhibitor formulations (Schock 1990). The concerns with using phosphate inhibitors include:

- Acceleration of bacterial re-growth potential in the distribution system
- Decreased effectiveness with stagnant water conditions in dead-ends of service lines
- Secondary impacts on wastewater treatment facilities, particularly effluent discharge standards and zinc concentrations in the bio-solids.

In the 1960's, manufactures began blending polyphosphates and orthophosphates with 5-25% zinc to form bimetallic phosphates, claiming either that the presence of zinc accelerated polyphosphate film formation or the zinc orthophosphate or zinc polyphosphate film was superior to regular phosphate films for inhibiting corrosion. These compounds reported a decrease in the corrosion compared to regular polyphosphates. However several studies found no benefit of zinc phosphates compared with regular phosphates (McNeill and Edwards 2001).



## Silicate Inhibitors

Silicate inhibitors are prepared from the fusion of high quality silica sands to sodium or potassium salts. Sodium silicates are the most common form for this type of inhibitor. Sodium carbonate serves as the bonding salt, which, due to the alkalinity added, raises the pH of the water. The typical ratio of silicate to sodium carbonate is a molar ratio of between 1.5 and 4 to 1. The typical inhibitor solution has 37 to 38 percent solids and a 3.22 weight ratio. Other formulations are available.

The effectiveness and the mechanism by which silicates inhibit corrosion of the internal surfaces of pipes are perhaps the least understood of inhibitor processes, even though silicates have been used regularly for corrosion control since the 1920s (Thompson 2003). The mechanism for corrosion control using silicate inhibitors appears to be a combination of absorption and the formation of insoluble metal silicate compounds. Silicate inhibitors are considered to be anodic.

Drinking water utilities have used silicates for decades. Initially, silicates were used for red water complaints in the distribution system. Also, silicates were used for zinc and aluminum corrosion control. More recently, silicates have been found to reduce red and black water complaints resulting from the oxidation of naturally occurring iron and manganese in groundwater.

Research indicates a slightly corroded surface may be necessary to form the protective silicate film. X-ray examination of pipe walls indicates the presence of a two layer protective film on cast or ductile iron pipes. The film is composed of an amorphous silicate layer that is adhered to an underlying silicate/metal surface.

Silicate inhibitors are more effective than their phosphate counterparts in suppressing crevice or pitting corrosion. This is due to the alkalinity provided by the bonding salt. A dissolved oxygen concentration above 0.25 mg/L is necessary for silicate inhibitors to form a film on oxidized

metal surfaces. Silicate inhibitors significantly reduce the corrosion of A/C pipe. The silicates combine with the pipe material to form a quartz-like protective film.

Historically, silicate inhibitors have received mixed opinions due in part to the mystery surrounding its functionality and the wide variety of different experimental results. Silicate compounds were originally used as a coagulation aid. Early studies found that natural silica present in water was concentrated in the relatively protective iron scale. Addition of silicate based inhibitors has also been found to reduce iron corrosion rate and raise the pH, which is generally beneficial toward iron corrosion.

In a study by LaRosa-Thompson and others (1997), X-ray photoelectron spectroscopy (XPS) analysis showed that a silicate film forms on the interior of the pipes. This film helps inhibit corrosion as indicated by the studies in which silicates were compared to sodium hydroxide of the same pH. Silicate provided more corrosion control than NaOH. Some experiments had a negative influence on the effectiveness of silicate because of their design. The following consequences of silicates use include:

- Difficulty in controlling the rate of deposition of silicate-based film on the pipe walls
- Release of corrosion by-products into the potable water
- Protective films cannot be re-dissolved
- Continuous treatment is necessary
- Effectiveness is reduced by low flow velocities and higher pH levels
- Metal ions can exert a high demand for the inhibitor
- Glassification of mechanical equipment
- Minimal operating data to confirm the corrosion control ability of copper for source water with high calcium concentrations

Successful attempts of mitigating lead release with silicate have been documented as early as the 1920's (Thresh, 1922). Despite its history of application, there have been few studies documenting quantitative relationships between silicate and metal (lead) release. Of the few studies, there remains a general uncertainty surrounding the nature by which Si effects lead release. Early studies were carried out by Lehrman and Shuldener (1951) that assessed the possible mechanism of silica film formations in distribution systems.

Relatively recent studies have had mixed implications on the effectiveness and role of silicate for corrosion control. Generally, silicate addition has been documented within the literature as beneficial (Schock and Wagner 1985; Johnson 1993; Lytle 1996; Pinto 1997; Chiodini 1998; Schock 2005). However, the association between silicate dose and pH has proven to present difficulties when comparing with a control. In some cases, the pH of the control will remain unadjusted, implying that the difference between the control and Si treated experimental unit will consist of an effect from pH and silica. The beneficial effect of pH increase for lead control was been well documented (Schock 1988). Because of the increase in pH associated with Si addition, some researchers have suggested that the effect of Si is essentially equivalent to pH adjustment (Ryder 1985).

### Blending Considerations

The process of generating fresh water from brackish or salt water using a reverse osmosis system yields a product water (permeate) that is, both low in pH and alkalinity. If the pH and alkalinity of this water is not adjusted, it will create a corrosion problem in the existing water distribution system. These problems include but are not limited to issues with the taste and odor of the water, discoloration of the water (turbidity), and corrosion of distribution components.

Adding or blending pre-treated source water into the product water (permeate) can help in stabilizing the product water thereby reducing the impact of the before mentioned issues but introduces the need for disinfection of the pre-treated water prior to or after blending. Selection of post-treatment processes may not completely consider the impacts on the distribution system, particularly when blending multiple varying supplies (Lovins 2004b; Duranceau 2005). This subject is of great importance for many water purveyors. Blending of variable and differing water supplies where desalted water serves as one of the supplies is increasingly become more frequent.

#### *Blended Water Ratios*

Blending Ratios can be calculated by a mass balance Equation (Bergman and Elarde 2005). When blending waters from multiple sources, it is helpful to use a multi-objective technique to evaluate the optimum blend for a particular distribution system requirement. Water blended to produce an alkalinity level increases the corrosion of copper and lead components but reduces the corrosion of iron components. Blending to produce a high level of sulfates in the product water will lead to an increase in the corrosion of iron components but decrease corrosion of copper components. These conflicting attributes indicate that the utility maintaining the distribution system need to identify the necessary mixture for their particular system (Imran et al. 2006).

Furthermore, blending of permeate with native waters for post-treatment purposes could be limited by the amount of iron and manganese concentrations present in the native water, as these constituents can cause taste and odor, stains, and hence would limit overall blend ratios. In addition, if the native water used as a source of blend water consists of natural organic matter, which could impact disinfection by-product formation in the blended water. This is significant if bromide of appreciable amounts (on the order of 0.5 mg/L) is present in the post-treated permeate, where disinfection is required. Blended water may also contain unwanted pathogens (Bergman and Elarde

2005). When integrating into an existing system, control over disinfectants and fluorination chemicals should be optimized for maximum efficiency (Duranceau, 2006).

### Impacts On Existing Distribution System Infrastructure

As water is transported through a distribution system, physical, chemical and/or microbiological transformations may occur, resulting in degraded water quality. Aged water distribution systems typically have achieved some state of quasi-equilibrium and have as a result minimal problems. However, changes in water quality and conditions can affect water distribution systems significantly, particularly if new water supplies or different water supplies are used to supplement water resources for the community. This is often the case when existing ground water supplies are converted to a mixture of surface water and desalted source waters. These interactions occur in the bulk water phase and surfaces in contact with the water column.

### *Blending Water Compatibility*

Water to be used for blending must be analyzed to determine that they are chemically compatible and that the total dissolved solids, color, and DBP formation potential will not adversely affect the water quality (Bergman & Elarde, 2005). When blending water from multiple sources a blending facility will be required to reduce variations in water quality (Duranceau, 2006). The important of predicting the possible chemical mixture of the product water is of great importance, therefore a number of mixing methods need to be employed (Trussell and Thomas 1971)

Tampa Bay Water and the American Water Works Association Research Foundation commissioned a study on corrosion problems in water distribution systems that have historically relied on ground waters that are now being required to get water from other sources. A pilot plant was constructed using pipes from the existing distribution system. These pipes consisted of

polyvinyl chloride (PVC), unlined iron, lined iron, and galvanized iron pipes. The pilot plant blended water from three sources; groundwater (GW), surface water (SW), and desalted water (RO). This plant was operated for 2 years and detailed sampling was taken of the various water blends and piping combinations.

Collected data was then used to create a mathematical model that would be used to calculate the corrosiveness of different water blends. The input variables for the corrosiveness model are pH Alkalinity, Calcium, Magnesium, Sodium, Chlorides, Sulfates, UV<sub>254</sub>, Iron, Turbidity, Dissolved Oxygen, Apparent color, Chlorine, and Conductivity. The mathematical Equation (2.22) is as follows:

$$\Delta C = \left[ \frac{10^{\beta 0} * (DO)^{\beta 1} * (Cond)^{\beta 2} * (SO_4^{2-})^{\beta 3} * (Cl)^{\beta 4} * (Na)^{\beta 5} * (T)^{\beta 6} * (HRT)^{\beta 7}}{[(ALK)^{\beta 8} * (Ca^{2+})^{\beta 9} * (SiO_2)^{\beta 10} * (UV)^{\beta 11} * (pH)^{\beta 12}] } \right] \quad (2.22)$$

Iron was released from both unlined cast iron pipe and galvanized steel when the finished water alkalinity was less than the ground water alkalinity in the blend. The iron was predominantly to be found in the particulate form, which could result in high color. Minor color release was also observed in blends that contained increased levels of sulfates (from treated surface water) or chlorides (from desalted permeate). There was found to be no significant color release from PVC or lined cast iron pipe. The input variables for the iron release model are temperature, alkalinity, Cl, Na, SO<sub>4</sub>, DO, and HRT. The mathematical formula is shown in Equation (2.23).

$$\Delta C = \frac{(Cl)^{0.485} * (Na)^{0.561} * (SO_4^{2-})^{-0.118} * (DO)^{0.967} * (T)^{0.813} * (HRT)^{0.836}}{(10)^{1.321} * (ALK)^{0.912}} \quad (2.23)$$

Models were further created to predict the release of copper, the release of lead, the release of iron, and the dissipation of monochloramine's in the distribution system. The input variables for the copper release model are temperature, alkalinity, pH, SO<sub>4</sub>, and SiO<sub>2</sub>. The mathematical formula is shown in Equation (2.24).

$$Cu = (T)^{0.72} * (ALK)^{0.73} * (pH)^{-2.726} * (SO_4^{2-})^{0.1} * (SiO_2)^{-0.22} \quad (2.24)$$

The release of total copper was also described by steady-state water quality models and was found to exceed the copper action level when groundwater alone was utilized due to high carbonate alkalinity. The adverse effects of alkalinity on copper release had been historically been mitigated through the use of pH adjustment and corrosion control inhibitor addition. A positive aspect of blending surface water with mixtures of ground and desalted seawater was reduced copper corrosion. Lead historically had not been a challenge for the water system studied, but was a concern when the system was converted to a blended water of desalted seawater, iron-coagulated and filtered surface water, and groundwater. Similarly, the input variables for the lead release model are temperature, alkalinity, pH, SO<sub>4</sub>, and Cl. The mathematical formula is shown in Equation (2.25):

$$Pb = (1.027)^{(T-25)} * (ALK)^{0.677} * (pH)^{-2.86} * (SO_4^{2-})^{-0.228} * (Cl)^{1.462} \quad (2.25)$$

Based on these findings, TBW has maintained finished water alkalinity of 100 mg/L as CaCO<sub>3</sub>, or more, which offsets the majority of released color from unlined iron piping components. Also, blends that contained more than 60 percent ground water created unacceptably high releases of copper into the distribution system, while blends with less than 20 percent increase corrosion due to the low alkalinity of the water. Blends with desalted water allowed this ratio to increase.

It was also determined that blends with high ratios of desalted and surface waters should be avoided as they result in corrosive blends. Limitations on the amount of ground water available for blending may require the use of inhibitors in the blend. These results were for low flow conditions. High flow distribution systems would be required to calibrate the models in order to compensate for velocity gradient conditions. Dissipation of chlorine residuals was found to be dependent on pipe material, geometry, hydraulics (residence time and velocity), and water quality (organic carbon). Combined chlorine dissipated more rapidly than did free chlorine in reactions with the pipe wall for

unlined cast iron and galvanized steel pipes, and less rapidly in reactions with the bulk water. These results indicated that maintenance of any residual in a summertime conditions (30 °C) will not be possible for hydraulic conditions that exceed 48hrs in galvanized steel and difficult in unlined cast iron pipe. Also, it was shown that free chlorine was found to maintain 100 times (2 log) less HPC growth than chloramines.

The transition effects for total iron, copper, and lead (that is, changing of water quality from one blend or source to another) were predictable using steady-state models developed for iron, copper and lead release and coupled with time-release models. Total iron, copper and lead transition following blending would produce predictable effects that would stabilize in 30 to 40 days. The results indicated that potential adverse of blending could be mitigated if anticipated.

Blending can improve the stability of the product water by increasing the alkalinity and calcium in the permeate and reduce the corrosiveness of the water (Hendricks 2006; Binnie, Kimber, and Smethurst 2002). The water that is to be used for blending may be the source water used for the reverse osmosis process or from another source (Bergman & Elarde, 2005). When integrating into an existing system, control over corrosion inhibitors and pH adjustment should be optimized for maximum efficiency (Duranceau, 2006). It is necessary to model the affects of different blends to prevent the release of red water in the distribution system (Imran, et al., 2005).

Unfortunately, blending will not stabilize the product water completely. The permeate will still need to have calcium infused into it. This can be accomplished by employing either lime or limestone treatment. If the source of the water to be blended with the product water from the reverse osmosis system is from a ground source from a limestone or chalk geological formation, the amount of lime treatment will be substantially reduced (Withers, 2005).



Blending will reduce the stress on the membrane system as it reduces the amount of water that needs to be treated and thereby reduce the operating costs of the system (Bergman & Elarde, 2005). The utility will need to develop a unidirectional flushing program for the reverse osmosis system. The utility will need to increase storage reservoir size and maintenance. The utility should expect to see an increase in its operational and maintenance expenses (Duranceau, 2006).

### Red Water Experiences

Red water is a phenomenon that describes a situation where a layer of iron oxides is detached from the internal surface of metal pipes into water (Lahav and Birnhack, 2007). Post-treatment to meet drinking and irrigation water standards is therefore an essential part of most reverse osmosis plants according to Fritzmann et al., (2007).

The most problematic phenomenon in urban distribution systems is related to the release of dissolved metals to the water (Lahav & Birnhack 2007). Desalinated water has been pumped directly into the distribution system without being mixed with other water sources in the system. The permeate water is then blended with the water sources in the pipe and will cause problems in the system. The most problematic occurrence is the phenomenon of “red water” which describes a situation where a layer of mostly iron oxides is detached from the internal surface of metal pipes into the water and arrives at the consumer’s tap with a characteristic yellow-brown-red color (Lahav & Birnhack, 2007).

Corrosion of iron pipes according to McNeill and Edwards (2001) in a distribution system can cause three distinct related problems. 1) Pipe mass is lost through oxidation to soluble iron species or iron bearing scale. 2) The scale can accumulate to large tubercles that increase head loss and decrease water capacity. 3) The release of soluble or particulate iron corrosion by products to the water decreases the aesthetic quality and lead to consumer complaints of “red water” at the tap.

Selection of post-treatment processes may not completely consider the impacts on the distribution system, particularly when blending multiple varying supplies (Lovins et al., 2004b; Duranceau, 2005). Only recently has this subject become of importance for many water purveyors. Blending of variable and differing water supplies where desalted water serves as one of the supplies is becoming increasingly more frequent.

A considerable number of studies exist that describe the potential problems that may occur when waters that have different chemical characteristics are supplied intermittently into distribution systems as stated by Imran et al., (2005). The most problematic occurrence is the phenomenon of "red water" which describes a situation where a layer of (mostly) iron oxides is detached from the internal surface of metal pipes into the water and arrives at the consumer's tap with a characteristic yellow-brown-red color. In this regard Tang et. al., (2006) state appropriately that adverse impacts of blending different source waters on iron release have not yet been investigated systematically. Nevertheless, large occurrences of the red water phenomenon, such as the one reported in 1993 by Price in the city of Tuscan, Arizona, due to an abrupt change in the water source affected the confidence that the public had in the local water authorities, especially if the public becomes aware of a possible connection between the problem and the introduction of a new water source (e.g., desalinated water). Another well known problem is the deterioration of metal pipes due to slow corrosion. Beyond destroying the pipes, the products of corrosion consume chlorine products rendering disinfection less efficient, it creates scales on the pipe's surface that increase the energy required for pumping, it supports biofilm growth and may produce suspensions of (mainly) iron particles that result in water that are not appealing to the consumer per Sarin and others (2004) .

To date, no formal unifying regulations exists worldwide that define unequivocally the quality of desalinated water that should be released to a distribution system. In most places the

desalinated water is simply expected to conform to the general water quality requirements. Specific issues such as quality problems that may arise from the in-line blending of desalinated water with ground water or the lack of certain minerals in the water when it is used for drinking and/or agricultural irrigation are to-date being thoroughly addressed for the first time per the WHO and Yermiyahu (2006, 2007). The need to stabilize the water so that it would not enhance metal corrosion and concrete dissolution has been recognized for decades.

The most problematic phenomenon in urban distribution systems is associated with the release of dissolved metal ions to the water (mostly iron ions but also  $Zn^{2+}$  from galvanized pipes and  $Pb^{2+}$  and  $Cu^{2+}$  ions from certain fittings, invariably installed in water distribution systems). In Israel the problem is typically restricted to small diameter (<3") pipes in the urban and household systems (pipes with greater diameters are typically protected by cement coating). Since the most stable thermodynamic state of iron is Fe(III), elemental iron solid tends to donate electrons and transform into Fe(II) and Fe(III), with dissolved oxygen and chlorine species being the most common electron acceptors in the distribution system. This unavoidable phenomenon causes the formation of a layer on the internal surface area of the pipe, which is typically referred to as a "corrosion scale".

Depending on specific conditions, the reactions may result in a continuous dissolution of metal ions into the water, or may give rise to precipitation of minerals on the active electro-chemical sites on the pipe's internal surface. The latter occurrence may cause the formation of a "passivation layer", which, depending on its properties (width, density, species composition), can serve, on the one hand, as a protection layer which reduces the diffusion of dissolved oxygen and ions to the surface of the pipe and thus reduces the rate of corrosion and disintegration of the pipe, but on the other hand, its sudden collapse/dissolution may cause the release of a relatively large amount of iron

(and other) species into the water which may cause the known phenomenon of "red water" to occur as stated by Suibing (2007).

With regard to establishing an effective passivation layer, the chemical stability of drinking water is commonly described by three parameters: (1) the buffering capacity of the water, i.e. the ability of the water to withstand substantial changes in pH when a strong base or a strong acid are added to it, which is a function of the alkalinity and pH values; (2) the propensity of the water to precipitate  $\text{CaCO}_3$ , which can be controlled by a variety of qualitative (e.g., Langelier) and quantitative (e.g., the Calcium Carbonate Precipitation Potential, CCPP) indices; and (3) the soluble  $\text{Ca}^{2+}$  concentration in the water. The fourth relevant parameter, pH, is a dependant parameter that is determined by the values of the previous three. However, pH is the easiest to measure and control, and thus, combined with alkalinity and  $[\text{Ca}^{2+}]$  are the parameters used to assess and control water stability, typically via the CCPP.

Corrosion inhibitors are also used to decline the corrosives of CF/RO treated water. Per the AWWA (2007), phosphate and silicate inhibitors can form protective films on pipe walls that limit corrosion or reduce metal solubility. Orthophosphates react with pipe metal ions, which build a passivation layer. And silicate inhibitors can form a glasslike file on pipe walls. These inhibitors should be added a few weeks to allow these protective films to form.

### Permeate and Agriculture

#### *Desalted Seawater Supplies and Permeate Boron Concentrations*

Boron is naturally occurring in the environment, the majority of which occurs in the ocean, a result of the natural weathering of landmass sedimentary rocks (Magara et. al. 1998), its presence in silts, or introduction because of detergents or soap usage (Bick and Oron 2005). Seawater contains

between 4 and 6 mg/L of boron, and up to 7 mg/L in the Arabian Gulf, the amount of which depends on global location and season. Boron typically exists as non-ionic boric acid [B(OH)<sub>3</sub>] in natural seawater having a pH range between 7.7 and 8.3 pH units, since boron has a pK<sub>a</sub> of 9.3 at 20 degrees Celcius as shown in Equation (2.26) (Rodriguez et al. 2001):

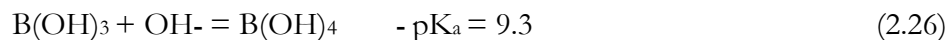

In 1993 the WHO issued a drinking water boron guideline value of 0.3 mg/L (WHO 2004), whereas, the Japanese Water Quality Standard for boron remained 1.0 mg/L (Melnik et al.,1999). This value was amended to 0.5 mg/L in 1998, and may be further revised to an increased value between 1 and 2 mg/L in the near term, based on criteria established for human health concerns because boron is suspected to cause birth defects at high concentrations. The lower standard levels have been historically associated with agricultural concerns, as boron at elevated levels may be harmful to crops when desalinated seawater is used for irrigation purposes. Although trace quantities of boron are essential for plant growth, higher levels of crop boron exposure can cause foliage damage, premature ripening of fruits and in some cases toxic to citrus and other tree species at elevated levels (Bush et al. 2003). For example, although most citrus species have a boron tolerance of only 0.4 to 0.75 mg/L, vegetables can withstand boron exposures as high as 4 mg/L (Bick and Oron 2005).

Since seawater RO membranes remove only 40 to 60 percent of non-ionic boron from the feedwater, depending on membrane type, age, pretreatment pH and temperature (Perov et al., 2003), permeate water boron values can range between 1.0 and 2.0 mg/L (Prats et.al. 2003), which is higher than current WHO guidelines. Rejection of boron is significantly improved when the pH is higher, due to the boron existing as the ionized borate species [B(OH)<sub>4</sub>]<sup>-</sup>. Boron rejection will thus increase with degree of dissociation, rising for example from 80 percent to 99 percent at pH 9 and 11,

respectively. Therefore, seawater desalination plants will typically employ additional methods of treatment to achieve this goal, which can include:

- The passage of permeate water through additional RO treatment trains (treatment pass);
- Adjustment of the permeated pH prior to further brackish water RO processing;
- Increasing the pH of the feed water for increased seawater boron rejection;
- Treatment of permeate with ion-exchange; or,
- Blending permeate with an alternative non-saline water sources.

Taniguchi (2004) investigated two post-treatment processes relative to boron removal from water supplies: brackish water RO and adsorption. It was determined that whereas RO is not effective a lower operation pH, adsorption has been shown to be very effective. However, the adsorption process requires a large empty bed contact time and requires expensive medias. As a result, combined or hybrid process trains have been proposed as alternative treatment options.

Bonnelye and others (2007) showed that boron exists primarily as boric acid a pH of approximately 8.2 in Curacao seawater, and investigated the use of a two-pass RO system for the control of boron in the permeate water. The second pass included the use of caustic soda addition for pH adjustment to transform boric acid to borate, which was shown to increase Boron rejection. Post-treatment included re-mineralization through limestone filters, UV disinfection and GAC filtration, and the process achieved a finished water boron level of 0.3 mg/L.

As a result, the additional requirements needed for increased boron removal will increase the cost of seawater desalination. The lower value for boron is an agriculture-related issue reflecting boron's herbicidal effect at values of 0.5 mg/L or higher for some crops. The difference in a treatment goal of 1 mg/L and 0.3 mg/L for boron could mean the difference between a single-pass

RO process and a two-pass RO process, translating to a 15 or 20 percent increase in total present cost for the additional capital, operation and maintenance costs associated with additional treatment.

#### *Desalination and the Sodium Adsorption Ratio*

As the use of desalinated water supplies continues to grow, its use for irrigation will also continue to increase. For example, in Spain, approximately 22 percent of desalinated water is used for agricultural irrigation (Beltran and Koo-Oshima 2006). In light of several new Australian plants coming on-line, an Australian survey determined that 53 percent of the population is anticipating that desalinated water will be used for irrigation in the future (Dolnicar and Schafer 2006). In Israel, water desalinated from the Mediterranean Sea at the Ashkelon facility provides water for both municipal and irrigation purposes (Lahav and Birnhack 2007).

However, desalination removes ions that are essential to plant growth, and if used to replace irrigation water that previously provided basic nutrients like calcium, magnesium and sulfate at levels sufficient to limit the need for additional fertilization requirements. Calcium is important for proper plant growth, and changes in its content and relative concentrations can be problematic for agriculture (Yermiyahu et al 2007). Moreover, sulfate is removed from the permeate during desalination. Sulfur deficiency could become a problem in other systems where alternative methods for calcium enrichment are practices. For horticultural purposes, the average recommended sulfate concentration in irrigation water ranges from 141 mg/L (as S) for tomatoes to 58 mg/L (as S) for non-vegetable crops. Other constituents that may create potential impacts on vegetation include salinity, suspended solids, biodegradable organics, pathogens, nutrients, stable organics, pH, heavy metals, dissolved organics, and residual chlorine.

The sodium adsorption ratio (SAR) is defined as being the concentration of sodium (Na) divided by the square root of the quantity equal to one half of the sum of the concentrations of

calcium (Ca) and magnesium (Mg), where all concentrations are expressed in milliequivalents per liter, as shown in equation (2.27):

$$SAR = \frac{Na}{\sqrt{\frac{Ca+Mg}{2}}} \quad (2.27)$$

The SAR commonly is used in association with electrical conductivity (EC<sub>w</sub>) of the irrigation water to evaluate potential hazards associated with sodium (Rowe and Abdel-Magid 2007). Table 2-3 illustrates the degree of concern related to SAR and EC<sub>w</sub>: Desalinated water typically will have very low EC<sub>w</sub> values.

Table 2-4: SAR Versus EC<sub>w</sub>

SAR	Conductivity (µmhos/cm) and Degree of Restrictions on Use		
	None	Moderate	Severe
0-3	EC <sub>w</sub> >700	200<EC <sub>w</sub> <700	EC <sub>w</sub> < 200
3-6	EC <sub>w</sub> >1,200	300<EC <sub>w</sub> <1,200	EC <sub>w</sub> <300
6-12	EC <sub>w</sub> >1,900	500<EC <sub>w</sub> <1,900	EC <sub>w</sub> <500
12-20	EC <sub>w</sub> >2,900	1,300<EC <sub>w</sub> <2,900	EC <sub>w</sub> <1,300
20-40	EC <sub>w</sub> >5,000	2,900<EC <sub>w</sub> <5,000	EC <sub>w</sub> <2,900

Source Rowe and Abdel-Magid, 2007

The effect of the SAR is that sodium will take the place of the calcium and magnesium present in the clay particles of the soil. This reaction reduces the effective infiltration capacity of the soil. The SAR is of great concern in areas with high clay content, however in areas with sandy soil containing little to no clay, the SAR concerns are less critical. The SAR is also of less concern when regular “leaching” occurs when water with little to no sodium content washes the soil profile. An example of this would be seasonal rains on an annual basis. The third concern with the SAR is the salinity, which is measured as conductivity. As the conductivity increases, the SAR’s infiltration effects are not as critical, so that a range of 3 to 7 is provided for blending targets for desalinated permeate.



Conductivity, sodium adsorption ratio, calcium, magnesium, potassium and sodium are the more critical parameters monitored for the proper management of turf grass for golf course facilities. Typical irrigation water quality goals for Bermuda turf grass is provided in Table 2.4.

If the minerals required for agriculture are not added to the permeate water prior to irrigation, affected agricultural industries will need to supplement required nutrient loadings via the use of fertilization or blending with native sources, either of which may be cost prohibitive (fertilizers) or limited due to drought or climate change (native sources).

Table 2-5: Irrigation Goals for Bermuda Grass

<b>Parameter</b>	<b>Units</b>	<b>Range of Water Quality Acceptable for Bermuda Grass</b>
Conductivity	µmhos/cm	2,000 to 5,000
Soil Adsorption Rate (SAR)	---	3 to 7
Calcium	mg/L	40 to 120
Magnesium	mg/L	6 to 20
Potassium	mg/L	0.5 to 10
Sodium	mg/L	0 to 50
Iron	mg/L	2 to 5
Alkalinity	mg/L	30 to 100
Chloride	mg/L	177 to 355
Sulfate	mg/L	0 to 414
TDS	mg/L	1000 to 5000
Boron	mg/L	0.2 to 0.8

*Source: Rowe and Abdel-Magid, 2007*

### Summary of Literature Review Findings

Desalination will result in the production of water having low dissolved solids content that can and will cause internal corrosion, and may not be fit for human consumption. Pure water is considered a reactive chemical: when air is dissolved in extremely pure water, the resultant solution is very corrosive. Water that contains little to no hardness would be considered unhealthy for potable use and water that contains no dissolved oxygen may be offensive and taste flat. Consequently, post-treatment of membrane desalinated water is required prior to storage and distribution for municipal water purveyors, and must include disinfection.

There are four primary issues concerning the post-treatment water. These relate to blending, remineralization, disinfection and the materials used for storage and transport of the water to the tap. Desalinated water is often blended with other sources that contribute minerals to the final blended water. Seawater as a source for blending is limited due to issues related to corrosivity and taste if the blending levels exceed about 1%. Blending of permeate water with seawater results in the addition of sodium, potassium, calcium, and magnesium to drinking-water but also will contribute bromide and iodide which are DBP precursors, and is limited in quantity due to the significant concentrations of these constituents. Consideration should be given to the natural minerals present and whether these will result in finished water having unacceptable water qualities in addition to unacceptable taste and odor.

Membranes do not remove small, uncharged molecular contaminants or dissolved gases such as carbon dioxide, hydrogen sulfide and methane. If hydrogen sulfide is present in a source ground water, it must be removed, typically by packed tower or air stripping processes prior to disinfection and distribution to consumers. If sulfides are removed in the stripping process, then provision are also made to remove (scrub) the off-gas sulfides from the air stripping tower off gas to prevent odor

and external corrosion issues on surrounding buildings and infrastructure. The stripping of carbon dioxide and hydrogen sulfide raises the pH and reduces the amount of base needed to perform stabilization. Permeate is typically low in calcium, magnesium, alkalinity and may have a low pH if acid was used for pretreatment ahead of the membrane process. Since the permeate is corrosive to downstream piping and appurtenances, alkalinity and pH adjustments are accomplished with bases such as sodium hydroxide, and inhibitors may also be employed for corrosion control purposes.

There is also an issue regarding potential anthropogenic pollutants from a range of sources, which need to be considered on a local basis, whenever any external and potentially minimally treated source is used, taking into account potential pollution sources and threats. Disinfection and filtration of the blending water will be necessary if there is any possibility of microbiological or other regulated parameter contamination, in which case similar considerations regarding the formation of by-products in the blending water apply.

Generally the natural organic matter or TOC content in finished water is very low and the yield of by-products from final disinfection would be expected to be low as a consequence (McGuire Environmental 2004). However, blending with other source waters can prove to be problematic for desalted permeate, should bromide and iodide be present, or should the blend not provide enough buffering to the desalted permeate resulting in an unstable finished water.

#### *Chemicals and Post-treatment Issues*

Post-treatment may be achieved by the addition of chemicals as described in the literature. If this is undertaken there are three primary concerns that need to be addressed:

- a) The quality of the additives and the introduction of chemical contaminants produced during the manufacture, storage, distribution and transport. Unlike pre-treatment chemicals, there are no downstream processes that will remove undesirable contaminants.

- b) Controlling dose rates so that required concentrations are provided.
- c) Preventing or minimizing unwanted chemical reactions following chemical addition. This issue is similar to blending. Localized changes can occur at dosing points leading to fouling problems on a micro-scale.

#### *Brackish and Sea Water Post-treatment*

Post-treatment of the permeate water from the desalination processes can include several unit operations, each dependent upon the source water type and desalination method.

Considerations of post-treatment, based on literature findings, will include:

- Stabilization by addition of carbonate alkalinity; corrosion inhibition; remineralization by blending with source water; disinfection and enhanced removal of specific compounds (i.e., boron, silica, NDMA, etc.). Stabilization by addition of calcium carbonate alkalinity is the most widely used approach for corrosion control of metallic pipelines and distribution systems;
- Corrosion inhibition is the most popular post-treatment method for plastic pipelines and distribution systems;
- Sodium hypochlorite and chlorine gas are most widely used for disinfection of desalinated water;
- Use of chloramines instead of chlorine for disinfection is more advantageous when product water must be conveyed over long distances (over 100 km) or stored for long periods of time (several days) due to the significantly lower decay rate of chloramines compared to free chlorine.

- Use of ozone as a disinfectant for desalinated water has the potential of forming disinfection by-products and bromate.
- Blending of desalinated water for re-mineralization is suitable with brackish water, and only up to about 1% with seawater. The raw water used for blending should be pretreated for chemical and microbial control prior to mixing with the desalinated water.

The primary desalination water plant post-treatment unit operations for potable water supplies reliant upon brackish ground water are the following (AWWA 2007; Duranceau 1993):

- a. Carbon dioxide removal (degasification or decarbonation);
- b. Hydrogen sulfide removal (stripping) and odor control treatment (scrubbing);
- c. Alkalinity recovery, pH adjustment, stabilization and corrosion control; and,
- d. Disinfection.

Alternative treatments reported for use in seawater desalination post-treatment applications include (Withers 2005):

1. Addition of carbon dioxide and excess lime;
2. Filtration of carbon dioxide dosed permeate through limestone bed contactors;
3. Application of sodium carbonate and hydrated lime;
4. Application of sodium bicarbonate and calcium sulfate;
5. Application of sodium bicarbonate and calcium chloride;
6. Blending with a native low-salinity water source or by-pass blending.

Remineralization can be categorized into a series of four treatment processes: (1) chemical addition without lime or limestone; (2) carbon dioxide addition followed by limestone bed contactors for dolomitic dissolution, (3) carbonic acid addition followed by lime dosing; and (4) blending with water containing high mineral content.

### *Identified Water Quality Goals for Post-treatment Processes*

The discussions provided herein this literature review indicate clearly that stabilization and disinfection are fundamentally important in the proper design and operation of post-treatment processes. It is therefore important to develop treatment goals and condition that can be used as a guide for developing post-treatment concepts. Although the development of these goals is site specific to the desalination process and source(s) water(s) used, it has been recommended that the following goals could be used as a guide for desalination post-treatment processes (AWWA 2007; Lahav and Birnhack, 2007):

- Alkalinity  $\geq 80$  mg/L as  $\text{CaCO}_3$
- Calcium between 80 and 100 mg/L as  $\text{CaCO}_3$
- CCPP between 4 and 10 mg/L as  $\text{CaCO}_3$
- Larson ratio  $< 5$

Producing an alkalinity greater than or equal to 80 mg/L as  $\text{CaCO}_3$  has been shown as a goal because it has been suggested by others that alkalinity less than this value is considered low and may result in poor buffering resulting in pH variations in distribution systems (Holm and Schock 1991; Taylor et al. 2005). It should be noted that the TDS content should be similar to other supplies when consecutive distribution systems are impacted by the inclusion of a desalination process into a water community's treatment portfolio. Consideration of a stabilized and disinfected permeate (and its blends) SAR value should be taken into account when water quality goals are to be developed, in addition to possible further consideration of permeate boron when seawater supplies are to be used in a system that includes irrigation as an end-use.

## CHAPTER THREE: PERMEATE POST TREATMENT PRACTICES QUESTIONNAIRE

### Utility Questionnaire

A utility questionnaire was developed and distributed to the fourteen participating utilities in this research project, in addition to many utilities not directly participating in the research workshop. The utility questionnaire was organized using information obtained from the literature review, as well as from individual participant utility phone interviews conducted by UCF. Internet searches of industry, academic and regulatory sources, and organizations aided in identifying additional information, and provided for a basis of other municipal desalination facilities of interest.

The design of the questionnaire included questions relative to post-treatment stabilization options and impacts to the distribution system and water quality data. The questionnaire required documentation of post-treatment quality characteristics, operation information, general capital, and maintenance cost for post-treatment. A total of eight-three questionnaires were distributed, of which twenty-five (30 percent reporting) were returned and used for data analysis based on survey responses by each utility.

A copy of the utility questionnaire presenting each question and requests for specific information is located in Appendix A. The questionnaire was organized and categorized into seven sections:

1. Section I requested general information about the desalting facility (or facilities).
2. Section II requested more specific plant characteristics along with a plant schematic showing pre-treatment and post-treatment processes.
3. Section III was to obtain post-treatment information for each facility with specific information on water quality.

4. Section IV with regard to permeate quality, blend, and point-of-entry (POE) quality.
5. Section V requesting information on post-treatment operation
6. Section VI was designed to obtain information on post-treatment operation and maintenance costs.
7. Section VII was seeking information on lessons learned and/or major issues experienced with respect to post-treatment operations and practices.

### Survey Response

#### *Section I: Background Information*

This section requested respondents to provide their plant name, address, and type as categorized by total dissolved solids (TDS) levels. An additional question asked if the source water was considered as groundwater under the direct influence of surface water (GWUI). Respondents indicated the type of source water their desalination plant processed, with seven categories identified as provided:

1. Seawater [SW]: (20,000 – 35,000 mg/L TDS)
2. High Brackish Groundwater [GW]: (>7,500 - <20,000 mg/L TDS)
3. High Brackish Surface Water [SFW]: (>7,500 - <15,000 mg/L TDS)
4. Low Brackish GW: (1,000 – 5,000 mg/L TDS)
5. Low Brackish SFW: (1,000 – 2,500 mg/L TDS)
6. Fresh GW: (<1,000 mg/L)
7. Fresh SFW: (<1,000 mg/L)

Figure 3-1 presents a distribution that indicated ninety-two percent of the plants used reverse osmosis membranes in their treatment process. The remainder of plants that responded was



divided between EDR and NF. Of those water purveyors reporting, forty-eight percent of the utilities indicated that low brackish GW was the feed water type supplying their desalting process, as indicated in Figure 3-2. None of the responding organizations was classified as either highly brackish groundwater or highly brackish surface water. Twenty percent of the plants reporting indicated that they utilize fresh groundwater, and twelve percent treated seawater. Eight percent of the reporting plants represented low brackish surface water (SFW), and four percent utilized fresh SFW. Eight percent of the respondents reported treating water not listed in the defined categories presented herein.

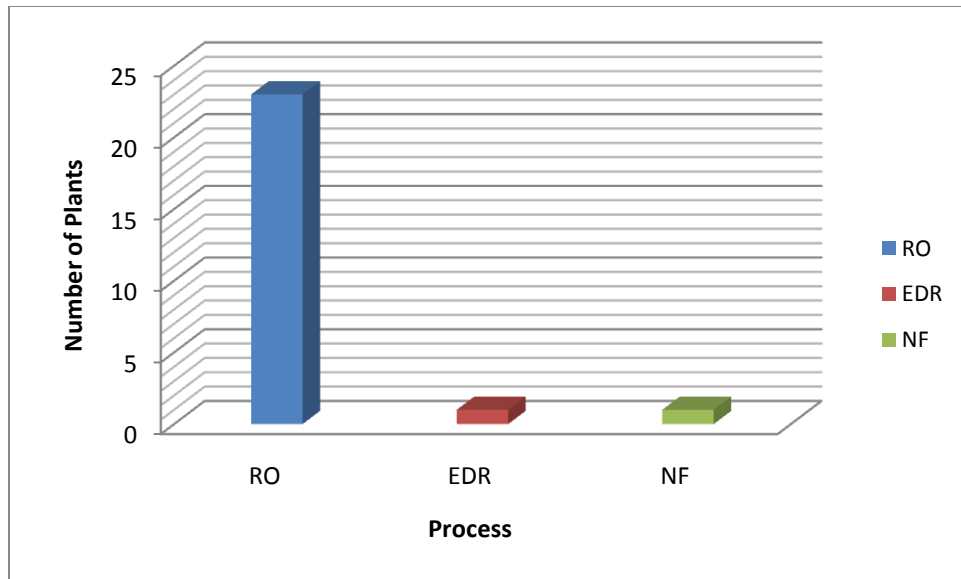

Figure 3-1: Distribution of Plants Surveyed

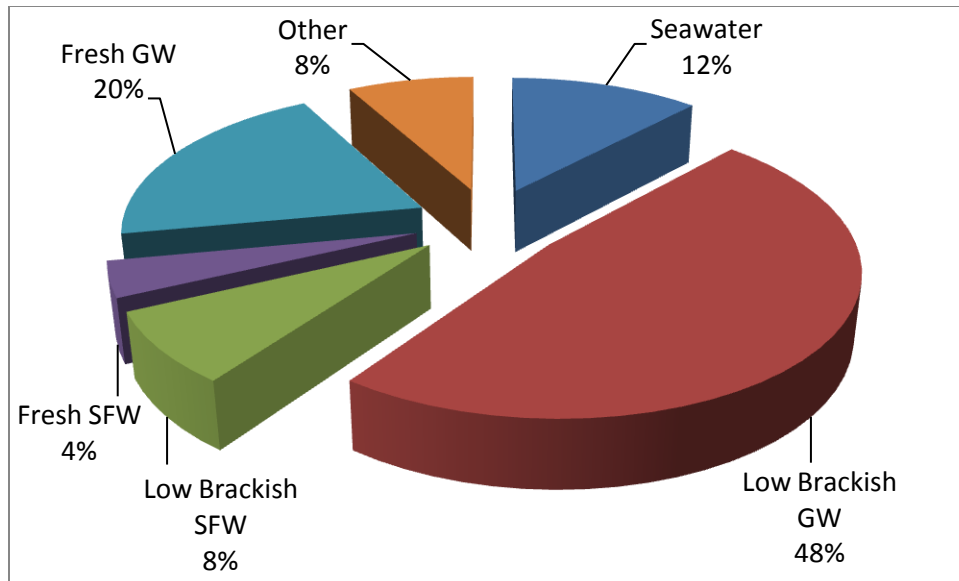

Figure 3-2: Plant Type Categorized by Feedwater TDS

Figure 3-3 shows the percentage of utilities treating water that are considered groundwater under the influence of surface water (GWUI). Twelve percent of the respondents were uncertain if their source water was considered GWUI. Eighty percent of the responding utilities indicated that their ground water was not influenced by groundwater.

Figure 3-4 presents the different types of ownership classification of the respondent utilities, with fifty-six percent of the desalting plants being publicly owned water treatment facilities, and an additional twenty percent of the utilities reported to be classified as a water authority. An additional twenty percent of the utilities responding were classified as other. Only four percent of the surveyed groups could be considered private. One component of the questionnaire was designed to determine what water quality drivers for the use of desalination treatment. Those surveyed were requested to provide information on what specific water quality parameter or combination of water quality parameters drove the decision for the use of their desalination process for water treatment, further defining the type of TDS that was being treated.

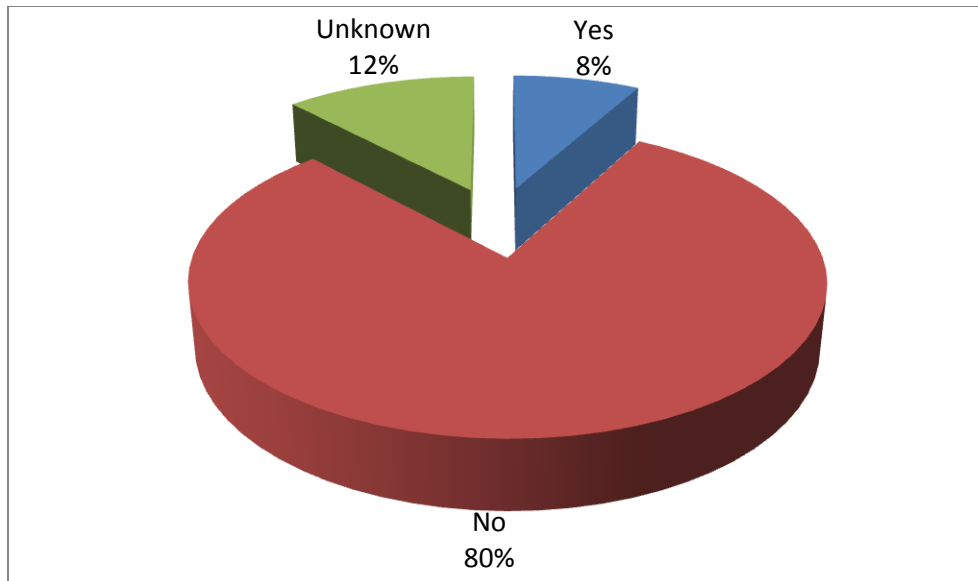

Figure 3-3: Is Your Groundwater Under the Influence of Surface Water?

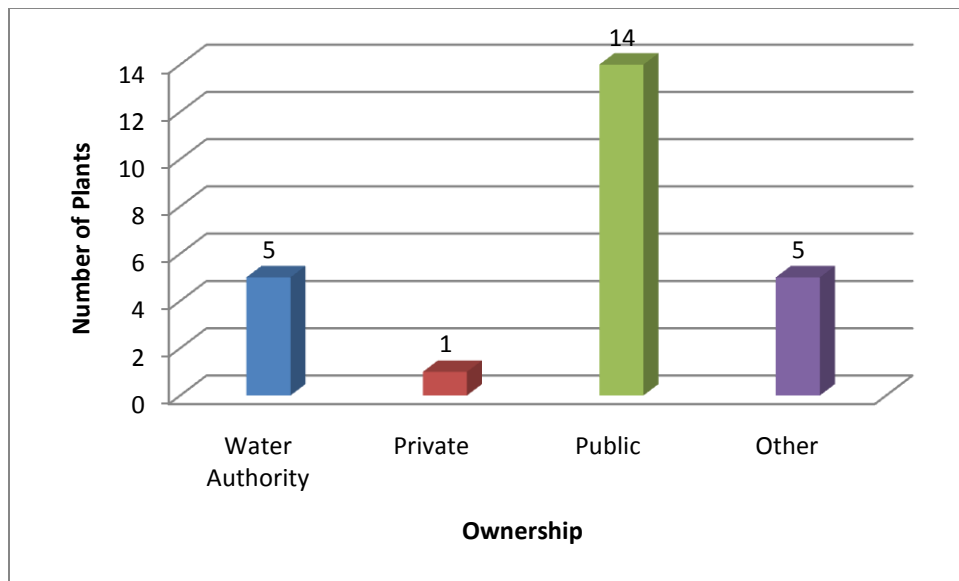

Figure 3-4: Type of Ownership

As shown in Figure 3-5, of the twenty-five reporting utilities, sixty-eight percent of the plants listed salt removal as the major water quality driver. In addition, hardness removal was identified by sixty-four percent of the respondents as a major water quality driver, whereas twenty-four percent of the facilities listed total organic carbon (TOC). A portion of the respondents reported that some other driver was responsible for the decision to use a desalting process, and none reported the use of the technology for synthetic organic compound (SOC) removal

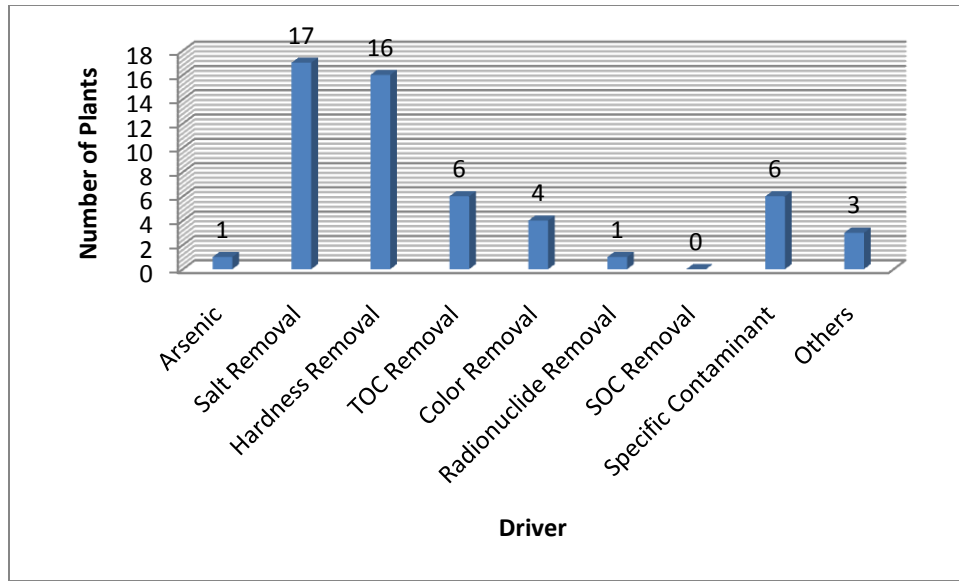

Figure 3-5: Water Quality Driver

*Section II: Plant Characteristics*

Concerning plant characteristics, evaluation of the responses revealed that seventy-two percent of the plants had a design hydraulic capacity between one and fifteen million gallons per day (MGD). Detailed representations are shown in Figure 3-6, where twelve percent of the respondents had design hydraulic capacities of less than one MGD, yet sixteen percent were greater than 15 MGD

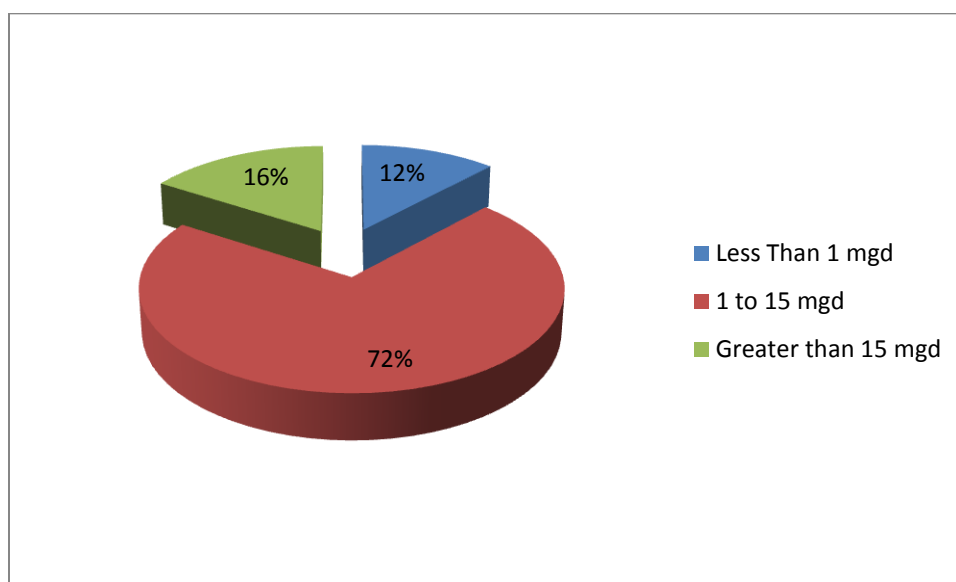

Figure 3-6: Hydraulic Capacity

Seventy-two percent of the utilities indicated that their facility had a design that called for an expansion, as indicated in Figure 3-7; and, the remainder reported they did not have a design that included an expansion. Reported values for the feed water recovery is shown in Figure 3-8, and ranged from 20 to 95 percent recovery. From the graph, it can be seen that most RO facilities have an average feed water recovery between seventy to ninety percent. As reported, a majority of the facilities reported low brackish groundwater as the source water. The NF facility percent recovery range was 90%, which is in the typical range of 85% to 90% recovery. The normal range for EDR

process percent recovery is 75% to 90%, the value reported for the EDR plant was approximately 25%, which is well below the normal range.

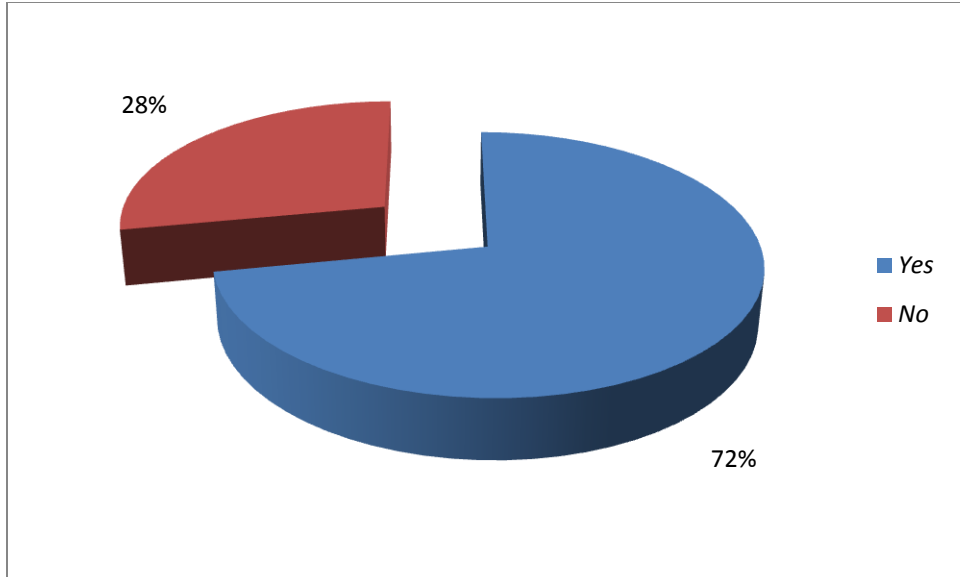

Figure 3-7: Plant Originally Designed for Expansion

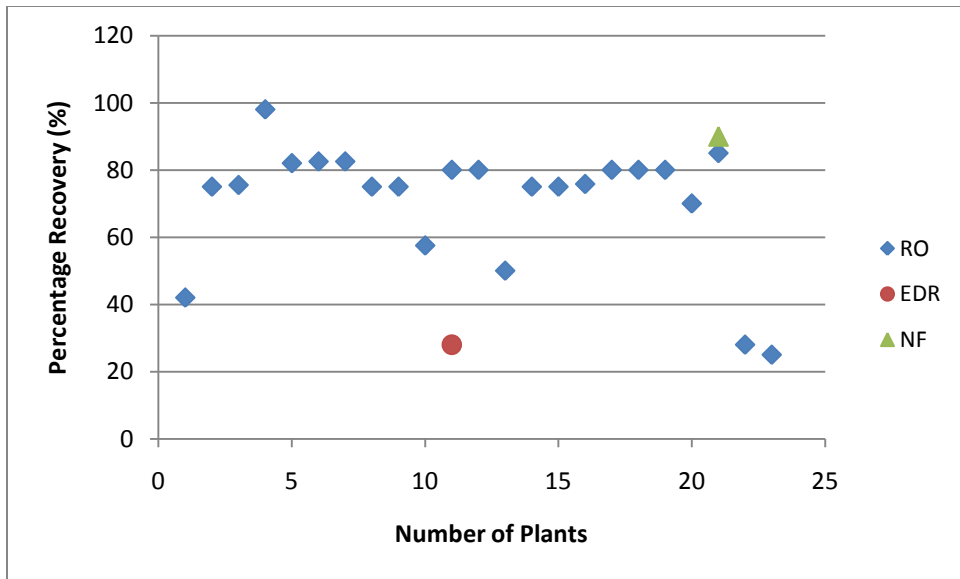

Figure 3-8: Design Percent RO Feedwater Recovery

The design RO membrane flux for each facility was collected and shown in Figure 3-9. Many facilities reported a membrane flux (rate of finished water permeate per unit membrane surface) that ranged from ten to twenty gallons per day per square feet (GFD/ft<sup>2</sup>) of membrane. Responses for nine utilities were not included because data was omitted in their submittals. Figure 3-10 provides design pressure of the respondents, with an average maximum pressure of 312 psi and an average minimum pressure of 205 psi. Typically, brackish RO membrane processes have a design pressure of 100 to 300 psi.

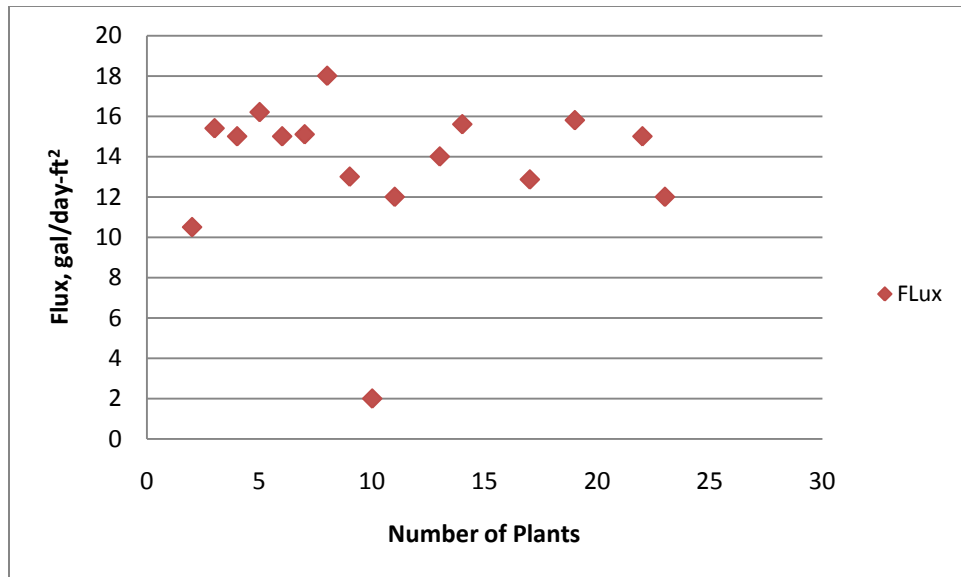

Figure 3-9: Design RO Membrane Flux

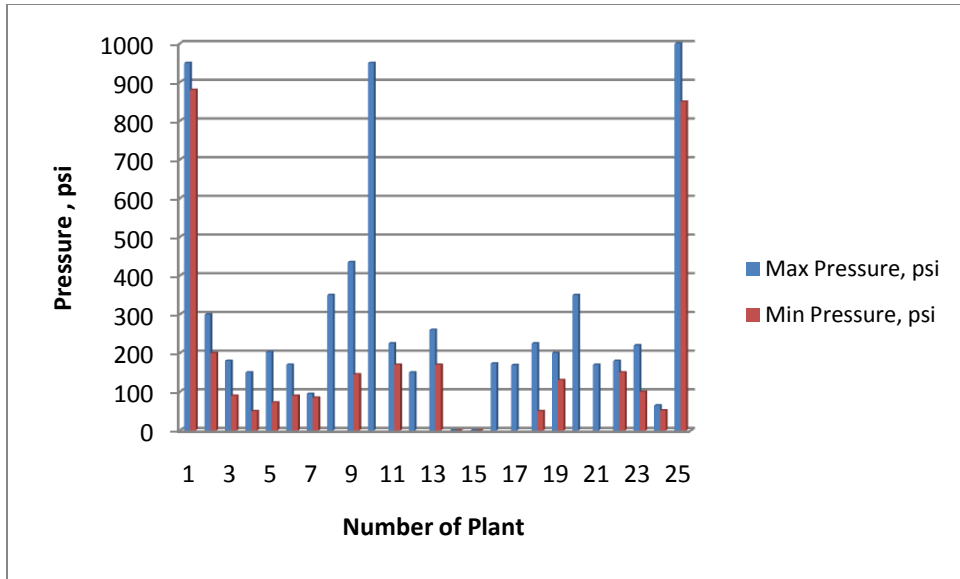

Figure 3-10: Design Pressure

Each facility was requested to indicate the end use of permeate, as shown in Figure 3-11. Most plants (seventy-seven percent) reported only one end use of the permeate water, that being potable water, with only a few plants reporting alternative end-uses, seven percent of which included irrigation and six percent listing an industrial end-use. Three percent of the respondents reported ground water as a seawater intrusion barrier. Distribution of source water for the facility for each survey respondent can be seen in Figure 3-12. Approximately fifty percent of the plants reported brackish water well for their source water.



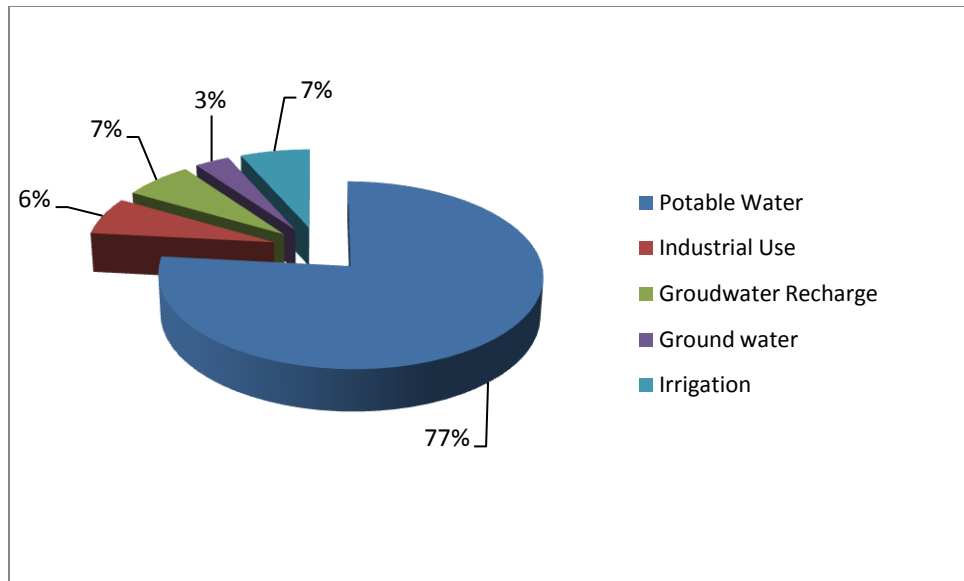

Figure 3-11: Permeate Water End-Use

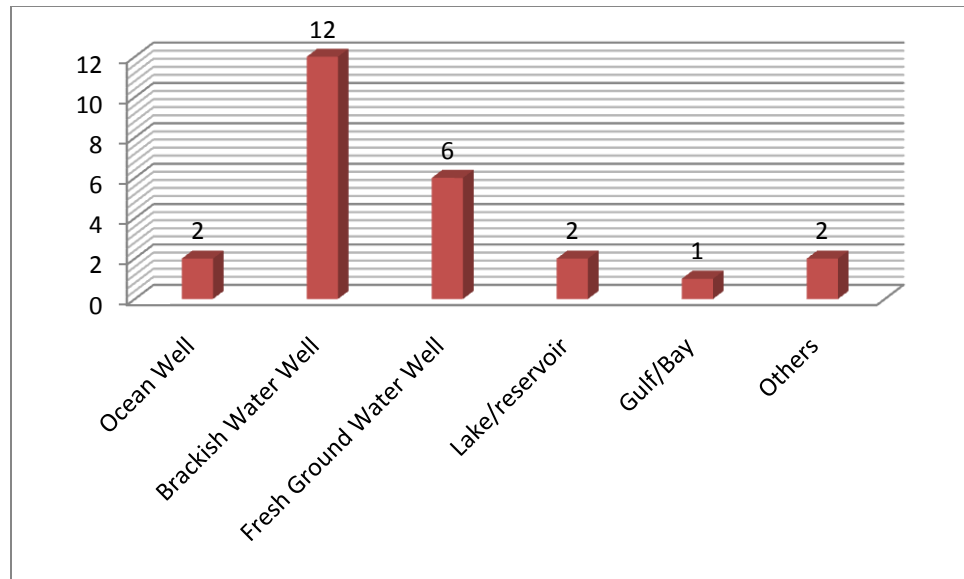

Figure 3-12: Source Water

### *Section III: Post-treatment Information*

Table 3-1 summarizes findings related to post-treatment types and associated disinfection practices. Regarding post-treatment, seventy-two percent of the plants used caustic chemical addition and sixty-four percent rely on blending. Most plants used a combination of disinfection practices for post-treatment. For primary disinfection, sixty-eight percent of the plants use chlorine addition and for secondary treatment forty-four percent of the plants implemented chloramines. None of the respondents used ozone. Table 3-2 details the response given by the facilities in regards post-treatment disinfection and residual goals at the facility. Disinfection chemicals reported to be used include free chlorine and chloramines. Goals for free chlorine leaving the facilities ranged from 0.5 mg/L to 4 mg/L. Log removal of contaminants ranged from 3 to 4 log removal, representing 99.9% to 99.99% reduction of contaminants. Residual goals ranged from 2-4 mg/L.

Table 3-1: Post-treatment Types and Disinfection

Number	Question	Response	
		Yes	No
1	<b>Post-treatment Type:</b>		
	Air Stripping	28%	72%
	Degasification	64%	36%
	Caustic Chemical Addition	72%	28%
	Corrosion Inhibitor Addition	32%	68%
	Blending	64%	36%
	Treated SW	12%	88%
	Treated GW	36%	64%
	Other	36%	64%
2	<b>Disinfection: Primary</b>		
	Chlorine	68%	32%
	Ozone	0%	100%
	UV	8%	92%
	Chlorine Dioxide	4%	96%
	Other	20%	80%
	<b>Disinfection: Secondary</b>		
	Chlorine	12%	88%
	Chloramines	44%	56%
Other	4%	96%	

Table 3-2: Post-treatment Disinfection and Disinfection Residual Goals

Surveyed Utility	Comments
1. Consolidated Water Company, Cayman Islands	0.25 ppm free chlorine residual
2. Town of Jupiter Utilities, Jupiter Florida	3.5 mg/L POE residuals 4 log virus removal
3. Irvine Desalter Primary Treatment Plant	2-5 mg/L combined chlorine at POE 1.0 mg/l minimum in distribution system
4. Deep Aquifer Treatment Systems	0.5 mg/L free chlorine leaving DATS 1.0 mg/l free chlorine in transmission main 2.5 mg/L chloramines entering distribution system 1.0 mg/L chloramines minimum in distribution system
5. Water Treatment Plant Heemskerk	0.5 ppm chlorine dioxide
6. Kay Bailey Hutchinson Desalination Plant	1.0 mg/L
7. City of Pompano Beach WTP	4.0 mg/L chloramines leaving the facility 1.0 mg/L of chloramines residual at the extremities of the distribution system
8. NSA Signonella	1.0 mg/L
9. NSA Naples	2.0 ppm in the finished water tank
10. Tampa Bay Water Seawater Desalination Plant	4.0 mg/l free chlorine 4.0 mg/L Chloramines
11. Edward C. Little Water Recycling Plant-EDR	3 log removal
12. Plant 2	1.5 ppm
13. City of Fort Myers	2.5 to 3 ppm free chlorine
14. City of Venice R.O Plant	Finished water (permeate + blend) is dosed with 4 mg/L 12% Sodium Hypochlorite to maintain approximate 1.5 mg/L free Cl <sub>2</sub> residual
15. Charlotte Harbor Water Association	1.4 ppm chlorine residual 4-log removal
16. City of Sarasota	1.8 mg/l free
17. City of Clearwater R.O Plant 1	4 mg/L chloramines Free N<.1
18. City of Miramar West Membrane Treatment	3 to3.2 free residual at clearwell
19. Richard A. Reynolds Desalination Facility	2 to 3 mg/L total chlorine
20. City of Hollywood WTP-RO	3.0 ppm residuals 4 log removal
21. City of Hollywood WTP-NF	3.0 ppm residual 4 log removal
22. Charlotte County Utilities: Brunt Store Water Plant	3.2 and .7 mg/L
23. Advanced Water Purification Facility	Non detect total and fecal coliform
24. Charles E. Engleman-EDR	1.2 mg/L
25. FKAA Stock Island R.O Plant	3.5 mg/L total

Table 3-3 indicates that there were plants that believed they had significant problems with post-treatment. Twenty percent of the plants identified biological growth in degasification and stripping towers as a problem. Distribution impacts for each plant are presented in Table 3-4. Of the plants surveyed, twenty-four percent of the responding parties reported that they had experienced red water or black water events.

Table 3-3: Have you experienced any post-treatment problems within the plant?

Number	Question	Response	
		Yes	No
4	<b>Have you experienced any post-treatment problems within the plant?</b>		
	Blending Limitations	8%	92%
	Scaling of Degasification/stripping towers	16%	84%
	Biological growth in Degasification/stripping towers	20%	80%
	Chemical Injector plugging	16%	84%
	Issues with Cleaning Post-treatment Equipment	0%	100%
	White Water formation	4%	96%
	Corrosion Events	12%	88%
	Colored or red water	16%	84%
	Others	20%	80%

Table 3-4: Any distribution system impacts noted?

Number	Question	Response	
		Yes	No
5	<b>Any distribution system impacts noted?</b>		
	Corrosion events (infrastructure)	16%	84%
	Lead and Copper Rule Impacts	4%	96%
	Disinfection By-Products	4%	96%
	Taste and Odor	0%	100%
	Detention time prior to point of entry	4%	96%
	Detention time after point of entry	0%	100%
	pH stability	16%	84%
	Disinfection residual stability	20%	80%
	White water	0%	100%
	Color	12%	88%
	Red water/black water	24%	76%
	Biological regrowth	12%	88%
	Others	12%	88%

Table 3-5 lists descriptions given by the facilities with responses describing their blending or by-pass process. From the descriptions provided it is apparent most facilities incorporated form of blending or bypass for post-treatment processing of permeate water.

Table 3-6 lists the detailed description given by the facilities with response describing their sequence of post-treatment operations. With regards to the sequence of post-treatment operations respondent facilities detailed descriptions were provided. The sequence of post-treatment varied for each facility. Most facilities utilized blending, ph adjustment using CO<sub>2</sub> or NaOH. Desgasifiers were used for gas removal, and for disinfection chorine or chloramines addition was utilized.

Table 3-5: Blending or By-Pass Descriptions

Surveyed Utility	Comments
1. Consolidated Water Company, Cayman Islands	Not Reported
2. Town of Jupiter Utilities, Jupiter Florida	Lime softened and ion exchange water is blended with RO permeate
3. Irvine Desalter Primary Treatment Plant	RO permeate produced goes through decarbonation and is then blended with raw groundwater
4. Deep Aquifer Treatment Systems	Blend concentrate treatment system NF permeate with Deep Aquifer Treatment System NF permeate. The combined flow s blend with untreated , disinfected groundwater in the transmission main
5. Water Treatment Plant Heemskerk	Ration WTP Mensink = 7 Mm3/y to 30.09Mm3/y variable; Ratio WTP Bergen = 9.2 Mm3/y to 13.68 Mm3/y fixed on TH = 1.5 mmol/L
6. Kay Bailey Hutchinson Desalination Plant	Permeate blended with brackish feed water
7. City of Pompano Beach WTP	Marginal Bleeding occurs in two clear wells and is not adequate.
8. NSA Signonella	Adjust hardness and alkalinity
9. NSA Naples	Blending water is filtered by Granular Activated Carbon filter then blended with RO permeate (manually control)
10 Tampa Bay Water Seawater Desalination Plant	Finished water from seawater desalination plant blends with finished water from the regional SWTP. The blended product if adjusted for finished pH and alkalinity then blends with groundwater
11. Edward C. Little Water Recycling Plant	Seventy percent post RO water goes to Decarbonation Towers-30% by passes
12. Plant 2	Blend up to 5% to add back some fluoride
13. City of Fort Myers	By-pass 10% raw water through a cartridge filter into the product water
14. City of Venice R.O Plant	Six Percent of raw water is by-passed through 5 micron cartridge filters and blended with product water stream prior to degasification and post-treatment
15. Charlotte Harbor Water Association	Filtered with sand separators and micron filters has been treated with anti-scalant
16. City of Sarasota	RO product water blended with ion exchange treated raw water raw water which has be degasified and chlorinated to breakpoint
17. City of Clearwater R.O Plant 1	Thirty-three percent of filtered effluent is blended with permeate for stabilization. Fifty percent sodium hydroxide is added to permeate for pH adjustment
18. City of Miramar West Membrane Treatment	Not Reported
19. Richard A. Reynolds Desalination Facility	Raw bypass water is blended with permeate following the degasifiers but before chlorine and caustic addition
20. City of Hollywood WTP-RO	Finished water product form (Lime softening, RO, NF) is blended together on one blend tank and then pumped to onsite storage tanks. Cl <sub>2</sub> , Caustic, and Fluoride are added in blend tank
21. City of Hollywood WTP-NF	Finished product water from (Lime Softening, NF, RO) is blended is and the pumped to onsite storage tank
22. Charlotte County Utilities: Brunt Store WTP	Blend water is filtered raw water after the pre-filters. Blend 10% of the total permeate gallons from the RO units
23. Advanced Water Purification Facility	After RO there is a partial bypass of flow around decarbonation with majority sent to decarbonation towers
24. Charles E. Engleman-EDR	No Response
25. FKAA Stock Island R.O Plant	No Response

Table 3-6: Sequence of Post-treatment Operations

Surveyed Utility	Comment
1. Consolidated Water Company, Cayman Islands	Degasification, sodium hydroxide for pH-adjustment, disinfection using calcium hypochlorite
2. Town of Jupiter Utilities, Jupiter Florida	pH adjustment, degasification, chlorination, ammonization, blending
3. Irvine Desalter Primary Treatment Plant	Decarbonation, blend with sequestering agent caustic, disinfection
4. Deep Aquifer Treatment Systems	Free Chlorine and degasification
5. Water Treatment Plant Heemskerk	CO <sub>2</sub> dosage followed by NaOH to form HCO <sub>3</sub> , transport, blending, pH correction with NaOH or CO <sub>2</sub> , ClO <sub>2</sub> dosage distribution
6. Kay Bailey Hutchinson Desalination Plant	Blending, pH control, disinfection, corrosion control
7. City of Pompano Beach WTP	Addition of corrosion inhibitors, degasification, addition of caustic and some blending
8. NSA Signonella	NaOH then NaOCL
9. NSA Naples	Add NaOH the NaOCL
10. Tampa Bay Water Seawater Desalination Plant	CO <sub>2</sub> followed by saturated lime injection, then final disinfection with free chlorine (sodium hypochlorite)
11. Edward C. Little Water Recycling Plant	Barrier Injection= peroxide, UV, Decarbonation, lime, storage. Industrial Use=Decarbonation , 2nd pas RO (for some water) to industry
12. Plant 2	Calcium Chloride, chloramines
13. City of Fort Myers	Degasifiers, clear well CO <sub>2</sub> addition, caustic addition, blend corrosion inhibitor, Fluoride
14. City of Venice R.O Plant	Product stream blended w 6% raw water addition of CO <sub>2</sub> , degasification, Cl <sub>2</sub> to NaOH for pH adjustment and zinc ortho-PO <sub>4</sub> for corrosion control
15. Charlotte Harbor Water Association	Blend, degasification, chlorine and soda addition
16. City of Sarasota	Degasification, NaOH addition, Chlorine addition
17. City of Clearwater R.O Plant 1	Blend filtered/permeate and add free chlorine for .5 to .8 ppm dose; blend water enters 5 mg GST; Post disinfection is chloramination
18. City of Miramar West Membrane Treatment	Chemical feed to clear well offsite storage tank with Cl <sub>2</sub> booster
19. Richard A. Reynolds Desalination Facility	Degasifiers, blend, chlorine(hypo caustic agent and blend ahead of blend point) chlorine contact tank (2-4 hrs), ammonia, high lift pumps, distribution
20. City of Hollywood WTP-RO	Permeate water from the RO plant is sent to a Degasifier and the H <sub>2</sub> S gas goes through a scrubber. The finished water then goes to the blend tank
21. City of Hollywood WTP--NF	Permeate from the membrane plant is sent to a degasifier and then to the blend tank where it is blended and caustic sodium hypochlorite, and Florida is added
22. Charlotte County Utilities: Brunt Store WTP	Degasification, sodium hydroxide injection, sodium hypochlorite injection, clear well water pumped to GST's
23. Advanced Water Purification Facility	Take blend of fully and partially decarbonated RO product water and add lime solution. Lime solution by adding powdered form hydrated lime (CaOH) to decarbonated RO water in a slurry unit tank and sending slurry to a saturator. Saturator supernatant drawn off for addition to plant effluent water
24. Charles E. Engleman-EDR	Raise pH with NaOH
25. FKAA Stock Island R.O Plant	Degasification, NaOH addition, NH <sub>3</sub> , Cl for disinfection



Table 3-7 shows that pH adjustment is the most common method for addressing stabilization and corrosion control for the utilities surveyed. Table 3-8 shows the responses on what was their method for corrosion control. Eighty percent of the plants listed pH adjustment as their method for corrosion control; and blending represents sixty percent. Most plants did incorporate two or more methods for corrosion control in their facility.

Table 3-7: Control of pH and Buffering Content on Post-treatment

Surveyed Utility	Comment
1. Consolidated Water Company, Cayman Islands	-
2. Town of Jupiter Utilities, Jupiter Florida	Addition of NaOH and blending of water of low color and moderate hardness
3. Irvine Desalter Primary Treatment Plant	Decarbonation, blend with sequestering agent, caustic, disinfection
4. Deep Aquifer Treatment Systems	Water is well buffered, membranes don't remove inorganic material, not required
5. Water Treatment Plant Heemskerk	Online measurements of pH controlling CO <sub>2</sub> and NaOH dosage
6. Kay Bailey Hutchinson Desalination Plant	Only addition of poly-orthophosphate
7. City of Pompano Beach WTP	Degasification, pH adjustment, some blending and addition of corrosion inhibitor
8. NSA Signonella	NaOH adjusting pH to 7.2
9. NSA Naples	In line pH meter and conductivity
10. Tampa Bay Water Seawater Desalination Plant	Yes, pH/ alkalinity adjustment facility
11. Edward C. Little Water Recycling Plant	Lime Addition and decarbonation towers.
12. Plant 2	-
13. City of Fort Myers	Addition of CO <sub>2</sub> then caustic alkalinity at 30 ppm
14. City of Venice R.O Plant	Addition of CO <sub>2</sub> and 50% NaOH
15. Charlotte Harbor Water Association	Soda ash only
16. City of Sarasota	pH control with caustic and blending Verna well water. The Verna water is treated through an ion exchange system and also blended raw.
17. City of Clearwater R.O Plant 1	50% caustic from pH adjustment; 33% blend ratio for stabilization
18. City of Miramar West Membrane Treatment	Caustic Soda
19. Richard A. Reynolds Desalination Facility	With raw blend and caustic
20. City of Hollywood WTP-RO	pH is raised by blending with water from the lime softening plant and caustic soda
21. City of Hollywood WTP-NF	pH is raised by blending the water with the lime softening plant and adding caustic soda
22. Charlotte County Utilities: Brunt Store WTP	Clear well target range of 8.2 to 8.5 for the pH. Sodium hydroxide metering pump is adjusted accordingly by the operators to maintain that range for pH
23. Advanced Water Purification Facility	Use hydrated lime (CaOH) made into a solution via slurry mix system. Also, pH is controlled by controlling amount of bypass around decarbonation process
24. Charles E. Engleman	Raise the pH with caustic soda addition
25. FKAA Stock Island R.O Plant	NaOH addition

Table 3-8: Describe your Method of Corrosion Control

Number	Question	Response		
		Yes	No	No Response
10	<b>Describe your method of corrosion control</b>			
	pH Adjustment	80%	16%	4%
	Alkalinity Adjustments	24%	72%	4%
	Hardness Adjustments	20%	76%	4%
	Corrosion Inhibitor	28%	68%	4%
	Blending	60%	36%	4%
	Others	4%	92%	4%

*Section IV: Post-treatment Water Quality*

A portion of the questionnaire was designed to collect water quality information as related to membrane processes post-treatment applications. Water quality parameters of most interest in the survey included general water quality parameters, metals, and microbiological parameters. The membrane facilities were requested to provide water quality information regarding RO permeate, blend water, and the point-of-entry (POE) to the distribution system. Low, high, and average parameter values were requested to be provided by each respondee. A majority of the plants responding reported average values; subsequently, the average values provided by the responding utilities were those used in data analysis. For those facilities that did not report average values, available data or that, data reported as the high value were relied upon used for data analysis.

Figure 3-13 presents a plot of the average temperature, pH, and alkalinity. A review of the collected information shows that the average pH and temperature of the permeate, blended water and finished water delivered to the point-of-entry (POE) to the distribution system do not change significantly across unit operations. However, the alkalinity of the blend water is appreciably different than the permeate and POE data reviewed. This is most likely because the blend water is

derived either from the raw water source or from another source that contains appreciable levels of alkalinity that has not been removed or is low in pH containing predominantly carbonic acid instead of carbonate alkalinity. Use of blend water to increase the alkalinity of the permeate water prior to distribution at the POE is typical for corrosion control and stabilization purposes. As a result, alkalinity is highest for the blend water, which is approximately 142 mg/L as CaCO<sub>3</sub>. Alkalinity at the POE averaged at least one milli-equivalent, or 60 mg/L as CaCO<sub>3</sub>, which is an important consideration for post-treatment stability. The dataset appears to agree with industry trends that target a minimum of one milli-equivalent of alkalinity as CaCO<sub>3</sub> provides sufficient buffering for the distribution system.

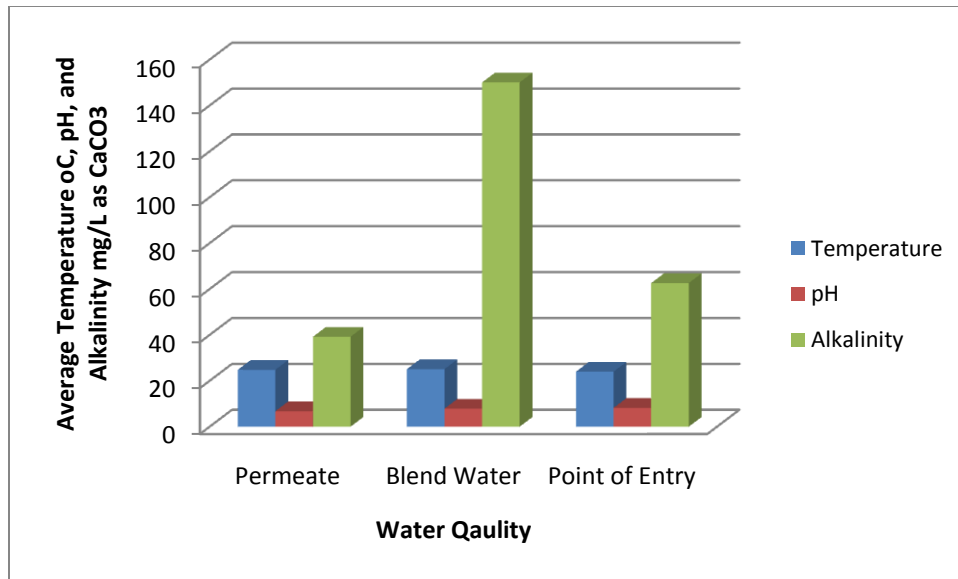

Figure 3-13: Average Temperature, pH, and Alkalinity for Permeate, Blend, and Point of Entry

Figure 3-14 presents a graphical summary of the reported average turbidity and color data for the permeate, blend, and POE water sample locations. The data indicates that the turbidity, although low for permeate, is actually lowest as identified at the point of entry, which would not be unexpected, particularly if other water plants feed the same POE. In addition, the difference in turbidity between reporting locations is not significantly different when reported as averages, so it is shown that, as would be expected, permeate produces high quality water with respect to turbidity. Although color does vary by location, the difference between the POE (3.5 CPU) and permeate (1.1 CPU) are not significant.

Figure 3-15 is a plot of the average conductivity and TDS for the permeate, blend, and POE sample locations. Note that TDS and conductivity are related; however, care should be taken and specific correlations should not be used for the data presented because averages are presented across many different types of water supplies. The permeate TDS is reported as below the secondary standard of 500 mg/L, one of the goals of most desalination facilities. Conductivity and TDS are greater than the secondary water quality standard in the blend water supply, which is not unreasonable since many plants by-pass the native raw water supply to blend with permeate to add stability economically. The blended water and/or treated water prior to distribution (at the POE) will meet the secondary standard of 500 mg/L, which is reflected in this data being reported.

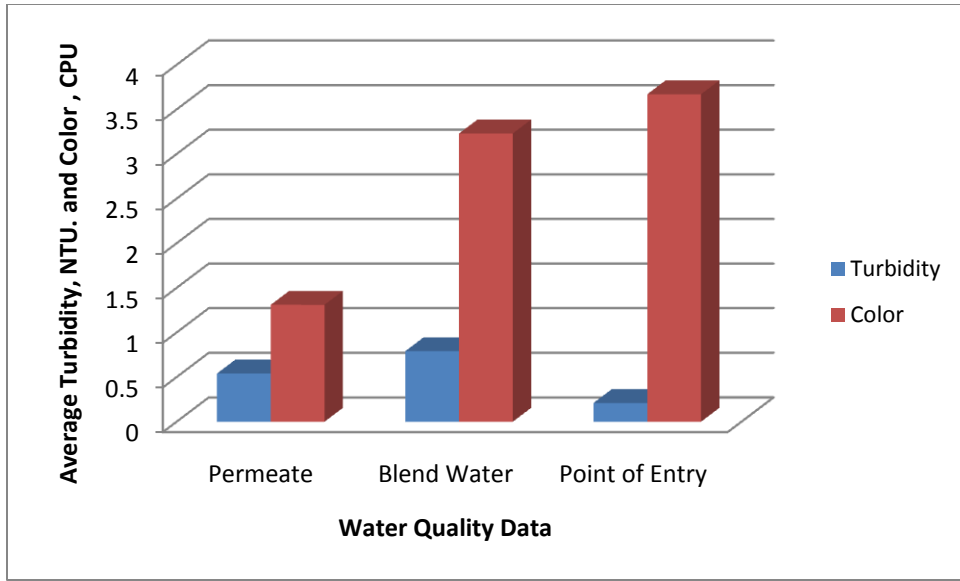

Figure 3-14: Average Turbidity and Color for Permeate, Blend, and Point of Entry

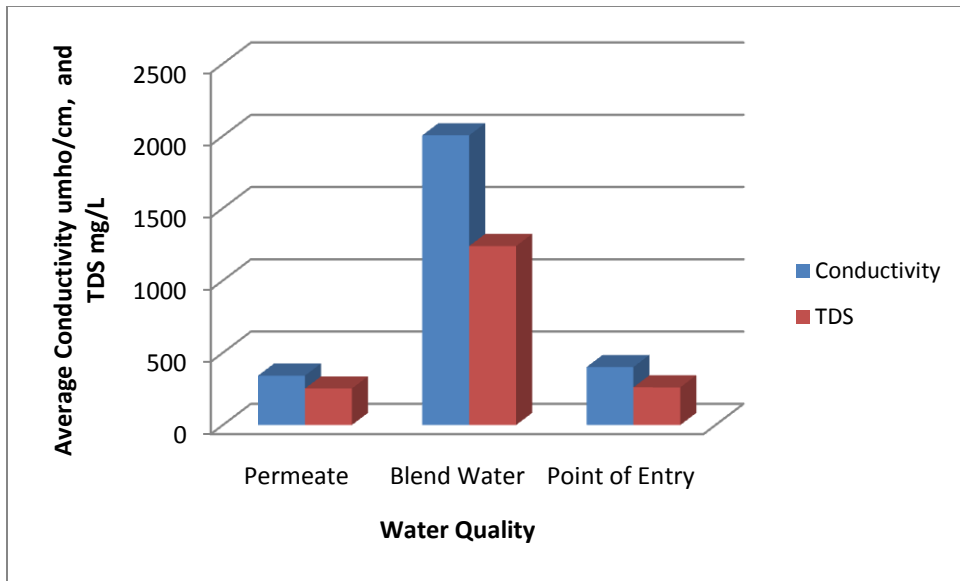

Figure 3-15: Average Conductivity and TDS for Permeate, Blend, and Point of Entry

Table 3-9 provides a list of water quality parameters that were not provided in the returned questionnaire responses. These parameters (or indices) are not typically collected by water plant personnel, and the questionnaire confirmed that many of these parameters are only collected for use in special studies or other non-traditional plant operation protocols. This is not unexpected, but does allow for future consideration with regards to enhanced operations monitoring and improved post-treatment water quality data collection activities that could be recommended to operating personnel of these types of facilities. Enhancements to existing operating methods that would require the addition of several if not all of the parameters listed in Table 3-9 would result in an increase in the overall operating costs of the facilities, which must be considered for economic purposes.

Table 3-9: Water Quality Parameters Not Provided by Respondees to the Questionnaire

<b>Water Quality Parameters</b>
Hydrogen Sulfide
Silica
Bromide
Algae
Heterotropic Plate Count Bacteria
<i>Pseudomonas</i>
Langelier Saturation Index (LSI)
Ryznar Index

Figure 3-16 presents the findings of data collected from utilities responding to the questionnaire that shared information on the permeate water quality. Sodium, calcium, magnesium, sulfate, and chloride information was collected from the facilities that responded to the survey questionnaire. Figure 3-16 illustrates that the permeate quality was predominantly comprised of sodium and chloride for the plants surveyed, and depleted in calcium and magnesium. This would be

expected since the majority of the facilities that responded to the questionnaire utilized reverse osmosis (Figure 3-1) that treated predominantly some form of brackish or seawater supply (Figure 3-2).

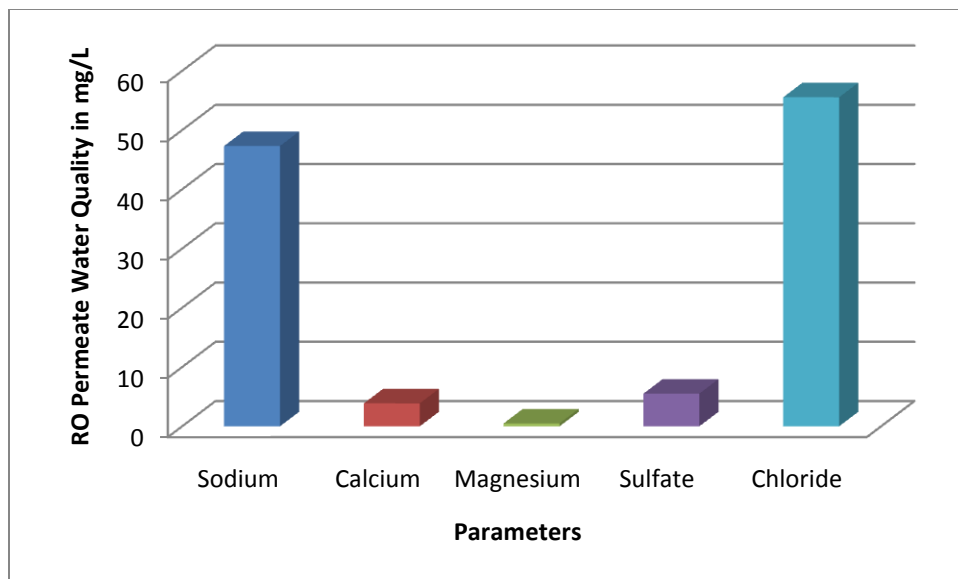

Figure 3-16: RO Permeate Water Quality

In a reverse osmosis process the divalent constituents' calcium, magnesium, and sulfate would be completely rejected by the membrane, resulting in permeate where sodium and chloride would be present in quantities controlled by diffusion through the membrane. However, as presented in Figure 3-17, facilities reporting blend water constituents indicated that calcium, magnesium and strontium were present, in addition to chloride. Chloride appeared to be the controlling ion with regards to the greatest amount present and upon which total dissolved solids content would be based.

Figure 3-18 presents information with respect to several water quality parameters identified at the POE. Sodium, sulfate, and chloride are found to be present in higher concentrations at the POE than other constituents such as potassium, barium, calcium, iron, manganese, phosphate, aluminum, fluoride, and selenium. There is a portion of the respondents reporting magnesium, due

to the blending impacts of by-pass water. A small amount of aluminum is present, representing corrosion by-products of valves, pumps, and appurtenances and not necessarily the by-pass or blend water supplies.

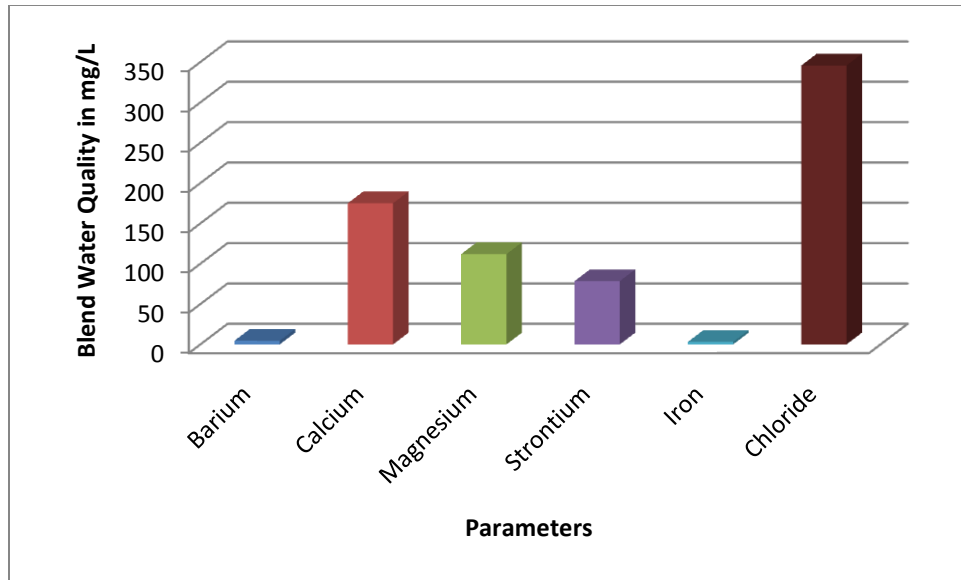

Figure 3-17: Blend Water Quality

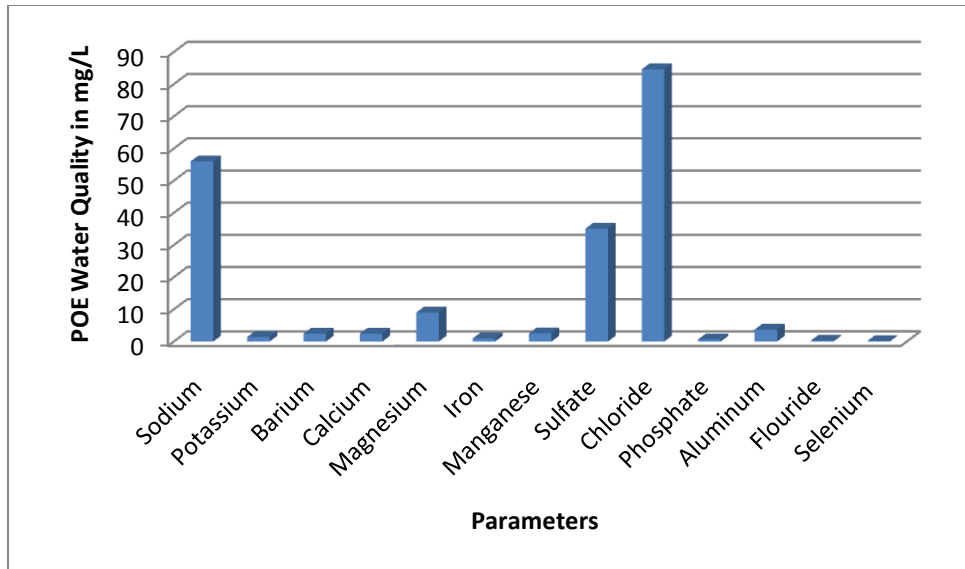

Figure 3-18: Point of Entry (POE) Water Quality



*Section V: Post-treatment Operations*

Several of the responding utilities provided data pertaining to post-treatment operations. Information requested included the average and maximum daily permeate production, in addition to data regarding daily permeate and blend water flow rates. In addition, information regarding post-treatment chemicals and average dosage rates was requested. Blending ratio (as a percentage) and its control also was one component of the post-treatment operations survey. Figure 3-19 shows the frequency distributions of the daily permeate production at facilities reporting flow rates. Plants that did not report data were not evaluated as part of the data set.. Permeate production rates ranged from 0.12 MGD to 70 MGD across the respondents. Blend water flow rates are schematically represented as the frequency chart shown in Figure 3-20. Many of the facilities reporting indicated that a significant amount of flow is blended across the facilities. Of the plants that were surveyed, the highest average flow of the blend water flow was approximately ten million gallons per day.

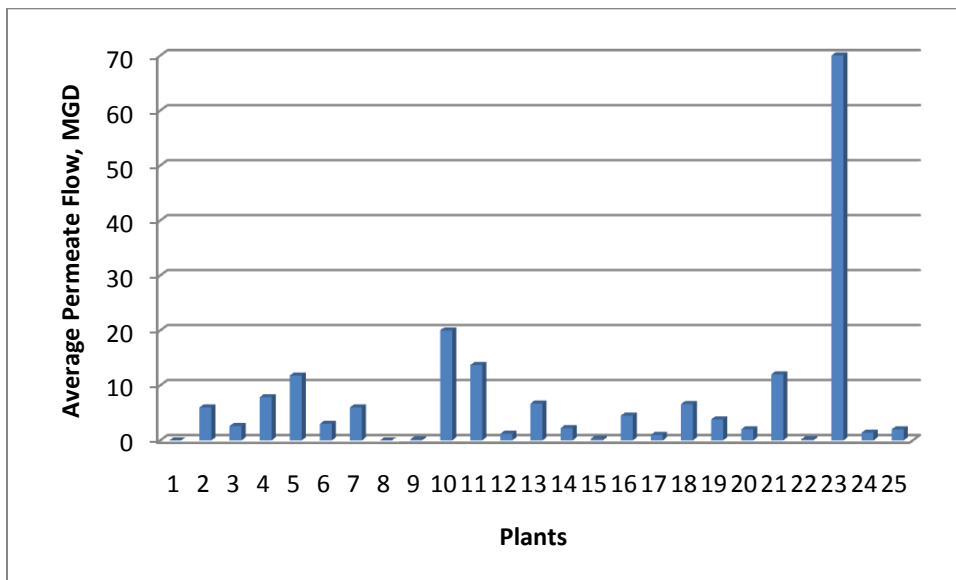

Figure 3-19: Frequency Distribution of the Average Daily NF/RO Permeate Production

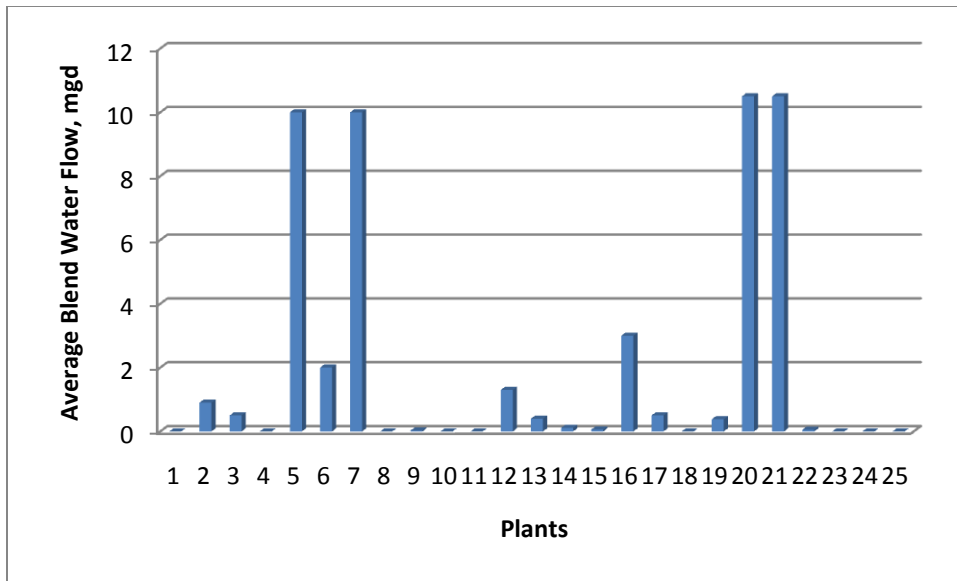

Figure 3-20: Frequency Distribution of Reported Average Blend Flow

*Section VI: Post-treatment O&M Costs*

Operation and maintenance (O&M) costs were collected from each plant and were categorized by plant capacity, labor, chemicals, energy, membrane replacement, replacement parts and concentrate disposal. Figure 3-21 shows a representation of plant capacity versus operation and maintenance cost. There is not a strong correlation with plant capacity and costs given by the facilities, which may indicate that other O&M costs were not provided or shown; however, it is more likely that total O&M costs are provided and not specifically post-treatment O&M costs. Since it is not possible to extract the different costs from that data presented, the information presented in this section should be reviewed with this understanding. It is typical that there is an economy of scale that would be expected for this type of evaluation. Moreover, O&M costs for this evaluation were difficult to analyze because of the various and inconsistent methods the facilities presented their data. For example, O&M cost from a European facility were reported in euro and had to be converted to dollars, using an average rate at the time the data was provided and may not represent

changing interest or other impacts on costs over time. A conversion on \$1.4132 dollars per euro was used for this calculation.

Figure 3-22 is a graph showing plant average O&M cost for labor, chemicals, energy, membrane replacement, replacement parts and concentrate disposal. As expected, the data indicates that labor, chemical and energy costs are the largest contributors to O&M costs. Figure 3-23 shows the average energy cost for each reporting facility based on the plant capacity. Energy costs remained relatively consistent for the facilities that did report data; however, one plant reported a significantly higher energy cost, which may reflect contracted rates or could be due to the small plant size.

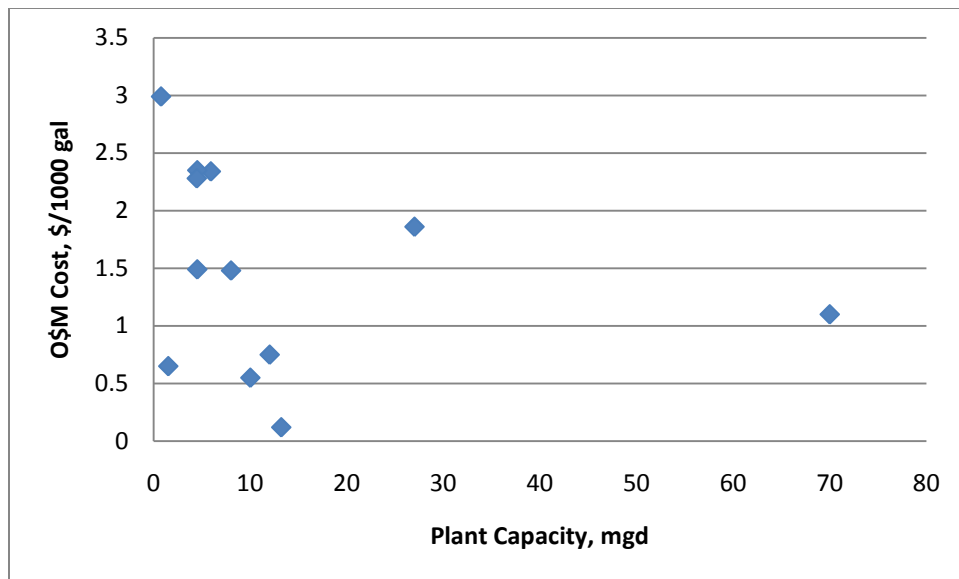

Figure 3-21: Operation and Maintenance Cost versus Plant Capacity

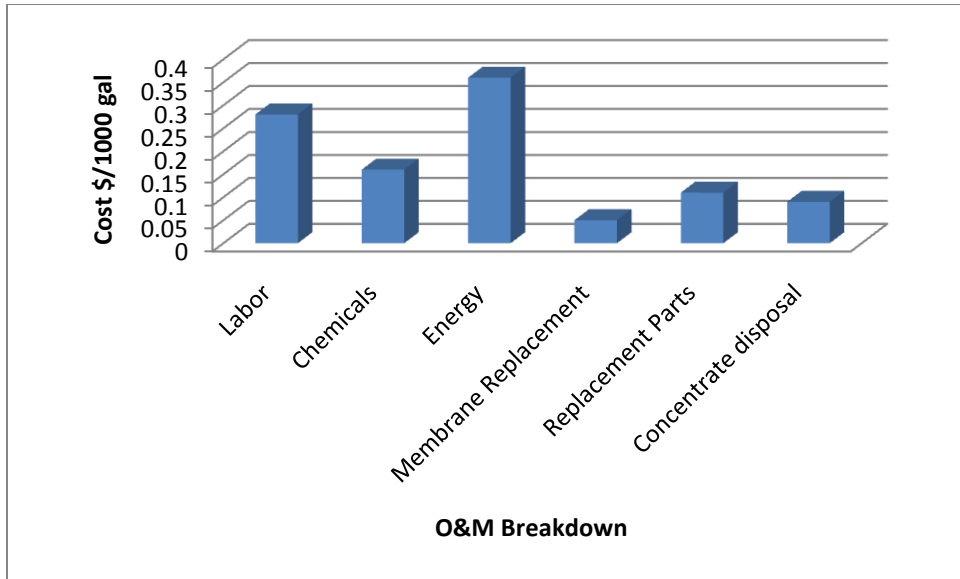

Figure 3-22: Operation and Maintenance Cost Breakdown by Cost Category

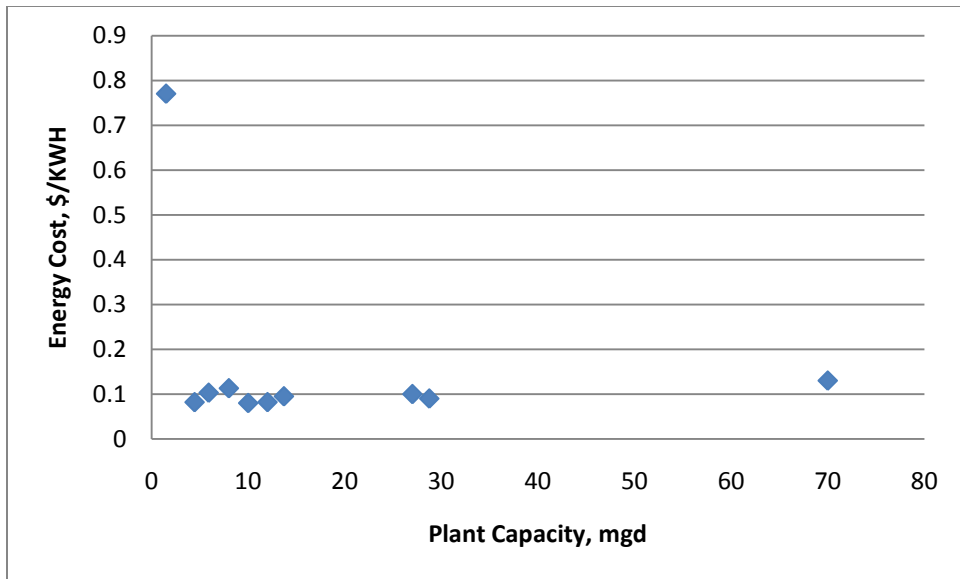

Figure 3-23: Energy cost versus Plant Capacity

### *Section VII: Major Issues and Lessons Learned*

This last section of the survey questionnaire requested respondents to cite details on any identified major issues that their facility experienced regarding post-treatment. In addition, respondents were requested to share any of their lessons learned as a result of operating their membrane facility. To assist the responder in their efforts, specific topics were identified and presented in order to obtain detailed responses to questions concerning to the following:

- Pilot Testing
- Design of the facility
- Permitting/Regulations
- Facility Startup
- Operations

Respondents were asked to reveal if pilot test showed any water quality concerns for the distribution system. Figure 3-24 shows that forty-eight percent of respondents used pilot testing prior to implementing their desalination, which did not reveal any concerns. Twenty-four percent did not answer the question and twenty-eight percent revealed that pilot testing did reveal information that would be a possible concern for their distribution system. Few water authorities pilot both process and distribution system together.

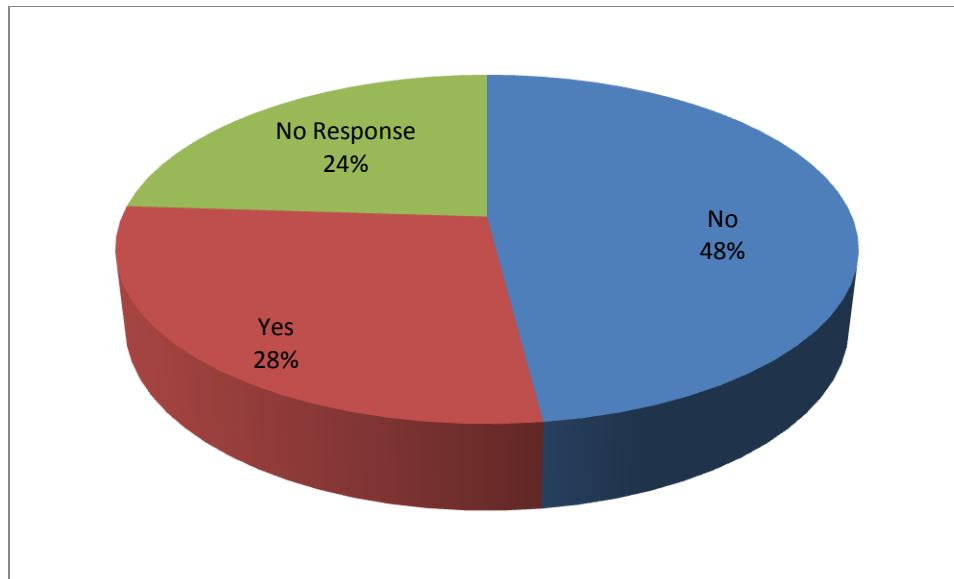

Figure 3-24: Did pilot testing reveal water quality concerns for distribution system?

Respondents noted that pilot testing helped their operation with further understanding issues related to the following:

- 1) What parameters would be of concern regarding post-treatment stabilization of permeate;
- 2) Did the design of the degasifier unit help predict the removal of dissolved gases?
- 3) Were there any blending concerns to be aware of when using a membrane process for salinity or TDS reduction?
- 4) Did coupon testing help predict corrosion control dosages for sizing chemical feed facility designs?

Figure 3-25, however, indicated that forty percent of the responders considered the impact of permeate on the drinking water distribution system, hence, indicating that there are many operating utilities that need to be better informed of the benefits of pilot testing and the importance of understanding how the use of membrane processes, particularly desalination, can impact distribution system water quality.

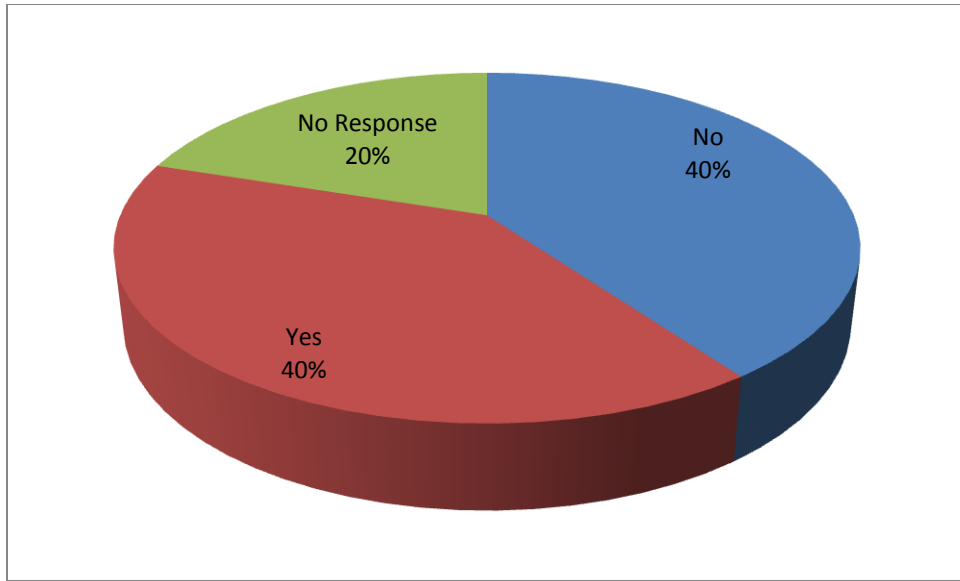

Figure 3-25: Did design of facility consider impacts of permeate on the distribution system?

One of the more important lessons identified by the survey was that pilot testing is an effective way to study the full-scale process and in doing so identify possible problems that may occur with the process well before the scheduled plant startup. Data on water quality can be collected and used to develop effective ways for treating water when issues arise with blending, disinfection, and membrane selection. If effective pilot test was taken into consideration, many problems could be identified and responded to, which would minimize future costs required to address the problem after the plant has been placed on-line.

It was noted by one facility that by not considering the design of post-treatment facilities into full consideration, issues with post-treatment would occur. In addition, another facility reported problems after plant start up with clogging of injection wells, and distribution system impacts due to sulfur residuals. Although details were not provided it is important to stress the need to have an effective design that takes into account post-treatment stabilization of permeate.

Another lesson provided by the respondents was related to the design of the intake facility; that is, an adequate and properly designed intake design will reduce potential impacts within the facility. Effective pre-treatment design should also prevent problems with regard to post-treatment of permeate water particularly if by-pass blending is to be practiced.

Permitting and meeting regulations are other important aspects of implementing and operating a desalination facility. The survey included a question to determine what obstacles had to be overcome with regards to post-treatment permitting. Figure 3-26 shows that twenty percent of the utilities responding to the survey reported that they experienced permitting and regulation issues. Forty percent did not respond to the question and forty percent report that they had not experienced any significant or no permitting issues.

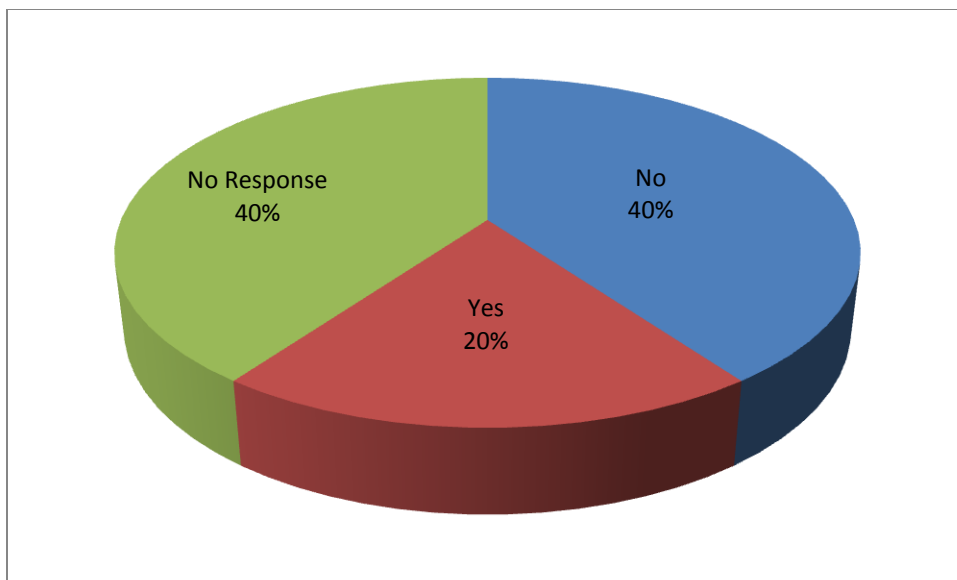

Figure 3-26: With respect to post-treatment (disinfection), what obstacles were overcome to obtain permits/consents?



Specific comments that some of the responding utilities reported included the following issues regarding permitting:

1) A permitting problem due to manganese deposition within the distribution system could be resolved by modifying the operating blend permit and changing operation by simply reducing bypass blend ratios and preferentially pumping the differing qualities of water to minimize manganese impacts

2) There can be problems in negotiating when citing primary disinfection facilities where chlorine gas is to be used, mainly due to newer storage, safety and bulk storage reporting requirements, and

3) There are a number of testing and permitting obstacles at times when permitting post-treatment and residual process streams that require cooperation, understanding, and time to resolve adequately.

Another theme derived from the lessons learned component of the survey included the concept that careful monitoring of process and water quality is essential in the planning of desalination facilities so that potential impacts of the new system being constructed or supplied will support the environment and reduce potential problems with permitting. For example, selection of an adequate location for the site of a desalination plant should be considered using several factors, most outside the scope of this work. However, it is noted that the desalination plant should be planned on a site in such a manner to allow for the successful implementation and operation of the facility over a long period of time. One respondent mentioned that not having a plant located in close proximity to a residential area would be considered a reasonable choice if expansion is planned in the future for the community.

Plants surveyed were asked to give details about the issues experience in the distribution system upon plant startup and how the identified issue was resolved. As shown in Figure 3-27 forty percent of the plants reported having no significant issues; however, twenty-four percent did not respond and thirty percent reported that they had experienced issues related to the following:

- 1) Manganese precipitation and color, which was resolved by modifying plant operation by the addition of a sequestering chemical in addition to reducing, blend ratios.
- 2) Warmer water from deep wells had negative impact on customer acceptance, which was resolved by blending the warmer water with cooler water and in doing so also mitigated issues with taste and odor.
- 3) Failing lead and copper testing at the consumer tap, this was resolved by changing to a different distribution system corrosion control inhibitor.
- 4) Non-defined corrosion issues with premise plumbing, which was resolved with the use of corrosion control chemical.
- 5) Injection well fouling (specifically in one case this occurred when a lime system added excess solids to final product which impacted when sent with concentrate into the injection well). This issue was solved by modifying the lime saturator.

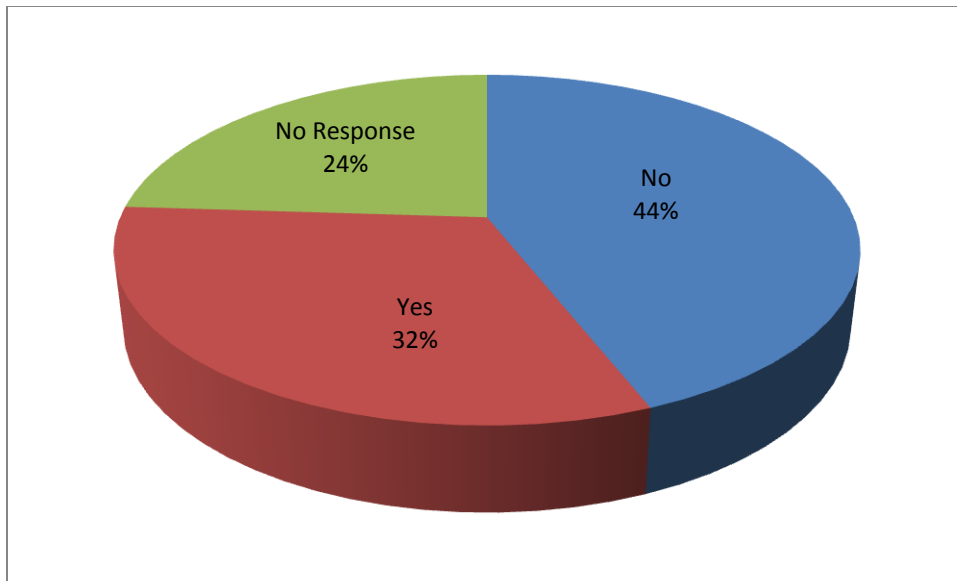

Figure 3-27: Did you experience issues in distribution system after plant startup and if so, what did you do to resolve the problem?

Figure 3-28 indicates that twenty-eight percent of the respondents reported issues with operations related to post-treatment facilities. Thirty-six percent did not respond and another thirty six percent reported not having operational issues. Operational issues that were identified included the following:

- 1) Adequate control of disinfection using chloramines, and
- 2) Red water issues, which were resolved by the addition of CO<sub>2</sub> to increase alkalinity in the distributed finished water. It was noted that proper and effective pretreatment can reduce problems with post-treatment operations specifically related to disinfection and red water mitigation.

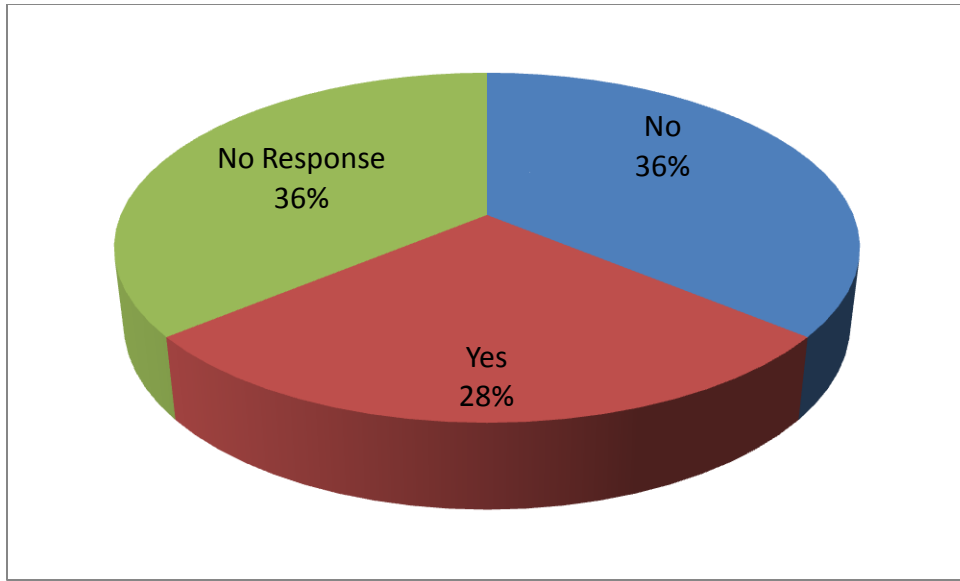

Figure 3-28: Are these issues in the distribution system that has been directly related back to post-treatment?

## CHAPTER FOUR: EXPERT WORKSHOP

### Introduction

An important component of this research project was to conduct a workshop involving the participating utilities. The workshop's objectives were to identify practical experiences with post-treatment stabilization, lessons learned, and identify solutions for utilities experiencing issues with post-treatment. Participants representing utilities from the United States, Caribbean, and Northern Europe attended the expert workshop. Participants had either specific experience with post-treatment of desalinated water or were involved in desalination facilities in the design of post-treatment and operations systems aimed at stabilizing water. To enhance the quality of the workshop, NWRI was tasked with conducting the experts' workshops using the nominal group technique (NGT). NWRI has a track record of success in the development of technical workshops using the NGT, and was selected as a good way to develop, analyze and rank ideas within a group setting. Using the NGT technique as opposed to a committee style setting allowed for consensus within the group to be reached more rapidly and there is an equal opportunity for presentation of ideas.

### Expert Workshop Methodology

#### *Nominal Group Technique*

Originally developed in 1971 as an organizational planning technique, the nominal group technique is a consensus planning tool that helps prioritize issues (Delbecq 1971; Delbecq 1975). Research in group dynamics indicates that more ideas are expressed by individuals working alone but in a group environment than by individuals engaged in a formal group discussion. The NGT is a good way of getting many ideas from a group. It has advantages over the usual committee approach

to identifying ideas. Group consensus can be reached faster and participants have equal opportunity to present their ideas.

In the nominal group technique, participants are brought together for a discussion session led by a moderator. After the topic has been presented to session participants and they have had an opportunity to ask questions or briefly discuss the scope of the topic, they are asked to take a few minutes to think about and write down their responses. The session moderator will then ask each participant to read, and elaborate on, one of their responses. These are noted on a flipchart. Once everyone has given a response, participants will be asked for a second or third response, until all of their answers have been noted on flipcharts sheets posted around the room.

Once duplications are eliminated, each response is assigned a letter or number. Session participants are then asked to choose up to 10 responses that they feel are the most important and rank them according to their relative importance. These rankings are collected from all participants, and aggregated. For example, Table 4.1 provides a simple ranking system for three NGT participants evaluating four responses to a problem.

Table 4-1: Example of Rankings for NGT

<u>Response</u>	<u>Participant 1</u>	<u>Participant 2</u>	<u>Participant 3</u>	<u>of importance</u>
A	ranked 1 <sup>st</sup>	ranked 2 <sup>nd</sup>	ranked 2 <sup>nd</sup>	5 = ranked 1 <sup>st</sup>
B	ranked 3 <sup>rd</sup>	ranked 1 <sup>st</sup>	ranked 3 <sup>rd</sup>	7 = ranked 3 <sup>rd</sup>
C	ranked 2 <sup>nd</sup>	ranked 3 <sup>rd</sup>	ranked 1 <sup>st</sup>	6 = ranked 2 <sup>nd</sup>
D	ranked 4 <sup>th</sup>	ranked 4 <sup>th</sup>	ranked 4 <sup>th</sup>	12 = ranked 4 <sup>th</sup>

Sometimes these results are given back to the participants in order to stimulate further discussion, and perhaps a readjustment in the overall rankings assigned to the various responses. This is done only when group consensus regarding the prioritization of issues is important to the

overall research or planning project. As its name suggests, the nominal group technique is only "nominally" a group, since the rankings are provided on an individual basis. NGT is based on three fundamental, research-based principles:

1. 'Nominal' groups are thought to generate higher quality ideas than interacting groups typical of classic brainstorming. A nominal group consists of several people (usually gathered in one room) who are prepared to work as a team to resolve a problem. This sharing of ideas (which can be anonymously submitted) promotes a sense of involvement and motivation within the group.
2. The 'round robin' element provides encouragement and equal opportunities for all members to contribute. Contribution from all participants is encouraged and every individual's idea is given equal standing, whether unique or not.
3. Reliable communication requires that the recipient's understanding of a message be checked with the sender, especially in the case of 'new ideas' being put forward. Checks for accurate communication are built in to the technique.

Various forms of the procedure can be undertaken, however, the classical form suggested by Delbecq et al. (1975) uses the following steps:

1. Anonymous generation of ideas in writing begins with the facilitator stating the problem and giving the participants up to 10 minutes to jot down any initial ideas privately. The facilitator also writes down his own ideas.
2. Round-robin recording of ideas allows each person in turn to read out one idea, which the facilitator writes up on a flip chart for all to view and numbered sequentially. This is repeated going around the groups until all ideas are exhausted and any duplicates are eliminated.

3. Serial discussion to clarify ideas and check communication is encouraged by the facilitator. Working through each idea systematically asking for questions or comments with a view to developing a shared understanding of an idea. Discussions are calm and controlled to aid clarification of the idea, they are not heated debates.
4. Preliminary anonymous vote on item importance is usually carried out in the method described under anonymous voting.
5. Further discussion and voting, takes place if the voting is not consistent. Steps three to four can be repeated and any ideas that received votes will be re-discussed for clarification.

As with any technique, there are advantages and disadvantages. NGT is no exception. Some of the obvious advantages are that voting is anonymous, there are opportunities for equal participation of group members, and distractions (communication "noise") inherent in other group methods are minimized. As to disadvantages, opinions may not converge in the voting process and the process may appear to be too mechanical.

#### *Location and Purpose*

The workshop was held at UCF's Fairwinds Alumni Center in Orlando, Florida beginning May 21 and ending May 23, 2008. The purpose of the workshop was to identify practical experiences with post-treatment stabilization (i.e. lessons learned) and identify solutions for utilities experiencing problems with post-treatment.



### *Participants*

Attendees of the first workshop included the following persons:

1. John Countz                      Consolidated Water Company, LTD, Cayman Islands
2. Ian Watson                      RosTek Associates, Inc., Tampa, FL
3. Cesar Lopez, Jr.                San Diego County Water Authority, San Diego, CA
4. Albert Ilges                      AwwaRF, Denver, CO
5. Donald Baylor                  City of Pompano Beach, Pompano Beach, FL
6. Christine Owen                Tampa Bay Water, Tampa, FL
7. Gilbert Galjaard                PWN Water Supply Co. North Holland, Netherlands
8. Paul Jurczak                    Town of Jupiter Utilities, Jupiter, FL
9. Steven Duranceau              UCF Civil & Environmental Engineering, Orlando, FL
10. Ferne Rico                      El Paso Public Water Utilities Services, El Paso, TX
11. James Harris                  Naval Facilities Engineering Command, Norfolk, VA
12. Carl Spangenberg              Irvine Ranch Water District, Irvine, CA
13. Sun Liang                        MWD of Southern California, Los Angeles, CA
14. Robert Cheng                  Long Beach Water Department, Long Beach, CA

## Results and Discussion

The workshop efforts resulted in the identification of fourteen priority issues associated with the post-treatment of desalinated permeate. Table 4.2 presents the fourteen identified items with their respective topics and are listed in order of importance, based on NGT ranking procedures.

Table 4-2: Outline of Priority Issues Generated from Workshop

<b>Priority No 1-</b> “Stabilization” Tools for identifying and defining good water quality (consistent water quality) to assure effective water quality results in the distribution system
<b>Priority No 2-</b> Permeate Conditioning / Corrosion Control
<b>Priority No 3-</b> Challenges of disinfection by-product formation – Post-treatment
<b>Priority No 4-</b> Blending Sources to meet Target Water Quality Goals
<b>Priority No 5-</b> Impacts of Blending Permeate into Existing Distribution System
<b>Priority No 6-</b> Secondary Water Quality Impacts to Potable, Wastewater, and Recycled Water
<b>Priority No 7-</b> Informing (rather than educating) consumers, regulators, and political entities of issues related to desalinated water and its post-treatment
<b>Priority No 8-</b> Source Water Characterization as Related to Finished Water Quality
<b>Priority No 9-</b> Permeate Conditioning / Quality & Aesthetics
<b>Priority No 10-</b> Stabilizing a disinfectant residual
<b>Priority No 11-</b> Blending for Finish Water Quality
<b>Priority No 12-</b> Importance of Pilot Studies specifically focused on desalting pre- and post-treatment.
<b>Priority No 13-</b> Recognition of Water Quality Aesthetics Changes as Related to Varying Water Supplies
<b>Priority No 14-</b> Decisions on pretreatment can affect post-treatment decisions/needs.

1. The highest ranked priority was related to how utilities should approach post-treatment stabilization with regards to help and available information. The main idea behind priority one is that stabilization of permeate water is a mandatory component of post-treatment for desalination facilities. Consistency of finished water is an important consideration and the utility must be able to define their “consistent” water, because it may hold different results for different utilities and or locations. Utilities should explore and define consistency goals by evaluating how much variation their systems can withstand without experiencing problems in the distribution system, since there is a range of variability that a distribution system can tolerate when integrating desalinated water into an existing water distribution system. Indicators such as the Langelier Saturation Index (LSI), Ryznar, calcium carbonate precipitation potential (CCPP), aggressiveness index (AI), and dissolved inorganic carbon (DIC) are helpful in predicting the behavior of water within a distribution system. It was recognized by the workshop participants that it is important that facilities implement studies and use available “tools” to understand post-treatment challenges in an effort to develop internal management procedures and technical actions; subsequently, by doing so one could provide consistent and stabilized water quality for the distribution system. Suggested tools include pilot studies, distribution water quality modeling, monitoring, coupon studies, linear polarization, and online water quality instruments within the distribution system.

2. The second highest-ranked priority dealt with permeate conditioning and corrosion control. This topic is interrelated to the highest priority topic identified in the workshop.

Nanofiltration and reverse osmosis permeate are considered corrosive to many types of materials of construction. The permeate produced by synthetic membrane processes can be “aggressive” water that if not stabilized may cause internal damage to many of the components that make up the water distribution system. The utility is required to understand the interrelated issues

between treatment and the distribution system with respect to regulatory compliance, distribution integrity and reliability, and the premise plumbing impacts specifically related to lead and copper release at consumer taps.

3. The third highest priority pertains to the challenges of disinfection by products (DBP) formation during and following post-treatment operations. Considerations must be made with regard to the type of disinfection(s) used and their potential for DBP formation, whether it be chlorinated, chloraminated, brominated, or iodated species. With regards to pretreatment, the use of pH buffers must be taken into account when it comes to their impact on post-treatment. DBP precursors in bypass water must be considered as a contributor to the total DBP concentration in the distribution system, while providing for inactivation of pathogens. Seasonal changes as well as mixing different water sources in the distribution systems should be known. Utilities must be able to meet regulatory standards for disinfection residuals in the distribution system, MCL's of DBP, and lead and copper levels. Potential health risk and issues with blending are imperative to know. For example bromide in permeate is higher than in blend waters and TOC may be higher in blend waters which can affect DBP formation.

4. To meet a target potable water quality goal it may be necessary to blend different water sources and is the topic of priority number four. Water utilities will find themselves unable to meet the future demands with a single source. To meet demands, water purveyors will need to diversify their water resources. These new resources will likely vary in finished water quality. The quantity, quality, and economics of source water will influence the appropriate blend ratios for different waters in different seasons.

5. Priority number five relates to the impacts of blending permeate water into an existing distribution system. Blending of newly desalted water supplies in a system having an older

infrastructure which, historically has been exposed to different supplies of significantly differing quality can cause problems with water quality within the distribution system. Those problems of concern included discolored water, constituents remaining in water such as H<sub>2</sub>S, taste, odor, and corrosion.

6. Secondary water quality impacts to potable, wastewater, and recycled systems were identified as priority six. Issues are many, and some were identified. Since regulatory requirements for potable, wastewater, and recycled water differ, utilities are motivated to understand permit limitations that may be imposed by various regulatory agencies. These limitations may impact the use of desalinated supplies if post-treatment does not address conflicting goals that these other permits may represent. For example, conservative ions will increase through each water cycle which will limit reuse and irrigation use. Post-treatment with sodium hydroxide will add sodium to the water supply but a change to the use of potassium hydroxide would reduce the amount of sodium loading into the environment (i.e. changes in sodium adsorption ratio). Another example is the secondary impact of bromide (other unknown conservative ions such as iodide) entering a blended water supply impacting historical DBP speciation and concentrations (reference priority three).

7. Priority seven topic is *“Informing, rather than educating consumers, regulators and political entities of issues related to desalinated water and its post-treatment.”* Although in the NGT process this item was not ranked as a high priority with regards to post-treatment, priority number seven was seen by the participants to be a significant factor if problems with water quality were to occur. Informing consumers, regulators, and political entities of issues relating to desalinated water and its post-treatment is advised. It is also noted that a utilities understanding of its water treatment process, its cost, and benefits is necessary. Post-treatment is necessary to create a desirable water quality for consumers, to meet regulatory requirements, and protect the distribution system and consumer

infrastructure. Again understanding water quality and impacts of blending different source waters is imperative.

8. Source water characterization as related to the finished water quality was ranked as the eighth priority. Finished water quality can be affected by the source water quality fluctuations, negative impacts may occur that will affect water recycling and irrigation. Boron accumulation through the water cycle was given as an example because its accumulation may negatively impact water recycling and irrigation practices.

9. Priority nine is listed as permeate conditioning, quality, and aesthetics of water quality. NF and RO permeates can contain dissolved gases that may impact the taste and odor acceptability of the water. This is critical for water purveyors in maintaining customer satisfaction and consumer confidence within their drinking water community, within which the utility operates.

10. The tenth-ranked priority considers issues related to stabilizing a disinfectant residual in the distributed water supply. Consideration as to the choice of disinfectants used, types of blending, and regulatory compliance challenges in answering the question “*how to obtain a stable disinfectant residual in the distribution system?*”

11. Priority eleven items were related to blending for finished water quality. Currently blending is a term used to explain a specific unit operation. However, there are several classifications of blending related to the post-treatment of blended streams containing NF / RO permeates. It is important evaluate these by the following general classifications:

1. Blending permeate with other sources in a common blending scheme
2. Bypass blending a component of the raw water into the permeate stream
3. Blending within distribution system at multiple locations having multiple plants
4. Conditioning permeate for transport to remote blending or end use locations

5. Treatment of blending bypass or blending mixtures of multiple source waters

Again, this is important because when adding NF/RO permeate sources into a distribution system destabilizing conditions may occur. To mitigate against possible negative effects proper blending is paramount.

12. Priority twelve notes the importance of pilot studies focused on pre and post-treatment. It may be necessary to continue using pilot plants studies once a facility goes online because it will allow for continued optimization of the process.

13. Recognizing of water quality aesthetics relating to varying supplies is priority thirteen. Water quality changes will occur when water supply changes, which may generate customer complaints. Utility's knowledge of water qualities can deflect negative responses from consumers.

14. Finally, how pretreatment can affect post-treatment decisions and needs is the topic of priority fourteen. Seawater is vastly different across the globe, so basically what works for one utility does not necessarily work for another utility. For example, in the Cayman Islands the deep seawater from Cayman Trench is rich in hydrogen sulfide yet low in dissolved oxygen. Whereas, in the Bahamas, the raw water contains higher levels of dissolved oxygen in water, the water is warmer and contains 2 to 4 mg/L of hydrogen sulfide. These conditions require careful consideration of compatible construction materials. Similar care should be incorporated into selection of post-treatment materials.

### *Guideline for Priority Issues*

Upon determination of the fourteen priority issues recommendations were solicited on how to best handle these issues. The recommended actions that can serve as a guide to desalination facilities in handling the priority issues are listed below:

1. Utilities should consider carrying out pilot studies, distribution system water quality modeling, monitoring, coupon studies, linear polarization, and online water quality instrumentations within the distribution system in order to be able to determine if the desalinated water is to be stabilized and how much stabilization is needed prior to introduction into existing or new distribution systems. Through these studies, the utilities will be able to predict a range of operating conditions for the system, which the distribution network can tolerate, while at the same time ensuring that the quality of water supplied is not compromised.

2. For corrosion control, identification of permeate characteristics is necessary. At the very minimum the pH, temperature, alkalinity, ionic strength, hardness, TOC, sulfates, and chlorides of permeate should be monitored. With these data the susceptibility of the distribution system and the internal plumbing of customer premises can be assessed, and the necessary stabilization program can be instituted to mitigate the problems anticipated.

3. When the choice of disinfection has been made, it is recommended that studies be carried out on the formation of disinfection by products. Alternatively, depending on the water source that is being desalinated, the choice on disinfection can be made after conducting studies and assessing if any disinfection by products may potentially be formed.

4. Looking at the target water quality goals, utilities can assess the various sources of water that is available and determine the type of treatment necessary. Blending of different water sources in order to meet the target water quality is a key consideration. The choice of treatment for the



different sources of waters will need to be evaluated together with the blending ratios. Using mass balance, various source combinations can be evaluated to meet desired finished water quality, in order to optimize the supply, in terms of cost of production and water quality. An example of this is that utilities can blend different supplies for taste and odor control or blend permeate with bypass water at various stages of the process, for control of TDS and chloride.

5. Impacts of permeate in the distribution systems can be resolved by:

- Setting permeate water quality goals;
- Identifying the water quality issues associated with specific source waters and the corresponding permeate water quality;
- Considering and resolving mixing and stability issues before introducing any new sources;
- Considering all treatment options to ensure that all drinking water regulations are met; and
- Developing blending options

6. To resolve the potential issues with secondary water quality impacts i.e. those impact on wastewater and recycled water, it is recommended that utilities understand the comprehensive permit limitations as imposed by regulatory agencies on water, wastewater and water reuse. Knowing the regulatory limits, and the water quality of the available water sources, water quality goals will need to be set that will ensure that all water use, wastewater collection and treatment, and reuse fall within these regulatory limits. The water quality goals will thereafter determine the choice of treatment, blending ratios with multiple sources, quality stabilization and disinfection methods.

7. Customer acceptance is important to the utility and programs need to be introduced to inform stakeholders of the different aspects of desalination and the post-treatment options.

Stakeholders must be informed of the reasons for adopting particular treatment; disinfection and stabilization systems and the benefits that they derive as a result of the utilities taking these measures must also be mentioned.

8. Characterizing source water and its variability in terms of quality and quantity during different seasons is important. Utilities will need to factor this, in considering the treatment, disinfection, and post-treatment stabilization options as part of meeting the water quality goals that it is required to meet.

9) Utilities need to understand the quality of water that it produces and take the necessary measures to condition the water to meet the expectations of customers in terms of quality and aesthetics. It is recommended that odor control and taste acceptability tests be conducted, as these are critical customer acceptance indices.

10. To ensure public health, studies need to be carried out on the choice of post-treatment disinfection process and its stability.

11. When blending water from various sources, with and without treatment, are considered, analysis of blend streams and water quality goals are recommended. Such analysis should also include seasonal fluctuations of various sources, varying operating conditions in the treatment plants, seasonal treated water demand patterns, and any hydraulic limitations within the treatment plant and in the distribution systems.

12. Pilot scale studies are recommended to establish pre and post-treatment systems. It is recommended that considerations be given towards the continued operation of pilot scale studies, even after the commissioning of the treatment facilities. Where large-scale desalination facilities are proposed, demonstration scale studies are recommended, over and above the pilot scale studies. In carrying out the studies, utilities should include the storage and distribution systems including any

new networks if they are proposed, and simulation of the overall production and supply system ought to be also considered.

13. In order to maintain the aesthetics of water that it supplies, the utility should:

- Understand water quality differences from different finished water sources.
- Understand consumers' water quality expectations.
- Evaluate resultant water quality from potential blend changes – and understand how such changes in blending will affect the aesthetics of water. Flavor, taste, and odor tests are recommended, as these are the primary aesthetic parameters of concern to customers. Such evaluation can serve as a predictor of water quality when changes in blending are necessary for various operational reasons.
- Institute an action plan for instances when there need to be changes to the water supply. Such action plans should include effective public communication and outreach strategies.

14. As decisions on pretreatment can affect post-treatment options, pilot studies should focus on optimizing the whole plant to meet the pre-determined treated water quality goals, enabling effective post-treatment.

## CHAPTER FIVE: EVALUATION OF TOTAL IODIDE IN SEAWATER PERMEATE STREAMS

### Introduction

One output of the expert workshop related to disinfection by-products (DBPs), which are formed in the chlorination process. In recent years, an effort has been made to minimize DBPs in finished drinking water. Much of the progress made on this front has been through the identification, treatment, and removal of DBP precursor material. DBPs are commonly formed from the chlorination of drinking water with disinfecting agents such as chlorine, chloramines, ozone, and chlorine dioxide. Regulation controls the prevalence and toxicity of disinfection by-products formed during chlorination. Furthermore, chlorination of a water containing iodides can produce iodinated trihalomethanes and haloacetic acids. However, there is a lack of extensive studies addressing the carcinogenicity of iodated-THMs (Richardson, 2007), but the aesthetic impacts of I-THM's have been documented.

It has been long known that bromides and iodides can be a source of DBPs and are particularly more problematic because they often are more carcinogenic and mutagenic than their chlorinated analogs (Agus et al 2009). Iodide concentrations have been of little concern in the U.S. because common source waters typically have little to no iodide present. However, with the growing demand for water there has been a shift towards brackish and seawater desalination. These source waters, especially seawater, can possess natural total iodide concentrations that could have an impact on disinfection.

During the disinfection process iodide is rapidly oxidized by chlorine to form hypochlorous acid (HOI). The hypochlorous acid is either further reduced to nontoxic iodate or reacts with the organic matter to produce I-THMs (Bichsel and Von Gunten, 1999). The purpose of this evaluation has been to develop a reliable and repeatable method with which to measure and interpret total iodide concentrations in finished drinking water of this origin.

### Approach

Iodide in natural waters have been found to range from less than 1  $\mu\text{g/L}$  in freshwaters to as high as 60  $\mu\text{g/L}$  in some costal surface seawaters (Agus et al. 2009). This range is one of the primary factors in determination of an appropriate method for total iodide concentrations. As these concentrations are attributed to natural untreated water it was hypothesized that once treated by reverse osmosis or nanofiltration it was likely for the iodide concentrations to be in the range of 5-10  $\mu\text{g/L}$ . In order to obtain reading for this relatively low concentration a sensitive method was required. Two methods were deemed appropriate, the “catalytic reduction method” and the “voltammetric method.” These methods are applicable when evaluating samples with iodide concentrations of 80  $\mu\text{g/L}$  or less and 0.13 to 10.2  $\mu\text{g/L}$ , respectively. Ultimately, the catalytic reduction method was selected because of its relative simplicity and repeatability.

The catalytic reduction method is based on the reduction of ceric sulfate by arsenious acid in a sulfuric acid solution. When iodides are present in solution they act as a catalyst for this reduction reaction. As iodide concentrations increase, ceric sulfate reduction also increases. The ceric sulfate solution produced in this method has a distinct yellow color, and as the ceric ions are reduced the yellow colors steadily dissipates. Theoretically, under conditions of constant temperature and reagent concentration the time until disappearance of this yellow color could be used to determine total

iodide concentration. However, a more convenient method has been developed in which the reduction reaction time is held constant and the non-reduced ceric ion concentration are measured. It would be impractical, using this approach, to measure this ion concentration while the reaction is still taking place. To remedy this issue the addition of ferrous ions was implemented in order to arrest the reaction and allow for more consistent and accurate readings.

Ferrous ions arrest the reaction by immediately reducing the remaining ceric ions. The resulting ferric ion concentration is equal to that of the remaining ceric ion concentration present before the reduction reaction is arrested. Addition of a thiocyanide solution then produces a red color of proportional color intensity. The darkness or the red color in this method is inversely proportional to the iodide concentration. (Rogina et.al. 1953). This color intensity can then be measured with respect to a set of standards by means of a color photometer or spectrometer. In order for this method to be accurate and repeatable, several precautions were taken in order to keep the kinetics constant sans changes in the catalyst (total iodide) concentration. They include, 1) control of the temperature variable by use of a water bath set at plus/minus 30°C, 2) stringent control of the time variable from the point of reduction reaction initiation until the addition of the arresting agent, and 3) uniformity and accuracy of reagent concentration/addition to laboratory samples. These variables along with the accuracy of the synthesized iodide standards were found to have the most profound effect on overall accuracy and repeatability.

## Experimental Design

Iodide concentrations were measured using the method dictated by the 20<sup>th</sup> edition of the Standard Methods for examination of Water and Wastewater. The experiment was modified to meet the need for accuracy and precision. Reagents were prepared on a monthly basis (except Ferrous ammonium sulfate, which was prepared daily) per the catalytic method 4500 I- C of the Standard Methods. High-performance liquid chromatography (HPLC) reagent-grade water was used for sample and standard dilutions after problems encountered with distilled water during initial experimentation was identified. A sodium chloride (NaCl) reagent solution was prepared by dissolving 200 grams of NaCl in 1 liter of HPLC reagent-grade water. Formation of non-catalytic forms of iodide such as silver and mercury can have inhibitory effects on iodide readings, so NaCl is used to reduce such effects. Arsenious acid, which is used for the reduction of ceric sulfate in sulfuric acid, was prepared by heating to dissolve 4.946 g of As<sub>2</sub>O<sub>3</sub> and 0.20 mL H<sub>2</sub>SO<sub>4</sub> in 1 liter of HPLC water. Standard 36N sulfuric acid was used for all acid additions. Ceric ammonium was made by dissolving 13.38 grams of Ce(NH<sub>4</sub>)(SO<sub>4</sub>)<sub>4</sub>•4H<sub>2</sub>O with 44 mL of H<sub>2</sub>SO<sub>4</sub> in 1 liter of HPLC water. Ferrous ammonium sulfate reagent was prepared by dissolving 1.50 grams of Fe(NH<sub>4</sub>)<sub>2</sub>(SO<sub>4</sub>)<sub>2</sub> •6 H<sub>2</sub>O in 100 mL of HPLC water with an addition of 0.6 mL of H<sub>2</sub>SO<sub>4</sub> and potassium thiocyanate solution was prepared by dissolved 4.0 grams of KSCN in 100 mL of HPLC water.

For standard iodide solution initial preparations, using the standard method outline did not produce feasible results. In turn, standard iodide solutions were produced using an anion standard iodide with a concentration of 1000 mg/L NaI. Initially a 5000 µg/L standard stock solution was prepared by diluting 0.5 mL of the 1000 mg/L NaI anion iodide standard to 100 mL using HPLC water. Table 5.1 list the standards prepared for the experiment and the volume of the 5000 µg/L

iodide stock solution used in preparation of those standards. The 100  $\mu\text{g/L}$  iodide standard solution was used for preparation of the 0.5, 1.0, 2.5, and 8.0  $\mu\text{g/L}$  standard solutions.

Table 5-1: Standard Solutions Concentrations

Standard Solution	Volume of 5000 $\mu\text{g/L}$ I stock standard used for preparation
0 $\mu\text{g/L}$ I <sup>-</sup>	10 mL HPLC reagent-grade water
0.05 $\mu\text{g/L}$ I <sup>-</sup>	0.05 mL of 100 $\mu\text{g/L}$ I <sup>-</sup> diluted to 100 mL
1.0 $\mu\text{g/L}$ I <sup>-</sup>	1.0 mL of 100 $\mu\text{g/L}$ I <sup>-</sup> diluted to 100 mL
2.5 $\mu\text{g/L}$ I <sup>-</sup>	2.5 mL of 100 $\mu\text{g/L}$ I <sup>-</sup> diluted to 100 mL
5.0 $\mu\text{g/L}$ I <sup>-</sup>	5.0 mL of 100 $\mu\text{g/L}$ I <sup>-</sup> diluted to 100 mL
8.0 $\mu\text{g/L}$ I <sup>-</sup>	8.0 mL of 100 $\mu\text{g/L}$ I <sup>-</sup> diluted to 100 mL
10 $\mu\text{g/L}$ I <sup>-</sup>	0.2 mL of 5000 $\mu\text{g/L}$ I <sup>-</sup> diluted to 100 mL
20 $\mu\text{g/L}$ I <sup>-</sup>	0.4 mL of 5000 $\mu\text{g/L}$ I <sup>-</sup> diluted to 100 mL
40 $\mu\text{g/L}$ I <sup>-</sup>	0.8 mL of 5000 $\mu\text{g/L}$ I <sup>-</sup> diluted to 100 mL
80 $\mu\text{g/L}$ I <sup>-</sup>	1.6 mL of 5000 $\mu\text{g/L}$ I <sup>-</sup> diluted to 100 mL
100 $\mu\text{g/L}$ I <sup>-</sup>	2.0 mL of 5000 $\mu\text{g/L}$ I <sup>-</sup> diluted to 100 mL

Water samples with unknown iodide concentrations were collected from Tampa Bay's reverse osmosis desalination facility utilizing seawater as its source. Tampa Bay's samples included raw, combined permeate, and concentrated water. Long Beach nanofiltration source water was inlet seawater. Long Beach sample water included filtrate and 2<sup>nd</sup> pass permeate from a north and south train used at the facility. Table 5.2 shows the temperature, pH, and conductivity at the time of collection.

Table 5-2: Water Quality Parameters for samples

Sample		Temperature, °C	pH	Conductivity
Tampa Bay Water	Permeate	30	6.5	497
	Filtrate	18.3	7.83	50.91
Long Beach	2nd Pass North	19	10.1	34.5
	2nd Pass South	19	10.5	21.6



For the experiment, approximately 10 mL of each sample, at room temperature, was pipetted into test tubes. Tampa Bay's raw and concentrated water were diluted by using 20 mL of the sample and diluting to 100 mL with HPLC reagent-grade water corresponding to a 1:4 ratio. One duplicate and a 10 µg/L spike were analyzed for quality control and assurance. For the standard solutions 10 mL of each were used to for analysis.

Two people in assembly style performed the experiment. First, 1.00 mL of NaCl, 0.50 mL of arsenious acid, and 0.50 mL of concentrated sulfuric acid, were added to each 10 mL standard solutions and water samples in the respective order. Test tubes-with samples were capped and placed in a water bath at 30.0 degrees Celsius. A test tube containing ceric ammonium sulfate was also placed in the water bath. Samples were allowed to reach temperature equilibrium (approximately 20 to 30 minutes). After 20 minutes with samples remaining in the water bath, caps were removed and 1 mL of ceric ammonium sulfate solution (mix by inverting) was added to each sample in 1-minute intervals. Color upon addition was yellow. Precisely 20 minutes after the introduction of ceric ammonium sulfate to the first sample, the reaction is stopped by the addition of 1.0 mL of ferrous ammonium sulfate. Following a recognizable pattern in 1 minute intervals addition of ferrous ammonia sulfate was added to all the samples, while promptly removing the test tube from bath. Mixing was done by a vortexor. The solutions in the test tube were clear in color. Next 1.00 ml of potassium thiocyanate solution was added to each sample. The KSCN produces a red color that has intensity inversely proportional to iodide concentration.

Samples were allowed to reach ambient room temperate, which took approximately 45 minutes. A spectrophotometer set at 525 nm was used to measure absorbance of the samples using 10 mm cuvette. The spectrometer was calibrated (zeroed) with the blank standard. A standard calibration curve was developed from the standard samples shown in Table 6.1. For each standard

curve developed, there were 7 data points ranging from 0 µg/L to 10 µg/L I<sup>-</sup>. Three data points were used for concentrations ranging from 20 µg/L I<sup>-</sup> to 80 µg/L I<sup>-</sup>. Using the equation developed by non-linear regression using Sigma-plot 11, which followed a 3 parameter exponential decay equation, the concentrations for each sample containing unknown amount of iodide is determined. Figure 5-1 shows the standard calibration curves used for the determination of iodide concentrations in the water samples. It was observed during the development of the standard curves that as the absorbance decreases the concentration of the samples increases, denoting an inverse relationship between the absorbance and concentration. The standard curve data fit equations are presented with the respective R<sup>2</sup> values shown in Table 5-3.

Table 5-3: Standard Curve Equations

Run #	Data Fit Equation	R <sup>2</sup>
1	$y=1.2723+1.2212 * \exp(-0.1077x)$	0.9971
2	$y=1.3369+1.2660 * \exp(-0.1122x)$	0.9949
3	$y=1.4618+1.3147 * \exp(-0.1298x)$	0.9818
4	$y=1.4964+1.4997 * \exp(-0.1206x)$	0.9993
5	$y=1.3201+1.3648 * \exp(-0.1012x)$	0.995
6	$y=1.345+1.3105 * \exp(-0.1142x)$	0.9906
7	$y=1.3664+1.3119 * \exp(-0.1348x)$	0.9774
8	$y=1.4264+1.4516 * \exp(-0.1142x)$	0.9990
9	$y=1.3534+1.3618 * \exp(-0.1152x)$	0.9992
10	$y=1.4279+1.3965 * \exp(-0.1187x)$	0.9982
11	$y=1.5859+1.5137 * \exp(-0.1228x)$	0.9966

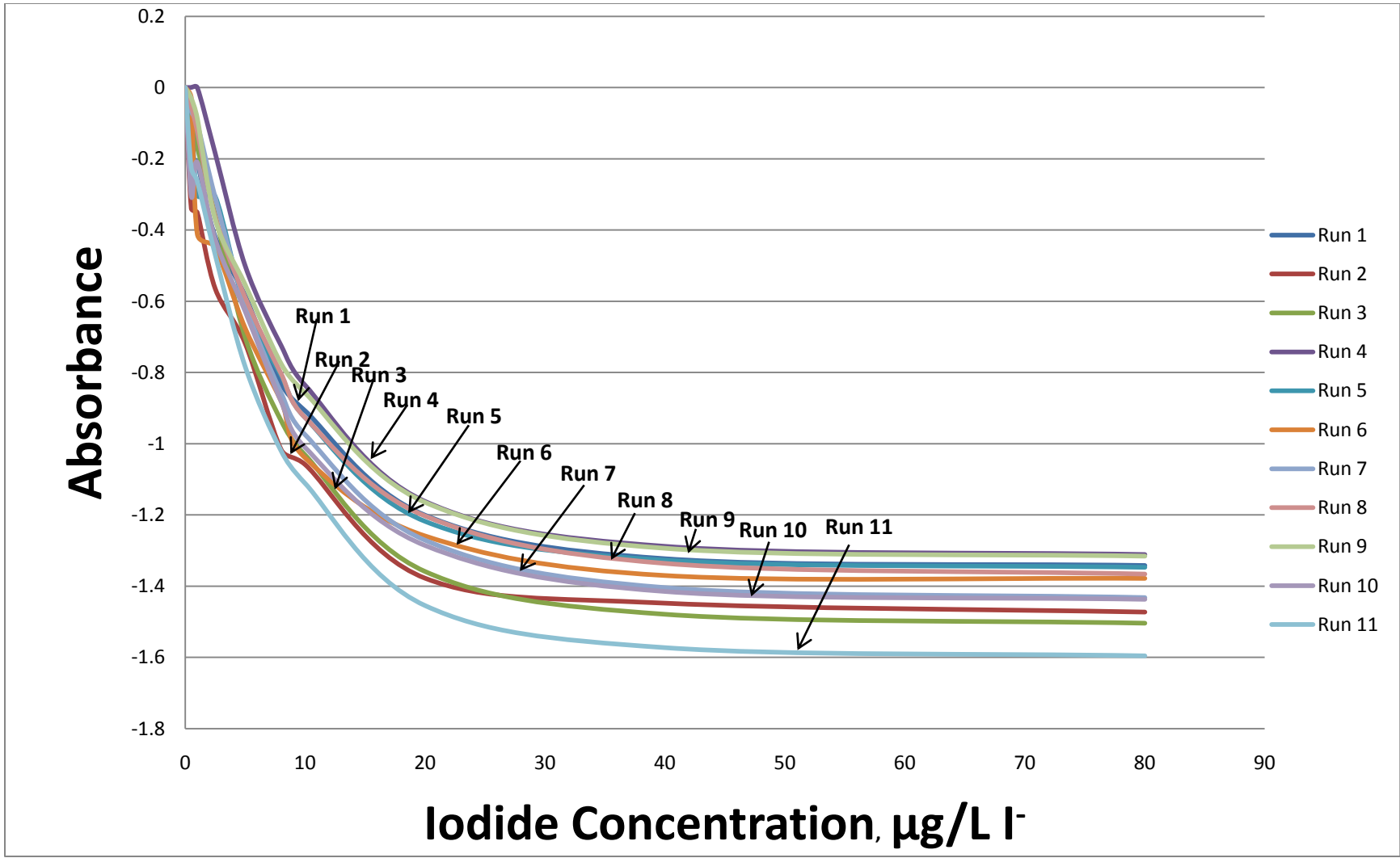

Figure 5-1: Iodide Calibration Curves

Results and Discussion

Table 5.3 below shows concentration values found for Tampa and Long Beach waters. Concentration of iodide in Tampa Bay’s RO process raw feed water was found to on average 36.06 µg/L I<sup>-</sup>, which is in the typically range found for seawater process. Permeate iodide concentration were found to be an average of 10.30 µg/L I<sup>-</sup> Concentrate values were on average 70.12 µg/L I<sup>-</sup> Iodide concentrations were below the detection limit of 8 µg/L I<sup>-</sup>. The average iodide concentrations were plotted and shown in Figure 5.2 and error bars shows the maximum and minimum observations.

Table 5-4: Iodide Concentrations for Tampa Bay RO Water

<b>Samples</b>	<b>Concentration, µg/L I<sup>-</sup></b>
Tampa Bay Raw Water	41.31
	42.31
	31.25
	32.23
	33.20
Mean	36.06
Std	5.31
Std Error	2.37
Tampa Bay Permeate	6.38
	9.57
	9.74
	15.5
	10.3
Mean	10.3
Std	3.8
Std Error	1.9
Tampa Bay Concentrate	69.25
	70.59
	53.19
	69.70
	87.87
Mean	70.12
Std	12.28
Std Error	5.49

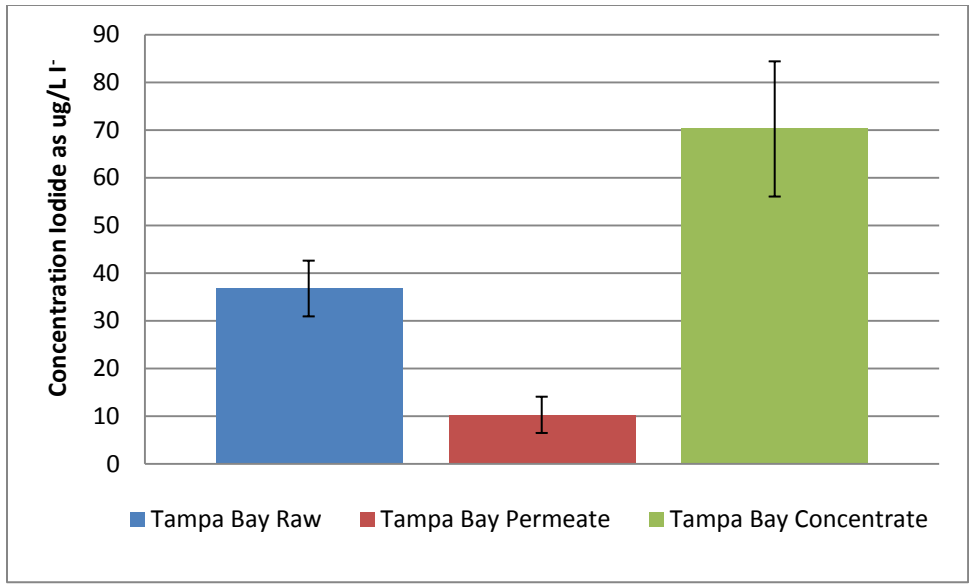

Figure 5-2: Tampa Bay Mean Iodide Concentrations with Max and Min Observations

Shown on Table 6.4 filtrate water for the Long Beach NF process was found to have an average iodide concentration of 43.73  $\mu\text{g/L I}^-$ . The Long Beach facility had two permeate streams that produce different results for iodide concentrations. The Long Beach NF 2<sup>nd</sup> pass north iodide concentrations on average 0.24  $\mu\text{g/L I}^-$ , well below our hypothesized detection limits. The 2<sup>nd</sup> pass iodide concentration was average to be 11.41  $\mu\text{g/L I}^-$ . The average iodide concentrations were plotted and shown in Figure 6.3 and error bars show the maximum and minimum observations.

Table 5-5: Iodide Concentrations for Long Beach NF Water

Samples	Concentration, $\mu\text{g/L I}^-$
Long Beach Filtrate	45.33
	42.78
	49.27
	41.52
	42.47
	41.04
Mean	43.73
Std	3.10
Std Error	1.27
Long Beach 2nd Pass North	0.11
	0.14
	0.21
	0.41
	0.35
	0.24
Mean	0.24
Std	0.13
Std Error	0.06
Long Beach 2nd Pass South	8.25
	8.76
	8.71
	15.06
	16.25
	11.41
Mean	11.41
Std	3.91
Std Error	1.75

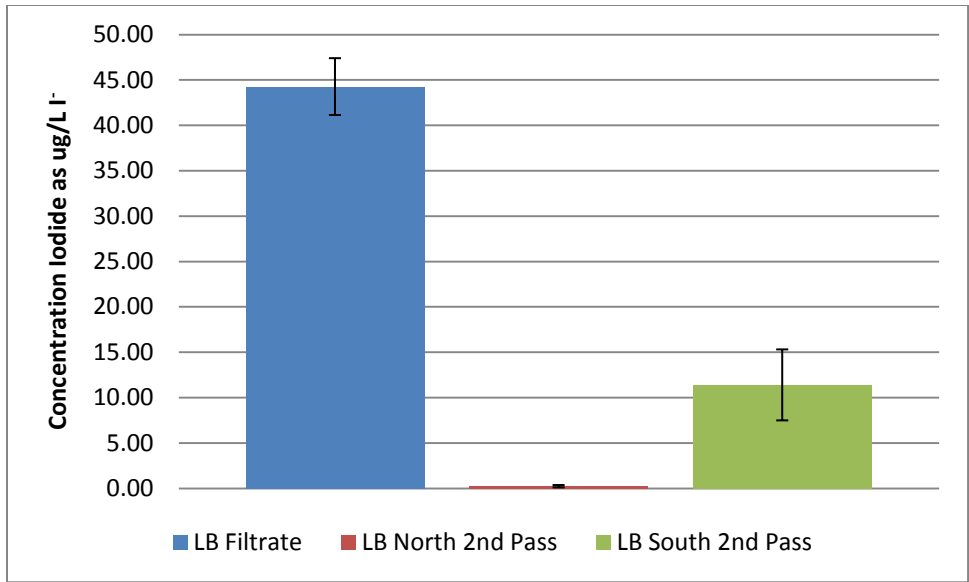

Figure 5-3: Long Beach Mean Iodide Concentrations with Max and Min Observation

*Quality Assurance and Quality Control*

For quality assurance and quality control a minimum of one duplicate and spike samples were performed for every ten samples were performed. Duplicates were analyzed to determine any variance with samples and to check the reproducibility of the method. Spikes of 10 µg/L I using the 100 µg/L I standard were performed to determine the percent recovery (ratio of product feed to water produce) of the method. Table 5-6 shows the 95% confidence interval, percent recovery, relative percent difference (RPD), upper control limit (UCL), and upper warning limit (UWL) for the samples. Percent recovery for the Tampa Bay samples was found to be 95.70 %, compared to the Long Beach sample which was 74.90 %. The typical range required percent recovery on is 70% to 120%. The Tampa Bay samples are in the median range for permeate production, compared to Long Beach samples where were found to be at the lower end of the recovered percentage. The reproducibility (RPD) of Tampa Bay’s; raw water was determined to by 2.39% while concentrated had a RPD of 1.92%. Long Beach RPD was determined to be 2.28%. Typically it is best to have

RPD with the range of 1% to 10%, where been at the lower end of that range is optimum. The RPD values for the samples indicate the method used for determining iodide concentrations is accurate.

Table 5-6: Quality Assurance and Control Parameters

<b>Sample</b>	<b>Confidence Interval</b>	<b>Percent Recovery %</b>	<b>RPD %</b>	<b>UCL</b>	<b>UWL</b>
Tampa Bay Water					
Raw	±4.65	—	2.39	51.99	46.68
Permeate	± 3.72	95.7	—	21.7	17.9
Concentrate	± 10.76	—	1.92	106.96	94.68
Long Beach Water					
Filtrate	± 2.48	—	2.28	53.03	49.93
North: 2nd					
Pass	± 0.114	—	—	0.63	0.64
South: 2nd					
Pass	± 3.43	74.9	—	23.14	19.22

From the results of the analysis it is shown that by using the catalytic reduction method concentrations of iodide were detected in feed, permeate, and concentrated water. Seawater being treated by a desalination process results in a significant reduction in iodide concentrations to levels near or below analytical detection limits; consequently, trace amounts of iodide would be expected to not significantly impact the formation of iodinated disinfection by-products.



## CHAPTER SIX: CONCLUSION AND RECOMMENDATIONS

### Summary

With a growing number of potable water purveyors turning to desalination processes as a means for augmenting existing drinking water supplies, it is important to understand the behavior of desalted permeate within the distribution system and possible issues that may arise if proper post-treatment of permeate is not practiced. Desalination water is considered corrosive due to its inherently low mineral content and is not suitable for consumption without post-treatment. A review of relevant literature indicates that post-treatment is required for desalted permeate, and would include consideration of possible impacts from blending, remineralization, disinfection, storage and distribution.

Based on the information obtained from the literature review, a utility questionnaire was developed and distributed to utilities known to rely on desalination processes and located in the U.S., Caribbean, and Europe to gather information on post-treatment. Water quality data was obtained from each facility, in addition to delineation of post-treatment practices and identification of impacts experienced to the distribution system. Questions were also asked regarding plant descriptions, operation costs, and a summary of post-treatment actual experiences.

A workshop was conducted that brought together experts in the field of desalination where they could describe their experiences with post-treatment stabilization, share lessons they have learned, and offer guidance to utilities experiencing problems with post-treatment. The experts identified fourteen priority guidance recommendations to deal with the many issues associated with post-treatment, as were presented in Table 4.2. found in chapter 4.

One of the issues identified in the workshop was related to disinfection of permeate and resultant disinfection-by-products (DBPs). As illustrated in the literature review, bromide is known to permeate the membrane and will serve as a brominated-DBP precursor when the permeate is blended with a native water supply conventionally treated. Recently it has been shown that iodinated DBPs can be present in treated water supplies where iodide levels are naturally occurring. Although the amount of iodide permeating a membrane is not fully known, it is known that iodinated DBPs can form in a manner analogous to bromide in drinking water. Consequently, two of the participant utilities (Tampa Bay Water and City of Long Beach) submitted permeate water samples taken from the permeate of their desalination facilities for analytical determination of iodide using a catalytic reduction method for detection.

#### *Literature Review Findings*

Stabilizing permeate water is accomplished by effectively controlling aspects of post-treatment. Most of the literature pointed to the use of various chemical treatments to achieve post-treatment goals. Literature indicates that there are several considerations that should be taken into account when deciding post-treatment strategies, including the quality of the chemicals added, controlling dosage rates, and minimizing unwanted chemical reactions within the distribution system. It was found that primary post-treatment unit operations includes degasification (decarbonation) for CO<sub>2</sub> removal, air stripping for H<sub>2</sub>S removal, alkalinity and pH adjustment for stabilization, corrosion control, and disinfection. Post-treatment unit operation performance is dependent on the source water type and the desalination process. Stabilization of finished water typically includes the addition of carbonate alkalinity, the use of corrosion inhibitors, remineralization through blending with source water, disinfection, and enhanced removal of specific compounds.

Due to low mineral content of desalted water, blending with source water allows for the addition of mineral such as sodium, calcium, potassium, and magnesium. When seawater is used for blending, the ability to by-pass source water and blend permeate for stability is limited to one percent, and hence is not typically practiced. In addition, it has been reported that blending could be problematic if bromides are present because of the possible formation of regulated and non-regulated DBPs, and possible impacts of bromide on chloramines disinfection. Some literature suggested that poor buffering might lead to stability problems such that corrosion control is needed, and could be accomplished with alkalinity and pH adjustment or the use of inhibitors

Effective disinfection of desalted water is accomplished by the use of sodium hypochlorite, chlorine gas, chloramines, and ozone. It is important to note that disinfection-by-product formation of blended finished water supplies could be greater when blending native source waters containing TOC with seawater permeate due to higher concentration of bromide in the permeate. Recently iodinated DBPs have gained more attention as evidence suggests their presence in many water supplies across the US; however, the relative contribution of seawater permeate to iodinated DBP formation due to the passage of iodide across the membrane remains in question. Stabilization and disinfection are required components of post-treatment processes. Developing treatment goals to define post-treatment design targets is recommended by many in the literature.

### Conclusions

#### *Questionnaire Findings*

Compilation and analysis of the questionnaire results indicated that there are a variety of methods currently relied upon that could be used for post-treatment of permeate. A majority of the surveyed facilities reported the use of degasification, air stripping, chemical addition of caustic soda (sodium hydroxide) for pH adjustment, with or without the need for by-pass or native source water blending. In some instances, more than one form of post-treatment was implemented. Treated

ground and surface water were reported to be used to accomplish blending for some facilities. Specific details on blending were provided by some facilities who reported blending with ion exchange treated source water, by-passed raw groundwater, and lime-softened or calcite filtered ground water.. Of the facilities that reported degasification and blending for post-treatment, few reported blending issues or biological growth within degasification units. Primary disinfection is accomplished mainly by chlorine addition, although a number of facilities reported using chloramines for primary treatment.

Chloramines was the main chemical used for secondary disinfection to carry residual into the system. Chlorine residual goals reported by the surveyed facilities ranged from 2-5 mg/L at the point of entry (i.e. leaving the plant), and 1 mg/L within the distribution system. Facilities reporting the use of chloramines indicated that residual goals of 4 mg/L leaving the plant is desired and was between 1 mg/L and 2.5 mg/L within the distribution system.

Many facilities reported taking advantage of, blending and by-pass options for post-treatment stabilization purposes; however, specific methods or types of sources use widely varied between utilities. Blending options included: 1) blending permeate with raw by pass water, 2) blending using water from lime softening, RO and NF processes, 3) blending with brackish water or water produced by ion exchange. Facilities that were reliant upon using by-pass reported bypass blending ratios between ten and thirty percent. It was also reported that blend water alkalinity averaged about 150 mg/L as CaCO<sub>3</sub>, as compared to post-treatment using alkalinity adjustment, which averaged approximately 62 mg/L as CaCO<sub>3</sub> at the POE. In addition, the average pH was 8.2 at the POE, along with an average daily permeate flow ranging from 0.15 MGD to 70 MGD and an average blending flow rate ranging from 2 to 10.5 MGD.

One comment that was consistently provided by the reporting utilities that had experienced distribution system related problems when using permeate as part or all of their water portfolio was

that pilot testing of the membrane process in concert with the post-treatment would be useful in identifying possible issues and aid to limit adverse impacts. Pilot testing can help determine issues related to such items as stabilization, degasification, disinfection, corrosion control, and blending concerns. Most facilities did not incorporate pilot post-treatment testing, yet did acknowledge they performed pilot testing for the membrane process. A combined or comprehensive approach to permeate post-treatment design evaluations was seen to be beneficial because the proper design of the post-treatment processes will reduce impacts within the facility, particularly blending practices.

#### *Expert Workshop Proves Beneficial Findings*

The expert workshop was a positive and well-executed activity where fourteen priority issues were identified. The highest ranked priority was related to how utilities should approach post-treatment stabilization with regards to help and available information. The main idea behind this highest priority is that stabilization of permeate water is a mandatory component of post-treatment for desalination facilities. Utilities should explore and define consistency goals by evaluating how much variation their systems can withstand without experiencing problems in the distribution system, since there is a range of variability that a distribution system can tolerate when integrating desalinated water into an existing water distribution system.

The second highest-ranked priority dealt with permeate conditioning and corrosion control. This topic is interrelated to the highest priority topic identified in the workshop. Nanofiltration and reverse osmosis permeate are considered corrosive to many types of materials of construction. Permeate produced by synthetic membrane processes can be “aggressive” water that if not stabilized may cause internal damage to many of the components that make up the water distribution system. The utility is required to understand the interrelated issues between treatment and the distribution

system with respect to regulatory compliance, distribution integrity, and reliability, and the premise plumbing impacts specifically related to lead and copper release at consumer taps.

The third highest priority pertains to the challenges of disinfection by products formation during and following post-treatment operations. Considerations must be made with regard to the type of disinfection(s) used and their potential for DBP formation, whether it be chlorinated, chloraminated, brominated, or iodinated species. With regards to pretreatment, the use of pH buffers must be taken into account when it comes to their impact on post-treatment. DBP precursors in bypass water must be considered as a contributor to the total DBP concentration in the distribution system, while providing for inactivation of pathogens. Seasonal changes as well as mixing different water sources in the distribution systems should be identified.

Other priorities were related to defining water quality goals that are assessed based on source water type. Since blending is commonly used to improve stability of permeate water, caution was offered by the workshop participants based on their experiences because there can be secondary impacts of blending in the distribution system with regards to consumer confidence and water quality; hence, planning and testing should be taken into consideration when blending.

Additional priorities were related to classification of the source of blending to achieve finished water quality goals. Consumer acceptance is imperative, so educating the public on the regulations related to desalinated water and post-treatment is necessary. Pretreatment can affect post-treatment decisions and careful selection on unit processes and chemical addition should be considered prior to use.

#### *Iodide Was Found to Be Present In Permeate*

Iodide concentrations were detected for raw and permeate samples produced by Tampa Bay's seawater desalination plant, as well as at the City of Long Beach's nanofiltration desalination

plant. Iodide was detected using a catalytic reduction procedure that proved to be effective for measuring iodide offering a method detection limit of 8 µg/L as iodide (I).

It was determined that the Tampa Bay Water desalted permeate iodide concentration was on average 10.3 µg/L I, and represented a combined overall permeate concentration value. Testing was limited to combined permeate as interpass samples could not be collected as a result of utility constraints. However, the Long Beach facility consisted of two redundant membrane trains configured in a two-pass flow, of which the second pass locations were sampled for this study. Average iodide concentrations were determined to be 0.24 µg/L (as I) and 11.4 µg/L (as I) for the 2<sup>nd</sup> pass North process train and 2<sup>nd</sup> pass South train, respectively. The difference in iodide concentration between process trains is due to differences with the membranes used for in each process train.

Regarding quality control efforts, it was determined that Tampa Bay iodide analyses had a 95.7% spike recovery. For Long beach samples, a 74.9 % recovery was determined. Although testing for iodide was limited to two seawater facilities, and although the iodide levels detected in the permeate of these two seawater facilities was low, the data presented herein is the first known data to be available with respect to understanding iodide quantities in municipal seawater permeate.

### Recommendations

Based on the results of this study, stabilization and effective disinfection of permeate water is the most important aspect of post-treatment design and operation. It is recommended that water purveyors carefully assess the integration of desalination into their water portfolio, and in doing so, develop practical and reasonable post-treatment goals in addition to the goals typically developed for the desalination process itself.

Furthermore, pilot plant testing that takes into account post-treatment processes is important to develop proper design to achieve overall drinking water goals for the distribution system. Most water purveyors understand the need to focus on pilot testing for the membrane process, however, as a result of this study that included an expert workshop, pilot testing should extend to include post-treatment processes that are to be implemented for the specific need. This could include such unit operations as degasification, air stripping, pH adjustment or chemical conditioning with bases or inhibitors, and must at a minimum require disinfection evaluations. Considerations for effective post-treatment should also include an understanding of feed water sources, address the potential of by-pass or native water blending for stabilizing permeate, the effect of alternative disinfectants when used (such as chloramines), and a realization to include programs to enhance and evaluate consumer confidence in these efforts.

It is recommended that an investigation be conducted to further test for iodide in the permeate of brackish water facilities, as this work focused on the only two operating seawater facilities in the US. Since there are several hundred brackish water facilities in operation, this effort would appear reasonably easy to implement. Furthermore, an investigation regarding the impact on iodide in desalted seawater permeate on the formation of iodinated-DBPs should be conducted on blends of a variety of native water supplies and this seawater permeate. It is not known what would be the impact of blending differing native or traditional water supplies with desalted seawater permeate.





## **APPENDIX A: POST TREATMENT QUESTIONNAIRE**

**AWWARF PROJECT 4079**  
**Post Treatment Stabilization of Desalinated Water**  
**Post Treatment Questionnaire**

1. For questions that may require more space than is provided, please use a separate sheet of paper.
2. Handwritten responses are preferred to avoid transcription errors during typing.
3. Write NIA if no information is available.
4. Please return the completed questionnaire to:

Steven J. Duranceau, PhD, PE  
Civil and Environmental Engineering  
UNIVERSITY OF CENTRAL FLORIDA  
P.O. Box 162450  
Orlando, FL 32816-2450

Should you have any questions regarding this questionnaire, please contact Steven Duranceau at (407) 823-1440 or by e-mail at [sdurance@mail.ucf.edu](mailto:sdurance@mail.ucf.edu)

**I. BACKGROUND INFORMATION**

Name and Address of the Membrane Plant:

1. Plant Name: \_\_\_\_\_
2. Plant Address: \_\_\_\_\_  
\_\_\_\_\_  
\_\_\_\_\_

3. Plant Type:

a. Categorize by the TDS of Feed:

- \_\_\_\_\_ Seawater [SW]: (20,000 – 35,000 mg/L TDS)  
\_\_\_\_\_ High Brackish Groundwater [GW]: (>7,500 - <20,000 mg/L TDS)  
\_\_\_\_\_ High Brackish Surface Water [SFW]: (>7,500 - <15,000 mg/L TDS)  
\_\_\_\_\_ Low Brackish GW: (1,000 – 5,000 mg/L TDS)  
\_\_\_\_\_ Low Brackish SFW: (1,000 – 2,500 mg/L TDS)  
\_\_\_\_\_ Fresh GW: (<1,000 mg/L)  
\_\_\_\_\_ Fresh SFW: (<1,000 mg/L)  
\_\_\_\_\_ Others (please explain) \_\_\_\_\_

b. Is it GWUI (Groundwater under the influence of surface water)? \_\_\_\_\_

Post Treatment Stabilization of Desalinated Water  
Post Treatment Questionnaire

Plant Name: \_\_\_\_\_

4. Contact Person and Telephone Number:

Name: \_\_\_\_\_

Telephone Number: \_\_\_\_\_

Email Address: \_\_\_\_\_

5. Web Site Address: \_\_\_\_\_

6. Name of Owner: \_\_\_\_\_

Address of Owner: \_\_\_\_\_

7. Public or Private Ownership:

\_\_\_\_\_ Public Agency (Municipality)

\_\_\_\_\_ Water Authority

\_\_\_\_\_ Private Agency

\_\_\_\_\_ Others (please describe) \_\_\_\_\_

8. Water Quality Driver (Check all that apply):

\_\_\_\_\_ Arsenic

\_\_\_\_\_ Salt Removal

\_\_\_\_\_ Hardness Removal

\_\_\_\_\_ TOC Removal

\_\_\_\_\_ Color Removal

\_\_\_\_\_ Radionuclide Removal

\_\_\_\_\_ SOC Removal

\_\_\_\_\_ Specific Contaminant  
(please specify) \_\_\_\_\_

\_\_\_\_\_ Others (please specify) \_\_\_\_\_

Post Treatment Stabilization of Desalinated Water  
Post Treatment Questionnaire

Plant Name: \_\_\_\_\_

**II. RO/NF MEMBRANE PLANT DESIGN CHARACTERISTICS**

**a. General Design Data**

1. Plant Production Startup Date: \_\_\_\_\_ (mm/yyyy)
2. Design Hydraulic Capacity of Plant: \_\_\_\_\_ mgd or \_\_\_\_\_ million L/day
3. Plant Originally Designed for Expansion: \_\_\_\_\_ yes \_\_\_\_\_ no
4. Design Percent RO Feedwater Recovery: \_\_\_\_\_ percent (%)
5. Design RO Membrane Flux: \_\_\_\_\_ gal/day-ft<sup>2</sup> \_\_\_\_\_ L/hr-m<sup>2</sup>
6. Design Pressure: \_\_\_\_\_ psi (max) \_\_\_\_\_ bar (max)  
\_\_\_\_\_ psi (min) \_\_\_\_\_ bar (min)

7. What is the end use of the RO/NF permeate? (Check all that apply)

- \_\_\_\_\_ Potable Water
- \_\_\_\_\_ Industrial Use
- \_\_\_\_\_ Groundwater Recharge (for indirect potable reuse)
- \_\_\_\_\_ Groundwater Recharge (seawater intrusion barrier)
- \_\_\_\_\_ Irrigation
- \_\_\_\_\_ Others (please specify) \_\_\_\_\_

**b. Plant Schematic**

Please attach an overall schematic of the plant showing any pre- and post-treatment processes to membrane filtration, including location chemical addition. Acceptable file formats: GIF, JPG, PDF, MS Powerpoint, MS Word, MS Excel. Note that hardcopies, including handwritten hardcopies are acceptable and can be sent via regular mail.

Post Treatment Stabilization of Desalinated Water  
Post Treatment Questionnaire

Plant Name: \_\_\_\_\_

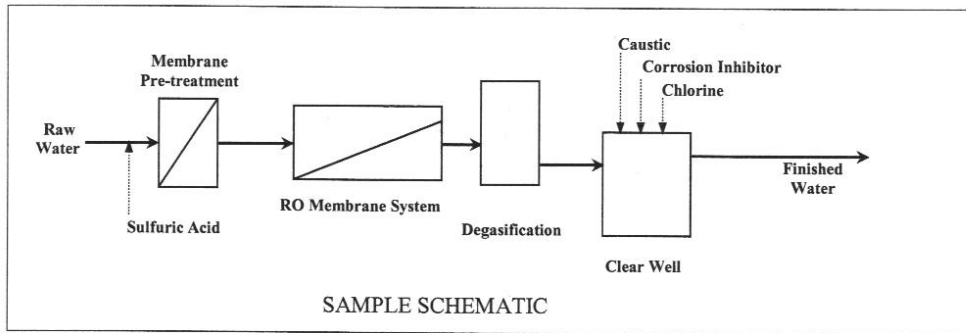

c. Source Water

- \_\_\_\_\_ Ocean Intake
- \_\_\_\_\_ Ocean Well
- \_\_\_\_\_ Brackish Water Well
- \_\_\_\_\_ Fresh Ground Water Well
- \_\_\_\_\_ Gulf/Bay
- \_\_\_\_\_ Lake/Reservoir
- \_\_\_\_\_ Flowing Stream/River
- \_\_\_\_\_ Agricultural Drainage
- \_\_\_\_\_ Other (please specify) \_\_\_\_\_

Post Treatment Stabilization of Desalinated Water  
Post Treatment Questionnaire

Plant Name: \_\_\_\_\_

**III. POST TREATMENT INFORMATION**

**a. Post Treatment Information**

1. Post treatment type: (Check all that apply)

- \_\_\_\_\_ Air stripping/desulfurization
- \_\_\_\_\_ Degasification/decarbonation
- \_\_\_\_\_ Caustic chemical addition
- \_\_\_\_\_ Corrosion inhibitor addition
- \_\_\_\_\_ Blending
- \_\_\_\_\_ Treated surface water
- \_\_\_\_\_ Treated groundwater
- \_\_\_\_\_ Other (please specify) \_\_\_\_\_

2. Disinfection:

- Primary \_\_\_\_\_ Chlorine \_\_\_\_\_
- \_\_\_\_\_ Ozone \_\_\_\_\_
- \_\_\_\_\_ UV \_\_\_\_\_
- \_\_\_\_\_ Chlorine dioxide \_\_\_\_\_
- \_\_\_\_\_ Other (please specify) \_\_\_\_\_
- Secondary \_\_\_\_\_ Chlorine \_\_\_\_\_
- \_\_\_\_\_ Chloramine \_\_\_\_\_
- \_\_\_\_\_ Other (please specify) \_\_\_\_\_

3. Not taking into account the membrane process, what are your post-treatment disinfection and disinfectant residual goals?

\_\_\_\_\_  
\_\_\_\_\_

Post Treatment Stabilization of Desalinated Water  
Post Treatment Questionnaire

Plant Name: \_\_\_\_\_

4. Have you experienced any post treatment problems within the plant? (Check all that apply)

- \_\_\_\_\_ Blending limitation like salt concentration or DBP precursors
- \_\_\_\_\_ Scaling of degasification/stripping towers
- \_\_\_\_\_ Biogrowth in degasification/stripping towers
- \_\_\_\_\_ Chemical injector plugging
- \_\_\_\_\_ Specific issues with cleaning post treatment equipment
- \_\_\_\_\_ White water formation
- \_\_\_\_\_ Corrosion events
- \_\_\_\_\_ Colored or red water
- \_\_\_\_\_ Others (please specify) \_\_\_\_\_

5. Any distribution system impacts noted? (Check all that apply)

- \_\_\_\_\_ Corrosion events (infrastructure)
- \_\_\_\_\_ Lead and Copper Rule impacts
- \_\_\_\_\_ Disinfection By-Products
- \_\_\_\_\_ Taste and odor
- \_\_\_\_\_ Detention time prior to point of entry to distribution system
- \_\_\_\_\_ Detention time after point of entry to distribution system
- \_\_\_\_\_ pH stability
- \_\_\_\_\_ Disinfection residual stability
- \_\_\_\_\_ White water
- \_\_\_\_\_ Color
- \_\_\_\_\_ Red water/black water
- \_\_\_\_\_ Biological regrowth
- \_\_\_\_\_ Others (please specify) \_\_\_\_\_



Post Treatment Stabilization of Desalinated Water  
Post Treatment Questionnaire

Plant Name: \_\_\_\_\_

6. Provide blended or by-pass description (if applicable):

\_\_\_\_\_  
\_\_\_\_\_  
\_\_\_\_\_

7. Are blending tanks/structures used? \_\_\_\_\_

8. What is your sequence of post treatment operations?

\_\_\_\_\_  
\_\_\_\_\_  
\_\_\_\_\_

9. How do you control the pH and buffering content of the post treated RO water prior to release into the system?

\_\_\_\_\_  
\_\_\_\_\_  
\_\_\_\_\_

10. Describe your method of corrosion control. (Check all that apply)

- \_\_\_\_\_ pH Adjustment
- \_\_\_\_\_ Alkalinity adjustment
- \_\_\_\_\_ Hardness adjustment
- \_\_\_\_\_ Corrosion inhibitor, type: \_\_\_\_\_
- \_\_\_\_\_ Blending
- \_\_\_\_\_ Others (please describe) \_\_\_\_\_

Post Treatment Stabilization of Desalinated Water  
Post Treatment Questionnaire

Plant Name:

Water Quality Data (continued)									
Parameters	RO Permeate			Blend Water (if used)			Point of Entry to Distribution System (POE)		
	Low	High	Avg	Low	High	Avg	Low	High	Avg
Sodium, mg/L									
Potassium, mg/L									
Barium, mg/L									
Calcium, mg/L									
Magnesium, mg/L									
Strontium, mg/L									
Iron, mg/L									
Manganese, mg/L									
Silica, mg/L									
Sulfate, mg/L									
Chloride, mg/L									
Bromide, mg/L									
Phosphate, mg/L as PO <sub>4</sub>									

Post Treatment Stabilization of Desalinated Water  
Post Treatment Questionnaire

Plant Name: \_\_\_\_\_

Water Quality Data (continued)									
Parameters	RO Permeate			Blend Water (if used)			Point of Entry to Distribution System (POE)		
	Low	High	Avg	Low	High	Avg	Low	High	Avg
Aluminum, mg/L									
Fluoride, mg/L									
Hydrogen Sulfide, mg/L									
Selenium, mg/L									
<b>Microbiological Quality</b>									
Total Coliform bacteria, #/100 mL									
Algal Counts, #/mL									
Heterotrophic plate count bacteria, cfu/mL									
<i>Pseudomonas</i> , #/100 mL									
<b>Stability Index</b>									
LSI									
Ryznar									

Post Treatment Stabilization of Desalinated Water  
Post Treatment Questionnaire

Plant Name: \_\_\_\_\_

**IV. POST TREATMENT WATER QUALITY**

Please complete the following table. Enter the low, high, and average values, if known. If not, the average value is required. If data is not available for any particular parameter, enter "NA". If an analytical result was below detection limit, enter "BDL".

Water Quality Data									
Parameters	RO Permeate			Blend Water (if used)			Point of Entry to Distribution System (POE)		
	Low	High	Avg	Low	High	Avg	Low	High	Avg
Temperature, °C									
pH [R]									
Alkalinity, mg/L as CaCO <sub>3</sub>									
Turbidity, NTU									
Conductivity, umho/cm									
Total Dissolved Solids, mg/L									
Total Organic Carbon, mg/L									
Color, CPU									
Total Suspended Solids, mg/L									

Post Treatment Stabilization of Desalinated Water  
Post Treatment Questionnaire

Plant Name: \_\_\_\_\_

**V. POST TREATMENT OPERATION**

1. Daily NF/RO permeate production: 

Average	Maximum (if available)

 mgd

2. Flow, mgd

	Low	High	Average
Permeate			
Blend			

3. Post treatment chemicals (include residual disinfectant, pH adjustment, corrosion inhibitor chemicals):

Chemicals	Average dose rates

4. Blend ratio, as a percentage (%) of total flow to plant. \_\_\_\_\_

5. Control of blending operation:  
Provide a brief description on how the plant controls post treatment operations.

\_\_\_\_\_

\_\_\_\_\_

\_\_\_\_\_

\_\_\_\_\_

Post Treatment Stabilization of Desalinated Water  
Post Treatment Questionnaire

Plant Name: \_\_\_\_\_

**VI. POST TREATMENT O&M COSTS**

**O&M in \$/1000 gal**

1. Overall operating post treatment cost \_\_\_\_\_ (specify US\$ or Euro\$)

2. Breakdown of O&M cost

Labor \_\_\_\_\_ (specify US\$ or Euro\$)

Chemicals \_\_\_\_\_ (specify US\$ or Euro\$)

Energy \_\_\_\_\_ (specify US\$ or Euro\$)

Membrane replacement \_\_\_\_\_ (specify US\$ or Euro\$)

Replacement parts (not membranes) \_\_\_\_\_ (specify US\$ or Euro\$)

Concentrate disposal \_\_\_\_\_ (specify US\$ or Euro\$)

Other (please specify) \_\_\_\_\_ (specify US\$ or Euro\$)

3. Current energy cost \_\_\_\_\_ (specify US\$/KWH or Euro\$/KWH)

4. Other (please provide)

\_\_\_\_\_

Post Treatment Stabilization of Desalinated Water  
Post Treatment Questionnaire

Plant Name: \_\_\_\_\_

**VII. LESSONS LEARNED**

Please share with us lessons learned or major issues confronted after your desalting plant was placed into service (the following are provided as example topics).

1. Pilot Testing. Did pilot testing reveal any water quality concerns for distribution system?

\_\_\_\_\_  
\_\_\_\_\_  
\_\_\_\_\_  
\_\_\_\_\_

2. Design. Did design of facility consider impacts of permeate on the distribution system?

\_\_\_\_\_  
\_\_\_\_\_  
\_\_\_\_\_  
\_\_\_\_\_

3. Permitting/regulations. With respect to post-treatment (disinfection), what obstacles were overcome to obtain permits/consents?

\_\_\_\_\_  
\_\_\_\_\_  
\_\_\_\_\_  
\_\_\_\_\_

4. Startup. Did you experience issues in distribution system after plant startup and if so, what did you do to resolve the problem?

\_\_\_\_\_  
\_\_\_\_\_  
\_\_\_\_\_  
\_\_\_\_\_

Post Treatment Stabilization of Desalinated Water  
Post Treatment Questionnaire

Plant Name: \_\_\_\_\_

5. Operations. Are these issues in distribution system that has been directly related back to post treatment?

\_\_\_\_\_  
\_\_\_\_\_  
\_\_\_\_\_  
\_\_\_\_\_

6. Other Additional Comments:

\_\_\_\_\_  
\_\_\_\_\_  
\_\_\_\_\_  
\_\_\_\_\_  
\_\_\_\_\_  
\_\_\_\_\_  
\_\_\_\_\_  
\_\_\_\_\_



## **APPENDIX B: WORKSHOP AGENDA**

# UNIVERSITY OF CENTRAL FLORIDA

College of Engineering and Computer Science  
Civil and Environmental Engineering

## Post-Treatment Stabilization of Desalinated Water

### Expert Workshop

(AwwaRF Project 4079)

### Meeting Agenda

May 21-23, 2008

#### Location

Fairwinds Alumni Center  
University of Central Florida  
4000 Central Florida Blvd  
Orlando, FL 32816

#### On-Site Contacts:

**Steve Duranceau**  
Cell: (407) 492-8197

**Tammy Russo (NWRI)**  
Cell: (714) 614-7386

---

#### Wednesday – May 21, 2008

---

6:00 – 7:30 pm      **Reception**      **Alumni Center Lounge**

---

#### Thursday – May 22, 2008

---

7:30 a.m.	<b>Registration and Continental Breakfast</b>	<b>Ballroom A and B</b>
8:00 a.m.	<b>Welcome and Introductions</b>	Steve Duranceau Chris Rayburn (AwwaRF)
8:15 a.m.	Workshop Orientation	Steve Duranceau Jeff Mosher (NWRI)
8:30 a.m.	Status of Questionnaires	Steve Duranceau
8:45 a.m.	Preliminary Results of Question: "Name the three most important post-treatment topics in your mind?"	Steve Duranceau
9:30 a.m.	NGT: Priority Issue Identification - Round Robin participation	Jeff Mosher
10:45 a.m.	<b>BREAK</b>	
11:00 a.m.	NGT: Issue Consolidation	Jeff Mosher Steve Duranceau
12:00 noon	<b>LUNCH</b>	<b>Ballroom A</b>
1:00 p.m.	NGT: Issue Consolidation (continued)	

3:00 p.m.	<b>BREAK</b>	
3:15 p.m.	NGT: Priority Issue Ranking	Jeff Mosher Steve Duranceau
4:15 p.m.	NGT: Workshop Groups Action Planning (Break out into groups)	All
5:30 p.m.	<b>BREAK</b>	
6:30 p.m.	<b>DINNER</b> - American Grill (Hilton Garden Inn)	

---

**Friday – May 23, 2008**

---

7:30 a.m.	<b>Continental Breakfast</b>	<b>Ballroom A and B</b>
8:00 a.m.	<b>Review of First Day</b>	Steve Duranceau
8:15 a.m.	NGT: Workshop Groups Action Planning (Break out into groups)	All
10:45 a.m.	<b>BREAK</b>	
11:00 a.m.	NGT: Working Group Report Presentations	Group Representatives
12:00 noon	<b>LUNCH</b>	<b>Ballroom A</b>
1:00 p.m.	NGT: Working Group Report Presentations (continued)	Group Representatives
2:30 p.m.	Workshop Summary and Next Steps	Steve Duranceau
3:30 p.m.	<b>Adjourn</b>	

**APPENDIX C: NOMINAL GROUP TECHNIQUE WORKSHOP  
GUIDLINE AND PROCEDURES**

## Nominal Group Technique Workshop

### Guidelines and Procedures

**Workshop question:** “Name the three most important post-treatment topics in your mind?”

The workshop will employ the Nominal Group Technique (NGT) process to ensure that (1) each participant’s time and talents are used effectively, and (2) there are useful results. Please observe the following guidelines:

- ❖ The workshop will begin with a reception at on May 21 and will conclude on the afternoon of May 23.
- ❖ If you have a laptop, please bring it to the workshop for the breakout groups.
- ❖ Come prepared to provide responses to the workshop question.

The workshop will consist of four distinct parts that will require your full attention and participation:

1. **Priority Issue Identification.** Prior to the workshop, each participant provided Steve Duranceau with three Priority Issues in response to the workshop question. Once the workshop begins, each participant will have an opportunity to provide additional Priority Issues. The presenter will provide a title, describe the issue and its importance, and describe how he or she proposes to address this issue. Audience discussion will be limited to questions of clarification. The issue titles will then be posted on the workroom wall.
2. **Consolidation.** After every participant has had the opportunity to present their Priority Issues, the participants will review and discuss each issue posted on the wall. When agreed by consensus, those issues that fit into overarching themes will be consolidated.
3. **Priority Ranking.** Each participant will prioritize his or her top 10 issues on the Priority Issue Ranking Form.
4. **Working Groups.** Participants will be divided into working groups. Each working group will be assigned one or more of the top 10 priority issues. The working groups will then generate a report on that issue, which is to be presented on Friday morning. The workshop will adjourn after each group has presented and signed-off on their reports.

## **APPENDIX D: PRIORITY ISSUE IDENTIFICATION FORM**

## Priority Issue Identification Form

Name: \_\_\_\_\_

**Workshop question:** *“Name the most important post-treatment topics?”*

**Title:** (10 words max)

**Issue Description:** (Describe the issue that is to be met or complied with.)

**Importance:** (Why is this issue important?)

**How Do You Propose Meeting or Complying With This Issue?** (Recommend an approach to complying with this issue. Do you know individuals, or organizations, that would be particularly able to illuminate, refine, and focus this issue?)

## REFERENCES

- Agus, E., N. Vouthkov, and D.L. Sedlak. 2009. "Disinfection By-Products and Their Potential Impact on the Quality of Water Produced by Desalination Systems: A Literature Review." *Desalination*, 237: 214-237.
- Al Arrayedhy, M. 1987. Pre- and Post-treatment at the RO Plant at RA's Abu Jarjur Bahrain. *Desalination*., 63: 81-94.
- AWWA (American Water Works Association). 1992a. *Lead and Copper Rule Guidance Manual, Volume I: Monitoring*. Denver, Colorado: AWWA.
- AWWA (American Water Works Association). 1992b. *Lead and Copper Rule Guidance Manual, Volume II: Corrosion Control Treatment*. Denver, Colorado: AWWA.
- AWWA (American Water Works Association). 2007. *Reverse Osmosis and Nanofiltration Manual of Practice*. Denver, Colorado: AWWA.
- AWWA (American Water Works Association). 1999. *Water Quality and Treatment*. Fifth Edition, McGraw-Hill, New York, New York.
- AWWARF and DVGW-Forschungsstelle. 1985. "Internal Corrosion of Water Distribution Systems." Denver, CO: AWWA Research Foundation.
- Becker, W.C. et. al. 1993. "Complying with the Lead and Copper Rule Effect of Treatment Strategies - A Utility Engineer's Perspective." Proceedings of the Joint CSCE-ASCE National Conference on Environmental Engineering. Montreal, Quebec., 1631-1638.
- Beltran, J.M., and S. Koo-Oshima. 2006. Eds., *Water Desalination for Agricultural Applications* (FAO, Rome, Italy).
- Bergman, Robert A., and Joseph R. Elarde. 2005. Post-treatment of Reverse Osmosis and Nanofiltration Systems for Municipal Water Supply. AWWA Membrane Technology Conference, Phoenix, Arizona.
- Bick, Amos., and Gideon Oron. 2005. "Post-treatment Design of Seawater Reverse Osmosis Plants: Boron Removal Technology Selection For Potable Water Production and Environmental Control." *Desalination*., 178(1-3):233-246.
- Binnie, Chris., Martin Kimber, and George Smethurst. 2002. *Basic Water Treatment*. Heron Quay, London, England. Thomas Telford Publishing.
- Bichsel, Y., and U. Von Gunten. 1999. Oxidation of iodide and hypiodous acid in the disinfection of natural waters. *Environ. Sci. Technol.* 33: 4040-4045.



- Bonnelye, V., M.A. Sanz, L. Francisci, F. Beltran, G. Cremer, R. Colcuera, R and J. Laraudogoitia. 2007. Curacao, Netherlands Antilles: A Successful Example of Boron Removal on a Seawater Desalination Plant. *Desalination.*, 205(1-3): 200-205.
- Burbano, A.A., S.S. Adham, and W.R. Pearce. 2007. The State of Full-Scale RO/NF Desalination – Results from a Worldwide Survey. *AWWA.* 99(4): 116.
- Busch, M., and W.E. Mickols. 2004. Reducing Energy Consumption in Seawater Desalination. *Desalination* 165: 299-312.
- Bush, M., W.E. Mickols, S. Jons, J. Redondo, and J. DeWitte. 2003. *Boron Removal in Seawater Desalination.* Proc. of the International Desalination Association World Congress. Bahrain, Paper BAH03-039.
- Byrne, W. 1995. *Reverse Osmosis: A Practical Guide for Industrial Users.* Littleton, Co., Tall Oaks Publishing.
- Chiodini, R.A., 1998. The Use of Sodium Silicate for the Control of Lead and Copper. *Journal of the New England Water Works Association.* 112:2:147.
- Clesceri, L.S., Arnold E. Greenberg, and Andrew D. Eaton. 1998. Standard Methods for the Examination of Waste and Wastewater 20<sup>th</sup> Edition, United Book Press Inc., Baltimore, Maryland, pp 4-96- 4-97.
- Cohen A., and Meyers J.R. 1987. “Mitigating Copper Pitting Through Water Treatment”, *JAWWA.*
- Delion, N., G. Mauguin and P. Corsin. 2004. Importance and Impact of Post-treatments on Design and Operation of SWRO Plants. *Desalination*, 165: 323-334.
- Delbecq, A.L., and A.H. Van de Ven. 1971. Group Process Model for Problem Identification and Program Planning. *Journal Of Applied Behavioral Science* 7(4):466-491.
- Delbecq, A.L., A.H. Van de Ven, and D.H. Gustafson. 1975. Group Techniques for Program Planners: A Guide to Nominal Group and Delphi Processes. Glenview, IL. Scott Foresman and Company.
- Dolcinar, S., and A.I. Schafer. 2006. “Public Perception of Desalinated Versus Recycle Water In Australia.” *Proceedings of the AWWA Desalination Symposium.* Honolulu, HI (posted online at <http://ro.uow.edu.au/commpapers/138>).
- Duranceau, S.J., J.S. Taylor, and L.A. Mulford. 1992. SOC Removal in a Membrane Softening Process. *Journal AWWA*, 84(1): 68-78.
- Duranceau, S.J. 1993. *Membrane Process Post-treatment.* Supplement to AWWA Seminar Proceedings: 1993 Membrane Technology Conference. Baltimore, MD: AWWA, 1-9.

- Duranceau, S.J., R.K. Anderson, R.D. Teegarden. 1999. Comparison of Mineral Acid Pretreatments for Hydrogen Sulfide Removal in Packed Towers. *AWWA*, 91(5): 85-96.
- Duranceau, S. J. 1999. "Holistic Use of Membrane Processes to Reduce Copper Corrosion and Solve Some Source Water Problems." Proceedings of the American Water Works Association Annual Conference. Chicago, IL.
- Duranceau, S.J. 2001. Membrane Practices for Water Treatment. AWWA Trends in Water Series. Denver, CO: AWWA (2001).
- Duranceau, S.J. 2004a. *You Can't Hide From Hydrogen Sulfide*. Proceedings of the Florida Section AWWA 2004 Annual Conference. Orlando, FL (November 14-18, 2004).
- Duranceau, S.J. 2004b. *Post-treatment Considerations for Blending Permeate into Water in to Water Distribution Systems*. Proceedings of the 2004 AMTA Biennial Conference and Exposition. San Antonio, TX: American Membrane Technology Association: (August 4-August 7, 2004).
- Duranceau, S.J., D. Townley, and G.E.C. Bell. 2004c. *Optimizing Corrosion Control in Water Distribution Systems*. Denver, Co. AWWA Research Foundation.
- Duranceau, S.J., and W.A. Lovins. 2005. *Membrane Post-treatment Optimization for Blending Permeate Into Water Distribution Systems*. Proceedings of the 2005 AWWA Distribution System Symposium Conference and Exposition. Tampa, FL: AWWA (September 18-21).
- Duranceau, S.J. 2006. *Post-treatment and Distribution System Impacts*. Proceedings of the AWWA 2006 Desalination Symposium. Honolulu, HI: (May 7-9, 2006).
- Dykes, G.M., and W.J. Conlon. 1989. Use of Membrane Technology in Florida. *Journal AWWA*. 43: 43-46.
- Fayad, N.M. 1993. Seasonal Variations of THMs in Saudi Arabian Drinking Water. *AWWA*. 85: 46-50.
- Fritzmann, C., J. Lowenberg, T. Wintgens, and T. Merlin. 2007. State-of-the-art Reverse Osmosis. *Desalination.*, 216(1-3): 1-76.
- Global Water Intelligence. 2008. IDA/GWI Worldwide Desalination Plant Inventory. London: Global Water Intelligence.
- GDWQS. 1993. Gulf Drinking Water Quality Standards. GS/149/1993.
- Haag, W.R., and J. Hoigne. 1983. *Environ. Sci. Tech.* 17:3728.
- Harms, L.L., Clement, J.A, and Schock, M.R. 1994. "Water Chemistry of Lead Control", Critical Issues in Water and Wastewater Treatment, Boulder, Colorado.

- Hendricks, David W. 2006. *Water Treatment Unit Processes; Physical and Chemical*. 6000 Broken Sound Parkway NW, Suite 300, Boca Raton, FL. CRC Press, Taylor & Francis.
- Holm, T.R. and Schock, M.R. 1991. "Potential Effects of Polyphosphate Products on Lead Solubility in Plumbing Systems." *Journal AWWA*, 83 (7): 76-82.
- Hua, Guanghui., David A. Reckhow, and Junsung Kim. 2006. Effect of Bromide and Iodide Ions on the Formation and Speciation of Disinfection Byproducts during Chlorination. *Environ. Sci. Technol.*, 40(9): 3050-3056.
- Imran, S.A., J.D Dietz, G, Mutoti, J.S Taylor, A.A Randall and C.D Cooper. 2005. Red Water Release in Drinking Water Distribution Systems. *Journal AWWA*, 97(9): 93 – 100.
- Imran, S.A., J.D. Dietz, G. Mutoti, W. Xiao, J.S. Taylor, A.A. Randall, and V. Desai. 2006. Optimizing Source Water Blends for Corrosion and Residual Control in Distribution Systems. *Journal AWWA*, 98(5):107 – 115.
- Johnson, J., J. Kim, T. Tran, and R. Yorton. 1993. Evaluation of Corrosion Control Alternatives to meet the Lead and Copper Rule for Eastern Massachusetts.
- Johnson, B., R. Yorton, T. Tran, and J. Kim. 1994. "Evaluation of Corrosion Control Alternatives for Low pH, Low Alkalinity Surface Waters in Eastern Massachusetts", *Critical Issues in Water and Wastewater Treatment*, Boulder, Colorado.
- Kedem, O., and A. Katchalsky. 1958. Thermodynamic Analysis of the Permeability of Biological Membranes to Nonelectrolytes. *Biochimica et Biophysica Acta*, 27:123.
- Krasner, S.W., M.J. McGuire, J.G. Jacangelo, N.L. Patania, K.M. Reagan, and E.M. Aieta. The Occurrence of Disinfection By-Products in US Drinking Water." *Jour. AWWA*, 81(8): 41-53
- Krasner, S.W., S.M. Chinn, Z.K. Chowdhury, and D.M. Owen. 1996. In *Disinfection By-Products in Water Treatment: The Chemistry of Their Formation and Control*. Ed. P. Singer. CRC Lewis, Boca Raton, FL pg. 59-60.
- Lahav, Ori. and Liat Birnhack. 2007. Quality Criteria for Desalinated Water Following Post-Treatment. *Desalination.*, 207: 286-303.
- Larosa-Thompson, J.L., B.E Scheetz., M.R Schock., et al. 1997. "Sodium Silicate Corrosion Inhibitors: Issues of Effectiveness and Mechanism." In: *Proceedings American Water Works Association Water Quality Technology Conference*, Denver, CO, November 9–12.
- Lehrman, L., H.L Shuldener. 1951. Role of sodium silicate in inhibiting corrosion by film formation on water piping. *Journal AWWA*. 43(3):175-188.
- Lovins, W.A.; S.J. Duranceau, T. King and S. Medeiros. 2004a. Trumping Hydrogen Sulfide. *Water Environment & Technology*. 16(3): 37-41.

- Lovins, W.A., S.J. Duranceau, R. Powell and J.R. Voorhees. 2004b. Blending Multiple Source Waters in a Common Water Distribution System. Proceedings of the Florida Section AWWA 2004 Annual Conference. Orlando, FL (November 14-18, 2004).
- Lyn, T. L. and Taylor, J.S. 1993. "Turbidity Control Following Hydrogen Sulfide Chlorination." *JAWWA*. 84(1):68-78.
- Lytle, D.A.; Schock, M.R.; & Sorg, T.J. 1996. Controlling Lead Corrosion in the Drinking Water of a Building by Orthophosphate and Silicate Treatment. *Journal of the New England Water Works Association.*, 110:3:202.
- Magara, Y, A. Tabata, M. Kohki, M. Kawasaki and M. Hirose. *Desalination*. 118: 25-34.
- Mallevalle, J., I.H Suffet. 1987 *Identification of taste and odor compounds in the drinking waters*. Denver Colo., USA: American Water Works Association Research Foundation and Lyonnaise des Eaux,
- Mallevalle, J; Odendaal, P.E.; Wiesner, M.R. 1996. *The Emergence of Membranes in Water and Wastewater Treatment in Annular Water Treatment Membrane Processes*, J. Mallevalle et.al., editors. New York. McGraw-Hill.
- McGuire Environmental Consultants Inc. 2004 Final Report- Disinfection byproduct formation in a simulated distribution system: blending desalinated seawater from the Poseidon Resources, Inc. pilot facility with local drinking water sources. McGuire/Malcolm Pirnie, 1919 Santa Monica Blvd. Suite 200, Santa Monica, CA 90404-1955.
- McNeill, Laurie S., Marc Edwards. 2001. Iron Pipe Corrosion in Distribution Systems. *Journal AWWA.*, 93(7):88-100.
- Melnick, L., O. Vysotskaja and B. Kornilovich. 1999. *Desalination*. 124: 125-130.
- Pervov, Alexei G., Alexei P. Andrianov, Roman V Efremov, Andrey V. Desyatov and Alexei E Baranov. 2003. RO Membrane Rejection: A new solution for the Caspian Sea Desalination, Low-Pressure Membranes. *Desalination*, 157(1-3):377-384. European Conference on Desalination and the Environment: Fresh Water for all, Malta, 4–8 May 2003.
- Pinto, J.A.; McAnally, A.S.; & Flora, J.R.V., 1997. Evaluation of Lead and Copper Corrosion Control Techniques. *Journal of Environment Science and Health.*, A32:1:31.
- Pisigan, R.A., Jr. and J.E. Singley. 1984. Evaluation of Water Corrosivity Using the Langelier Index and Relative Corrosion Rate Models." Corrosion/84. Paper 149, National Association of Corrosion Engineers, New Orleans, LA.
- Prats, D., M.F. ChillónArias and R. Pastor. 2003. *Desalination*. 120: 145-152.

- Price, S. and F.T. Jefferson. 1993. *Journal of New England Water Works Association*. 111:285-293.
- Powell, J.H., and M.E. Guild. 1961. Salinity Problems in the Arid Zones: Field Operation of Electric Membrane Equipment for Water Desalination. Proceedings of the Teheran Symposium, UNESCO. 363-370.
- Ramaley, B.L., "Monitoring and Control Experience Under the Lead and Copper Rule." *JAWWA*, February 1993.
- Redondo, J. 2001. Brackish-, Sea- and Wastewater Desalination. *Desalination*, 138(1-3): 29-40.
- Reiber, S., 1989. "Copper Plumbing Surfaces: An Electrochemical Study", *JAWWA*, July, 1989.
- Richardson, S.D.; A.D. Thurston; C. Rav-Acha; L. Groisman, I. Popilevsky, O.Juraev, V. Glezer, A.B. McKague, M.J. Plewa and E.D. Wagner. 2003. *Environ. Sci. Tech.* 37: 3782.
- Rodriguez, M., A.F. Ruiz, M.F. Chilon and D.P. Rico. 2001. *Desalination*. 140: 145-157.
- Rook, J.J. 1977. *Env. Sci. Technology*. 11: 478.
- Rogina, B and M. Dubravcic. 1953. "Micro-determination of iodides by Arresting the Catalytic Reduction of Ceric Ions", *The Analyst*, 78: 594-599.
- Rowe, D.R., and I.M. Abdel-Magid. 1995. *Handbook of Wastewater Reclamation and Reuse*, Boca Raton: CRC Press.
- Ruggieri, F.; J.L. Fernandez-Turiel; D. Gimeno; F. Valero; J.C. Garcia; M.E. Medina. 2008. "Limestone Selection Criteria for EDR Water Remineralization." *Desalination*, 227 :314-326.
- Ryder, R.A.; & Wagner, I. Corrosion Inhibitors. *Internal Corrosion of Water Distribution Systems*. AWWARF/DVGW-Forschungsstelle Coop.Res.Rept. 1985.
- Ryznar, J.W. 1944. "A New Index for Determining the Amount of Calcium Carbonate Scale Formed by a Water." *Journal Amer. Water Works Assoc.* 36: 472.
- Sarin, P., V.L. Snoeyink, D.A. Lytle, and W.M. Kriven. 2004. *Journal of Environmental Engineering*, 130(4): 364-373.
- Schock, M.R. & Wagner, I. The Corrosion and Solubility of Lead in Drinking Water. *Internal Corrosion of Water Distribution Systems*. AWWARF/DVGW-Rorschungsstelle Coop.Res.Rept. 1985.
- Schock, M.R. 1988. "Understanding Corrosion Strategies for Lead", *JAWWA*, July, 1988.
- Schock, M.R. 1990. "Internal Corrosion and Deposition Control," in *Water Quality and Treatment*. New York, NY: McGraw Hill, Inc; 997-1111.

- Schock, M.R. et. al. 1998. "Replacing Polyphosphate with Silicate to Solve Problems with Lead, Copper and Source Water Iron." Proceedings of the AWWA Water Quality Technology Conference. San Diego, CA.
- Schock, M.R.; Lytle, D.A.; Sandvig, A.M.; Clement J.; & Harmon, S.M., 2005. Replacing Polyphosphate with Silicate to Solve Lead, Copper, and Source Water Iron Problems. *Journal AWWA*, 97:11:84
- Singley, J.E. 1981. "The Search for a Corrosion Index." *Jour. AWWA*. 73(10):529.
- Sittig, M. 1985. In: Handbook of Toxic and Hazardous Chemicals and Carcinogens, 2nd Ed., Noyes Data Corporation, Park Ridge, New Jersey, p. 148.
- Suibing Liu, Michael LePuil, J. S. Taylor and A. A. Randall. 2007. "Nanofiltration and reverse osmosis biostability relative to alternative methods of water treatment," in Journal of Water Supply: Research and Technology-AQUA. *Q IWA Publishing*. Issue 56.1
- Taniguchi M, Y. Fusaoka, T. Nishikawa and M. Kurihara. 2004. Boron Removal in RO Seawater Desalination. *Desalination*, 167(1-3):419-426.
- Tang, Z., S. Hong, W. Xiao, and J. Taylor. 2006. Water Research, Volume 40. Pages 943-950.
- Thresh, J.C., The action of natural waters on lead, Parts I and II. *Analyst*, 1922, 47:459-468, 501-505.
- Mallevalle, J. and Suffet, I.H., eds. 1987. The Identification and Treatment of Tastes and Odors in Drinking Water. Denver, CO: American Water Works Association Research Foundation.
- Taylor, J.S., S.J. Duranceau, W.M. Barrett, and J.F. Goigel. 1989. *Assessment of Potable Water Membrane Applications and Research Needs*. Denver, CO: AWWA Research Foundation, December (1989).
- Taylor J. S. and E. P. Jacobs, Reverse Osmosis and Nanofiltration, Water Treatment Membrane Processes, Chapter 9, McGraw-Hill, October 1996, 70 pages.
- Taylor, J., J. Dietz, A. Randall and S. Hong. 2005. *Water Science Technology*. Volume 51, Issue 6-7, Pages 285-291.
- Thompson, J.L.; B.E. Scheetz; M.R. Schock; D.A. Lytle; P.J. Delaney. 2003. Sodium Silicate Corrosion Inhibitors: Issues of Effectiveness and Mechanism. Report 12: Valley Forge, PA: PQ Corporation, P.O. Box 840, Valley Forge, PA 19482.
- Trussell, R. Rhodes & Jerome F. Thomas. 1971. A discussion of the Chemical Character of Water Mixtures. *Journal AWWA*, 63(1):49-51.

- USEPA. 1991. "Lead and Copper Final Rule." Federal Register. 56; 110; 26460.
- USEPA. 1992. Lead and Copper Rule Guidance Manual, Volume II: Corrosion Control Treatment. USEPA 811-B-92-002. Washington, D.C.: Office of Water.
- USEPA. 2003. "Revised Guidance Manual for Selecting Lead and Copper Control Strategies."
- USEPA. 2007. IRIS Database. [www.epa.gov/iris](http://www.epa.gov/iris).
- Wangnick, K. 2004. 2004 IDA Worldwide Desalting Plants Inventory, Rept. 18. Wangnick Consulting, GMBH, Gnarrenburg, Germany. WHO. 2003a. Report of the WHO workshop: Nutrient minerals in drinking water and potential health consequences of long-term consumption of demineralized and remineralized and altered mineral content drinking waters. Rome, November 11-13, 2003 (SDE/WSH/04.01).
- Weber, W.J. 1972. Physiochemical Processes for Water Quality Control. New York: John-Wiley and Sons.
- WHO. 2003b. Emerging Issues in Water and Infectious Disease. Geneva: WHO Press.
- WHO. 2004. WHO Guidelines for Drinking Water Quality. Geneva: WHO Press.
- WHO. 2005. Nutrients in Drinking-water. Water, Sanitation and Health Protection and the Human Environment, Geneva.
- WHO. 2006. Expert Committee Mtg on Health Effects of Calcium and Magnesium in Drinking water. April 27-28 Wash. D.C. Document Production Services, Geneva, Switzerland.
- Withers, Anthony., 2005. Options for Recarbonation, Remineralisation and Disinfection for desalination Plants. *Desalination*., 179 (1-3):11-24.
- Yermiyahu U, Tal A, Ben-Gal A, Bar-Tal A, Tarchitzky J, and Lahav O. 2007. Rethinking desalinated water quality and agriculture. *Science*, Volume 318, Pages 920-921
- Yu Zhao and J. S. Taylor, "Modeling Membrane Performance over Time, JAWWA, 96:12, Dec. 2004.
- Yu Zhao and J. S. Taylor, "Incorporating Osmotic Pressure in an Integrated Incremental Model for Predicting RO or NF Permeate Concentration", *Desal.*, vol.174 no.2 (2005) pp. 145-159.
- Yu Zhao and Taylor, J. S., "Assessment of ASTM D 4516 for Evaluation of Reverse Osmosis Membrane Performance ", *Desalination*, Vol. 180, Issues 1-3, 15 Aug 2005, Pages 231-244
- Yu, Zhao., J. Taylor and S.K. Hong. 2005. "Combined influence of membrane surface properties and

feed water qualities on RO/NF mass transfer, a pilot study". *Water Research*, 39(7): April 2005, Pages 1233-1244.